

US00RE40010E

(19) **United States**
(12) **Reissued Patent**
Kain

(10) **Patent Number: US RE40,010 E**
(45) **Date of Reissued Patent: Jan. 22, 2008**

(54) **JUVENILE VEHICLE SEAT CUP HOLDER**
(75) Inventor: **James M. Kain**, Troy, OH (US)
(73) Assignee: **Cosco Management, Inc.**, Wilmington, DE (US)
(21) Appl. No.: **10/702,055**
(22) Filed: **Nov. 6, 2003**

4,754,999 A	7/1988	Kain
4,759,584 A	7/1988	Dykstra et al.
4,799,731 A	1/1989	Brown
4,818,017 A	4/1989	Dykstra et al.
4,828,211 A	5/1989	McConnell et al.
4,927,200 A	5/1990	Wilkins
4,942,827 A	7/1990	Norgaard
4,943,111 A	7/1990	VanderLaan
4,951,997 A	8/1990	Kenney
5,007,610 A	4/1991	Christiansen et al.
5,035,464 A	7/1991	Spallholtz
5,072,909 A	12/1991	Huang
5,131,716 A	7/1992	Kwasnik et al.
5,150,946 A	9/1992	Marfilius et al.
5,248,183 A	9/1993	Gignac
5,286,084 A	2/1994	Bart
5,289,962 A	3/1994	Tull et al.
5,332,286 A	7/1994	Atherton et al.
5,494,249 A	2/1996	Ozark et al.
5,524,957 A	6/1996	Gibriano
5,567,008 A	10/1996	Cone, II
5,586,806 A	12/1996	Hergott
5,615,925 A	4/1997	Kain
5,618,018 A	4/1997	Baniak

Related U.S. Patent Documents

Reissue of:

(64) Patent No.: **6,612,649**
Issued: **Sep. 2, 2003**
Appl. No.: **10/377,653**
Filed: **Mar. 4, 2003**

U.S. Applications:

(63) Continuation of application No. 09/881,503, filed on Jun. 14, 2001, now Pat. No. 6,550,862.

(51) **Int. Cl.**
A47C 1/08 (2006.01)

(Continued)

(52) **U.S. Cl.** **297/250.1**; 297/188.11;
297/188.21; 297/256.16

(58) **Field of Classification Search** 297/250.1,
297/188.11, 188.01, 188.21, 252, 256.16;
224/275

See application file for complete search history.

OTHER PUBLICATIONS

“Memorandum in Support of the Motion of Defendant GRACO Children’s Products, Inc. for Summary Judgment of Non Infringement”, filed Jan. 5, 2004 in the U.S. District Court for the Southern District of Indiana, *Dorel Juvenile Group, Inc. vs. Graco Children’s Products, Inc.*

(Continued)

(56) **References Cited**

U.S. PATENT DOCUMENTS

2,635,680 A	4/1953	Zentmire
3,637,184 A	1/1972	O’Brien
4,345,791 A	8/1982	Bryans
4,434,961 A	3/1984	Hoye
4,527,830 A	7/1985	Meyers
4,634,177 A	1/1987	Meeker
4,715,652 A	12/1987	Ward
4,729,600 A *	3/1988	Single et al. 297/256.13
4,733,908 A	3/1988	Dykstra et al.
4,733,909 A	3/1988	Single, II

Primary Examiner—Milton Nelson, Jr.
(74) *Attorney, Agent, or Firm*—Barnes & Thornburg LLP

(57) **ABSTRACT**

A juvenile vehicle seat is provided including a cup holder. The cup holder is movable between a retracted position adjacent the seat and an extended position spaced from the seat.

17 Claims, 3 Drawing Sheets

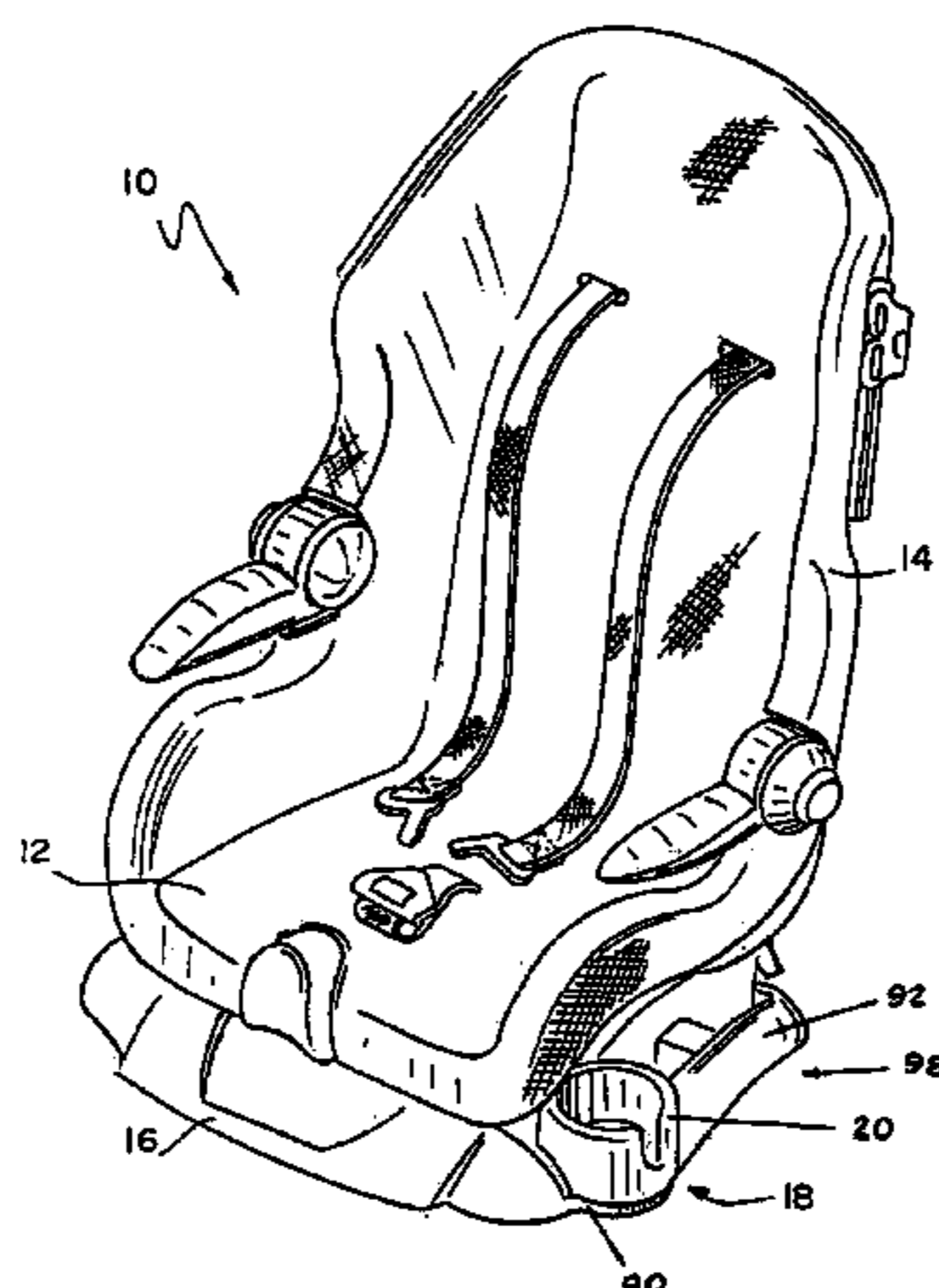

U.S. PATENT DOCUMENTS

5,628,486	A	5/1997	Rossman et al.
5,685,604	A	11/1997	Kain
5,746,363	A	5/1998	Teller et al.
5,788,324	A	8/1998	Shea et al.
5,947,554	A	9/1999	Mashkevich
5,964,502	A	10/1999	Stephens
6,019,334	A	2/2000	Shinomiya
6,065,729	A	5/2000	Anderson
6,105,917	A	8/2000	Yabuya et al.
6,142,574	A	11/2000	Alexander
6,220,660	B1	4/2001	Bedro et al.
6,250,527	B1	6/2001	Mizue et al.
6,253,975	B1	7/2001	Ichioka et al.
6,264,273	B1	7/2001	Waters, Sr.
6,343,837	B1	2/2002	Gage
6,428,099	B1	8/2002	Kain
6,550,862	B2	4/2003	Kain
6,554,358	B2	4/2003	Kain

OTHER PUBLICATIONS

“Plaintiff’s Memorandum in Support of its (1) *Cross-Motion for Summary Judgment of Infringemen* and (2) *Response in Opposition to Graco’s Motion for Summary Judgment of Noninfringement*”, filed in U.S. District Court for the Southern District of Indiana, *Dorel Juvenile Group, Inc., vs. Graco Children’s Products, Inc.*, Case No. 1:03-CV-1273 LJM-WTL.

Order on Cross Motions for Summary Judgment (Sep. 9, 2004), *Dorel Juvenile Group, Inc.v. Graco Children’s Prods., Inc.*, Case No. 1:03-cv-1273-LJM-WTL.

Entry of Judgment (Sep. 9, 2004), *Dorel Juvenile Group, Inc.v. Graco Children’s Prods., Inc.*, Case No. 1:03-cv-1273-LJM-WTL.

Reply Brief of Plaintiff-Appellant, Dorel Juvenile Group, Inc.(Feb. 18, 2005), *Dorel Juvenile Group, Inc.v. Graco Children’s Prods., Inc.*, Case No. 1:03-cv-1273-LJM-WTL.

Brief of Plaintiff-Appellant, Dorel Juvenile Group, Inc. (Dec. 15, 2004), *Dorel Juvenile Group, Inc.v. Graco Children’s Prods., Inc.*, Case No. 1:03-cv-1273-LJM-WTL.

Brief of Appellee Graco Children’s Products, Inc. (Jan. 26, 2005), *Dorel Juvenile Group, Inc.v. Graco Children’s Prods., Inc.*, Case No. 1:03-cv-1273-LJM-WTL.

Nonconfidential Joint Appendix, (Feb. 28, 2005), *Dorel Juvenile Group, Inc.v. Graco Children’s Prods., Inc.*, Case No. 1:03-cv-12730LJM-WTL.

* cited by examiner

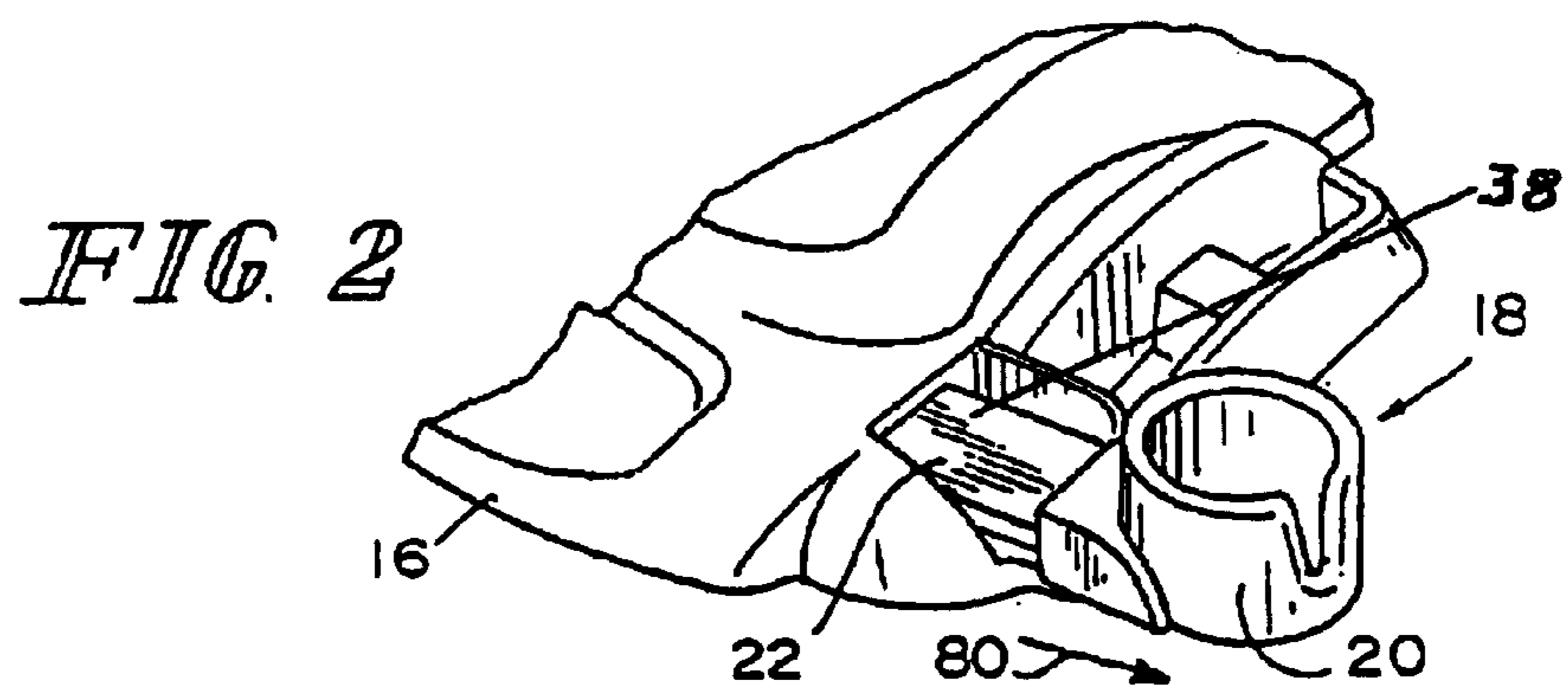
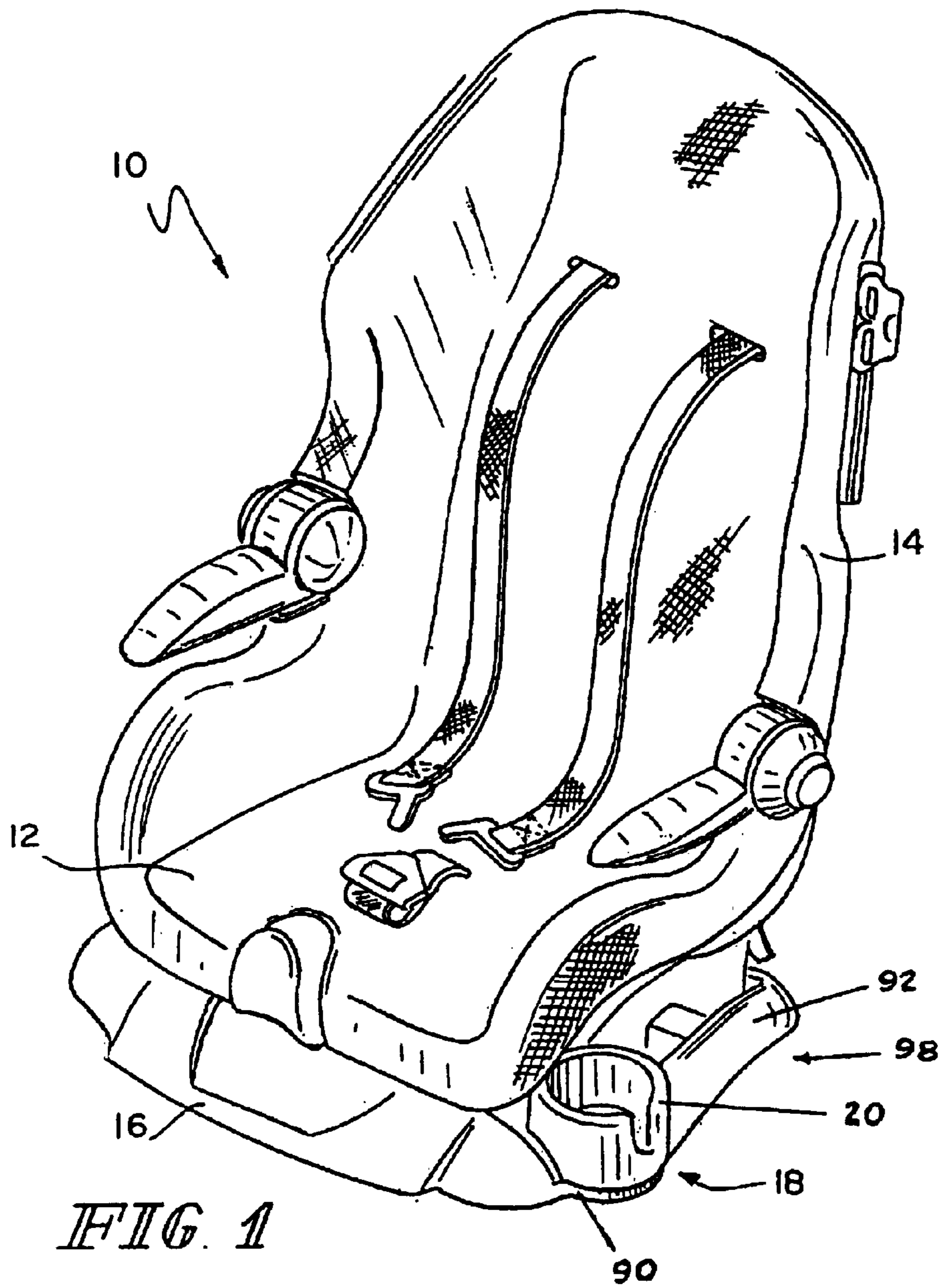

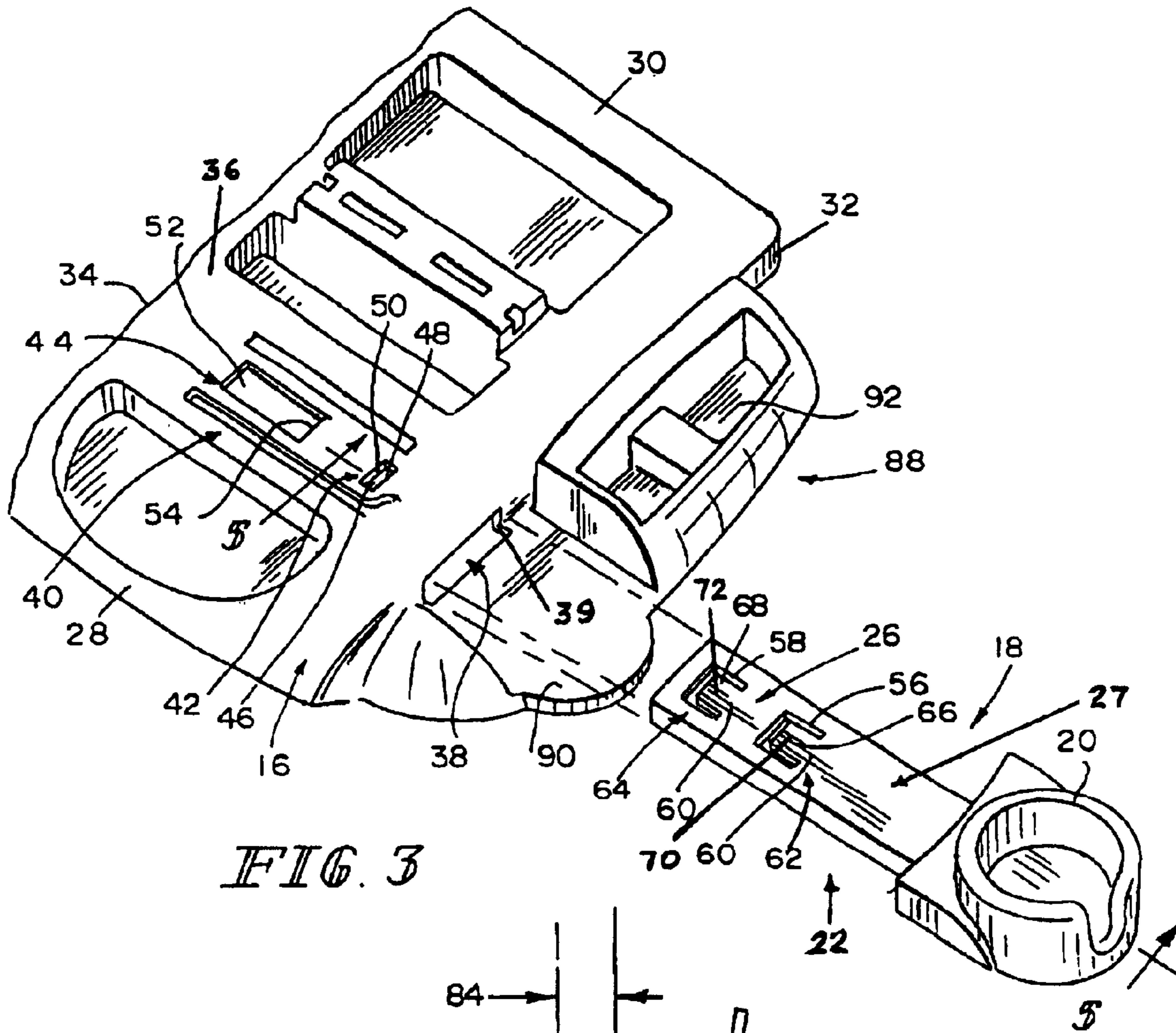

FIG. 3

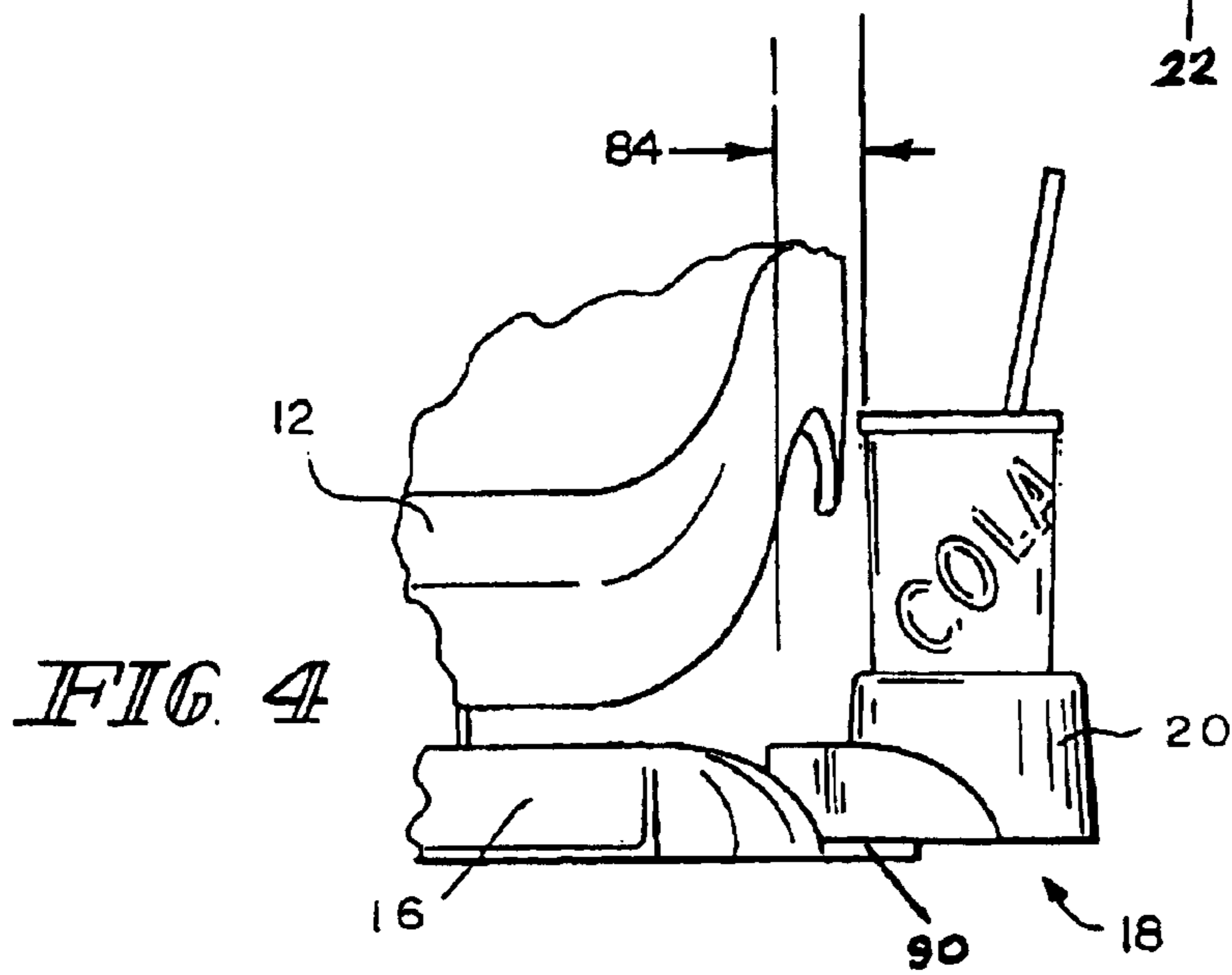
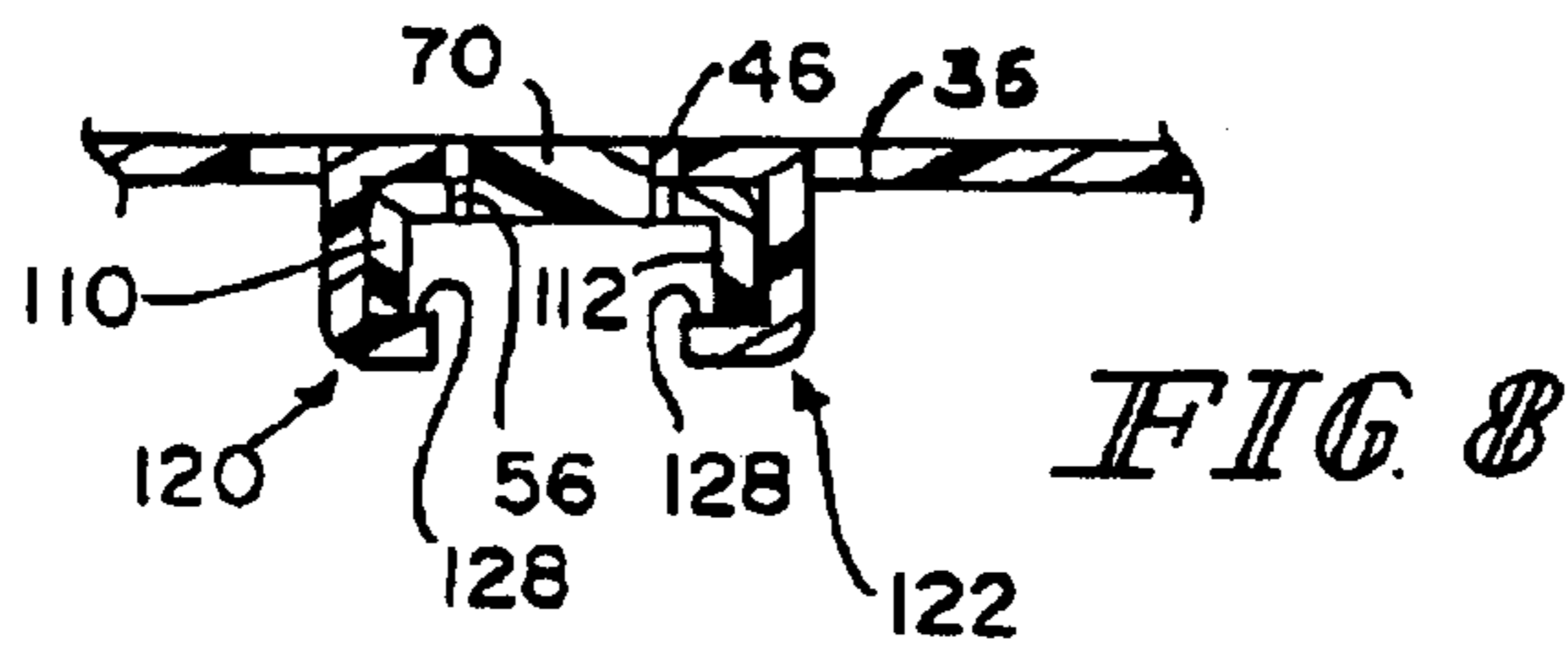
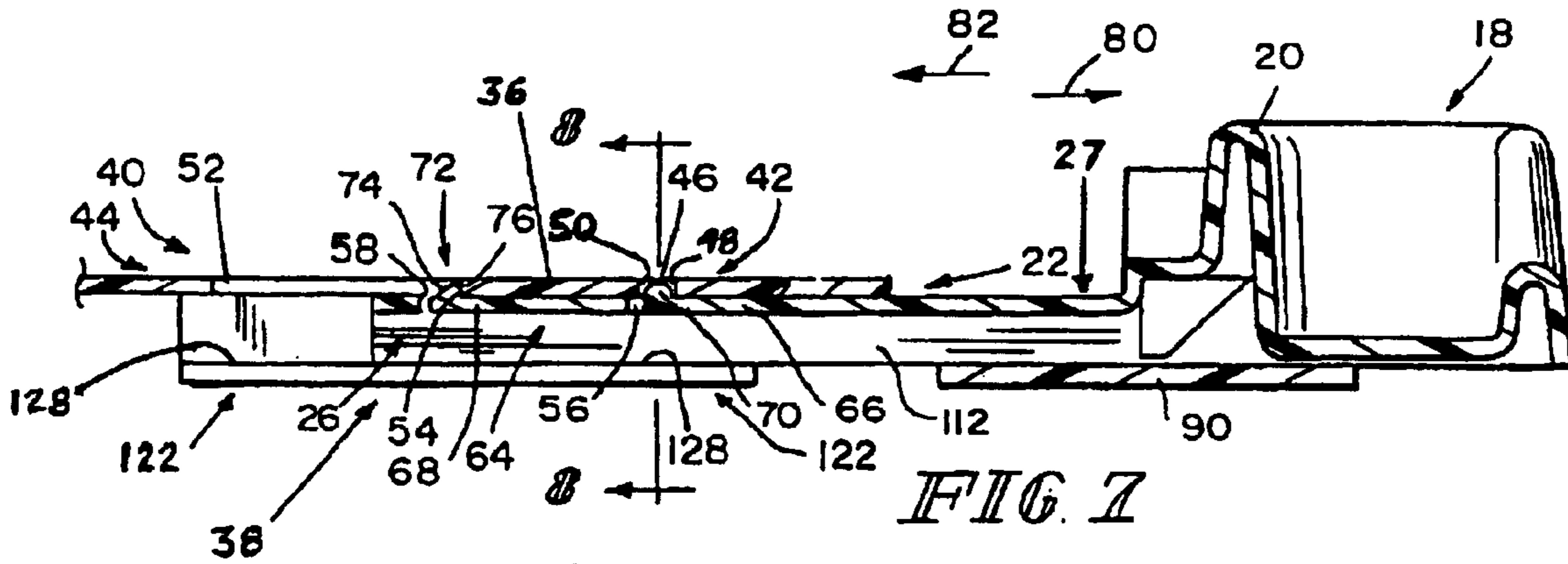
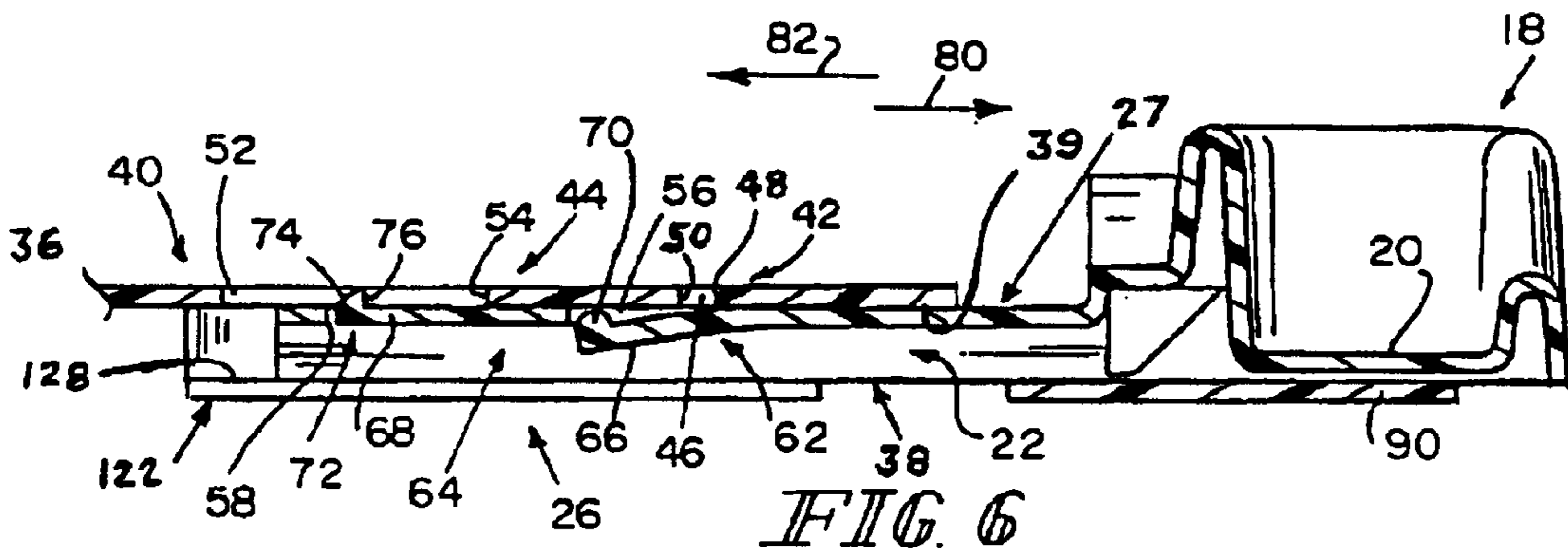
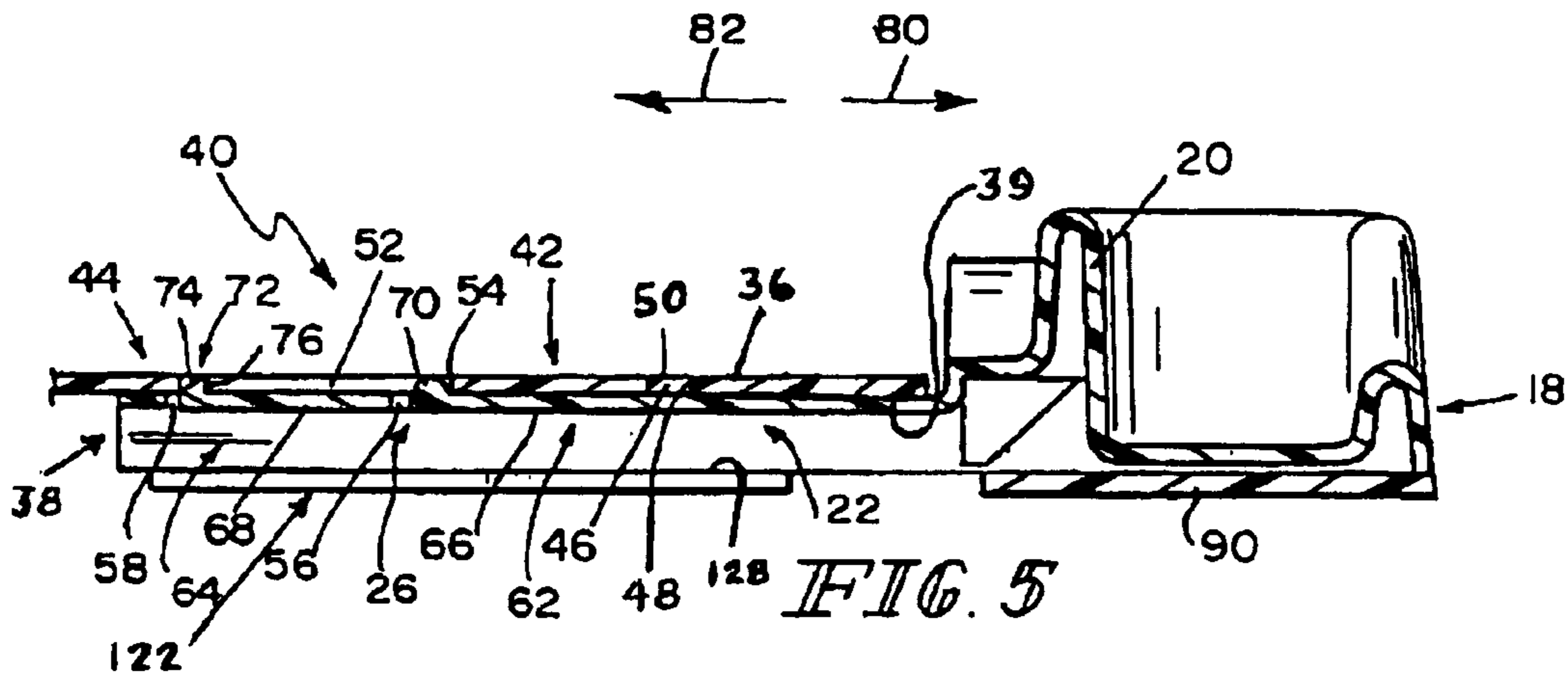

FIG. 4



JUVENILE VEHICLE SEAT CUP HOLDER

Matter enclosed in heavy brackets [] appears in the original patent but forms no part of this reissue specification; matter printed in italics indicates the additions made by reissue.

CROSS-REFERENCE TO RELATED APPLICATIONS

This application is a reissue of U.S. application Ser. No. 10/377,653 filed Mar. 4, 2003, now U.S. Pat. No. 6,612,649, which is a continuation of U.S. application Ser. No. 09/881,503 filed Jun. 14, 2001, now U.S. Pat. No. 6,550,862.

BACKGROUND AND [SUMMEAY] +i SUMMARY

The present application relates to a juvenile vehicle seat and particularly to a juvenile vehicle seat having a cup holder movable between a retracted position and an extended position.

Conventional juvenile vehicle seats are generally known and are in relatively widespread use. It is desirable to provide a juvenile vehicle seat including a cup holder movable between a retracted position and an extended position.

According to the present disclosure, a juvenile vehicle seat is provided including a seat bottom and a seat back and a cup holder movable relative to the seat bottom. The cup holder is movable between a retracted position adjacent the seat bottom and an extended position spaced from the seat bottom.

In an illustrative embodiment, the cup holder includes a cup retainer or article receiver coupled to a connector or connecting member. A first portion of the connector cooperates with a second portion of the seat bottom or a base for the seat bottom to inhibit movement of the cup holder from at least one of the retracted and extended positions.

In another illustrative embodiment, the juvenile vehicle seat base is configured to releasably couple to the seat bottom. The base provides a receptor or aperture to receive the connector. The base includes engagement edges that cooperate with the connector to inhibit movement of the cup holder from at least one of the retracted and extended positions.

In another illustrative embodiment, the connector provides surfaces to engage the engagement edges of the base. One or more flexible tabs provide the surfaces so that when a user applies sufficient force to move the cup holder toward the extended position or the retracted position the tabs flex to disengage the surfaces from the edges. The tabs and surfaces thereon are configured to cooperate with the base or seat bottom to inhibit movement of the cup holder until a deliberate and sufficient force is applied to move the cup holder.

In still another illustrative embodiment, while in the retracted position, the cup holder is spaced apart from the seat bottom by a first distance. In the extended position the cup holder is spaced apart from the seat bottom by a second distance. The second distance is greater than the first distance. The second distance is sufficient so that the cup holder, when in the extended position, can accommodate cups or other articles having dimensions that would not be accommodated by the cup holder in the retracted position.

Additional objects, features, and advantages of the present application will become apparent to those of ordinary skill

in the art upon consideration of the following detailed description of preferred embodiments exemplifying the best mode of carrying out the subject matter of this application as presently perceived.

BRIEF DESCRIPTION OF THE DRAWINGS

The detailed description particularly refers to the accompanying figures in which:

FIG. 1 is a perspective view of a juvenile vehicle seat having a seat back, a seat bottom coupled to the seat back, a base coupled to the seat bottom, and a movable cup holder engaging the base;

FIG. 2 is a perspective view of a portion of the juvenile vehicle seat of FIG. 1 showing the cup holder in an extended position;

FIG. 3 is a perspective view of a portion of the juvenile vehicle seat of FIG. 1 showing the cup holder positioned for assembly;

FIG. 4 is a front view of a portion of the juvenile vehicle seat of FIG. 1 showing the cup holder in the extended position;

FIG. 5 is a sectional view of the juvenile vehicle seat of FIG. 1 taken along line 5—5 of FIG. 3 showing the cup holder in a retracted position, showing the connector engaging the base;

FIG. 6 is a sectional view of the juvenile vehicle seat similar to FIG. 5 showing the cup holder in a position between the retracted and extended positions;

FIG. 7 is a sectional view similar to FIG. 5 showing the cup holder in the extended position; and

FIG. 8 is a sectional view of a portion of the juvenile vehicle seat of FIG. 1 taken along line 8—8 of FIG. 7.

DETAILED DESCRIPTION OF THE [PEEFERRED] PREFERRED EMBODIMENTS

Juvenile vehicle seat assembly 10 includes a seat 12, 14, a base 16, and a cupholder 18 as shown in FIG. 1. Base 16 is arranged to support seat 12, 14 and formed to include a cupholder receptor 38 and first, second, and third engagement surfaces 48, 50, 54 as shown in FIGS. 2 and 3. First, second, and third engagement surfaces 48, 50, 54 are arranged to lie in spaced-apart parallel relation to one another as shown in FIG. 3. Second engagement surface 50 is positioned to lie between the first and third engagement surfaces 48, 54 as shown in FIG. 5.

Cupholder 18 is mounted for movement relative to base 16 between a retracted position shown in FIG. 5 and an extended position shown in FIG. 7. Cupholder 18 includes a cup receiver 20 and a base connector 22 coupled to cup receiver 20 and arranged to extend into cupholder receptor 38 formed in base 16 as suggested in FIGS. 1–3. Base connector 22 including a first retainer 62 arranged to confront first and second engagement surfaces 48, 50 upon movement of cupholder 18 to the extended position to inhibit movement of cupholder 18 relative to base 16 and away from the extended position as shown in FIG. 7. First retainer 62 is also arranged to confront third engagement surface 54 upon movement of cupholder 18 to the retracted position to inhibit movement of cupholder 18 relative to base 16 and toward the extended position.

As shown in FIG. 3, base 16 includes a front 28, a rear 30, and a pair of side walls 32, 34. Base 16 further includes means (not shown) for coupling seat bottom 12 to the base. Side wall 32 of base 16 is formed to include an opening 39

into a cupholder receptor **38** formed in base **16** to receive base connector **22** of cup holder **18** and permit sliding movement of base connector **22** relative to base **16**. Although certain embodiments are disclosed herein as including base **16**, it is within the scope of this disclosure to incorporate the features described herein as being part of base **16** into the seat bottom **12** or other portion of juvenile vehicle seat **10**.

Base **16** includes a deck **36** formed to include first, second, and third engagement surfaces **48**, **50**, **54** and to define a ceiling of cupholder receptor **38** as shown in FIGS. **5-7**. Base connector **22** includes a retainer mount portion **26** that is arranged to lie under deck **36** and a neck portion **27** that is arranged to interconnect retainer mount portion **26** and the cup receiver **20** as shown in FIGS. **3** and **6**. Retainer means **62**, **64** is coupled to base connector **22** for contacting base **16** to inhibit movement of cupholder **18** relative to base **16** between the retracted position and extended position as suggested in FIGS. **5-7**. Retainer means **62**, **64** includes first retainer **62** and second retainer **64** as shown in FIG. **3**.

First retainer **62** is coupled to retainer mount portion **26** as shown in FIG. **3**. First retainer **62** is arranged to extend upwardly toward deck **36** to confront first and second engagement surfaces **48**, **50** upon movement of cupholder **18** to the extended position and to confront third engagement surface **54** upon movement of cupholder **18** to the retracted position.

Deck **36** is formed to include a first opening **46** defined in part by first and second engagement surfaces **48**, **50** and sized to receive therein a portion **70**, e.g. a detent, of first retainer **62** upon movement of cupholder **18** to the extended position. Deck **36** is also formed to include a second opening **52** defined in part by third engagement surface **54** and sized to receive therein the detent **70** of the first retainer **62** upon movement of cupholder **18** to the retracted position as shown in FIG. **5**. Detent **70** has a curved surface arranged to confront first and second engagement surfaces **48**, **50** upon movement of cupholder **18** to the extended position and to confront third engagement surface **54** upon movement of cupholder **18** to the retracted position.

First retainer **62** includes a flexible first tab **66** cantilevered to retainer mount portion **26** of base connector **22** to move up and down relative to deck **36** and detent **70** is appended to flexible first tab **66** to move up and down therewith. Detent **70** is sized to extend into first opening **46** to confront first and second engagement surfaces **48**, **50** upon movement of cupholder **18** to the extended position and to extend into second opening **52** to confront third engagement surface **54** upon movement of cupholder **18** to the retracted position. Flexible first tab **66** provides means for moving detent **70** in an upward direction into second opening **52** to confront third engagement surface **54** upon movement of cupholder **18** to the retracted position as suggested in FIGS. **5** and **6**.

Base connector **22** further includes a second retainer **64** arranged to confront third engagement surface **54** upon movement of cupholder **18** to the extended position to inhibit further movement of cupholder **18** relative to base **16** away from the retracted position so as to block movement of cupholder **18** to a withdrawn position outside of cupholder receptor **38** formed in base **16**. Second retainer **64** is coupled to retainer mount portion **26** to cause first retainer **62** to lie between neck portion **27** and second retainer **64**. Second retainer **64** is arranged to extend upwardly toward deck **36** to confront third engagement surface **54** upon movement of cupholder **18** to the extended position as shown in FIG. **7**

and to lie in spaced-apart relation to third engagement surface **54** upon movement of cupholder **18** to the retracted position as shown in FIG. **5**.

Second retainer **64** includes a flexible second tab **68** cantilevered to retainer mount portion **26** of the base connector **22** to move up and down relative to deck **36** and a catch **72** appended to flexible second tab **68** to move up and down therewith. Catch **72** is sized to extend into the second opening **52** to confront third engagement surface **54** upon movement of cupholder **18** to the extended position.

Catch **72** has a vertical stop surface **76** arranged to contact third engagement surface **54** to inhibit removal of cupholder **18** from cupholder receptor **38** formed in base **16**. Catch **72** also includes a sloped surface **74** arranged to cam on second engagement surface **50** to bend flexible second tab **68** downwardly to move catch **72** relative to deck **36** and away from second engagement surface **50** during initial insertion of base connector **22** into cupholder receptor **38** and movement of cupholder **18** relative to base **16** toward the retracted position. Catch **72** is positioned to lie in spaced-apart relation to third engagement surface **54** upon movement of cupholder **18** to the retracted position.

Base **16** further includes a platform **90** located under a portion of the cupholder **18** and a side wall **32** is located between deck **36** and platform **90**. Side wall **32** is formed to include side opening **39** and cooperate with deck **36** to form cupholder receptor **38** under deck **36** to receive base connector **22** through the side opening **39** as suggested in FIG. **3**. Cupholder **18** is arranged to move along a path above platform **90** during movement of cupholder **18** between the retracted and extended positions as shown in FIGS. **5-7**.

Base **16** further includes left and right guide supports **120**, **122** located in cupholder receptor **38** under deck **36** and arranged to support a portion of cupholder **18** for sliding movement relative to base **16** during movement of cupholder **18** between the retracted and extended positions. Platform **90** is arranged to lie outside of cupholder receptor **38** formed in base **16** to support another portion of cupholder **18** for sliding movement relative to base **16** during movement of cupholder **18** between the retracted and extended positions.

Referring now to FIGS. **4-7**, first portion **26** of base connector **22** is configured to cooperate with a second portion **40** of base **16**. Second portion **40** includes first and second retainer engaging portions **42**, **44** for engaging base connector **22**. Illustratively, first retainer engaging portion **42** provides a first opening or notch **46** providing engagement edges or surfaces **48**, **50** that cooperate with base connector **22** to inhibit movement of cup holder **18** from the extended position. Second retainer engaging portion **44** provides a second opening **52** providing a third engagement edge or surface **54** to cooperate with base connector **22** to inhibit movement of cup holder **18** from the retracted position and to inhibit removal of cup holder **18** from base **16**. Although in illustrative embodiments base **16** includes first and second retainer engaging portions **42**, **44**, a single retainer engaging portion inhibiting movement of the cup holder **18** is within the scope of this disclosure. Additionally, although retainer engaging portions **42**, **44** have been illustrated as including first and second openings **46**, **52** providing engagement edges **48**, **50**, **54**, other known structures cooperating with base connector **22** to inhibit movement of cup holder **18** are within the scope of this disclosure. For example, cup holder **18** could include a structure to interact with the seat bottom or base to provide friction or other form of contact to inhibit movement of the cup holder.

5

As shown in FIG. 3, base connector 22 provides first and second openings 56, 58 each providing a connection edge 60. First portion 26 of base connector 22 includes first and second retainers 62, 64 having first and second tabs 66, 68 respectively, each tab being cantilevered to one of connection edges 60. As shown in FIGS. 5-7, first tab 66 provides a detent 70. Illustratively, detent 70 has a curved surface. Also as shown in FIGS. 5-7, second tab 68 provides a catch 72 having a sloped surface 74 and a stop surface 76.

As shown in FIG. 4, when cup holder 18 is in the extended position, cup receiver 20 is spaced apart from base 16 and seat bottom 12 by a distance 84 greater than when cup holder 18 is in the retracted position. In an illustrative embodiment, distance 84 is about two inches. However, it is within the scope of this disclosure for distance 84 to be other lengths. Distance 84 is illustratively sufficient in length so that cup receiver 20, when in the extended position, can accommodate cups or other articles having dimensions that would not be accommodated by the cup holder 18 in the retracted position.

In the retracted position shown in FIG. 5, cup receiver 20 is proximate or adjacent side 32 of base 16. In this position, catch 72 and detent 70 are positioned in second opening 52. When a user applies force to cup holder 18 in a direction 80, detent 70 engages third engagement edge 54 of opening 52 to inhibit movement of cup holder 18 from the retracted position toward the extended position.

Referring to FIG. 6, as a user applies a force sufficient to move cup holder 18 in direction 80 from the retracted position toward the extended position, the curved surface of detent 70 moves against third engagement edge 54 until first tab 66 fixes and detent 70 disengages third engagement edge 54. As a user continues to slide cup holder 18 in direction 80, detent 70 moves against a bottom surface of second retainer engaging portion 44.

As a user moves cup holder 18 to the extended position shown in FIG. 7, detent 70 snaps into first opening or notch 46. In this position, detent 70 is adjacent edges 48, 50 of first opening 46. Also as shown in the extended position of FIG. 7, catch 72 is adjacent third engagement edge 54 of second opening 52. When cup holder 18 is in the extended position, as a user applies force in direction 80 to cup holder 18, detent 70 and stop surface 76 engage edge 48 and third engagement edge 54 respectively, inhibiting removal of cup holder 18 from base 16. As a user applies force in direction 82 to cup holder 18, detent 70 engages edge 50, inhibiting movement of cup holder 18 from the extended position toward the retracted position.

To insert cup holder 18 into base 16, a user inserts base connector 22 into cupholder receptor 38. As the user moves cup holder 18 toward the retracted position, catch 72 slides along an underside of base 16. Sloped surface 74 facilitates insertion of base connector 22 by the user by reducing resistance in sliding catch 72 past edge 50.

Base 16 includes left and right guide supports 120, 122. Each of guide supports 120, 122 includes a generally upwardly facing support surface 128. In operation, as shown in FIGS. 5-7, guides 110, 112 slide on support surface 128 thereby maintaining first portion 26 of cup holder 18 in the proper position to engage second portion 40 of base 16.

As shown in FIGS. 5-7, platform 90 illustratively provides additional support to cup holder 18 by supporting cup retainer 20 when cup holder 18 is in the retracted position, and by supporting at least a portion of cup receiver 20 or base connector 22 when cup holder 18 is between the retracted and extended positions. When cup holder 18 is in

6

the extended position, platform 90 supports base connector 22. Platform 90 and container 92 are illustratively shaped so that the outer surface contours of cup holder 18 appear to continue the contours of the outer surfaces of platform 90 and container 92. These shapes provide the appearance that the cupholder 18 is an integral part of the base 16 when the cup holder 18 is in the retracted position.

Although this application has described detail with reference to certain preferred or illustrative embodiments, variations and modifications exist within the scope and spirit of the invention as described and defined in the following claims.

What is claimed is:

1. A juvenile vehicle seat assembly comprising
 - a seat,
 - a base removably attached and arranged to support the seat,
 - a cupholder mounted for movement relative to the base between a retracted position and an extended position,
 - a first element on the base,
 - a second element on the cupholder, *and*
 - the first and second elements releasably locking the cupholder in a retracted position and yielding to allow the cupholder to travel and extended position wherein it is releasably held by the first and second elements.
2. The assembly of claim 1, wherein at least one of the first and second elements includes an opening with an engagement surface and the other of the first and second elements includes a catch with a first portion adapted to engage the engagement surface to prevent movement of the cup holder beyond at least one of the retracted and extended positions.
3. The assembly of claim 2, wherein the catch further includes a second portion which is sloped to facilitate movement of the cup holder to the retracted position.
4. The assembly of claim 3, wherein the catch is coupled to a cantilevered tab.
5. The assembly of claim 1, wherein at least one of the first and second elements includes a detent having a first portion adapted to confront an engagement surface on the other of the first and second elements upon movement of the cupholder to the extended position.
6. The assembly of claim 5, wherein the detent has a second portion adapted to confront an engagement surface on the other of the first and second elements upon movement of the cupholder to the retracted position.
7. The assembly of claim 6, wherein the detent is coupled to a cantilevered tab.
8. A juvenile vehicle seat assembly comprising
 - a seat,
 - a base removably attached and arranged to support the seat,
 - a cupholder mounted for movement relative to the seat between a first position and a second position,
 - first and second elements connected to the base and cupholder, respectively,
 - wherein the first and second elements are adapted to releasably lock the cupholder in the first position and to yield allowing the cupholder to travel to the second position wherein it is releasably held by the first and second elements.
9. The assembly of claim 8, wherein at least one of the first and second elements includes a catch
- the other of the first and second elements includes an opening with engagement surfaces

7

wherein at least one of the first and second elements includes a detent having

a first portion adapted to confront an engagement surface on the other of the first and second elements upon movement of the cupholder to the first position and

a second portion adapted to confront an engagement surface on the other of the first and second elements upon movement of the cupholder to the second position.

10 **10.** The assembly of claim **9**, wherein the other of the first and second elements includes a plurality of openings and engagement surfaces.

11. The assembly of claim **8**, wherein at least one of the first and second elements includes a first detent portion adapted to confront an engagement surface on the other of the first and second elements upon movement of the cupholder to the first position and a second detent portion adapted to confront an engagement surface on the other of the first and second elements upon movement of the cupholder to the second position.

12. The juvenile vehicle seat of claim **11**, wherein the cupholder includes a connecting member, the connecting member being movable relative to the base, and a cup receiver coupled to the connecting member to move therewith.

8

13. The juvenile vehicle seat of claim **12**, wherein the cupholder is slidably mounted relative to the base.

14. A juvenile vehicle seat assembly comprising

a seat,

a base removably attached and arranged to support the seat,

a cupholder adapted for movement between a retracted position and an extended position, and

means for releasably locking the cupholder relative to the base in the retracted position and the extended position.

15. The assembly of claim **14** comprising

a first element on the base,

a second element on the cupholder, wherein

the means for releasably locking the cupholder includes the first and second elements.

16. The juvenile vehicle seat assembly of claim 1, wherein the positions of the cupholder mounted for movement relative to the base between the retracted position and the extended position define the limits of movement of the cupholder and the cupholder is usable in both the retracted position and the extended position.

17. The juvenile vehicle seat assembly of claim 1, wherein the seat includes a back.

* * * * *