



US00RE39905E

(19) **United States**
(12) **Reissued Patent**
Mobley

(10) **Patent Number:** **US RE39,905 E**
(45) **Date of Reissued Patent:** **Nov. 6, 2007**

(54) **AIR FRESHENER CARD, METHOD OF USE AND METHOD OF MANUFACTURE**

(76) Inventor: **David Mobley**, 7925 Kristina La., Ft. Worth, TX (US) 76180

(21) Appl. No.: **10/161,593**

(22) Filed: **Jun. 5, 2002**

Related U.S. Patent Documents

Reissue of:

(64) Patent No.: **6,168,088**
Issued: **Jan. 2, 2001**
Appl. No.: **09/326,622**
Filed: **Jun. 7, 1999**

(51) **Int. Cl.**
A61L 9/04 (2006.01)
A24F 25/00 (2006.01)

(52) **U.S. Cl.** 239/6; 239/34; 239/53; 239/54; 422/5; 428/905; 512/1; 512/2; 512/3

(58) **Field of Classification Search** 239/6, 239/34, 53, 54, 56, 55, 289; 422/5, 124, 305; 512/1-4; 428/34.2, 905, 900; 206/0.5
See application file for complete search history.

(56) **References Cited**

U.S. PATENT DOCUMENTS

2,120,204 A * 6/1938 Langhorst 239/54
2,303,073 A * 11/1942 Brown 239/53

3,575,345 A * 4/1971 Buck, Jr. 239/34
4,314,299 A * 2/1982 Ishida et al. 360/130.33
4,802,626 A * 2/1989 Forbes et al. 239/36
4,809,912 A * 3/1989 Santini 239/57
4,889,755 A * 12/1989 Charbonneau 239/34
4,952,400 A * 8/1990 Tararuj et al. 428/905
5,372,303 A * 12/1994 Paul 239/56
5,395,047 A * 3/1995 Pendergrass, Jr. 239/56
5,419,879 A * 5/1995 Vlahakis et al. 422/305
5,497,942 A * 3/1996 Zingle et al. 239/6
5,503,332 A * 4/1996 Glenn 239/56
5,518,790 A * 5/1996 Huber et al. 428/905
5,585,343 A * 12/1996 McGee et al. 512/2
5,611,486 A * 3/1997 Paul 239/56
5,782,409 A * 7/1998 Paul 239/56
5,804,299 A * 9/1998 Nakata et al. 428/334
5,876,678 A * 3/1999 Harrell et al. 239/53
6,012,643 A * 1/2000 Barlow et al. 239/6

* cited by examiner

Primary Examiner—Steven J. Ganey

(74) *Attorney, Agent, or Firm*—Dan Brown Law Office; Daniel R. Brown

(57) **ABSTRACT**

A method for applying air freshener within an automobile is disclosed. The method includes the steps of retrieving an air freshener card, locating a substantially hidden position within the automobile, and placing the air freshener card at the substantially hidden position. An air freshener card and method for making the same is also disclosed.

14 Claims, 1 Drawing Sheet

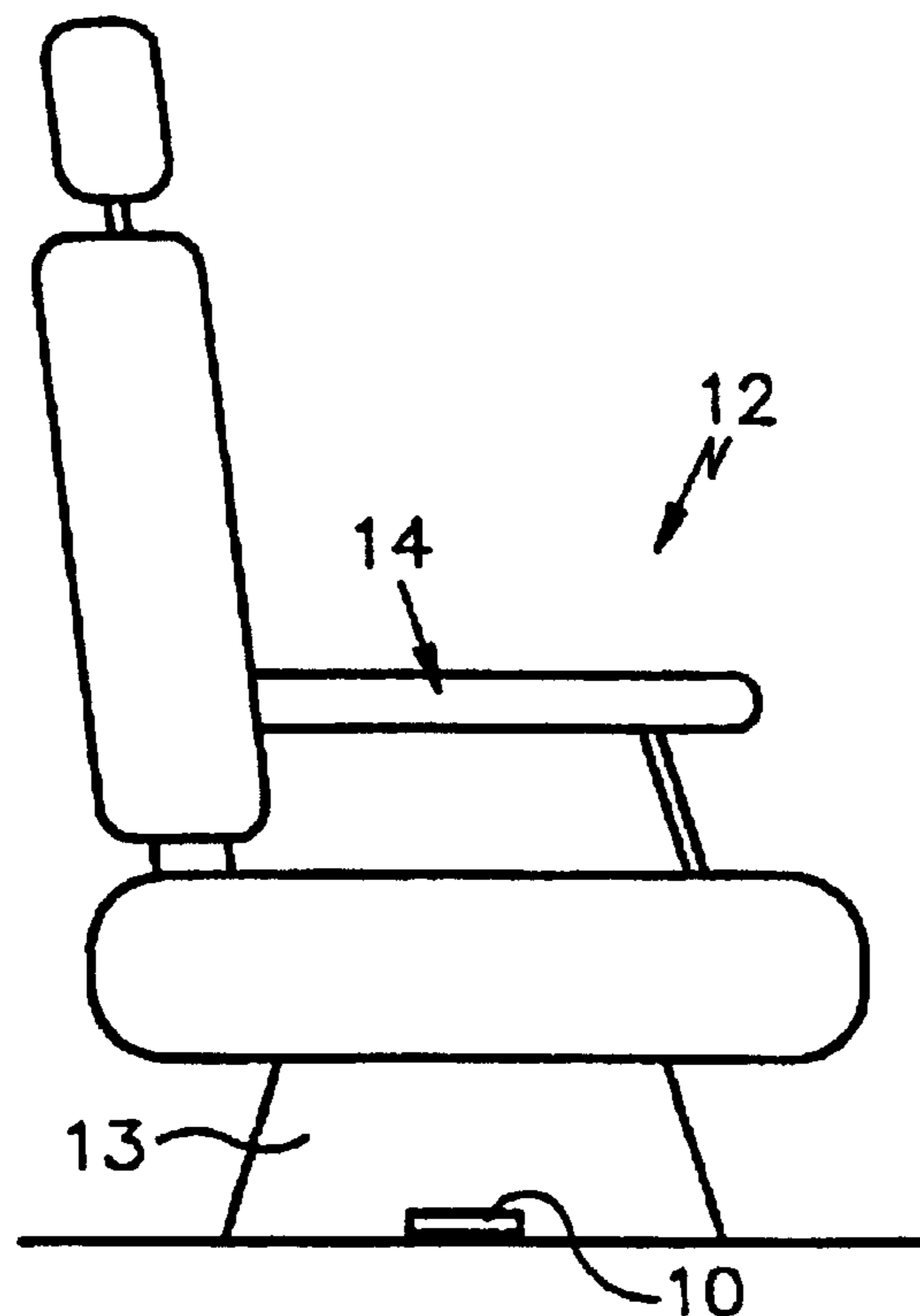

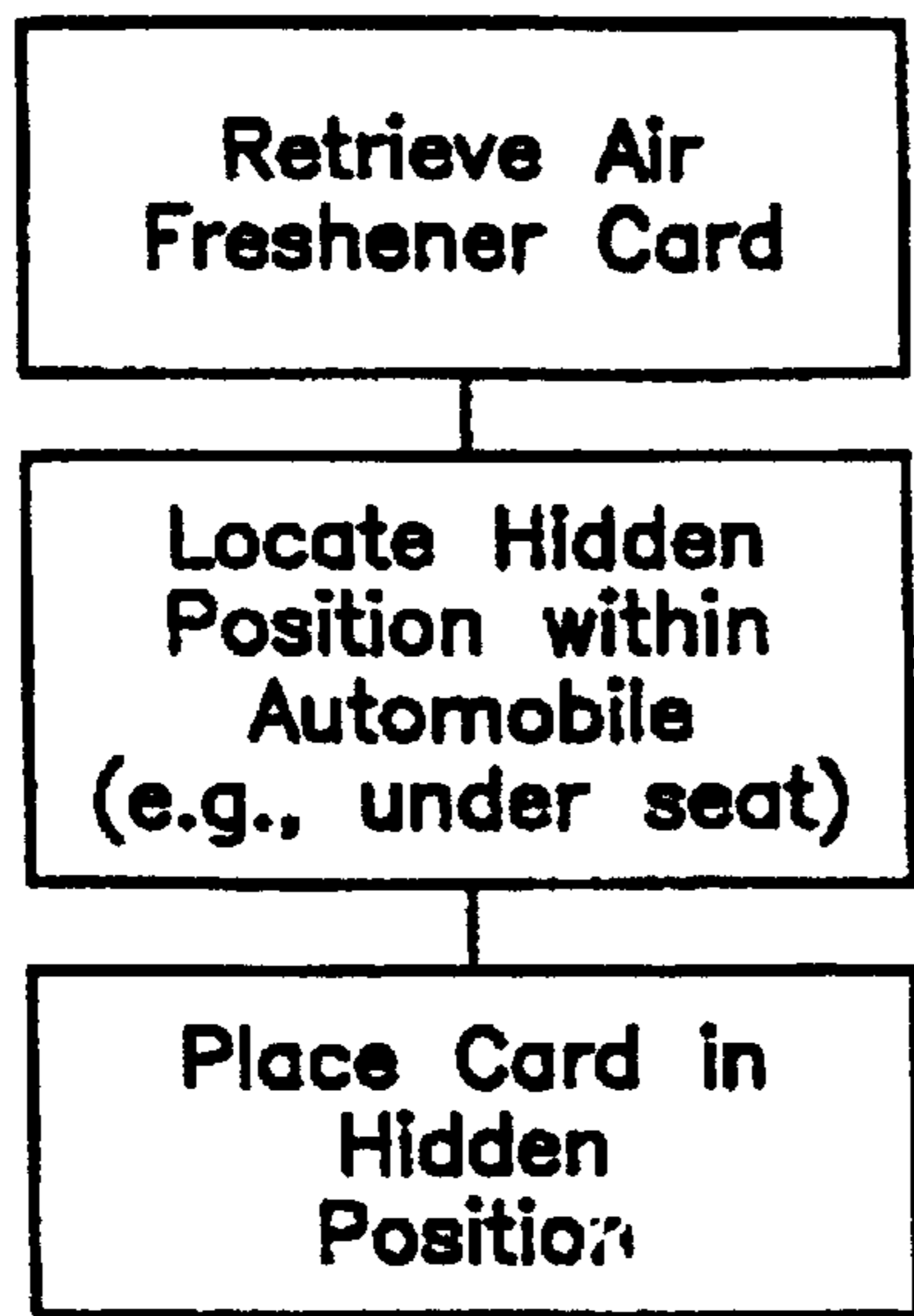

FIG. 1

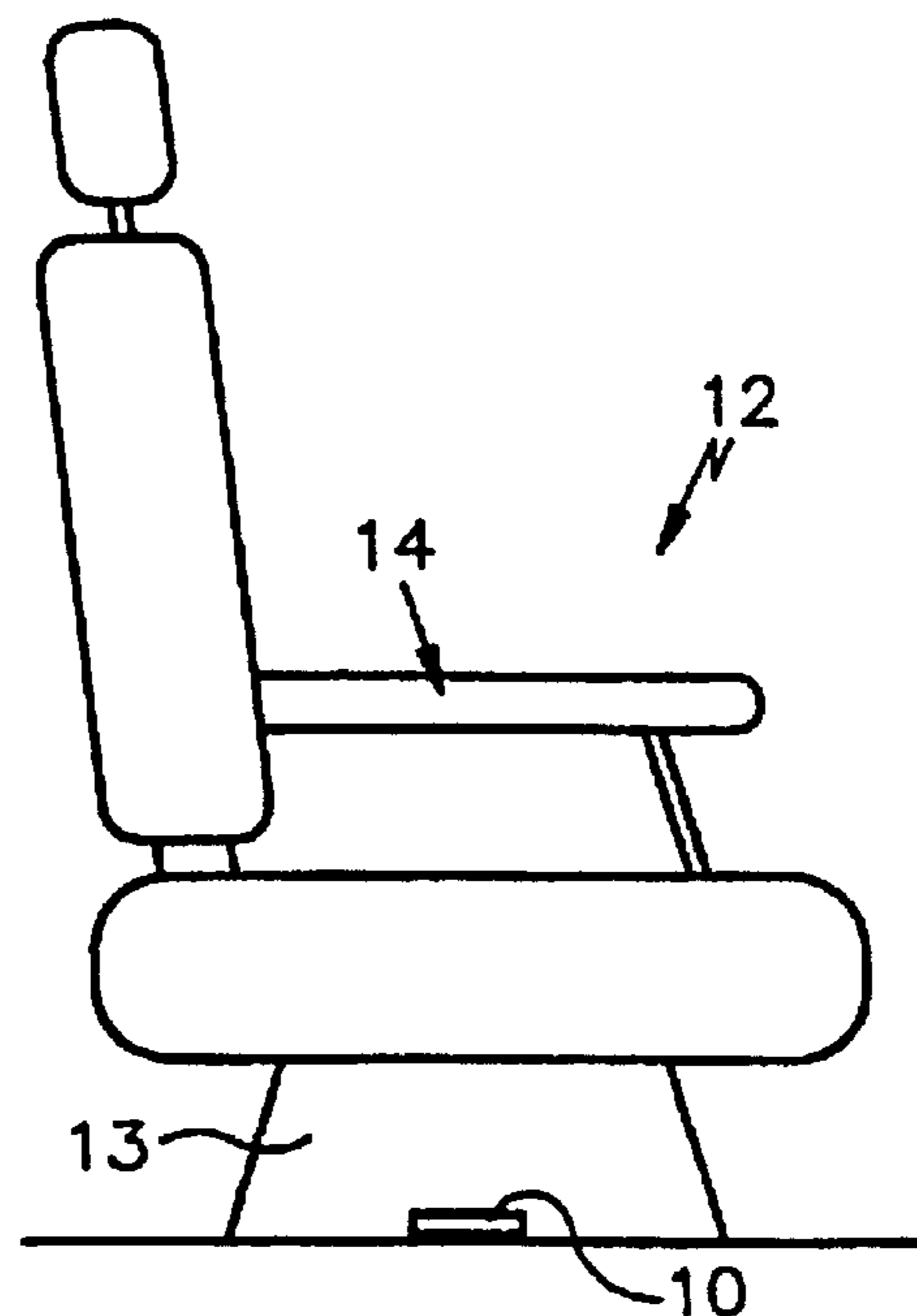

FIG. 2

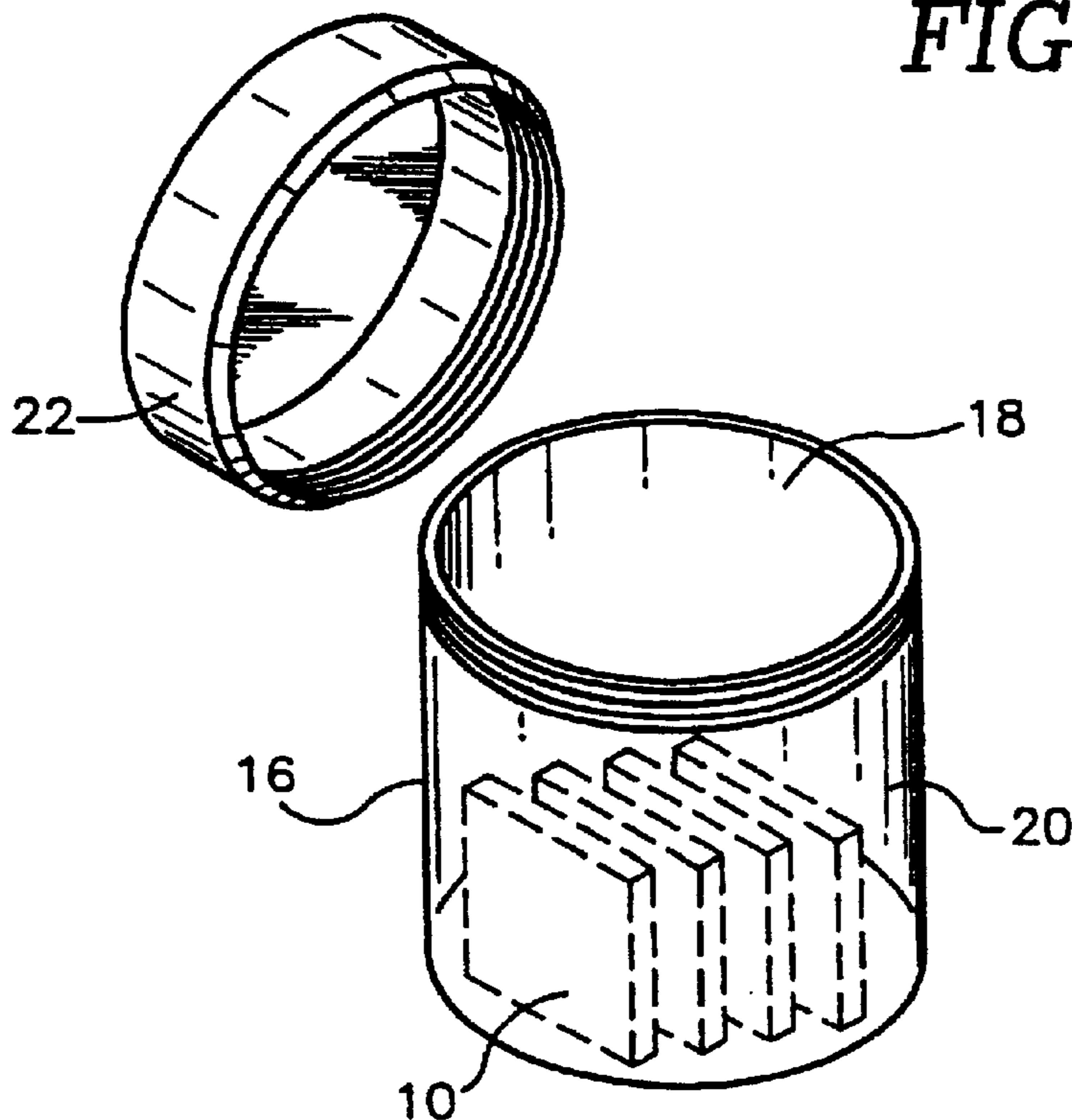

FIG. 3

**AIR FRESHENER CARD, METHOD OF USE
AND METHOD OF MANUFACTURE**

Matter enclosed in heavy brackets [] appears in the original patent but forms no part of this reissue specification; matter printed in italics indicates the additions made by reissue.

BACKGROUND OF THE INVENTION

1. Field of the Invention

The invention relates to methods for applying air freshener within an automobile. The invention further relates to air fresheners and a dispensing assembly useful in performing the present method.

2. Description of the Prior Art

It has been common practice for many years to apply air freshener, or fragrance, within automobiles at carwashes and detailing centers. The air freshener is generally applied to freshen the smell within the automobile interior and lasts for approximately 1–2 days.

Air freshener is currently applied to liquid form and is generally sprayed under the seat of an automobile. Unfortunately, many operators applying the liquid air freshener are not very careful and the liquid air freshener often ends up on various undesirable portions of the automobile. For example, the liquid air freshener sometimes ends up on the dashboard of the automobile, where the liquid air freshener interacts with the plastic material of the dashboard to destroy the dashboard. When this occurs, the damage to the dashboard is irreparable and the only alternative is to replace the entire affected dashboard. The liquid air freshener also is inadvertently sprayed upon other undesirable portions of automobile interiors, necessitating costly repair and/or replacement of the damaged components.

The cost of replacing and repairing automobile interiors damaged by improperly applied liquid air freshener is generally borne by the owner of the carwash or detailing center and/or the manufacturing company for the liquid air freshener. As such, a great incentive exists to obviate the problem.

Training of employees helps in limiting the occurrence of damage to automobile interiors. However, training provides only limited success.

In addition to damaging automobile interiors, the formulation commonly employed with liquid air fresheners disperses the fragrance in an undesirable manner. For example, one known formulation includes approximately 80% by weight water, 10% by weight alcohol, 5–6% by weight surfactant, and 4–5% fragrance oil. The alcohol carrier of the formulation quickly vaporizes after the initial application and creates a very strong, often overwhelming, initial fragrance which rapidly diminishes thereafter.

Some operators may choose to use hanging air freshener hung from the review mirror of an automobile. Many people, however, find these air freshener cards distracting and/or unsightly, and choose not to use them within an automobile. In addition, the cost of providing hanging air fresheners is prohibitive when compared with the cost of simply spraying liquid air freshener. Specifically, the wholesale cost of hanging air fresheners is currently approximately \$.50, while a sprayed liquid air freshener application generally costs the carwash or detailing center less than \$0.06.

The use of hanging air fresheners in this manner is also undesirable from a marketing point of view. The fragrance from sprayed liquid air fresheners generally last a day or

two, while the fragrance from hanging air freshener generally lasts two to three weeks. If hanging air freshener were used as a replacement for sprayed liquid air freshener, countertop sales of hanging air fresheners would certainly decrease.

As such, a need exists for a convenient and reliable method for discretely applying air freshener to the interior of an automobile. The present invention provides such a method.

SUMMARY OF THE INVENTION

It is, therefore, an object of the present invention to provide a method for applying air freshener within an automobile. The method includes the steps of retrieving an air freshener card, locating a substantially hidden position within the automobile, and placing the air freshener card at the substantially hidden position.

It is also an object of the present invention to provide a method wherein the substantially hidden position is under a seat of the automobile.

It is another object of the present invention to provide a method wherein the substantially hidden position is under a front seat of the automobile.

It is a further object of the present invention to provide a method wherein the air freshener card is a piece of cardboard impregnated with liquid air freshener such that the liquid fragrance is substantially bound to the cardboard and will not leach therefrom.

It is also an object of the present invention to provide a method for preparing a plurality of air freshener cards. The method is achieved by placing a predetermined number of cards within a container, pouring a predetermined quantity of an air freshener formulation into the container, and sealing the container and allowing the air freshener formulation to saturate the cards.

It is another object of the present invention to provide a method wherein the cards are cardboard.

It is a further object of the present invention to provide a method wherein the air freshener formulation is composed of fragrance oil and hexylene glycol.

It is also an object of the present invention to provide a method wherein the air freshener formulation is composed of approximately 80–85% fragrance oil and 15–20% hexylene glycol.

It is another object of the present invention to provide a method wherein approximately 0.026 ounces of air freshener formulation is poured within the container for each card placed within the container.

It is a further object of the present invention to provide a method wherein approximately 250 cards and 6 M ounces of the air freshener formulation are placed within the container prior to sealing.

It is also an object of the present invention to provide an air freshener card including a substrate of cardboard impregnated with an air freshener formulation composed of fragrance oil and hexylene glycol.

It is another object of the present invention to provide an air freshener card wherein the cardboard is 100 lb. weight cardboard.

Other objects and advantages of the present invention will become apparent from the following detailed description when viewed in conjunction with the accompanying drawings, which set forth certain embodiments of the invention.

BRIEF DESCRIPTION OF THE DRAWINGS

FIG. 1 is a flowchart of the steps taken in accordance with the present invention.

FIG. 2 is a side view of an automobile with an air freshener card placed under the car seat in accordance with the present invention.

FIG. 3 is a perspective view of the container used in accordance with the present invention.

DESCRIPTION OF THE PREFERRED EMBODIMENTS

The detailed embodiment of the present invention is disclosed herein. It should be understood, however, that the disclosed embodiment is merely exemplary of the invention, which may be embodied in various forms. Therefore, the details disclosed herein are not to be interpreted as limited, but merely as the basis for the claims and as a basis for teaching one skilled in the art how to make and/or use the invention.

With reference to FIGS. 1 and 2, the steps associated with the present method for applying air freshener within an automobile 12 are disclosed. In accordance with the invention, a non-liquid air freshener card 10 is applied within an automobile.

The present method allows operators of carwashes and automobile detailing shops to apply air fresheners within an automobile 12 without worrying that the applied air freshener will cause damage to the interior of the automobile 12.

The operator first retrieves an air freshener card 10. The card 10 is preferably a piece of cardboard impregnated with liquid air freshener such that the liquid fragrance is substantially bound to the cardboard and will not leach therefrom. In accordance with the present invention the air freshener formulation is composed of approximately 80–85% fragrance oil and 15–20% hexylene glycol. The air freshener formulation is saturated in a cardboard substrate in a manner discussed below in greater detail. As those skilled in the art will also appreciate, the present invention is not limited to specific air freshener fragrances, and a wide variety of fragrances may be used without departing from the spirit of the present invention.

The cardboard is preferably 100 lb. weight performance blotter manufactured by Crown Vantage, although other materials may be used without departing from the spirit of the invention.

The cardboard is preferably cut into approximately 2" square cards, although other size squares may be used without departing from the spirit of the present invention.

The combination of the air freshener formulation and the cardboard provide an ideal uniform release of the fragrance over the period of 3 to 4 days. As those skilled in the art will readily appreciate, variations in the formulation and cardboard may be made to suit specific applications without departing from the spirit.

The air freshener formulation is ideally suited for application to the cardboard employed in accordance with the preferred embodiment of the present invention. The cards are impregnated by placing a plurality of cards within a container 16, pouring a predetermined quantity of the air freshener formulation into the container 16 and closing the container for approximately 1 day. During this time, the cards absorbed the air freshener formulation and are ready for use.

In accordance with the preferred embodiment of the present invention, approximately 250 cards are placed

within the container 16 and 6½ ounces of the air freshener formulation is poured into the container. The container 16 is then sealed and allowed to sit for a predetermined period of time, for example, 1 day. During this time, the air freshener evenly distributes itself amongst the cards to produce 250 uniformly saturated air freshener cards. The impregnated cards 10 may be shipped for use within the same container 16 and no further processing is required.

Once an air freshener card 10 is retrieved, the operator locates a substantially hidden position within the automobile 12. In accordance with the preferred embodiment of the present invention, the best location is under 13 the front seat 14 of the automobile 12. Positioning the air freshener card under the seat of an automobile 12 is considered ideal in accordance with the present invention. Specifically, by placing the air freshener card 10 under the seat 14, the air freshener card 10 is completely out of sight and substantially hidden from small children. In addition, the operator of the carwash or detailing center need not enter the automobile 12 to place the air freshener card 10 in position.

The air freshener card 10 is then placed at the substantially hidden position, and the process is complete. As discussed above, because liquid air freshener is not sprayed in accordance with the present invention, there is no fear that the air freshener will be inadvertently sprayed upon an interior surface of an automobile not compatible with the air freshener.

In addition, the air freshener card 10 is hidden and, therefore, not visible or distracting to the owner of the automobile.

Retrieval, manufacture and shipping of the air freshener cards 10 used in accordance with the present invention is facilitated by providing an air freshener card dispensing container 16 as shown in FIG. 3. The container is substantially airtight and includes an access opening 18 providing access to an interior cavity 20 of the container 16.

The access opening 18 is selectively sealed by a screw on cover 22 shaped and dimensioned to selectively seal the access opening 18. While a screw on cover is disclosed in accordance with the preferred embodiment of the present invention, the cap may be sealed in a variety of ways, for example, flip top cap or snap on cap, without departing from the spirit of the present invention.

A plurality of air freshener cards 10 are stored within the container 16 for ready retrieval by the operator of the carwash or detailing center.

While the preferred embodiments have been shown and described, it will be understood that there is no intent to limit the invention by such disclosure, but rather, is intended to cover all modifications and alternate constructions falling within the spirit and scope of the invention as defined in the appended claims.

What is claimed is:

1. A method for applying air freshener within an automobile, comprising:
 - retrieving an air freshener card, the air freshener card including a substrate of cardboard impregnated with a liquid air freshener formulation composed of approximately 80–85% fragrance oil and 15–20% hexylene glycol to provide a uniform release of the air freshener formulation;
 - locating a substantially hidden position within the automobile; and
 - placing the air freshener card at the substantially hidden position.

5

2. The method according to claim 1, wherein the substantially hidden position is under a seat of the automobile.

3. The method according to claim 1, wherein the substantially hidden position is under a front seat of the automobile.

4. The method according to claim 1, wherein the air freshener card is a piece of cardboard impregnated with [a] the liquid [fragrance] air freshener formulation such that the liquid [fragrance] air freshener formulation is substantially bound to the cardboard and will not leach therefrom.

5. The method according to claim 1, wherein the cardboard is 100 lb. weight cardboard.

6. The method according to 1, wherein the air freshener card is impregnated with approximately 0.026 ounces of the air freshener formulation.

7. A method for the manufacture, shipping and retrieval of air freshener cards used in the operation of car washes and automobile detailing shops in the treatment of automobiles being serviced thereby, comprising the following steps:

placing a predetermined number of cards within a container,

pouring a predetermined quantity of a liquid air freshener formulation into the container, said liquid air freshener formulation composed of approximately 80-85% fragrance oil and 15-20% hexylene glycol;

sealing the container for a predetermined period of time and allowing the air freshener formulation to saturate the cards, thereby forming a plurality of air freshener cards composed of the cards impregnated with the liquid air freshener formulation such that the liquid air freshener formulation is substantially bound to the cards and will not leach therefrom;

shipping the container, including the air freshener cards, to a location where automobiles are serviced to thereby provide ready access to the air freshener cards contained therein;

after complete saturation of the cards, retrieving an air freshener card;

locating a hidden position under a seat of an automobile; positioning the air freshener card under the seat of the automobile.

6

8. The method according to claim 7, wherein the cards are pieces of cardboard impregnated with the liquid air freshener formulation such that the liquid air freshener formulation is substantially bound to the cardboard and will not leach therefrom.

9. The method according to claim 8, wherein the cardboard is 100 lb. weight cardboard.

10. The method according to claim 7, wherein each air freshener card is impregnated with approximately 0.026 ounces of the liquid air freshener formulation.

11. An air freshener card dispensing system for use by the operators of car washes and automobile detailing shops allowing the ready provision of air freshener cards shaped and dimensioned for placement at hidden position within automobiles being serviced thereby, comprising:

a plurality of cards stored within a container;

a liquid air freshener formulation within the container and in contact with the plurality of cards, the liquid air freshener formulation saturating the cards to form air freshener cards, the liquid air freshener formulation composed of approximately 80-85% fragrance oil and 15-20% hexylene glycol to provide a uniform release of the air freshener formulation upon removal from the container, and

the container being substantially airtight and including a selectively sealed access opening allowing ready retrieval of air freshener cards by operators of the car washes and automobile shops.

12. The system according to claim 11, wherein the cards are pieces of cardboard impregnated with the liquid air freshener formulation such that the liquid air freshener formulation is substantially bound to the cardboard and will not leach therefrom.

13. The system according to claim 12, wherein the cardboard is 100 lb. weight cardboard.

14. The system according to claim 11, wherein each air freshener card is impregnated with approximately 0.026 ounces of the liquid air freshener formulation.

* * * * *