



US00RE39368E

(19) **United States**  
(12) **Reissued Patent**  
**Alcorn et al.**

(10) **Patent Number: US RE39,368 E**  
(45) **Date of Reissued Patent: Oct. 31, 2006**

(54) **ELECTRONIC CASINO GAMING SYSTEM WITH IMPROVED PLAY CAPACITY, AUTHENTICATION AND SECURITY**  
(75) Inventors: **Allan E. Alcorn**, Portola Valley, CA (US); **Michael Barnett**, San Carlos, CA (US); **Louis D. Giacalone, Jr.**, Henderson, NV (US); **Adam E. Levinthal**, Redwood City, CA (US)

(56) **References Cited**  
U.S. PATENT DOCUMENTS  
3,825,905 A 7/1974 Allen, Jr. .... 340/172.5  
3,838,264 A 9/1974 Maker ..... 253/153  
4,193,131 A 3/1980 Lennon et al. .... 375/2

(Continued)

**FOREIGN PATENT DOCUMENTS**

(73) Assignee: **IGT**, Reno, NV (US)  
(21) Appl. No.: **10/224,680**  
(22) PCT Filed: **Jun. 17, 1996**  
(86) PCT No.: **PCT/US96/10463**

EP 0 685 246 A1 12/1995  
GB 2 121 569 12/1983  
JP 6-327831 11/1994  
JP 7-31737 2/1995  
WO WO 99/65579 \* 12/1999  
WO WO 00/33196 \* 6/2000

§ 371 (c)(1),  
(2), (4) Date: **Mar. 10, 1998**

**OTHER PUBLICATIONS**

(87) PCT Pub. No.: **WO97/01902**  
PCT Pub. Date: **Jan. 16, 1997**

Bakhtiari et al., Cryptographic Hash Functions: A Survey, 1995, Centre for Computer Security Research, pp. 1-26.\*  
Bauspiess, et al., "Requirements For Cryptographic Hash Functions," *Computers and Security*, 5:427-437 (Sep. 11, 1992).

**Related U.S. Patent Documents**

(Continued)

Reissue of:  
(64) Patent No.: **6,106,396**  
Issued: **Aug. 22, 2000**  
Appl. No.: **08/981,882**  
Filed: **Mar. 10, 1998**

*Primary Examiner*—John M. Hotaling, II  
(74) *Attorney, Agent, or Firm*—Beyer Weaver & Thomas LLP

U.S. Applications:  
(

(57) **ABSTRACT**

(63) Continuation-in-part of application No. 08/497,662, filed on Jun. 29, 1995, now Pat. No. 5,643,086.

The electronic casino gaming system consists of several system components, including a microprocessor (12), a main memory unit (13) that is typically a random access memory, and a system boot ROM (14). Also included in the electronic casino gaming system are a non-volatile RAM (17), a mass storage unit (18), a disk subsystem (19), and a PCI bus (20). The disk subsystem (19) preferably supports SCSI-2 with options of fast and wide. A video subsystem (22) is also included in the electronic casino gaming system and is coupled to the PCI bus (20) to provide full color still images and MPEG movies.

(51) **Int. Cl.**  
**A63F 13/00** (2006.01)  
**G06F 5/00** (2006.01)

(52) **U.S. Cl.** ..... **463/29; 380/25**

(58) **Field of Classification Search** ..... 463/20,  
463/25, 29, 40-44, 1, 16; 700/91; 380/251,  
380/4, 9, 23, 25, 30, 49, 50, 59

See application file for complete search history.

**73 Claims, 3 Drawing Sheets**

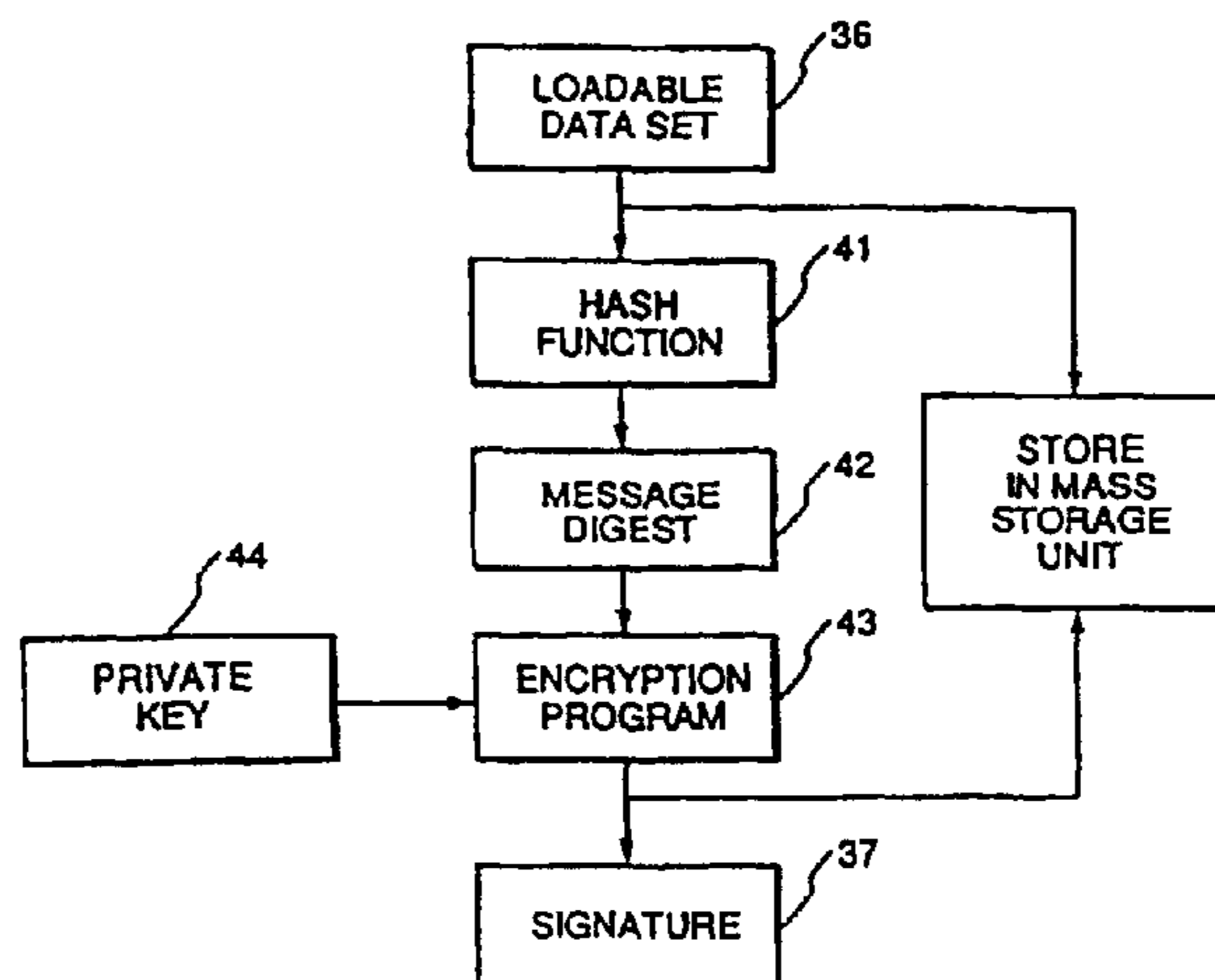



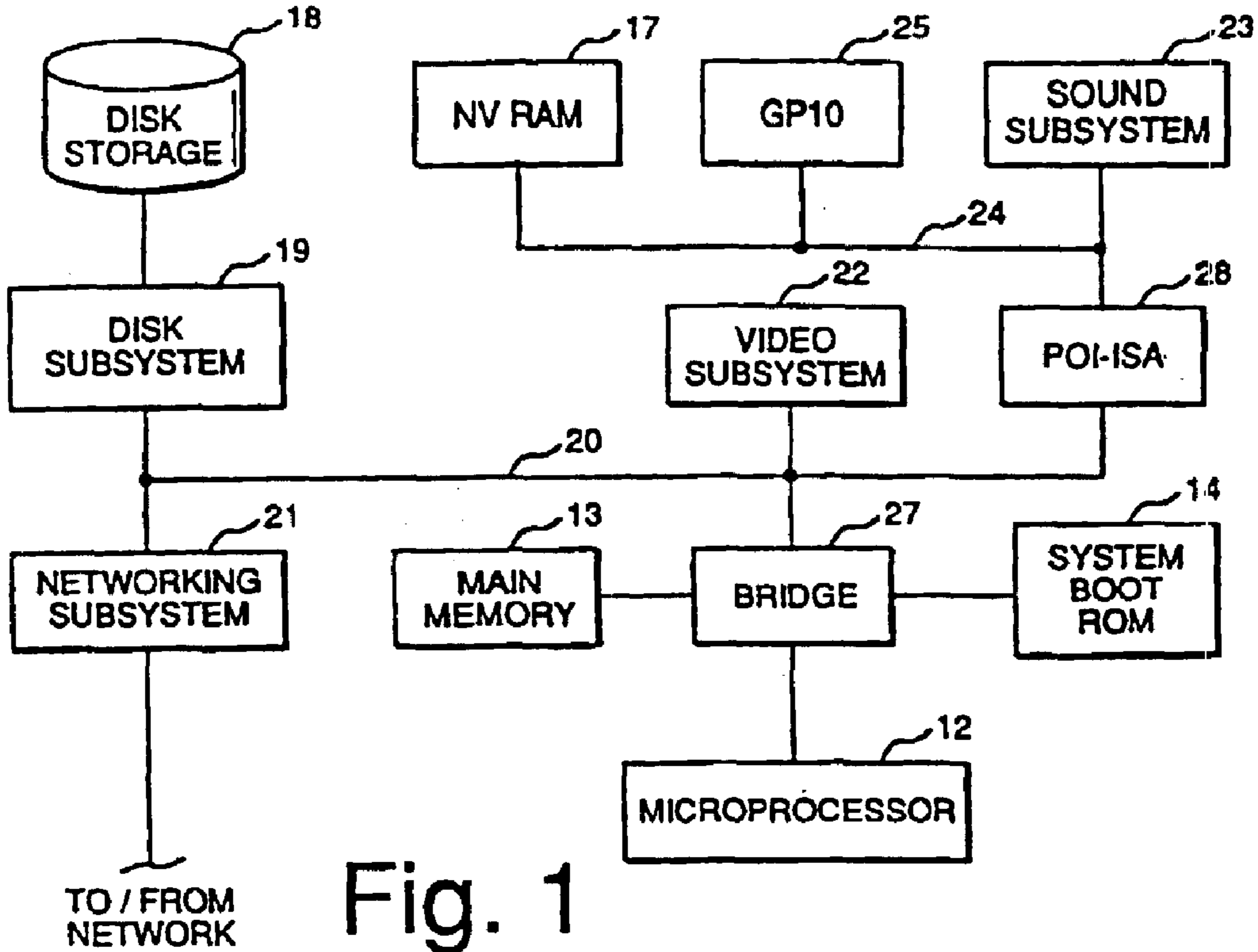

Fig. 1

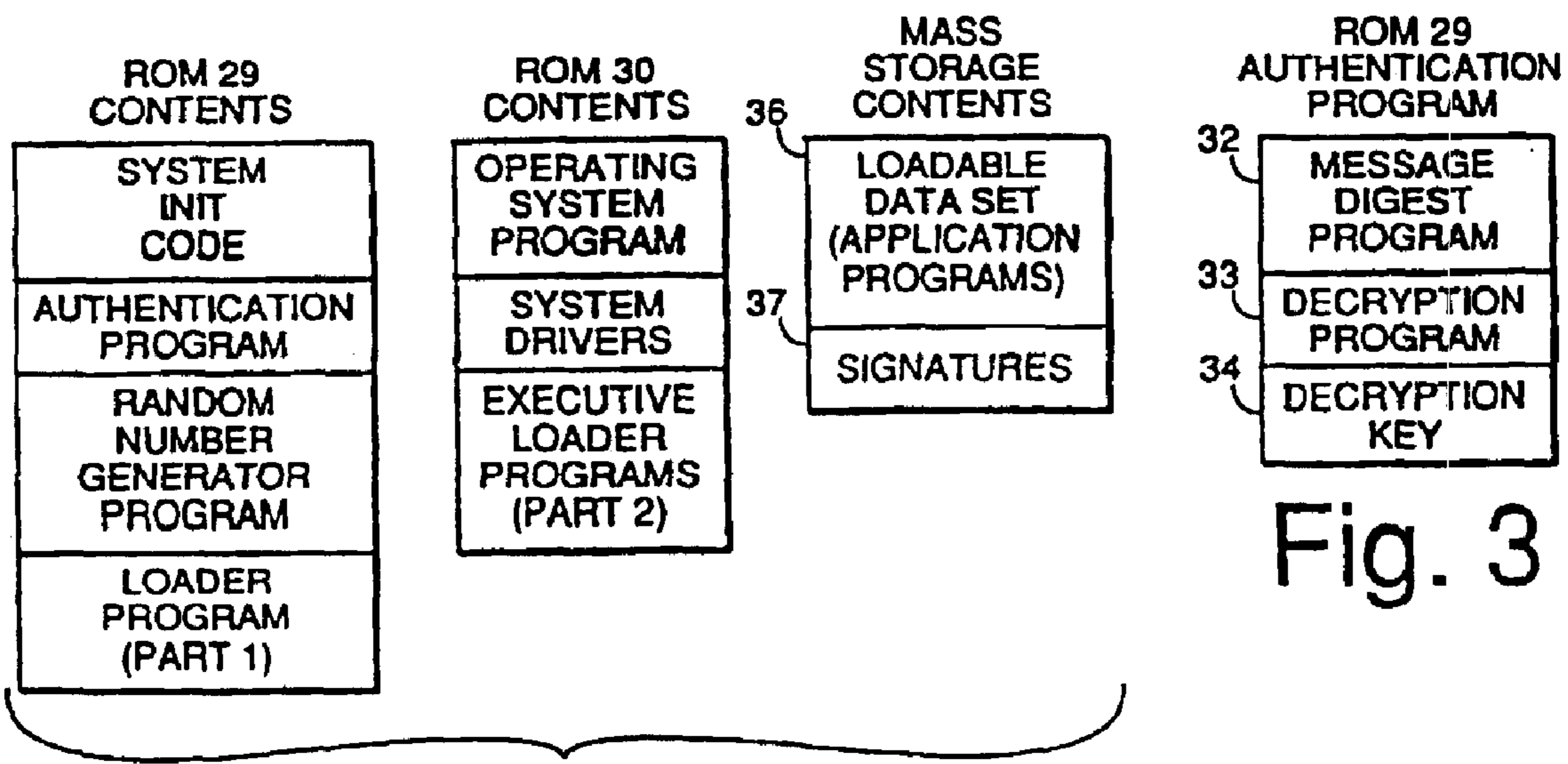

Fig. 2

Fig. 3

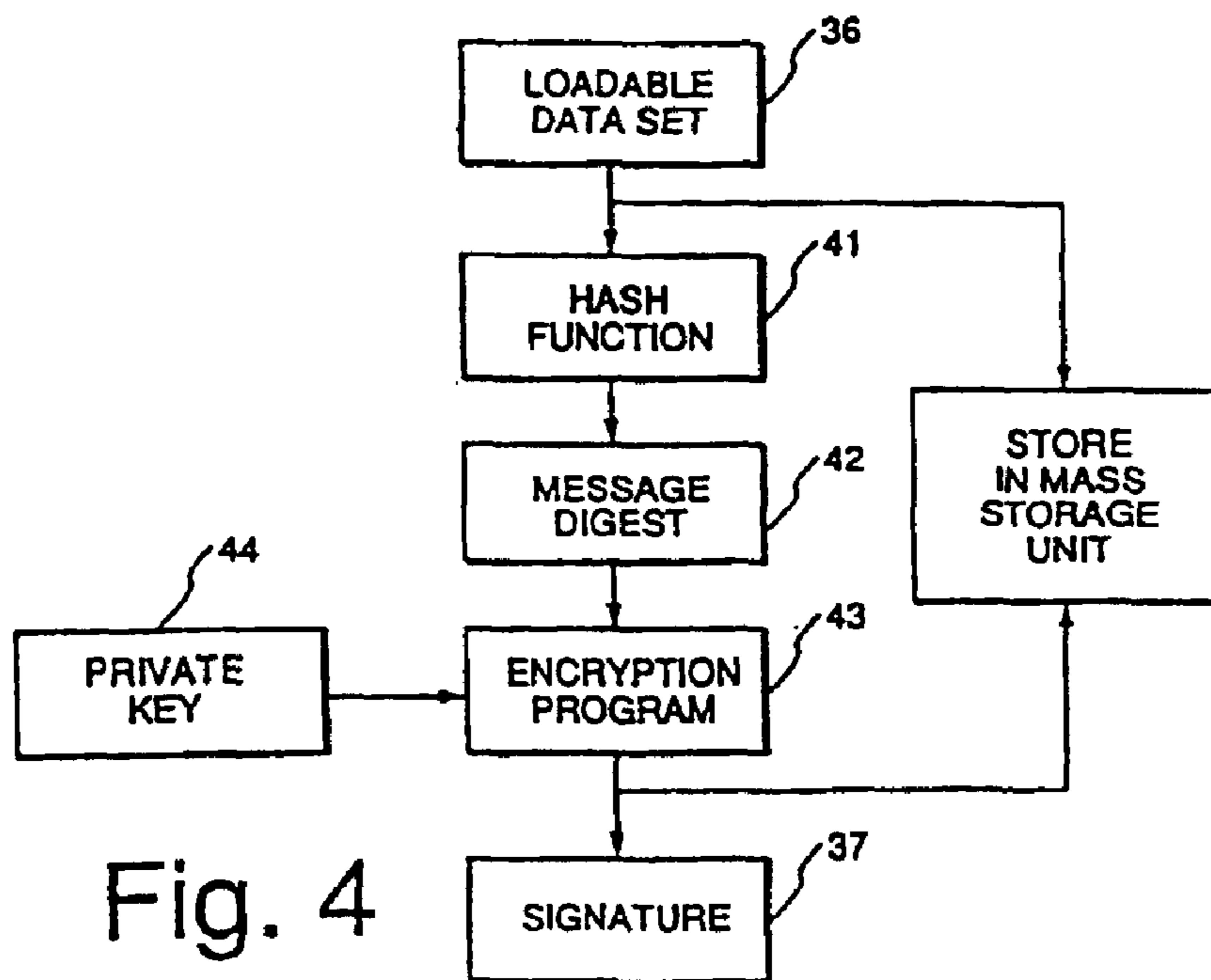

Fig. 4

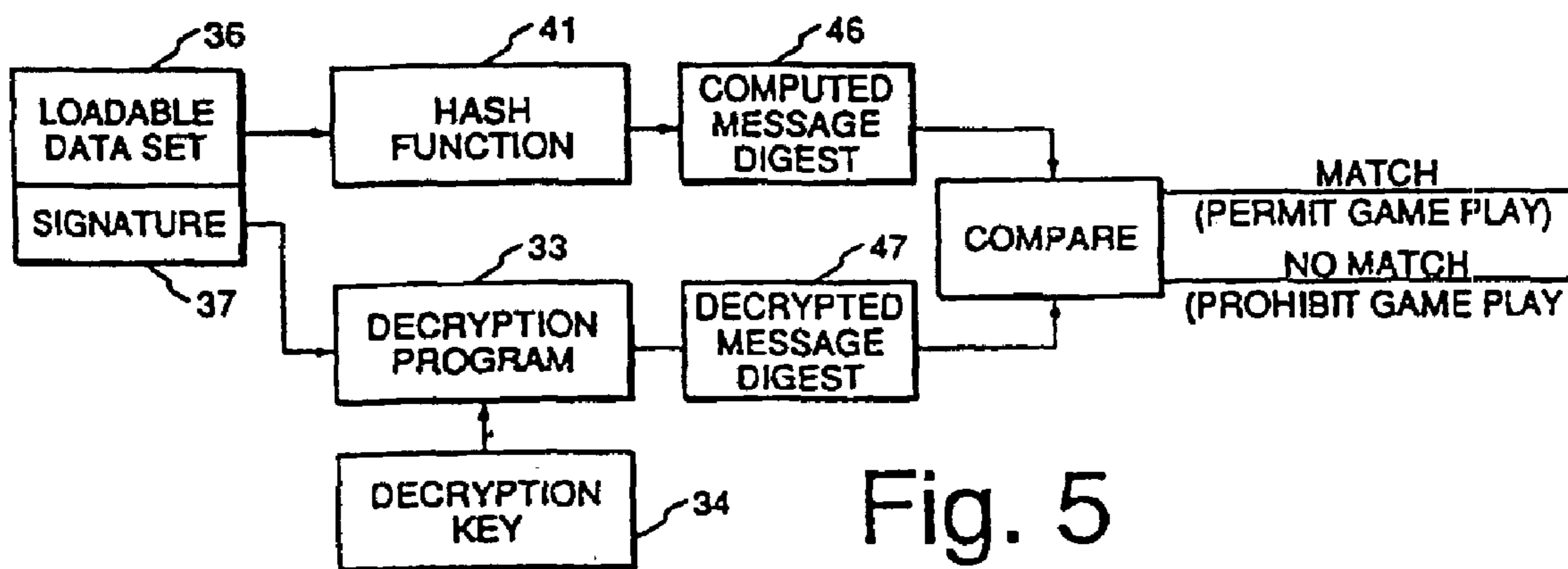

Fig. 5

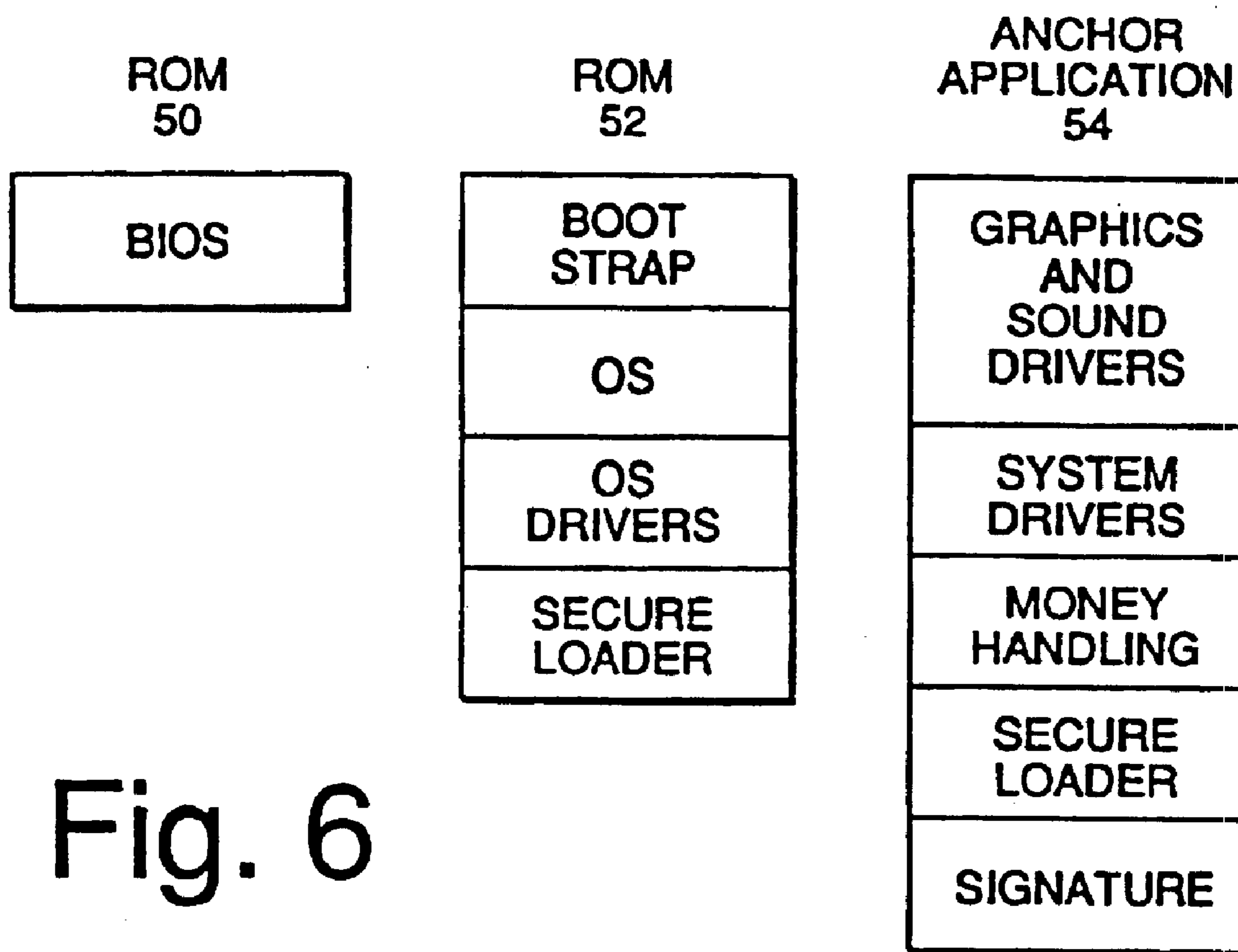

Fig. 6

**ELECTRONIC CASINO GAMING SYSTEM  
WITH IMPROVED PLAY CAPACITY,  
AUTHENTICATION AND SECURITY**

**Matter enclosed in heavy brackets [ ] appears in the original patent but forms no part of this reissue specification; matter printed in italics indicates the additions made by reissue.**

[This application is the national stage of International Application No. PCT/US96/10463, filed on Jun. 17, 1996, which is a continuation-in-part of U.S. application Ser. No. 08/497,662, now U.S. Pat. No. 5,643,086, filed on Jun. 29, 1995.] *Notice: More than one reissue application has been filed for the reissue of U.S. Pat. No. 6,106,396. The reissue applications are Reissue Application Ser. No. 10/225,096 filed Aug. 21, 2002, Reissue Application Ser. No. 10/224,680 filed Aug. 21, 2002 (the present application), Reissue Application Ser. No. 10/225,116 filed Aug. 21, 2002, Reissue Application Ser. No. 10/225,097 filed Aug. 21, 2002 and Reissue Application Ser. No. 10/224,699 filed Aug. 21, 2002, all of which are divisional reissues of U.S. Pat. No. 6,106,396, which issued from U.S. Ser. No. 08/981,882 which is the U.S. national phase of International Application No. PCT/US96/10463 filed Jun. 17, 1996, which is a continuation-in-part of U.S. Ser. No. 08/497,662 filed Jun. 29, 1995, now U.S. Pat. No. 5,643,086.*

**BACKGROUND OF THE INVENTION**

**1. Field of the Invention**

This invention relates to microprocessor based gaming Systems used in gambling casinos.

**2. Brief Description of the Prior Art**

Microprocessor based gaming systems are known which are used in gambling casinos to augment the traditional slot machine games (e.g. three reel single or multi-line games) and card games, such as poker and black jack. In a typical gaming systems of this type, a microprocessor based system includes both hardware and software components to provide the game playing capabilities. The hardware components include a video display for displaying the game play, mechanical switches for enabling player selection of additional cards or game play choices, coin acceptors and detectors and the electronic components usually found in a microprocessor based system, such as random access memory (RAM), read only memory (ROM), a processor and one or more busses. The software components include the initialization software, credit and payout routines, the game image and rules data set, and a random number generator algorithm. In order to be acceptable for casino use, an electronic gaming system must provide both security and authentication for the software compounds. For this reason, gaming commissions have heretofore required that all software components of an electronic gaming system be stored in unalterable memory, which is typically an unalterable ROM. In addition, a copy of the contents of the ROM or a message digest of the contents (or both) are normally kept on file in a secure location designated by the gaming commission so that the contents of an individual ROM removed from a gaming machine can be verified against the custodial version.

In a typical arrangement, a message digest of the ROM contents is initially generated prior to the installation of the ROM in the machine by using a known algorithm usually referred to as a hash function. A hash function is a computation procedure that produces a fixed-size string of bits from a variable-size digital input. The fixed-sized string of

bits is termed the hash value. If the hash function is difficult to invert—termed a one-way hash function—the hash function is also termed a message digest function, and the result is termed the message digest. The message digest is unique to any given variable size input data set, i.e., the game data set stored in the ROM. When it becomes necessary to later authenticate the ROM from any given machine, the ROM is physically removed from the game console and the message digest of the ROM contents is computed directly from the ROM using the original hash function. The computed message digest is compared with the message digest on file at the designated custodial location (typically in the casino itself). This procedure is typically carried out whenever a machine produces a payoff beyond a given threshold value. If the two message digests match, then the contents of the ROM are considered to be authenticated (verified) and the payout is made to the player.

While such electronic casino gaming systems have been found to be useful in promoting casino game play, the restriction requiring that the casino game program be stored in unalterable ROM memory, leads to a number of disadvantageous limitations. First, due to the limited capacity of the ROM storage media traditionally used to hold the program, the scope of game play available with such systems is severely limited. For sophisticated games using motion video and audio multi-media elements, much more memory capacity, on the order of hundreds of megabytes, is necessary. However, physical verification of such a large quantity of physical devices is not practical, and has thus far been an impediment to creating sophisticated games with more player appeal. Second, the authentication check is only conducted on a limited basis (usually after a jackpot) or other significant winning game outcome, and the authentication procedure requires that game play be halted until the ROM contents have been found to be authentic.

**SUMMARY OF THE INVENTION**

[The invention comprises an electronic casino gaming system which greatly expands casino game play capability and enhances security and authentication capabilities. More particularly, the invention comprises an electronic casino gaming system and method having greatly expanded mass storage capability for storing a multiplicity of high resolution, high sound quality casino type games, and provides enhanced authentication of the stored game program information with a high security factor.]

[According to a first aspect of the invention, authentication of a casino game data set is carried out within the casino game console using an authentication program stored in an unalterable ROM physically located within the casino game console. The casino game data set and a unique signature are stored in a mass storage device, which may comprise a read only unit or a read/write unit and which may be physically located either within the casino game console or remotely located and linked to the casino game console over a suitable network. The authentication program stored in the unalterable ROM performs an authentication check on the casino game data set at appropriate times, such as prior to commencement of game play, at periodic intervals or upon demand. At appropriate occasions, the contents of the unalterable ROM can be verified by computing the message digest of the unalterable ROM contents and comparing this computed message digest with a securely stored copy of the message digest computed from the ROM contents prior to installation in the casino game console.]

[From a process standpoint, this aspect of the invention comprises a method of authenticating a data set of a casino

3

style game which consists of two phases: a game data set preparation phase and a game data set checking phase. In the game data set preparation phase, the method proceeds by providing a data set for a casino game, computing a first abbreviated bit string unique to the casino game data set, encrypting the first abbreviated bit string to provide an encrypted signature of the casino game data set, and storing the casino game data set and the signature in a mass storage device. The first abbreviated bit string is preferably computed using a hash function to produce a message digest of the casino game data set. The signature is then encrypted from the message digest. After storage of the game data set and unique signature, this information is installed in a casino game console. The casino game data set checking phase proceeds by computing a second abbreviated bit string from the stored casino game data set using the same hash function, decrypting the stored encrypted signature to recover the first abbreviated bit string, and comparing the first and second abbreviated bit strings to determine whether the two strings match. If a match does occur the casino game data set is deemed authentic; if there is no match, authentication is denied and game play is prohibited.]

[The encryption/decryption process is preferably performed using a private key/public key technique in which the first abbreviated bit string is encrypted by the game manufacturer using a private encryption key maintained in the custody of the game manufacturer. The decryption of the signature is performed using a public key which is contained in an unalterable read only memory element located in the game console, along with the casino game data set. The casino game data set is preferably stored in a mass storage device, such as a magnetic or CD-ROM disk drive unit or a network file unit, the selected unit having a relatively large capacity. The actual size of the mass storage device will depend upon the casino game storage requirements and can be tailored to any specific application.]

[Each time a casino game data set is transferred from the mass storage device to the main memory of the system, the authentication routine is run. The authentication routine can also be means of an operator switch mounted in the game console or remotely via a network. Consequently, the authenticity of the data set can be automatically checked whenever the transfer occurs and at other appropriate times.]

[In order to detect attempts to tamper with the contents of the unalterable read only memory element located in the game console, a message digest computed for the authentication program stored therein is stored in a secure manner in a different location from the game console, such as the casino operator's security facilities or the facilities of a gaming commission (or both). The authenticity of the unalterable read only memory element is checked in the same way as that now performed in prior art devices: viz. computing the message digest directly from the unalterable read only memory device, and comparing the message digest thus computed with the custodial version.]

[From an apparatus standpoint, the first aspect of the invention comprises an electronic casino gaming system having means for providing authentication of a game data set of a casino type game prior to permitting game play, the system including first means for storing a casino game data set and a signature of the casino game data set, the signature comprising an encrypted version of a unique first abbreviated bit string computed from the casino game data set; second means for storing an authentication program capable of computing a second abbreviated bit string from the casino game data set stored in the first storing means and capable of decrypting the encrypted signature stored in the first

4

storing means to recover the first abbreviated bit string; processing means for enabling the authentication program to compute an abbreviated bit string from the casino game data set stored in the first storing means and for enabling the authentication program to decrypt the encrypted signature; and means for comparing the computed second abbreviated bit string with the decrypted abbreviated bit string to determine whether a match is present. The first storing means preferably comprises a mass storage device, such as a disk drive unit, a CD-ROM unit or a network storage unit. The second storing means preferably comprises an unalterable read only memory in which the authentication program is stored.]

[According to a second aspect of the invention, the authentication program stored in the unalterable ROM located within the casino game console is used to test the authenticity of all other programs and fixed data stored in memory devices in the electronic casino gaming system, such as a system boot ROM, memory devices containing the operating system program, system drivers and executive/loader programs, and other memory devices incorporated into the electronic casino game system architecture. The contents of each such memory device, whether program information or fixed data, include signatures encrypted from message digests computed using a hash function from the original program information or fixed data set. Upon system initialization, the authentication program in the unalterable ROM is used to authenticate the individual memory device contents in essentially the same fashion as that used to authenticate the casino game data sets. More specifically, the message digest for the given program or fixed data set is computed using the same hash function originally used to produce the message digest for that program or fixed data set. The encrypted signature is decrypted using the proper decryption program and decryption key to recover the message digest. The two versions of the message digest are then compared and, if found to be matching, the concerned program or fixed data set is deemed authentic and is permitted to be used by the system. Once all of the concerned programs and fixed data sets have been so authenticated, the casino game data set authentication procedure is run, after which game play is permitted (provided a match occurs).]

[From a process standpoint, this second aspect of the invention comprises a method of authenticating a program or data set of a casino style game which consists of two phases: a program or fixed data set preparation phase, and a program or fixed data set checking phase. In the program or fixed data set preparation phase, the method proceeds by providing a program or fixed data set for a casino game, computing a first abbreviated bit string unique to the program or fixed data set, encrypting the first abbreviated bit string to provide an encrypted signature of the program or fixed data set, and storing the program or fixed data set and the signature in a memory device. The first abbreviated bit string is preferably computed using a hash function to produce a message digest of the program or fixed data set. The signature is then encrypted from the message digest. After storage of the program or fixed data set and unique signature in the memory device, the memory device is installed in a casino game console. The casino game program or fixed data set checking phase proceeds by computing a second abbreviated bit string from the stored casino game program or fixed data set stored in the memory device using the same hash function, decrypting the encrypted signature stored in the memory device to recover the first abbreviated bit string, and comparing the first and second abbreviated bit strings to determine whether the two strings

5

match. If a match does occur, the casino game program or fixed data set is deemed authentic; if there is no match, authentication is denied and use of that casino game program or fixed data set is prohibited.]

[The authentication routine is run each time a given casino game program or fixed data set needs to be called or used. The authentication routine can also be run automatically on a periodic basis, or on demand—either locally by means of an operator switch mounted in the casino game console or remotely via a network. Consequently, the authenticity of the casino game program or fixed data set can be automatically checked whenever use of that program or fixed data set is required and at other appropriate times, such as in the course of a gaming commission audit.]

[From an apparatus standpoint this second aspect of the invention comprises an electronic casino gaming system for providing authentication of a casino game program or fixed data set prior to permitting system use of that casino game program or fixed data set, the system including first means for storing a casino game program or fixed data set and a signature of the casino game program or fixed data set; the signature comprising an encrypted version of a unique first abbreviated bit string computed from the casino game program or fixed data set; second means for storing an authentication program capable of computing a second abbreviated bit string from the casino game program or fixed data set stored in the first storing means and capable of decrypting the encrypted signature stored in the first storing means to recover the first abbreviated bit string; processing means for enabling the authentication program to compute an abbreviated bit string from the casino game program or fixed data set stored in the first storing means and for enabling the authentication program to decrypt the encrypted signature; and means for comparing the computed second abbreviated bit string with the decrypted abbreviated bit string to determine whether a match is present. The first storing means preferably comprises a memory device, such as a read only memory or random access memory. The second storing means preferably comprises an unalterable read only memory in which the authentication program is stored.]

[Electronic casino game systems incorporating the invention provide a vastly expanded capacity for more sophisticated and attractive casino-style games, while at the same time improving the authentication of the games without compromising security. In addition, casino game systems incorporating the invention provide great flexibility in changing casino game play, since the casino game data sets representing the various games can be stored in alterable media rather than read only memory units as with present casino game systems.]

[By separating the authentication process from the casino game data set storage, the invention affords secure distribution and execution of program code and data, regardless of the particular distribution or storage technique employed. More specifically, the invention allows the casino game data set to reside in any form of secondary storage media, such as the traditional ROM storage, hard magnetic disk drives and CD-ROM drives, or networked file systems. So long as the authentication procedure conducted on the game data set is performed using the authentication program stored in an unalterable ROM, and so long as that ROM can be verified reliably, any casino game data set can be loaded from any source and can be verified by the system at any time: either prior to use, during run-time, periodically during run-time or upon demand. The large quantities of storage that can be made available in a secure fashion using the invention,

6

facilitates the creation of casino gaming systems offering both an increased diversity of games, and individual games of superior quality. In addition, the authentication of all casino game program and fixed data software ensures the integrity of all system software both prior to game play and thereafter at periodic or random intervals.]

[For a fuller understanding of the nature and advantages of the invention, reference should be had to the ensuing detailed description taken in conjunction with the accompanying drawings.]

*In one aspect, the invention is directed to a casino gaming apparatus, comprising: a casino game console; a video display unit; a read/write memory having a data storage capacity, said read/write memory being disposed in said casino game console; a disk memory having a data storage capacity that is larger than said data storage capacity of said read/write memory, said disk memory having gaming data relating to a casino game stored therein, said disk memory being disposed in said casino game console; and a processor disposed in said casino game console and being operatively coupled to said video display unit, said read/write memory and said disk memory, said processor causing said gaming data to be checked based on a comparison of data generated by said processor from said gaming data with previously generated data, and said processor causing a remedial action to be taken based on an outcome of said checking of said gaming data.*

*In another aspect, the invention is directed to a casino gaming apparatus, comprising: a casino game console; a video display unit; a sound-generating apparatus; a read/write memory having a data storage capacity, said read/write memory being disposed in said casino game console; a nonvolatile memory that stores gaming data; a disk memory having a data storage capacity that is larger than said data storage capacity of said read/write memory, said disk memory having gaming data relating to a casino game stored therein, said disk memory being disposed in said casino game console; and a processor disposed in said casino game console and being operatively coupled to said video display unit, said sound-generating apparatus, said read/write memory, said nonvolatile memory and said disk memory, said processor causing said gaming data stored in said disk memory to be transferred to said read/write memory, said processor causing said gaming data that was transferred from said disk memory to said read/write memory to be authenticated based on comparison of a message digest generated by performing a one-way hash function on said gaming data being authenticated with a message digest previously generated by performing a one-way hash function on known gaming data, each of said one-way hash functions producing a fixed-size string of bits, and said processor causing a remedial action to be taken if said gaming data transferred from said disk memory to said read/write memory is not authentic as determined by said processor.*

*Other aspects of the invention are defined by the claims set forth at the end of this patent.*

#### BRIEF DESCRIPTION OF THE DRAWINGS

FIG. 1 is a block diagram of a system incorporating the invention;

FIG. 2 is a schematic diagram illustrating the contents of the read only memory and the mass storage device;

FIG. 3 is a more detailed schematic view of the authentication program stored in the ROM and the game data stored in the mass storage unit;



FIG. 4 is a diagram illustrating the preparation of the game data set;

FIG. 5 is a diagram illustrating the authentication procedure for the game data set; and

FIG. 6 is a diagram illustrating an alternative approach to the secure loading of software into the system.

#### DETAILED DESCRIPTION OF THE PREFERRED EMBODIMENTS

Turning now to the drawings, FIG. 1 is a block diagram of an electronic casino gaming system incorporating the invention. As seen in this figure, the system consists of several system components under software control. These system components include a microprocessor 12, which may comprise any general purpose microprocessor, such as a Pentium-based microprocessor from Intel Corporation. A main memory unit 13 is provided, which is typically a random access memory having a capacity of between 32 and 64 megabytes for storing the majority of programs and graphics elements during game play. A system boot ROM 14 provides the initialization software required when power is first applied to the system. ROM 14 contains additional programs in read only form, including the operating system, related drivers and the authentication software described in detail below. A non-volatile RAM 17 is a battery backed static RAM capable of maintaining its contents through power cycle. NV RAM 17 stores significant information relating to game play, such as the number of player credits, the last game outcome and certain diagnostic and error information not critical to an understanding of the invention.

A mass storage unit implemented in the FIG. 1 system as a magnetic hard disk drive unit 18 is coupled to and controlled by a disk subsystem 19 of conventional design and operation. Disk drive unit 18 provides storage for the game specific data set, which includes both program data and image data specifying the rules of the various different casino games or single casino game variations, and the types of images and image sequences to be displayed to the game players. The size of the disk drive unit 18 is a function of the number of games and game variations provided for a given system, as well as the amount of data required for each specific game. In general, the more motion video designed into a particular casino game, the more storage required for that casino game software. A disk drive unit 18 with a 4-gigabyte capacity will usually provide sufficient storage capacity. Disk subsystem 19 comprises a disk controller connected to a PCI bus 20 for controlling the disk drive unit 18. Controller 19 preferably supports SCSI-2, with options of fast and wide. It should be noted that a number of different types of locally-based disk drive units may be used in the FIG. 1 system, including a CD-ROM storage unit. Also, the mass storage unit need not be physically located within the game console along with the other elements depicted in FIG. 1: the mass storage unit may be located remotely from the game console and coupled thereto by means of an appropriate network, such as an ethernet, an R5232 link, or some other hard-wired or wireless network link. This latter alternate arrangement is indicated by the inclusion of a network subsystem 21 of appropriate configuration and functional characteristics, which may have ethernet, R5232 serial, or other network compatibility.

A video subsystem 22 is coupled to the PCI bus and provides the capability of displaying full color still images and MPEG movies with a relatively high frame rate (e.g. 30 frames per second) on an appropriate monitor (not shown). Optional 3D texture mapping may be added to this system, if desired.

A sound subsystem 23 having a stereo sound playback capability with up to 16 bit CD quality sound is coupled to an ISA bus 24. A general purpose input/output unit 25 provides interfaces to the game mechanical devices (not illustrated) such as manually actuatable switches and display lights. A first bridge circuit 27 provides an interface between microprocessor 12, ROM 14, main memory 13 and PCI bus 20. Bridge circuit 27 is preferably a TRITON chip set available from INTEL Corporation. A second bridge circuit 28 provides an interface between the PCI bus 20 and the ISA bus 24. Bridge circuit 28 is preferably a type 82378 chip available from Intel Corporation.

FIG. 2 illustrates the types of information stored in the system ROM 14 and the mass storage unit. As seen in FIG. 2, the ROM unit 14 used in the FIG. 1 system comprises two separate ROM elements: ROM 29 and ROM 30. ROM 29 must be an unalterable device, such as a Toshiba type C53400 512Kx8 bit mask programmed ROM. ROM 30 is preferably an unalterable device like ROM 29, but may comprise a different type of ROM, such as a type 29FO40 field programmable flash ROM available from Intel Corp. ROM 29 contains the system initialization or boot code, an authentication program, a random number generator program and an initial portion of the executive/loader programs. ROM 30 contains the operating system program, the system drivers and the remainder of the executive/loader programs as noted below. The mass storage unit contains the applications, which include the game image and sound data, rules of game play and the like, and the signature associated to each particular casino game.

FIG. 3 illustrates the authentication and application program information in more detail. As seen in this figure, the authentication program stored in unalterable ROM 29 comprises a message digest algorithm component 32, a decryption algorithm component 33, and a decryption key component 34. The message digest algorithm component 32 stored in ROM 29 comprises an exact copy of a hash function program routine used to originally compute a message digest from the loadable game data set 36 in the manner described below. The decryption algorithm component 33 stored in ROM 29 comprises the algorithm required to decrypt any encrypted casino game data set signature using the decryption key component 34.

The decryption key component 34 comprises the decryption key that is required to decrypt any of the encrypted signatures 37 in the manner described below during the authentication routine.

FIG. 4 illustrates the manner in which an encrypted data set signature 37 is generated. A loadable casino game data set 36 is processed using a hash function 41 to generate a message digest 42 which is unique to the loadable game data set 36. The hash function employed may be one of a number of known hash functions, such as the MD2, MD4, and MD5 hash functions and the SHS hash function; or any other suitable hash function capable of producing a unique abbreviated bit string from a variable size input data set. For further information about these hash functions, reference should be had to the publication entitled "Answers To Frequently Asked Questions About Today's Cryptography", Revision 2.0, Oct. 5, 1993, published by RSA Laboratories, Redwood City, Calif., and the publications listed in the references section thereof, the disclosures of which are hereby incorporated by reference. After generation, the message digest 42 is then encrypted with an encryption algorithm 43 using a private encryption key 44 to generate a signature 37 of the message digest. In the preferred embodiment, the two-key (private/public key) encryption

technique developed by RSA Data Security, Inc. of Redwood City, Calif., is used. This technique is disclosed and described in U.S. Pat. Nos. 4,200,770, 4,218,582 and 4,405,829, the disclosures of which are hereby incorporated by reference. The signature **37** of the message digest **42** is then stored in the mass storage unit along with the loadable data set **36**.

FIG. 5 illustrates the authentication routine carried out in accordance with the invention, when the authentication routine is called (see below), the loadable casino game data set **36** is transferred from the mass storage unit to main memory **13** (unless already there), and the message digest of casino game data set **36** is computed using the message digest algorithm **32**. Message digest algorithm **32** uses the same hash function **41** as that used by the manufacturer to prepare the original message digest **42**. The result is an unencrypted version **46** of the message digest computed from the casino game data set **36** currently present in the mass storage unit. The encrypted data set signature **37** is decrypted using the public decryption key **34** matching the private key **44** used to originally encrypt the message digest **42** of the casino game data set **36**. The message digest **47** decrypted with decryption key **34** is then compared with the message digest **46** computed from the casino game data set **36**. If the two message digests match, then the casino game data set **36** is deemed authentic and game play may proceed. If there is no match, either the casino game data set **36** or the signature **37** is deemed corrupted and not authentic. Game play is prohibited and appropriate actions can be taken: e.g. alerting a security employee using a suitable messaging system (an audible alarm, flashing lights, or a network message from the game console to a central security area).

In order to ensure that the authentication routine cannot be bypassed by tampering with the loader program stored in ROM **30**, an initial part of the loader program is incorporated into unalterable ROM **29**. This initial portion of the loader program requires that the authentication program be called prior to the initiation of any casino game play. Since this initial portion of the loader program is located in the unalterable ROM **29**, and since no casino game play can occur until the particular casino game application data set **36** is loaded into main memory **13**, the authentication procedure cannot be bypassed by tampering with the software stored in ROM **30**.

Since authentication of the game data set **36** and signature **37** is entrusted to the contents of ROM **29**, a procedure must be provided to verify the ROM **29** contents. For this purpose, a message digest is computed for the authentication program stored in ROM **29**, and this message digest is stored in a secure manner with the casino operator or the gaming commission (or both) along with the hash function used to produce the message digest. This hash function may be the same hash function used to compute the message digest **42** of the casino game data set or a different hash function. In this way, the authenticity of the ROM **29** can be easily checked in the same way as that now performed in prior art devices; viz. computing the message digest directly from the ROM **29** and comparing the message digest thus computed with the custodial version of the message digest. If required by a given gaming commission or deemed desirable by a casino operator, the system may also display the message digest **42** of each particular data set **36** or the encrypted signature version **37** for auditing purposes. In addition, the system may transmit this information via networking subsystem **21** to an on-site or off-site remote location (such as the office of the gaming commission). The message digest displayed or transmitted may comprise the decrypted version or the computed version (or both).

The authentication procedure carried out by means of the message digest program **32**, decryption program **33** and decryption key **34** stored in unalterable ROM **29** in the manner described above is also used to authenticate the contents of all memory devices in the FIG. 1 system, such as the contents of ROM **30** (see FIG. 2), the fixed data portions and program components stored in NV RAM **17** and the program and fixed data contents of any memory devices stored in the networking subsystem **21**, video subsystem **22**, sound subsystem **23**, PCI-ISA interface **24**, and GPIO unit **25**. Each program or fixed data set stored in any memory device in any of these units has an associated signature, which is encrypted from a message digest of the original program or fixed data set using a hash function, which is preferably the same hash function used to prepare the message digest of the casino game data set. Prior to permitting any such program or fixed data set to participate in the system operation, that program or fixed data set is subjected to the authorization procedure to ensure that the message digest computed from the current version of the program or fixed data set matches the message digest decrypted from the encrypted signature associated to the program or fixed data set. In addition, the authentication procedure can be run on each such program or fixed data set at periodic or random intervals (on demand) in a manner essentially identical to that described above with respect to the casino game data set authentication procedure. As a consequence, the integrity of all software in the system is checked prior to the use of that particular software in order to reveal any unauthorized changes to the software portion of the casino gaming system.

An alternative approach to the secure loading of software into the system is depicted in FIG. 6. In this embodiment the basic input/output system (BIOS) software is stored in a ROM **50**, the first of two ROMs making up the system boot ROM **14** (FIG. 1). The boot strap code, operating system code (OS), OS drivers and a secure loader are stored in a second ROM **52**. An anchor application **54** including graphics and sound drivers, system drivers, money-handling software, a second secure loader, and a signature is stored in the mass storage **18** (FIG. 1).

When power is initially applied to the system on start-up, or when the system experiences a warm restart, the CPU **12** will begin executing code from the BIOS ROM **50**. The BIOS is responsible for initializing the motherboard and peripheral cards of the system. After the BIOS has completed the initialization, it jumps to the boot strap code in ROM **52** causing the boot strap to copy the OS, OS drivers, and the secure loader into RAM.

Once in RAM, the OS is started and the secure loader stored in ROM **52** is used to load the anchor application **54** from disk **18**. On disk, the anchor application has a signature that is used during the load to verify the validity of the anchor application.

After the anchor application **54** is started, it will be used to load all other applications. The secure loader of the anchor application will check the validity of an application to be loaded by computing the signature and comparing it against the one stored on disk with the application as described above.

An important advantage of the invention not found in prior art systems is the manner in which the casino game data set can be authenticated. In prior art systems, authentication of the casino game data set is normally only done when a payout lying above a given threshold is required by the outcome of the game play, and this requires that the game

be disabled while the ROM is physically removed and the ROM contents are verified. In systems incorporating the invention, the authenticity of a given casino game data set can be checked in a variety of ways. For example, the game data set **36** can be automatically subjected to the authentication procedure illustrated in FIG. **5** each time the game is loaded from the mass storage unit into the main memory **13**. Thus, as a player selects a casino game for game play in the system, the authenticity of that game actually stored in the mass storage unit is automatically checked using the authentication procedure described above without removing the ROM **29**. Further, if desired, the authentication procedure may be initiated in response to the pull of a slot game handle, the detection of a coin insert, the payout of coins or issuing of credit, or any other detectable event related to game play. The authenticity of a given casino game data set **36** can also be checked on demand, either locally at the game console or remotely via a network, by providing a demand procedure. Such a procedure may be initiated, e.g. by providing a manually operable switch in the game console, accessible only to authorized persons, for initiating the authentication routine. Alternatively, the FIG. **1** system may be configured to respond to a demand command generated remotely (e.g. in a security area in the casino or off-site) and transmitted to the game console over a network to the networking subsystem **21**.

Another advantage of the invention lies in the fact that the game data set storage capacity of a system incorporating the invention is not limited by the size of a ROM, but is rather dictated by the size of the mass storage unit. As a consequence, games using high resolution, high motion video and high quality stereo sound can be designed and played on systems incorporating the invention. Also, since the mass storage unit need not be a read-only device, and need not be physically located in the game console, the invention affords great flexibility in game content, scheduling and changes. For example, to change the graphic images in a particular casino game or set of games, new casino game data sets can be generated along with new signatures and stored in the mass storage unit by either exchanging disk drives, replacing disks (for read only disk units), or writing new data to the media. In the networked mass storage application, these changes can be made to the files controlled by the network file server. Since the casino game data sets must pass the authentication procedure test, either periodically or on demand, corrupted data sets cannot go undetected. Thus the invention opens up the field of electronic casino gaming systems to readily modifiable games with flexible displays and rules, without sacrificing the essential security of such systems. In fact, security is greatly enhanced by the ability of the invention to authenticate all game data sets both regularly (for each handle pull) and at any time (on demand), without interfering with regular game play (unless no match occurs between the two forms of message digest).

While the above provides a full and complete disclosure of the preferred embodiments of the invention, various modifications, alternate constructions and equivalents may be employed without departing from the true spirit and scope of the invention. For example, while the RSA public/private key encryption technique is preferred (due to the known advantages of this technique), a single, private key encryption technique may be employed, if desired. In a system using this technique, the single key would be stored in ROM **29** in place of the public key **34**. Also, the message digest **42** and signature **37** for a given application **36** need not be computed from the entire casino game data set. For

example, for some casino games it may be desirable to provide a fixed set of rules while permitting future changes in the casino game graphics, sound or both. For such casino games, it may be sufficient to compute the message digest **42** and signature **37** from only the rules portion of the applications program **36**. In other cases, it may be desirable or convenient to maintain the casino game video and audio portions constant, while allowing future changes to the rules of game play. For casino games of this category, the message digest **42** and signature **37** may be computed from the graphics and sound portions of the application program **36**. It may also be desirable to compute a message digest **42** and signature **37** from a subset of the rules, graphics or sound portions of a given applications program **36**, or from some other subset taken from a given applications program **36**. Therefore, the above should not be construed as limiting the scope of the invention, which is defined by the appended claims.

What is claimed is:

**[1.** An electronic gaming system for providing authentication of a data set associated with a casino type game, said system comprising:

- (a) a first storage means for storing a game data set and a game signature comprising an encrypted version of a unique primary abbreviated game bit string computed from said game data set;
- (b) a second storage means for storing,
  - an anchor application including a first authentication program capable of determining the validity of said game data set by,
  - computing a complementary abbreviated game bit string from said game data set,
  - decrypting said game signature set to recover said primary abbreviated game bit string,
  - comparing said complementary abbreviated game bit string with said primary abbreviated game bit string to determine whether a match is present, and
  - an anchor signature including an encrypted version of a unique primary abbreviated anchor bit string computed from said anchor application;
- (c) a third storage means for storing a second authentication program capable of determining the validity of said anchor application by,
  - computing a complementary abbreviated anchor bit string from said anchor application,
  - decrypting said anchor signature to recover said primary abbreviated anchor bit string, and
  - comparing said complementary abbreviated anchor bit string with said primary abbreviated anchor bit string to determine whether a match is present; and
- (d) processing means for enabling said first authentication program to determine the validity of said game data set and for enabling said second authentication program to determine the validity of said anchor application.]

**[2.** An electronic gaming system as recited in claim **1** further comprising a fourth storage means for storing basic input/output system (BIOS) code.]

**[3.** An electronic gaming system as recited in claim **2** wherein said fourth storage means is an unalterable ROM device.]

**[4.** An electronic gaming system as recited in claim **1** wherein said third storage means further stores operating system code, operating system drivers, and bootstrap code.]

**[5.** An electronic gaming system as recited in claim **1** wherein said first storage means and said second storage means comprise a single mass storage means.]

[6. An electronic gaming system as recited in claim 1 wherein said first storage means is a mass storage memory device.]

[7. An electronic gaming system as recited in claim 1 wherein said third storage means is an unalterable read only memory.]

[8. An electronic gaming system as recited in claim 1 wherein said first storage means is a CD ROM.]

[9. An electronic gaming system as recited in claim 1 wherein said first storage means is a hard disk drive.]

[10. An electronic gaming system as recited in claim 1 wherein said first storage means comprises a network storage system which is remote from the electronic gaming system.]

[11. An electronic gaming system as recited in claim 1 wherein said second storage means comprises a network storage system which is remote from the electronic gaming system.]

[12. An electronic gaming system as recited in claim 1 wherein said game data set is a game-modifying data set for changing game rules parameters of the casino type game.]

[13. An electronic gaming system as recited in claim 12 wherein said game-modifying data set includes a money handler modifying data set for changing money handling parameters of the casino type game.]

[14. An electronic gaming system as recited in claim 12 wherein said game-modifying data sets include a graphics modifying data set for changing graphics parameters of the casino type game.]

[15. An electronic gaming system as recited in claim 12 wherein said game-modifying data sets include a sound driver modifying data set for changing sound parameters of the casino type game.]

16. A casino gaming apparatus, comprising:

a casino game console;

a video display unit;

a main memory providing an executable space for a processor, said main memory being disposed in said casino game console;

a disk memory having gaming data relating to a casino game stored therein;

a nonvolatile memory operable to store gaming data at least related to the play of the casino game; and

a memory storing an operating system, said memory being disposed in said casino game console, wherein the operating system is enabled to control the disk memory and wherein the operating system is authenticated prior to the gaming data relating to the casino game;

the processor disposed in said casino game console and being operatively coupled to said video display unit, said main memory, said nonvolatile memory, said memory and said disk memory,

said processor operable to cause said gaming data stored in said disk memory to be transferred to said main memory,

said processor operable to cause said gaming data that was transferred from said disk memory to said main memory to be authenticated based on comparison of a message digest generated by performing a one-way hash function on said gaming data being authenticated with a message digest previously generated by performing a one-way hash function on known gaming data, each of said one-way hash functions producing a fixed-size string of bits, and

said processor causing a remedial action to be taken if said gaming data transferred from said disk memory to

said main memory is not authentic as determined by said processor.

17. The casino gaming apparatus as defined in claim 16 wherein the operating system is adapted for allowing access to files in a file system on the disk memory.

18. The casino gaming apparatus as defined in claim 16 wherein said disk memory comprises an optical disk.

19. The casino gaming apparatus as defined in claim 16 further comprising at least one peripheral device coupled to the gaming console, the peripheral device including a memory device wherein the processor is operable to authenticate contents of the memory device.

20. The casino gaming apparatus as defined in claim 16 wherein said disk memory comprises a magnetic hard disk.

21. The casino gaming apparatus as defined in claim 16 wherein said disk memory is operable as a read-only memory.

22. The casino gaming apparatus as defined in claim 16 wherein the disk memory is disposed in said casino game console.

23. The casino gaming apparatus as defined in claim 16 wherein the disk memory is disposed in a remote location separate from said casino game console.

24. The casino gaming apparatus as defined in claim 16 wherein the nonvolatile memory is disposed in said casino game console.

25. The casino gaming apparatus as defined in claim 16 wherein the nonvolatile memory is disposed in a remote location separate from said casino game console.

26. The casino gaming apparatus as defined in claim 16 wherein the video display unit is disposed in a remote location separate from said casino game console.

27. The casino gaming apparatus as defined in claim 16 further comprising a video subsystem, operatively coupled to the video display unit and operatively coupled to the processor, the video subsystem adapted for displaying still images, motion video or combinations thereof.

28. The casino gaming apparatus as defined in claim 16 wherein the processor is operable to generate a plurality of different casino games and wherein the plurality of different games are stored on the disk memory.

29. The casino gaming apparatus as defined in claim 16 wherein in response to receiving a selection of a first casino game from a plurality of different casino games, the casino gaming apparatus is operable to generate a play of the first casino game on the casino gaming apparatus.

30. The casino gaming apparatus as defined in claim 16 further comprising a sound-generating apparatus operatively coupled to the processor.

31. A casino gaming apparatus, comprising:

a casino game console;

a video display unit;

a main memory providing an executable space for a processor disposed in said casino game console;

a disk memory having gaming data relating to a casino game including program data and image data stored therein;

a memory storing software for controlling the disk memory wherein the software is authenticated prior to the gaming data related to the casino game; and

a nonvolatile memory operable to store gaming data at least related to the play of the casino game;

the processor disposed in said casino game console and being operatively coupled to said video display unit, said main memory, said memory, said nonvolatile memory and said disk memory, and

said processor operable to cause said gaming data to be authenticated based on a comparison of a first hash value generated from at least a portion of said gaming data relating to the casino game with a second hash value generated from known gaming data.

32. The casino gaming apparatus as defined in claim 31 further comprising a memory storing logic for an operating system.

33. The casino gaming apparatus as defined in claim 32 further comprising a secure loader adapted to control a loading of the portions of the gaming data related to the casino game from the disk memory.

34. The casino gaming apparatus as defined in claim 32 wherein the logic for the operating system is authenticated prior to loading the portions of the casino game from the disk memory.

35. The casino gaming apparatus as defined in claim 31 wherein the operating system is adapted for allowing access to files in a file system on the disk memory.

36. The casino gaming apparatus as defined in claim 31 wherein said disk memory comprises an optical disk.

37. The casino gaming apparatus as defined in claim 31 further comprising at least one peripheral device coupled to the gaming console including a memory device wherein the processor is operable to authenticate contents of the memory device.

38. The casino gaming apparatus as defined in claim 31 wherein said disk memory comprises a magnetic hard disk.

39. The casino gaming apparatus as defined in claim 31 wherein said disk memory is operable as a read-only memory.

40. The casino gaming apparatus as defined in claim 31 wherein the disk memory is disposed in said casino game console.

41. The casino gaming apparatus as defined in claim 31 wherein the disk memory is disposed in a remote location separate from said casino game console.

42. The casino gaming apparatus as defined in claim 31 wherein the nonvolatile memory is disposed in said casino game console.

43. The casino gaming apparatus as defined in claim 31 wherein the nonvolatile memory is disposed in a remote location separate from said casino game console.

44. The casino gaming apparatus as defined in claim 31 wherein the video display unit is disposed in a remote location separate from said casino game console.

45. The casino gaming apparatus as defined in claim 31 further comprising a video subsystem, operatively coupled to the video display unit and operatively coupled to the processor, adapted for displaying still images, motion video or combinations thereof.

46. The casino gaming apparatus as defined in claim 31 wherein the processor is operable to generate a plurality of different casino games and wherein the plurality of different games are stored on the disk memory.

47. The casino gaming apparatus as defined in claim 31 wherein in response to receiving a selection of a first casino game from a plurality of different casino games, the casino gaming apparatus is operable to generate a play of the first casino game on the casino gaming apparatus.

48. The casino gaming apparatus as defined in claim 31 further comprising a sound-generating apparatus operatively coupled to the processor.

49. A casino gaming apparatus, comprising:

a casino game console;

a video display unit;

a main memory providing an executable space for a processor, said main memory being disposed in said casino game console;

a disk memory, said disk memory having gaming data relating to a casino game stored therein; and

a memory storing system logic for reading files in a file system on the disk memory wherein the system logic is authenticated prior to authenticating the gaming data, said memory being disposed in said casino game console;

the processor disposed in said casino game console and being operatively coupled to said video display unit, said main memory, said memory and said disk memory, said processor operable to cause said gaming data to be authenticated based on a comparison of data generated by said processor from a hash function applied to said gaming data with data generated from the hash function applied to known gaming data, and

said processor operable to cause a remedial action to be taken based on an outcome of said authentication of said gaming data.

50. The casino gaming apparatus as defined in claim 49 wherein the memory is an unalterable memory separate from the main memory and separate from the disk the memory.

51. The casino gaming apparatus as defined in claim 49 wherein the memory is an alterable memory separate from the main memory and separate from the disk memory.

52. The casino gaming apparatus as defined in claim 49 wherein the processor is operable to cause information related to the authentication to be transferred to a remote storage device.

53. The casino gaming apparatus as defined in claim 49 wherein the system logic is a function of an operating system.

54. The casino gaming apparatus as defined in claim 49 further comprising a first memory storing a secure loader for loading the system logic.

55. The casino gaming apparatus as defined in claim 49 wherein said disk memory comprises an optical disk.

56. The casino gaming apparatus as defined in claim 49 further comprising at least one peripheral device coupled to the gaming console including a memory device wherein the processor is operable to authenticate contents of the memory device.

57. The casino gaming apparatus as defined in claim 49 wherein said disk memory comprises a magnetic hard disk.

58. The casino gaming apparatus as defined in claim 49 wherein said disk memory is operable as a read-only memory.

59. The casino gaming apparatus as defined in claim 49 wherein the disk memory is disposed in said casino game console.

60. The casino gaming apparatus as defined in claim 49 wherein the disk memory is disposed in a remote location separate from said casino game console.

61. The casino gaming apparatus as defined in claim 49 wherein the video display unit is disposed in a remote location separate from said casino game console.

62. The casino gaming apparatus as defined in claim 49 further comprising a video subsystem, operatively coupled to the video display unit and operatively coupled to the processor, adapted for displaying still images, motion video or combinations thereof.

63. The casino gaming apparatus as defined in claim 49 wherein the processor is operable to generate a plurality of different casino games and wherein the plurality of different games are stored on the disk memory.

64. The casino gaming apparatus as defined in claim 49 wherein in response to receiving a selection of a first casino

game from a plurality of different casino games, the casino gaming apparatus is operable to generate a play of the first casino game on the casino gaming apparatus.

65. The casino gaming apparatus as defined in claim 49 further comprising a sound-generating apparatus operatively coupled to the processor.

66. The casino gaming apparatus as defined in claim 49 further comprising a nonvolatile memory operable to store gaming data at least related to the play of the casino game.

67. The casino gaming apparatus as defined in claim 66 wherein the nonvolatile memory is disposed in said casino game console.

68. The casino gaming apparatus as defined in claim 66 wherein the nonvolatile memory is disposed in a remote location separate from said casino game console.

69. A casino gaming apparatus comprising:

a casino game console;

a video display unit;

a main memory providing an executable space for a processor being disposed in said casino game console;

a disk memory having gaming data relating to a casino game stored therein;

a memory storing an operating system adapted to control the disk memory wherein the operating system is authenticated prior to an authentication of the gaming data; and

at least one peripheral device coupled to the casino game console wherein the peripheral device includes a memory device for storing a fixed data set, a program or combinations thereof and wherein prior to allowing the program or the fixed data set to participate in system operations on the casino gaming apparatus, the casino gaming apparatus is operable to authenticate the fixed data set, the program or the combinations stored on the peripheral device;

the processor disposed in said casino game console and being operatively coupled to said video display unit, said main memory, said memory, the peripheral device and said disk memory,

said processor operable to cause said gaming data, the fixed data or the program to be checked based on a comparison of information generated from said gaming data, the fixed data or the program with previously generated data, and

said processor causing a remedial action to be taken based on an outcome of said checking of said gaming data, the fixed data or the program.

70. The casino gaming apparatus as defined in claim 69 wherein the at least one peripheral device is selected from the group consisting of a NV-RAM device, a sound system device, a video subsystem device, a money handling device, a general purpose input/output (GPIO) interface, a network interface device, a video display, a disk controller, display lights and a manually actuable switch.

71. The casino gaming apparatus as defined in claim 69 further comprising a network interface coupled to the casino game console for connecting to a network.

72. The casino gaming apparatus as defined in claim 71 wherein the network includes wireless links or wired links.

73. The casino gaming apparatus as defined in claim 71 wherein the casino gaming apparatus is operable to send gaming information via the network interface to a remote device controlled by a regulatory body.

74. The casino gaming apparatus as defined in claim 69 wherein the casino gaming apparatus is operable to transfer the gaming data relating to the casino game from a remote storage unit connected to the gaming apparatus via a network to a memory location disposed on the gaming console.

75. The casino gaming apparatus as defined in claim 69 wherein said processor utilizes decryption in checking said gaming data.

76. The casino gaming apparatus as defined in claim 69 wherein said disk memory comprises an optical disk.

77. The casino gaming apparatus as defined in claim 69 wherein said disk memory comprises a magnetic hard disk.

78. The casino gaming apparatus as defined in claim 69 wherein said disk memory is operable as a read-only memory.

79. The casino gaming apparatus as defined in claim 69 wherein the disk memory is disposed in said casino game console.

80. The casino gaming apparatus as defined in claim 69 wherein the disk memory is disposed in a remote location separate from said casino game console.

81. The casino gaming apparatus as defined in claim 69 wherein the video display unit is disposed in a remote location separate from said casino game console.

82. The casino gaming apparatus as defined in claim 69 further comprising a video subsystem, operatively coupled to the video display unit and operatively coupled to the processor, said video subsystem adapted for displaying still images, motion video or combinations thereof.

83. The casino gaming apparatus as defined in claim 69 wherein the processor is operable to generate a plurality of different casino games and wherein the plurality of different games are stored on the disk memory.

84. The casino gaming apparatus as defined in claim 69 wherein in response to receiving a selection of a first casino game from a plurality of different casino games, the casino gaming apparatus is operable to generate a play of the first casino game on the casino gaming apparatus.

85. The casino gaming apparatus as defined in claim 69 further comprising a sound-generating apparatus operatively coupled to the processor.

86. The casino gaming apparatus as defined in claim 69 further comprising a nonvolatile memory operable to store gaming data at least related to the play of the casino game.

87. The casino gaming apparatus as defined in claim 86 wherein the nonvolatile memory is disposed in said casino game console.

88. The casino gaming apparatus as defined in claim 86 wherein the nonvolatile memory is disposed in a remote location separate from said casino game console.

UNITED STATES PATENT AND TRADEMARK OFFICE  
**CERTIFICATE OF CORRECTION**

PATENT NO. : RE39,368 C1  
APPLICATION NO. : 90/008866  
DATED : June 16, 2009  
INVENTOR(S) : Allan E. Alcorn et al.

Page 1 of 1

It is certified that error appears in the above-identified patent and that said Letters Patent is hereby corrected as shown below:

On the title page, the assignee (item 73) "Silicon Gaming, Inc., Palo Alto, CA (US)" should be changed to --IGT, Reno, NV (US)--.

In col. 1, lines 28-29 (claim 16), insert a --,-- in between "processor" and "said".

Col. 1, lines 41-42 (claim 16); col. 2, lines 25-26 (claim 31); and col. 2, lines 54-55 (claim 49) should be **bolded**.

In col. 2, line 9 (claim 19); col. 2, line 38 (claim 37); col. 3, line 6 (claim 56); and col. 3, line 17 (claim 74), the text "casino game" should be **bolded**.

In col. 2, line 34 (claim 31), insert --a-- between "to" and "casino".

In col. 4, line 25 (claim 107); col. 5, line 49 (claim 120); col. 7, line 5 (claim 132); col. 8, line 31 (claim 145); and col. 9, line 58 (claim 158), insert --,-- between "processor" and "said".

In col. 7, line 46 (claim 134), insert --the-- between "to" and "authentication".

In col. 8, line 20 (claim 143), "plurlaity" should be replaced with --plurality--.

In col. 11, line 35 (claim 171); col. 12, line 43 (claim 184); col. 13, line 50 (claim 196); col. 14, line 61 (claim 209); and col. 16, line 4 (claim 222), --a-- should be inserted between "to" and "casino".

In col. 12, line 64 (claim 189), "loaded" should be replaced with --loader--.

In col. 16, line 53 (claim 233), "generated" should be replaced with --generate--.

Signed and Sealed this  
Seventeenth Day of April, 2012



David J. Kappos  
Director of the United States Patent and Trademark Office

UNITED STATES PATENT AND TRADEMARK OFFICE  
**CERTIFICATE OF CORRECTION**

PATENT NO. : RE39,368 E  
APPLICATION NO. : 90/008866  
DATED : June 16, 2009  
INVENTOR(S) : Allan E. Alcorn et al.

Page 1 of 1

It is certified that error appears in the above-identified patent and that said Letters Patent is hereby corrected as shown below:

On the title page, the assignee (item 73) "Silicon Gaming, Inc., Palo Alto, CA (US)" should be changed to --IGT, Reno, NV (US)--.

In col. 1, lines 28-29 (claim 16), insert a --,-- in between "processor" and "said".

Col. 1, lines 41-42 (claim 16); col. 2, lines 25-26 (claim 31); and col. 2, lines 54-55 (claim 49) should be **bolded**.

In col. 2, line 9 (claim 19); col. 2, line 38 (claim 37); col. 3, line 6 (claim 56); and col. 3, line 17 (claim 74), the text "casino game" should be **bolded**.

In col. 2, line 34 (claim 31), insert --a-- between "to" and "casino".

In col. 4, line 25 (claim 107); col. 5, line 49 (claim 120); col. 7, line 5 (claim 132); col. 8, line 31 (claim 145); and col. 9, line 58 (claim 158), insert --,-- between "processor" and "said".

In col. 7, line 46 (claim 134), insert --the-- between "to" and "authentication".

In col. 8, line 20 (claim 143), "plurlaity" should be replaced with --plurality--.

In col. 11, line 35 (claim 171); col. 12, line 43 (claim 184); col. 13, line 50 (claim 196); col. 14, line 61 (claim 209); and col. 16, line 4 (claim 222), --a-- should be inserted between "to" and "casino".

In col. 12, line 64 (claim 189), "loaded" should be replaced with --loader--.

In col. 16, line 53 (claim 233), "generated" should be replaced with --generate--.

This certificate supersedes the Certificate of Correction issued April 17, 2012.

Signed and Sealed this  
Sixteenth Day of October, 2012

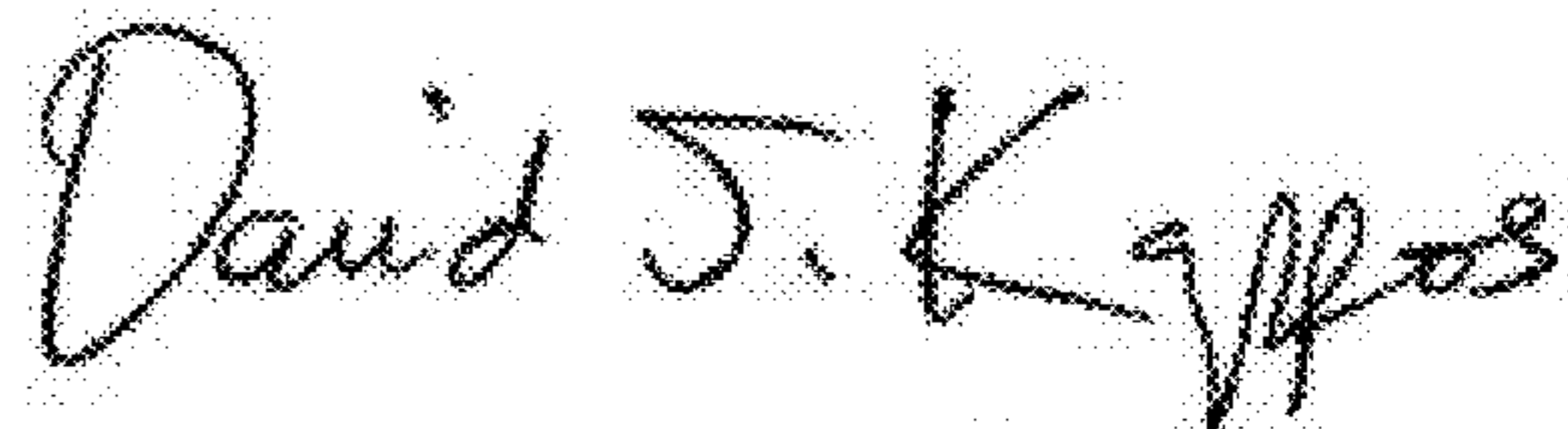

David J. Kappos  
Director of the United States Patent and Trademark Office





US00RE39368F1

(12) **EX PARTE REEXAMINATION CERTIFICATE** (6874th)  
**United States Patent**  
**Alcorn et al.**

(10) **Number:** **US RE39,368 F1**  
(45) **Certificate Issued:** **Jun. 16, 2009**

(54) **ELECTRONIC CASINO GAMING SYSTEM WITH IMPROVED PLAY CAPACITY, AUTHENTICATION AND SECURITY**

(51) **Int. Cl.**  
*A63F 13/00* (2006.01)  
*G06F 5/00* (2006.01)

(75) Inventors: **Allan E. Alcorn**, Portola Valley, CA (US); **Michael Barnett**, San Carlos, CA (US); **Louis D. Giacalone, Jr.**, Henderson, NV (US); **Adam E. Levinthal**, Redwood City, CA (US)

(52) **U.S. Cl.** ..... **463/29**  
(58) **Field of Classification Search** ..... None  
See application file for complete search history.

(73) Assignee: **Silicon Gaming, Inc.**, Palo Alto, CA (US)

(56) **References Cited**

U.S. PATENT DOCUMENTS

3,825,905 A 7/1974 Allen, Jr.  
3,838,264 A 9/1974 Maker  
4,193,131 A 3/1980 Lennon et al.  
4,200,770 A 4/1980 Hellman et al.

(Continued)

FOREIGN PATENT DOCUMENTS

EP 0 685 246 12/1995

(Continued)

OTHER PUBLICATIONS

Davida, G. et al., "Defending Systems Against Viruses through Cryptographic Authentication," Proceedings of the Symposium on Security and Privacy, *IEEE Com. Soc. Press*, pp. 312-318 (May 1-3, 1989) XP000041247.

(Continued)

*Primary Examiner*—Peter C. English

(57) **ABSTRACT**

The electronic casino gaming system consists of several system components, including a microprocessor (12), a main memory unit (13) that is typically a random access memory, and a system boot ROM (14). Also included in the electronic casino gaming system are a non-volatile RAM (17), a mass storage unit (18), a disk subsystem (19), and a PCI bus (20). The disk subsystem (19) preferably supports SCSI-2 with options of fast and wide. A video subsystem (22) is also included in the electronic casino gaming system and is coupled to the PCI bus (20) to provide full color still images and MPEG movies.

**Reexamination Request:**

No. 90/008,866, Dec. 10, 2007

**Reexamination Certificate for:**

Patent No.: **Re. 39,368**  
Issued: **Oct. 31, 2006**  
Appl. No.: **10/224,680**  
Filed: **Aug. 21, 2002**

(22) PCT Filed: **Jun. 17, 1996**

(86) PCT No.: **PCT/US96/10463**

§ 371 (c)(1),  
(2), (4) Date: **Mar. 10, 1998**

(87) PCT Pub. No.: **WO97/01902**

PCT Pub. Date: **Jan. 16, 1997**

**Related U.S. Patent Documents**

Reissue of:

(64) Patent No.: **6,106,396**  
Issued: **Aug. 22, 2000**  
Appl. No.: **08/981,882**  
Filed: **Mar. 10, 1998**

**Related U.S. Application Data**

(63) Continuation-in-part of application No. 08/497,662, filed on Jun. 29, 1995, now Pat. No. 5,643,086.

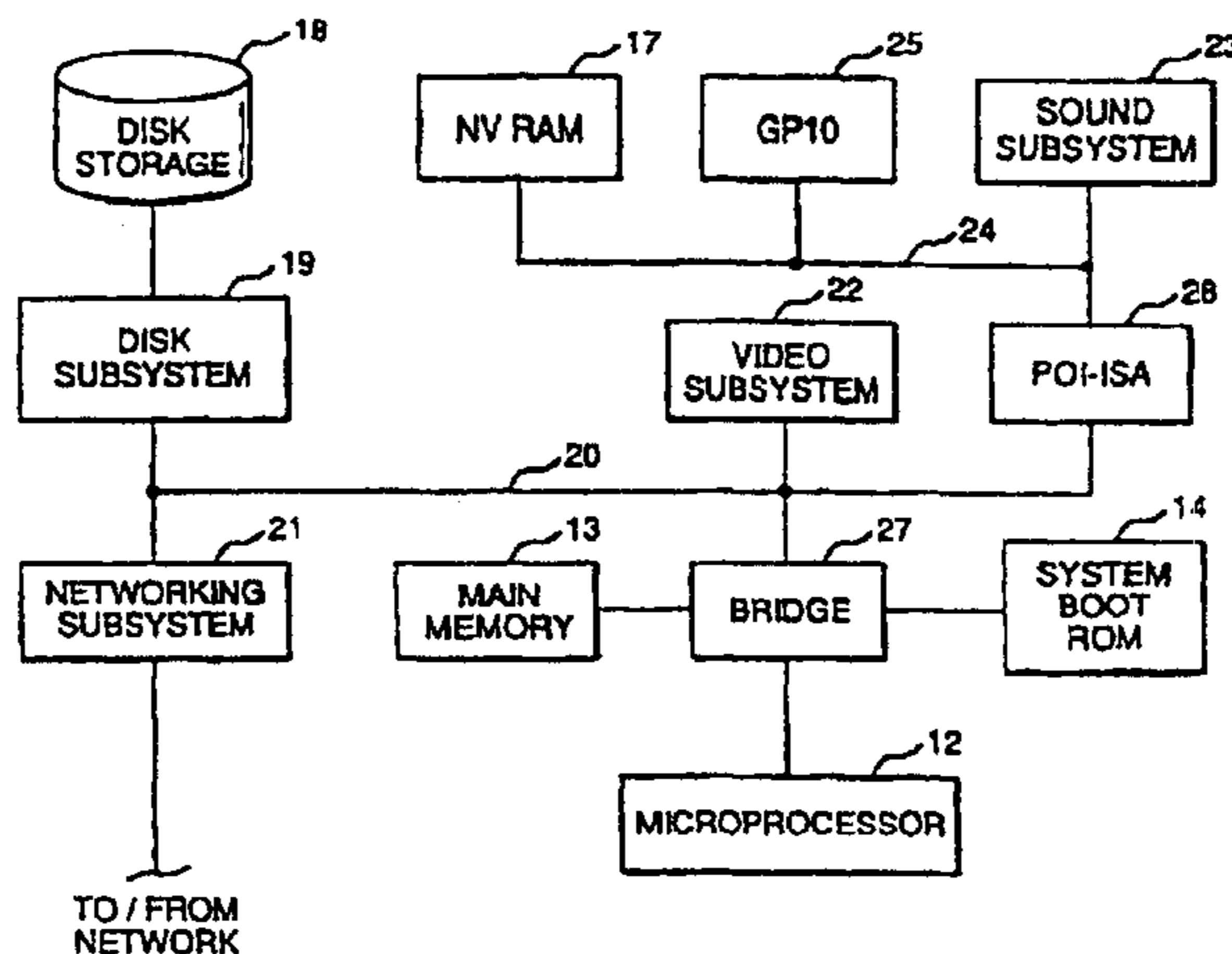

U.S. PATENT DOCUMENTS

4,218,582 A 8/1980 Hellman et al.  
 4,354,251 A 10/1982 Hellwig et al.  
 4,355,390 A 10/1982 Hellwig et al.  
 4,405,829 A 9/1983 Rivest et al.  
 4,458,315 A 7/1984 Uchenick  
 4,462,076 A 7/1984 Smith, III  
 4,467,424 A 8/1984 Hedges et al.  
 4,494,114 A 1/1985 Kaish  
 4,519,077 A 5/1985 Amin  
 4,525,599 A 6/1985 Curran et al.  
 4,582,324 A 4/1986 Koza et al.  
 4,607,844 A 8/1986 Fullerton  
 4,652,998 A \* 3/1987 Koza et al. .... 463/26  
 4,658,093 A 4/1987 Hellman  
 4,727,544 A 2/1988 Brunner et al.  
 4,752,068 A 6/1988 Endo  
 4,759,064 A 7/1988 Chaum  
 4,817,140 A 3/1989 Chandra et al.  
 4,837,728 A 6/1989 Barrie et al.  
 4,845,715 A 7/1989 Francisco  
 4,848,744 A 7/1989 Steininger et al.  
 4,856,787 A 8/1989 Itkis  
 4,865,321 A 9/1989 Nakagawa et al.  
 4,911,449 A 3/1990 Dickinson et al.  
 4,930,073 A 5/1990 Cina, Jr.  
 4,944,008 A 7/1990 Piosenka et al.  
 4,951,149 A 8/1990 Faroudja  
 5,004,232 A 4/1991 Wong et al.  
 5,021,772 A 6/1991 King et al.  
 5,050,212 A 9/1991 Dyson  
 5,103,081 A 4/1992 Fisher et al.  
 5,109,152 A 4/1992 Takagi et al.  
 5,146,575 A 9/1992 Nolan  
 5,155,680 A 10/1992 Wiedener  
 5,155,768 A 10/1992 Matsuhara  
 5,161,193 A 11/1992 Lampson et al.  
 5,179,517 A 1/1993 Sarbin et al.  
 5,224,160 A 6/1993 Paulini et al.  
 5,235,642 A 8/1993 Wobber et al.  
 5,259,613 A 11/1993 Marnell  
 5,283,734 A 2/1994 Von Kohorn  
 5,288,978 A 2/1994 Iijima  
 5,291,585 A 3/1994 Sato et al.  
 5,297,205 A 3/1994 Audebert et al.  
 5,326,104 A 7/1994 Pease et al.  
 5,342,047 A 8/1994 Heidel et al.  
 5,343,527 A 8/1994 Moore  
 5,398,932 A 3/1995 Eberhardt et al.  
 5,421,006 A 5/1995 Jablon et al.  
 5,465,364 A 11/1995 Lathrop et al.  
 5,488,702 A 1/1996 Byers et al.  
 5,489,095 A 2/1996 Goudard et al.  
 5,507,489 A 4/1996 Reibel et al.  
 5,586,766 A 12/1996 Forte et al.  
 5,586,937 A 12/1996 Menashe  
 5,604,801 A 2/1997 Dolan et al.  
 5,611,730 A 3/1997 Weiss  
 5,643,086 A 7/1997 Alcorn et al.  
 5,644,704 A 7/1997 Pease et al.  
 5,655,965 A 8/1997 Takemoto et al.  
 5,668,945 A 9/1997 Ohba et al.  
 5,704,835 A 1/1998 Dietz, II  
 5,707,286 A 1/1998 Carlson  
 5,725,428 A 3/1998 Achmuller

5,737,418 A 4/1998 Saffari et al.  
 5,742,616 A 4/1998 Torreiter et al.  
 5,759,102 A 6/1998 Pease et al.  
 5,768,382 A 6/1998 Schneier et al.  
 5,800,264 A 9/1998 Pascal et al.  
 5,934,672 A 8/1999 Sines et al.  
 5,991,399 A 11/1999 Graunke et al.  
 6,071,190 A 6/2000 Weiss et al.  
 6,104,815 A 8/2000 Alcorn et al.  
 6,106,396 A 8/2000 Alcorn et al.  
 6,149,522 A 11/2000 Alcorn et al.  
 6,195,587 B1 2/2001 Hruska et al.  
 6,620,047 B1 9/2003 Alcorn et al.  
 6,851,607 B2 2/2005 Orus et al.  
 2004/0002381 A1 1/2004 Alcorn et al.

FOREIGN PATENT DOCUMENTS

EP 1 352 677 10/2003  
 EP 1 441 464 7/2004  
 GB 2 121 569 12/1983  
 GB 2121569 12/1983  
 JP HEI 1-120654 5/1989  
 JP HEI 4-163627 6/1992  
 JP 6-327831 11/1994  
 JP 7-31737 2/1995  
 JP HEI 7-129207 5/1995  
 WO WO 99/65579 12/1999  
 WO WO 00/33196 6/2000

OTHER PUBLICATIONS

Document entitled "Fact Sheet on Digital Signature Standard" dated May 1994, 6 pages.  
 Federal Information Processing Standards (FIPS) Publication 180-1 entitled "Secure Hash Standard" dated Apr. 17, 1995, 2 title pages, abstract page and pp. 1-21.  
 Federal Information Processing Standards (FIPS) Publication 180 entitled "Secure Hash Standard" dated May 11, 1993, title page, abstract page and pp. 1-20.  
 Federal Information Processing Standards (FIPS) Publication 186 entitled "Digital Signature Standard (DSS)" dated May 19, 1994, 17 pages.  
 Hellman, Martin E., "The Mathematics of Public-Key Cryptography," *Scientific American*, vol. 241, No. 8, Aug. 1979, pp. 146-152 and 154-157.  
 Rivest, et al., "A Method for Obtaining Digital Signatures and Public-Key Cryptosystems," *Communications of the ACM*, vol. 21, No. 2, Feb. 1978, pp. 120-126.  
 Bakhtiari et al., *Cryptographic Hash Functions: A Survey*, 1995, Centre for Computer Security Research, pp. 1-26.  
 Bauspiess, et al., "Requirements For Cryptographic Hash Functions," *Computers and Security*, 5:427-437 (Sep. 11, 1992).  
*Casino Journal of Nevada*, Oct. 1996, pp. 64-66, 68-76, 78, 82, 84, 86, 88, 90,92, 94, 96, 98, 145 and 146.  
 Levinthal, et al., "The Silicon Gaming Odyssey Slot Machine," *IEEE* published Feb. 23, 1997, pp. 296-301.  
 Gasser, Morrie; Le Roux, Yves; Lipner, Steve, *The Digital Distributed System Security Architecture*, Securicom 90, Mar. 14-16, 1990, 8th Worldwide Congress on Computer and Communications Security and Protection.

\* cited by examiner

**1**  
**EX PARTE**  
**REEXAMINATION CERTIFICATE**  
**ISSUED UNDER 35 U.S.C. 307**

THE PATENT IS HEREBY AMENDED AS  
INDICATED BELOW.

Matter enclosed in heavy brackets [ ] appeared in the original patent, but was deleted by the reissue patent; matter printed in italics was added by the reissue patent. Matter enclosed in heavy double brackets [ [ ] appeared in the reissue patent but is deleted by this reexamination certificate; matter printed in boldface is added by this reexamination certificate.

AS A RESULT OF REEXAMINATION, IT HAS BEEN DETERMINED THAT:

The patentability of claims 69–73 and 75–85 is confirmed.

Claims 1–15 were previously cancelled.

Claims 16, 19, 31, 37, 49, 50, 56, 66, 74 and 86 are determined to be patentable as amended.

Claims 17, 18, 20–30, 32–36, 38–48, 51–55, 57–65, 67, 68, 87 and 88, dependent on an amended claim, are determined to be patentable.

New claims 89–312 are added and determined to be patentable.

16. *A casino gaming apparatus, comprising:*

*a casino game console,*

*a video display unit;*

*a main memory providing an executable space for a processor said main memory being disposed in said casino game console;*

*a disk memory having gaming data relating to a casino game stored therein;*

*a nonvolatile memory operable to store gaming data at least related to [ [the]] play of the casino game; [and]*

*a memory storing an operating system, said memory being disposed in said casino game console, wherein the operating system is enabled to control the disk memory and wherein the operating system is authenticated prior to the gaming data relating to the casino game;*

*a fifth memory, coupled to the processor, configured to store a boot code for the casino gaming apparatus; and the processor disposed in said casino game console and being operatively coupled to said video display unit, said main memory, said nonvolatile memory, said memory and said disk memory,*

*said processor operable to cause said gaming data stored in said disk memory to be transferred to said main memory,*

*said processor operable to cause said gaming data that was transferred from said disk memory to said main memory to be authenticated based on comparison of a message digest generated by performing a one-way hash function on said gaming data being authenticated with a message digest previously generated by performing a one-way hash function on known gaming data,*

**2**

*each of said one-way hash functions producing a fixed-size string of bits, and*

*said processor causing a remedial action to be taken if said gaming data transferred from said disk memory to said main memory is not authentic as determined by said processor.*

19. *The casino gaming apparatus as defined in claim 16 further comprising at least one peripheral device coupled to the [gaming] casino game console, the peripheral device including a memory device wherein the processor is operable to authenticate contents of the memory device.*

31. *A casino gaming apparatus, comprising:*

*a casino game console;*

*a video display unit;*

*a main memory providing an executable space for a processor disposed in said casino game console;*

*a disk memory having gaming data relating to a casino game including program data and image data stored therein;*

*a memory storing software for controlling the disk memory wherein the software is authenticated prior to the gaming data related to the casino game; [and]*

*a nonvolatile memory operable to store gaming data at least related to [the] play of the casino game;*

*a fifth memory, coupled to the processor, configured to store a boot code for the casino gaming apparatus; and*

*the processor disposed in said casino game console and being operatively coupled to said video display unit, said main memory, said memory, said nonvolatile memory and said disk memory, and*

*said processor operable to cause said gaming data to be authenticated based on a comparison of a first hash value generated from at least a portion of said gaming data relating to casino game with a second hash value generated from known gaming data.*

37. *The casino gaming apparatus as defined in claim 31 further comprising at least one peripheral device coupled to the [gaming] casino game console including a memory device wherein the processor is operable to authenticate contents of the memory device.*

49. *A casino gaming apparatus, comprising:*

*a casino game console;*

*a video display unit;*

*a main memory providing an executable space for a processor, said main memory being disposed in said casino game console,*

*a disk memory, said disk memory having gaming data relating to a casino game stored therein; [and]*

*a memory storing system logic for reading files in a file system on the disk memory wherein the system logic is authenticated prior to authenticating the gaming data, said memory being disposed in said casino game console;*

*a fourth memory, coupled to the processor, configured to store a boot code for the casino gaming apparatus; and the processor disposed in said casino game console and being operatively coupled to said video display unit, said main memory, said memory and said disk memory;*

*said processor operable to cause said gaming data to be authenticated based on a comparison of data generated by said processor from a hash function applied to said gaming data with data generated from the hash function applied to known gaming data, and*

*said processor operable to cause a remedial action to be taken based on an outcome of said authentication of said gaming data.*

50. The casino gaming apparatus as defined in claim 49 wherein the memory is an unalterable memory separate from the main memory and separate from the disk **[[the]]** memory.

56. The casino gaming apparatus as defined in claim 49 further comprising at least one peripheral device coupled to the **[[gaming]]** casino game console including a memory device wherein the processor is operable to authenticate contents of the memory device.

66. The casino gaming apparatus as defined in claim 49 further comprising a nonvolatile memory operable to store gaming data at least related to **[[the]]** play of the casino game.

74. The casino gaming apparatus as defined in claim 69 wherein the casino gaming apparatus is operable to transfer the gaming data relating to the casino game from a remote storage unit connected to the gaming apparatus via a network to a memory location disposed on the **[[gaming]]** casino game console.

86. The casino gaming apparatus as defined in claim 69 further comprising a nonvolatile memory operable to store gaming data at least related to **[[the]]** play of the casino game.

89. The casino gaming apparatus as defined in claim 16 wherein said processor is operable to send information relating to the authentication of the gaming data to a remote device.

90. The casino gaming apparatus as defined in claim 89 wherein said remote device is operated by a gaming regulator.

91. The casino gaming apparatus as defined in claim 16 wherein said processor is operable to display information relating to the authentication of the gaming data on the video display unit.

92. The casino gaming apparatus as defined in claim 16, wherein the memory and the fifth memory are located on a same memory device.

93. The casino gaming apparatus as defined in claim 16, wherein, in response to an event generated while the casino gaming apparatus is available for game play, at least a portion of the gaming data is authenticated.

94. The casino gaming apparatus as defined in claim 16, wherein at least a portion of the gaming data is authenticated while the casino gaming apparatus is available for game play.

95. The casino gaming apparatus as defined in claim 31 wherein said processor is operable to send information relating to the authentication of the gaming data to a remote device.

96. The casino gaming apparatus as defined in claim 95 wherein said remote device is operated by a gaming regulator.

97. The casino gaming apparatus as defined in claim 31 wherein said processor is operable to display information relating to the authentication of the gaming data on the video display unit.

98. The casino gaming apparatus as defined in claim 31, wherein the memory and the fifth memory are located on a same memory device.

99. The casino gaming apparatus as defined in claim 31, wherein, in response to an event generated while the casino gaming apparatus is available for game play, at least a portion of the gaming data is authenticated.

100. The casino gaming apparatus as defined in claim 31, wherein at least a portion of the gaming data is authenticated while the casino gaming apparatus is available for game play.

101. The casino gaming apparatus as defined in claim 49 wherein said processor is operable to send informa-

tion relating to the authentication of the gaming data to a remote device.

102. The casino gaming apparatus as defined in claim 101 wherein said remote device is operated by a gaming regulator.

103. The casino gaming apparatus as defined in claim 49 wherein said processor is operable to display information relating to the authentication of the gaming data to the video display unit.

104. The casino gaming apparatus as defined in claim 49, wherein the memory and the fourth memory are located on a same memory device.

105. The casino gaming apparatus as defined in claim 49, wherein, in response to an event generated while the casino gaming apparatus is available for game play, at least a portion of the gaming data is authenticated.

106. The casino gaming apparatus as defined in claim 49, wherein at least a portion of the gaming data is authenticated while the casino gaming apparatus is available for game play.

107. A casino gaming apparatus, comprising:

a casino game console,

a video display unit;

a main memory providing an executable space for a processor said main memory being disposed in said casino game console;

a disk memory having gaming data relating to a casino game stored therein;

a nonvolatile memory operable to store gaming data at least related to play of the casino game;

a memory storing an operating system, said memory being disposed in said casino game console, wherein the operating system is enabled to control the disk memory and wherein the operating system is authenticated prior to the gaming data relating to the casino game;

a fifth memory configured to store a random number generator program used for generating outcomes for the casino game wherein the random number generator program is stored and authenticated separately from the gaming data; and

the processor disposed in said casino game console and being operatively coupled to said video display unit, said main memory, said nonvolatile memory, said memory and said disk memory,

said processor operable to cause said gaming data stored in said disk memory to be transferred to said main memory,

said processor operable to cause said gaming data that was transferred from said disk memory to said main memory to be authenticated based on comparison of a message digest generated by performing a one-way hash function on said gaming data being authenticated with a message digest previously generated by performing a one-way hash function on known gaming data, each of said one-way hash functions producing a fixed-size string of bits, and

said processor causing a remedial action to be taken if said gaming data transferred from said disk memory to said main memory is not authentic as determined by said processor.

108. The casino gaming apparatus as defined in claim 107 wherein said processor is operable to send information relating to the authentication of the gaming data to a remote device.

109. The casino gaming apparatus as defined in claim 107 wherein said processor is operable to display information relating to the authentication of the gaming data on the video display unit.

110. The casino gaming apparatus as defined in claim 107, wherein the memory and the fifth memory are located on a same memory device.

111. The casino gaming apparatus as defined in claim 107, wherein, in response to an event generated while the casino gaming apparatus is available for game play, at least a portion of the gaming data is authenticated.

112. The casino gaming apparatus as defined in claim 107, wherein at least a portion of the gaming data is authenticated while the casino gaming apparatus is available for game play.

113. The casino gaming apparatus as defined in claim 107 wherein the operating system is adapted for allowing access to files in a file system on the disk memory.

114. The casino gaming apparatus as defined in claim 107 further comprising at least one peripheral device coupled to the casino game console including a memory device wherein the processor is operable to authenticate contents of the memory device.

115. The casino gaming apparatus as defined in claim 107 wherein the video display unit is disposed in a remote location separate from said casino game console.

116. The casino gaming apparatus as defined in claim 107 further comprising a video subsystem, operatively coupled to the video display unit and operatively coupled to the processor, adapted for displaying still images, motion video or combinations thereof.

117. The casino gaming apparatus as defined in claim 107 wherein the processor is operable to generate a plurality of different casino games and wherein the plurality of different games are stored on the disk memory.

118. The casino gaming apparatus as defined in claim 107 wherein in response to receiving a selection of a first casino game from a plurality of different casino games, the casino gaming apparatus is operable to generate a play of the first casino game on the casino gaming apparatus.

119. The casino gaming apparatus as defined in claim 107 further comprising a sound-generating apparatus operatively coupled to the processor.

120. A casino gaming apparatus, comprising:

a casino game console,

a video display unit;

a main memory providing an executable space for a processor said main memory being disposed in said casino game console;

a disk memory having gaming data relating to a casino game stored therein;

a nonvolatile memory operable to store gaming data at least related to play of the casino game;

a memory storing an operating system, said memory being disposed in said casino game console, wherein the operating system is enabled to control the disk memory and wherein the operating system is authenticated prior to the gaming data relating to the casino game;

wherein, in response to an event generated while the casino gaming apparatus is available for game play, at least a portion of the gaming data is authenticated; and

the processor disposed in said casino game console and being operatively coupled to said video display unit,

said main memory, said nonvolatile memory, said memory and said disk memory,

said processor operable to cause said gaming data stored in said disk memory to be transferred to said main memory,

said processor operable to cause said gaming data that was transferred from said disk memory to said main memory to be authenticated based on comparison of a message digest generated by performing a one-way hash function on said gaming data being authenticated with a message digest previously generated by performing a one-way hash function on known gaming data, each of said one-way hash functions producing a fixed-size string of bits, and

said processor causing a remedial action to be taken if said gaming data transferred from said disk memory to said main memory is not authentic as determined by said processor.

121. The casino gaming apparatus as defined in claim 120 wherein said processor is operable to send information relating to the authentication of the gaming data to a remote device.

122. The casino gaming apparatus as defined in claim 120 wherein said processor is operable to display information relating to the authentication of the gaming data on the video display unit.

123. The casino gaming apparatus as defined in claim 120, further comprising a fifth memory configured to store a random number generator program used for generating outcomes for the casino game wherein the random number generator program is stored and authenticated separately from the gaming data.

124. The casino gaming apparatus as defined in claim 120, further comprising a fifth memory, coupled to the processor, configured to store a boot code for the casino gaming apparatus.

125. The casino gaming apparatus as defined in claim 120 wherein the operating system is adapted for allowing access to files in a file system on the disk memory.

126. The casino gaming apparatus as defined in claim 120 further comprising at least one peripheral device coupled to the casino game console including a memory device wherein the processor is operable to authenticate contents of the memory device.

127. The casino gaming apparatus as defined in claim 120 wherein the video display unit is disposed in a remote location separate from said casino game console.

128. The casino gaming apparatus as defined in claim 120 further comprising a video subsystem, operatively coupled to the video display unit and operatively coupled to the processor, adapted for displaying still images, motion video or combinations thereof.

129. The casino gaming apparatus as defined in claim 120 wherein the processor is operable to generate a plurality of different casino games and wherein the plurality of different games are stored on the disk memory.

130. The casino gaming apparatus as defined in claim 120 wherein in response to receiving a selection of a first casino game from a plurality of different casino games, the casino gaming apparatus is operable to generate a play of the first casino game on the casino gaming apparatus.

131. The casino gaming apparatus as defined in claim 120 further comprising a sound-generating apparatus operatively coupled to the processor.

132. A casino gaming apparatus, comprising:

a casino game console,

a video display unit;

a main memory providing an executable space for a processor said main memory being disposed in said casino game console;

a disk memory having gaming data relating to a casino game stored therein;

a nonvolatile memory operable to store gaming data at least related to play of the casino game;

a memory storing an operating system, said memory being disposed in said casino game console, wherein the operating system is enabled to control the disk memory and wherein the operating system is authenticated prior to the gaming data relating to the casino game;

wherein at least a portion of the gaming data is authenticated while the casino gaming apparatus is available for game play; and

the processor disposed in said casino game console and being operatively coupled to said video display unit, said main memory, said nonvolatile memory, said memory and said disk memory,

said processor operable to cause said gaming data stored in said disk memory to be transferred to said main memory,

said processor operable to cause said gaming data that was transferred from said disk memory to said main memory to be authenticated based on comparison of a message digest generated by performing a one-way hash function on said gaming data being authenticated with a message digest previously generated by performing a one-way hash function on known gaming data, each of said one-way hash functions producing a fixed-size string of bits, and

said processor causing a remedial action to be taken if said gaming data transferred from said disk memory to said main memory is not authentic as determined by said processor.

133. The casino gaming apparatus as defined in claim 132 wherein said processor is operable to send information relating to the authentication of the gaming data to a remote device.

134. The casino gaming apparatus as defined in claim 132 wherein said processor is operable to display information relating to authentication of the gaming data on the video display unit.

135. The casino gaming apparatus as defined in claim 132, further comprising a fifth memory, coupled to the processor, configured to store a random number generator program used for generating outcomes for the casino game wherein the random number generator program is stored and authenticated separately from the gaming data.

136. The casino gaming apparatus as defined in claim 132, further comprising a fifth memory, coupled to the processor, configured to store a boot code for the casino gaming apparatus.

137. The casino gaming apparatus as defined in claim 132, wherein, in response to an event generated while the casino gaming apparatus is available for game play, at least a portion of the gaming data is authenticated.

138. The casino gaming apparatus as defined in claim 132 wherein the operating system is adapted for allowing access to files in a file system on the disk memory.

139. The casino gaming apparatus as defined in claim 132 further comprising at least one peripheral device coupled to the casino game console including a memory device wherein the processor is operable to authenticate contents of the memory device.

140. The casino gaming apparatus as defined in claim 132 wherein the video display unit is disposed in a remote location separate from said casino game console.

141. The casino gaming apparatus as defined in claim 132 further comprising a video subsystem, operatively coupled to the video display unit and operatively coupled to the processor, adapted for displaying still images, motion video or combinations thereof.

142. The casino gaming apparatus as defined in claim 132 wherein the processor is operable to generate a plurality of different casino games and wherein the plurality of different games are stored on the disk memory.

143. The casino gaming apparatus as defined in claim 132 wherein in response to receiving a selection of a first casino game from a plurality of different casino games, the casino gaming apparatus is operable to generate a play of the first casino game on the casino gaming apparatus.

144. The casino gaming apparatus as defined in claim 132 further comprising a sound-generating apparatus operatively coupled to the processor.

145. A casino gaming apparatus, comprising:

a casino game console;

a video display unit;

a main memory providing an executable space for a processor said main memory being disposed in said casino game console;

a disk memory having gaming data relating to a casino game stored therein;

a nonvolatile memory operable to store gaming data at least related to play of the casino game;

a memory storing an operating system, said memory being disposed in said casino game console, wherein the operating system is enabled to control the disk memory and wherein the operating system is authenticated prior to the gaming data relating to the casino game;

at least one peripheral device coupled to the casino game console including a memory device wherein the processor is operable to authenticate contents of the memory device; and

the processor disposed in said casino game console and being operatively coupled to said video display unit, said main memory, said nonvolatile memory, said memory and said disk memory,

said processor operable to cause said gaming data stored in said disk memory to be transferred to said main memory,

said processor operable to cause said gaming data that was transferred from said disk memory to said main memory to be authenticated based on comparison of a message digest generated by performing a one-way hash function on said gaming data being authenticated with a message digest previously generated by performing a one-way hash function on known gaming data, each of said one-way hash functions producing a fixed-size string of bits, and

said processor causing a remedial action to be taken if said gaming data transferred from said disk memory to said main memory is not authentic as determined by said processor.

146. The casino gaming apparatus as defined in claim 145 wherein said processor is operable to send information relating to the authentication of the gaming data to a remote device.

147. The casino gaming apparatus as defined in claim 145 wherein said processor is operable to display information relating to the authentication of the gaming data on the video display unit.

148. The casino gaming apparatus as defined in claim 145, further comprising a fifth memory, coupled to the processor, configured to store a random number generator program used for generating outcomes for the casino game wherein the random number generator program is stored and authenticated separately from the gaming data.

149. The casino gaming apparatus as defined in claim 145, further comprising a fifth memory, coupled to the processor, configured to store a boot code for the casino gaming apparatus.

150. The casino gaming apparatus as defined in claim 145, wherein, in response to an event generated while the casino gaming apparatus is available for game play, at least a portion of the gaming data is authenticated.

151. The casino gaming apparatus as defined in claim 145 wherein the operating system is adapted for allowing access to files in a file system on the disk memory.

152. The casino gaming apparatus as defined in claim 145 wherein at least a portion of the gaming data is authenticated while the casino gaming apparatus is available for game play.

153. The casino gaming apparatus as defined in claim 145 wherein the video display unit is disposed in a remote location separate from said casino game console.

154. The casino gaming apparatus as defined in claim 145 further comprising a video subsystem, operatively coupled to the video display unit and operatively coupled to the processor, adapted for displaying still images, motion video or combinations thereof.

155. The casino gaming apparatus as defined in claim 145 wherein the processor is operable to generate a plurality of different casino games and wherein the plurality of different games are stored on the disk memory.

156. The casino gaming apparatus as defined in claim 145 wherein in response to receiving a selection of a first casino game from a plurality of different casino games, the casino gaming apparatus is operable to generate a play of the first casino game on the casino gaming apparatus.

157. The casino gaming apparatus as defined in claim 145 further comprising a sound-generating apparatus operatively coupled to the processor.

158. A casino gaming apparatus, comprising:

a casino game console,

a video display unit wherein the video display unit is disposed in a remote location separate from said casino game console;

a main memory providing an executable space for a processor said main memory being disposed in said casino game console;

a disk memory having gaming data relating to a casino game stored therein;

a nonvolatile memory operable to store gaming data at least related to play of the casino game;

a memory storing an operating system, said memory being disposed in said casino game console, wherein the operating system is enabled to control the disk

memory and wherein the operating system is authenticated prior to the gaming data relating to the casino game; and

the processor disposed in said casino game console and being operatively coupled to said video display unit, said main memory, said nonvolatile memory, said memory and said disk memory,

said processor operable to cause said gaming data stored in said disk memory to be transferred to said main memory,

said processor operable to cause said gaming data that was transferred from said disk memory to said main memory to be authenticated based on comparison of a message digest generated by performing a one-way hash function on said gaming data being authenticated with a message digest previously generated by performing a one-way hash function on known gaming data, each of said one-way hash functions producing a fixed-size string of bits, and

said processor causing a remedial action to be taken if said gaming data transferred from said disk memory to said main memory is not authentic as determined by said processor.

159. The casino gaming apparatus as defined in claim 158 wherein said processor is operable to send information relating to the authentication of the gaming data to a remote device.

160. The casino gaming apparatus as defined in claim 158 wherein said processor is operable to display information relating to the authentication of the gaming data on the video display unit.

161. The casino gaming apparatus as defined in claim 158, further comprising a fifth memory, coupled to the processor, configured to store a random number generator program used for generating outcomes for the casino game wherein the random number generator program is stored and authenticated separately from the gaming data.

162. The casino gaming apparatus as defined in claim 158, further comprising a fifth memory, coupled to the processor, configured to store a boot code for the casino gaming apparatus.

163. The casino gaming apparatus as defined in claim 158, wherein, in response to an event generated while the casino gaming apparatus is available for game play, at least a portion of the gaming data is authenticated.

164. The casino gaming apparatus as defined in claim 158 wherein the operating system is adapted for allowing access to files in a file system on the disk memory.

165. The casino gaming apparatus as defined in claim 158 wherein at least a portion of the gaming data is authenticated while the casino gaming apparatus is available for game play.

166. The casino gaming apparatus as defined in claim 158 further comprising at least one peripheral device coupled to the casino game console including a memory device wherein the processor is operable to authenticate contents of the memory device.

167. The casino gaming apparatus as defined in claim 158 further comprising a video subsystem, operatively coupled to the video display unit and operatively coupled to the processor, adapted for displaying still images, motion video or combinations thereof.

168. The casino gaming apparatus as defined in claim 158 wherein the processor is operable to generate a plurality of different casino games and wherein the plurality of different games are stored on the disk memory.

169. The casino gaming apparatus as defined in claim 158 wherein in response to receiving a selection of a first casino game from a plurality of different casino games, the casino gaming apparatus is operable to generate a play of the first casino game on the casino gaming apparatus.

170. The casino gaming apparatus as defined in claim 158 further comprising a sound-generating apparatus operatively coupled to the processor.

171. A casino gaming apparatus, comprising:

a casino game console;

a video display unit;

a main memory providing an executable space for a processor disposed in said casino game console;

a disk memory having gaming data relating to a casino game including program data and image data stored therein;

a memory storing software for controlling the disk memory wherein the software is authenticated prior to the gaming data related to the casino game;

a nonvolatile memory operable to store gaming data at least related to play of the casino game;

a fifth memory configured to store a random number generator program used for generating outcomes for the casino game wherein the random number generator program is stored and authenticated separately from the gaming data; and

the processor disposed in said casino game console and being operatively coupled to said video display unit, said main memory, said memory, said nonvolatile memory and said disk memory,

said processor operable to cause said gaming data to be authenticated based on a comparison of a first hash value generated from at least a portion of said gaming data relating to casino game with a second hash value generated from known gaming data.

172. The casino gaming apparatus as defined in claim 171 wherein said processor is operable to send information relating to the authentication of the gaming data to a remote device.

173. The casino gaming apparatus as defined in claim 171 wherein said processor is operable to display information relating to the authentication of the gaming data on the video display unit.

174. The casino gaming apparatus as defined in claim 171, wherein the memory and the fifth memory are located on a same memory device.

175. The casino gaming apparatus as defined in claim 171, wherein, in response to an event generated while the casino gaming apparatus is available for game play, at least a portion of the gaming data is authenticated.

176. The casino gaming apparatus as defined in claim 171, wherein at least a portion of the gaming data is authenticated while the casino gaming apparatus is available for game play.

177. The casino gaming apparatus as defined in claim 171 further comprising a secure loader adapted to control a loading of the portions of the gaming data related to the casino game from the disk memory.

178. The casino gaming apparatus as defined in claim 171 further comprising at least one peripheral device coupled to the casino game console including a memory device wherein the processor is operable to authenticate contents of the memory device.

179. The casino gaming apparatus as defined in claim 171 wherein the video display unit is disposed in a remote location separate from said casino game console.

180. The casino gaming apparatus as defined in claim 171 further comprising a video subsystem, operatively coupled to the video display unit and operatively coupled to the processor, adapted for displaying still images, motion video or combinations thereof.

181. The casino gaming apparatus as defined in claim 171 wherein the processor is operable to generate a plurality of different casino games and wherein the plurality of different games are stored on the disk memory.

182. The casino gaming apparatus as defined in claim 171 wherein in response to receiving a selection of a first casino game from a plurality of different casino games, the casino gaming apparatus is operable to generate a play of the first casino game on the casino gaming apparatus.

183. The casino gaming apparatus as defined in claim 171 further comprising a sound-generating apparatus operatively coupled to the processor.

184. A casino gaming apparatus, comprising:

a casino game console;

a video display unit;

a main memory providing an executable space for a processor disposed in said casino game console;

a disk memory having gaming data relating to a casino game including program data and image data stored therein;

a memory storing software for controlling the disk memory wherein the software is authenticated prior to the gaming data related to the casino game;

a nonvolatile memory operable to store gaming data at least related to play of the casino game;

wherein, in response to an event generated while the casino gaming apparatus is available for game play, at least a portion of the gaming data is authenticated; and

the processor disposed in said casino game console and being operatively coupled to said video display unit, said main memory, said memory, said nonvolatile memory and said disk memory,

said processor operable to cause said gaming data to be authenticated based on a comparison of a first hash value generated from at least a portion of said gaming data relating to casino game with a second hash value generated from known gaming data.

185. The casino gaming apparatus as defined in claim 184 wherein said processor is operable to send information relating to the authentication of the gaming data to a remote device.

186. The casino gaming apparatus as defined in claim 184 wherein said processor is operable to display information relating to the authentication of the gaming data on the video display unit.

187. The casino gaming apparatus as defined in claim 184, further comprising a fifth memory configured to store a random number generator program used for generating outcomes for the casino game wherein the random number generator program is stored and authenticated separately from the gaming data.

188. The casino gaming apparatus as defined in claim 184, further comprising a fifth memory, coupled to the processor, configured to store a boot code for the casino gaming apparatus.

189. The casino gaming apparatus as defined in claim 184 further comprising a secure loader adapted to control a loading of the portions of the gaming data related to the casino game from the disk memory.



190. The casino gaming apparatus as defined in claim 184 further comprising at least one peripheral device coupled to the casino game console including a memory device wherein the processor is operable to authenticate contents of the memory device.

191. The casino gaming apparatus as defined in claim 184 wherein the video display unit is disposed in a remote location separate from said casino game console.

192. The casino gaming apparatus as defined in claim 184 further comprising a video subsystem, operatively coupled to the video display unit and operatively coupled to the processor, adapted for displaying still images, motion video or combinations thereof.

193. The casino gaming apparatus as defined in claim 184 wherein the processor is operable to generate a plurality of different casino games and wherein the plurality of different games are stored on the disk memory.

194. The casino gaming apparatus as defined in claim 184 wherein in response to receiving a selection of a first casino game from a plurality of different casino games, the casino gaming apparatus is operable to generate a play of the first casino game on the casino gaming apparatus.

195. The casino gaming apparatus as defined in claim 184 further comprising a sound-generating apparatus operatively coupled to the processor.

196. A casino gaming apparatus, comprising:

a casino game console;

a video display unit;

a main memory providing an executable space for a processor disposed in said casino game console;

a disk memory having gaming data relating to a casino game including program data and image data stored therein;

a memory storing software for controlling the disk memory wherein the software is authenticated prior to the gaming data related to the casino game;

a nonvolatile memory operable to store gaming data at least related to play of the casino game;

wherein at least a portion of the gaming data is authenticated while the casino gaming apparatus is available for game play; and

the processor disposed in said casino game console and being operatively coupled to said video display unit, said main memory, said memory, said nonvolatile memory and said disk memory,

said processor operable to cause said gaming data to be authenticated based on a comparison of a first hash value generated from at least a portion of said gaming data relating to casino game with a second hash value generated from known gaming data.

197. The casino gaming apparatus as defined in claim 196 wherein said processor is operable to send information relating to the authentication of the gaming data to a remote device.

198. The casino gaming apparatus as defined in claim 196 wherein said processor is operable to display information relating to the authentication of the gaming data on the video display unit.

199. The casino gaming apparatus as defined in claim 196, further comprising a fifth memory configured to store a random number generator program used for generating outcomes for the casino game wherein the random number generator program is stored and authenticated separately from the gaming data.

200. The casino gaming apparatus as defined in claim 196, further comprising a fifth memory, coupled to the

processor, configured to store a boot code for the casino gaming apparatus.

201. The casino gaming apparatus as defined in claim 196, wherein, in response to an event generated while the casino gaming apparatus is available for game play, at least a portion of the gaming data is authenticated.

202. The casino gaming apparatus as defined in claim 196 further comprising a secure loader adapted to control a loading of the portions of the gaming data related to the casino game from the disk memory.

203. The casino gaming apparatus as defined in claim 196 further comprising at least one peripheral device coupled to the casino game console including a memory device wherein the processor is operable to authenticate contents of the memory device.

204. The casino gaming apparatus as defined in claim 196 wherein the video display unit is disposed in a remote location separate from said casino game console.

205. The casino gaming apparatus as defined in claim 196 further comprising a video subsystem, operatively coupled to the video display unit and operatively coupled to the processor, adapted for displaying still images, motion video or combinations thereof.

206. The casino gaming apparatus as defined in claim 196 wherein the processor is operable to generate a plurality of different casino games and wherein the plurality of different games are stored on the disk memory.

207. The casino gaming apparatus as defined in claim 196 wherein in response to receiving a selection of a first casino game from a plurality of different casino games, the casino gaming apparatus is operable to generate a play of the first casino game on the casino gaming apparatus.

208. The casino gaming apparatus as defined in claim 196 further comprising a sound-generating apparatus operatively coupled to the processor.

209. A casino gaming apparatus, comprising:

a casino game console;

a video display unit;

a main memory providing an executable space for a processor disposed in said casino game console;

a disk memory having gaming data relating to a casino game including program data and image data stored therein;

a memory storing software for controlling the disk memory wherein the software is authenticated prior to the gaming data related to the casino game;

a nonvolatile memory operable to store gaming data at least related to play of the casino game;

at least one peripheral device coupled to the casino game console including a memory device wherein the processor is operable to authenticate contents of the memory device; and

the processor disposed in said casino game console and being operatively coupled to said video display unit, said main memory, said memory, said nonvolatile memory and said disk memory,

said processor operable to cause said gaming data to be authenticated based on a comparison of a first hash value generated from at least a portion of said gaming data relating to casino game with a second hash value generated from known gaming data.

210. The casino gaming apparatus as defined in claim 209 wherein said processor is operable to send information relating to the authentication of the gaming data to a remote device.

211. The casino gaming apparatus as defined in claim 209 wherein said processor is operable to display information relating to the authentication of the gaming data on the video display unit.

212. The casino gaming apparatus as defined in claim 209, further comprising a fifth memory configured to store a random number generator program used for generating outcomes for the casino game wherein the random number generator program is stored and authenticated separately from the gaming data.

213. The casino gaming apparatus as defined in claim 209, further comprising a fifth memory, coupled to the processor, configured to store a boot code for the casino gaming apparatus.

214. The casino gaming apparatus as defined in claim 209, wherein, in response to an event generated while the casino gaming apparatus is available for game play, at least a portion of the gaming data is authenticated.

215. The casino gaming apparatus as defined in claim 209 further comprising a secure loader adapted to control a loading of the portions of the gaming data related to the casino game from the disk memory.

216. The casino gaming apparatus as defined in claim 209 wherein at least a portion of the gaming data is authenticated while the casino gaming apparatus is available for game play.

217. The casino gaming apparatus as defined in claim 209 wherein the video display unit is disposed in a remote location separate from said casino game console.

218. The casino gaming apparatus as defined in claim 209 further comprising a video subsystem, operatively coupled to the video display unit and operatively coupled to the processor, adapted for displaying still images, motion video or combinations thereof.

219. The casino gaming apparatus as defined in claim 209 wherein the processor is operable to generate a plurality of different casino games and wherein the plurality of different games are stored on the disk memory.

220. The casino gaming apparatus as defined in claim 209 wherein in response to receiving a selection of a first casino game from a plurality of different casino games, the casino gaming apparatus is operable to generate a play of the first casino game on the casino gaming apparatus.

221. The casino gaming apparatus as defined in claim 209 further comprising a sound-generating apparatus operatively coupled to the processor.

222. A casino gaming apparatus, comprising:

a casino game console;

a video display unit;

a main memory providing an executable space for a processor disposed in said casino game console;

a disk memory having gaming data relating to a casino game including program data and image data stored therein;

a memory storing software for controlling the disk memory wherein the software is authenticated prior to the gaming data related to the casino game;

a nonvolatile memory operable to store gaming data at least related to play of the casino game;

wherein the video display unit is disposed in a remote location separate from said casino game console; and

the processor disposed in said casino game console and being operatively coupled to said video display unit, said main memory, said memory, said nonvolatile memory and said disk memory,

said processor operable to cause said gaming data to be authenticated based on a comparison of a first hash value generated from at least a portion of said gaming data relating to casino game with a second hash value generated from known gaming data.

223. The casino gaming apparatus as defined in claim 222 wherein said processor is operable to send information relating to the authentication of the gaming data to a remote device.

224. The casino gaming apparatus as defined in claim 222 wherein said processor is operable to display information relating to the authentication of the gaming data on the video display unit.

225. The casino gaming apparatus as defined in claim 222, further comprising a fifth memory configured to store a random number generator program used for generating outcomes for the casino game wherein the random number generator program is stored and authenticated separately from the gaming data.

226. The casino gaming apparatus as defined in claim 222, further comprising a fifth memory, coupled to the processor, configured to store a boot code for the casino gaming apparatus.

227. The casino gaming apparatus as defined in claim 222, wherein, in response to an event generated while the casino gaming apparatus is available for game play, at least a portion of the gaming data is authenticated.

228. The casino gaming apparatus as defined in claim 222 further comprising a secure loader adapted to control a loading of the portions of the gaming data related to the casino game from the disk memory.

229. The casino gaming apparatus as defined in claim 222 wherein at least a portion of the gaming data is authenticated while the casino gaming apparatus is available for game play.

230. The casino gaming apparatus as defined in claim 222 further comprising at least one peripheral device coupled to the casino game console including a memory device wherein the processor is operable to authenticate contents of the memory device.

231. The casino gaming apparatus as defined in claim 222 further comprising a video subsystem, operatively coupled to the video display unit and operatively coupled to the processor, adapted for displaying still images, motion video or combinations thereof.

232. The casino gaming apparatus as defined in claim 222 wherein the processor is operable to generate a plurality of different casino games and wherein the plurality of different games are stored on the disk memory.

233. The casino gaming apparatus as defined in claim 222 wherein in response to receiving a selection of a first casino game from a plurality of different casino games, the casino gaming apparatus is operable to generate a play of the first casino game on the casino gaming apparatus.

234. The casino gaming apparatus as defined in claim 222 further comprising a sound-generating apparatus operatively coupled to the processor.

235. A casino gaming apparatus, comprising:

a casino game console;

a video display unit;

a main memory providing an executable space for a processor, said main memory being disposed in said casino game console,

a disk memory, said disk memory having gaming data relating to a casino game stored therein;

a memory storing system logic for reading files in a file system on the disk memory wherein the system logic

is authenticated prior to authenticating the gaming data, said memory being disposed in said casino game console;

a fourth memory configured to store a random number generator program used for generating outcomes for the casino game wherein the random number generator program is stored and authenticated separately from the gaming data; and

the processor disposed in said casino game console and being operatively coupled to said video display unit, said main memory, said memory and said disk memory;

said processor operable to cause said gaming data to be authenticated based on a comparison of data generated by said processor from a hash function applied to said gaming data with data generated from the hash function applied to known gaming data, and

said processor operable to cause a remedial action to be taken based on an outcome of said authentication of said gaming data.

236. The casino gaming apparatus as defined in claim 235 wherein said processor is operable to send information relating to the authentication of the gaming data to a remote device.

237. The casino gaming apparatus as defined in claim 235 wherein said processor is operable to display information relating to the authentication of the gaming data on the video display unit.

238. The casino gaming apparatus as defined in claim 235, wherein the memory and the fourth memory are located on a same memory device.

239. The casino gaming apparatus as defined in claim 235, wherein, in response to an event generated while the casino gaming apparatus is available for game play, at least a portion of the gaming data is authenticated.

240. The casino gaming apparatus as defined in claim 235, wherein at least a portion of the gaming data is authenticated while the casino gaming apparatus is available for game play.

241. The casino gaming apparatus as defined in claim 235 wherein the processor is operable to cause information related to the authentication to be transferred to a remote storage device.

242. The casino gaming apparatus as defined in claim 235 wherein the system logic is a function of an operating system.

243. The casino gaming apparatus as defined in claim 235 further comprising at least one peripheral device coupled to the casino game console including a memory device wherein the processor is operable to authenticate contents of the memory device.

244. The casino gaming apparatus as defined in claim 235 wherein the video display unit is disposed in a remote location separate from said casino game console.

245. The casino gaming apparatus as defined in claim 235 further comprising a video subsystem, operatively coupled to the video display unit and operatively coupled to the processor, adapted for displaying still images, motion video or combinations thereof.

246. The casino gaming apparatus as defined in claim 235 wherein the processor is operable to generate a plurality of different casino games and wherein the plurality of different games are stored on the disk memory.

247. The casino gaming apparatus as defined in claim 235 wherein in response to receiving a selection of a first casino game from a plurality of different casino games,

the casino gaming apparatus is operable to generate a play of the first casino game on the casino gaming apparatus.

248. The casino gaming apparatus as defined in claim 235 further comprising a sound-generating apparatus operatively coupled to the processor.

249. The casino gaming apparatus as defined in claim 235 further comprising a nonvolatile memory operable to store gaming data at least related to play of the casino game.

250. A casino gaming apparatus, comprising:

a casino game console;

a video display unit;

a main memory providing an executable space for a processor, said main memory being disposed in said casino game console,

a disk memory, said disk memory having gaming data relating to a casino game stored therein;

a memory storing system logic for reading files in a file system on the disk memory wherein the system logic is authenticated prior to authenticating the gaming data, said memory being disposed in said casino game console;

wherein, in response to an event generated while the casino gaming apparatus is available for game play, at least a portion of the gaming data is authenticated; and

the processor disposed in said casino game console and being operatively coupled to said video display unit, said main memory, said memory and said disk memory;

said processor operable to cause said gaming data to be authenticated based on a comparison of data generated by said processor from a hash function applied to said gaming data with data generated from the hash function applied to known gaming data, and

said processor operable to cause a remedial action to be taken based on an outcome of said authentication of said gaming data.

251. The casino gaming apparatus as defined in claim 250 wherein said processor is operable to send information relating to the authentication of the gaming data to a remote device.

252. The casino gaming apparatus as defined in claim 250 wherein said processor is operable to display information relating to the authentication of the gaming data on the video display unit.

253. The casino gaming apparatus as defined in claim 250, further comprising a fourth memory configured to store a random number generator program used for generating outcomes for the casino game wherein the random number generator program is stored and authenticated separately from the gaming data.

254. The casino gaming apparatus as defined in claim 250, further comprising a fourth memory, coupled to the processor, configured to store a boot code for the casino gaming apparatus.

255. The casino gaming apparatus as defined in claim 250 wherein the processor is operable to cause information related to the authentication to be transferred to a remote storage device.

256. The casino gaming apparatus as defined in claim 250 wherein the system logic is a function of an operating system.

257. The casino gaming apparatus as defined in claim 250 further comprising a fourth memory storing a secure loader for loading the system logic.

258. The casino gaming apparatus as defined in claim 250 further comprising at least one peripheral device coupled to the casino game console including a memory device wherein the processor is operable to authenticate contents of the memory device.

259. The casino gaming apparatus as defined in claim 250 wherein the video display unit is disposed in a remote location separate from said casino game console.

260. The casino gaming apparatus as defined in claim 250 further comprising a video subsystem, operatively coupled to the video display unit and operatively coupled to the processor, adapted for displaying still images, motion video or combinations thereof.

261. The casino gaming apparatus as defined in claim 250 wherein the processor is operable to generate a plurality of different casino games and wherein the plurality of different games are stored on the disk memory.

262. The casino gaming apparatus as defined in claim 250 wherein in response to receiving a selection of a first casino game from a plurality of different casino games, the casino gaming apparatus is operable to generate a play of the first casino game on the casino gaming apparatus.

263. The casino gaming apparatus as defined in claim 250 further comprising a sound-generating apparatus operatively coupled to the processor.

264. The casino gaming apparatus as defined in claim 250 further comprising a nonvolatile memory operable to store gaming data at least related to play of the casino game.

265. A casino gaming apparatus, comprising:

a casino game console;

a video display unit;

a main memory providing an executable space for a processor, said main memory being disposed in said casino game console,

a disk memory, said disk memory having gaming data relating to a casino game stored therein;

a memory storing system logic for reading files in a file system on the disk memory wherein the system logic is authenticated prior to authenticating the gaming data, said memory being disposed in said casino game console;

wherein at least a portion of the gaming data is authenticated while the casino gaming apparatus is available for game play; and

the processor disposed in said casino game console and being operatively coupled to said video display unit, said main memory, said memory and said disk memory;

said processor operable to cause said gaming data to be authenticated based on a comparison of data generated by said processor from a hash function applied to said gaming data with data generated from the hash function applied to known gaming data, and

said processor operable to cause a remedial action to be taken based on an outcome of said authentication of said gaming data.

266. The casino gaming apparatus as defined in claim 265 wherein said processor is operable to send information relating to the authentication of the gaming data to a remote device.

267. The casino gaming apparatus as defined in claim 265 wherein said processor is operable to display information relating to the authentication of the gaming data on the video display unit.

268. The casino gaming apparatus as defined in claim 265, further comprising a fourth memory configured to store a random number generator program used for generating outcomes for the casino game wherein the random number generator program is stored and authenticated separately from the gaming data.

269. The casino gaming apparatus as defined in claim 265, further comprising a fourth memory, coupled to the processor, configured to store a boot code for the casino gaming apparatus.

270. The casino gaming apparatus as defined in claim 265, wherein, in response to an event generated while the casino gaming apparatus is available for game play, at least a portion of the gaming data is authenticated.

271. The casino gaming apparatus as defined in claim 265 wherein the processor is operable to cause information related to the authentication to be transferred to a remote storage device.

272. The casino gaming apparatus as defined in claim 265 wherein the system logic is a function of an operating system.

273. The casino gaming apparatus as defined in claim 265 further comprising a fourth memory storing a secure loader for loading the system logic.

274. The casino gaming apparatus as defined in claim 265 further comprising at least one peripheral device coupled to the casino game console including a memory device wherein the processor is operable to authenticate contents of the memory device.

275. The casino gaming apparatus as defined in claim 265 wherein the video display unit is disposed in a remote location separate from said casino game console.

276. The casino gaming apparatus as defined in claim 265 further comprising a video subsystem, operatively coupled to the video display unit and operatively coupled to the processor, adapted for displaying still images, motion video or combinations thereof.

277. The casino gaming apparatus as defined in claim 265 wherein the processor is operable to generate a plurality of different casino games and wherein the plurality of different games are stored on the disk memory.

278. The casino gaming apparatus as defined in claim 265 wherein in response to receiving a selection of a first casino game from a plurality of different casino games, the casino gaming apparatus is operable to generate a play of the first casino game on the casino gaming apparatus.

279. The casino gaming apparatus as defined in claim 265 further comprising a sound-generating apparatus operatively coupled to the processor.

280. The casino gaming apparatus as defined in claim 265 further comprising a nonvolatile memory operable to store gaming data at least related to play of the casino game.

281. A casino gaming apparatus, comprising:

a casino game console;

a video display unit;

a main memory providing an executable space for a processor, said main memory being disposed in said casino game console,

a disk memory, said disk memory having gaming data relating to a casino game stored therein;

a memory storing system logic for reading files in a file system on the disk memory wherein the system logic is authenticated prior to authenticating the gaming data, said memory being disposed in said casino game console;

at least one peripheral device coupled to the casino game console including a memory device wherein the processor is operable to authenticate contents of the memory device; and

the processor disposed in said casino game console and being operatively coupled to said video display unit, said main memory, said memory and said disk memory;

said processor operable to cause said gaming data to be authenticated based on a comparison of data generated by said processor from a hash function applied to said gaming data with data generated from the hash function applied to known gaming data, and

said processor operable to cause a remedial action to be taken based on an outcome of said authentication of said gaming data.

282. The casino gaming apparatus as defined in claim 281 wherein said processor is operable to send information relating to the authentication of the gaming data to a remote device.

283. The casino gaming apparatus as defined in claim 281 wherein said processor is operable to display information relating to the authentication of the gaming data on the video display unit.

284. The casino gaming apparatus as defined in claim 281, further comprising a fourth memory configured to store a random number generator program used for generating outcomes for the casino game wherein the random number generator program is stored and authenticated separately from the gaming data.

285. The casino gaming apparatus as defined in claim 281, further comprising a fourth memory, coupled to the processor, configured to store a boot code for the casino gaming apparatus.

286. The casino gaming apparatus as defined in claim 281, wherein, in response to an event generated while the casino gaming apparatus is available for game play, at least a portion of the gaming data is authenticated.

287. The casino gaming apparatus as defined in claim 281 wherein the processor is operable to cause information related to the authentication to be transferred to a remote storage device.

288. The casino gaming apparatus as defined in claim 281 wherein the system logic is a function of an operating system.

289. The casino gaming apparatus as defined in claim 281 further comprising a fourth memory storing a secure loader for loading the system logic.

290. The casino gaming apparatus as defined in claim 281 wherein at least a portion of the gaming data is authenticated while the casino gaming apparatus is available for game play.

291. The casino gaming apparatus as defined in claim 281 wherein the video display unit is disposed in a remote location separate from said casino game console.

292. The casino gaming apparatus as defined in claim 281 further comprising a video subsystem, operatively coupled to the video display unit and operatively coupled to the processor, adapted for displaying still images, motion video or combinations thereof.

293. The casino gaming apparatus as defined in claim 281 wherein the processor is operable to generate a plurality of different casino games and wherein the plurality of different games are stored on the disk memory.

294. The casino gaming apparatus as defined in claim 281 wherein in response to receiving a selection of a first

casino game from a plurality of different casino games, the casino gaming apparatus is operable to generate a play of the first casino game on the casino gaming apparatus.

295. The casino gaming apparatus as defined in claim 281 further comprising a sound-generating apparatus operatively coupled to the processor.

296. The casino gaming apparatus as defined in claim 281 further comprising a nonvolatile memory operable to store gaming data at least related to play of the casino game.

297. A casino gaming apparatus, comprising:

a casino game console;

a video display unit wherein the video display unit is disposed in a remote location separate from said casino game console;

a main memory providing an executable space for a processor, said main memory being disposed in said casino game console;

a disk memory, said disk memory having gaming data relating to a casino game stored therein;

a memory storing system logic for reading files in a file system on the disk memory wherein the system logic is authenticated prior to authenticating the gaming data, said memory being disposed in said casino game console; and

the processor disposed in said casino game console and being operatively coupled to said video display unit, said main memory, said memory and said disk memory;

said processor operable to cause said gaming data to be authenticated based on a comparison of data generated by said processor from a hash function applied to said gaming data with data generated from the hash function applied to known gaming data, and

said processor operable to cause a remedial action to be taken based on an outcome of said authentication of said gaming data.

298. The casino gaming apparatus as defined in claim 297 wherein said processor is operable to send information relating to the authentication of the gaming data to a remote device.

299. The casino gaming apparatus as defined in claim 297 wherein said processor is operable to display information relating to the authentication of the gaming data on the video display unit.

300. The casino gaming apparatus as defined in claim 297, further comprising a fourth memory configured to store a random number generator program used for generating outcomes for the casino game wherein the random number generator program is stored and authenticated separately from the gaming data.

301. The casino gaming apparatus as defined in claim 297, further comprising a fourth memory, coupled to the processor, configured to store a boot code for the casino gaming apparatus.

302. The casino gaming apparatus as defined in claim 297, wherein, in response to an event generated while the casino gaming apparatus is available for game play, at least a portion of the gaming data is authenticated.

303. The casino gaming apparatus as defined in claim 297 wherein the processor is operable to cause information related to the authentication to be transferred to a remote storage device.

304. The casino gaming apparatus as defined in claim 297 wherein the system logic is a function of an operating system.

305. The casino gaming apparatus as defined in claim 297 further comprising a fourth memory storing a secure loader for loading the system logic.

306. The casino gaming apparatus as defined in claim 297 wherein at least a portion of the gaming data is authenticated while the casino gaming apparatus is available for game play.

307. The casino gaming apparatus as defined in claim 297 further comprising at least one peripheral device coupled to the casino game console including a memory device wherein the processor is operable to authenticate contents of the memory device.

308. The casino gaming apparatus as defined in claim 297 further comprising a video subsystem, operatively coupled to the video display unit and operatively coupled to the processor, adapted for displaying still images, motion video or combinations thereof.

309. The casino gaming apparatus as defined in claim 297 wherein the processor is operable to generate a plu-

rality of different casino games and wherein the plurality of different games are stored on the disk memory.

310. The casino gaming apparatus as defined in claim 297 wherein in response to receiving a selection of a first casino game from a plurality of different casino games, the casino gaming apparatus is operable to generate a play of the first casino game on the casino gaming apparatus.

311. The casino gaming apparatus as defined in claim 297 further comprising a sound-generating apparatus operatively coupled to the processor.

312. The casino gaming apparatus as defined in claim 297 further comprising a nonvolatile memory operable to store gaming data at least related to play of the casino game.

\* \* \* \* \*