



US00RE39248E

(19) **United States**
(12) **Reissued Patent**
Vito

(10) **Patent Number: US RE39,248 E**
(45) **Date of Reissued Patent: Aug. 29, 2006**

(54) **ANTI-THEFT BRAKE LOCKING DEVICE**

FOREIGN PATENT DOCUMENTS

(75) Inventor: **Robert A. Vito**, Berwyn, PA (US)
(73) Assignee: **Unbreakable Company**, Berwyn, PA (US)
(21) Appl. No.: **09/783,774**
(22) Filed: **Feb. 15, 2001**

DE	92 15 118.3	U1	2/1993
DE	297 19 904	U1	2/1998
EP	0 404 709	A1	12/1990
FR	862 868		3/1941
FR	2 419 846		10/1979
FR	2422529	*	11/1979
FR	2 579 943	A1	10/1986
FR	2 580 243	A	10/1986
FR	2 681 823	A1	4/1993
FR	2 719 005	A1	10/1995
FR	2744409	*	8/1997
GB	160160	*	12/1921
GB	1033994		6/1966
GB	2 023 520	A	1/1980
GB	2091656	A	8/1982
GB	2 246 105	A	1/1992
GB	2 255 060	A	10/1992
WO	WO 97/15476		5/1997
WO	WO 99/19643		4/1999

Related U.S. Patent Documents

Reissue of:

(64) Patent No.: **5,870,912**
Issued: **Feb. 16, 1999**
Appl. No.: **08/949,009**
Filed: **Oct. 10, 1997**

(51) **Int. Cl.**
F16H 57/00 (2006.01)

(52) **U.S. Cl.** **70/202; 70/201; 70/237**

(58) **Field of Classification Search** **70/198-204, 70/209, 237, 238**

See application file for complete search history.

Primary Examiner—Suzanne Barrett

(74) *Attorney, Agent, or Firm*—Volpe and Koenig, P.C.

(57) **ABSTRACT**

A device for locking [the] a brake pedal and brake pedal shaft of a vehicle, [and preventing its theft comprising:] which includes a base member for a placement on [the] a floorboard of [a] the vehicle beneath [a] the brake pedal[:] and brake pedal shaft. [a] A U-shaped housing [extending] extends downward and [having] has a first arm attached to the base and [having] a second shorter arm defining [a gap] an opening for receipt of [a] the brake pedal shaft[, said space]. The opening between the first and second arms [defining] defines a slot for receiving the brake pedal shaft and [permitting its] permits full extension of the brake pedal shaft upward through said [shaft; and] slot. A locking [means] mechanism is associated with the [second] first arm for locking [the] an underside of the pedal shaft within the slot such that the brake pedal cannot be depressed.

(56) **References Cited**

U.S. PATENT DOCUMENTS

2,330,536	A	9/1943	Zimmermann	
3,245,239	A	4/1966	Zaidener	
3,889,499	A	* 6/1975	Cramer	70/202
4,040,675	A	8/1977	Richmond	
4,493,198	A	1/1985	Brown	
4,779,435	A	* 10/1988	Farrow	70/202 X
4,934,492	A	6/1990	Hayes-Sheen	
5,040,387	A	8/1991	Knott, Jr.	
5,267,458	A	* 12/1993	Heh	70/202 X
5,282,373	A	* 2/1994	Riccitelli	70/209
5,345,796	A	9/1994	Chieh et al.	
5,354,031	A	10/1994	Bilotti	

(Continued)

8 Claims, 2 Drawing Sheets

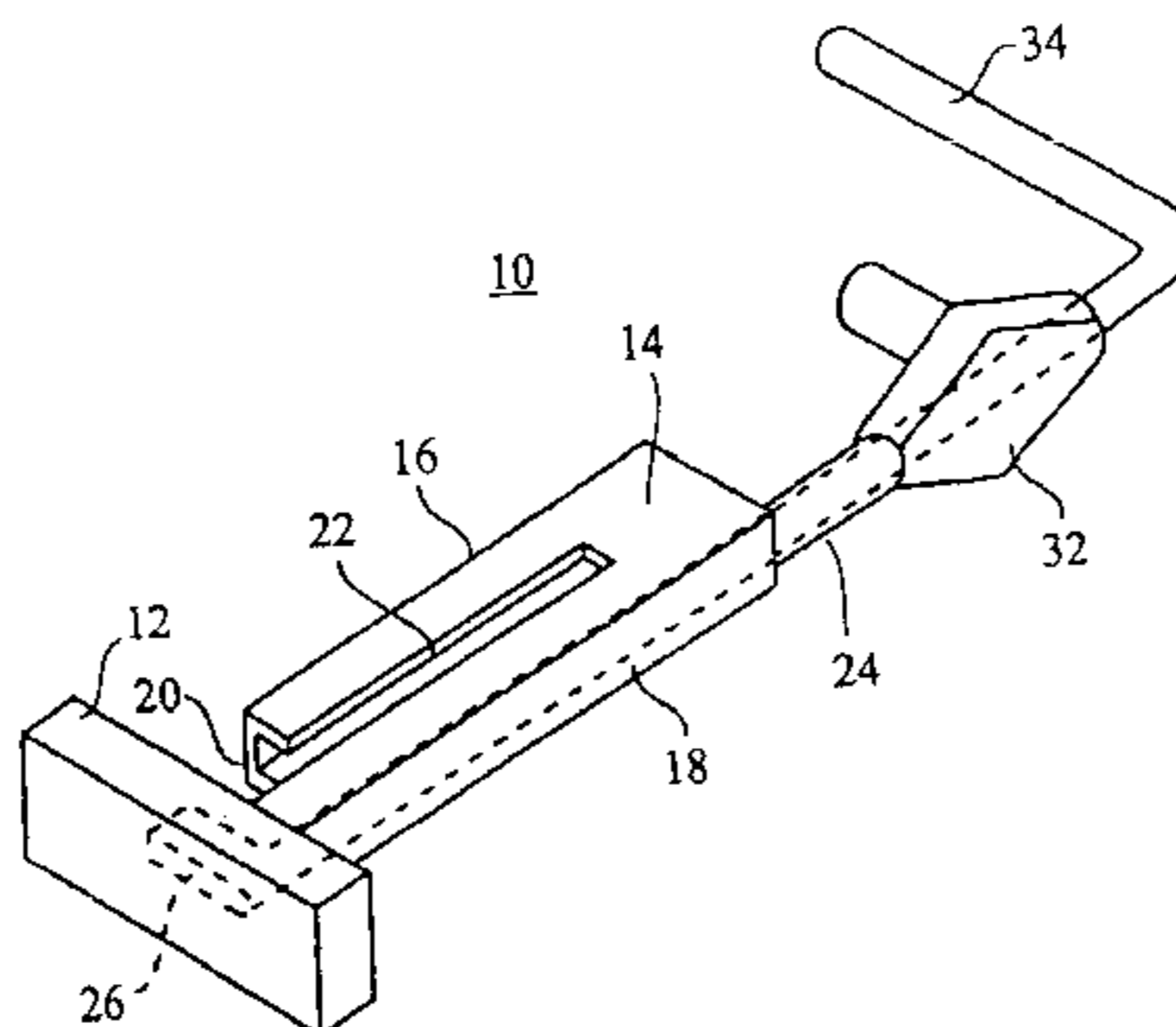

AMENDED

US RE39,248 E

Page 2

U.S. PATENT DOCUMENTS

5,537,846	A	*	7/1996	Simon	70/201	X	5,906,121	A	5/1999	Mankarious
5,653,133	A		8/1997	Passantino			5,911,765	A	6/1999	DaSilva
5,678,433	A	*	10/1997	Riccitelli	70/209		5,950,463	A	9/1999	Glazier et al.
5,704,233	A	*	1/1998	Farshad	70/199	X	5,979,197	A	11/1999	Mellini et al.
5,715,710	A	*	2/1998	DeLucia	70/202		6,089,055	A	7/2000	Vito
5,778,706	A		7/1998	Testa			6,192,724	B1	2/2001	Vito
5,870,912	A		2/1999	Vito			6,202,456	B1	3/2001	Vickers
5,881,587	A		3/1999	Vito						

* cited by examiner

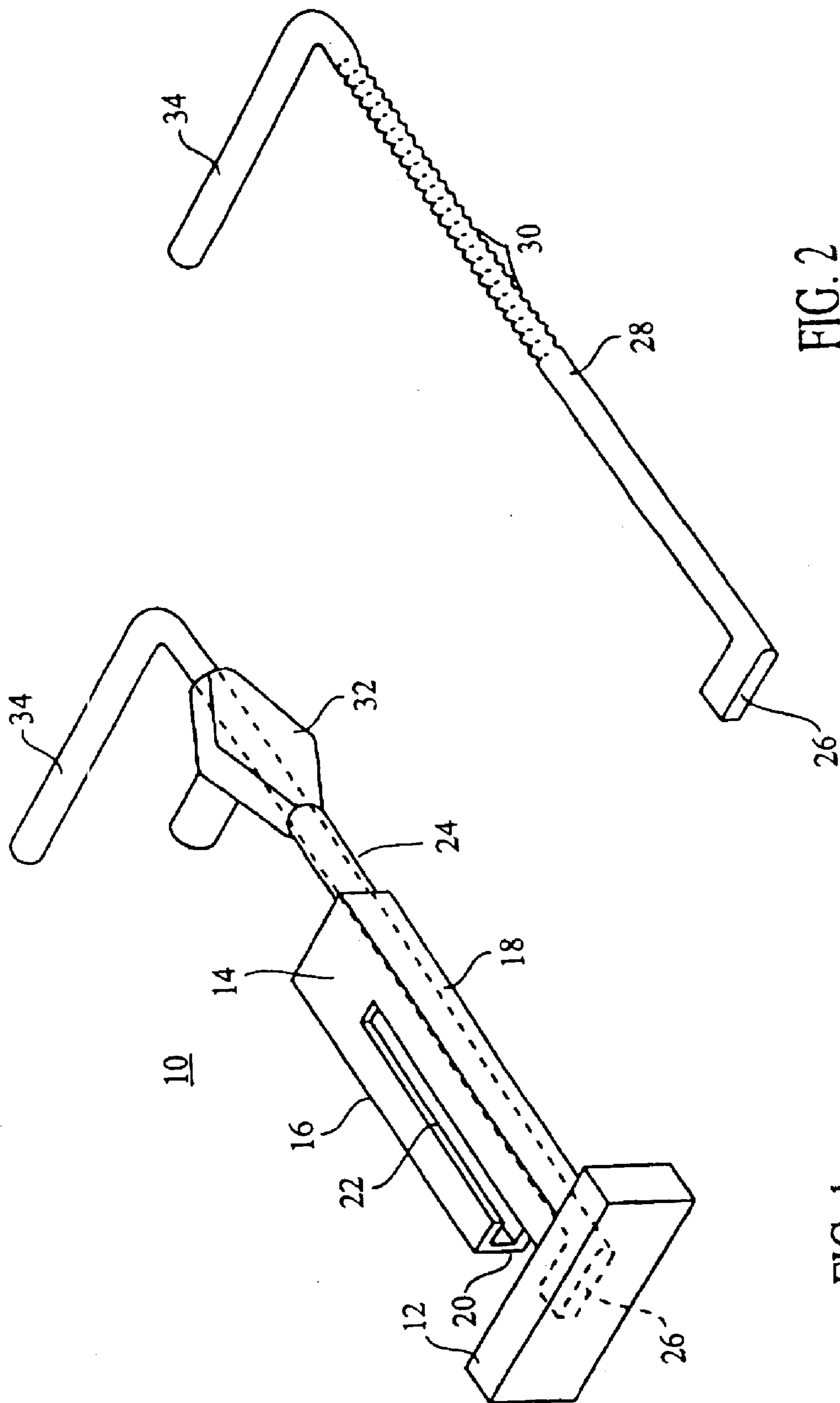

FIG. 1
AMENDED

FIG. 2

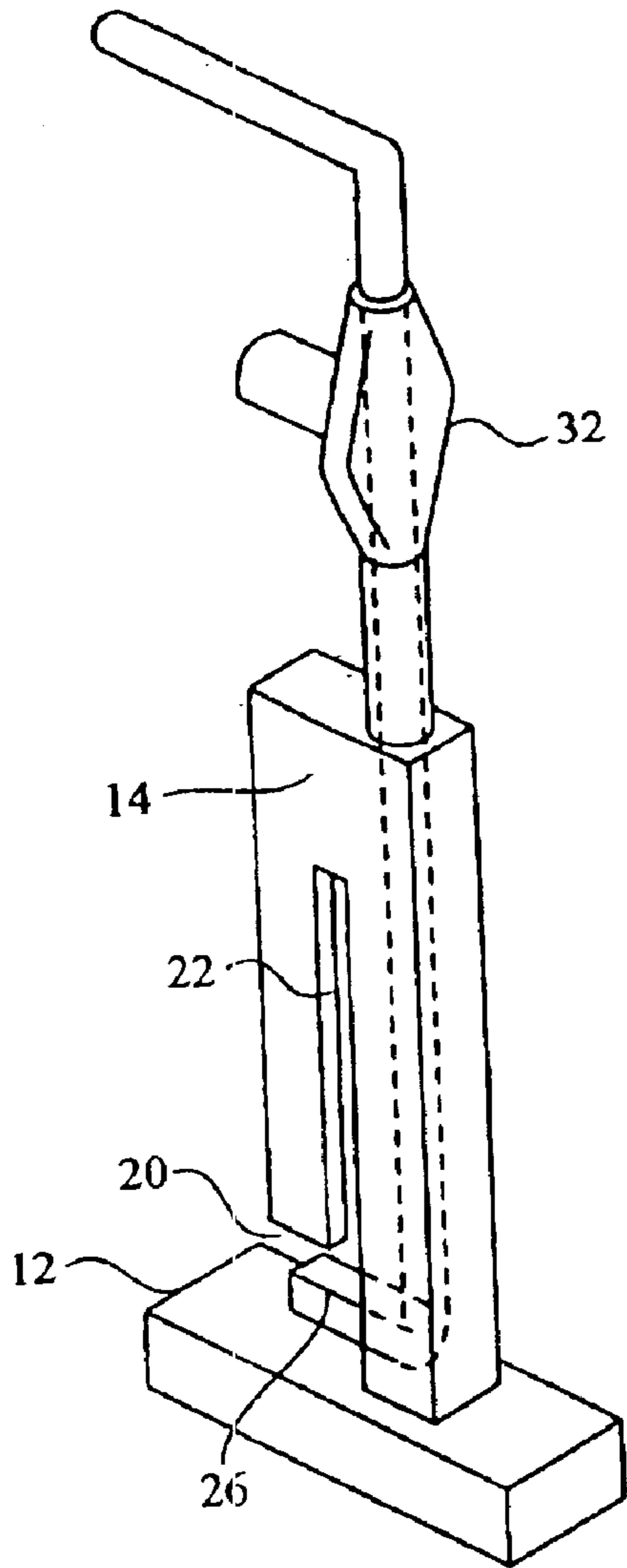

FIG. 3
AMENDED

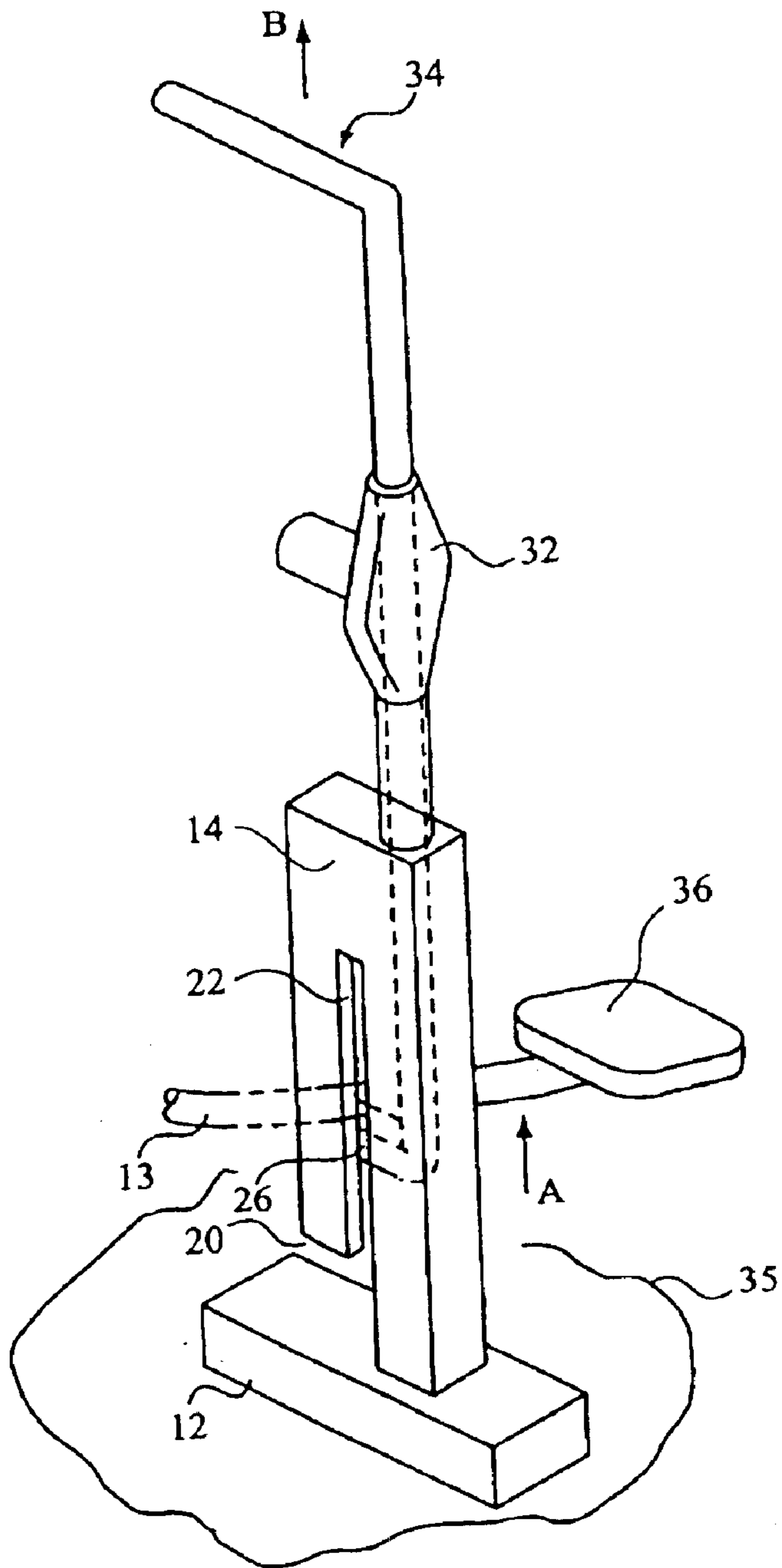

FIG. 4
AMENDED

ANTI-THEFT BRAKE LOCKING DEVICE

Matter enclosed in heavy brackets [] appears in the original patent but forms no part of this reissue specification; matter printed in italics indicates the additions made by reissue.

FIELD OF THE INVENTION

This invention relates to an anti-theft brake-locking device for vehicles, which is particularly suitable for automatic transmission vehicles. More particularly, this invention relates to a device which prevents the brake pedal from being depressed.

BACKGROUND OF THE INVENTION

The proliferation of mechanical type and theft devices for motor vehicles have resulted in the commercial availability of different types of anti-theft devices. One type of prior art system mechanically locks brake and accelerator by means of two independent or articulated shoes which lock the pedals. The major problem stemming from such devices is that the driver has to reach out for the pedal area or actually get down on his or her knees in order to operate the locking device and the varying distance between the brake and accelerator which can prevent the device from being installed.

More recently, some devices have been suggested which are constructed from a long rod consisting of an anti-picking material and which is provided at both ends with two shaped members that couple respectively with a pedal and with the steering wheel or the vehicle. The coupling with the steering wheel is locked using a safety lock that prevents the same from being disengaged. This device, which owing to its characteristics can be employed on traditional transmission cars as well as on automatic transmission vehicles is affected in the main by two drawbacks.

First, the connection, due to its longitudinal size and cumbersome nature is difficult to store when the device is not being utilized. Secondly, devices of this nature actually have a poor record against theft. Indeed, it is relatively easy to cut the rim of the steering wheel by means of a saw or the like. The rim is usually not a viable obstacle for thieves, and the anti-theft device can be disengaged merely pulling apart the two ends of the rim. Such devices are also not usually adaptable for automatic transmission vehicles because of their structural characteristics.

In UK patent application No. 2,091,656 an anti-theft pedal-locking device for vehicles is described comprising a first supporting member extending upwards and provided with a safety lock and with a laterally projecting member, a second supporting member, upon which the first supporting member slides, with a projecting member cooperating with the corresponding member of the first supporting member so as to lock a pedal of the vehicle when the latter member is in its lower position, while the lower end of the second supporting member may carry a base member to rest on the floor of the vehicle.

A number of United States Patents have also issued on brake locking mechanisms. U.S. Pat. No. 4,040,675 discloses a vehicle anti-theft device which maintains the braking function of the braking fluid by preventing reverse flow thereof from the wheel cylinder back to the master cylinder until as authorized procedure permits said backflow.

U.S. Pat. No. 4,493,198 discloses an anti-theft lock for a pedal operated apparatus. The invention incorporates first

and second stop bodies which are arranged to clamp around the lever of a pedal. When the stop bodies are locked in place, the pedal cannot be operated unless the apparatus is restrained.

U.S. Pat. No. 4,934,492 discloses an automatic brake-locking mechanism which locks the brake of a vehicle having a hydraulic brake system. The system incorporates a safety switch provided to operate in conjunction with the ignition switch so that the safety switch and the ignition both must be operated to an "on" position to release the auxiliary brake device to allow normal operation of the vehicle.

U.S. Pat. No. 5,040,387 similarly discloses a vehicle brake lock assembly which engages a brake pedal and which includes a U-shaped end portion which engages the brake pedal telescopically to lock the brake pedal in position.

U.S. Pat. No. 5,345,796 discloses a vehicle brake-pedal locking device which mechanically maintains the vehicle brake pedal in a depressed position to prevent the vehicle from being driven. The device includes a horizontally and vertically pivoting brake-pedal swing arm interfacing structure.

Finally, U.S. Pat. No. 5,653,133 discloses an anti-theft device for vehicles having a steering wheel and a brake. The device comprises a brake guard moveably mounted to a fixed portion of the brake, a lower elongated member which hooks to the brake guard, an upper elongated member which is locked to the lower elongated member, a wide bar spaced a distance adaptable to be placed around the steering wheel and a locking bar and a claw member. When the device is secured with two padlocks, movement of the steering wheel and the brake pedal is prevented.

While the prior art is replete with mechanisms and inventions for locking the brake pedals of a vehicle, there is no simple and easy system ever devised for swiftly securing the brake pedal in a non-depressible state without the driver or operator having to get down on his or her knees or crouch down. Such a system would be to disable a vehicle, because automobiles built since 1990 cannot start and be placed into gear without the brake pedal being depressed.

The present invention is thus directed to a brake lock mechanism which does not require the driver or vehicle operator to get down on his knees or to move beneath the vehicle and which prevent the brake from being depressed. These and other objects of the present invention will be described with reference to the following summary and detailed description.

SUMMARY OF THE INVENTION

In accordance with the present invention, a device for locking the brake of a vehicle and preventing its theft is disclosed. The invention comprises a base member for a placement on the floorboard of a vehicle beneath a brake pedal; a U-shaped housing extending downward and having a first arm attached to the base and having a second shorter arm defining a gap for receipt of a brake pedal shaft, said space between the first and second arms defining a slot for receiving the brake pedal shaft and permitting its fall extension upward through said shaft; and locking means associated with the second arm for locking the underside of the pedal within the slot such that the brake pedal cannot be depressed.

In a more preferred embodiment, the present invention is directed to a device for locking the brake of a vehicle and preventing its theft comprising: a base member for a placement on the floorboard of a vehicle beneath a brake pedal; a metallic U-shaped housing extending downward and hav-

ing a first arm attached to the base and having a second shorter arm defining an opening for receiving of a brake pedal shaft, said space between the first and second arms defining a slot for receiving the brake pedal shaft and permitting its full extension upward through said slot, said first arm having a cylindrical opening therethrough; a rod extending through said cylindrical opening and being slidable therewith, said rod having a pin which catches the underside of said brake pedal shaft and pulls it upward in a decompressed position; and locking means for locking the position of the rod and pin such that the that the brake pedal cannot be depressed.

In still a further embodiment, the present invention is directed to a device for locking the brake of a vehicle and preventing its theft comprising: a base member for a placement on the floorboard of a vehicle beneath a brake pedal; a steel U-shaped housing extending downward and having a first arm attached to the base and having a second shorter arm defining an opening for receiving of a brake pedal shaft, said space between the first and second arms defining a slot for receiving the brake pedal shaft and permitting its full extension upward through said slot, said first arm having a cylindrical opening extending therethrough and collinearly with said slot; a serrated rod extending through said cylindrical opening and being slidable therewith, said rod having a pin at first end for catching the underside of said brake pedal shaft and a handle at a second end for pulls it upward in a decompressed position; and locking means adapted to lock the serrated rod for locking the position of the rod and pin such that the that the brake pedal cannot be depressed.

BRIEF DESCRIPTION OF THE FIGURES

FIG. 1 is [an elevational] a perspective view of the brake anti-theft device of the present invention.

FIG. 2 is [an elevational] a perspective view of the handle and lock pin utilized with the brake lock mechanism of the brake anti-theft device of the present invention.

FIG. 3 is [an elevational] a perspective view of the brake anti-theft device of the present invention in an inactive position.

FIG. 4 is [an elevational] a perspective view of the brake anti-theft device of the present invention in an activated state.

DETAILED DESCRIPTION OF THE PREFERRED EMBODIMENT

The brake anti-theft device of the present invention is now described with reference to the enclosed Figures wherein the same numbers are utilized where applicable. In general, the present invention is a device specifically designed to lock the brake pedal of a motor vehicle in an up or non-depressed state. Because since 1990, vehicles manufactured for sale in North American cannot start without the depression of the brake pedal, the invention is specifically designed to prevent the brake pedal from being depressed thus, thereby disabling the vehicle and preventing its theft and use. A particular feature of the present invention is that it is intended to be utilized by the driver or operator from the comfort of the driver's seat of the vehicle without any need for the driver to get down on his hands or knees or crouch in order to place or adjust the system.

Referring now to FIGS. 1 to 4, the brake anti-theft device of the present invention 10 comprises a base 12 which is placed on the floor of the vehicle adjacent to the brake pedal 36 and shaft 13. The base 12 thereby is affixed flush to the

floorboard of the vehicle directly below the brake pedal 36 and pedal shaft 13.

Extending from the base 12 is a U-shaped steel housing 14 which extends downward. The U-shaped housing comprises two arms 16, 18. One arm 16 of the U-shaped housing is shorter than the other 18 thereby defining an opening 20 which extends to a slot 22 defined by the space between the legs of the U-shaped housing. The opening 20 facilitates the placement and removal of the brake pedal shaft 13.

In a preferred embodiment, slot 22 should have an approximate width of the steel brake pedal shaft 13 such that the brake pedal shaft 13 extends through the slot and up to an extended position. In this position, the pedal 36 can be depressed freely as it extends downward through said slot 22.

The invention further comprises a locking mechanism [24] 32 associated with a first arm 18 of the U-shaped housing. The second leg 18 of the U-shaped housing 14 includes a cylindrical tube 24 designed to encase a slidable locking pin 26 which is attached to the end of an extendible rod 28. The rod 28 contains machined lock ratchets or serrations 30 which extend out the tube of the rectangular steel housing to a locking mechanism 32. The second end of the rod 28 comprises a handle 34 which is used to pull the rod upward.

The preferred locking mechanism or means 32 which is utilized in the present invention may be a commercially available key operated steering wheel locking mechanisms. There are other locking mechanisms suggested by the present invention including combination locks. [Locks] The locking mechanism 32 locks the machine locked ratchets 30 at the appropriate point. As shown most clearly in FIG. 4, as the rod 28 extends upward, the pin 26 enters the slot 22, pulls up (Arrow A) and secures the bottom of the brake pedal shaft 13 so that it cannot be depressed. In this position, after being locking into place by pin 26, the brake pedal shaft cannot be depressed.

The operation of the present invention is now described with reference to the enclosed Figures and most particularly FIGS. 3 and 4. The driver or operator desiring to utilize the device 10 will unlock the device and lower the pin 26 all the way down to the base 12. The base 12 will then be placed on the [floor board] floorboard 35 under the brake pedal 36 and shaft 13. The brake pedal shaft 13 will then extend through the opening 20 in the U-shaped housing and into the slot 22 with the base positioned squarely on the [floor board] floorboard of the vehicle. The operator will then pull up the handle 34 (Arrow B) thus raising the locking pin 26 upward into the slot 22 and securing the [base] brake pedal shaft 13 at its bottom in an upward position. The vehicle operator will then lock the device in this position using the lock mechanism such that the brake pedal 36 cannot be depressed, thereby disabling the operation of the engine and vehicle.

The present invention has been described with reference to a preferred embodiment. It is to be appreciated that other embodiments fulfill the spirit and scope of the present invention and that the true nature and scope of the present invention is to be determined with reference to the claims appended hereto.

I claim:

1. A device for locking [the] a brake [of a vehicle and preventing the theft of said vehicle] pedal and brake shaft of a vehicle, said device comprising:
 - a base member for a placement on [the] a floorboard of [said] the vehicle beneath [a] the brake pedal and [a] brake pedal shaft;

5

- a U-shaped housing extending downward and having a first arm attached to [the] *said* base and having a second shorter arm defining a gap for receipt of the brake pedal shaft, said [space] *gap* between [the] *said* first and second arms defining a slot for receiving the brake pedal shaft and permitting the full extension of [said] *the* brake pedal shaft upward through said slot; and
- a locking mechanism associated with [the] *said* first arm for locking [the] *an* underside of the *brake* pedal shaft within [the] *said* slot such that the brake pedal cannot be depressed.
2. The device of claim 1 wherein said locking mechanism is activated by a key.
3. The device of claim 1 wherein said locking mechanism is activated by a combination.
4. A device for locking [the] *a* brake [of a vehicle and preventing the theft of said] *pedal and a brake pedal shaft of a vehicle, said device* comprising:
- a base member for placement on [the] *a* floorboard of [said] *the* vehicle beneath [a] *the* brake pedal and brake pedal shaft;
- a metallic U-shaped housing extending downward and having a first arm attached to [the] *said* base and having a second shorter arm defining an opening for receiving the brake pedal shaft, said [space] *opening* between [the] *said* first and second arms defining a slot for receiving the brake pedal shaft and permitting [the] full extension of [said] *the* brake pedal shaft both upward and downward through said slot, said first arm having a cylindrical opening therethrough;
- a rod extending through said cylindrical opening and being slidable [therewith] *therein*, said rod having a pin which catches [the] *an* underside of [said] *the* brake pedal shaft within [the] *said* slot and pulls the brake pedal shaft upward in a decompressed position; and
- a locking mechanism for locking [the] *a* position of [the] *said* rod and pin *with respect to said housing* such that the brake [or clutch] pedal cannot be depressed.
5. The device of claim 4 wherein said locking mechanism is activated by a key.
6. The device of claim 4 wherein said locking mechanism is activated by a combination.

6

7. A device for locking [the] *a* brake *pedal and brake pedal shaft* a vehicle [and preventing the theft of], said [vehicle] *device* comprising:
- a base member for a placement on [the] *a* floorboard of the vehicle beneath [a] *the* brake pedal and brake pedal shaft;
- a stainless steel U-shaped housing extending downward and having a first arm [attached to the] *disposed on said* base and having a second shorter arm defining an opening for receiving the brake pedal shaft, said [space] *opening* between [the] *said* first and second arms defining a slot for receiving the brake pedal shaft and permitting [the] full extension of said brake pedal shaft both upward and downward through said slot, said first arm having a cylindrical opening extending there-through [and collinearly with said slot] ;
- a serrated rod extending through said cylindrical opening and being slidable [therewith] *therein*, said rod having a pin at a first end for catching [the] *an* underside of [said] *the* brake pedal shaft within [the] *said* slot and a handle at a second end for pulling the brake pedal shaft upward in a decompressed position; and
- a locking mechanism adapted to lock the serrated rod and pin [in position] *with respect to said housing* such that the brake pedal cannot be depressed.
8. *An anti-theft device for locking a brake pedal and brake pedal shaft with respect to a floorboard of a vehicle, the device comprising:*
- a base member for a placement on the floorboard of the vehicle;*
- a first arm connected to said base member;*
- a second arm spaced from and extending generally parallel to said first arm to form an elongate slot between said first and second arms, said slot being sized to receive the brake pedal shaft and permitting a full extension of the brake pedal shaft through said slot; and*
- a locking mechanism operably associated with at least one of said first and second arms for locking at least a portion of the brake pedal shaft within said slot to thereby prevent depression of the brake pedal.*

* * * * *