



US00RE39225E

(19) **United States**
(12) **Reissued Patent**
Isaza et al.

(10) **Patent Number: US RE39,225 E**
(45) **Date of Reissued Patent: Aug. 8, 2006**

(54) **SYSTEM AND METHOD FOR ADJUSTABLE DISCONNECTION SENSITIVITY FOR DISCONNECTION AND OCCLUSION DETECTION IN A PATIENT VENTILATOR**
(75) Inventors: **Fernando J. Isaza**, Carlsbad, CA (US); **Stanley Y. Wong**, Rancho Santa Margarita, CA (US); **Peter Doyle**, Vista, CA (US)

3,877,467 A * 4/1975 Plicchi 128/202.22
3,916,888 A * 11/1975 Buck et al. 128/204.21
4,096,858 A * 6/1978 Eyrick et al. 128/205.16
4,155,357 A * 5/1979 Dahl 128/202.22
4,176,617 A * 12/1979 Pilipski 116/70
4,286,589 A * 9/1981 Thompson 128/202.22
4,287,886 A * 9/1981 Thompson 128/202.22

(Continued)

(73) Assignee: **Nellcor Puritan Bennett Incorporated**, Pleasanton, CA (US)
(21) Appl. No.: **09/811,104**
(22) Filed: **Mar. 16, 2001**
(Under 37 CFR 1.47)

FOREIGN PATENT DOCUMENTS

EP 0 099 743 * 2/1984
EP 0 459 647 * 12/1991
EP 0 742 027 * 11/1996

OTHER PUBLICATIONS

Drager—Evita Intensive Care Ventilator Instruction Manual.*

Marketing Brochure—Pediatric—Adult Star 1500 Ventilator—Infrasonics, Inc. Star Products.*

Primary Examiner—Aaron J. Lewis

(74) Attorney, Agent, or Firm—Baker Botts L.L.P.

(57) **ABSTRACT**

The system and method for detecting disconnection [and occlusion] of a tubing system of a patient ventilator detects disconnection of the tubing system, opens the exhalation valve, delivers an idle flow of breathing gas to the tubing system, disables breath triggering, and generates an alarm. A reconnection of the tubing system can also be detected, to initiate resumption of pressure supported inspiration. [For occlusion detection, the pressure drop in the tubing system is determined by pressure sensors in the inspiratory and expiratory airways of the tubing system. The two pressure drop values are compared, and once occlusion is detected, an alarm is generated, and the ventilator responds to protect the patient from over distension. Abatement of the occlusion can also be monitored in a pressure based occlusion status cycling mode, and the ventilator can revert back to normal ventilation when the circuit occlusion or exhaust port occlusion are not detected.]

2 Claims, 2 Drawing Sheets

Related U.S. Patent Documents

Reissue of:
(64) Patent No.: **5,881,717**
Issued: **Mar. 16, 1999**
Appl. No.: **08/818,173**
Filed: **Mar. 14, 1997**

(51) **Int. Cl.**
A61M 16/00 (2006.01)

(52) **U.S. Cl.** **128/202.22; 128/204.21; 128/204.23; 128/205.23**

(58) **Field of Classification Search** **128/200.24, 128/202.22, 204.21, 204.23, 205.23**
See application file for complete search history.

(56) **References Cited**

U.S. PATENT DOCUMENTS

3,120,843 A * 2/1964 Hyman 128/202.22
3,333,584 A * 8/1967 Andreasen et al. 128/202.22
3,595,228 A * 7/1971 Simon et al. 128/202.22
3,741,208 A * 6/1973 Jonsson et al. 128/204.21
3,811,400 A * 5/1974 Smilg 116/70
3,831,595 A * 8/1974 Valenta et al. 128/202.22
3,848,591 A * 11/1974 Smythe et al. 128/204.23
3,867,934 A * 2/1975 Ollivier 128/202.22

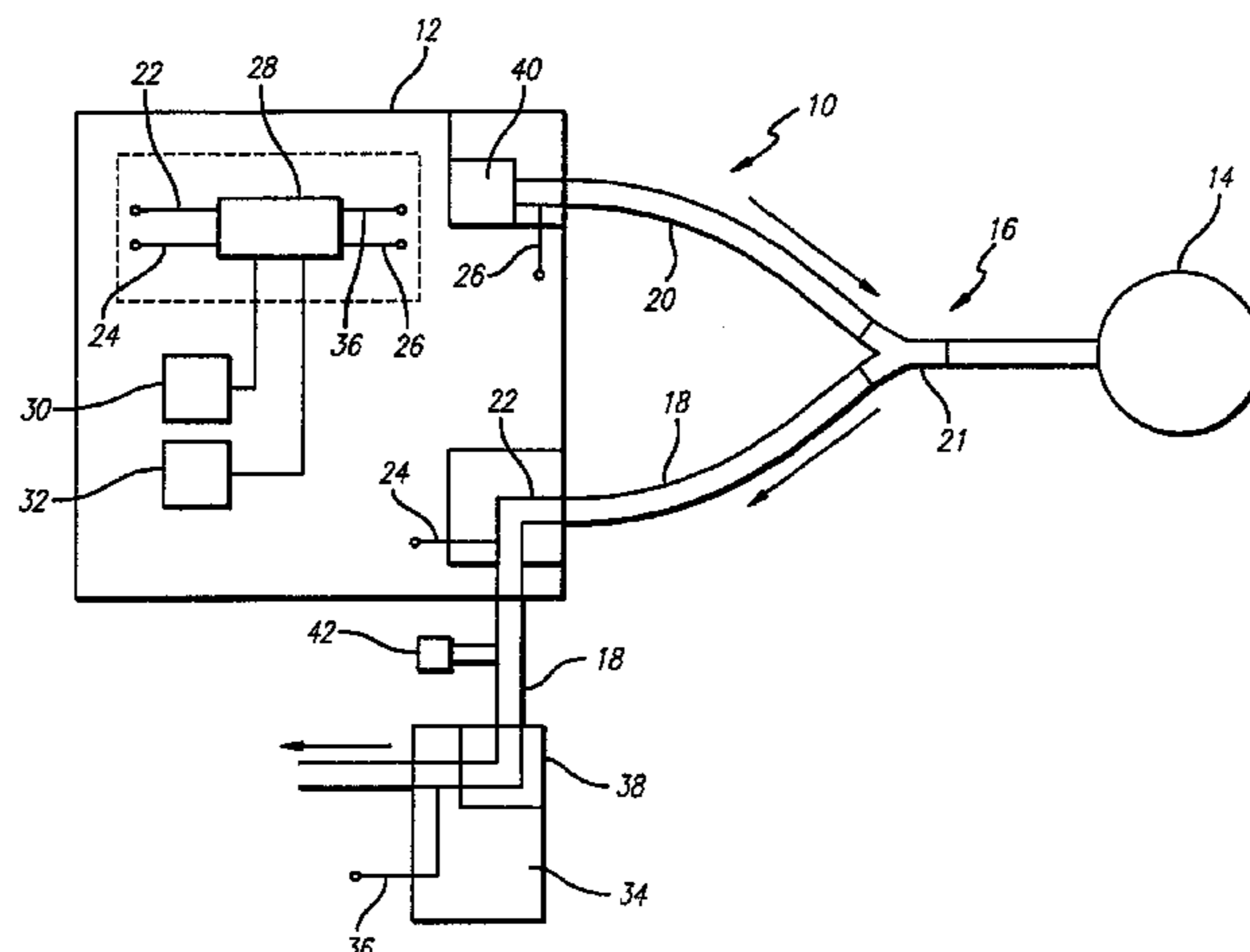

US RE39,225 E

Page 2

U.S. PATENT DOCUMENTS

4,302,640	A	*	11/1981	Vicenzi et al.	200/81 R	5,320,092	A	*	6/1994	Ryder	128/202.22
4,318,399	A	*	3/1982	Berndtsson	128/204.23	5,537,997	A	*	7/1996	Mechlenburg et al. .	128/204.23
4,550,726	A	*	11/1985	McEwen	128/202.22	5,626,129	A	*	5/1997	Klimm et al.	128/202.22
4,825,802	A	*	5/1989	Le Bec	116/70	5,715,812	A	*	2/1998	Deighan et al.	128/204.23
4,883,051	A	*	11/1989	Westenskow et al. ..	128/204.21	5,720,709	A	*	2/1998	Schnall	600/538
5,057,822	A	*	10/1991	Hoffman	340/611	5,740,796	A	*	4/1998	Skog	128/204.23
5,313,937	A	*	5/1994	Zdrojkowski	128/202.22						

* cited by examiner

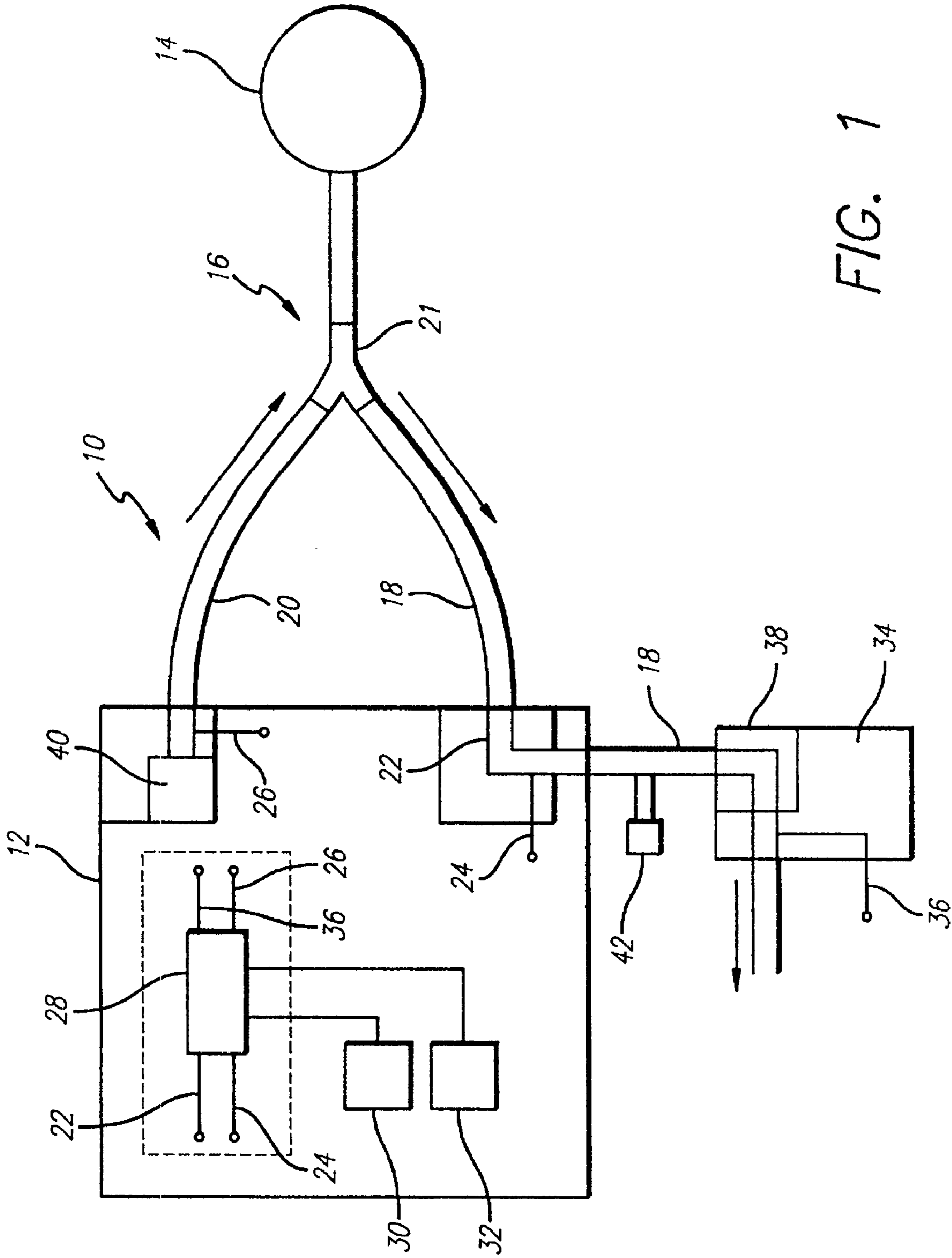

FIG. 1

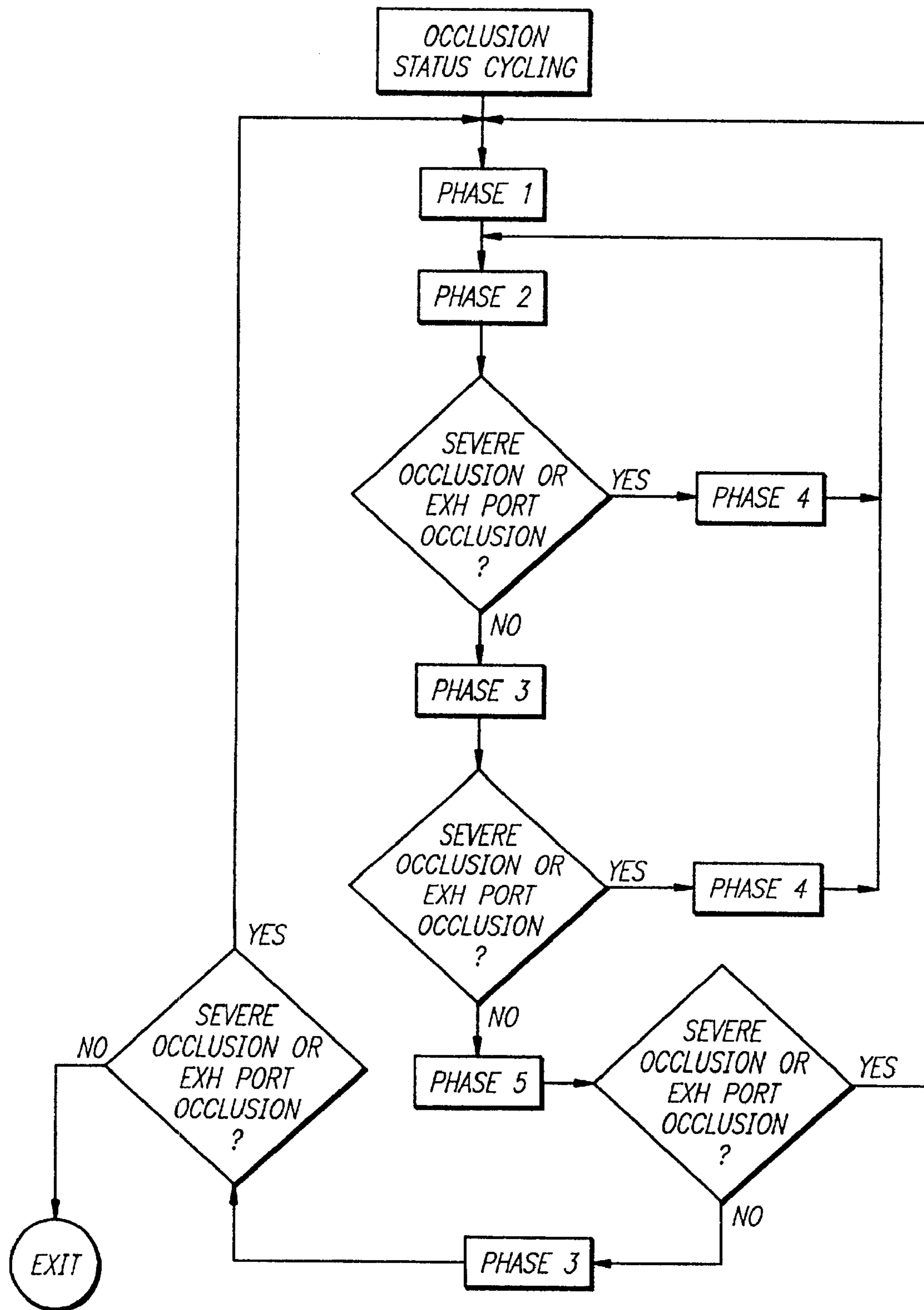

FIG. 2

1

**SYSTEM AND METHOD FOR ADJUSTABLE
DISCONNECTION SENSITIVITY FOR
DISCONNECTION AND OCCLUSION
DETECTION IN A PATIENT VENTILATOR**

Matter enclosed in heavy brackets [] appears in the original patent but forms no part of this reissue specification; matter printed in italics indicates the additions made by reissue.

BACKGROUND OF THE INVENTION

1. Field of the Invention

This invention relates generally to breathing ventilators, and more particularly relates to a pneumatically driven, electronically controlled ventilator system for providing breathing gas to a patient, and a method and system for detection of disconnection and occlusion in an airway of the ventilatory system.

2. Description of Related Art

A patient receiving breath pressure support from a ventilator system typically receives breathing gas through a patient circuit of the ventilator. The patient circuit generally consists of two flexible conduits connected to a fitting called a patient wye. The free ends of the conduits are attached to the ventilator so that one conduit receives breathing gas from the ventilator's pneumatic system, and the other conduit returns gas exhaled by the patient to the ventilator. The volume of the exhaled gas may then be measured in a spirometer before it finally exits through an exhalation valve. The wye fitting is typically connected to the patient's breathing attachment or enclosure, which conducts breathing gas into the lungs, and exhaled gas from the lungs to the exhalation branch of the patient circuit. The pneumatic system at the inspiratory end of the patient circuit is typically closed before a breath, and the exhalation valve at the exhalation end of the patient circuit is typically preceded by a one-way valve, to prevent gas from flowing retrograde in the exhalation branch of the patient circuit.

Occurrences of low pressures in the exhalation limb of the patient's breathing gas circuit during the exhalation phase of the presence supported breath can be a cause of concern for the patient unless they are carefully controlled. Pressures in the patient lung that fall below PEEP (Positive End Expiratory Pressure, a baseline pressure value) can impair a patient's lung function, and it can be important to maintain PEEP in a patient's lung to prevent collapse of the lung.

Disconnections of a patient breathing circuit can occur at the inspiratory limb, the expiratory limb, the patient circuit wye, or between the endotracheal tube and the patient wye. Patient either no breathing gas or very little gas from the ventilator, and can interfere severely with maintenance of PEEP. During ventilation, it is also desirable to be able to assess the state of the tubing system so that conditions such as kinked tubes and high resistance fillers that can occlude the flow of breathing gas and interference with maintenance of PEEP are detected, to prevent injury to the patient attached to the ventilator, and so that increases in the work of breathing are minimized. It is also important to detect an occlusion condition in which the exhalation valve is stuck closed. Therefore, it is important to be able to detect disconnections and occlusions and to alert the respiratory therapist to these conditions. The present invention meets these needs.

SUMMARY OF THE INVENTION

Briefly, and in general terms, the present invention provides for a system and method for detecting disconnection

2

and occlusion of a tubing system in the patient circuit of a patient ventilator. Once a patient tubing disconnection has been determined, the ventilator can then open the exhalation valve, deliver an idle flow with 100% oxygen to the tubing system, disable breath triggering, and generate an alarm indicating disconnection. The system and method of the invention can also detect a reconnection of the tubing system, and initiate resumption of pressure supported inspiration. For occlusion detection, the pressure drop in the tubing system is determined by pressure sensors in the inspiratory and expiratory airways of the tubing system. The two pressure drop values are compared and a severe alarm will sound if the actual pressure drop exceeds the severe level. Once occlusion is detected, the ventilator can respond to protect the patient from over distension, and can monitor the tubing system for abatement of the occlusion in a pressure based occlusion status cycling mode. The ventilator can revert back to normal ventilation when either circuit occlusion or exhaust port occlusion are not detected.

In one currently preferred embodiment, the invention accordingly provides for a method for detecting disconnection [or occlusion] of a patient tubing system of a pneumatically driven, electronically controlled ventilator system [for providing] *used to provide* breathing gas to a patient [during the exhalation phase of a breath cycle, the exhalation phase having a plurality of control intervals, with each of the control intervals having a predetermined duration]. A method of the invention comprises the steps of [delivering a flow of breathing gas to a patient during an inspiratory phase of a breath cycle,] determining an onset of an exhalation phase of the breath cycle, [suspending gas flow delivery to the patient tubing system during the exhalation phase of the breath cycle,] and monitoring exhalation flow and pressure in the patient tubing system during a plurality of control intervals of the exhalation phase of the breath cycle to determine whether a condition indicating disconnection of the patient tubing system has occurred. The exhalation pressure in the patient tubing system is monitored during a plurality of control intervals of the exhalation phase of the breath cycle to determine whether a condition indicating occlusion of the patient tubing system has occurred; and a disconnection signal indicating disconnection of the patient tubing system is generated responsive to the exhalation flow and the pressure in the patient tubing system if the condition indicating occlusion of the patient tubing system has not occurred, and if the condition indicating disconnection of the patient tubing system has occurred.

In another currently preferred embodiment, the invention provides for a system for detecting disconnection [or occlusion] of a patient tubing system of a pneumatically driven, electronically controlled ventilator system [for providing] *used to provide* breathing gas to a patient [during the exhalation phase of a breath cycle, the exhalation phase having a plurality of control intervals, with each of the control intervals having a predetermined duration]. The system comprises [means for delivering a flow of breathing gas to a patient during an inspiratory phase of a breath cycle,] means for determining an onset of an exhalation phase of the breath cycle, [means for suspending gas flow delivery to the patient tubing system during the exhalation phase of the breath cycle,] and means for monitoring exhalation flow and pressure in the patient tubing system during a plurality of control intervals of the exhalation phase of the breath cycle to determine whether a condition indicating disconnection of the patient tubing system has occurred. The system may include means for monitoring exhalation pressure in the patient tubing system during a plurality of control

3

intervals of the exhalation phase of the breath cycle to determine whether a condition indicating occlusion of the patient tubing system has occurred, and means for generating a disconnection signal indicating disconnection of the patient tubing system responsive to the exhalation flow and the pressure in the patient tubing system if the condition indicating occlusion of the patient tubing system has not occurred, and if the condition indicating disconnection of the patient tubing system has occurred.

In a presently preferred embodiment, a disconnection alarm signal is generated, the exhalation valve is opened, an idle flow is delivered, and flow and pressure are monitored to determine whether a condition indicating reconnection of the patient tubing system has occurred. In another currently preferred embodiment, the resumption of flow of breathing gas to the patient tubing system is initiated during an inspiratory phase of a breath cycle if a condition indicating reconnection of the patient tubing system has occurred.

The invention also provides for a method for detecting occlusion of a patient tubing system of a pneumatically driven, electronically controlled ventilator system [for providing] *used to provide* breathing gas to a patient [during the exhalation phase of a breath cycle, the exhalation phase having a plurality of control intervals, each of the control intervals having a predetermined duration]. A method of the invention comprises the steps of delivering a flow of breathing gas to a patient during an inspiratory phase of a breath cycle, determining an onset of an exhalation phase of the breath cycle, [suspending gas flow delivery to the patient tubing system during the exhalation phase of the breath cycle.] *monitoring delivered flows and exhaled flows*; monitoring exhalation pressure in the patient tubing system during a plurality of control intervals of the exhalation phase of the breath cycle to determine whether a condition indicating occlusion of the patient tubing system has occurred; and generating occlusion, signal indicating occlusion of the patient tubing system responsive to the pressure in the patient tubing system if the condition indicating occlusion of the patient tubing system has occurred.

In another presently preferred embodiment, the invention provides for a system for detecting occlusion of a patient tubing system of a pneumatically driven, electronically controlled ventilator system [for providing] *used to provide* breathing gas to a patient [during the exhalation phase of a breath cycle, the exhalation phase having a plurality of control intervals, with each of the control intervals having a predetermined duration]. The system comprises means for delivering a flow of breathing gas to a patient during an inspiratory phase of a breath cycle, means for determining an onset of an exhalation phase of the breath cycle, [means for suspending gas flow delivery to the patient tubing system during the exhalation phase of the breath cycle.] *means for monitoring delivered flows and exhaled flows*, means for monitoring exhalation pressure in the patient tubing system during a plurality of control intervals of the exhalation phase of the breath cycle to determine whether a condition indicating occlusion of the patient tubing system has occurred, and means for generating an occlusion signal indicating occlusion of the patient tubing system responsive to the pressure in the patient tubing system if the condition, indicating occlusion of the patient tubing system has occurred.

[In a presently preferred embodiment, the invention also provides for generation of an occlusion signal indicating occlusion of the patient tubing system if the condition indicating occlusion of the patient tubing system has occurred.] In a currently preferred embodiment, an occlu-

4

sion alarm signal is generated, the exhalation valve is opened, an idle flow is delivered, and flow and pressure are monitored in an occlusion status cycling mode to determine whether a condition indicating abatement of occlusion of the patient tubing system has occurred. The invention also provides for initiation of the resumption of flow of breathing gas to the patient tubing system during an inspiratory phase of a breath cycle if a condition indicating abatement of occlusion of the patient tubing system has occurred.

These and other aspects and advantages of the invention will become apparent from the following detailed description and the accompanying drawings, which illustrate by way of example the features of the invention.

BRIEF DESCRIPTION OF THE DRAWINGS

FIG. 1 is a schematic diagram of the system for detecting disconnection and occlusion of a patient tubing system for a patient ventilator, according to the invention; and

FIG. 2 is a flow chart illustrating the occlusion status cycling mode of the system of the invention.

DETAILED DESCRIPTION OF THE PREFERRED EMBODIMENTS

Pressures in the tubing system of a patient ventilator can fall below a baseline pressure value during disconnections and occlusions of the tubing system, risking impairment of a patient's lung function, and possible collapse of the lung. Patient breathing circuit disconnections result in the patient receiving either no breathing gas or very little gas from the ventilator, and can interfere severely with maintenance of PEEP. Occlusions in the tubing system can also dangerously increase the work of breathing. It is therefore important to be able to detect disconnections and occlusions and to respond to these conditions.

As is illustrated in the drawings, which illustrate, by way of example, the invention, in a first embodiment, the invention provides for a method and system for detection of disconnection and occlusion of a patient tubing system of a pneumatically driven, electronically controlled ventilator system. Parameters used to detect patient tubing system disconnections include pressure and exhalation flow levels measured by the pressure and flow sensors located in the exhalation module during the first 200 msec of exhalation, the volume returned during the exhalation phase, the volume delivered during the previous inspiratory phase, and in pressure based ventilation, the desired flow level if the time limit is reached.

The system 10 for detecting disconnection and occlusion of the patient tubing system of a pneumatically driven, electronically controlled ventilator system 12 is illustrated schematically in FIG. 1. The patient 14 is connected by the tubing system 16 to receive breathing gas. The tubing system includes an exhalation line 18 and an inhalation line 20 connected to the patient by a patient wye 21. A pressure sensor 22 and a flow sensor 24 are connected to the exhalation line to monitor pressure and flow, respectively, of the breathing gas in the exhalation line, and a pressure sensor 26 is also connected to the inhalation line to monitor the pressure in the inhalation line. All inputs from the sensors are received by a microprocessor 28 which governs all of the microcomputer based functions of the ventilator system, and which controls activation of a disconnection alarm 30, and an occlusion alarm 32. The exhalation line is connected to an exhalation compartment 34, which also includes a pressure sensor 36 for monitoring pressure of breathing gas in the exhalation compartment. The ventilator

5

system includes a pressure control valve 40 controlling pressure of breathing gas delivered to the patient, and a safety valve 42, typically connected to the exhalation line, for relieving excessive pressure of the breathing gas in the tubing system.

In a first set of criteria, a condition indicating disconnection of the patient tubing system has occurred can be declared if, during a control interval, the pressure in the tubing system as sensed by a pressure sensor in the exhalation line of the tubing system falls [outside] within a [desired,] predetermined range, and exhalation flow is less than a desired, predetermined threshold, for a contiguous period of consecutive control intervals within a predetermined initial period of time following onset of an exhalation phase. In a preferred embodiment of the first set of criteria, the control interval is 5 msec., and all of the following three conditions must be met at some time during the first 200 msec. of an exhalation phase, for a contiguous period of 100 consecutive milliseconds:

If Pat_press(n) \geq -0.5 cmH₂O
 AND Pat_press(n) \leq 0.5 cmH₂O
 AND Dry_exh_flow(n) \leq 0.5 lpm

where Pat_press (n) is the pressure in the tubing system as sensed by a pressure sensor in the exhalation line of the tubing system during a control interval, and Dry_exh_flow (n) is the exhalation flow as measured by the exhalation flow sensor, compensated for the breathing gas mix and for humidity in the gas to represent dry conditions. Typically, an estimated amount of water vapor flow is removed from the initial flow measurement from the exhalation flow sensor Exh_flow. Then, the remaining dry flow is compensated for the expected gas mix (N₂, O₂).

However, even if all of the above conditions of the first set of criteria are met, the declaration of the patient tubing system disconnection is preferably deferred until a period of time has elapsed, in which it can be determined whether occlusion of the tubing system has occurred. In a presently preferred embodiment, this delay period is about 300 msec following the onset of exhalation, independent of the breath phase. Detection of a tubing occlusion is allowed to be declared first, since it is possible for a tubing occlusion to falsely generate all the patient tubing system disconnection conditions of the first criteria.

Patient tubing system disconnections will usually be detected based on the flow seen by the exhalation flow sensor and the Pat_press level, during the first 200 msec of any exhalation. In the vast majority of cases, the Pat_press level will be at or near zero cmH₂O of pressure, and since no communication exists between the ventilator's inspiration and exhalation ports, no flow will be detected by the exhalation flow sensor.

In a second set of criteria, a condition indicating disconnection of the patient tubing system has occurred can be declared if the pressure in the tubing system as sensed during a control interval by a pressure sensor in the exhalation line of the tubing system falls outside a desired, predetermined range, and exhalation flow is less than a disconnection flow limit threshold based upon a flow target and a predetermined disconnection sensitivity, for a contiguous period of consecutive control intervals within a predetermined initial period of time following onset of an exhalation phase. In a preferred embodiment of the second set of criteria, the control interval is 5 msec, and all of the following three

6

conditions must be met for a contiguous period of 10000 consecutive milliseconds, during the exhalation phase:

If Pat_press(n) \geq 0.5 cmH₂O
 AND Pat_press(n) \leq 0.5 cmH₂O

AND Dry_exh_flow(n) \leq disconnect_flow_limit
 where flow_target is the value of the ventilator's predetermined desired steady state flow delivery during the exhalation phase; disconnect_flow_limit is defined as flow_target*(1-disconnect_sensitivity/100), and if disconnect_flow_limit is less than 0.5 lpm, then disconnect_flow_limit is 0.5 lpm.

Disconnect_sensitivity is a setting, expressed in percent, that represents the percent of volume delivered in the previous inspiration, that was not returned (i.e., was lost) during the exhalation phase of the same breath. In a presently preferred embodiment, the range of disconnect_sensitivity is as follows:

20% \geq disconnect_sensitivity \geq 95%

In the case of a disconnection at the patient circuit inspiratory limb it is possible for the patient to generate flows in excess of 0.5 lpm and pressures outside the \pm 0.5 cmH₂O range of the first set of criteria, but is unlikely that these events will coincide with the first 200 msec of exhalation for long periods of time. This is the reason why the second set of criteria was developed.

When patient tubing system disconnections occur in a particular exhalation phase, they will usually be detected during a next exhalation, or if the disconnection does not cause autocycling of the ventilator, the disconnection can be detected during the current exhalation by the second set of criteria.

In a third set of criteria, a condition indicating disconnection of the patient tubing system has occurred can be declared if a desired flow target is greater than or equal to a maximum flow input to the flow controller, and the duration of a current inspiration is greater than or equal to a maximum allowed spontaneous inspiration time. This third set of criteria can be defined as follows:

If Desired_flow \geq Flow_cmd_limit
 AND Insp_time \geq Time_limit

where Insp_time is the duration of the current inspiration, Time_limit is the maximum allowed spontaneous inspiration time, and Flow_cmd_limit is the maximum flow input to the flow controller. For Pressure Based Ventilation (PBV), Flow_cmd_limit is dependent upon the patient type, and is typically 200 lpm for adult patients, and 80 lpm for pediatric patients.

The third set of criteria applies during the inspiration phase of a breath only, and only for spontaneous breaths, such as Continuous Positive Airway Pressure (CPAP) or Pressure support, for example.

The third set of disconnection detection criteria reflects the fact that if a true disconnection occurs, during Pressure Based Ventilation (PBV), the desired flow will be driven to the maximum command limit if enough time is allowed. This type of response is generated, even for the lowest pressure support level, if a total disconnection occurs at the beginning of the breath or during the previous exhalation, at any of the limbs or the endotracheal tube side of the wye. Thus this criteria fits very well for reconnection verification purposes, which will be discussed further below.

In a fourth set of criteria, a condition indicating disconnection of the patient tubing system has occurred can be declared if the exhalation volume is less than the integral of the net flow from the beginning of inspiration to the begin-

ning of exhalation with respect to time, multiplied by a proportional factor and a disconnection sensitivity factor, for three consecutive breaths. The fourth criteria can be defined as follows:

$$\text{Exh_vol} < \text{Insp_vol} * \text{proportional_factor} * (1 - \text{disconnect_sensitivity}/100) \quad 5$$

for three (3) consecutive breaths
where

$$\text{Inspvol} = - \int_{\text{BeginInsp}}^{\text{BeginExhal}} \text{NetFlow} * \delta t / 60 \quad (\text{Eq. 1}) \quad 10$$

$\text{Exh_vol} = \Sigma(\text{Net_flow} * \delta t / 60)$ if $\text{O_exh_finished} = 0$; and proportional_factor is defined by the pseudo code below: 15

If $\text{EIP-SOIP} \leq 0.1$

Then proportional_factor = 0

Else proportional_factor = $(\text{EIP} - \text{EPU}_0) / (\text{EIP} - \text{SOIP})$

where EIP = End of inspiration pressure; EPU_0 = End of exhalation pressure unfiltered at the time Q_exh_finished is set to 1; and SOIP (start of inspiration pressure) = value of P_we_unfiltered at the beginning of the current breath's inspiration. 20

P_we_unfiltered is calculated using the equation:

$$\text{P_we_estimate}_n = \text{MAX}(\text{P_we_imp_based_estimate}_n, \text{P_we_exh_based_eliminate}_n); \quad 25$$

where

$$\text{P_we_imp_based_estimate}_n = \text{Pat_press_imp_filtered}_n - \text{Ri} * (\text{Air_flow}_n + \text{O2_flow}_n). \quad 30$$

The term $\text{P_we_exh_based_estimate}_n$ is defined by the pseudo code below:

If $\text{Exh_flow} < 150$

The $\text{P_we_exh_based_estimate}_n = \text{Pat_press_filtered}_n - \text{Re} * \text{Exh_flow}_n$

Else $\text{P_we_exh_based_estimate}_n = \text{Pat_press_filtered}_n - \text{Re} * 150$

where:

$\text{Ri} = \text{Ri_slope} * (\text{Air_flow}_n + \text{O2_flow}_n) + \text{Ri_intercept}$

$\text{Re} = \text{Re_slope} * \text{Exh_flow}_n + \text{Re_intercept}$

Ri_slope = Slope for the inspiratory limb resistance equation 45

Ri_intercept = intercept for the inspiratory limb resistance equation

Re_slope = Slope for the expiratory limb resistance equation. 50

Re_intercept = intercept for the expiratory limb resistance equation.

Q_exh_finished is set to 0 (zero) at the beginning of exhalation and becomes 1 (one) the first time $\text{Net_flow_change_counter}$ is greater than 20 AND at least 200 msec of exhalation have elapsed or if the exhalation phase ends, whichever occurs first. Once Q_exh_finished is set to 1, it remains in this state until the beginning of the next exhalation phase. $\text{Net_flow_change_counter}$ is initialized to zero at the beginning of exhalation and incremented as indicated by the pseudo code below: 60

If $\text{Abs}(\text{Net_flow_filtered}_n - \text{Net_flow_filtered}_{n-1}) < 0.01 = \text{flow_target}$
AND $\text{Net_flow} \leq 0.2 + 0.08 = \text{flow_target}$

-continued

Then $\text{Net_flow_change_counter} = \text{Net_flow_change_counter} + 1$
Else $\text{Net_flow_change_counter} = 0$;

where:

flow_target = Value of the ventilator's predetermined desired steady state flow delivery during the exhalation phase. For pressure triggering mode of the value for flow_target is 1 lpm (Purge_flow). For flow triggering mode the value is Base_flow .

n = control interval initialized to zero at the beginning of exhalation

$\text{Net_flow_filtered}_n$ = Filtered Net_flow value. An alpha filter ($\alpha = 0.9$) is used to filter Net_flow .

$\text{Net_flow_filtered}_{-1}$ = Net_flow of last inspiration interval.

Insp_vol is initialized to 0 (zero) at the beginning of inspiration. Exh_vol is initialized to zero at the beginning of exhalation. The inequality in the criteria is tested only once, and always during the interval where Q_exh_finished is set to 1.

The fourth set of criteria enables the ventilation to also detect disconnections at the patient side of the endotracheal tube, since the volume returned will be much less than the volume delivered during a previous inspiration. A detection threshold setting, used by the therapist, is incorporated in the fourth set of criteria to avoid false disconnection detections generated by leaks in the patient lungs or the tubing circuit. Three consecutive breaths are needed for the fourth set of criteria for declaration of disconnecting to avoid false declarations when the patient "out-draws" the ventilator during volume ventilation. 35

Once any one set of criteria for declaring disconnection of the patient tubing system are met, the ventilator will open the exhalation valve, deliver an idle flow, such as typically a 5 lpm idle flow with 100% oxygen in the breathing gas mix, if possible, disable breath triggering, and generate an alarm indicating disconnection of the patient tubing. 40

Abatement of the condition of disconnection of the tubing system, or reconnection, will be detected when any one of the following conditions occurs:

- 1) If 80% of the idle flow is detected by the exhalation flow sensor as Q_{exh} (the exhalation flow compensated to dry flow) for 500 consecutive milliseconds; or
- 2) When both P_{insp} and P_{exh} read less than $-1.5 \text{ cmH}_2\text{O}$ for more than 100 consecutive milliseconds;
- 3) When both P_{insp} and P_{exh} read more than $1.0 \text{ cmH}_2\text{O}$ for more than 100 consecutive milliseconds; or
- 4) If P_{insp} reads more than $10 \text{ cmH}_2\text{O}$ for more than 100 msec, consecutively.

Upon detection of a reconnection, the ventilator will initiate delivery of a pressure supported inspiration (PSI), and will return to normal ventilation, typically using the settings in effect prior to the patient tubing system disconnection, once the inspiration phase of the PSI is over. Typically, the ventilator system will check for disconnection of the tubing system from the beginning of the PSI until the end of the exhalation following the PSI using all but the fourth set of criteria, and then using all criteria thereafter.

In another currently preferred embodiments, the invention also provides for a method and system for dynamically monitoring the pressure drop of the tubing system (i.e. including the patient airway tubing, bacteria filters, and humidifier system) of a pneumatically driven, electronically 65

controlled ventilator system for providing breathing gas to a patient during the exhalation phase of a breath cycle, with the exhalation phase having a plurality of control intervals, and each of the control intervals having a predetermined duration, for increases in pressure drop due to occlusions in the tubing system. Those skilled in the art will recognize that the predetermined duration of the control intervals may be fixed, and will also recognize that it may be advantageous to vary the control intervals according to sampling criteria established during operation of the ventilator, based upon performance of the ventilator while ventilating the patient. During ventilation, the pressure drop for a severe occlusion is computed based on the tubing type obtained, the delivered flows and the exhaled flows. The actual pressure drop is determined by comparing the pressure drop values from the inspiratory and expiratory pressure sensors, and an alarm indicating severe occlusion will be generated if the actual pressure drop exceeds a predetermined severe threshold level. The ventilator monitors the occlusion in a pressure based occlusion status cycling mode. This mode serves to protect the patient from over distension and to determine if the severe occlusion abates. The ventilator reverts back to normal ventilation when either tubing circuit occlusion or exhaust port occlusion are not detected.

The tubing pressure drop mathematical model (dP_{model}) can be expressed by a quadratic equation with flow as the independent variable, as follows:

$$dP_{model} = mA*Q^2 + B*Q + C \quad (\text{Eq. 2})$$

where A, B, C are constants and Q is the flow through the tubing. The constant C is zero since dP is zero when Q is zero. Therefore Eq. 2 becomes

$$dP_{model} = mA*Q^2 + B*Q \quad (\text{Eq. 3})$$

The remaining coefficients, A and B, can be obtained using a straight line fit of dP_{model}/Q :

$$dP_{model}/Q = A*Q + B \quad (\text{Eq. 4})$$

where A and B are constants to the straight line fit.

The quadratic pressure drop model (Eq. 3) is valid only for static measurements in flows. For dynamic flow rates, some errors are encountered in this model; but the model still serves as a good approximation of the pressure drop as a function of flow.

The actual or measured tubing circuit pressure drop, dP, is the difference between the inspiratory pressure sensor reading, P_{insp} , and the expiratory reading P_{exh} :

$$dP = P_{insp} - P_{exh} \quad (\text{Eq. 5})$$

For occlusion detection purposes Eq.5 is modified to account for the pressure and [low] flow sensor accuracies (i.e. offset & gain drift). The determination of dP is thus typically adjusted for such factors as offset and gain drift, based upon the following equation:

$$dP_{meas} = (P_{insp} - P_{exh}) - (0.7 + \text{Abs}(P_{insp}) * 0.062) \quad (\text{Eq. 6})$$

The pressure drop threshold for a severe occlusion is dependent upon the tubing classification as either adult or pediatric. Thus the pressure drop threshold for a severe occlusion, dP_{severe} , is defined for an adult patient by:

$$dP_{severe} = 0.005*Q^2 + 0.1491*Q + 0.0142 \quad (\text{Eq. 7})$$

and for a pediatric patient by:

$$dP_{severe} = 0.0082*Q^2 + 0.1431*Q + 0.136 \quad (\text{Eq. 8})$$

where Q is the flow in lpm causing the pressure drop to rise to a severe level. Since the location of the pressure drop increase is unknown, the maximum flow between Q_{insp} and Q_{exh} is used:

$$Q = \max[Q_{insp}, Q_{exh}] \quad (\text{Eq. 9})$$

The threshold dP_{severe} is typically limited to a minimum value of 5 cmH₂O to prevent false triggering of the alarm due to the usage of a Cascade Humidifier or due to the presence of water in the tubing circuit, and typically is limited to a maximum of 100 cmH₂O, since 100 cmH₂O is typically the maximum set wye pressure.

The actual or measured tubing circuit pressure drop, and the pressure drop threshold for a severe occlusion, dP_{severe} , for either an adult patient or a pediatric patient, is determined in every 5 ms cycle and are compared. If the measured pressure drop exceeds the pressure drop threshold for a severe occlusion for the prescribed durations discussed below, a severe occlusion alarm is annunciated and ventilation switches to an occlusion status cycling mode, discussed further below.

In one currently preferred embodiment, three independent time counters are used to monitor violations of a severe occlusion threshold depending on the magnitude of dP_{meas} . A violation occurs when dP_{meas} exceeds the threshold dP_{severe} . The three time counters are associated to dP_{meas} values that fall in the pressure ranges of >20, >10, and >5 cmH₂O respectively. Each counter is individually incremented if a violation occurs and if dP_{meas} is greater than the corresponding pressure range. If the condition for each counter is not met, then the counter is reset. Once the counters exceed 10, 20, and 40 cycles (i.e., for 50, 100, or 200 consecutive milliseconds) respectively, a severe occlusion alarm is annunciated.

The following pseudo code implements the above algorithm:

```

if (dPmeas > dPsevere)
{
  if (dPmeas > 20)
    t20-cm = t20-cm + 1;
  else
    t20-cm = 0;
  if (dPmeas > 10)
    t10-cm = t10-cm + 1;
  else
    t10-cm = 0;
  if (dPmeas > 5)
    t5-cm = t5-cm + 1;
  else
    t5-cm = 0;
}
else
{
  t5-cm = 0;
  t10-cm = 0;
  t20-cm = 0;
}
if (t5-cm > 40 OR t10-cm > 20 OR t20-cm > 10)
  severe_occlusion_detected = 1;

```

Occlusion of the exhalation exhaust port can also be detected from increases in the pressure drop of the exhalation compartment. The exhalation compartment includes those portions of the conduit downstream of the exhalation pressure transducer, including the heater manifold, flow sensor, exhalation valve, and any tubing attached to the exhalation outlet port. The amount of increase in pressure drop for the exhalation compartment is the same for a severe

11

occlusion defined for adult patients. This increase is typically given by

$$P_{increase} = 0.005 * Q^2 + 0.1491 * Q + 0.0142 \text{ tm (Eq. 10)}$$

where

$$Q = Q_{exh}$$

The exhaust port pressure threshold, $P_{exhaust_port_thresh}$ is calculated as the pseudo code below indicates.

If $P_{increase} < 1$

$$\text{Then } P_{exhaust_port_thresh} = 7.35 + PEEP + P_{exh} * 0.03 \quad (\text{Eq. 11})$$

$$\text{Else } P_{exhaust_port_thresh} = PEEP + P_{exh} * 0.03 + 6.35 \quad (\text{Eq. 12})$$

where $P_{exhaust_port_thresh}$ has an upper bound of 100 cmH₂O.

The exhalation pressure sensor measurement, P_{exh} , is compared to $P_{exhaust_port_thresh}$. If $P_{exh} > P_{exhaust_port_thresh}$ for 100 consecutive milliseconds, and 200 msec have elapsed in the exhalation phase, a seven occlusion alarm is annunciated and ventilation switches to the occlusion status cycling mode. It is commonly difficult to detect this type of occlusion during inspiration, and this mode of occlusion detection is disabled during exhalation pauses.

The maximum flow delivered from the ventilator is dependent upon patient type. The maximum flow limits (Flow_cmd_limit) for adult and pediatric patients are typically 200 and 80 lpm, respectively.

In a presently preferred embodiment, concurrently with the declaration of severe occlusion or the detection of exhalation exhaust port occlusion, the invention provides for a pressure-based occlusion status cycling mode. Occlusion status cycling serves two objectives: 1) protecting the patient from over distension while attempting to ensure that the patient receives some ventilation, and 2) monitoring the inspiratory and expiratory phases to determine if the severe occlusion abates. An occlusion status cycling ensues, the severe occlusion may relax to either a partial or a normal state. If an occlusion does abate, it must qualify as less than a severe before the ventilator system will revert to settings in effect prior to the patient tubing system occlusion. During occlusion status cycling, a purge flow is not to be established.

Referring to FIG. 2, the flow chart depicts the sequence of events that must be performed for the implementation of occlusion status cycling. Five phases of occlusion status cycling have been defined for the purpose of flow charting.

Phase 1: An exhalation phase in which the ventilator closes the pressure solenoid valves, controls the expiratory valve to zero PEEP, discontinuous flow triggering, sets PEEP equal to zero, sets the breathing gas oxygen percentage to 100, and opens the safety valve. This shut-down state persists until $P_{insp} \leq 5$ cmH₂O or until 15 seconds have elapsed, whichever occurs first. This phase is typically entered if an occlusion is detected while ventilating with normal settings.

Phase 2: An inspiration phase, in which at the beginning the ventilator closes the safety valve. After the 500 msec have elapsed, to allow for safety valve closure, the ventilator system delivers a Pressure Controlled Ventilation (PCV) based breath with an inspiratory pressure target of 15 cmH₂O, a flow acceleration percent of 100, an inspiratory time of (2500–500) msec., and using P_{insp} as the feedback signal for control.

Phase 3: An exhalation phase, in which the ventilator closes the pressure solenoid valves and controls the exhalation valve to zero PEEP. Exhalation will last until ($P_{insp} \leq 5$

12

cmH₂O AND at least 2.5 sec have passed) OR a total of 5 seconds have elapsed since the beginning of the exhalation.

Phase 4: An exhalation phase, in which the ventilator closes the pressure solenoid valves, controls the exhalation valve to zero PEEP and opens the safety valve. Exhalation will last until ($P_{insp} < 5$ cmH₂O AND at least 2.5 sec have passed) OR a total of 5 secs. have elapsed since the beginning of the exhalation

Phase 5: An inspiration phase with current mandatory settings, the only exception being PEEP which remains at zero. P_{exh} is used as the feedback signal for control purposes if the breathing algorithm is pressure based.

It will be apparent from the foregoing that while particular forms of the invention have been illustrated and described, various modifications can be made without departing from the spirit and scope of the invention. Accordingly, it is not intended that the invention be limited, except as by the appended claims.

What is claimed is:

[1. A method for detecting disconnection and occlusion of a patient tubing system of a pneumatically driven, electronically controlled ventilator system for providing breathing gas to a patient during the exhalation phase of a breath cycle, said exhalation phase having a plurality of control intervals, comprising the steps of:

delivering a flow of breathing gas to a patient during an inspiratory phase of a breath cycle;

determining an onset of an exhalation phase of said breath cycle;

suspending gas flow delivery to the patient tubing system during said exhalation phase of said breath cycle;

monitoring exhalation flow and pressure in the patient tubing system during a plurality of control intervals of said exhalation phase of said breath cycle to determine whether a condition indicating occlusion of the patient tubing system has occurred;

monitoring exhalation pressure in the patient tubing system during a plurality of control intervals of said exhalation phase of said breath cycle to determine whether a condition indicating occlusion of the patient tubing system has occurred; and

generating a disconnection signal indicating disconnection of the patient tubing system responsive to said exhalation flow and said pressure in said patient tubing system if said condition indicating occlusion of the patient tubing system has not occurred, and if said condition indicating disconnection of the patient tubing system has occurred.]

[2. The method of claim 1, wherein said tubing system includes an exhalation line, and said means for monitoring exhalation flow and pressure in the patient tubing system comprises sensing pressure and flow in said exhalation line, and declaring disconnection of the patient tubing system has occurred if, during a control interval, the pressure in the exhalation line is less than or greater than a predetermined pressure range, and if exhalation flow is less than a predetermined flow threshold, for a contiguous period of consecutive control intervals within a predetermined initial period of time following onset of an exhalation phase.]

3. [The method of claim 1,] A method for detecting disconnection of a patient tubing system of a pneumatically driven, electronically controlled ventilator system used to provide breathing gas to a patient, an exhalation phase of a breath cycle having a plurality of control intervals, comprising the steps of:

determining an onset of an exhalation phase of said breath cycle;

13

monitoring exhalation flow and pressure in the patient tubing system during a plurality of control intervals of said exhalation phase of said breath cycle to determine whether a condition indicating disconnection of the patient tubing system has occurred;

monitoring exhalation pressure in the patient tubing system during a plurality of control intervals of said exhalation phase of said breath cycle to determine whether a condition indicating occlusion of the patient tubing system has occurred; and

generating a disconnection signal indicating disconnection of the patient tubing system responsive to said exhalation flow and said pressure in said patient tubing system if said condition indicating occlusion of the patient tubing system has not occurred, and if said condition indicating disconnection of the patient tubing system has occurred;

wherein said tubing system includes an exhalation line, and said step of monitoring exhalation flow and pressure in the patient tubing system comprises sensing pressure and flow in said exhalation line, and declaring disconnection of the patient tubing system has occurred if, during a control interval, the pressure in the exhalation line is [less than or greater than] *within* a predetermined pressure range, and if exhalation flow is less than a disconnection flow limit threshold based upon a flow target and a predetermined disconnection sensitivity, for a contiguous period of consecutive control intervals within a predetermined initial period of time following onset of an exhalation phase.

[4. The method of claim 1, wherein said tubing system includes an exhalation line, and said step of monitoring exhalation flow and pressure in the patient tubing system comprises sensing flow in said exhalation line, and declaring disconnection of the patient tubing system has occurred if a desired flow target is greater than or equal to a maximum flow threshold, and the duration of a current inspiration is greater than or equal to a maximum allowed spontaneous inspiration time.]

5. [The method of claim 1,] *A method for detecting disconnection of a patient tubing system of a pneumatically driven, electronically controlled ventilator system used to provide breathing gas to a patient, an exhalation phase of a breath cycle having a plurality of control intervals, comprising the steps of:*

determining an onset of an exhalation phase of said breath cycle;

monitoring exhalation flow in the patient tubing system during a plurality of control intervals of said exhalation phase of said breath cycle; and

wherein said tubing system includes an exhalation line, and said step of monitoring exhalation flow and pressure in the patient tubing system comprises sensing flow in said exhalation line from beginning of an inspiration to the beginning of an exhalation, determining an exhalation volume from the sensed flow from the beginning of the inspiration to the beginning of the exhalation, and declaring disconnection of the patient tubing system has occurred if the exhalation volume is less than the integral of the net flow from the beginning of inspiration to the beginning of exhalation with respect to time, multiplied by a proportional factor and a disconnection sensitivity factor, for three consecutive breaths.

[6. The method of claim 1, wherein said tubing system includes an exhalation line and an inhalation line, and

14

wherein said means for monitoring exhalation pressure in the patient tubing system to determine whether a condition indicating occlusion of the patient tubing system has occurred comprises sensing pressure in said exhalation line, sensing pressure in said inhalation line, determining a pressure drop by comparing pressure in said exhalation line and pressure in said inhalation line, and generating an alarm indicating occlusion if said pressure drop exceeds a predetermined pressure drop threshold.]

[7. The method of claim 6, further including the step of adjusting said pressure drop for a pressure offset and a gain drift.]

[8. The method of claim 6, wherein said ventilator system includes a plurality of counters, each of said counters having a different limit corresponding to a different respective pressure drop range, said step of monitoring exhalation pressure in the patient tubing system to determine whether a condition indicating occlusion of the patient tubing system has occurred comprising comparing said pressure drop and said pressure drop threshold in a plurality of consecutive control intervals, and incrementing each of said plurality of counters if the pressure drop is greater than the corresponding pressure range of the plurality of counters, respectively, and generating an alarm if the respective limits of any of said plurality of counters are exceeded.]

[9. The method of claim 1, wherein said control intervals have a predetermine duration.]

[10. The method of claim 1, wherein said tubing system includes an exhalation compartment, and wherein said step of monitoring exhalation pressure in the patient tubing system to determine whether a condition indicating occlusion of the patient tubing system has occurred comprises sensing pressure in said exhalation compartment, and generating an alarm indicating occlusion if said pressure in said exhalation compartment exceeds a predetermined exhaust port threshold pressure for a predetermined number of consecutive control intervals within a predetermined period of time during an exhalation phase.]

[11. The method of claim 1, further comprising the step of generating an occlusion signal indicating occlusion of the patient tubing system if said condition indicating occlusion of the patient tubing system has occurred.]

[12. The method of claim 11, further comprising the steps of opening the exhalation valve, delivering an idle flow, and monitoring flow and pressure to determine whether a condition indicating abatement of occlusion of the patient tubing system has occurred.]

[13. The method of claim 11, wherein said ventilator system includes a pressure control valve and a safety valve, and breath support is flow triggered, and further comprising the steps of a shut-down phase of closing the pressure control valve, controlling the exhalation valve to maintain patient end expiratory pressure at approximately zero, discontinuing flow triggering, setting the patient end expiratory pressure equal to zero, setting the breathing gas mix to contain 100 percent oxygen, and opening the safety valve.]

[14. The method of claim 13, further comprising the step of initiating resumption of flow of breathing gas to the patient tubing system during an inspiratory phase of a breath cycle if a condition indicating abatement of occlusion of the patient tubing system has occurred.]

[15. The method of claim 13, wherein said tubing system includes an inhalation line, and further comprising the steps of sensing inspiratory pressure in said inhalation line, maintaining said shut-down phase until inspiratory pressure is less than or equal to 5 cmH₂O or until 15 seconds have elapsed, whichever occurs first; initiating an inspiration

15

phase, in which at the beginning the ventilator closes the safety valve, waiting a predetermined interval of time to allow for the safety valve to close, delivering a Pressure Controlled Ventilation based breath with an inspiratory pressure target of approximately 15 cmH₂O; initiating a first exhalation phase, in which the ventilator closes the pressure control valve and controls the exhalation valve to maintain a patient end expiratory pressure of approximately zero, until the inspiratory pressure is less than or equal to 5 cmH₂O and at least 2.5 sec have passed, or a total of 5 seconds have elapsed since the beginning of the first exhalation phase, initiating a second exhalation phase, in which the ventilator closes the pressure control valve, controls the exhalation valve to maintain a patient end expiratory pressure of approximately zero and opens the safety valve until the inspiratory pressure is less than or equal to 5 cmH₂O and at least 2.5 sec have passed, or a total of 5 seconds have elapsed since the beginning of the first exhalation phase; and initiating an inspiration phase with mandatory breath settings while maintaining patient end expiratory pressure of approximately zero.]

[16. The method of claim 1, further comprising the step of generating an occlusion alarm signal indicating occlusion of the patient tubing system if said condition indicating occlusion of the patient tubing system has occurred.]

[17. A system for detecting disconnection and occlusion of a patient tubing system of a pneumatically driven, electronically controlled ventilator system for providing breathing gas to a patient during the exhalation phase of a breath cycle, said exhalation phase having a plurality of control intervals, the system comprising:

means for delivering a flow of breathing gas to a patient during an inspiratory phase of a breath cycle;

means for determining an onset of an exhalation phase of said breath cycle;

means for suspending gas flow delivery to the patient tubing system during said exhalation phase of said breath cycle;

means for monitoring exhalation flow and pressure in the patient tubing system during a plurality of control intervals of said exhalation phase of said breath cycle to determine whether a condition indicating disconnection of the patient tubing system has occurred;

means for monitoring exhalation pressure in the patient tubing system during a plurality of control intervals of said exhalation phase of said breath cycle to determine whether a condition indicating occlusion of the patient tubing system has occurred; and

means for generating a disconnection signal indicating disconnection of the patient tubing system responsive to said exhalation flow and said pressure in said patient tubing system if said condition indicating occlusion of the patient tubing system has not occurred, and if said condition indicating disconnection of the patient tubing system has occurred.]

[18. The system of claim 17, wherein said tubing system includes an exhalation line, and said means for monitoring exhalation flow and pressure in the patient tubing system comprises a pressure sensor connected to said exhalation line and a flow sensor connected to said exhalation line, and means for declaring disconnection of the patient tubing system has occurred if, during a control interval, the pressure in the exhalation line is less than or greater than a predetermined pressure range, and if exhalation flow is less than a predetermined flow threshold, for a contiguous period of consecutive control intervals within a predetermined initial period of time following onset of an exhalation phase.]

16

[19. The system of claim 17, wherein said tubing system includes an exhalation line, and said means for monitoring exhalation flow and pressure in the patient tubing system comprises a pressure sensor connected to said exhalation line and a flow sensor connected to said exhalation line, and means for declaring disconnection of the patient tubing system has occurred if, during a control interval, the pressure in the exhalation line is less than or greater than a predetermined pressure range, and if exhalation flow is less than a disconnection flow limit threshold based upon a flow target and a predetermined disconnection sensitivity, for a contiguous period of consecutive control intervals within a predetermined initial period of time following onset of an exhalation phase.]

[20. The system of claim 17, wherein said tubing system includes an exhalation line, and said means for monitoring exhalation flow and pressure in the patient tubing system comprises a pressure sensor connected to said exhalation line, and means for declaring disconnection of the patient tubing system has occurred if a desired flow target is greater than or equal to a maximum flow threshold, and the duration of a current inspiration is greater than or equal to a maximum allowed spontaneous inspiration time.]

[21. The system of claim 17, wherein said tubing system includes an exhalation line, and said means for monitoring exhalation flow and pressure in the patient tubing system comprises a flow sensor connected to said exhalation line for measuring exhalation flow from the beginning of an inspiration to the beginning of an exhalation, means for determining an exhalation volume from the sensed flow from the beginning of the inspiration to the beginning of the exhalation, and means for declaring disconnection of the patient tubing system has occurred if the exhalation volume is less than the integral of the net flow from the beginning of inspiration to the beginning of exhalation with respect to time, multiplied by a proportional factor and a disconnection sensitivity factor, for three consecutive breaths.]

[22. The system of claim 17, wherein said tubing system includes an exhalation line and an inhalation line, and wherein said means for monitoring exhalation pressure in the patient tubing system to determine whether a condition indicating occlusion of the patient tubing system has occurred comprises a pressure sensor connected to said exhalation lines, a pressure sensor connected to said inhalation line, a comparator for determining a pressure drop by comparing pressure in said exhalation line and pressure in said inhalation line, and means for generating an alarm indicating occlusion if said pressure drop exceeds a predetermined pressure drop threshold.]

[23. The system of claim 22, further including means for adjusting said pressure drop for a pressure offset and a gain drift.]

[24. The system of claim 22, wherein said ventilator system includes a plurality of counters, each of said counters having a different limit corresponding to a different respective pressure drop range, said means for monitoring exhalation pressure in the patient tubing system to determine whether a condition indicating occlusion of the patient tubing system has occurred comprising a comparator for comparing said pressure drop and said pressure drop threshold in a plurality of consecutive control intervals, means for incrementing each of said plurality of counters if the pressure drop is greater than the corresponding pressure range of the plurality of counters, respectively, and means for generating an alarm if the respective limits of any of said plurality of counters are exceeded.]

[25. The system of claim 17, wherein said control intervals have a predetermined duration.]

17

[26. The system of claim 17, wherein said tubing system includes an exhalation compartment, and wherein said means for monitoring exhalation pressure in the patient tubing system to determine whether a condition indicating occlusion of the patient tubing system has occurred comprises a pressure sensor for measuring pressure in said exhalation compartment, and means for generating an alarm indicating occlusion if said pressure in said exhalation compartment exceeds a predetermined exhaust port threshold pressure for a predetermined number of consecutive control intervals within a predetermined period of time during an exhalation phase.]

[27. The system of claim 17, further comprising means for generating an occlusion signal indicating occlusion of the patient tubing system if said condition indicating occlusion of the patient tubing system has occurred.]

[28. The system of claim 17, further comprising means for opening the exhalation valve, means for delivering an idle flow, and means for monitoring flow and pressure to determine whether a condition indicating abatement of occlusion of the patient tubing system has occurred.]

[29. The system of claim 17, wherein said ventilator system includes a pressure control valve, a safety valve, and means for flow triggering breath support, and further comprising shut-down phase means for closing the pressure control valve, controlling the exhalation valve to maintain patient end expiratory pressure at approximately zero, discontinuing flow triggering, setting the patient end expiratory pressure equal to zero, setting the breathing gas mix to contain 100 percent oxygen, and opening the safety valve.]

[30. The system of claim 29, further comprising means for initiating a resumption of flow of breathing gas to the patient tubing system during an inspiratory phase of a breath cycle if a condition indicating abatement of occlusion of the patient tubing system has occurred.]

[31. The system of claim 29, wherein said tubing system includes an inhalation line, and further comprising occlusion status cycling means for sensing inspiratory pressure in said inhalation line, maintaining said shut-down phase until inspiratory pressure is less than or equal to 5 cmH₂O or until 15 seconds have elapsed, whichever occurs first; initiating an inspiration phase, in which at the beginning the ventilator closes the safety valve, waiting a predetermined interval of time to allow for the safety valve to close, delivering a Pressure Controlled Ventilation based breath with an inspiratory pressure target of approximately 15 cmH₂O; initiating a first exhalation phase, in which the ventilator closes the pressure control valve and controls the exhalation valve to maintain a patient end expiratory pressure of approximately zero, until the inspiratory pressure is less than or equal to 5 cmH₂O and at least 2.5 sec have passed, or a total of 5 seconds have elapsed since the beginning of the first exhalation phase; initiating a second exhalation phase, in which the ventilator closes the pressure control valve, controls the exhalation valve to maintain a patient end expiratory pressure of approximately zero and opens the safety valve until the inspiratory pressure is less than or equal to 5 cmH₂O and at least 2.5 sec have passed, or a total of 5 seconds have elapsed since the beginning of the first exhalation phase; and initiating an inspiration phase with mandatory breath settings while maintaining patient end expiratory pressure of approximately zero.]

[32. The system of claim 17, further comprising means for generating an occlusion signal indicating occlusion of the patient tubing system if said condition indicating occlusion of the patient tubing system has occurred.]

[33. A method for detecting occlusion of a patient tubing system of a pneumatic driven, electronically controlled

18

ventilator system for providing breathing gas to a patient during the exhalation phase of a breath cycle, said exhalation phase having a plurality of control intervals, comprising the steps of:

- 5 delivering a flow of breathing gas to a patient during an inspiratory phase of a breath cycle;
- determining an onset of an exhalation phase of said breath cycle;
- 10 suspending gas flow delivery to the patient tubing system during said exhalation phase of said breath cycle;
- monitoring exhalation pressure in the patient tubing system during a plurality of control intervals of said exhalation phase of said breath cycle to determine whether a condition indicating occlusion of the patient tubing system has occurred; and
- 15 generating a occlusion signal indicating occlusion of the patient tubing system responsive to said pressure in said patient tubing system if said condition indicating occlusion of the patient tubing system has occurred.]

[34. The method of claim 33, wherein said tubing system includes an exhalation line and an inhalation line, and wherein said step of monitoring exhalation pressure in the patient tubing system to determine whether a condition indicating occlusion of the patient tubing system has occurred comprises sensing pressure in said exhalation line, sensing pressure in said inhalation time, determining a pressure drop by comparing pressure in said exhalation line and pressure in said inhalation line, and generating an alarm indicating occlusion if said pressure drop exceeds a predetermined pressure drop threshold.]

[35. The method of claim 34, further including the step of adjusting said pressure drop for a pressure offset and a gain drift.]

[36. The method of claim 34, wherein said ventilator system includes a plurality of counters, each of said counters having a different limit corresponding to a different respective pressure drop range, said step of monitoring exhalation pressure in the patient tubing system to determine whether a condition indicating occlusion of the patient tubing system has occurred comprising comparing said pressure drop and said pressure drop threshold in a plurality of consecutive control intervals, and incrementing each of said plurality of counters if the pressure drop is greater than the corresponding pressure range of the plurality of counters, respectively, and generating an alarm if the respective limits of any of said plurality of counters are exceeded.]

[37. The method of claim 33, wherein said control intervals have a predetermine duration.]

[38. The method of claim 33, wherein said tubing system includes an exhalation compartment, and wherein said step of monitoring exhalation pressure in the patient tubing system to determine whether a condition indicating occlusion of the patient tubing system has occurred comprises sensing pressure in said exhalation compartment, and generating an alarm indicating occlusion if said pressure in said exhalation compartment exceeds a predetermined exhaust port threshold pressure for a predetermined number of consecutive control intervals within a predetermined period of time during an exhalation phase.]

[39. The method of claim 33, further comprising the step of generating an occlusion signal indicating occlusion of the patient tubing system if said condition indicating occlusion of the patient tubing system has occurred.]

[40. The method of claim 39, further comprising the steps of opening the exhalation valve, delivering an idle flow, and monitoring flow and pressure to determine whether a con-

dition indicating abatement of occlusion of the patient tubing system has occurred.]

[41. The method of claim 39, wherein said ventilator system includes a pressure control valve, a safety valve, and breath support is flow triggered, and further comprising the steps of a shut-down phase of closing the pressure control valve, controlling the exhalation valve to maintain patient end expiratory pressure at approximately zero, discontinuing flow triggering, setting the patient end expiratory pressure equal to zero, setting the breathing gas mix to contain 100 percent oxygen, and opening the safety valve.]

[42. The method of claim 41, further comprising the step of initiating resumption of flow of breathing gas to the patient tubing system during an inspiratory phase of a breath cycle if a condition indicating abatement of occlusion of the patient tubing system has occurred.]

[43. The method of claim 41, wherein said tubing system includes an inhalation line, and further comprising the steps of sensing inspiratory pressure in said inhalation line, maintaining said shut-down phase until inspiratory pressure is less than or equal to 5 cmH₂O or until 15 seconds have elapsed, whichever occurs first; initiating an inspiration phase, in which at the beginning the ventilator closes the safety valve, waiting a predetermined interval of time to allow for the safety valve to close, delivering a Pressure Controlled Ventilation based breath with an inspiratory pressure target of approximately 15 cmH₂O; initiating a first exhalation phase, in which the ventilator closes the pressure control valve and controls the exhalation valve to maintain a patient end expiratory pressure of approximately zero, until the inspiratory pressure is less than or equal to 5 cmH₂O and at least 2.5 sec have passed, or a total of 5 seconds have elapsed since the beginning of the first exhalation phase, initiating a second exhalation phase, in which the ventilator closes the pressure control valve, controls the exhalation valve to maintain a patient end expiratory pressure of approximately zero and opens the safety valve until the inspiratory pressure is less than or equal to 5 cmH₂O and at least 2.5 sec have passed, or a total of 5 seconds have elapsed since the beginning of the first exhalation phase; and initiating an inspiration phase with mandatory breath settings while maintaining patient end expiratory pressure of approximately zero.]

[44. The method of claim 33, further comprising the step of generating an occlusion alarm signal indicating occlusion of the patient tubing system if said condition indicating occlusion of the patient tubing system has occurred.]

[45. A system for detecting occlusion of a patient tubing system of a pneumatically driven, electronically controlled ventilator system for providing breathing gas to a patient during the exhalation phase of a breath cycle, said exhalation phase having a plurality of control intervals, each of said control intervals having a predetermined duration, the system comprising:

- means for delivering a flow of breathing gas to a patient during an inspiratory phase of a breath cycle;
- means for determining an onset of an exhalation phase of said breath cycle;
- means for suspending gas flow delivery to the patient tubing system during said exhalation phase of said breath cycle;
- means for monitoring exhalation pressure in the patient tubing system during a plurality of control intervals of said exhalation phase of said breath cycle to determine whether a condition indicating occlusion of the patient tubing system has occurred; and
- means for generating an occlusion signal indicating occlusion of the patient tubing system responsive to said

pressure in said patient tubing system if said condition indicating occlusion of the patient tubing system has occurred.]

[46. The system of claim 45, wherein said tubing system includes an exhalation line and an inhalation line, and wherein said means for monitoring exhalation pressure in the patient tubing system to determine whether a condition indicating occlusion of the patient tubing system has occurred comprises a pressure sensor connected to said exhalation line, a pressure sensor connected to said inhalation line, a comparator for determining a pressure drop by comparing pressure in said exhalation line and pressure in said inhalation line, and means for generating an alarm indicating occlusion if said pressure drop exceeds a predetermined pressure drop threshold.]

[47. The system of claim 46, further including means for adjusting said pressure drop for a pressure offset and a gain drift.]

[48. The system of claim 46, wherein said ventilator system includes a plurality of counters, each of said counters having a different limit corresponding to a different respective pressure drop range, said means for monitoring exhalation pressure in the patient tubing system to determine whether a condition indicating occlusion of the patient tubing system has occurred comprising a comparator for comparing said pressure drop and said pressure drop threshold in a plurality of consecutive control intervals, means for incrementing each of said plurality of counters if the pressure drop is greater than the corresponding pressure range of the plurality of counters, respectively, and means for generating an alarm if the respective limits of any of said plurality of counters are exceeded.]

[49. The system of claim 45, wherein said tubing system includes an exhalation compartment, and wherein said means for monitoring exhalation pressure in the patient tubing system to determine whether a condition indicating occlusion of the patient tubing system has occurred comprises a pressure sensor for measuring pressure in said exhalation compartment, and means for generating an alarm indicating occlusion if said pressure in said exhalation compartment exceeds a predetermined exhaust port threshold pressure for a predetermined number of consecutive control intervals within a predetermined period of time during an exhalation phase.]

[50. The system of claim 45, further comprising means for generating an occlusion signal indicating occlusion of the patient tubing system if said condition indicating occlusion of the patient tubing system has occurred.]

[51. The system of claim 50, further comprising means for opening the exhalation valve, means for delivering an idle flow, and means for monitoring flow and pressure to determine whether a condition indicating abatement of occlusion of the patient tubing system has occurred.]

[52. The system of claim 50, wherein said ventilator system includes a pressure control valve, a safety valve, and means for flow triggering breath support, and further comprising shut-down phase means for closing the pressure control valve, controlling the exhalation valve to maintain patient end expiratory pressure at approximately zero, discontinuing flow triggering, setting the patient end expiratory pressure equal to zero, setting the breathing gas mix to contain 100 percent oxygen, and opening the safety valve.]

[53. The system of claim 52, further comprising means for initiating a resumption of flow of breathing gas to the patient tubing system during an inspiratory phase of a breath cycle if a condition indicating abatement of occlusion of the patient tubing system has occurred.]

21

[54. The system of claim 52, wherein said tubing system includes an inhalation line, and further comprising occlusion status cycling means for sensing inspiratory pressure in said inhalation line, maintaining said shut-down phase until inspiratory pressure is less than or equal to 5 cmH₂O or until 15 seconds have elapsed, whichever occurs first; initiating an inspiration phase, in which at the beginning the ventilator closes the safety valve, waiting a predetermined interval of time to allow for the safety valve to close, delivering a Pressure Controlled Ventilation based breath with an inspiratory pressure target of approximately 15 cmH₂O; initiating a first exhalation phase, in which the ventilator closes the pressure control valve and controls the exhalation valve to maintain a patient end expiratory pressure of approximately zero, until the inspiratory pressure is less than or equal to 5 cmH₂O and at least 2.5 sec have passed, or a total of 5 seconds have elapsed since the beginning of the first exha-

22

lation phase; initiating a second exhalation phase, in which the ventilator closes the pressure control valve, controls the exhalation valve to maintain a patient end expiratory pressure of approximately zero and opens the safety valve until the inspiratory pressure is less than or equal to 5 cmH₂O and at least 2.5 sec have passed, or a total of 5 seconds have elapsed since the beginning of the first exhalation phase; and initiating an inspiration phase with mandatory breath settings while maintaining patient end expiratory pressure of approximately zero.]

[55. The system of claim 45, further comprising means for generating an occlusion alarm signal indicating occlusion of the patient tubing system if said condition indicating occlusion of the patient tubing system has occurred.]

* * * * *