



US00RE39100E

(19) **United States**
(12) **Reissued Patent**
Raming

(10) **Patent Number:** **US RE39,100 E**
(45) **Date of Reissued Patent:** **May 23, 2006**

- (54) **DUPLEX CARTON LABEL/PACKING LIST**
- (75) Inventor: **Bruce Raming**, Northbrook, IL (US)
- (73) Assignee: **Ward/Kraft, Inc.**, Ft. Scott, KS (US)
- (21) Appl. No.: **10/365,948**
- (22) Filed: **Feb. 13, 2003**

- 5,730,469 A * 3/1998 Heimerdinger et al.
- 5,893,512 A 4/1999 Diedrich
- 5,984,778 A 11/1999 Murphy
- 6,110,554 A 8/2000 Moeller et al.
- 6,213,518 B1 * 4/2001 Raming 283/67
- RE37,521 E 1/2002 Laurash et al.
- 2002/0193225 A1 * 12/2002 Raming 493/375

* cited by examiner

Primary Examiner—Monica S. Carter
(74) *Attorney, Agent, or Firm*—Hovey Williams LLP

Related U.S. Patent Documents

Reissue of:

- (64) Patent No.: **6,186,554**
- Issued: **Feb. 13, 2001**
- Appl. No.: **09/317,749**
- Filed: **May 24, 1999**

- (51) **Int. Cl.**
B42D 15/00 (2006.01)

- (52) **U.S. Cl.** **283/81**; 156/1; 156/253;
156/289; 229/74; 283/79; 283/101; 283/105;
428/41.8; 428/42.3; 428/43; 462/27

- (58) **Field of Classification Search** 283/81,
283/79, 80, 101, 103, 105; 229/74, 92.8;
428/41.8, 42.2, 42.3, 43; 462/26, 27; 156/1,
156/248, 249, 253, 289

See application file for complete search history.

- (56) **References Cited**

U.S. PATENT DOCUMENTS

- 3,315,387 A 4/1967 Heuser
- 4,368,903 A 1/1983 Jones
- 4,927,179 A 5/1990 Ehret et al.
- 4,928,875 A * 5/1990 Hutchinson
- 4,940,258 A 7/1990 Cuba, Jr. et al.
- 4,953,780 A 9/1990 Ross
- 5,289,972 A * 3/1994 Sauerwine et al.
- 5,370,420 A * 12/1994 Khatib et al.
- 5,413,383 A 5/1995 Laurash et al.
- 5,653,472 A 8/1997 Huddleston et al.

(57) **ABSTRACT**

A business form is provided which is particularly useful in shipping products where certain preprinted information can be provided and then individualized information is printed before the form is applied to a substrate. The form includes a face ply which has a pattern of adhesive applied to at least a portion of the inner face, and a release liner which includes a pattern of adhesive which exposes a portion of the release liner to direct adhesive contact to the face ply without intervening release coating to permanently adhere a part of the release liner to the face ply. The release liner has a surrounding protective border provided with release coating on the release face thereof and which is removed prior to application to the substrate, and a slip which remains with the form as applied to the substrate. The face ply includes lines of perforation defining a central portion. At least a part of the central portion is directly adhered by the adhesive to the slip without intervening release coating between the adhesive and the slip or the central portion. Individualized indicia, such as an address, may be printed on a label area of the top face of the central portion, while other individualized indicia, such as the content of a package, may be printed on the back face of the slip. Masking indicia is preferably provided on one of the inner face of the top ply or the release face of the release liner to inhibit viewing of the content indicia until the slip is removed from the package.

24 Claims, 5 Drawing Sheets

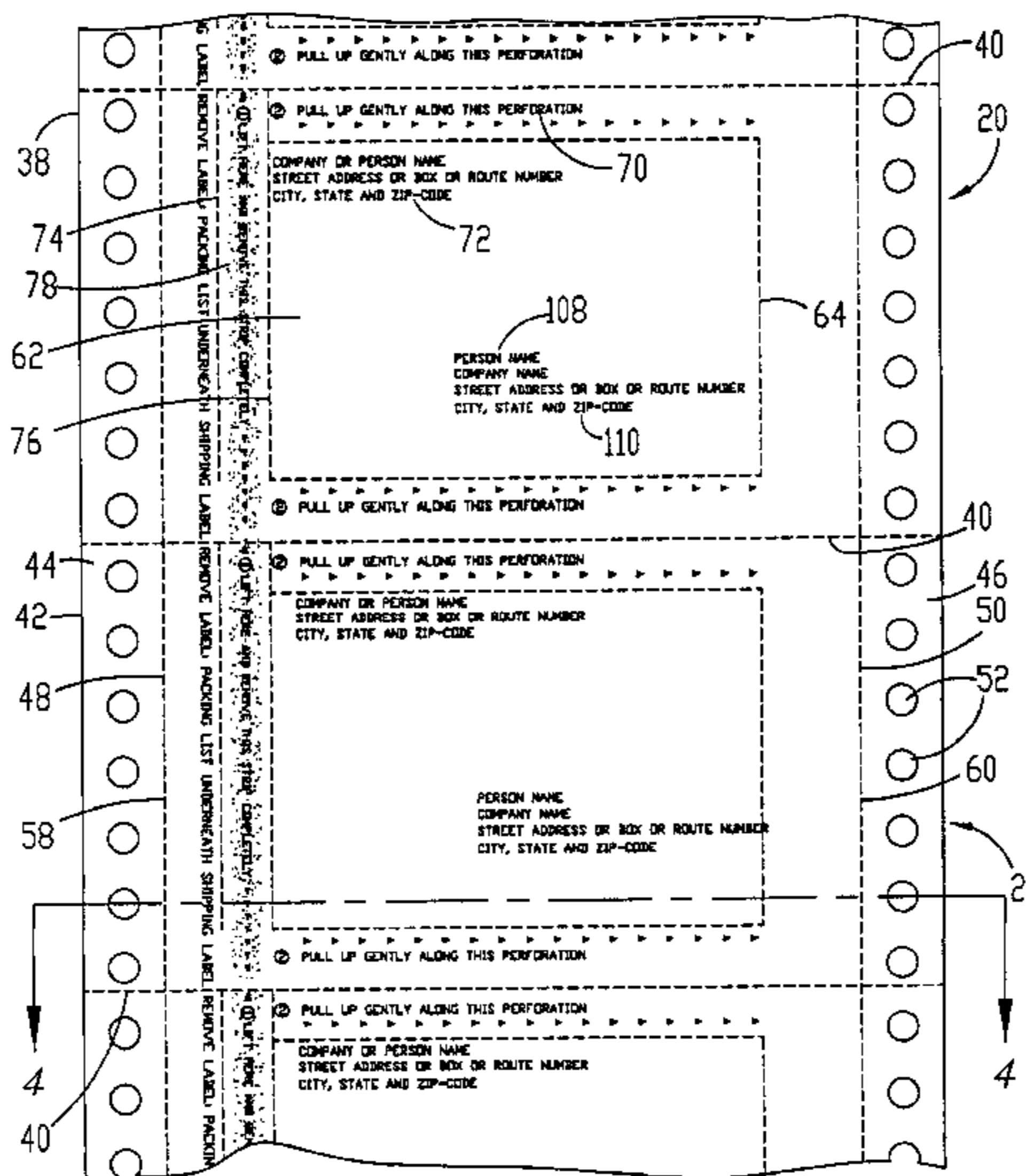

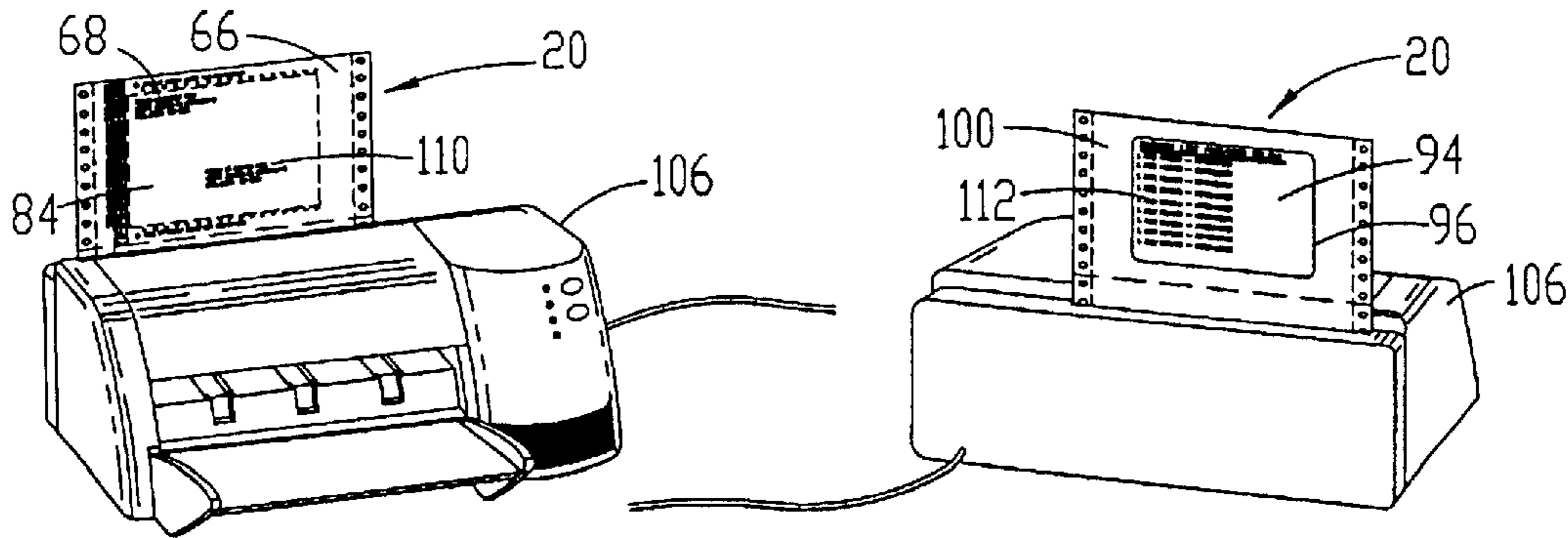
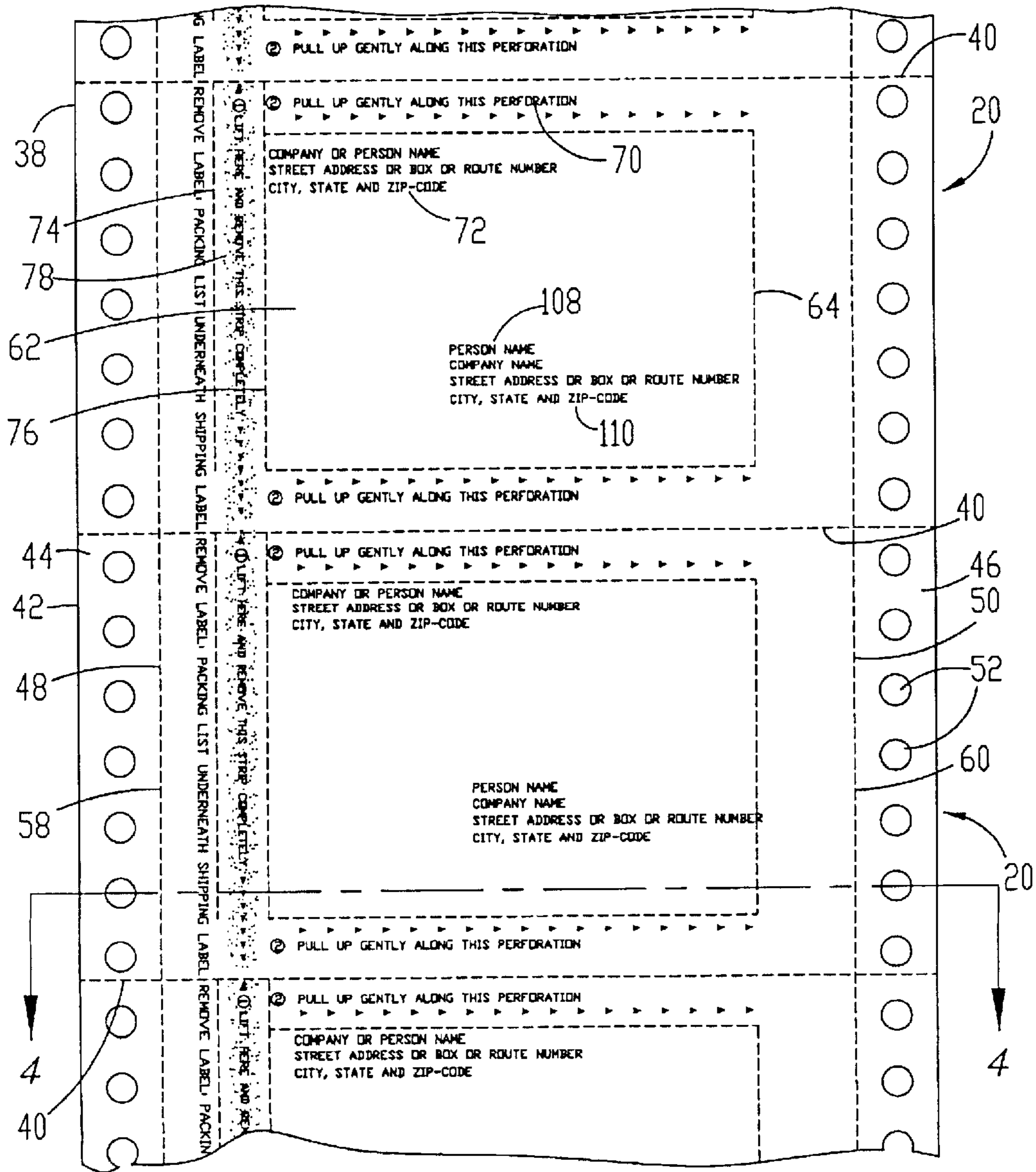

Fig. 1. Fig. 3. Fig. 2.



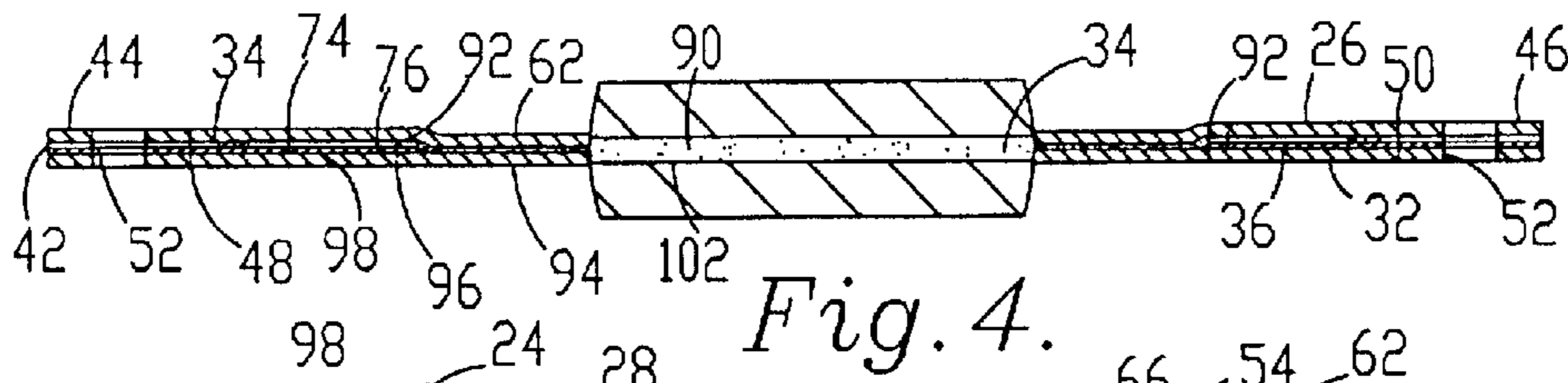

Fig. 4.

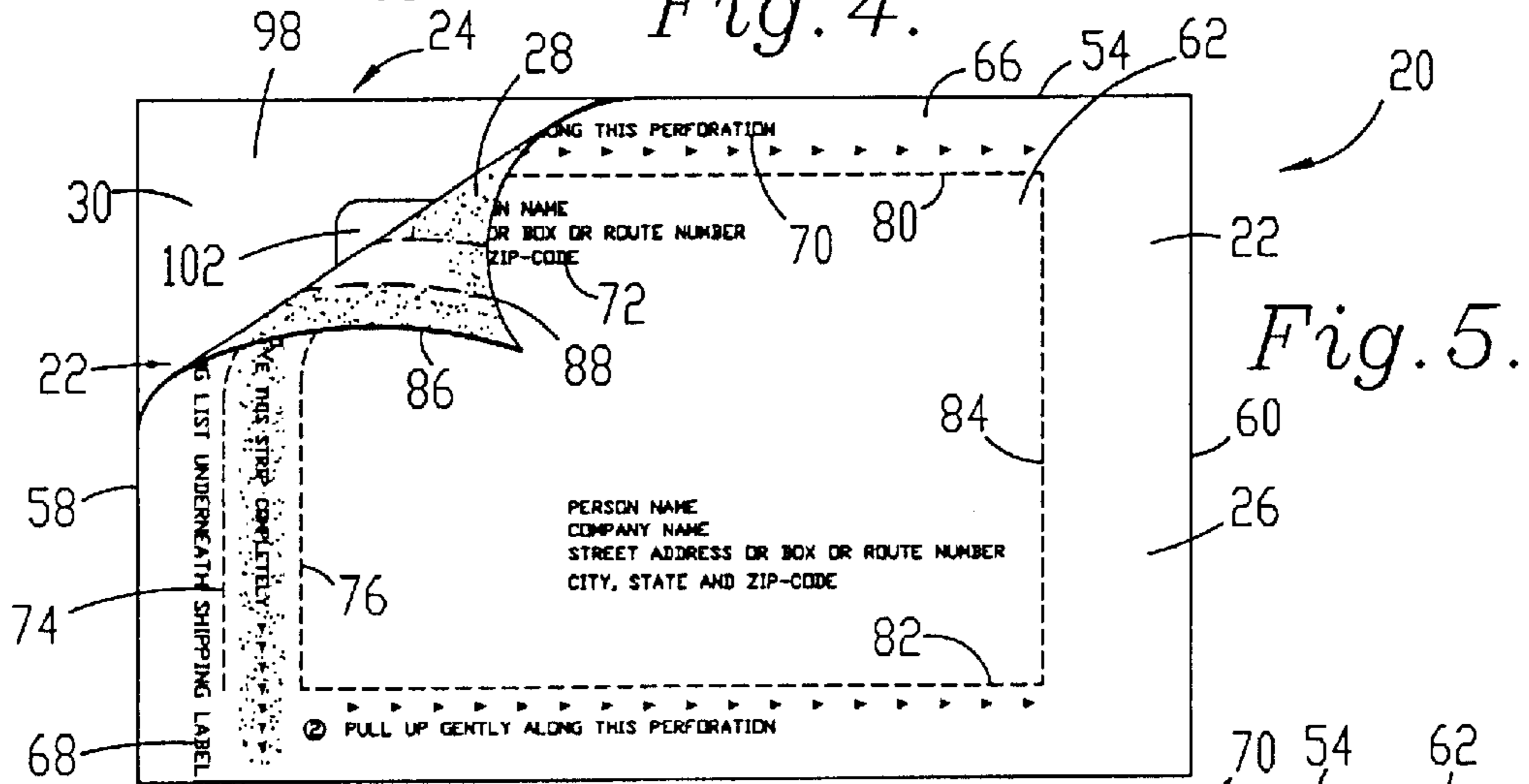

Fig. 5.

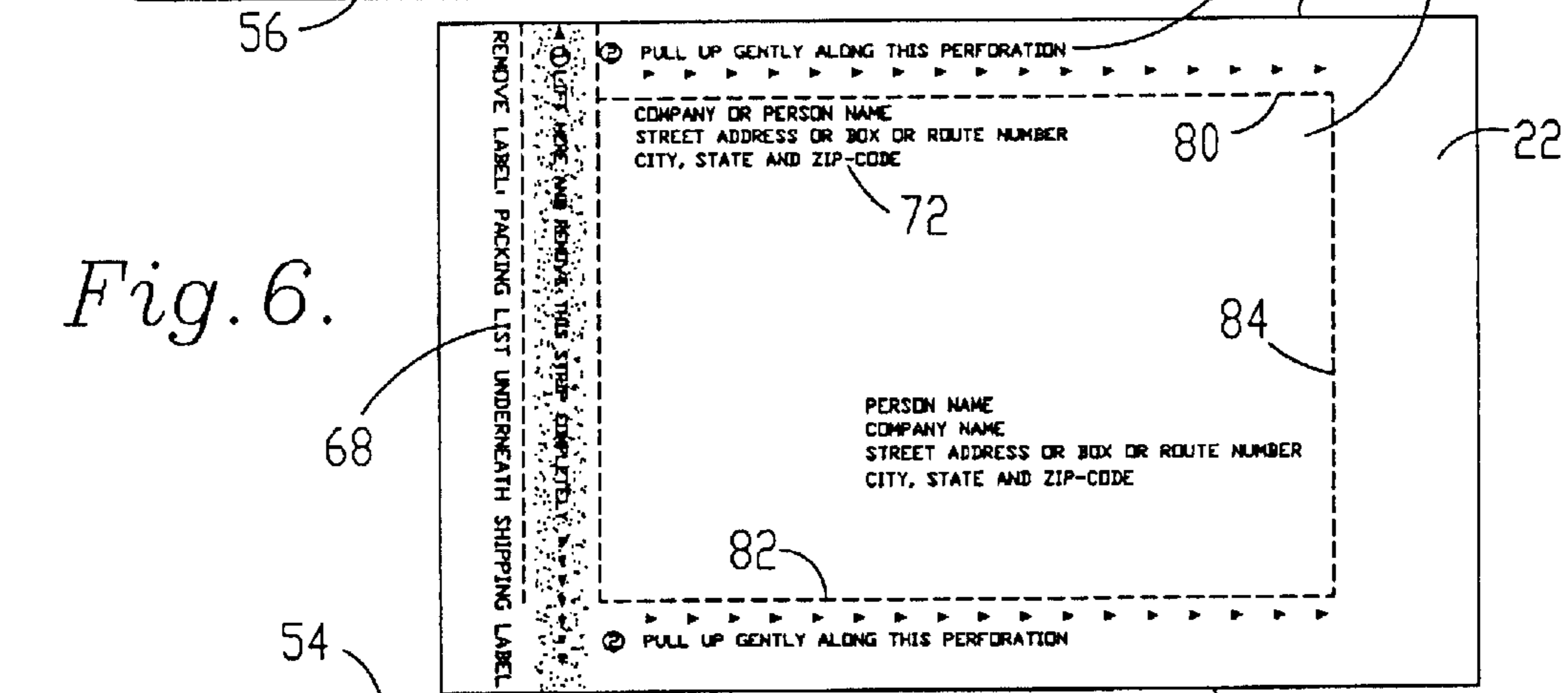

Fig. 6.

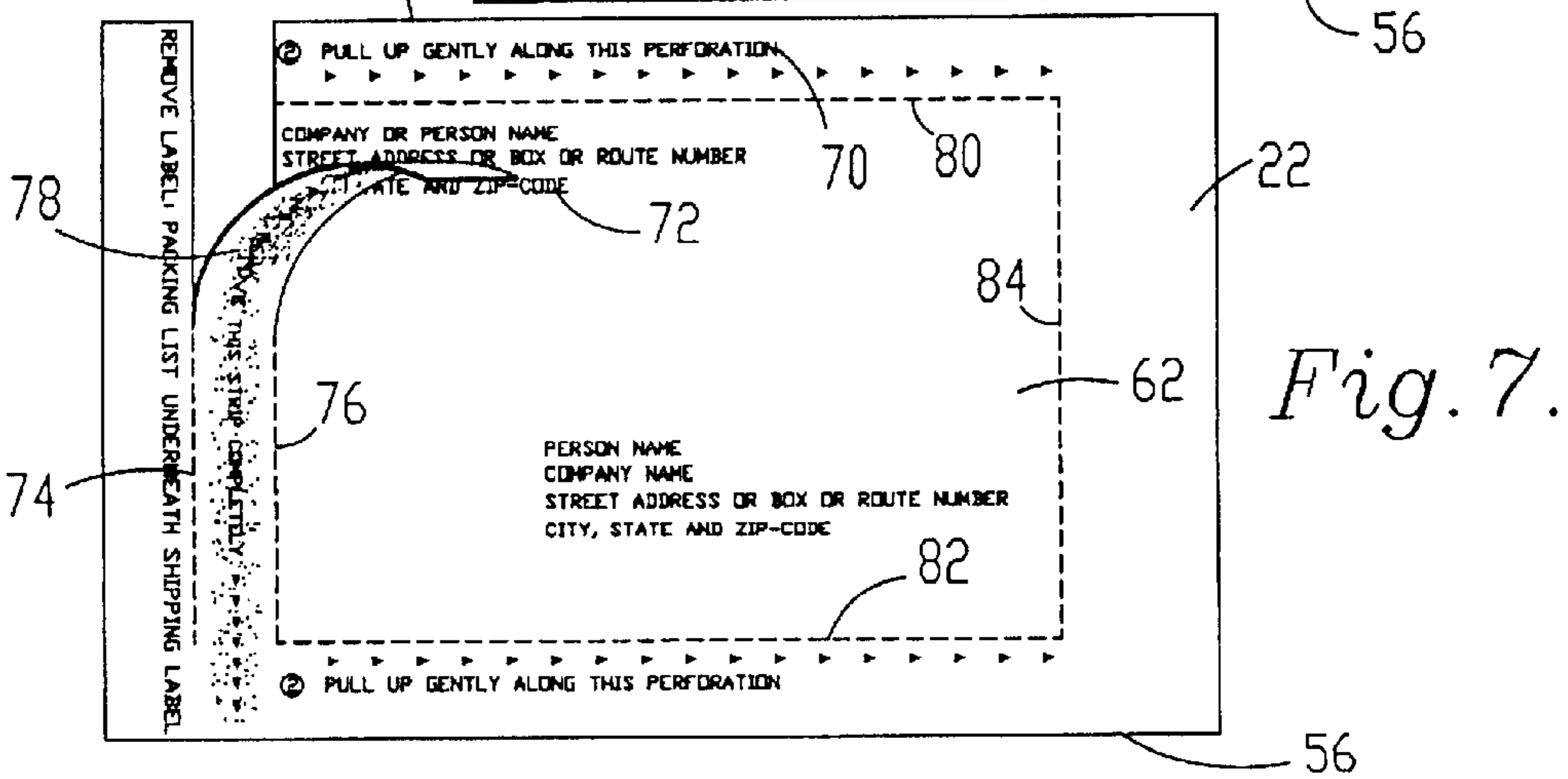

Fig. 7.

Fig. 8.

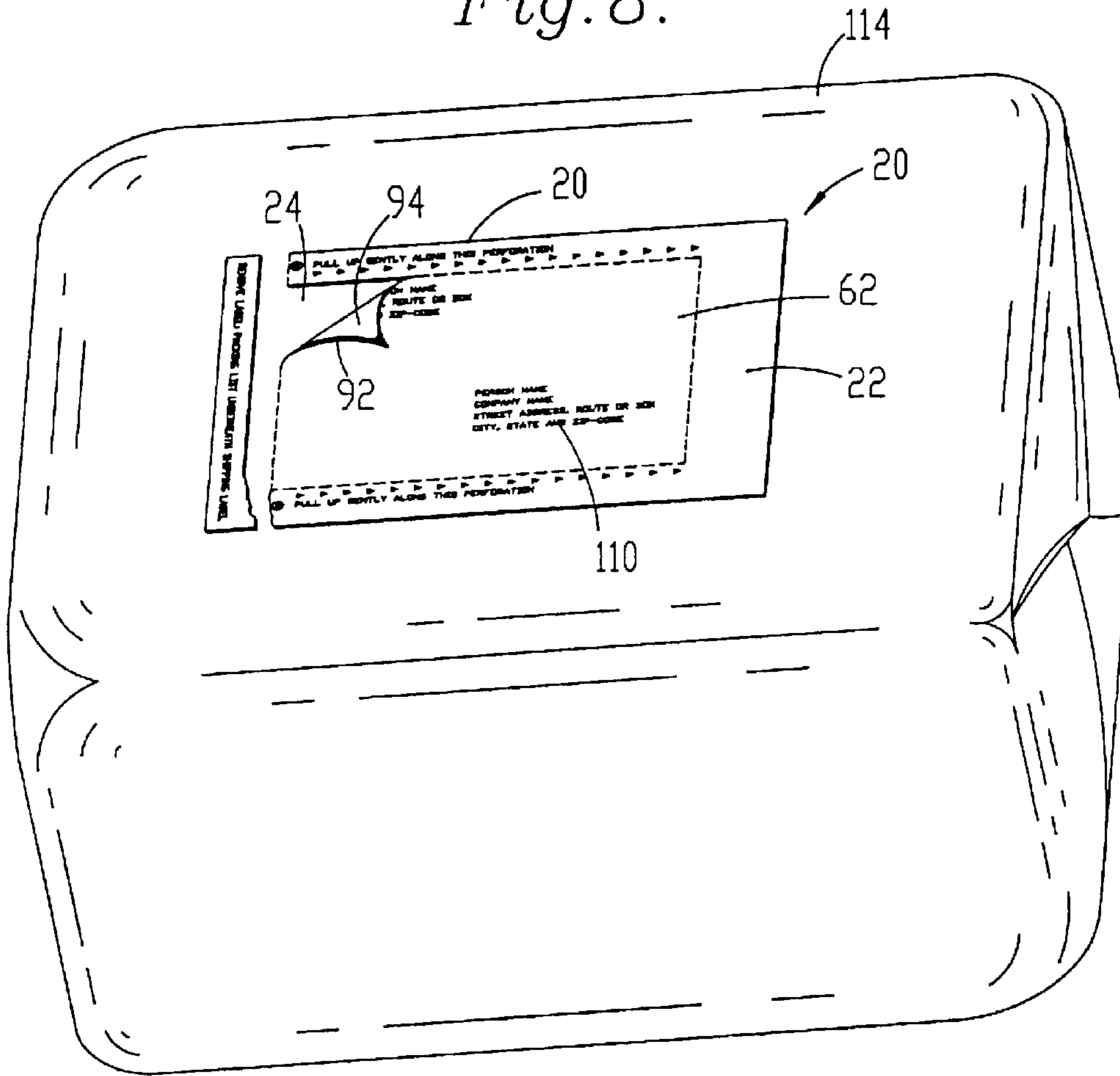
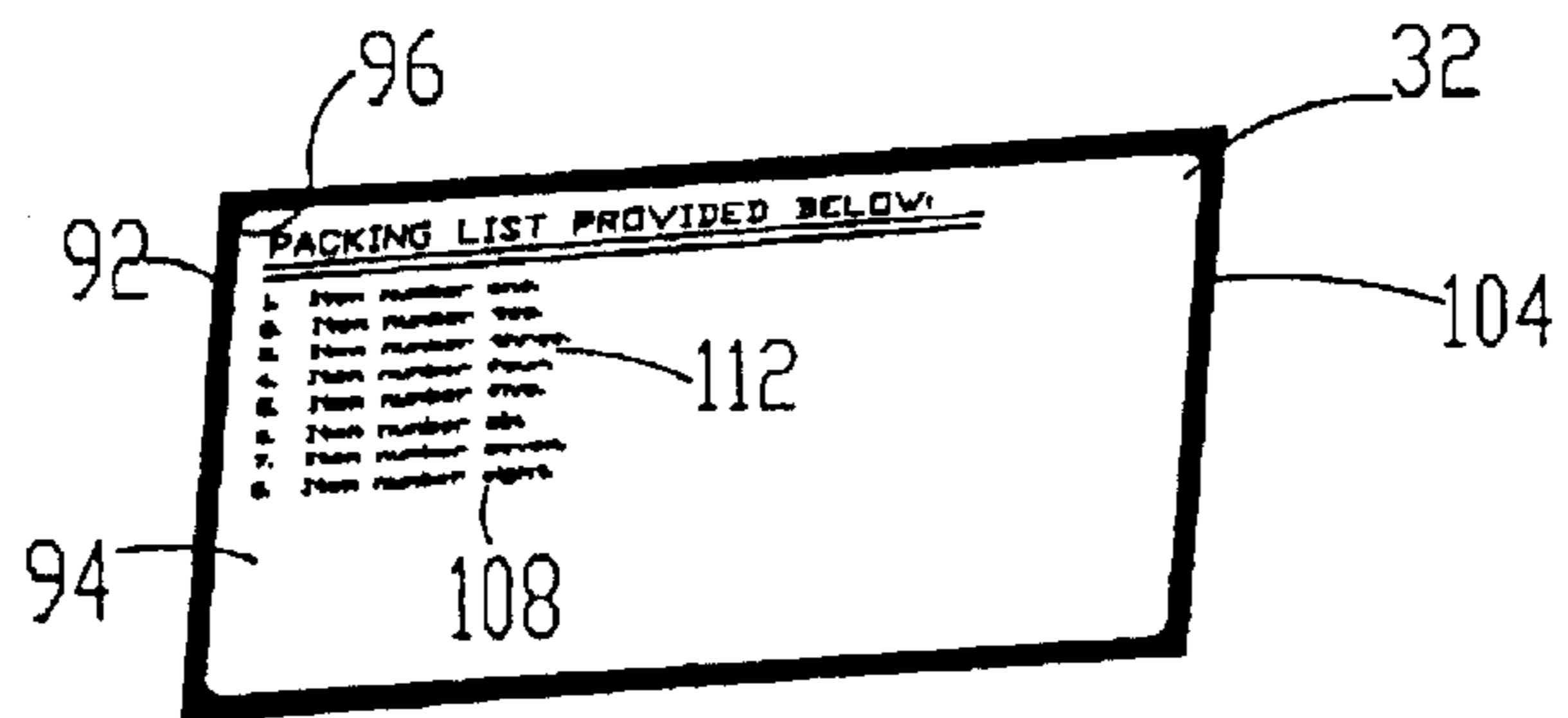

Fig. 9.



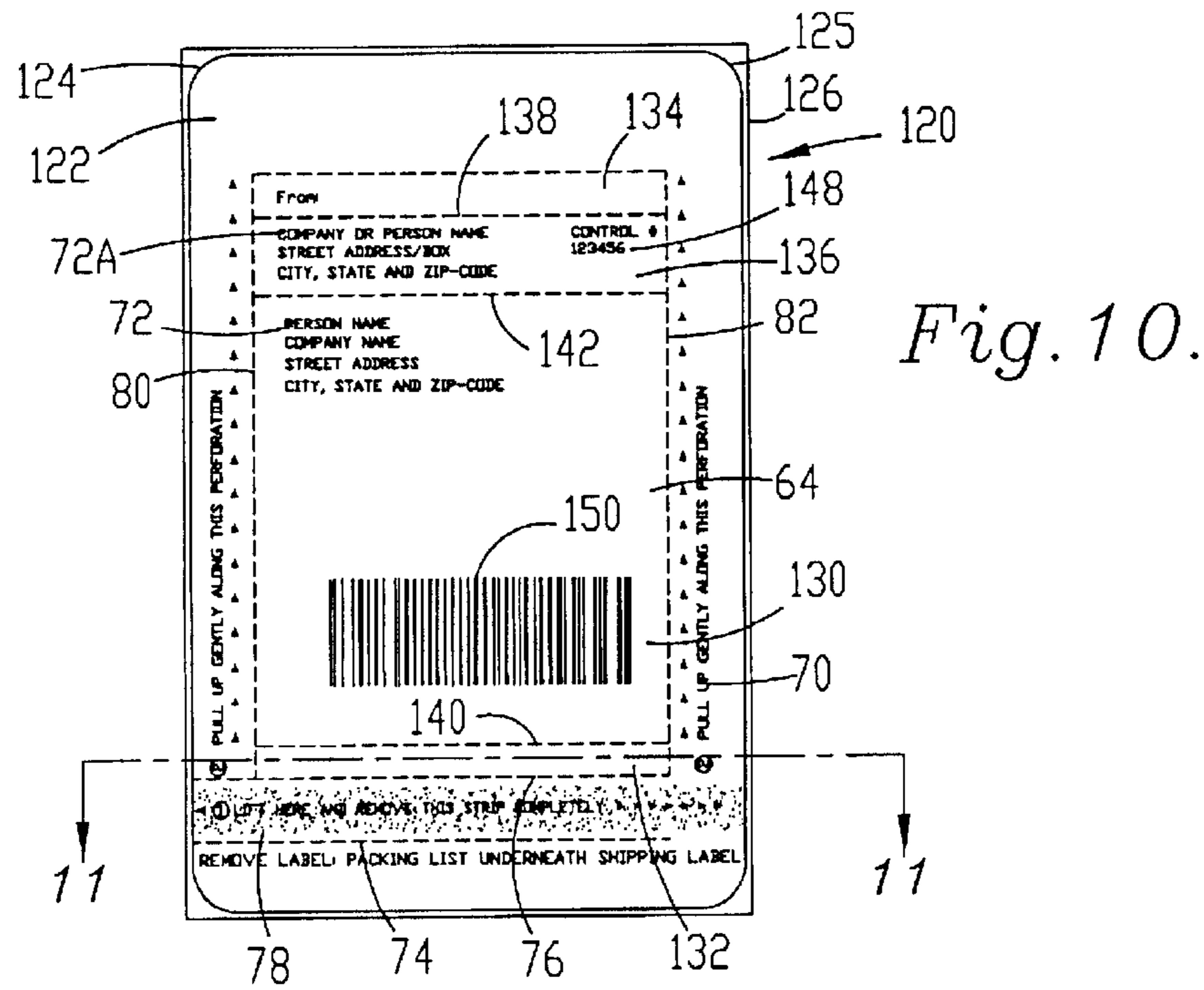

Fig. 10.

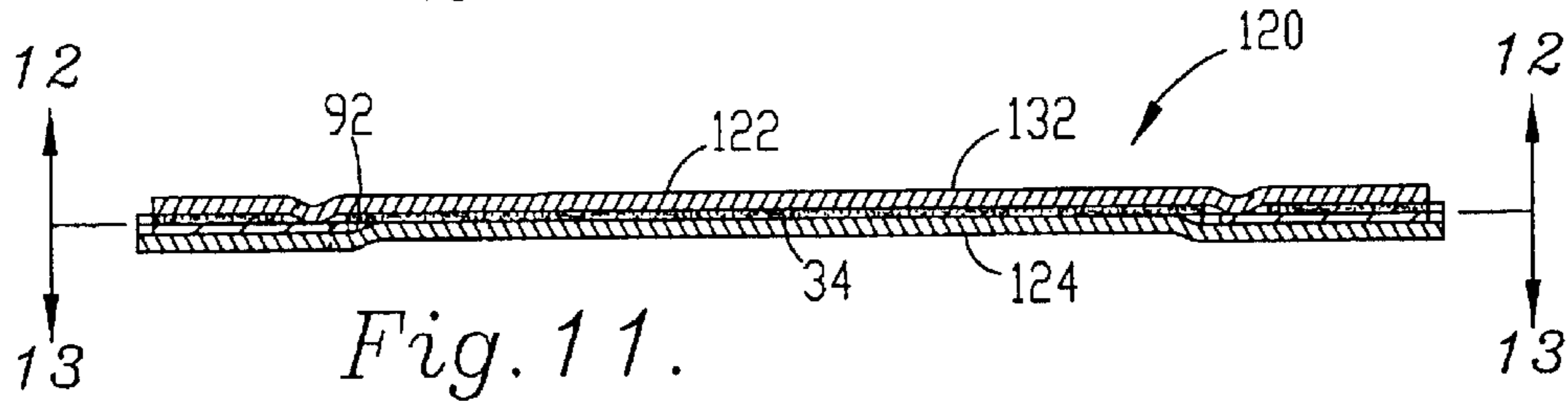

Fig. 11.

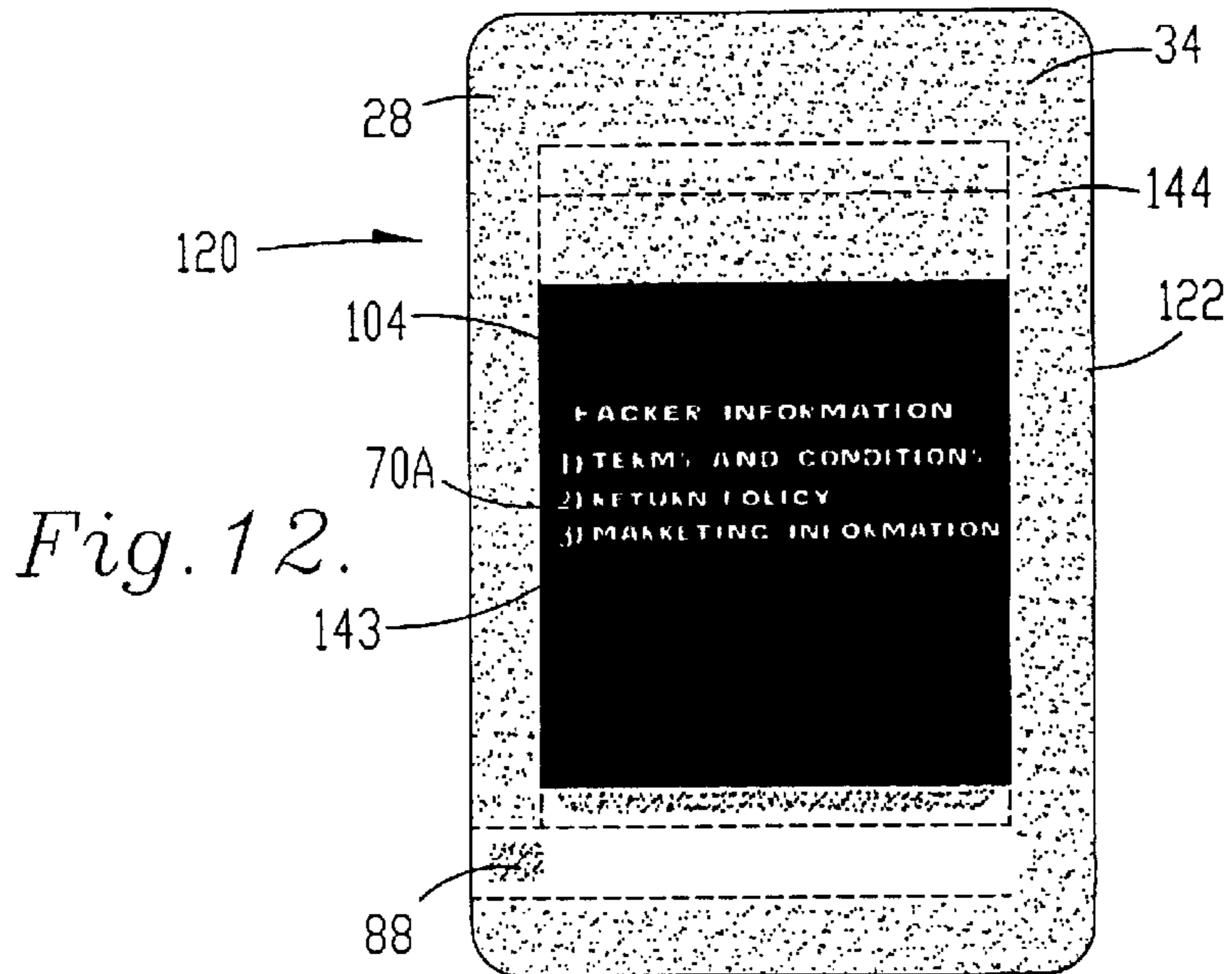

Fig. 12.

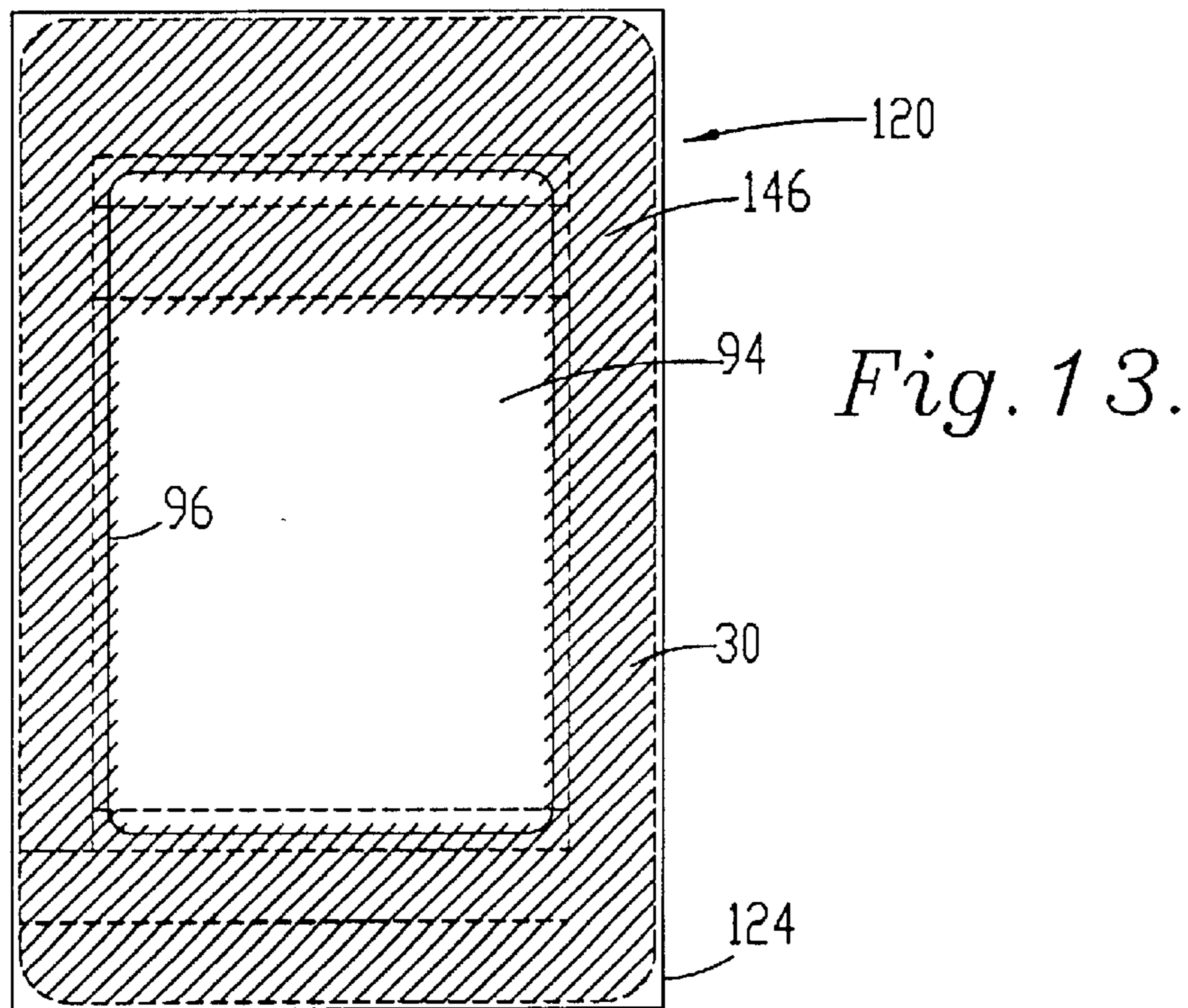

Fig. 13.

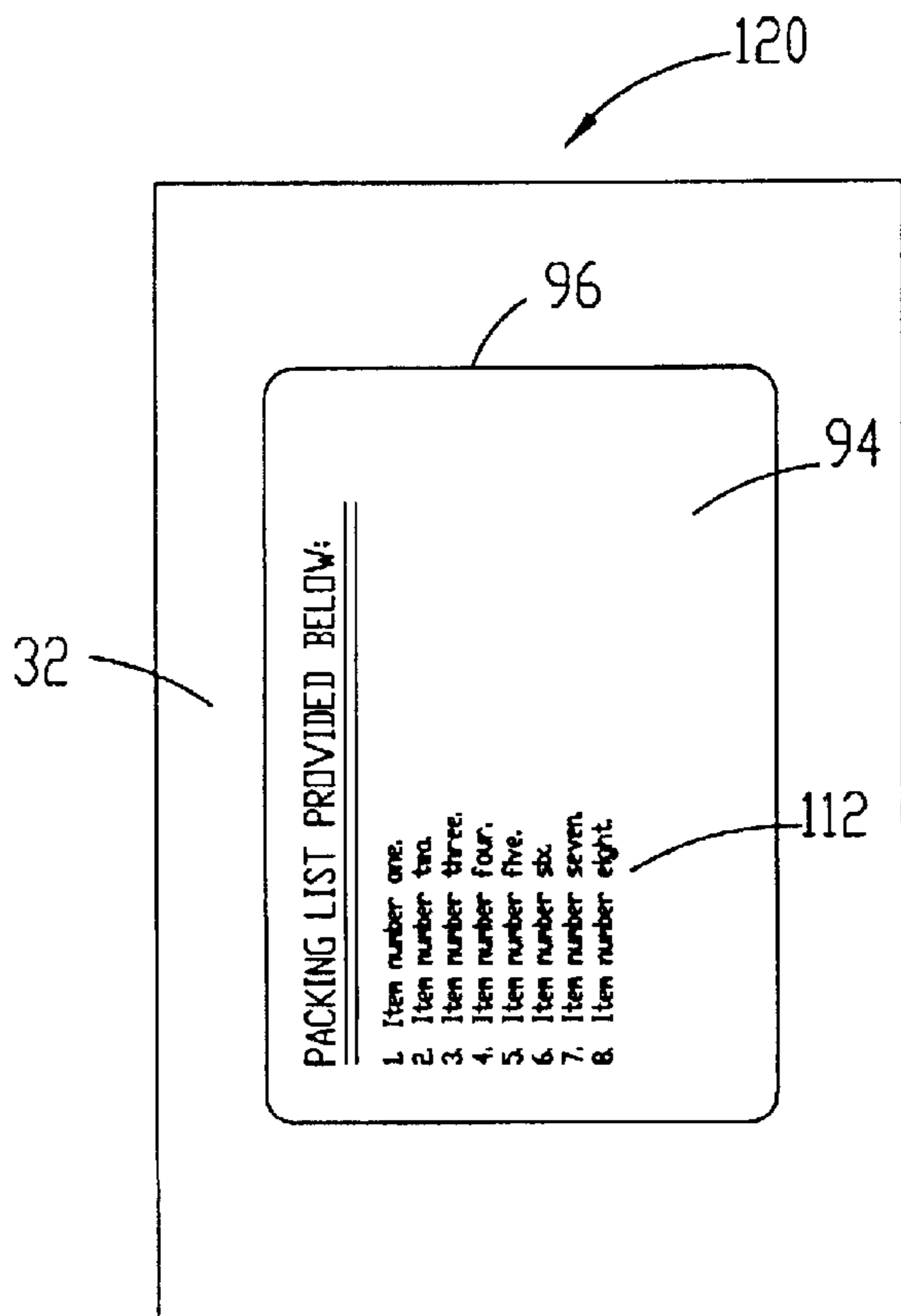

Fig. 14.

PACKING LIST PROVIDED BELOW:

- 1. Item number one.
- 2. Item number two.
- 3. Item number three.
- 4. Item number four.
- 5. Item number five.
- 6. Item number six.
- 7. Item number seven.
- 8. Item number eight.

DUPLEX CARTON LABEL/PACKING LIST

Matter enclosed in heavy brackets [] appears in the original patent but forms no part of this reissue specification; matter printed in italics indicates the additions made by reissue.

Notice: More than one reissue application has been filed for the reissue of U.S. Pat. No. 6,186,554. The reissue applications are 10/840,739 and 10/365,948 (the present application).

BACKGROUND OF THE INVENTION

1. Field of the Invention

This invention broadly concerns a business form adapted for receiving variable printing of information on both sides of the form as a subsequent attachment to a substrate. In one particular usage, it is more particularly concerned with a business form which may be used as a combination address label and packing list for use in shipping articles to a customer, and may include a return label portion.

2. Description of the Prior Art

The use of adhesive labels has become a growing segment of the business forms industry with the emergence of catalog sales and other home shopping vehicles. In addition to traditional wholesale shipments and delivery to commercial accounts, consumers increasingly elect to make purchases through telephone solicitations, through global computer networks, and catalogs. Shippers have thus looked for methods of increasing the efficiency of the shipping and handling process.

A variety of different labels have heretofore been developed for use in shipping products. These labels increasingly use ready to apply adhesives such as pressure sensitive adhesives, rather than adhesives which require wetting for activation, because of greater reliability of adhesion and ease of application. Such ready-to-use adhesives typically require the use of a coated liner to prevent premature adhesion, the liner being discarded as waste. However, with the increased need for security and efficiency in the shipping of packages, there has arisen a need for improved business forms which will minimize the number and size of the sheets in the form, while providing for selective adhesion to the underlying substrate and security in regard to the contents of the package, and also matches the shipping label and contents set forth on the packing list.

SUMMARY OF THE INVENTION

These needs have largely been met by the duplex carton label/packing list of the present invention. That is to say, the present invention provides a simple and economical business form which is easy to use, provides good adhesion to the underlying package or other substrate, limits waste, minimizes the number of sheets required in the form by performing multiple functions and provides good security by limiting the ability to view the packing list after application to the package. A portion of the liner sheet also functions as a packing list, thus limiting the number of plies necessary during manufacture and use. Moreover, the invention contemplates duplex printing of the liner in a single pass through a printer, so that both the addressee information and the packing list can be simultaneously printed on the form which is then ready to use. Lines of weakness and separation are provided in the face ply and release liner to permit access by the recipient to desired portions while the remainder stays affixed to the substrate. Adhesive is selectively applied in

patterns between the face ply and the backing ply to provide good adhesion to the substrate without overextending into the areas serving as the packing list.

Broadly speaking, the present invention includes a face ply having a top face and an inner face and a release liner having a release face which is pattern coated with silicone release liner to provide both coated and uncoated regions, and a printable back face. Adhesive, such as a pressure-sensitive adhesive, is applied in a pattern between the plies. Preferably, the patterning of adhesive and silicone release coating provides areas between the face ply and release liner which are free of both silicone coating and adhesive, and some areas which have adhesive only to provide permanent adherence between the plies. Lines of perforation or separation are preferably provided in the face ply to define a central portion which may be further divided by perforation lines for use as an address label, return label, or pull tabs, and a surrounding border portion for adhering to the substrate, as well as a tear strip for facilitating access to the central portion. The release liner may be provided with lines of perforation or separation to permit removal of the release liner in a surrounding border for adherence to the substrate, and a remaining packing label or list portion.

In preferred embodiments, the placement of the adhesive and silicone release can be varied to provide alternate configurations for the label. For example, in a first embodiment, the central label portion can be of double thickness by providing adhesive but not silicone release between the face ply and the release liner in the central label area. This yields a document suitable for filing and a more durable label which has greater tear resistance. In a second embodiment, the label portion may be divided by lines of perforation or severance so that a double thickness end tabs are provided, but single thickness address labels and return address labels are provided separate from a printable area on the release liner. It is desirable that one of the inner face and release face be printed with ink so as to cover and visibly screen the printing appearing on the printable back face of the liner to prevent viewing after application to the package without removal from the package.

The duplex carton label/packing list is easy to use. After preprinting each of the face ply and release liner as desired, applying the silicone liner and adhesive in the desired patterns, and making the appropriate perforation lines and lines of separation through perforation wheels or die cutting, for example, the forms, which are preferably provided as continuous webs separated into individual forms by transverse perforations, are ready for local use. The user inserts the form into an ordinary printer where no stylus is required. Most preferably, duplex printers for simultaneously printing both the back face and top face are used, although the form permits sequential printing of top face and back face. Thus, computerized information can quickly be printed giving both the recipient's address on the top face and the packing list on the back face. Either continuous feed or cut sheet versions can be used. The perimeter portion of the release liner is removed and the remainder of the form is then applied to the package, with the address visible on the top face. When the package arrives at the recipient, access is gained to the packing list by placing a finger under one edge at a designated location between the tear strip perforations and pulling on the tear strip. The central portion is then pulled free through die cuts on the release liner and perforations or other lines of weakness in the face ply, exposing the rear of the central portion as a packing list while the remainder of the form is adhered to the package.

As a result, high volumes of labels and packing lists can be generated as a single form, as a single pass through a

high-capacity duplex printer can generate and print the necessary information. As no carbon paper or other transfer media is employed to reprint the image on different plies, no stylus is necessary and ink-jet, laser or thermal-transfer printers may be used. The form can be preprinted with the exception of the individualized information to save time. Application of the address label and packing list to the package simply requires removal of the protective portion of the release liner, preferably located around the perimeter of the central area, and application to the package. This avoids the possibility that the packing list and address label will be separated and misapplied to different substrates. Upon receipt, the user grasps the tear strip which separates from the backing to allow the central area to be torn free and exposing the back face of the central area bearing the printing showing the contents or other information to be revealed to the recipient. The label is also tamper evident, such that the recipient can readily see tears to the form if others have sought access to the information on the back face.

The principal benefits and uses of the present invention will be readily apparent to those skilled in the art with reference to the following description and the drawings appended hereto.

BRIEF DESCRIPTION OF THE DRAWINGS

FIG. 1 is a front perspective view of the form of the present invention in a duplex computer printer;

FIG. 2 is rear perspective view of the form and printer shown in FIG. 1;

FIG. 3 is a front elevational view showing a continuous form of the present invention;

FIG. 4 is a sectional view along line 4—4 of FIG. 3, with a central area enlarged for clarity;

FIG. 5 is a front elevational view of a form separated from adjacent forms after individualized printing, with the protective portion of the release liner being separated to ready the form for application to a package or other substrate;

FIG. 6 is a front elevational view of the form of FIG. 5 as applied to a substrate;

FIG. 7 is a front elevational view of the form of FIG. 5 showing removal of the tear strip along perforations in the face ply for removal of the central portion;

FIG. 8 is a perspective view of the form of FIG. 5 after removal of the tear sheet and separation of the central packing list portion;

FIG. 9 is a rear elevational view of the central portion of the form of FIG. 5 after removal from the package to show the individualized packing list information;

FIG. 10 is a front elevational view of a second embodiment of the present invention, showing additional perforation lines in the face ply to provide segregated areas for pull tabs and return address labels thereon;

FIG. 11 is an enlarged cross-sectional view taken along line 11—11 to show the pattern application of adhesive and release coating between the face ply and the release liner and reverse printing to aid in masking the information on the release liner;

FIG. 12 is a view of the inner face of the face ply to show the pattern of adhesive applied to the face ply;

FIG. 13 is a view of the release face of the release liner showing the pattern of application release coating; and

FIG. 14 is a view of the back face of the release coating to show the packing label information thereon.

DESCRIPTION OF THE PREFERRED EMBODIMENT

Referring now to the drawing, a composite address label and packing list form **20** particularly suited for local duplex printing is shown in FIG. 3 and includes a face ply **22** and a release liner **24**. The face ply **22** has a top face **26** and an inner face **28** oriented toward the release liner **24**, and the release liner has a release face **30** oriented toward the face ply **22** and a back face **32**. Adhesive **34** and a silicone release coating **36** are applied in patterns between the face ply **22** and the release liner **24** to permit selected attachment of the face ply to the release liner in some areas and to facilitate separation in others. Printing as well as lines of perforations or full severance by cutting are provided in certain areas of the face ply **22** and release liner **24** to provide the form **20** hereof. Advantageously, some of the printing may be accomplished during manufacture, while other printing on the forms is individualized on a form-by-form basis.

It may be appreciated that the form **20** as shown in FIG. 3 is illustrated as a continuous web **38** of a connected series of forms **20** separated by cross-perforation lines **40** through both the face ply **22** and the release liner **24** into the individual forms **20**. This construction permits fan-folding of multiple forms and continuous feed during printing. When provided as a continuous web **38**, the forms **20** may initially include a control margin **42** along one or both longitudinal sides with feed strips **44** and **46** defined by longitudinally extending lines of weakening **48** and **50**, the feed strips **44** and **46** being provided with tractor feed holes **52**. However, the form **20** may also be provided in individual cut sheets rather than as a continuous web of connected forms, dispensing with the need for the feed strips **44**.

In greater detail, form **20** includes a top margin **54**, a bottom margin **56**, and side margins **58** and **60**. The face ply **22** includes a central portion **62** for functioning as an address label **64** and a surrounding border portion **66** positioned outboard of said central portion for attachment to a substrate such as a package as shown in FIG. 8. As used herein, "inboard" relates direction ally to the inner or central part of the form inwardly of the margins, while "outboard" refers directionally toward the area more proximate the margins. The face ply **22** may include preprinted indicia **68** including, for example, instruction indicia **70** for using the form **20** and identifying indicia **72** for identifying the sender. Spaced apart first and second tear strip perforation lines **74** and **76** are provided in the face ply **22** and extend from the top margin **54** almost to the bottom margin **56** to provide therebetween a tear strip **78**. Central portion **62** is defined within the top ply by tear strip perforation line **76** and by spaced-apart first and second transverse perforation lines **80** and **82** generally parallel to the top and bottom margins and by label perforation line **84** generally parallel to side margins **58** and **60**. Border portion **66** generally lies between the side margin **58** and tear strip **78**, and between top margin **54**, bottom margin **56**, and side margin **60** and central portion **62**.

Adhesive [54] **34** is strategically applied in a pattern between the face ply and the release liner. Preferably, the adhesive is a pressure sensitive adhesive, and is applied in a border pattern **86** on the inner face **28** of the face ply **22** beneath the border portion **66**, but preferably recessed about 1 mm outwardly from the perforation lines **74**, **80**, **82** and **84** to resist adhesive migration and undesired attachment between the face ply **22** and the release liner **24**. The border adhesive pattern **86** is not continuous in that part of the border portion **66** on the inner face **28** which is between tear

strip perforation lines **74** and **76** except for a patch **88** of adhesive shown in FIG. **5** to facilitate access to the tear strip **78** by the user but inhibit premature separation of the face ply **22** from the release liner **24**. A second, label adhesive pattern **90** is applied to the inner face of face ply **22** spaced interiorly of the perforation lines **76**, [**78**,] **80**, **82** and **84** to provide an adhesive free ring **92**. A packing slip **94** is provided by a die-cut line of separation **96** in the release liner. The adhesive-free ring preferably extends from about 1 mm outwardly of perforation lines [**78**,] **76**, **80**, **82** and **84** to about 1 mm inside the line of separation **96**, thus not only avoiding adhesive build up on cutting members during manufacture but also aiding in separation of the label and packing slip from the remainder of the form **20**. The adhesive **34** may be applied within adhesive patterns **86** and **90** in a continuous coating or as an intermittent coating to vary the amount of adhesion desired.

Silicone release coating **36** is applied over the release face **30** of the release liner in a release pattern **98**. The release pattern **98** preferably overlies the protective border **100** of the release liner **24** and extends slightly inboard of the line of separation **96**. However, at least a part of the release face **30** interiorly within the line of separation **96** is not included in the release pattern **98**, whereby direct adhesive connection is provided between the face ply **22** and the release liner **24** without any release coating therebetween. Preferably, this release-liner free area **102** is recessed about 1 mm interiorly of the circumscribing line of separation so that release coating is provided on the protective border **100** and across the line of separation **96**. As a result, the central portion **62** providing an address label of the face ply **22** is securely and substantially permanently bonded to the packing slip **94** in a two ply construction, with the remainder of the face ply **22** and release liner **24** outboard therefrom separable because any adhesive **34** on the face ply **22** contacts the release coating **36** and does not directly contact the release liner **24**.

Preferably, the preprinted indicia **68** includes a printed masking area **104** printed on the inner face **28**, or alternatively on the release face **30**. The indicia printed on form **20** to provide the masking area **104** is most preferably provided by ink or other visible coating which minimizes the transparency and translucency of the area to which it is printed. The printed indicia in the masking area **104** may be either continuous printing, as shown, or masking indicia as shown in U.S. Pat. No. 5,376,048 (the disclosure of which is incorporated herein by reference) as masking printing **31** or masking indicia **48**, and preferably covers more than 50% of the surface area within the line of separation **96**. That is to say, the actual ink coating is applied in a pattern or continuous coverage in the masking area effectively prevents viewing through the face ply **22** to see any printing on the back face **32** of the release liner **24**.

In use, the form **20** is fed through a printer **106** as shown in FIG. **1** and **2** whereby individualized indicia **108** is printed on each form **20**. While the top face **26** may be printed and the form **20** removed and reversed to present the base face **32**, the form **20** is most efficiently employed using a duplex printer **106** whereby in the same pass through the printer, individualized indicia in the form of address indicia **110** may be printed on the face ply **26** while at the same time content indicia **112** may be printed on the back face **32**. Because no transfer medium is employed, ink jet printers, laser printers, thermal printers or other non-stylus printers may be employed as well as typewriters, dot matrix, daisy wheel or other stylus-type printers.

After the individualized indicia **108** is printed, the protective border **100** is peeled away from the border portion **66** of the face ply **22** of form **20** as shown in FIG. **5**. This exposes the adhesive so that the form **20** may be securely

adhered to a substrate, such as a package **114** as shown in FIG. **8**. FIG. **6** shows the form **20** as applied to the package in FIG. **8**, and as may be seen in FIGS. **6** and **8**, the address label **64** presenting the address indicia **110** is clearly visible, while the content indicia **112** printed on the back face **32** is obscured from view. The construction and method of application substantially ensure a match between the intended recipient and list of contents, avoiding the possibility of mixing up an address label and a packing list because from the time of printing to application, the two are not separated or separable. This inhibits the likelihood of incurring the substantial costs and onerous tasks associated with mismatched labels and packages. Access to the back face **32** is only possible by tearing the tear strip **78** along tear strip perforation lines **74** and **76**, as shown in FIG. **7**. By tearing the tear strip **78** and then pulling up the central portion **62** along the perforation lines **80** and **82** as directed by the instruction indicia **70**, the recipient gains access to the address label **64** bonded to the packing slip **94**. The two plies of the bonded central portion **62** resist tearing and aid in maintaining the packing slip intact during tearing from the border portion. The recipient then need only tear along the label perforation line **84** to remove the packing slip **94** from the package **114**, and thereby review the information on the back face **32** as shown in FIG. **9**. Tampering is evidenced by tearing of the perforations **74**, **76**, **80**, **82**, or **84**, or around the border portion **66**.

A second embodiment is shown as form **120** and is in many respects similar in construction and use to form **20**. To the extent that elements referenced above with respect to form **20** are shown or described with respect to form **120**, the reference characters are the same. The form **120** shown in FIG. **10** is illustrated as a cut-sheet form but could also be provided as a continuous web of forms separated by cross-perforation lines and having feed strips as discussed with reference to form **20**.

Form **120** has a face ply **122** and a release liner **124**, wherein the face ply **122** has a surrounding margin **125** recessed interiorly of the perimeter **126** of the release liner **124** as shown in FIG. **10**. The provision of a recessed area [**128**] provides ease of separation of the protective border **100** during use of the form **120**. Additionally, the central portion **130** includes not only the address label **64** but also pull tabs **132** and **134** and a return label **136**, defined by pull tab perforation lines **138** and **140** and another release label perforation line **142** which are parallel to label perforation line **84** and extend between transverse perforation lines **80** and **82**.

Adhesive **34** is applied to the inner face **28** in an adhesive pattern **144** as shown by the shaded area in FIG. **12**. The adhesive pattern extends into the central portion but does not extend to the address label **64**, that is, the area bounded by perforation lines **80**, **82**, **140** and **142**, and preferably about a 1 to 2 mm adhesive-free area is provided between any adhesive and the perforation lines **80**, **82**, **84**, **140**, **142** and tear strip perforation lines **74** and **76**. The masking area **104** is shown as reverse printing indicia **143**, i.e. the printing within the masking area creates indicia by the absence of ink, whereby both masking of the content indicia **112** and additional preprinted instruction indicia **70a** may be provided on the face ply **122**. The masking area **104** is shown as only extending across inner face of the address label **64**, but it may be understood that the masking area could extend to the inner face of the return label **136**, the pull tabs **132** and **134**, or indeed the border portion **66** if desired.

FIG. **13** shows the release pattern **146** of release coating **36** applied to the release face **30** of the release liner **124**, with the dotted lines showing the margin and perforation lines of the face ply **122** for purposes of comparison and to show the registry between the face ply **122** and the release liner **124**.

The diagonal lines show the coverage of the release pattern 146, which may also extend about 1 mm across the die cut line of separation 96 if desired to assist in the separation of the packing slip 94 if the pattern of adhesive 144 is slightly misaligned, or outwardly to the perimeter of the release liner. As shown in FIG. 14, the back face 32 of the release liner 124 is provided with individualized indicia 108, such as the content indicia 112 shown. Form 120 permits the preprinted indicia 68 to include return address identifying indicia 72a and the additional preprinted instruction indicia 70a, as well as instruction indicia 70 and identifying indicia 72 as shown with reference to form 20.

Form 120 is made similarly to form 20 in that the face ply 122 and release liner 124 are initially printed with the preprinted indicia 68, adhesive is applied in the desired pattern 144 to the inner face 28 and release coating 36 is applied in the desired release pattern 146 either to the release face 30 or to the inner face 28 after the adhesive pattern 144 has been applied, and the face ply 122 is mated in registry to the release liner 124. The continuous web 38 of the mated face ply 122 and release liner 124 is then perforated through die cutting, perforation wheels or other conventional mechanisms, and the line of separation 96 is applied to the release liner 124 to provide the packing slip 94. As noted above, the continuous web 38 may be cross perforated or individual forms 120 provided by cutting into separate cut sheets as shown in FIGS. 10, 12, 13 and 14. FIG. 10 shows the use of a control number indicia 148 and a bar code indicia 150 to provide additional ease of internal accounting by the sender.

Form 120 is also used similarly to form 20. Individualized indicia 108 including address indicia 110 and content indicia 112 are respectively printed on the top face 26 and the back face 32 are printed by printer 106 at the time of use, preferably by using computerized information regarding the recipient. The protective border 100 is then peeled away so that the form 120 may be adhesively secured to a substrate, such as package 114, with the top face 26 bearing the address label 64 with instruction indicia 70 and identifying indicia 72 as well as address indicia 110 visible, but content indicia on back face 32 hidden and masked by masking area 104.

The recipient may grasp and pull the tear strip along tear strip perforation lines 74 and 76. Adhesive 34 directly contacts portions of the face ply 122 and release liner 124 within the pull tabs 132 and 133 without intervention of a release coating to provide two plies and reinforcement when the central portion 130 including the packing slip 94 are torn free from the border portion 66. However, in form 120, adhesive pattern 144 does not extend on the inner face 28 of the face ply 122 within the address label 64, so that the address label 64 may be separated along perforation lines 140 and 142 from the pull tabs 132 and 134 and thus also from the packing slip 94. This enables the instruction indicia 70a provided by the reverse printing within the masking area 104 to be visible to the recipient, thereby providing an additional printed surface as shown in FIG. 12 while retaining the reinforcement provided by the two-ply pull tabs 132 and 134 and the masking function inhibiting viewing of the content indicia 112 until the packing slip 94 is torn free.

Applicant has shown the form 20 as a continuous form with tractor feed strips and form 120 as a cut-sheet form. The particular manner of production is intended to illustrate examples, rather than limitations as to the size or whether multiple forms or continuous forms are attached to one another. For example, form 20 is readily useful without the tractor feed strips shown, either as a continuous form which may be fan-folded or provided on rolls, or as a cut-sheet form. As a cut sheet form, for example, form elements 20A and 20B may be provided on a single standard-sized 8.5 inch by 11 inch sheet without the need for feed strips 44 and 46

and separated by a cross-perforation line 20, although the size of the sheet is not intended to be limiting. Similarly, form 120 may be provided not as a single cut-sheet form, but also as a continuous form as shown with respect to form 20, which may be fan-folded or provided on a roll, or multiple forms 120 may be provided on a single sheet as described above.

Although preferred forms of the invention have been described above, it is to be recognized that such disclosure is by way of illustration only, and should not be utilized in a limiting sense in interpreting the scope of the present invention. Obvious modifications to the exemplary embodiments, as hereinabove set forth, could be readily made by those skilled in the art without departing from the spirit of the present invention. For example, the masking area 104 can be printed on either the inner face of the top ply or the release face of the release liner, and may extend beyond the central portion and across the border portion. The adhesive may be applied in a continuous coating or a pattern coating within the adhesive pattern depending on the degree of adhesion desired. It may also be appreciated that scoring or other weakening may be used in place of perforation lines to provide lines of weakening, and that such lines of weakening can be used in place of lines of separation. Additionally, the perforation lines need not be straight lines as shown, but can be arcuate or in other shapes as desired.

The inventor hereby states his intent to rely on the Doctrine of Equivalents to determine and assess the reasonably fair scope of his invention as pertains to any apparatus not materially departing from but outside the literal scope of the invention as set out in the following claims.

What is claimed is:

1. A business form for adhesive application to a substrate and for carrying publicly displayed indicia on one side and hidden indicia on a second, opposite side, said business form comprising:

a face ply having a top face and an inner face, a surrounding margin including a top margin, a bottom margin and first and second side margins, a tear strip defined by first and second generally parallel transversely extending lines of perforation between said first and second side margins and generally parallel thereto, and a separable central portion located between one of said tear strip lines of perforation and a label perforation generally parallel to said tear strip lines of perforation, and a pair of spaced apart transverse lines of perforation angularly oriented relative to said tear strip lines of perforation, said central portion including preprinted indicia on said top face, and a border portion generally surrounding said central portion;

indicia printed within said central portion of said top face;

a release liner having a release face and a back face, said release liner including a line of separation therein defining a centrally located slip area generally positioned beneath said central portion of said face ply and a protective border positioned generally beneath said border portion;

indicia printed within said slip area of said back face;

a layer of adhesive applied in a pattern between said inner face of said face ply and said release face of said release liner, said adhesive pattern including adhesive between at least a portion of said border portion and said protective border and adhesive between a part of said central portion and said release liner; and

a layer of release coating applied in a pattern between said inner face of said face ply and said release face of said release liner, said release pattern including release

coating between at least a portion of said border portion and said protective border, and including a release coating-free area between at least a part of said central portion and said release liner.

2. A business form as set forth in claim 1, wherein at least a portion of said pattern of release coating is applied intermediate a portion of said pattern of adhesive coating and said release liner.

3. A business form as set forth in claim 2, wherein a majority of said slip area of said release face of said release liner is not covered with release coating and contacts said adhesive of said adhesive pattern.

4. A business form as set forth in claim 2, wherein said tear strip of said face ply relatively inboard of said transverse lines of weakening is not covered on its inner face by adhesive from said pattern of adhesive.

5. A business form as set forth in claim 4, including a patch of adhesive applied between said inner face of said face ply relatively outboard one of said transverse lines of weakening and said release face of said release liner.

6. A business form as set forth in claim 2, wherein said adhesive pattern is spaced from said line of weakening to provide an adhesive-free zone outboard and inboard of said line of weakening.

7. A business form as set forth in claim 2, including a masking area printed on one of said inner face or release face intermediate said top face and said indicia printed within said slip area of said back face.

8. A business form as set forth in claim 7, wherein said masking area is reverse printed to provide a printed area within said masking area.

9. A business form as set forth in claim 2, wherein said pattern of adhesive and pattern of release coating are applied to provide first and second discrete and laterally spaced pull tabs where the face ply and release liner are directly adhesively connected without intervention of release coating therebetween.

10. A business form as set forth in claim 9, including two spaced, substantially parallel pull tab perforation lines in said central portion and a label area for receiving address indicia on said top face thereof and located between said pull tabs, said label area being separable from said slip area.

11. A business form as set forth in claim 10, including another perforation line substantially parallel to said pull tab perforation lines for defining a return label between said label area and one of said pull tabs, said pattern of adhesive including adhesive between at least a part of the inner face within said return label and said release liner, and said pattern of release coating including release coating intermediate the adhesive within said return label and said release face.

12. A business form as set forth in claim 1, wherein said form is provided as a continuous web.

13. A business form as set forth in claim 1, wherein said form is provided as an individual two-ply sheet.

14. A business form for adhesive application to a substrate and for carrying publicly displayed indicia on one side and hidden indicia on a second, opposite side, said business form comprising:

a first ply having a top face and an inner face and a surrounding margin;

a second ply having a liner face and a back face and a surrounding perimeter, said second ply being superposed below said first ply;

adhesive applied between at least part of said first ply and said second ply for adhesively interconnecting said first ply and second ply;

release coating located between at least a part of said adhesive and at least a part of said second ply;

a line of separation in said second ply located inboard of said perimeter to define a packing slip within said second ply;

a first line of weakness in said first ply defining a central portion inboard of said surrounding margin, said line of weakness defining said central portion being in substantial registry with said line of separation;

a second line of weakness in said first ply extending from said margin substantially across said first ply and parallel to at least a part of said first line of weakness.

15. A business form for adhesive application to a substrate and for carrying publicly displayed indicia on one side and hidden indicia on a second, opposite side, said business form comprising:

a face ply including a top, face, an inner face, and a face outer edge,

said face ply further including a line of weakness defined therein and located inboard of the face outer edge to present a separable central portion,

said face ply further including a surrounding margin defined between the face outer edge and the line of weakness;

a release liner including a release face oriented toward the inner face of the face ply, a back face, and a release outer edge,

said release liner further including a line of separation defined therein and located inboard of the release outer edge,

said line of separation being spaced inwardly from the face outer edge; and

a layer of adhesive applied in a pattern between said inner face of said face ply and said release face of said release liner, said adhesive pattern including adhesive between the release liner and at least a portion of the surrounding margin.

16. A business form as set forth in claim 15, and a layer of release coating between said inner face of said face ply and said release face of said release liner.

17. A business form as set forth in claim 15, said line of separation being in substantial registry with the line of weakness.

18. A business form as set forth in claim 17, said line of separation being spaced slightly inward from the line of weakness.

19. A business form as set forth in claim 16, said adhesive pattern including adhesive between at least part of said central portion and said release liner.

20. A business form as set forth in claim 19, said release coating being applied in a pattern such that the central portion is securely and substantially permanently bonded to the release liner.

21. A business form as set forth in claim 20, said line of separation defining a packing slip within the release liner, said packing slip being bonded to the central portion.

22. A business form as set forth in claim 15; and indicia printed within said central portion on said inner face.

23. A business form as set forth in claim 22, indicia printed within said central portion of said top face including package addressing information.

24. A business form as set forth in claim 15, said form being provided as a continuous web.