



US00RE39080E

(19) **United States**
(12) **Reissued Patent**
Johnston

(10) **Patent Number: US RE39,080 E**
(45) **Date of Reissued Patent: Apr. 25, 2006**

(54) RATE LOOP PROCESSOR FOR PERCEPTUAL ENCODER/DECODER	4,516,258 A	5/1985	Ching et al.	381/31
	4,535,472 A	8/1985	Tomcik	381/31
	4,646,061 A	2/1987	Bledsoe	340/347
(75) Inventor: James David Johnston , Redmond, WA (US)	4,790,016 A	12/1988	Mazor et al.	381/36
	4,803,727 A	2/1989	Holt et al.	381/1
	4,821,260 A	4/1989	Klank et al.	370/77
(73) Assignee: Lucent Technologies Inc. , Murray Hill, NJ (US)	4,860,313 A	8/1989	Shapiro	375/27
	4,860,360 A	8/1989	Boggs	381/48

(Continued)

(21) Appl. No.: **10/218,232**

(22) Filed: **Aug. 13, 2002**

Related U.S. Patent Documents

Reissue of:

(64) Patent No.: **5,627,938**
Issued: **May 6, 1997**
Appl. No.: **08/310,898**
Filed: **Sep. 22, 1994**

U.S. Applications:

(63) Continuation of application No. 07/844,811, filed on Mar. 2, 1992, now abandoned, which is a continuation-in-part of application No. 07/844,967, filed on Feb. 28, 1992, now abandoned, which is a continuation of application No. 07/292,598, filed on Dec. 30, 1988, now abandoned.

(51) **Int. Cl.**
G10L 19/02 (2006.01)
G10L 21/04 (2006.01)

(52) **U.S. Cl.** **704/200.1**; 704/229

(58) **Field of Classification Search** 704/200.1,
704/203, 205, 206, 207, 209, 219, 222, 229,
704/230

See application file for complete search history.

(56) **References Cited**

U.S. PATENT DOCUMENTS

3,989,897 A	11/1976	Carver	179/1 P
4,216,354 A	8/1980	Esteban et al.	179/15.55 R
4,349,698 A	9/1982	Iwahara	179/1 G
4,356,349 A	10/1982	Robinson	179/1 G

FOREIGN PATENT DOCUMENTS

EP	0 193 143 A2	2/1986
EP	0193143	9/1986
EP	0 376 553 A2	12/1989
EP	0376553	7/1990
EP	0 559 383 A1	2/1993
EP	0559383	9/1993
EP	0 446 037 B1	10/1997
JP	63-7023 A	1/1988
JP	2796673 B2	3/1989
JP	H01(1989)-500695 A	3/1989
JP	2792853 B2	9/1998

OTHER PUBLICATIONS

Zwicker, "Psychoakustic," 1982, pp 31-53.*
K. Brandenburg, "OCF—A New Coding Algorithm For High Quality Sound Signals", IEEE ICASSP, pp. 141-144, 1987.

(Continued)

Primary Examiner—Abul K. Azad

(57) **ABSTRACT**

A method and apparatus for quantizing audio signals is disclosed which advantageously produces a quantized audio signal which can be encoded within an acceptable range. Advantageously, the quantizer uses a scale factor which is interpolated between a threshold based on the calculated threshold of hearing at a given frequency and the absolute threshold of hearing at the same frequency.

3 Claims, 10 Drawing Sheets

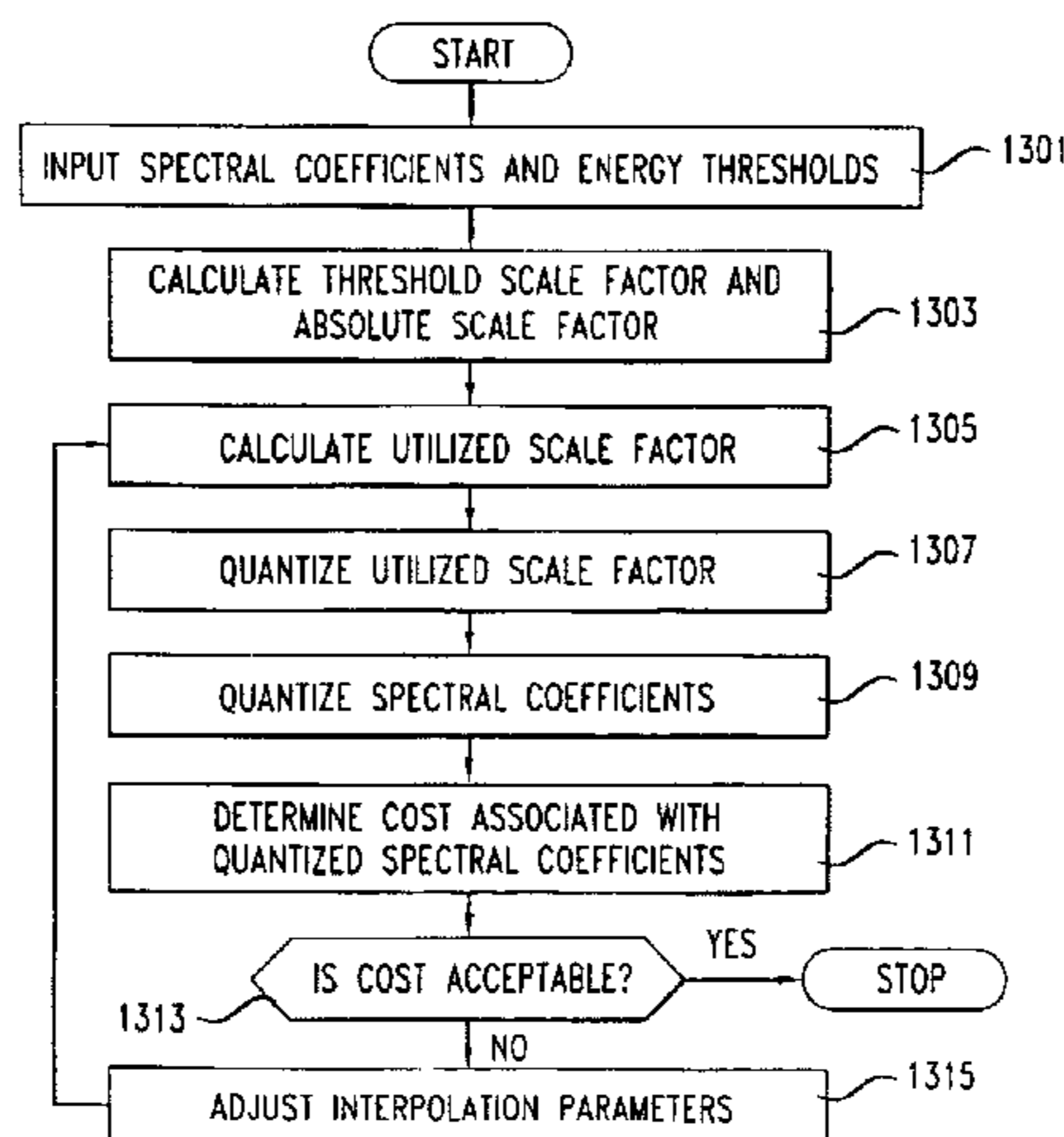

U.S. PATENT DOCUMENTS

4,881,267	A	11/1989	Taguchi	381/40
4,896,362	A	1/1990	Veldhuis et al.	381/30
4,912,763	A	3/1990	Galand et al.	381/31
4,914,701	A	4/1990	Zibman	381/36
4,941,152	A	7/1990	Medan	375/27
4,945,567	A	7/1990	Ozawa	381/49
4,949,383	A	8/1990	Koh et al.	381/31
4,953,214	A	8/1990	Takeguchi et al.	381/31
4,972,484	A	11/1990	Theile et al.	381/37
5,014,318	A	5/1991	Schott et al.	381/47
5,040,217	A	8/1991	Brandenburg et al.	381/47
5,079,547	A	1/1992	Fuchigama et al.	341/51
5,109,417	A	4/1992	Fielder et al.	381/36
5,151,941	A	9/1992	Nishiguchi et al.	381/46
5,185,800	A	2/1993	Mahieux	381/29
5,218,435	A	6/1993	Lim et al.	358/133
5,227,788	A	7/1993	Johnston et al.	341/63
5,230,038	A	7/1993	Fielder et al.	395/2
5,235,671	A	8/1993	Mazor	395/2
5,274,740	A	12/1993	Davis et al.	395/2.29
5,285,498	A	2/1994	Johnston	381/2
5,297,236	A	3/1994	Antill et al.	395/21.12
5,341,457	A	8/1994	Hall, II et al.	395/2.35
5,357,594	A	10/1994	Fielder	395/2.2
5,394,473	A	2/1995	Davidson	381/36
5,400,433	A	3/1995	Davis et al.	395/2.29
5,479,562	A	12/1995	Fielder et al.	395/2.38
5,535,300	A	7/1996	Hall, II et al.	395/2.36
5,583,962	A	12/1996	Davis et al.	395/2.38
5,592,584	A	1/1997	Ferreira et al.	395/2.12
5,627,938	A	5/1997	Johnston	395/2.39
5,633,981	A	5/1997	Davis	395/2.39
5,752,225	A	5/1998	Fielder	704/229
5,924,060	A	7/1999	Brandenburg	704/200
RE36,714	E	5/2000	Brandenburg et al.	704/227

OTHER PUBLICATIONS

J. Princen et al., "Subband Transform Coding Using Filter Bank Designs Based on Time Domain Aliasing Cancellation", IEEE ICASSP, pp. 2161-2164, 1987.

J. Princen, et al., "Analysis/Synthesis Filter Bank Design Based on Time Domain Aliasing Cancellation", IEEE ICASSP, vol. AASP-34, No. 5, pp. 1153-1161, 1986.

D.E. Knuth, et al., "The Art of Computer Programming", 2nd Ed., vol. 2, Reading, Mass, pp. 274-275, 1981.

Jetzt, "Critical Distance Measurements on Rooms From the Sound Energy Spectrum Response", Journal of the Acoustical Society of America, vol. 65, pp. 1204-1211, 1979.

B. Scharf, Foundations of Modern Auditory Theory, edited by Jerry V. Tobias, Chapter 5, Academic Press, N.Y., N.Y., pp. 157-202, 1970.

R. P. Hellman, "Asymmetry of Masking Between Noise and Tone", Perception and Psychophysics II, pp. 241-246, 1972.

A. Fletcher, "Auditory Patterns", Reviews of Modern Physics, vol. 12, pp. 47-65, 1940.

E. F. Schroeder, et al., "MSC: Stereo Audio Coding With CD-Quality and 256 kBIT/SEC", IEEE Transactions on Consumer Electronics, vol., CE-33, No. 4, pp. 512-519, Nov. 1987.

J.D. Johnston, "Transform Coding of Audio Signals Using Perceptual Noise Criteria", IEEE Journal On Selected Areas In Communications, vol. 6, No. 2, pp. 314-323, Feb. 1988.

N.S. Jayant, et al., "Digital Coding of Waveforms—Principals and Applications to Speech and Video", Chapter 12, Transform Coding, 1987.

E. Tan, et al., "Digital Audio Tape for Data Storage", IEEE Spectrum, pp. 34-38, Oct. 1989.

M.R. Schroeder, et al., "Optimizing Digital Speech Coders by Exploiting Masking Properties of the Human Ear", Journal of Acoustical Society of America, vol. 66 (6), pp. 1647-1652, Dec. 1979.

"FX/FORTRAN Programmer's Handbook", Alliant Computer Systems Corp., Jul. 1988.

R.N.J. Veldhuis, et al., "Subband Coding of Digital Audio Signals", Phillips Journal of Research, vol. 44, Nos. 2, 3, pp. 329-343, Jul. 1989.

H.G. Musmann, "The ISO Audio Coding Standard", Globecom '90, vol. 1(3), Dec. 1990, N.Y., pp. 511-517.

"Aspec: Adaptive Spectral Entropy Coding of High Quality Music Signals", AES 90th Convention, 1991.

K. Brandenburg, "Second Generation Perpetual Audio Coding: The Hybrid Coder", AES 89th Convention, 1990.

J.D. Johnston, "Perceptual Transform Coding of Wideband Stereo Signals", IEEE ICASSP, pp. 1993-1996, 1989.

J.D. Johnston, "Estimation of Perceptual Entropy Using Noise Masking Criteria", IEEE UCASSP, pp. 2524-2527, 1989.

K. Brandenburg, "Evaluation Of Quality For Audio Encoding At Low Bit Rates", AES 82nd Convention, pp. 1-11, Mar., 1987.

E. Zwicker, et al., Absolute and Masked Thresholds of Continuous Sounds, pp. 65-81 of "The Ear As A Communication Receiver" (Original German edition "Das Ohr als Nachrichtenempfänger", Second Rev. ed. 1967).

G. Theile, et al., "Low Bit-Rate Coding of High-Quality Audio Signals" AES 82nd Convention, pp. 1-31, Mar., 1987.

G. Theile, et al., "Low Bit-Rate Coding of High-Quality Audio Signals An Introduction to the MASCAM System" AES 7th International Conf., EBU Review—Technical, No. 230, pp. 158-209, Aug., 1988.

R. G. van der Waal, et al., "Subband Coding of Stereophonic Digital Audio Signals", IEEE, pp. 3601-3604, Jul., 1991.

K. Brandenburg, "Aspec Coding", AES 10th International Conf., pp. 81-90, Sep. 1991.

Brandenburg et al., "A Digital Signal Processor for Real Time Adaptive Transform Coding of Audio Signals Up To 20 kHz Bandwidth," IEEE Int'l Conf on Circuits and Computers, 1982, pp. 474-477.

Krahé, "Neues Quellencodierungsverfahren für qualitativ hochwertige, digital Audiosignale," University Duisburg, Nov. 1985.

Press et al., "Numerical Recipes," Cambridge University Press, 1986, pp. 77-92, 240-247 and 595.

Tribolet et al., "Frequency Domain Coding of Speech," IEEE Trans. on Acoust., Speech and Sig. Proc., Oct. 1979, pp. 512-530.

AT&T Bell Laboratories et al., "ASPEC," ISO-MPEG Audio Coding Submission, submitted Oct. 18, 1989, amended Dec. 11, 1989, revised Jun. 18, 1990.

Johnston, "Transform Coding of Audio Signals Using Perceptual Noise Criteria," IEEE J. Selected Areas in Comm., vol. 6, No. 2, Feb. 1988, pp. 314-323.

Brandenburg, K.-H., Langenbacher, G.C., Shram, H., Seitzer, D.; *A Digital Signal Processor For Real Time Adaptive Transform Coding Of Audio Signals Up To 20 KHZ Bandwidth*, IEEE Int'l Conf. On Circuits and Computers, 1982, pp. 474-477.

- Crochiere, R.E., Tribolet, J.M.; *Frequency Domain Techniques For Speech Coding*, J. Acoust. Soc. Of Amer., Dec. 1979, pp. 1642–1646.
- Crochiere, R.E.; *Sub-Band Coding*, The Bell System Technical Journal, vol. 60, No. 7, Sep. 1981, pp. 1633–1653.
- Flanagan, J.L., Schroeder, M.R., Atal, B.S., Crochiere, R.E., Jayant, N.S., Tribolet, J.M.; *Speech Coding*, IEEE Transactions on Communications, vol. COM-27, No. 4, Apr. 1979, pp. 710–736.
- Grauel, C.; *Sub-Band Coding With Adaptive Bit Allocation*, Signal Processing 2, North-Holland Publishing Co., 1980, pp. 23–30.
- Heron, C.D., Crochiere, R.E., Cox, R.V.; *A 32-Band Sub-band/Transform Coder Incorporating Vector Quantization For Dynamic Bit Allocation*, Proceedings IEEE ICASSP, 1983, pp. 1276–1279.
- Jayant, N.S., Noll, P.; *Digital Coding of Waveforms*, Prentice-Hall, 1984, pp. 56–58.
- Krahe, D.; *New Source Coding Method For High Quality Digital Audio Signals*, University Duisburg Nov., 1985 (Original and English Translation).
- Press, W.H., Flannery, B.P., Teukolsky, S.A., Vetterling, W.T.; *Numerical Recipes* Cambridge University Press, 1986, pp. 77–92, 240–247 and 595.
- Ramstad, T.A.; *Sub-band Coder With A Simple Adaptive Bit-Allocation Algorithm: A Possible Candidate for Digital Mobile Telephony?* Proceedings IEEE ICASSP, 1982, vol. 1, pp. 203–207.
- Tribolet, J.M., Crochiere, R. E., *Frequency Domain Coding of Speech*, IEEE Transactions on Acoustics, Speech, and Signal Processing, vol. ASSP-27, No. 5, Oct. 1979, pp. 512–530.
- Zelinski, R., Noll, P.; *Adaptive Transform Coding of Speech Signals*, IEEE Transactions on Acoustics, Speech, and Signal Processing, vol. ASSP-25, No. 4, Aug. 1977, pp. 299–309.
- Zwicker, E., Terhardt, E.; *Facts And Models In Hearing*, Springer-Verlag 1974, pp. 251–257.
- Dolby's Preliminary Invalidity Contentions, Dolby Laboratories Inc. and Dolby Laboratories Licensing Corporation v. Lucent Technologies Inc. and Lucent Technologies Guardian I LLC*, United States District Court, Northern District of California, San Jose Division, Apr. 3, 2003.
- Brandenburg, K., et al., "Transmission of High Quality Audio Signals with Bit Rates in the Range of 64–144 KBIT/SEC," ITG-Conference Proceedings, Information Technology Society, pp. 217–222, VDE-Verlag GmbH, Berlin, Nov., 1988.
- Brandenburg, K., "A Contribution on the Methods of and Evaluation of the Quality of High-quality Music Coding," The Department of Engineering at the University of Erlangen-Nuremberg, Doctor of Engineering Thesis, pp. 1–199, Erlangen University Library, Erlangen, Germany, Jan., 1989.
- Brandenburg, K., "High quality sound coding at 2.5 bit/sample," 84th Convention, AES (Audio Engineering Society) Mar. 1–4, 1988, Paris, Preprint 2582 (D-2), 8 pages, Audio Engineering Society, New York, 1988.
- Brandenburg, K., et al., "Low Bit Rate Coding of High-Quality Digital Audio: Algorithms and Evaluation of Quality," AES Conference, May 14–17, 1989, Toronto, Canada, pp. 1–25, Audio Engineering Society, New York.
- Ernst Eberlein, et al., Psychoacoustically Based Measuring Device For Optimizing Data Reduction Methods, Tonmelstertagung '88, pp. 552–564, Nov. 19, 1988.
- Brandenburg, K., et al., "OCF: Coding High Quality Audio with Data Rates of 64kbit/sec," AES Convention, Nov. 3–6, 1988, Los Angeles, California, 12 pages, Audio Engineering Society, New York.
- Seitzer, et al., "Digital Coding of High Quality Audio," Proceedings Advanced Computer Technology, Reliable Systems and Applications, 5th Annual European Computer Conference, Bologna, May 13–16, 1991, pp. 148–154, IEEE Computer Society Press, Los Alamitos, California, 1991.
- Dolby's Supplemental Invalidity Contentions, Dolby Laboratories Inc. and Dolby Laboratories Licensing Corporation vs. Lucent Technologies Inc. and Lucent Technologies Guardian I LLC*, United States District Court, Northern District of California, San Jose Division, Jan. 7, 2004.
- Krasner, M.A., *Digital Encoding of Speech and Audio Signals Based on the Perceptual Requirements of the Auditory System*, MIT Lincoln Laboratory, Technical Report 535, Jun. 18, 1979.
- Krasner, M.A. *Digital Encoding of Speech and Audio Signals Based on the Perceptual Requirements of the Auditory System*, Submitted in Partial Fulfillment of the Requirements for the Degree of Doctor of Philosophy, Massachusetts Institute of Technology, May 4, 1979.
- Terhardt, E., Stoll, G., Seewann, M., Algorithm For Extraction Of Pitch And Pitch Saliency From Complex Tonal Signals, J. Acoust. Soc. Am., 71(3), Mar. 1982, pp. 679–688.

* cited by examiner

FIG. 1
(PRIOR ART)

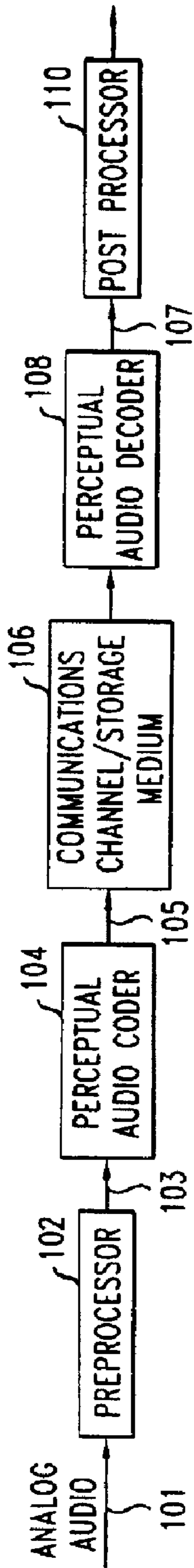

FIG. 2
(PRIOR ART)

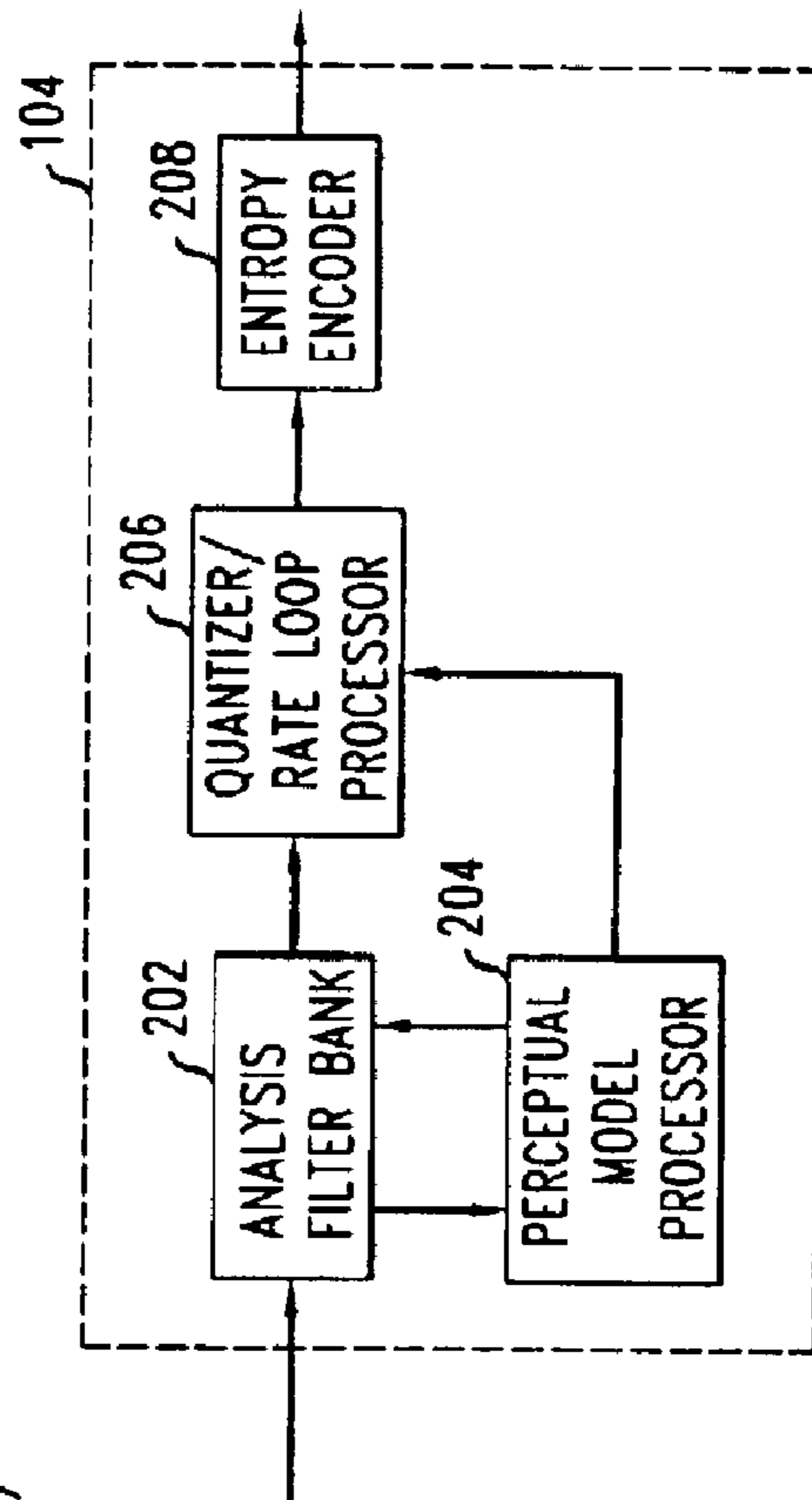

FIG. 3

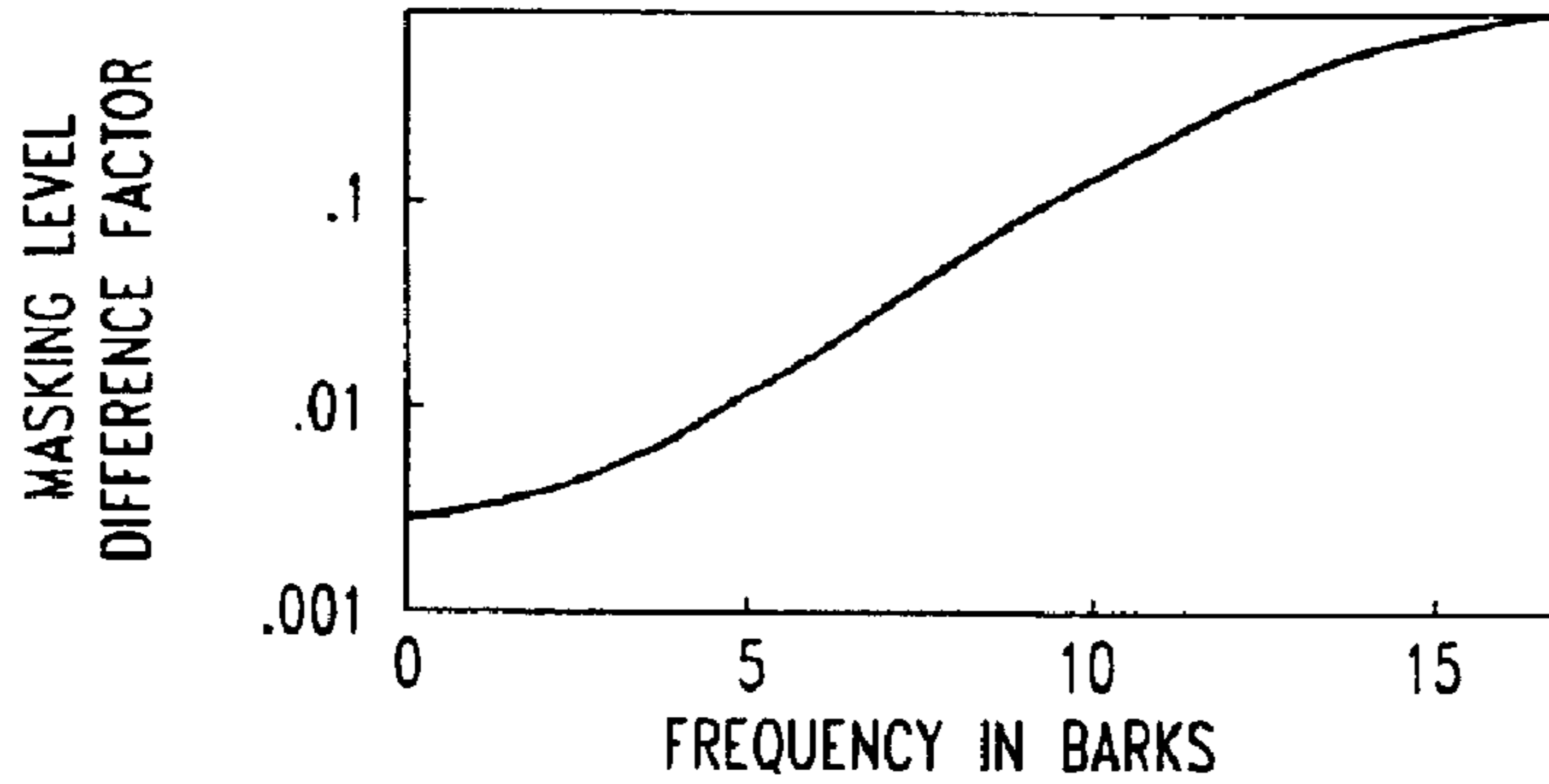

FIG. 8

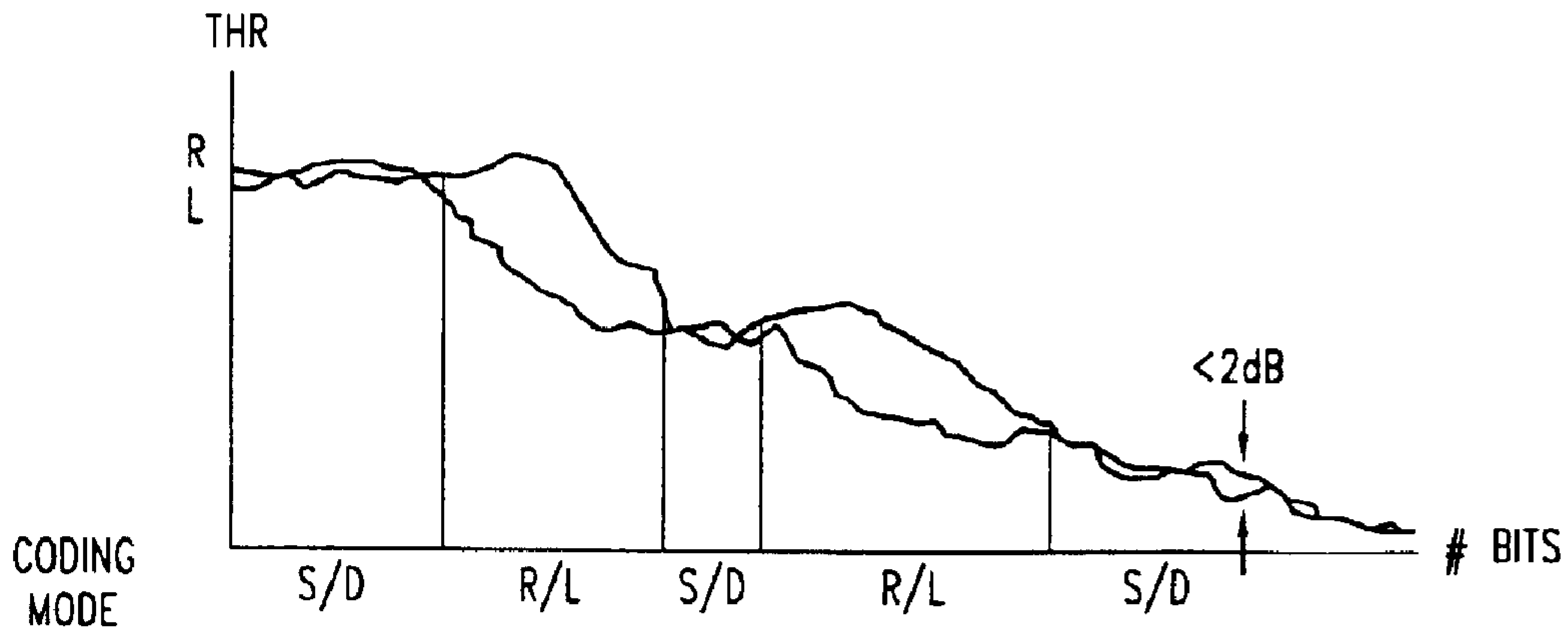

FIG. 10

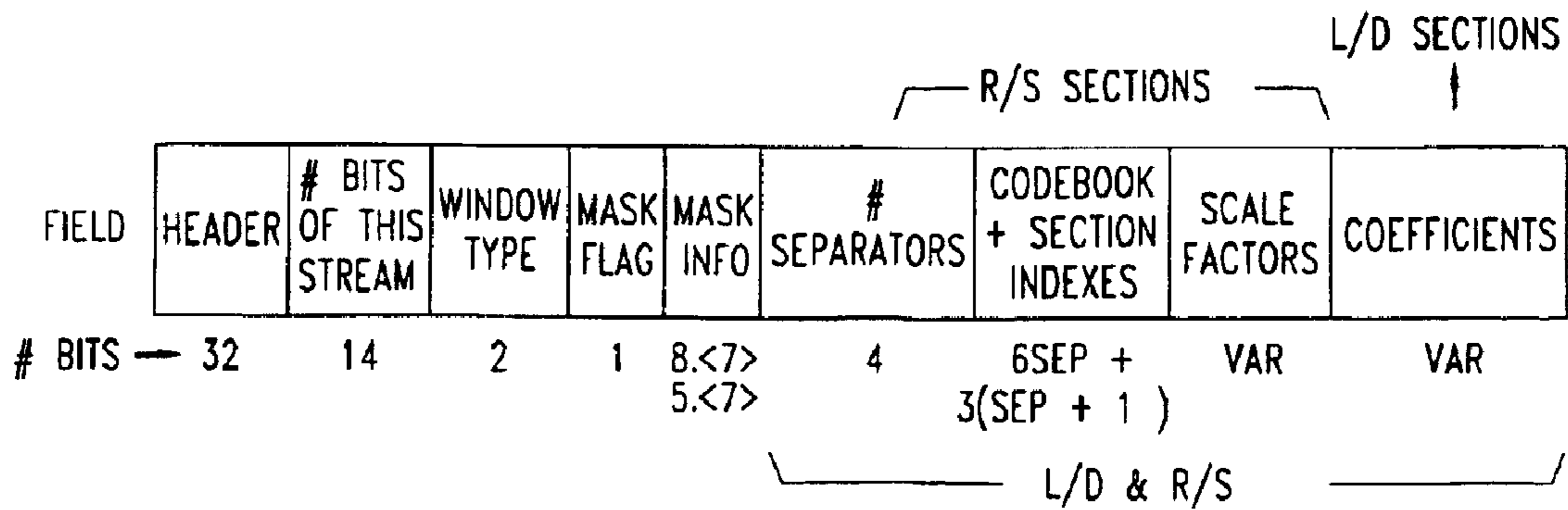
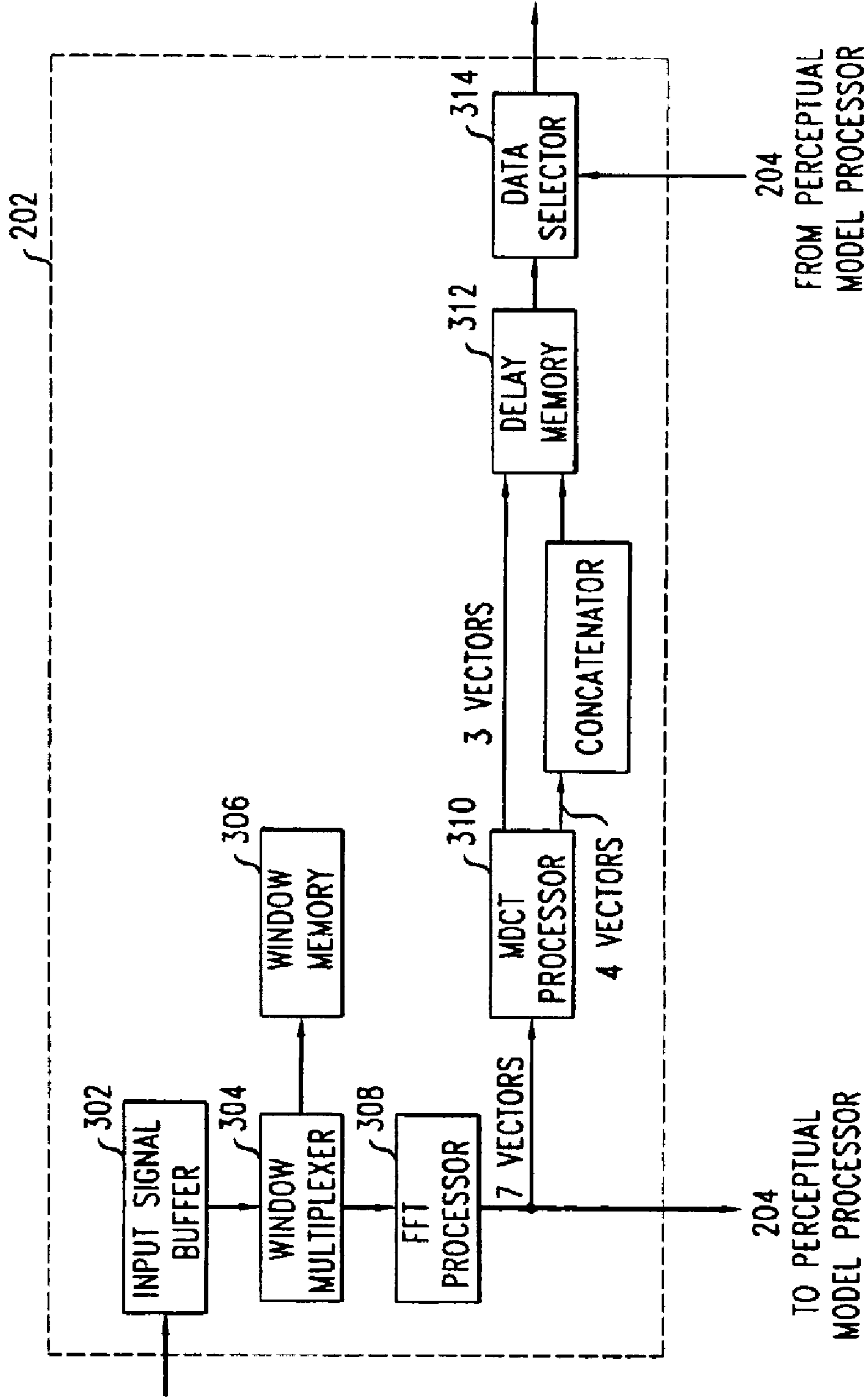

FIG. 4



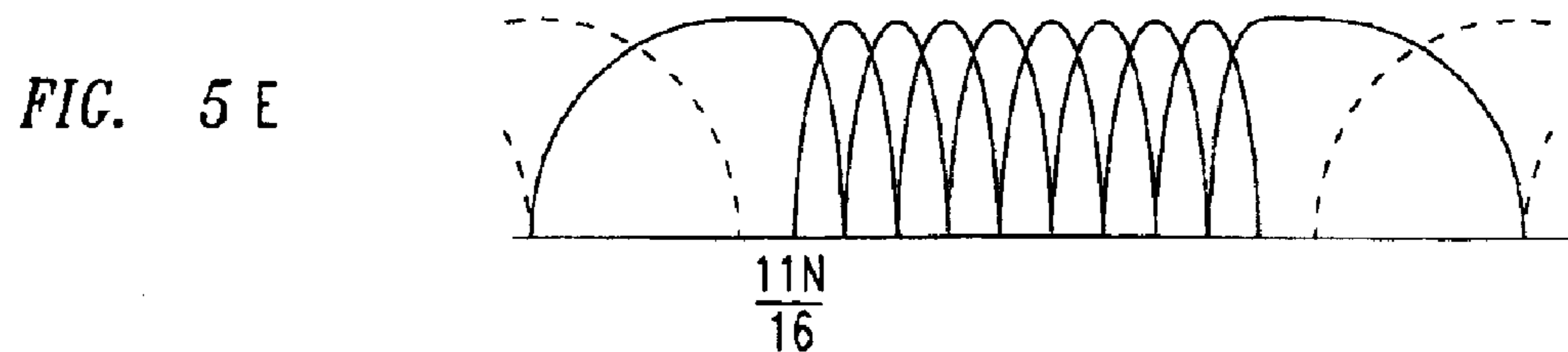
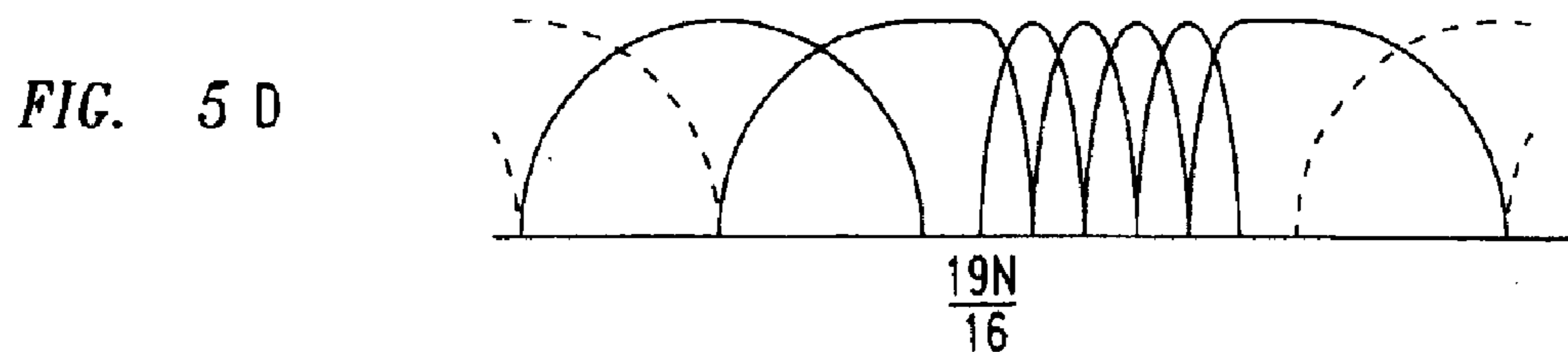
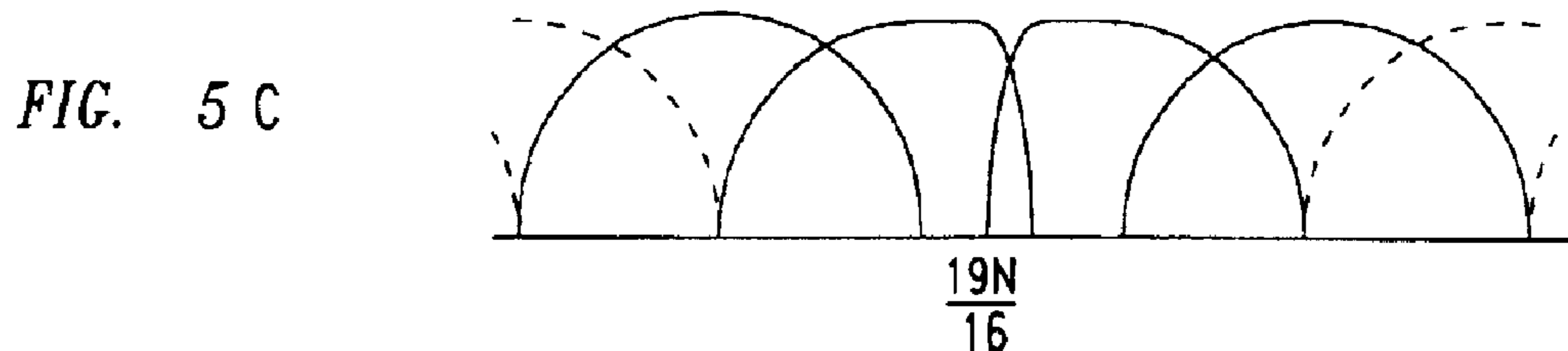
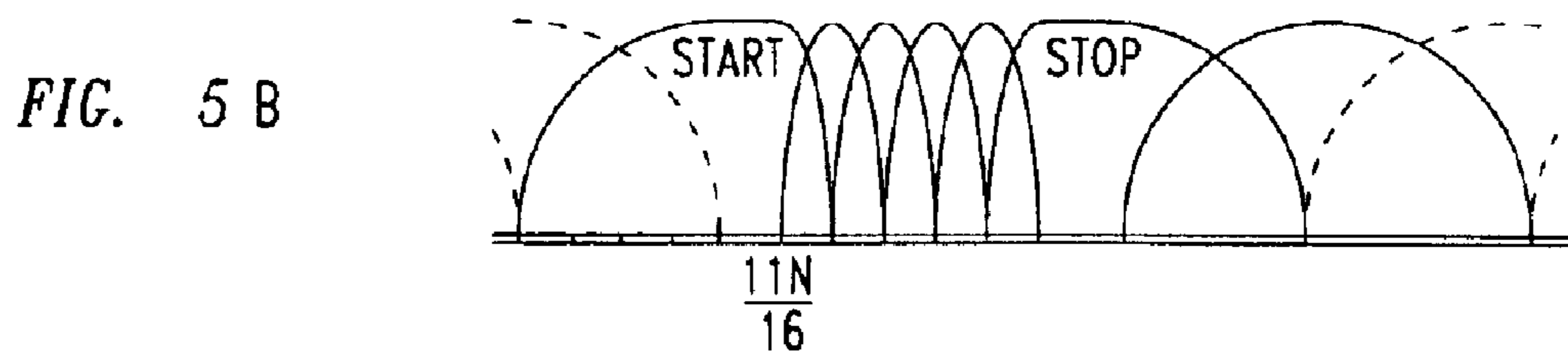
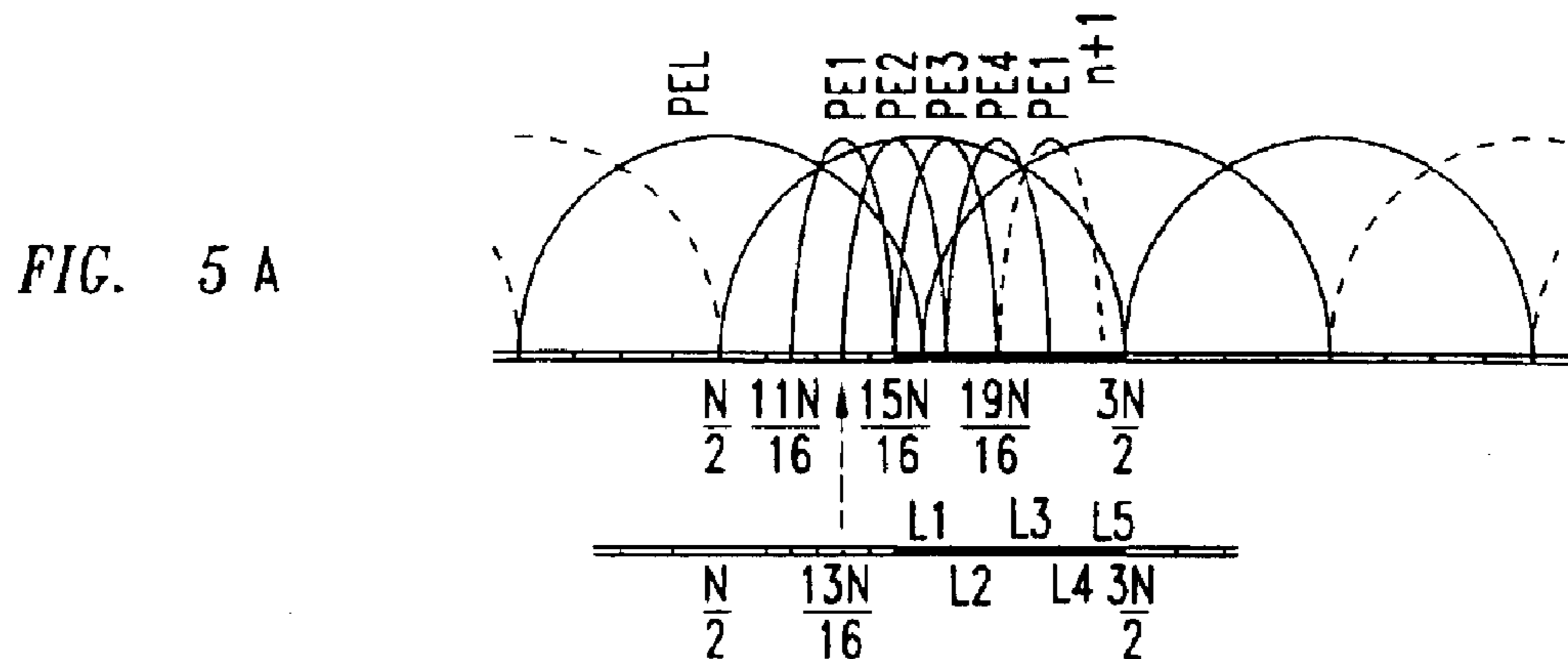

FIG. 6

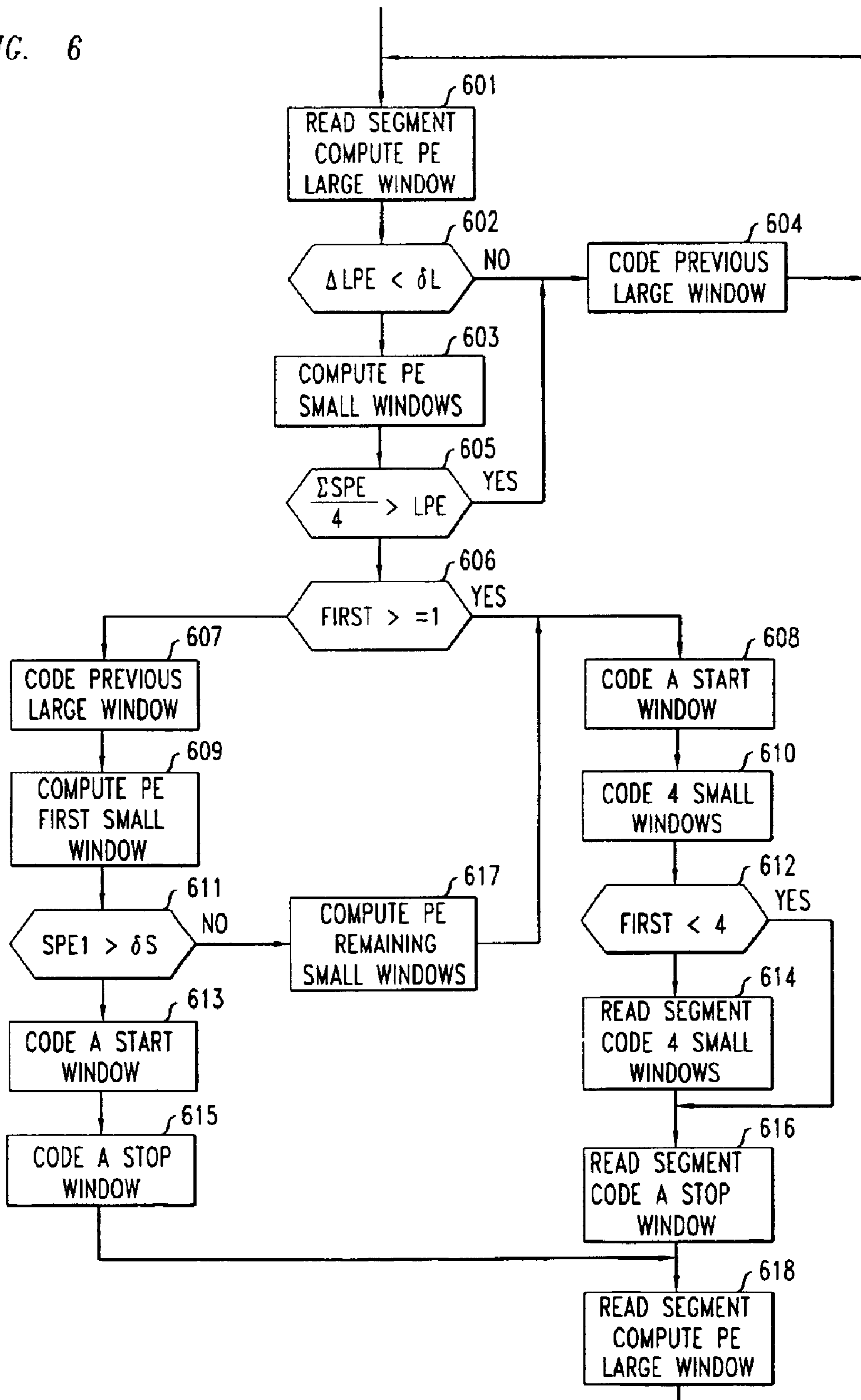

FIG. 7

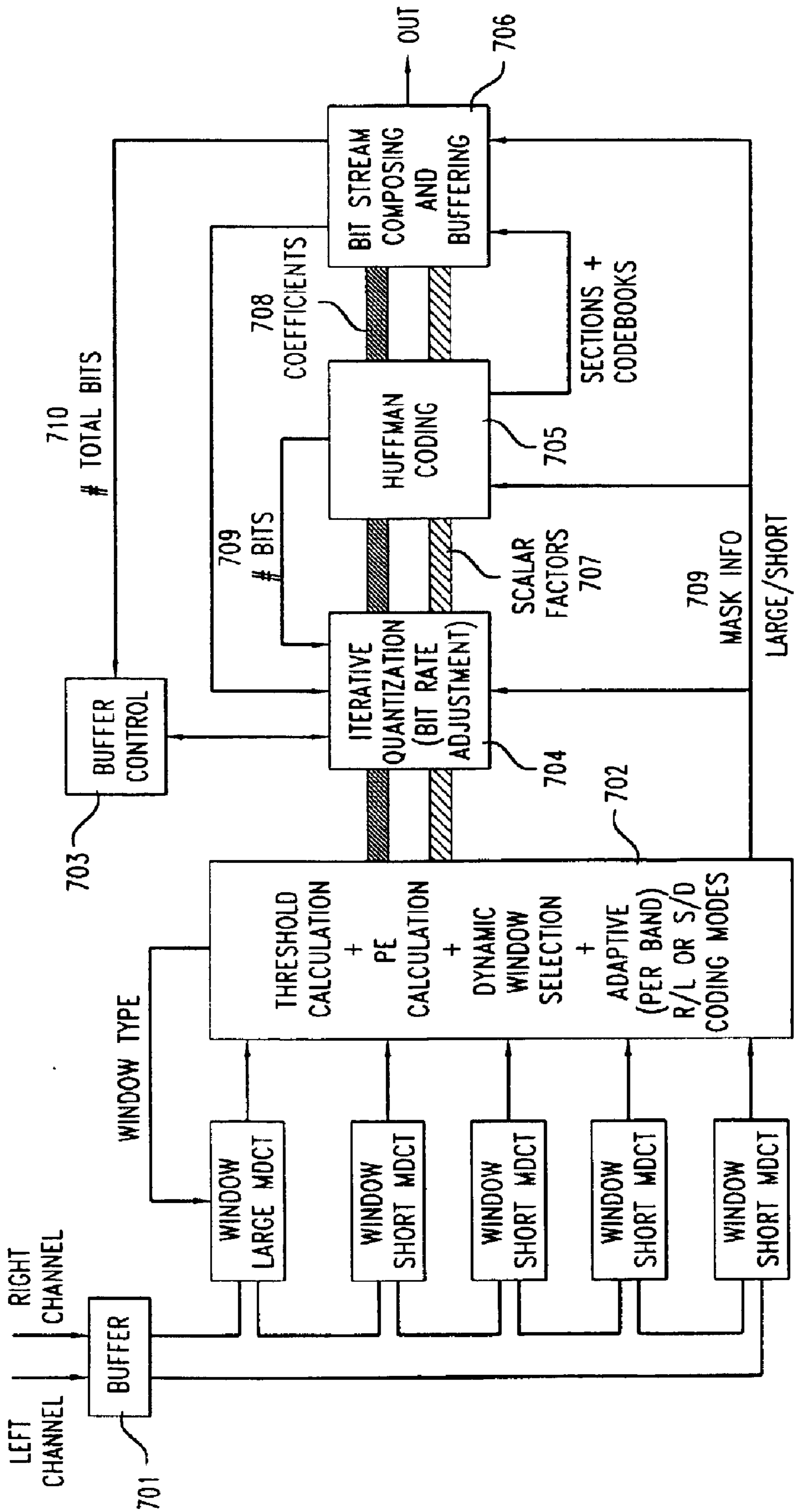

FIG. 9

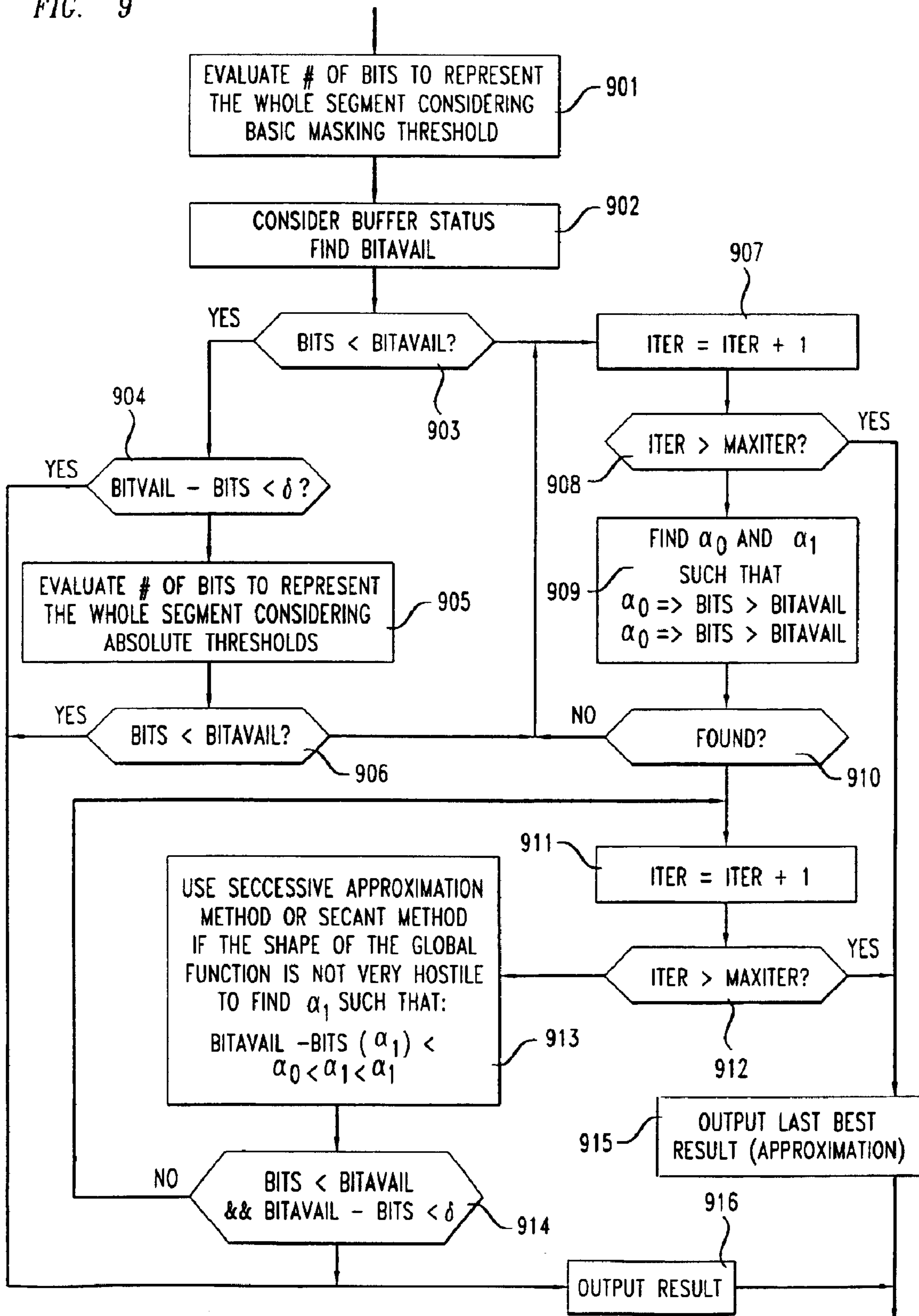
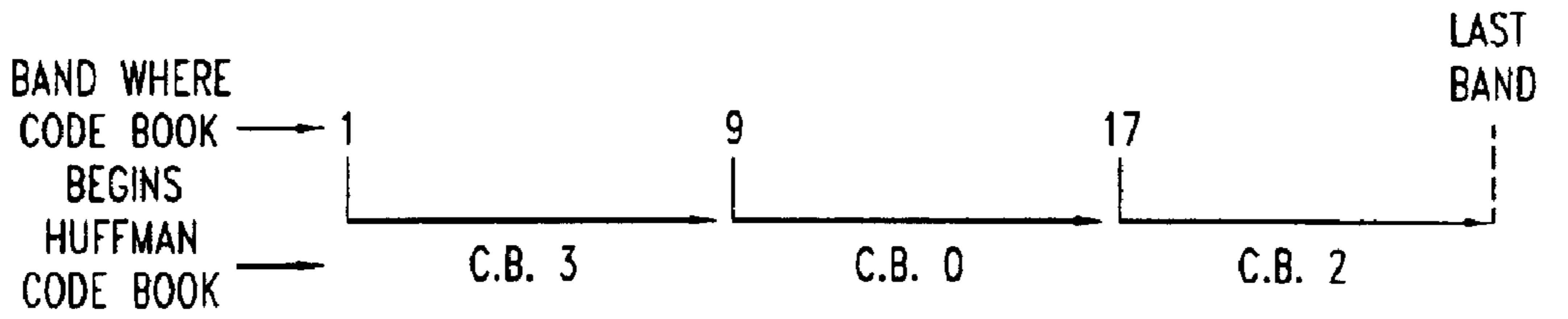

FIG. 11 A



SEPARATORS R/S = K = 2

SECTION INDEX	CODE BOOK	BAND WHERE SECTION BEGINS
1	2	17
2	0	9
3	3	1

FIELD CB=INDX
IN THE STREAM
[2, 17, 0, 9, 3]

FIG. 11 B

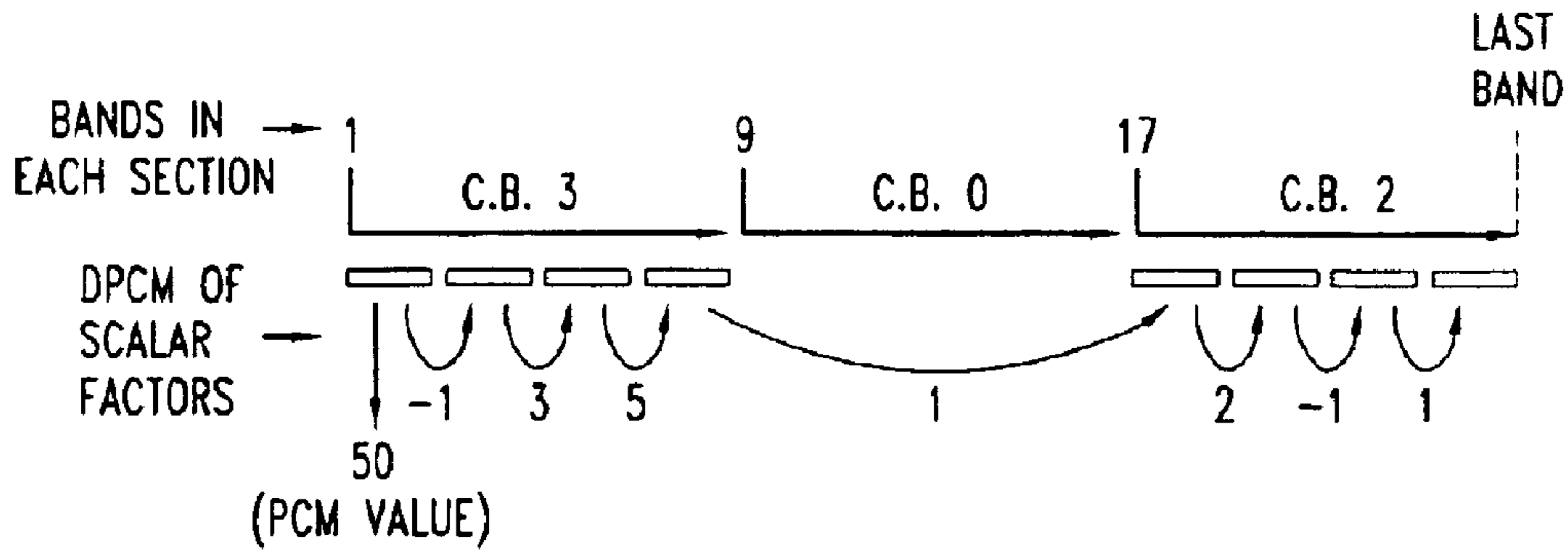

FIELD SCALE FACTORS IN THE STREAM: [1, -1, 2, 1, 5, 3, -1, 50]

FIG. 11 C

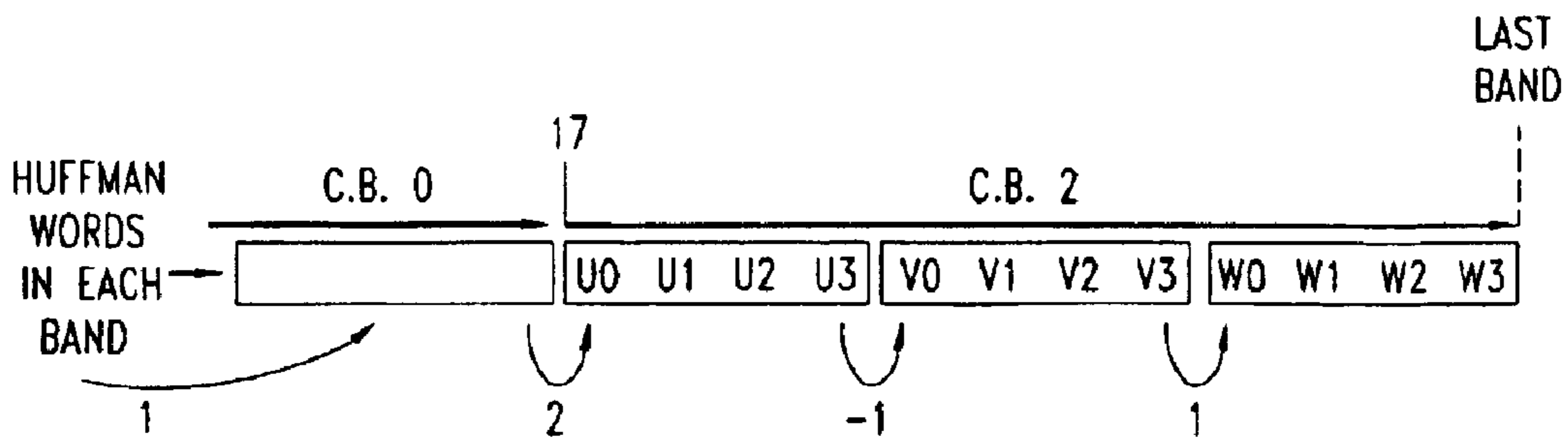

FIELD COEFFICIENTS IN THE STREAM: [W0-3, V0-3, U0-3, ...]

FIG. 12

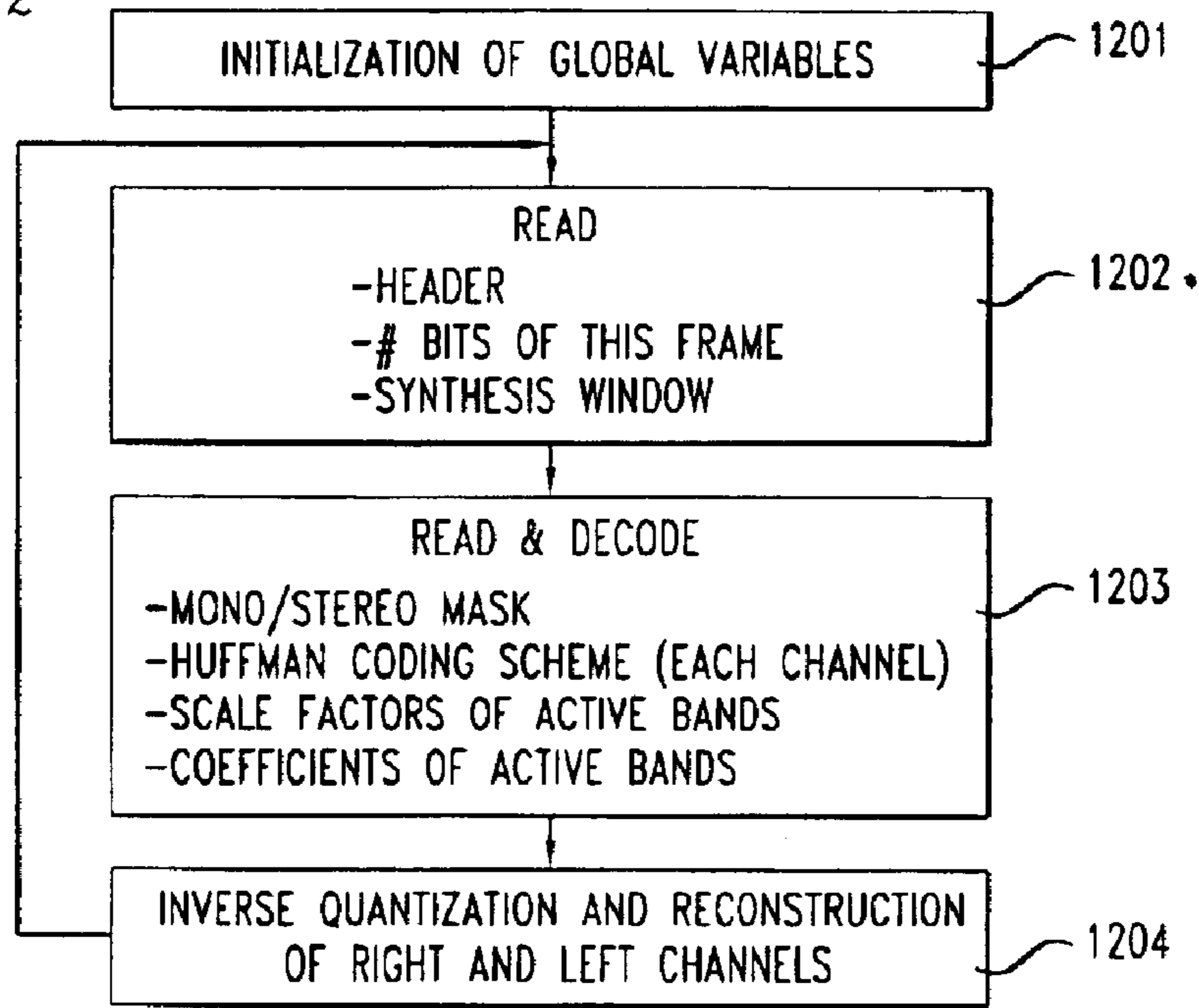

FIG. 13

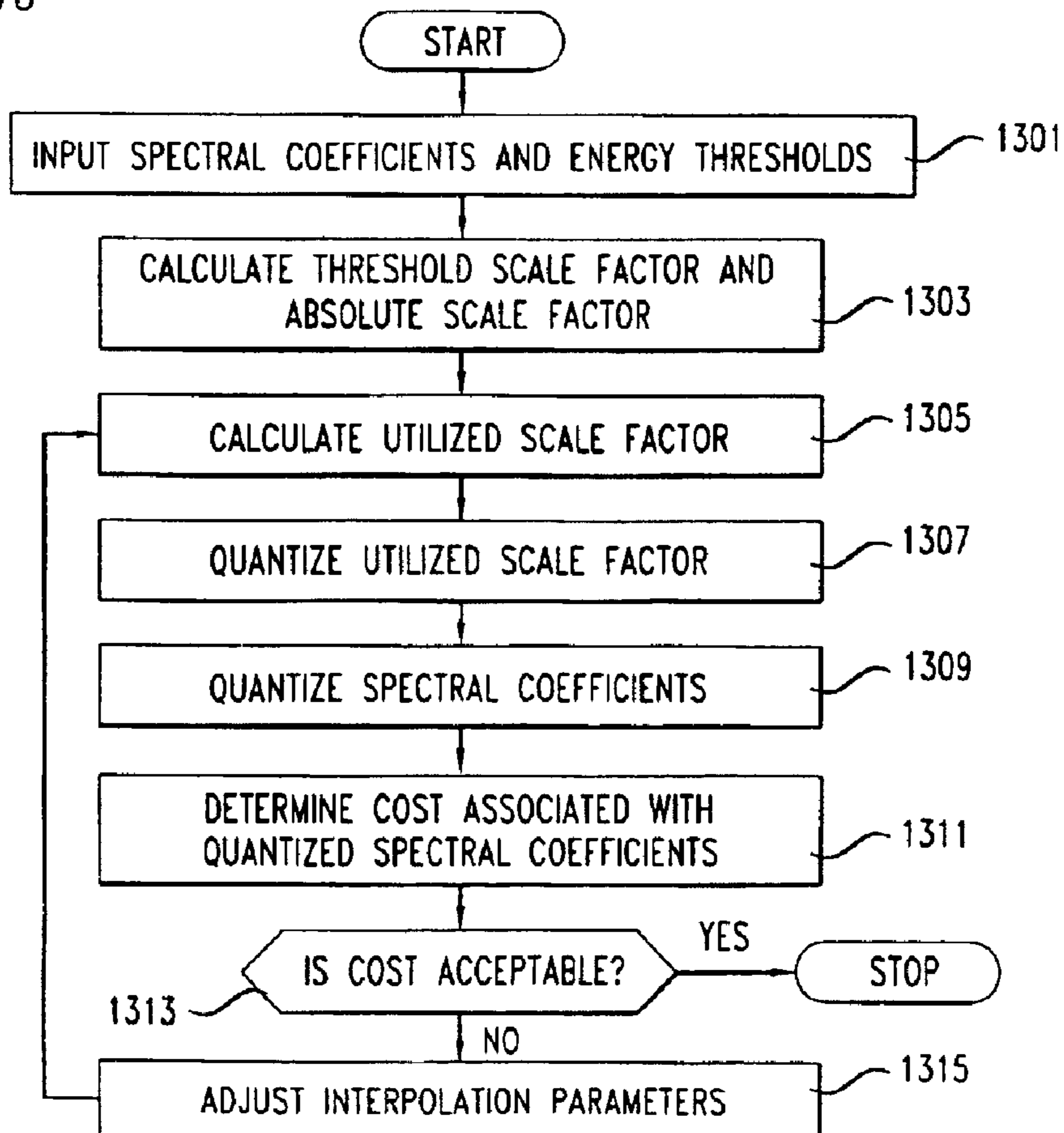
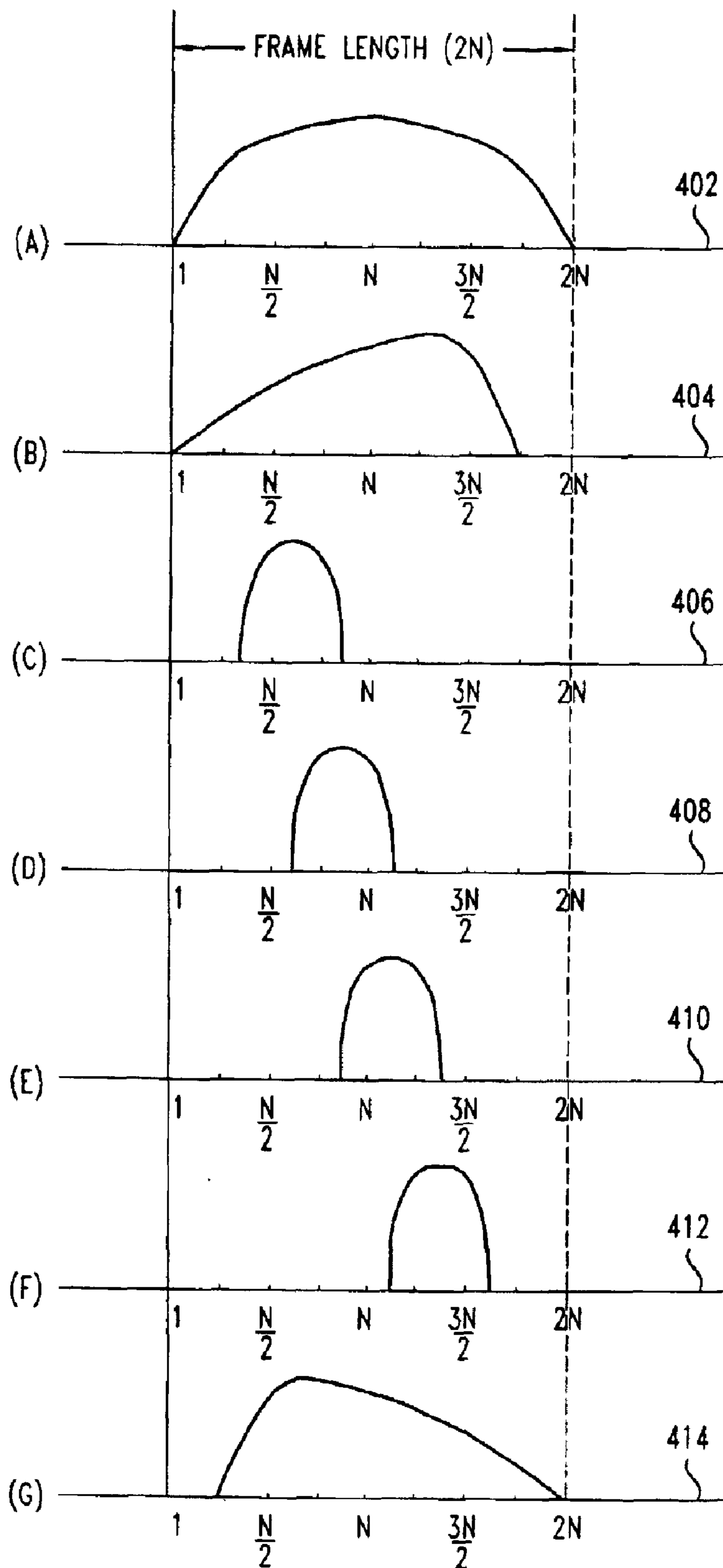

FIG. 14



RATE LOOP PROCESSOR FOR PERCEPTUAL ENCODER/DECODER

Matter enclosed in heavy brackets [] appears in the original patent but forms no part of this reissue specification; matter printed in italics indicates the additions made by reissue.

This is a reissue application of U.S. Pat. No. 5,627,938 filed Sep. 22, 1994 as application Ser. No. 08/310,898 which is a continuation of application Ser. No. 07/844,811, filed on Mar. 2, 1992, now abandoned, which is a continuation-in-part of application Ser. No. 07/844,967 filed Feb. 28, 1992, now abandoned, which is a continuation of Ser. No. 07/292,598 filed Dec. 30, 1988 now abandoned.

CROSS-REFERENCE TO RELATED APPLICATIONS AND MATERIALS

The following U.S. patent applications filed concurrently with the present application and assigned to the assignee of the present application are related to the present application and each is hereby incorporated herein as if set forth in its entirety: "A METHOD AND APPARATUS FOR THE PERCEPTUAL CODING OF AUDIO SIGNALS," by A. Ferreira and J. D. Johnston, application Ser. No. 07/844,819, now abandoned, which in turn was parent of application Ser. No. 08/334,889, allowed Jul. 11, 1996; "A METHOD AND APPARATUS FOR CODING AUDIO SIGNALS BASED ON PERCEPTUAL MODEL," by J.D. Johnston, application Ser. No. 07/844,804, now U.S. Pat. No. 5,285,498, issued Feb. 8, 1994; and "AN ENTROPY CODER," by J.D. Johnston and J.A. Reeds, application Ser. No. 07/844,809, now U.S. Pat. No. 5,227,788, issued Jul. 13, 1993.

FIELD OF THE INVENTION

The present invention relates to processing of signals, and more particularly, to the efficient encoding and decoding of monophonic and stereophonic audio signals, including signals representative of voice and music for storage or transmission.

BACKGROUND OF THE INVENTION

Consumer, industrial, studio and laboratory products for storing, processing and communicating high quality audio signals are in great demand. For example, so-called compact disc ("CD") and digital audio tape ("DAT") recordings for music have largely replaced the long-popular phonograph record and cassette tape. Likewise, recently available digital audio tape ("DAT") recording promise to provide greater flexibility and high storage density for high quality audio signals. See, also, Tan and Vermeulen, "Digital audio tape for data storage", IEEE Spectrum, pp. 34-38 (October 1989). A demand is also arising for broadcast applications of digital technology that offer CD-like quality.

While these emerging digital techniques are capable of producing high quality signals, such performance is often achieved only at the expense of considerable data storage capacity or transmission bandwidth. Accordingly, much work has been done in an attempt to compress high quality audio signals for storage and transmission.

Most of the prior work directed to compressing signals for transmission and storage has sought to reduce the redundancies that the source of the signals places on the signal. Thus, such techniques as ADPCM, sub-band coding and transform coding described, e.g., in N. S. Jayant and P. Noll, "Digital Codin of Waveforms," Prentice-Hall, Inc. 1984,

have sought to eliminate redundancies that otherwise would exist in the source signals.

In other approaches, the irrelevant information in source signals is sought to be eliminated using techniques based on models of the human perceptual system. Such techniques are described, e.g., in E. F. Schroeder and J. J. Platte "MSC"; Stereo Audio Coding with CD-Quality and 256 kBIT/SEC, "IEEE Trans. on Consumer Electronics, Vol. CE-33, No. 4, November 1987; and Johnston, Transform Coding of Audio Signals Using Noise Criteria, Vol. 6, No. 2, IEEE J.S.C.A. (February 1988).

Perceptual coding, as described, e.g., in the Johnston paper related to a technique for lowering required bitrates (or reapportioning available bits) or total number of bits in representing audio signals. In this form of coding, a masking threshold for unwanted signals is identified as a function of frequency of the desired signal. Then, inter alia, the coarseness of quantizing used to represent a signal component of the desired signal is selected such that the quantizing noise introduced by the coding does not rise above the noise threshold, though it may be quite near this threshold. The introduced noise is therefore masked in the perception process. While traditional signal-to-noise ratios for such perceptually coded signals may be relatively low, the quality of these signals upon decoding, as perceived by a human listener, is nevertheless high.

Brandenburg et al, U.S. Pat. No. 5,040,217, issued Aug. 13, 1991, describes a system for efficiently coding and decoding high quality audio signals using such perceptual consideration. In particular, using a measure of the "noise-like" or "tone-like" quality of the input signals, the embodiments described in the latter system provides a very efficient coding for monophonic audio signals.

It is, of course, important that the coding techniques used to compress audio signals do not themselves introduce offensive components or artifacts. This is especially important when coding stereophonic audio information where coded information corresponding to one stereo channel, when decoded for reproduction, can interfere or interact with coding information corresponding to the other stereo channel. Implementation choices for coding two stereo channels include so-called "dual-mono" coders using two independent coders operating at fixed bit rates. By contrast, "joint mono" coders use two monophonic coders but share one combined bit rate, i.e., the bit rate for the two coders is constrained to be less than or equal to a fixed rate, but trade-offs can be made between the bit rates for individual coders. "Joint stereo" coders are those that attempt to use interchannel properties for the stereo pair for realizing additional coding gain.

It has been found that the independent coding of the two channels of a stereo pair, especially at low bit-rates, can lead to a number of undesirable psychoacoustic artifacts. Among them are those related to the localization of coding noise that does not match the localization of the dynamically imaged signal. Thus the human stereophonic perception process appears to add constraints to the encoding process if such mismatched localization is to be avoided. This finding is consistent with reports on binaural masking-level differences that appear to exist, at least for low frequencies, such that noise may be isolated spatially. Such binaural masking-level differences are considered to unmask a noise component that would be masked in a monophonic system. See, for example, B.C.J. Morre, "An Introduction to the Psychology of Hearing, Second Edition," especially chapter 5, Academic Press, Orlando, Fla., 1982.

One technique for reducing psychoacoustic artifacts in the stereophonic context employs the ISO-WG11-MPEG-Audio Psychoacoustic II [ISO] Model. In this model, a second limit of signal-to-noise ratio ("SNR") is applied to signal-to-noise ratios inside the psychoacoustic model. However, such additional SNR constraints typically require the expenditure of additional channel capacity or (in storage applications) the use of additional storage capacity, at low frequencies, while also degrading the monophonic performance of the coding.

SUMMARY OF THE INVENTION

Limitations of the prior art are overcome and a technical advance is made in a method and apparatus for coding a stereo pair of high quality audio channels in accordance with aspects of the present invention. Interchannel redundancy and irrelevancy are exploited to achieve lower bit-rates while maintaining high quality reproduction after decoding. While particularly appropriate to stereophonic coding and decoding, the advantages of the present invention may also be realized in conventional dual monophonic stereo coders.

An illustrative embodiment of the present invention employs a filter bank architecture using a Modified Discrete Cosine Transform (MDCT). In order to code the full range of signals that may be presented to the system, the illustrative embodiment advantageously uses both L/R (Left and Right) and M/S (Sum/Difference) coding, switched in both frequency and time in a signal dependent fashion. A new stereophonic noise masking model advantageously detects and avoids binaural artifacts in the coded stereophonic signal. Interchannel redundancy is exploited to provide enhanced compression for without degrading audio quality.

The time behavior of both Right and Left audio channels is advantageously accurately monitored and the results used to control the temporal resolution of the coding process. Thus, in one aspect, an illustrative embodiment of the present invention, provides processing of input signals to terms of either a normal MDCT window, or, when signal conditions indicate, shorter windows. Further, dynamic switching between RIGHT/LEFT or SUM/DIFFERENCE coding modes is provided both in time and frequency to control unwanted binaural noise localization, to prevent the need for overcoding of SUM/DIFFERENCE signals, and to maximize the global coding gain.

A typical bitstream definition and rate control loop are described which provide useful flexibility in forming the coder output. Interchannel irrelevancies, are advantageously eliminated and stereophonic noise masking improved, thereby to achieved improved reproduced audio quality in jointly coded stereophonic pairs. The rate control method used in an illustrative embodiment uses an interpolation between absolute threshold and masking threshold for signals below the rate-limit of the coder, and a threshold elevation strategy under rate-limited conditions.

In accordance with an overall coder/decoder system aspect of the present invention, it provides advantageously to employ an improved Huffman-like entropy coder/decoder to further reduce the channel bit rate requirements, or storage capacity for storage applications. The noiseless compression method illustratively used employs Huffman coding along with a frequency-partitioning scheme to efficiently code the frequency samples for L,R,M and S, as may be dictated by the perceptual threshold.

The present invention provides a mechanism for determining the scale factors to be used in quantizing the audio signal (i.e., the MDCT coefficients output from the analysis filter bank) by using an approach different from the prior art,

and while avoiding many of the restriction and costs of prior quantizer/rate-loops. The audio signals quantized pursuant to the present invention introduce less noise and encode into fewer bits than the prior art.

These results are obtained in an illustrative embodiment of the present invention whereby the utilized scale factor, is iteratively derived by interpolating between a scale factor derived from a calculated threshold of hearing at the frequency corresponding to the frequency of the respective spectral coefficient to be quantized and a scale factor derived from the absolute threshold of hearing at said frequency until the quantized spectral coefficients can be encoded within permissible limits.

BRIEF DESCRIPTION OF THE DRAWINGS

FIG. 1 presents an illustrative prior art audio communication/storage system of a type in which aspects of the present invention find application, and provides improvement and extension.

FIG. 2 presents an illustrative perceptual audio coder (PAC) in which the advances and teachings of the present invention find application, and provide improvement and extension.

FIG. 3 shows a representation of a useful masking level difference factor used in threshold calculations.

FIG. 4 presents an illustrative analysis filter bank according to an aspect of the present invention.

FIG. 5(a) through 5(e) illustrate the operation of various window functions.

FIG. 6 is a flow chart illustrating window switching functionality.

FIG. 7 is a block/flow diagram illustrating the overall processing of input signals to derive the output bitstream.

FIG. 8 illustrates certain threshold variations.

FIG. 9 is a flow chart representation of certain bit allocation functionality.

FIG. 10 shows bitstream organization.

FIGS. 11a through 11c illustrate certain Huffman coding operations.

FIG. 12 shows operations at a decoder that are complementary to those for an encoder.

FIG. 13 is a flowchart illustrating certain quantization operations in accordance with an aspect of the present invention.

FIG. 14(a) through 14(g) are illustrative windows for use with the filter bank of FIG. 4.

DETAILED DESCRIPTION

1. Overview

To simplify the present disclosure, the following patents, patent applications and publications are hereby incorporated by reference in the present disclosure as if fully set forth herein: U.S. Pat. No. 5,040,217, issued Aug. 13, 1991 by K. Brandenburg et al, U.S. patent application Ser. No. 07/292,598, entitled Perceptual Coding of Audio Signals, filed Dec. 30, 1988; J. D. Johnston, Transform Coding of Audio Signals Using Perceptual Noise Criteria, IEEE Journal on Selected Areas in Communications, Vol. 6, No. 2 February 1988; International Patent Application (PCT) WO 88/01811, filed Mar. 10, 1988; U.S. patent application Ser. No. 07/491,373, entitled Hybrid Perceptual Coding, filed Mar. 9, 1990, Brandenburg et al, Aspect: Adaptive Spectral Entropy Coding of High Quality Music Signals, AES 90th Convention (1991); Johnston, J., Estimation of Perceptual

Entropy Using Noise Masking Criteria, ICASSP, (1988); J. D. Johnston, Perceptual Transform Coding of Wideband Stereo Signals, ICASSP (1989); E. F. Schroeder and J. J. Platte, "MSC": Stereo Audio Coding with CD-Quality and 256 kBIT/SEC," IEEE Trans. on Consumer Electronics, Vol. CE-33, No. 4, November 1987; and Johnston, Transform Coding of Audio Signals Using Noise Criteria, Vol. 6, No. 2, IEEE J.S.C.A. (February 1988).

For clarity of explanation, the illustrative embodiment of the present invention is presented as comprising individual functional blocks (including functional blocks labeled as "processors"). The functions these blocks represent may be provided through the use of either shared or dedicated hardware, including, but not limited to, hardware capable of executing software. (Use of the term "processor" should not be construed to refer exclusively to hardware capable of executing software.) Illustrative embodiments may comprise digital signal processor (DSP) hardware, such as the AT&T DSP16 or DSP32C, and software performing the operations discussed below. Very large scale integration (VLSI) hardware embodiments of the present invention, as well as hybrid DSP/VLSI embodiments, may also be provided.

FIG. 1 is an overall block diagram of a system useful for incorporating an illustrative embodiment of the present invention. At the level shown, the system of FIG. 1 illustrates systems known in the prior art, but modifications, and extensions described herein will make clear the contributions of the present invention. In FIG. 1, an analog audio signal **101** is fed into a preprocessor **102** where it is sampled (typically at 48 KHz) and converted into a digital pulse code modulation ("PCM") signal **103** (typically 16 bits) in standard fashion. The PCM signal **103** is fed into a perceptual audio coder **104** ("PAC") which compresses the PCM signal and outputs the compressed PAC signal to a communications channel/storage medium **106**. From the communications channel/storage medium the compressed PAC signal (**105**) is fed into a perceptual audio decoder **108** which decompresses the compressed PAC signal and outputs a PCM signal **107** which is representative of the compressed PAC signal **105**. From the perceptual audio decoder, the PCM signal **108** is fed into a post-processor **110** which creates an analog representation of the PCM signal **107**.

An illustrative embodiment of the perceptual audio coder **104** is shown in block diagram form in FIG. 2. As in the case of the system illustrated in FIG. 1, the system of FIG. 2, without more, may equally describe certain prior art systems, e.g., the system disclosed in the Brandenburg, et al U.S. Pat. No. 5,040,217. However, with the extensions and modifications described herein, important new results are obtained. The perceptual audio coder of FIG. 2 may advantageously be viewed as comprising an analysis filter bank **202**, a perceptual model processor **204**, a quantizer/rate-loop processor **206** and an entropy encoder **208**.

The filter bank **202** in FIG. 2 advantageously transforms an input audio signal in time/frequency in such manner as to provide both some measure of signal processing gain (i.e. redundancy extraction) and a mapping of the filter bank inputs in a way that is meaningful in light of the human perceptual system. Advantageously the well-known Modified Discrete Cosine Transform (MDCT) described, e.g., in J. P. Princen and A. B. Bradley, "Analysis/Synthesis Filter Bank Design Based on Time Domain Aliasing Cancellation," IEEE Trans. ASSP, Vol. 34, No. 5, October, 1986, may be adapted to perform such transforming of the input signals.

Features of the MDCT that make it useful in the present context include its critical sampling characteristic, i.e. for

every n samples into the filter bank, n samples are obtained from the filter bank. Additionally, the MDCT typically provides half-overlap, i.e. the transform length is exactly twice the length of the number of samples, n , shifted into the filterbank. The half-overlap provides a good method of dealing with the control of noise injected independently into each filter tap as well as providing a good analysis window frequency response. In addition, in the absence of quantization, the MDCT provides exact reconstruction of the input samples, subject only to a delay of an integral number of samples.

One aspect in which the MDCT is advantageously modified for use in connection with a highly efficient stereophonic audio coder is the provision of the ability to switch the length of the analysis window for signal sections which have strongly non-stationary components in such a fashion that it retains the critically sampled and exact reconstruction properties. The incorporated U.S. patent application by Ferreira and Johnston, entitled, "A METHOD AND APPARATUS FOR THE PERCEPTUAL CODING OF AUDIO SIGNALS," (referred to hereinafter as the "filter bank application") filed of even date with this application, describes a filter bank appropriate for performing the functions of element **202** in FIG. 2.

The perceptual model processor **204** shown in FIG. 2 calculates an estimate of the perceptual importance, noise masking properties, or just noticeable noise floor of the various signal components in the analysis bank. Signals representative of these quantities are then provided to other system elements to provide improved control of the filtering operations and organizing of the data to be sent to the channel or storage medium. Rather than using the critical band by critical band analysis described in J. D. Johnston, "Transform Coding of Audio Signals Using Perceptual Noise Criteria," IEEE J. on Selected Areas in Communications, February 1988, an illustrative embodiment of the present invention advantageously uses finer frequency resolution in the calculation of thresholds. Thus instead of using an overall tonality metric as in the last-cited Johnston paper, a tonality method based on that mentioned in K. Brandenburg and J. D. Johnston, "Second Generation Perceptual Audio Coding: The Hybrid Coder," AES 89th Convention, 1990 provides a tonality estimate that varies over frequency, thus providing a better fit for complex signals.

The psychoacoustic analysis performed in the perceptual model processor **204** provides a noise threshold for the L (Left), R (Right), M (Sum) and S (Difference) channels, as may be appropriate, for both the normal MDCT window and the shorter windows. Use of the shorter windows is advantageously controlled entirely by the psychoacoustic model processor.

In operation, an illustrative embodiment of the perceptual model processor **204** evaluates thresholds for the left and right channels, denoted THR_L and THR_R . The two thresholds are then compared in each of the illustrative **35** coder frequency partitions (56 partitions in the case of an active window-switched block). In each partition where the two thresholds vary between left and right by less than some amount, typically 2 dB, the coder is switched into M/S mode. That is, the left signal for that band of frequencies is replaced by $M=(L+R)/2$, and the right signal is replaced by $S=(L-R)/2$. The actual amount of difference that triggers the last-mentioned substitution will vary with bitrate constraints and other system parameters.

The same threshold calculation used for L and R thresholds is also used for M and S thresholds, with the threshold

calculated on the actual M and S signals. First, the basic thresholds, denoted $BTHR_m$ and MLD_s are calculated. Then, the following steps are used to calculate the stereo masking contribution of the M and S signals.

1. An additional factor is calculated for each of the M and S thresholds. This factor, called MLD_m and MLD_s , is calculated by multiplying the spread signal energy, (as derived, e.g., in J. D. Johnston, "Transform Coding of Audio Signals Using Perceptual Noise Criteria," IEEE J. on Selected Areas in Communications, February 1988; K. Brandenburg and J. D. Johnston, "Second Generation Perceptual Audio Coding: The Hybrid Coder," AES 89th Convention, 1990; and Brandenburg, et al U.S. Pat. No. 5,040,217) by a masking level difference factor shown illustratively in FIG. 3. This calculates a second level of detectability of noise across frequency in the M and S channels, based on the masking level differences shown in various sources.

2. The actual threshold for M (THR_m) is calculated as $THR_m = \max(BTHR_m, \min(BTHR_s, MLD_s))$ and the threshold $m = \max(BTHR_m, \min(BTHR_s, MLD_s))$ and the threshold for S is calculated as $THR_s = \max(BTHR_s, \min(BTHR_m, MLD_m))$.

In effect, the MLD signal substitutes for the BTHR signal in cases where there is a chance of stereo unmasking. It is not necessary to consider the issue of M and S threshold depression due to unequal L and R thresholds, because of the fact that L and R thresholds are known to be equal.

The quantizer/rate loop processor **206** used in the illustrative coder of FIG. 2 takes the outputs from the analysis bank and the perceptual model, and allocates bits, noise, and controls other system parameters so as to meet the required bit rate for the given application. In some example coders this may consist of nothing more than quantization so that the just noticeable difference of the perceptual model is never exceeded, with no (explicit) attention to bit rate; in some coders this may be a complex set of iteration loops that adjusts distortion and bitrate in order to achieve a balance between bit rate and coding noise. Also desirably performed by the rate loop processor **206**, and described in the rate loop application, is the function of receiving information from the quantized analyzed signal and any requisite side information, inserting synchronization and framing information. Again, these same functions are broadly described in the incorporated Brandenburg, et al, U.S. Pat. No. 5,040, 217.

Entropy encoder **208** is used to achieve a further noiseless compression in cooperation with the rate loop processor **206**. In particular, entropy encoder **208**, in accordance with another aspect of the present invention, advantageously receives inputs including a quantized audio signal output from quantizer/rate loop **206**, performs a lossless encoding, on the quantized audio signal, and outputs a compressed audio signal to the communications channel/storage medium **106**.

Illustrative entropy encoder **208** advantageously comprises a novel variation of the minimum-redundancy Huffman coding technique to encode each quantized audio signal. The Huffman codes are described, e.g., in D. A. Huffman, "A Method for the Construction of Minimum Redundancy Codes", Proc. IRE, 40: 1098-1101 (1952) and T. M. Cover and J. A. Thomas, Elements of Information Theory, pp. 92-101 (1991). The useful adaptations of the Huffman codes advantageously used in the context of the coder of FIG. 2 are described in more detail in the incorporated U.S. patent application by J. D. Johnston and J. Reeds (hereinafter the "entropy coder application") filed of

even date with the present application and assigned to the assignee of this application. Those skilled in the data communications arts will readily perceive how to implement alternative embodiments of entropy encoder **208** using other noiseless data compression techniques, including the well-known Lempel-Ziv compression methods.

The use of each of the elements shown in FIG. 2 will be described in greater detail in the context of the overall system functionality; details of operation will be provided for the perceptual model processor **204**.

2.1. The Analysis Filter Bank

The analysis filter bank **202** of the perceptual audio coder **104** receives as input pulse code modulated ("PCM") digital audio signals (typically 16-bit signals sampled at 48 KHz), and outputs a representation of the input signal which identifies the individual frequency components of the input signal. Specifically, an output of the analysis filter bank **202** comprises a Modified Discrete Cosine Transform ("MDCT") of the input signal. See, J. Princen et al, "Sub-band Transform Coding Using Filter Bank Designs Based on Time Domain Aliasing Cancellation," IEEE ICASSP, pp. 2161-2164 (1987).

An illustrative analysis filter bank **202** according to one aspect of the present invention is presented in FIG. 4. Analysis filter bank **202** comprises an input signal buffer **302**, a window multiplier **304**, a window memory **306**, an FFT processor **308**, an MDCT processor **310**, a concatenator **311**, a delay memory **312** and a data selector **314**.

The analysis filter bank **202** operates on frames. A frame is conveniently chosen as the $2N$ PCM input audio signal samples held by input signal buffer **302**. As stated above, each PCM input audio signal sample is represented by M bits. Illustratively, $N=512$ and $M=16$.

Input signal buffer **302** comprises two sections: a first section comprising N samples in buffer locations **1** to N , and a second section comprising N samples in buffer locations $N+1$ to $2N$. Each frame to be coded by the perceptual audio coder **104** is defined by shifting N consecutive samples of the input audio signal into the input signal buffer **302**. Older samples are located at higher buffer locations than newer samples.

Assuming that, at a given time, the input signal buffer **302** contains a frame of $2N$ audio signal samples, the succeeding frame is obtained by (1) shifting the N audio signal samples in buffer locations **1** to N into buffer locations $N+1$ to $2N$, respectively, (the previous audio signal samples in location $N+1$ to $2N$ may be either overwritten or deleted), and (2) by shifting into the input signal buffer **302**, at buffer locations **1** to N , N new audio signal samples from preprocessor **102**. Therefore, it can be seen that consecutive frames contain N samples in common: the first of the consecutive frames having the common samples in buffer locations **1** to N , and the second of the consecutive frames having the common samples in buffer locations $N+1$ to $2N$. Analysis filter bank **202** is a critically sampled system (i.e., for every N audio signal samples received by the input signal buffer **302**, the analysis filter bank **202** outputs a vector of N scalars to the quantizer/rate-loop **206**).

Each frame of the input audio signal is provided to the window multiplier **304** by the input signal buffer **302** so that the window multiplier **304** may apply seven distinct data windows to the frame.

Each data window is a vector of scalars called "coefficients". While all seven of the data windows have $2N$ coefficients (i.e., the same number as there are audio signal samples in the frame), four of the seven only have $N/2$ non-zero coefficients (i.e., one-fourth the number of audio

signal samples in the frame). As is discussed below, the data window coefficients may be advantageously chosen to reduce the perceptual entropy of the output of the MDCT processor 310.

The information for the data window coefficients is stored in the window memory 306. The window memory 306 may illustratively comprise a random access memory (“RAM”), read only memory (“ROM”), or other magnetic or optical media. Drawings of seven illustrative data windows, as applied by window multiplier 304, are presented in FIG. 14. Typical vectors of coefficients for each of the seven data windows presented in FIG. 14. As may be seen in FIG. 14, some of the data window coefficients may be equal to zero.

Keeping in mind that the data window is a vector of $2N$ scalars and that the audio signal frame is also a vector of $2N$ scalars, the data window coefficients are applied to the audio signal frame scalars through point-to-point multiplication (i.e., the first audio signal frame scalar is multiplied by the first data window coefficient, the second audio signal frame scalar is multiplied by the second data window coefficient, etc.). Window multiplier 304 may therefore comprise seven microprocessors operating in parallel, each performing $2N$ multiplications in order to apply one of the seven data window to the audio signal frame held by the input signal buffer 302. The output of the window multiplier 304 is seven vectors of $2N$ scalars to be referred to as “windowed frame vectors”.

The seven windowed frame vectors are provided by window multiplier 304 to FFT processor 308. The FFT processor 308 performs an odd-frequency FFT on each of the seven windowed frame vectors. The odd-frequency FFT is an Discrete Fourier Transform evaluated at frequencies:

$$\frac{kf_H}{2N}$$

where $k=1,3,5, \dots, 2N$, and f_N equals one half the sampling rate. The illustrative FFT processor 308 may comprise seven conventional decimation-in-time FFT processors operating in parallel, each operating on a different windowed frame vector. An output of the FFT processor 308 is seven vectors of $2N$ complex elements, to be referred to collectively as “FFT vectors”.

FFT processor 308 provides the seven FFT vectors to both the perceptual model processor 204 and the MDCT processor 310. The perceptual model processor 204 uses the FFT vectors to direct the operation of the data selector 314 and the quantizer/rate-loop processor 206. Details regarding the operation of data selector 314 and perceptual model processor 204 are presented below.

MDCT processor 310 performs an MDCT based on the real components of each of the seven FFT vectors received from FFT processor 308. MDCT processor 310 may comprise seven microprocessors operating in parallel. Each such microprocessor determines one of the seven “MDCT vectors” of N real scalars based on one of the seven respective FFT vectors. For each FFT vector, $F(k)$, the resulting MDCT vector, $X(k)$, is formed as follows:

$$X(k) = \text{Re}[F(k)] \cos \left[\frac{\pi(2k+1)(1+N)}{4N} \right] \quad 1 \leq k \leq N.$$

The procedure need run k only to N , not $2N$, because of redundancy in the result. To wit, for $N < k \leq 2N$:

$$X(k) = -X(2N-k).$$

MDCT processor 310 provides the seven MDCT vectors to concatenator 311 and delay memory 312.

As discussed above with reference to window multiplier 304, four the seven data windows have $N/2$ non-zero coefficients (see FIGS. 4c–f). This means that four of the windowed frame vectors contain only $N/2$ non-zero values.

Therefore, the non-zero values of these four vectors may be concatenated into a single vector of length $2N$ by concatenator 311 upon output from MDCT processor 310. The resulting concatenation of these vectors is handled as a single vector for subsequent purposes. Thus, delay memory 312 is presented with four MDCT vectors, rather than seven.

Delay memory 312 receives the four MDCT vectors from MDCT processor 310 and concatenator 311 for the purpose of providing temporary storage. Delay memory 312 provides a delay of one audio signal frame (as defined by input signal buffer 302) on the flow of the four MDCT vectors through the filter bank 202. The delay is provided by (i) storing the two most recent consecutive sets of MDCT vectors representing consecutive audio signal frames and (ii) presenting as input to data selector 314 the older of the consecutive sets of vectors. Delay memory 312 may comprise random access memory (RAM) of size:

$$M \times 2 \times 4 \times N$$

where 2 is the number of consecutive sets of vectors, 4 is the number of vectors in a set, N is the number of elements in an MDCT vector, and M is the number of bits used to represent an MDCT vector element.

Data selector 314 selects one of the four MDCT vectors provided by delay memory 312 to be output from the filter bank 202 to quantizer/rate-loop 206. As mentioned above, the perceptual model processor 204 directs the operation of data selector 314 based on the FFT vectors provided by the FFT processor 308. Due to the operation of delay memory 312, the seven FFT vectors provided to the perceptual model processor 204 and the four MDCT vectors concurrently provided to data selector 314 are not based on the same audio input frame, but rather on two consecutive input signal frames—the MDCT vectors based on the earlier of the frames, and the FFT vectors based on the later of the frames. Thus, the selection of a specific MDCT vector is based on information contained in the next successive audio signal frame. The criteria according to which the perceptual model processor 204 directs the selection of an MDCT vector is described in Section 2.2, below.

For purposes of an illustrative stereo embodiment, the above analysis filterbank 202 is provided for each of the left and right channels.

2.2. The Perceptual Model Processor

A perceptual coder achieves success in reducing the number of bits required to accurately represent high quality audio signals, in part, by introducing noise associated with quantization of information bearing signals, such as the MDCT information from the filter bank 202. The goal is, of course, to introduce this noise in an imperceptible or benign way. This noise shaping is primarily a frequency analysis instrument, so it is convenient to convert a signal into a spectral representation (e.g., the MDCT vectors provided by filter bank 202), compute the shape and amount of the noise that will be masked by these signals and injecting it by quantizing the spectral values. These and other basic operations are represented in the structure of the perceptual coder shown in FIG. 2.

The perceptual model processor 204 of the perceptual audio coder 104 illustratively receives its input from the analysis filter bank 202 which operates on successive frames. The perceptual model processor inputs then typically comprise seven Fast Fourier Transform (FFT) vectors

from the analysis filter bank **202**. These are the outputs of the FFT processor **308** in the form of seven vectors of $2N$ complex elements, each corresponding to one of the windowed frame vectors.

In order to mask the quantization noise by the signal, one must consider the spectral contents of the signal and the duration of a particular spectral pattern of the signal. These two aspects are related to masking in the frequency domain where signal and noise are approximately steady state—given the integration period of the hearing system— and also with masking in the time domain where signal and noise are subjected to different cochlear filters. The shape and length of these filters are frequency dependent.

Masking in the frequency domain is described by the concept of simultaneous masking. Masking in the time domain is characterized by the concept of premasking and postmasking. These concepts are extensively explained in the literature; see, for example, E. Zwicker and H. Fastl, "Psychoacoustics, Facts, and Models," Springer-Verlag, 1990. To make these concepts useful to perceptual coding, they are embodied in different ways.

Simultaneous masking is evaluated by using perceptual noise shaping models. Given the spectral contents of the signal and its description in terms of noise-like or tone-like behavior, these models produce an hypothetical masking threshold that rules the quantization level of each spectral component. This noise shaping represents the maximum amount of noise that may be introduced in the original signal without causing any perceptible difference. A measure called the PERCEPTUAL ENTROPY (PE) uses this hypothetical masking threshold to estimate the theoretical lower bound of the bitrate for transparent encoding. J. D. Johnston, "Estimation of Perceptual Entropy Using Noise Masking Criteria," ICASSP, 1989.

Premasking characterizes the (in)audibility of a noise that starts some time before the masker signal which is louder than the noise. The noise amplitude must be more attenuated as the delay increases. This attenuation level is also frequency dependent. If the noise is the quantization noise attenuated by the first half of the synthesis window, experimental evidence indicates the maximum acceptable delay to be about 1 millisecond.

This problem is very sensitive and can conflict directly with achieving a good coding gain. Assuming stationary conditions—which is a false premiss—The coding gain is bigger for larger transforms, but, the quantization error spreads till the beginning of the reconstructed time segment. So, if a transform length of 1024 points is used, with a digital signal sampled at a rate of 48000 Hz, the noise will appear at most 21 milliseconds before the signal. This scenario is particularly critical when the signal takes the form of a sharp transient in the time domain commonly known as an "attack". In this case the quantization noise is audible before the attack. The effect is known as pre-echo.

Thus, a fixed length filter bank is not a good perceptual solution nor a signal processing solution for non-stationary regions of the signal. It will be shown later that a possible way to circumvent this problem is to improve the temporal resolution of the coder by reducing the analysis/synthesis window length. This is implemented as a window switching mechanism when conditions of attack are detected. In this way, the coding gain achieved by using a long analysis/synthesis window will be affected only when such detection occurs with a consequent need to switch to a shorter analysis/synthesis window.

Postmasking characterizes the (in)audibility of a noise when it remains after the cessation of a stronger masker

signal. In this case the acceptable delays are in the order of 20 milliseconds. Given that the bigger transformed time segment lasts 21 milliseconds (1024 samples), no special care is needed to handle this situation.

5 WINDOW SWITCHING

The PERCEPTUAL ENTROPY (PE) measure of a particular transform segment gives the theoretical lower bound of bits/sample to code that segment transparently. Due to its memory properties, which are related to premasking protection, this measure shows a significant increase of the PE value to its previous value—related with the previous segment—when some situations of strong non-stationarity of the signal (e.g. an attack) are presented. This important property is used to activate the window switching mechanism in order to reduce pre-echo. This window switching mechanism is not a new strategy, having been used, e.g., in the ASPEC coder, described in the ISO/MPEG Audio Coding Report, 1990, but the decision technique behind it is new using the PE information to accurately localize the non-stationarity and define the right moment to operate the switch.

Two basic window lengths: 1024 samples and 256 samples are used. The former corresponds to a segment duration of about 21 milliseconds and the latter to a segment duration of about 5 milliseconds. Short windows are associated in sets of 4 to represent as much spectral data as a large window (but they represent a "different" number of temporal samples). In order to make the transition from large to short windows and vice-versa it proves convenient to use two more types of windows. A START window makes the transition from large (regular) to short windows and a STOP window makes the opposite transition, as shown in FIG. 5b. See the above-cited Princen reference for useful information on this subject. Both windows are 1024 samples wide. They are useful to keep the system critically sampled and also to guarantee the time aliasing cancellation process in the transition region.

In order to exploit interchannel redundancy and irrelevancy, the same type of window is used for RIGHT and LEFT channels in each segment.

The stationarity behavior of the signal is monitored at two levels. First by large regular windows, then if necessary, by short windows. Accordingly, the PE of large (regular) window is calculated for every segment while the PE of short windows are calculated only when needed. However, the tonality information for both types is updated for every segment in order to follow the continuous variation of the signal.

Unless stated otherwise, a segment involves 1024 samples which is the length of a large regular window.

The diagram of FIG. 5a represents all the monitoring possibilities when the segment from the point $N/2$ till the point $3N/2$ is being analysed. Related to the diagram of FIG. 5 is the flowchart of FIG. 6 which describes the monitoring sequence and decision technique. We need to keep in buffer three halves of a segment in order to be able to insert a START window prior to a sequence of short windows when necessary. FIGS. 5a–e explicitly considers the 50% overlap between successive segments.

The process begins by analysing a "new" segment with 512 new temporal samples (the remaining 512 samples belong to the previous segment). As shown in FIG. 6, the PE of this new segment and the differential PE to the previous segment are calculated (**601**). If the latter value reaches a predefined threshold (**602**), then the existence of a non-stationarity inside the current segment is declared and details are obtained by processing four short windows with posi-

tions as represented in FIG. 5a. The PE value of each short window is calculated (603) resulting in the ordered sequence: PE1, PE2, PE3 and PE4. From these values, the exact beginning of the strong non-stationarity of the signal is deduced. Only five locations are possible, identified in FIG. 5a as L1, L2, L3, L4 and L5. As it will become evident, if the non-stationarity had occurred somewhere from the point N/2 till the point 15N/16, that situation would have been detected in the previous segment. It follows that the PE1 value does not contain relevant information about the stationarity of the current segment. The average PE of the short windows is compared with the PE of the large window of the same segment (605). A smaller PE reveals a more efficient coding situation. Thus if the former value is not smaller than the latter, then we assume that we are facing a degenerate situation and the window switching process is aborted.

It has been observed that for short windows the information about stationarity lies more on its PE value than on the differential to the PE value of the precedent window. Accordingly, the first window that has a PE value larger than a predefined threshold is detected. PE2 is identified with location L1, PE3 with L2 and PE4 with location L3. In either case, a START window (608) is placed before the current segment that will be coded with short windows. A STOP window is needed to complete the process (616). There are, however, two possibilities. If the identified location where the strong non-stationarity of the signal begins is L1 or L2 then, this is well inside the short window sequence, no coding artifacts result and the coding sequence is depicted in FIG. 5b. If the location is L4 (612), then, in the worst situation, the non-stationarity may begin very close to the right edge of the last short window. Previous results have consistently shown that placing a STOP window—in coding conditions—in these circumstances degrades significantly the reconstruction of the signal in this switching point. For this reason, another set of four short windows is placed before a STOP window (614). The resulting coding sequence is represented in FIG. 5e.

If none of the short PEs is above the threshold, the remaining possibilities are L4 or L5. In this case, the problem lies ahead of the scope of the short window sequence and the first segment in the buffer may be immediately coded using a regular large window.

To identify the correct location, another short window must be processed. It is represented in FIG. 5a by a dotted curve and its PE value, PE1_{n+1}, is also computed. As it is easily recognized, this short window already belongs to the next segment. If PE1_{n+1} is above the threshold (611), then, the location is L4 and, as depicted in FIG. 5c, a START window (613) may be followed by a STOP window (615). In this case the spread of the quantization noise will be limited to the length of a short window, and a better coding gain is achieved. In the rare situation of the location being L5, then the coding is done according to the sequence of FIG. 5d. The way to prove that in this case that is right solution is by confirming that PE2_{n+1} will be above the threshold. PE2_{n+1} is the PE of the short window (not represented in FIG. 5) immediately following the window identified with PE1_{n+1}.

As mentioned before for each segment, RIGHT and LEFT channels use the same type of analysis/synthesis window. This means that a switch is done for both channels when at least one channel requires it.

It has been observed that for low bitrate applications the solution of FIG. 5c, although representing a good local psychoacoustic solution, demands an unreasonably large

number of bits that may adversely affect the coding quality of subsequent segments. For this reason, that coding solution may eventually be inhibited.

It is also evident that the details of the reconstructed signal when short windows are used are closer to the original signal than when only regular large window are used. This is so because the attack is basically a wide bandwidth signal and may only be considered stationary for very short periods of time. Since short windows have a greater temporal resolution than large windows, they are able to follow and reproduce with more fidelity the varying pattern of the spectrum. In other words, this is the difference between a more precise local (in time) quantization of the signal and a global (in frequency) quantization of the signal.

The final masking threshold of the stereophonic coder is calculated using a combination of monophonic and stereophonic thresholds. While the monophonic threshold is computed independently for each channel, the stereophonic one considers both channels.

The independent masking threshold for the RIGHT of the LEFT channel is computed using a psychoacoustic model that includes an expression for tone masking noise and noise masking tone. The latter is used as a conservative approximation for a noise masking noise expression. The monophonic threshold is calculated using the same procedure as previous work. In particular, a tonality measure considers the evolution of the power and the phase of each frequency coefficient across the last three segments to identify the signal as being more tone—like or noise—like. Accordingly, each psychoacoustic expression is more or less weighted than the other. These expressions found in the literature were updated for better performance. They are defined as:

$$\begin{aligned} \text{TMN}_{\text{dB}} &= 19.5 + \text{bark} \frac{18.0}{26.0} \\ \text{NMT}_{\text{dB}} &= 6.56 - \text{bark} \frac{3.06}{26.0} \end{aligned}$$

where bark is the frequency in Bark scale. The scale is related to what we may call the cochlear filters or critical bands which, in turn, are identified with constant length segments of the basilar membrane. The final threshold is adjusted to consider absolute thresholds of masking and also to consider a partial premasking protection.

A brief description of the complete monophonic threshold calculation follows. Some terminology must be introduced in order to simplify the description of the operations involved.

The spectrum of each segment is organized in three different ways, each one following a different purpose.

1. First, it may be organized in partitions. Each partition has associated one single Bark value. These partitions provide a resolution of approximately either one MDCT line or 1/3 of a critical band, whichever is wider. At low frequencies a single line of the MDCT will constitute a coder partition. At high frequencies, many lines will be combined into one coder partition. In this case the Bark value associated is the median Bark point of the partition. This partitioning of the spectrum is necessary to insure an acceptable resolution for the spreading function. As will be shown later, this function represents the masking influence among neighboring critical bands.

2. Secondly, the spectrum may be organized in bands. Bands are defined by a parameter file. Each band groups a number of spectral lines that are associated with a single scale factor that results from the final masking threshold vector.

15

3. Finally, the spectrum may also be organized in sections. It will be shown later that sections involve an integer number of bands and represent a region of the spectrum coded with the same Huffman code book.

Three indices for data values are used. These are:

ω →indicates that the calculation is indexed by frequency in the MDCT line domain.

b →indicates that the calculation is indexed in the threshold calculation partition domain. In the case where we do a convolution or sum in that domain, bb will be used as the summation variable.

n →indicates that the calculation is indexed in the coder band domain.

Additionally some symbols are also used:

1. The index of the calculation partition, b .

2. The lowest frequency line in the partition, ω_{low_b} .

3. The highest frequency line in the partition, ω_{high_b} .

4. The median bark value of the partition, $bval_b$.

5. The value for tone masking noise (in dB) for the partition, TMN_b .

6. The value for noise masking tone (in dB) for the partition, NMT_b .

Several points in the following description refer to the "spreading function". It is calculated by the following method:

$$tmpx=1.05(j-i),$$

Where i is the bark value of the signal being spread, j the bark value of the band being spread into, and $tmpx$ is a temporary variable.

$$x=8\text{minimum}((tmpx-0.5)^2-2(tmpx-0.5),0)$$

Where x is a temporary variable, and $\text{minimum}(a,b)$ is a function returning the more negative of a or b .

$$tmpy=15.811389+7.5(tmpx+0.474)-17.5(1.+(tmpx+0.474)^2)^{0.5}$$

where $tmpy$ is another temporary variable.

$$\text{if } (tmpy < -100) \text{ then } [\text{sprdngf}(i, j) = 0] \text{ else } \left[\text{sprdngf}(i, j) = 10^{\frac{(x+tmpy)}{10}} \right].$$

Steps in Threshold Calculation

The following steps are the necessary steps for calculation the SMR_n used in the coder.

1. Concatenate 512 new samples of the input signal to from another 1024 samples segment. Please refer to FIG. 5a.

2. Calculate the complex spectrum of the input signal using the O-FFT as described in 2.0 and using a sine window.

3. Calculate a predicted r and ϕ .

The polar representation of the transform is calculated r_ω and ϕ_ω represent the magnitude and phase components of a spectral line of the transformed segment.

A predicted magnitude, \hat{r}_ω , and phase $\hat{\phi}_\omega$, are calculated from the preceding two threshold calculation blocks' r and ϕ :

$$\hat{r}_\omega=2r_{107(t-1)}-r_\omega(t-2)$$

$$\hat{\phi}_\omega=2\phi_{107(t-1)}-\phi_\omega(t-2)$$

where t represents the current block number, $t-1$ indexes the previous block's data, and $t-2$ indexes the data from the threshold calculation block before that,

16

4. Calculate the unpredictability measure c_ω , the unpredictability measure, is:

$$c_\omega = \frac{\left((r_\omega \cos \phi_\omega - \hat{r}_\omega \cos \hat{\phi}_\omega)^2 + (r_\omega \sin \phi_\omega - \hat{r}_\omega \sin \hat{\phi}_\omega)^2 \right)^5}{r_\omega + \text{abs}(\hat{r}_\omega)}$$

5. Calculate the energy and unpredictability in the threshold calculation partitions.

The energy in each partition, e_b , is:

$$e_b = \sum_{\omega=\omega_{low_b}}^{\omega_{high_b}} r_\omega^2$$

and the weighted unpredictability, c_b , is:

$$c_b = \sum_{\omega=\omega_{low_b}}^{\omega_{high_b}} r_\omega^2 c_\omega$$

6. Convolve the partitioned energy and unpredictability with the spreading function.

$$ecb_b = \sum_{bb=1}^{bmax} e_{bb} \text{sprdngf}(bval_{bb}, bval_b)$$

$$ct_b = \sum_{bb=1}^{bmax} c_{bb} \text{sprdngf}(bval_{bb}, bval_b)$$

Because ct_b is weighted by the signal energy, it must be renormalized to cb_b .

$$cb_b = \frac{ct_b}{ecb_b}$$

At the same time, due to the non-normalized nature of the spreading function, ecb_b should be renormalized and the normalized energy en_b , calculated.

$$en_b = \frac{ecb_b}{rnorm_b}$$

The normalization coefficient, $rnorm_b$ is:

$$rnorm_b = \frac{1}{\sum_{bb=0}^{bmax} \text{sprdngf}(bval_{bb}, bval_b)}$$

7. Convert cb_b to tb_b .

$$tb_b = -0.299 - 0.43 \log_\alpha(cb_b)$$

Each tb_b is limited to the range of $0 \leq tb_b \leq 1$.

8. Calculate the required SNR in each partition.

$$TMN_b = 19.5 + bval_b \frac{18.0}{26.0}$$

$$NMT_b = 6.56 - bval_b \frac{3.06}{26.0}$$

Where TMN_b is the tone masking noise in dB and NMT_b is the noise masking tone value in dB.

17

The required signal to noise ratio, SNR_b , is:

$$SNR_b = tb_b \cdot TMN_b + (1 - tb_b) \cdot NMT_b$$

9. Calculate the power ratio.

The power ratio, bc_b , is:

$$bc_b = 10^{-\frac{SNR_b}{10}}$$

10. Calculation of actual energy threshold, nb_b .

$$nb_b = en_b \cdot bc_b$$

11. Spread the threshold energy over MDCT lines, yielding nb_ω

$$nb_\omega = \frac{nb_b}{\omega_{high_b} - \omega_{low_b} + 1}$$

12. Include absolute thresholds, yielding the final energy threshold of audibility, thr_ω

$$thr_\omega = \max(nb_\omega, abstr_\omega)$$

The dB values of $abstr$ shown in the "Absolute Threshold Tables" are relative to the level that a sine wave of $\pm 1/2$ lsb has in the MDCT used for threshold calculation. The dB values must be converted into the energy domain after considering the MDCT normalization actually used.

13. Pre-echo control

14. Calculate the signal to mask ratios, SMR_n .

The table of "Bands of the Coder" shows

1. The index, n , of the band.

2. The upper index, ω_{high}_n , of the band n . The lower index, ω_{low}_n , is computed from the previous band as $\omega_{high}_{n-1} + 1$.

To further classify each band, another variable is created. The width index, $width_n$, will assume a value $width_n = 1$ if n is a perceptually narrow band, and $width_n = 0$ if n is a perceptually wide band. The former case occurs if

$$bval_{\omega_{high}_b} - bval_{\omega_{low}_b} < bbandlength$$

$bbandlength$ is a parameter set in the initialization routine. Otherwise the latter case is assumed.

Then, if ($width_n = 1$), the noise level in the coder band, $nband_n$ is calculated as:

$$nband_n = \frac{\sum_{\omega=\omega_{low}_n}^{\omega_{high}_n} thr_\omega}{\omega_{high}_n - \omega_{low}_n + 1}$$

else,

$$nband_n = \text{minimum}(thr_{\omega_{low}_n}, \dots, thr_{\omega_{high}_n})$$

Where, in this case, $\text{minimum}(a, \dots, z)$ is a function returning the most negative or smallest positive argument of the arguments $a \dots z$.

18

The ratios to be sent to the decoder, SMR_n , are calculated as:

$$SMR_n = 10 \cdot \log_{10} \left(\frac{[12.0 * nband_n]^{0.5}}{\text{minimum}(abstr)} \right)$$

It is important to emphasize that since the tonality measure is the output of a spectrum analysis process, the analysis window has a sine form for all the cases of large or short segments. In particular, when a segment is chosen to be coded as a START or STOP window, its tonality information is obtained considering a sine window; the remaining operations, e.g. the threshold calculation and the quantization of the coefficients, consider the spectrum obtained with the appropriate window.

STEREOPHONIC THRESHOLD

The stereophonic threshold has several goals. It is known that most of the time the two channels sound "alike". Thus, some correlation exists that may be converted in coding gain. Looking into the temporal representation of the two channels, this correlation is not obvious. However, the spectral representation has a number of interesting features that may advantageously be exploited. In fact, a very practical and useful possibility is to create a new basis to represent the two channels. This basis involves two orthogonal vectors, the vector SUM and the vector DIFFERENCE defined by the following linear combination:

$$\begin{bmatrix} \text{SUM} \\ \text{DIF} \end{bmatrix} = \frac{1}{2} \begin{bmatrix} 1 & 1 \\ 1 & -1 \end{bmatrix} \cdot \begin{bmatrix} \text{RIGHT} \\ \text{LEFT} \end{bmatrix}$$

These vectors, which have the length of the window being used, are generated in the frequency domain since the transform process is by definition a linear operation. This has the advantage of simplifying the computational load.

The first goal is to have a more decorrelated representation of the two signals. The concentration of most of the energy in one of these new channels is a consequence of the redundancy that exists between RIGHT and LEFT channels and on average, leads always to a coding gain.

A second goal is to correlate the quantization noise of the RIGHT and LEFT channels and control the localization of the noise or the unmasking effect. This problem arises if RIGHT and LEFT channels are quantized and coded independently. This concept is exemplified by the following context: supposing that the threshold by masking for a particular signal has been calculated, two situations may be created. First, we add to the signal an amount of noise that corresponds to the threshold. If we present this same signal with this same noise to the two ears then the noise is masked. However, if we add an amount of noise that corresponds to the threshold to the signal and present this combination to one ear; do the same operation for the other ear but with noise uncorrelated with the previous one, then the noise is not masked. In order to achieve masking again, the noise at both ears must be reduced by a level given by the masking level differences (MLD).

The unmasking problem may be generalized to the following form: the quantization noise is not masked if it does not follow the localization of the masking signal. Hence, in particular, we may have two limit cases: center localization of the signal with unmasking more noticeable on the sides of the listener and side localization of the signal with unmasking more noticeable on the center line.

The new vectors SUM and DIFFERENCE are very convenient because they express the signal localized on the

center and also on both sides of the listener. Also, they enable to control the quantization noise with center and side image. Thus, the unmasking problem is solved by controlling the protection level for the MLD through these vectors. Based on some psychoacoustic information and other experiments and results, the MLD protection is particularly critical for very low frequencies to about 3 KHz. It appears to depend only on the signal power and not on its tonality properties. The following expression for the MLD proved to give good results:

$$MLD_{dB}(i) = 25.5 \left[\cos \frac{\pi b(i)}{32.0} \right]^2$$

where i is the partition index of the spectrum (see [7]), and $b(i)$ is the bark frequency of the center of the partition i . This expression is only valid for $b(i) \leq 16.0$ i.e. for frequencies below 3 KHz. The expression for the MLD threshold is given by:

$$THR_{MLD}(i) = C(i) 10^{-\frac{MLD_{dB}(i)}{10}}$$

$C(i)$ is the spread signal energy on the basilar membrane, corresponding only to the partition i .

A third and last goal is to take advantage of a particular stereophonic signal image to extract irrelevance from directions of the signal that are masked by that image. In principle, this is done only when the stereo image is strongly defined in one direction, in order to not compromise the richness of the stereo signal. Based on the vectors SUM and DIFFERENCE, this goal is implemented by positioning the following two dual principles:

1. If there is a strong depression of the signal (and hence of the noise) on both sides of the listener, then an increase of the noise on the middle line (center image) is perceptually tolerated. The upper bound is the side noise.
2. If there is a strong localization of the signal (and hence of the noise) on the middle line, then an increase of the (correlated) noise on both sides is perceptually tolerated. The upper bound is the center noise.

However, any increase of the noise level must be corrected by the MLD threshold.

According to these goals, the final stereophonic threshold is computed as follows. First, the thresholds for channels SUM and DIFFERENCE are calculated using the monophonic models for noise-masking-tone and tone-masking-noise. The procedure is exactly the one presented in pages 25 and 26. At this point we have the actual energy threshold per band, nb_b for both channels. By convenience, we call then $THR_{n_{SUM}}$ and $THR_{n_{DIF}}$, respectively for the channel SUM and the channel DIFFERENCE.

Secondly, the MLD threshold for both channels i.e. $THR_{n_{MLD,SUM}}$ and $THR_{n_{MLD,DIF}}$, are also calculated by:

$$THR_{n_{MLD,SUM}} = en_{b,SUM} 10^{-\frac{MLD_{dB}}{10}}$$

$$THR_{n_{MLD,DIF}} = en_{b,DIF} 10^{-\frac{MLD_{dB}}{10}}$$

The MLD protection and the stereo irrelevance are considered by computing:

$$nthr_{SUM} = \text{MAX}[THR_{n_{SUM}}, \text{MIN}(THR_{n_{DIF}}, THR_{n_{MLD,DIF}})]$$

$$nthr_{DIF} = \text{MAX}[THR_{n_{DIF}}, \text{MIN}(THR_{n_{SUM}}, THR_{n_{MLD,SUM}})]$$

After these operations, the remaining steps after the 11th, as presented in 3.2 are also taken for both channels. In essence, these last thresholds are further adjusted to consider the absolute threshold and also a partial premasking protection. It must be noticed that this premasking protection was simply adopted from the monophonic case. It considers a monaural time resolution of about 2 milliseconds. However, the binaural time resolution is as accurate as 6 microseconds! To conveniently code stereo signals with relevant stereo image based on interchannel time differences, is a subject that needs further investigation.

STEREOPHONIC CODER

The simplified structure of the stereophonic coder allows for the encoding of the stereo signals which are subsequently decoded by the stereophonic decoder which, is presented in FIG. 12. For each segment of data being analysed, detailed information about the independent and relative behavior of both signal channels may be available through the information given by large and short transforms. This information is used according to the necessary number of steps needed to code a particular segment. These steps involve essentially the selection of the analysis window, the definition on a band basis of the coding mode (R/L or S/D), the quantization (704) and Huffman coding (705) of the coefficients (708) and scale factors (707) and finally, the bitstream composing (706) with a bit stream organization as depicted in FIG. 10. Coding Mode Selection

When a new segment is read, the tonality updating for large and short analysis windows is done. Monophonic thresholds and the PE values are calculated according to the technique described previously. This gives the first decision about the type of window to be used for both channels.

Once the window sequence is chosen, an orthogonal coding decision is then considered. It involves the choice between independent coding of the channels, mode RIGHT/LEFT (R/L) or joint coding using the SUM and DIFFERENCE channels (S/D). This decision is taken on a band basis of the coder. This is based on the assumption that the binaural perception is a function of the output of the same critical bands at the two ears. If the threshold at the two channels is very different, then there is no need for MLD protection and the signals will not be more decorrelated if the channels SUM and DIFFERENCE are considered. If the signals are such that they generate a stereo image, then a MLD protection must be activated and additional gains may be exploited by choosing the S/D coding mode. A convenient way to detect this latter situation is by comparing the monophonic threshold between RIGHT and LEFT channels. If the thresholds in a particular band do not differ by more than a predefined value, e.g. 2 dB, then the S/D coding mode is chosen. Otherwise the independent mode R/L is assumed. Associated with each band is a one bit flag that specifies the coding mode of that band and that must be transmitted to the decoder as side information. From now on it is called a coding mode flag.

The coding mode decision is adaptive in time since for the same band it may differ for subsequent segments, and is also adaptive in frequency since for the same segment, the coding mode for subsequent bands may be different. An illustration of a coding decision is given in FIG. 13. This illustration is valid for long and also short segments.

At this point it is clear that since the window switching mechanism involves only monophonic measures, the maximum number of PE measures per segment is 10 (2 channels * [1 large window + 4 short windows]). However, the maximum number of thresholds that we may need to compute per segment is 20 and therefore 20 tonality measures must be

always updated per segment (4 channels *[1 large window+4 short windows]).

Bitrate Adjustment

It was previously said that the decisions for window switching and for coding mode selection are orthogonal in the sense that they do not depend on each other. Independent to these decisions is also the final step of the coding process that involves quantization, Huffman coding and bitstream composing: i.e. there is no feedback path. This fact has the advantage of reducing the whole coding delay to a minimum value (1024/48000=21.3 milliseconds) and also to avoid instabilities due to unorthodox coding situations.

The quantization process effects both spectral and coefficients and scale factors. Spectral coefficients are clustered in bands, each band having the same step size or scale factor. Each step size is directly computed from the masking threshold corresponding to its band. The quantized values, which are integer numbers, are then converted to variable word length of Huffman codes. The total number of bits to code the segment, considering additional fields of the bitstream, is computed. Since the bitrate must be kept constant, the quantization process must be iteratively done till that number of bits is within predefined limits. After the number of bits needed to code the whole segment, considering the basic masking threshold, the degree of adjustment is dictated by a buffer control unit. This control unit shares the deficit or credit of additional bits among several segments, according to the needs of each one.

The technique of the bitrate adjustment routine is represented by the flowchart of FIG. 9. It may be seen that after the total number of available bits to be used by the current segment is computed, an iterative procedure tries to find a factor α such that if all the initial thresholds are multiplied by this factor, the final total number of bits is smaller than and within an error δ of the available number of bits. Even if the approximation curve is so hostile that α is not found within the maximum number of iterations, one acceptable solution is always available.

The main steps of this routine are depicted in FIG. 7 and FIG. 9 as follows. First, an interval including the solution is found. Then, a loop seeks to rapidly converge to the best solution. At each iteration, the best solution is updated. Thus, the total number of bits to represent the present whole segment (710) using the basic masking threshold is evaluated. Next, the total number of bits available to be used by the current segment is computed based on the current buffer status from the buffer control (703). A comparison (903) is made between the total number of bits available in the buffer and the calculated total number of bits to represent the current whole segment. If the required number of bits is less than the available number of bits in the buffer, a further comparison is made to determine if the final total number of bits required is within an error factor of the available number of bits (904). If within the error factor, the total number of bits required to represent the current whole segment are transmitted (916) to the entropy encoder (208). If not within the error factor, an evaluation is done based upon the number of bits required to represent the whole segment at the absolute threshold values (905). If the required number of bits to represent the whole segment at the absolute threshold values are less than the total number of bits available (906) they are transmitted (916) to the entropy encoder (208).

If at this point, neither the basic masking threshold nor absolute thresholds have provided an acceptable bit representation of the whole segment, an iterative procedure (as shown in 907 through 915) is employed to establish the interpolation factor used as a multiplier and discussed pre-

viously. If successful, the iterative procedure will establish a bit representation of the whole segment which is within the buffer limit and associated error factor. Otherwise, after reaching a maximum number of iterations (908) the iterative process will return the last best approximation (915) of the whole segment as output (916).

In order to use the same procedure for segments coded with large and short windows, in this latter case, the coefficients of the 4 short windows are clustered by concatenating homologue bands. Scale factors are clustered in the same.

The bitrate adjustment routine (704) calls another routine that computes the total number of bits to represent all the Huffman coded words (705) (coefficients and scale factors). This latter routine does a spectrum partitioning according to the amplitude distribution of the coefficients. The goal is to assign predefined Huffman code books to sections of the spectrum. Each section groups a variable number of bands and its coefficients are Huffman coded with a convenient book. The limits of the section and the reference of the code book must be sent to the decoder as side information.

The spectrum partitioning is done using a minimum cost strategy. The main steps are as follows. First, all possible sections are defined -the limit is one section per band- each one having the code book that best matches the amplitude distribution of the coefficients within that section. As the beginning and the end of the whole spectrum is known, if K is the number of sections, there are $K-1$ separators between sections. The price to eliminate each separator is computed. The separator that has a lower price is eliminated (initial prices may be negative). Prices are compared again before the next iteration. This process is repeated till a maximum allowable number of sections is obtained and the smallest price to eliminate another separator is higher than a predefined value.

Aspects of the processing accomplished by quantizer/rate-loop 206 in FIG. 2 will now be presented. In the prior art, rate-loop mechanisms have contained assumptions related to the monophonic case. With the shift from monophonic to stereophonic perceptual coders, the demands placed upon the rate-loop are increased.

The inputs to quantizer/rate-loop 206 in FIG. 2 comprise spectral coefficients (i.e., the MDCT coefficients) derived by analysis filter bank 202, and outputs of perceptual model 204, including calculated thresholds corresponding to the spectral coefficients.

Quantizer/rate-loop 206 quantizes the spectral information based, in part, on the calculated thresholds and the absolute thresholds of hearing and in doing so provides a bitstream to entropy encoder 208. The bitstream includes signals divided into three part: (1) a first part containing the standardized side information; (2) a second part containing the scaling factors for the 35 or 56 bands and additional side information used for so-called adaptive-window switching, when used (the length of this part can vary depending on information in the first part) and (3) a third part comprising the quantized spectral coefficients.

A "utilized scale factor", Δ , is iteratively derived by interpolating between a calculated scale factor and a scale factor derived from the absolute threshold of hearing at the frequency corresponding to the frequency of the respective spectral coefficient to be quantized until the quantized spectral coefficients can be encoded within permissible limits.

An illustrative embodiment of the present invention can be seen in FIG. 13. As shown at 1301 quantizer/rate-loop receives a spectral coefficient, C_y , and an energy threshold,

E, corresponding to that spectral coefficient. A “threshold scale factor”, Δ_o is calculated by

$$\Delta_o = \sqrt{12E}$$

An “absolute scale factor”, Δ_A , is also calculated based upon the absolute threshold of hearing (i.e., the quietest sound that can be heard at the frequency corresponding to the scale factor). Advantageously, an interpolation constant, α , and interpolation bounds α_{high} and α_{low} are initialized to aid in the adjustment of the utilized scale factor.

$$\alpha_{high}=1$$

$$\alpha_{low}=0$$

$$\alpha=\alpha_{high}$$

Next, as shown in **1305**, the utilized scale factor is determined from:

$$\Delta=\Delta_o^\alpha \times \Delta_A^{(1-\alpha)}$$

Next, as shown in **1307**, the utilized scale factor is itself quantized because the utilized scale factor as computed above is not discrete but is advantageously discrete when transmitted and used.

$$\Delta=Q^{-1}(Q(\Delta))$$

Next, as shown in **1309**, the spectral coefficient is quantized using the utilized scale factor to create a “quantized spectral coefficient” $Q(C_y, \Delta)$.

$$Q(C_f, \Delta) = \text{NINT}\left(\frac{C_f}{\Delta}\right)$$

where “NINT” is the nearest integer function. Because quantizer/rate loop **206** must transmit both the quantized spectral coefficient and the utilized scale factor, a cost, C , is calculated which is associated with how many bits it will take to transmit them both. As shown in FIG. **1311**,

$$C=\text{FOO}(Q(C_y, \Delta), Q(\Delta))$$

where FOO is a function which, depending on the specific embodiment, can be easily determined by persons having ordinary skill in the art of data communications. As shown in **1313**, the cost, C is tested to determine whether it is in a permissible range PR. When the cost is within the permissible range, $Q(C_y, \Delta)$ and $Q(\Delta)$ are transmitted to entropy coder **208**.

Advantageously, and depending on the relationship of the cost C to the permissible range PR the interpolation constant and bounds are adjusted until the utilized scale factor yields a quantized spectral coefficient which has a cost within the permissible range. Illustratively, as shown in FIG. **13** at **1313**, the interpolation bounds are manipulated to produce a binary search. Specifically,

$$\text{when } C > \text{PR}, \alpha_{high} = \alpha,$$

alternately,

$$\text{when } C < \text{PR}, \alpha_{low} = \alpha.$$

In either case, a new interpolation constant is calculated by:

$$\alpha = \frac{\alpha_{low} + \alpha_{high}}{2}$$

5

The process then continues at **1305** iteratively until the C comes within the permissible range PR.

STEREOPHONIC DECODER

The stereophonic decoder has a very simple structure as shown in FIG. **12**. Its main functions are reading the incoming bitstream (**1202**), decoding all the data (**1203**), inverse quantization and reconstruction of RIGHT and LEFT channels (**1204**). The technique is represented in FIG. **12**. Thus, the decoder is performing complementary operations to that of the encoder depicted in FIG. **7** such as operations that are complementary to quantization (**704**) and Huffman coding (**705**).

Illustrative embodiments may comprise digital signal processor (DSP) hardware, such as the AT&T DSP16 or DSP32C, and software performing the operations discussed below of the present invention. Very large scale integration (VLSI) hardware embodiments of the present invention, as well as hybrid DSP/VLSI embodiments, may also be provided. For example, an AT&T DSP16 may be employed to perform the operations of the rate loop processor depicted in FIG. **13**. The DSP could receive the spectral coefficients and energy thresholds (**1301**) and perform the calculation of blocks **1303** and **1305** as described on page **31**. Further, the DSP could calculate the utilized scale factor according to the equation given on page **32** and depicted in block **1305**. The quantization blocks **1307** and **1308** can be carried out as described on page **32**. Finally, the DSP may perform the cost calculation (**1311**) and comparison (**1313**) associated with quantization. The cost calculation is described on page **32** and illustrated further in FIG. **9**. In this way, the interpolation factor may be adjusted (**1315**) according to the analysis carried out within the DSP or similar type hardware embodiments. It is to be understood that the above-described embodiments is merely illustrative of the principles of this invention. Other arrangements may be derived by those skilled in the art without departing from the spirit and scope of the invention.

I claim:

1. A method of coding an audio signal comprising:

- (a) converting a time domain representation of the audio signal into a frequency domain representation of the audio signal, the frequency domain representation comprising a set of frequency coefficients;
- (b) calculating a masking threshold based upon the set of frequency coefficients;
- (c) using a rate loop processor in an iterative fashion to determine a set of quantization step size coefficients for use in encoding the set of frequency coefficients, said set of quantization step size coefficients determined by using the masking threshold and an absolute hearing threshold; and
- (d) coding the set of frequency coefficients based upon the set of quantization step size coefficients.

[2. The method of claim **1** wherein the set of frequency coefficients are MDCT coefficients.]

3. The method of claim **1** wherein the using the rate loop processor in the iterative fashion is discontinued when a cost, measured by the number of bits necessary to code the set of frequency coefficients, is within a predetermined range.

4. A decoder for decoding a set of frequency coefficients representing an audio signal, the decoder comprising:

25

- (a) means for receiving the set of coefficients, the set of frequency coefficients having been encoded by:
- (1) converting a time domain representation of the audio signal into a frequency domain representation of the audio signal comprising the set of frequency coefficients; 5
 - (2) calculating a masking threshold based upon the set of frequency coefficients;
 - (3) using a rate loop processor in an iterative fashion to determine a set of quantization step size coefficients

26

- needed to encode the set of frequency coefficients, said set of quantization step size coefficients determined by using the masking threshold and an absolute hearing threshold; and
- (4) coding the set of frequency coefficients based upon the set of quantization step size coefficients; and
- (b) means for converting the set of coefficients to a time domain signal.

* * * * *