



US00RE38945E

(19) **United States**
(12) **Reissued Patent**
Fried et al.

(10) **Patent Number: US RE38,945 E**
(45) **Date of Reissued Patent: Jan. 24, 2006**

(54) **DENTAL IMPLANTS AND METHODS FOR EXTENDING SERVICE LIFE**

(75) Inventors: **Paula S. Fried**, 207-20 Jordan Dr., Bayside, NY (US) 11360; **Leonard Cooper**, Pelham Manor, NY (US)

(73) Assignee: **Paula S. Fried**, Hayside, NY (US)

4,846,683 A 7/1989 Lazzara et al.
4,856,994 A 8/1989 Lazzara et al.
4,886,456 A 12/1989 Ross
4,955,811 A 9/1990 Lazzara et al.
5,013,242 A 5/1991 Prezmecky
5,015,186 A 5/1991 Detsch
5,052,931 A 10/1991 Kirsch
5,125,840 A 6/1992 Dürr et al.
5,195,892 A 3/1993 Gersberg

(21) Appl. No.: **09/667,827**

(22) Filed: **Sep. 22, 2000**

(Continued)

FOREIGN PATENT DOCUMENTS

FR 2635455 2/1999
JP 06-178784 6/1994

Related U.S. Patent Documents

Reissue of:

(64) Patent No.: **5,810,590**
Issued: **Sep. 22, 1998**
Appl. No.: **08/753,887**
Filed: **Dec. 2, 1996**

U.S. Applications:

(63) Continuation-in-part of application No. 08/380,850, filed on Jan. 30, 1995, now Pat. No. 5,580,246.

(51) **Int. Cl.**
A61C 8/00 (2006.01)

(52) **U.S. Cl.** **433/172; 433/173**

(58) **Field of Classification Search** **433/173, 433/174, 175, 176, 172, 75**

See application file for complete search history.

(56) **References Cited**

U.S. PATENT DOCUMENTS

2,857,670 A * 4/1958 Kiernan, Jr. 433/75
3,672,058 A * 6/1972 Nikoghossian
4,011,602 A 3/1977 Rybicki et al.
4,179,810 A 12/1979 Kirsch
4,416,629 A 11/1983 Mozsary et al.
4,575,340 A 3/1986 Lustig
4,713,003 A 12/1987 Symington et al.
4,758,161 A 7/1988 Niznick
4,762,492 A 8/1988 Nagai

OTHER PUBLICATIONS

Branemark System Introduces TiUnite™ a Unique Oxidized Titanium Surface, Nobel Biocare, Inc., Product Catalog (2000).

Primary Stability is Essential for a Good Life, Nobel Biocare, Inc., Product Catalog (1999).

Univeral Fixture Mk III Featuring Stargrip™, Nobel Biocare, Inc., Product Catalog (1999).

Branemark System Streamline Simplicity Defined, Nobel Biocare, Inc., Product Catalog (2000).

Branemark System US Product Catalog 6th Edition, Nobel Biocare, Inc., Product Catalog (Oct. 2000).

Small Diameter Implants Solutions for Restricted Spaces, 3i, Inc., Product Catalog (1997).

Primary Examiner—Cary E. O'Connor

(74) *Attorney, Agent, or Firm*—Nixon Peabody LLP

(57) **ABSTRACT**

An implant has a proximal protrusion that is distinctly non-round even in a worn state, e.g. square in cross section, and may include radial slots for use in threading the implant into the jaw bone. No forces need be applied directly to the protrusion's external surfaces when inserting the slotted implant for subsequent osseointegration.

22 Claims, 5 Drawing Sheets

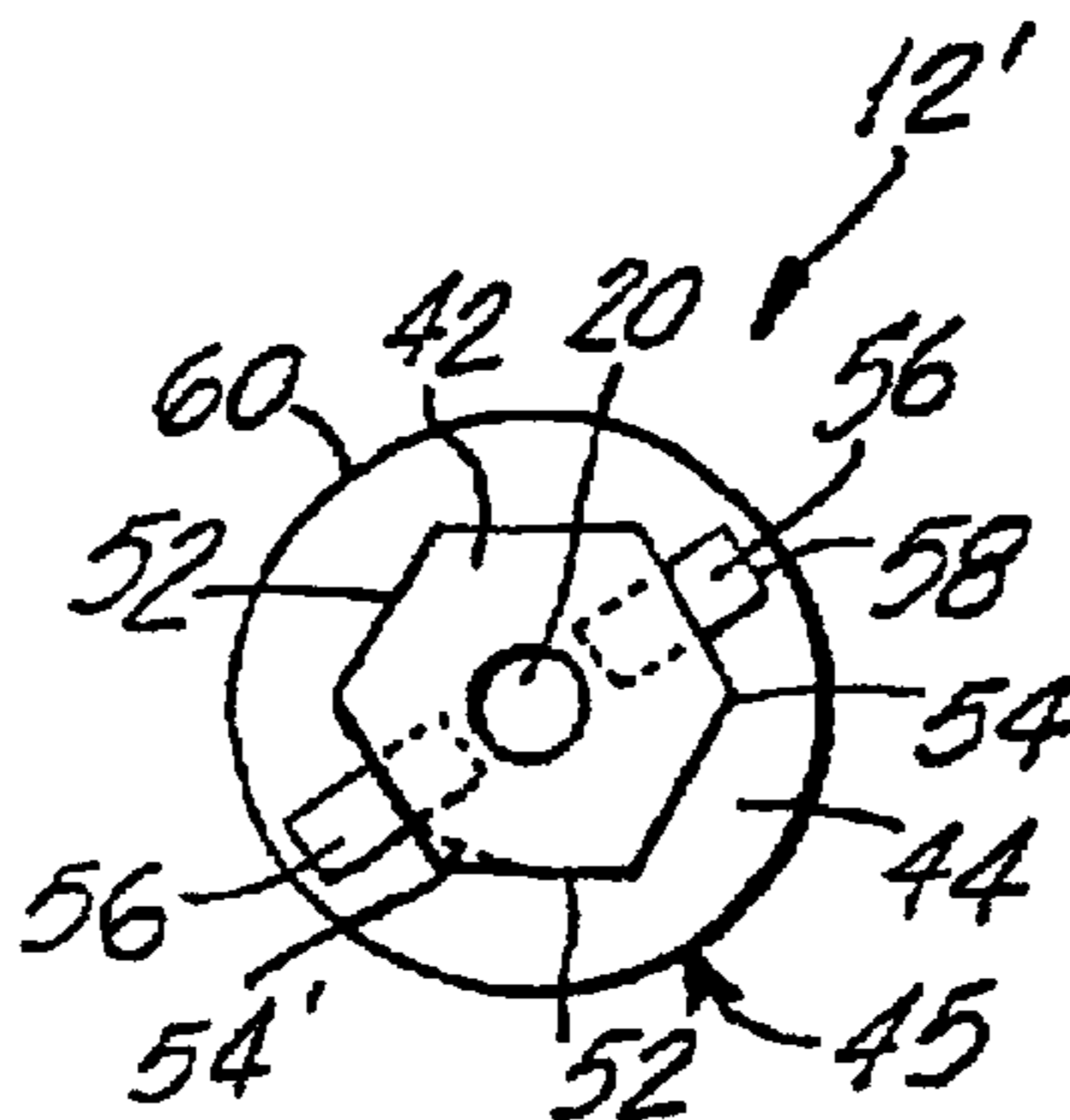

US RE38,945 E

Page 2

U.S. PATENT DOCUMENTS

5,205,746 A	4/1993	Chanavaz		5,542,847 A	8/1996	Margulies
5,316,476 A	5/1994	Krauser		4,960,381 A	4/1998	Niznick
5,338,197 A	8/1994	Kwan	433/174	5,829,977 A	11/1998	Rogers et al.
5,362,237 A	11/1994	Chalifoux		5,938,443 A	8/1999	Lazzara et al.
5,368,483 A	11/1994	Sutter et al.		5,964,591 A	10/1999	Beaty et al.
5,449,291 A	9/1995	Lueschen et al.		5,989,026 A	11/1999	Rogers et al.
5,492,471 A	* 2/1996	Singer	433/172	6,129,548 A	10/2000	Lazzara et al.
5,316,476 A	6/1996	Krauser		6,135,773 A	10/2000	Lazzara

* cited by examiner

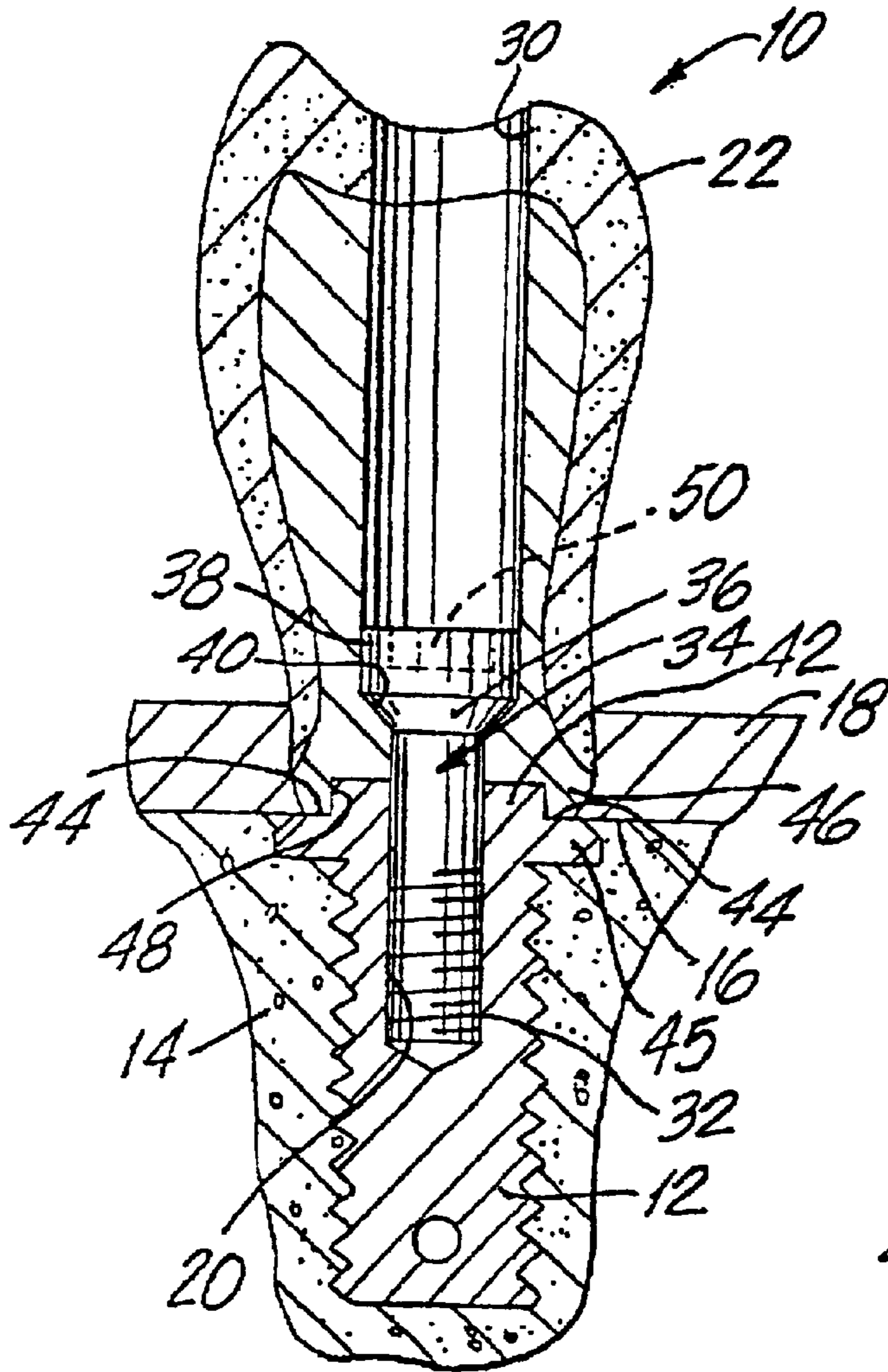

PRIOR ART
FIG. 1

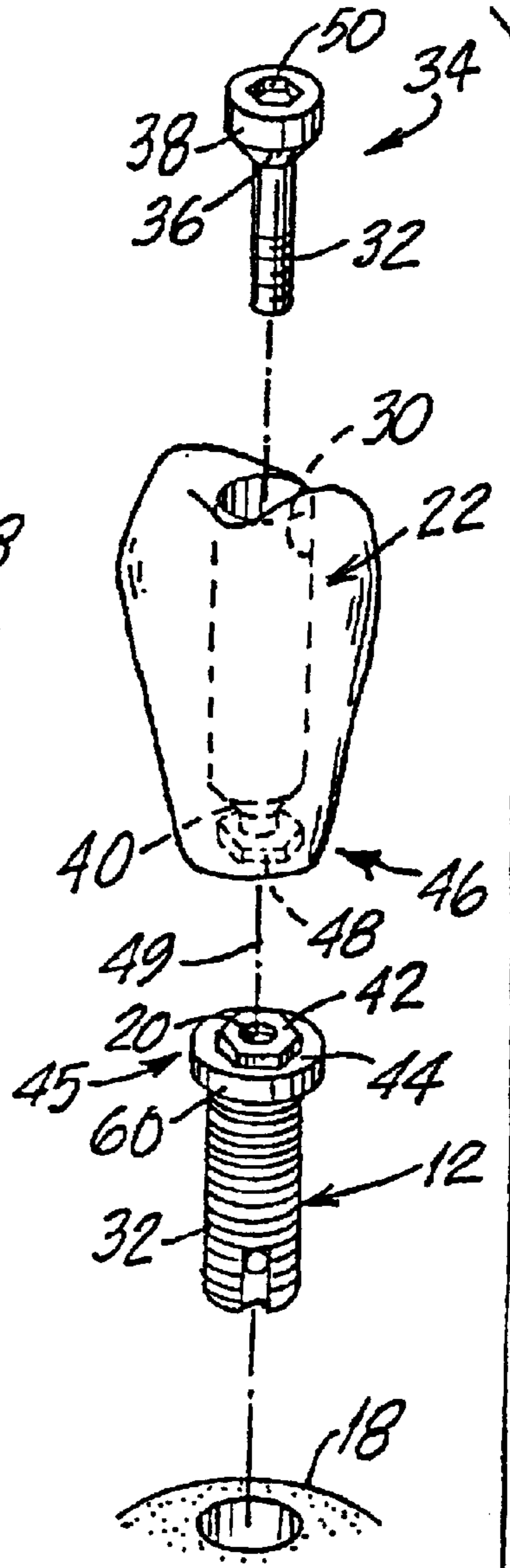

PRIOR ART
FIG. 2

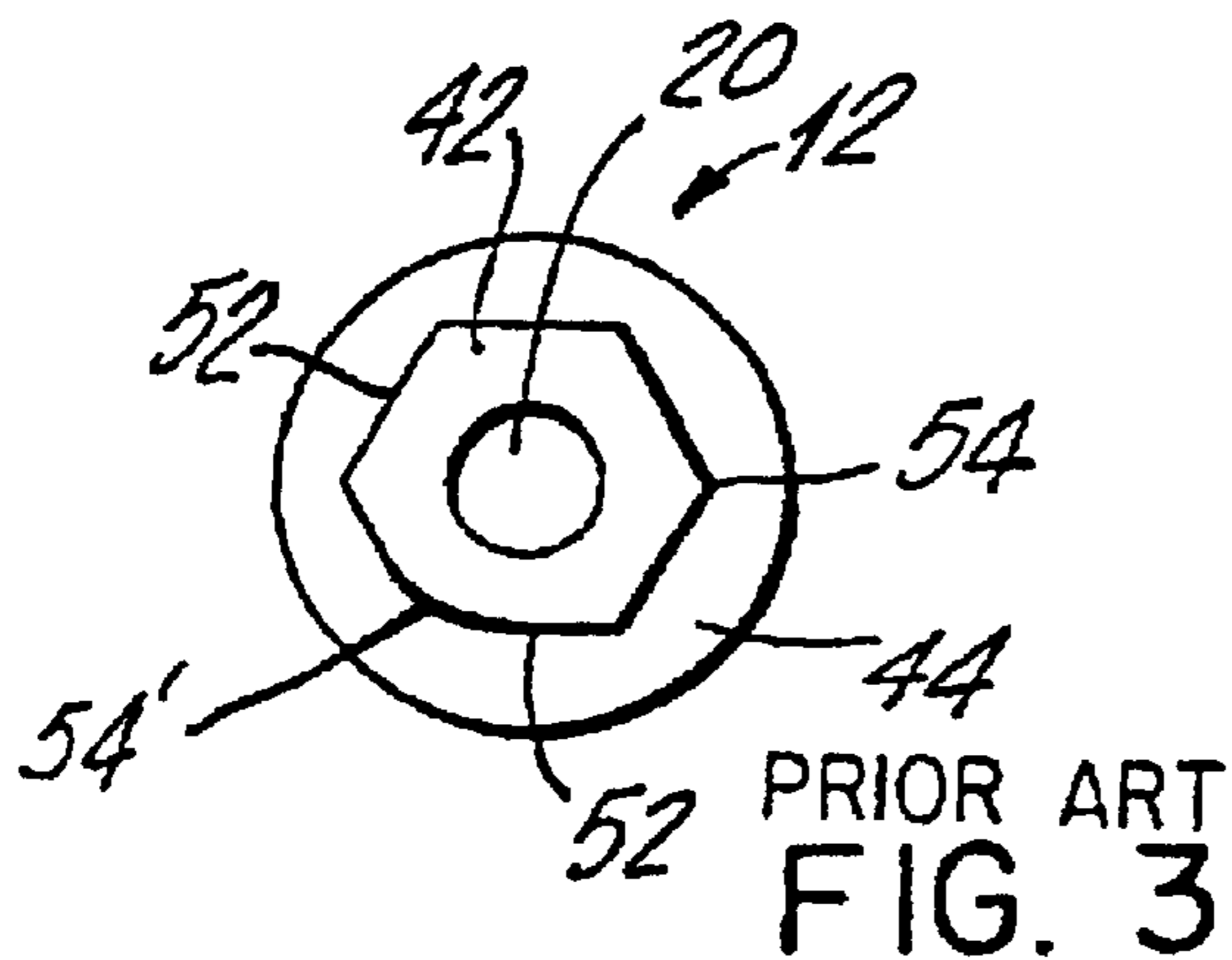

PRIOR ART
FIG. 3

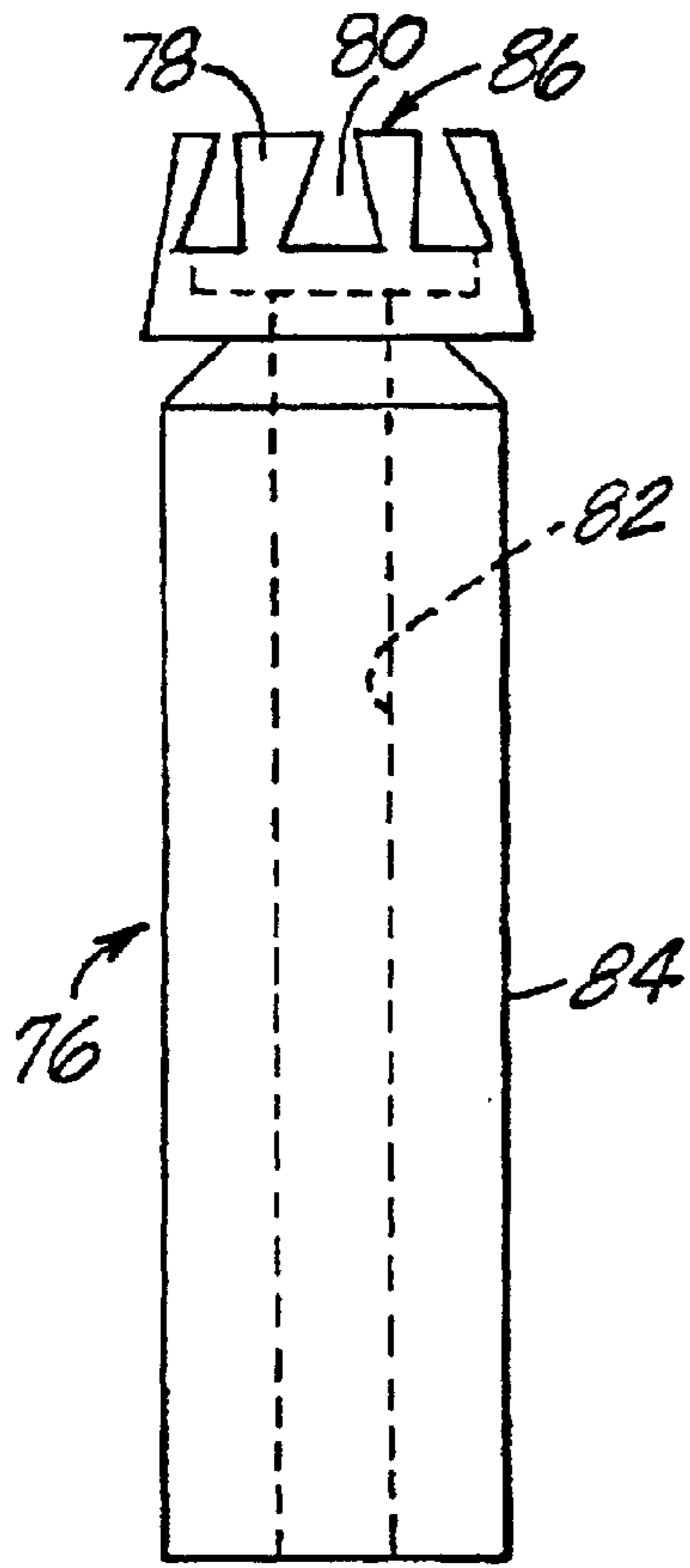
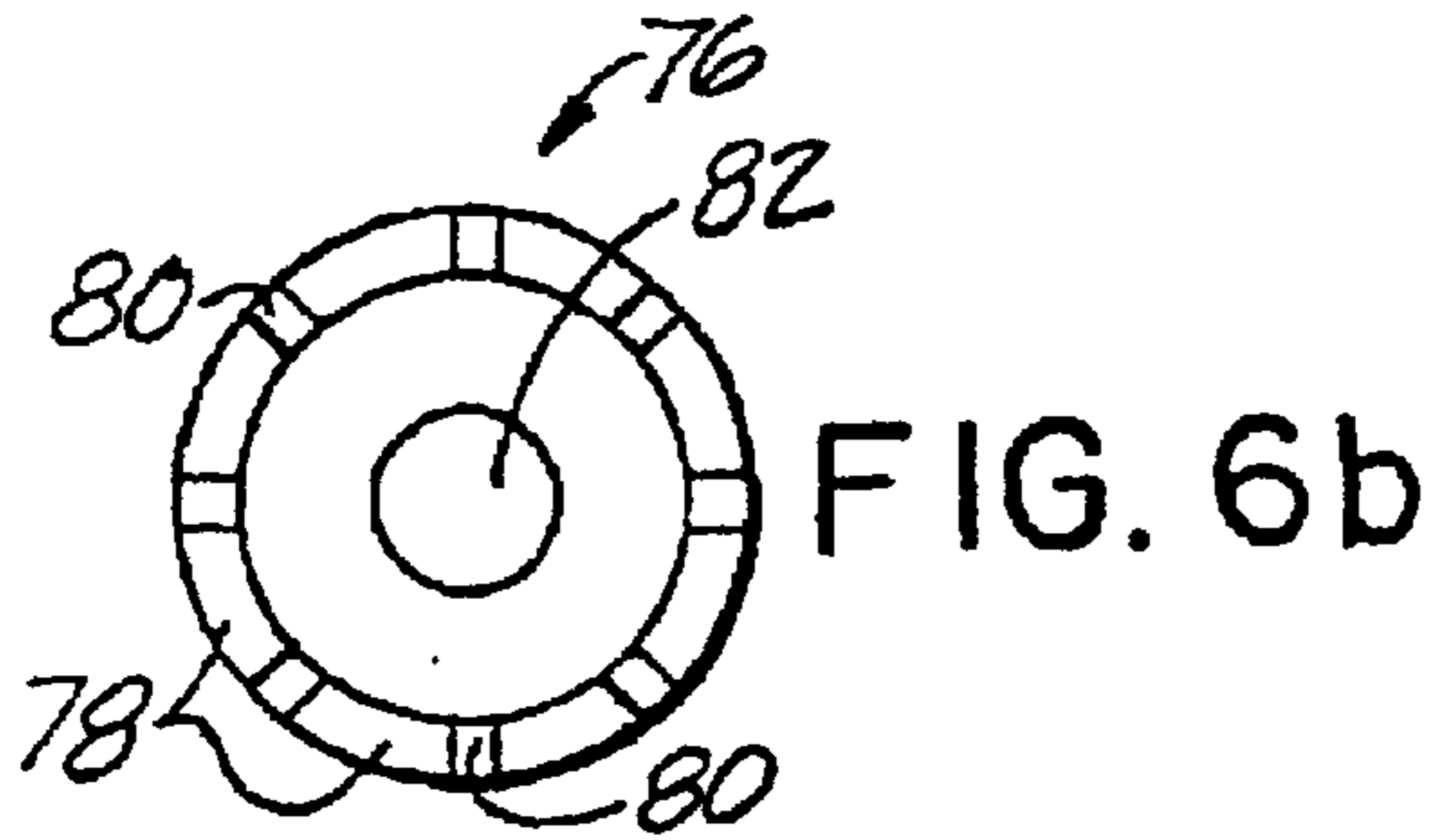

FIG. 6a

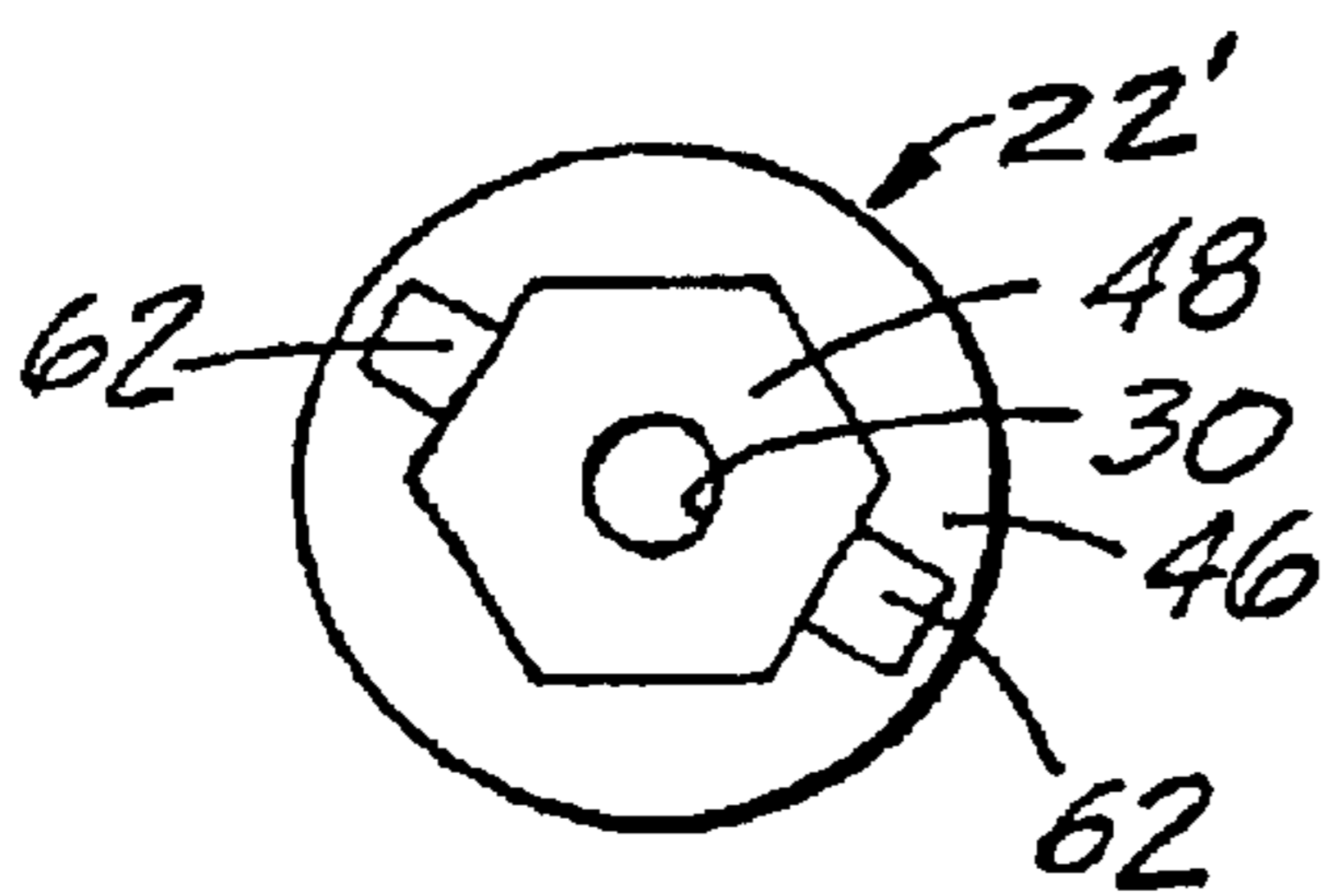

FIG. 4b

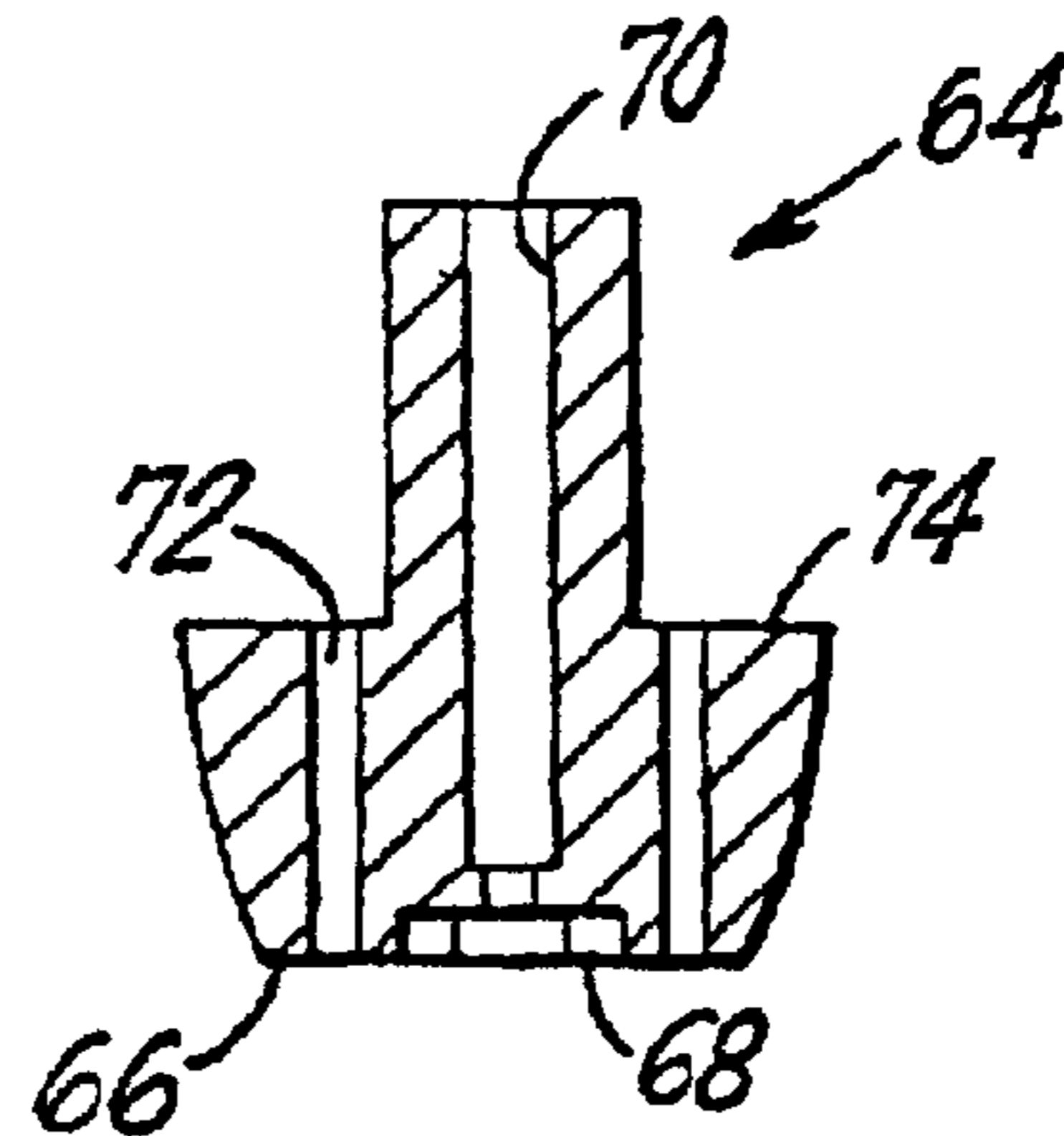

FIG. 5a

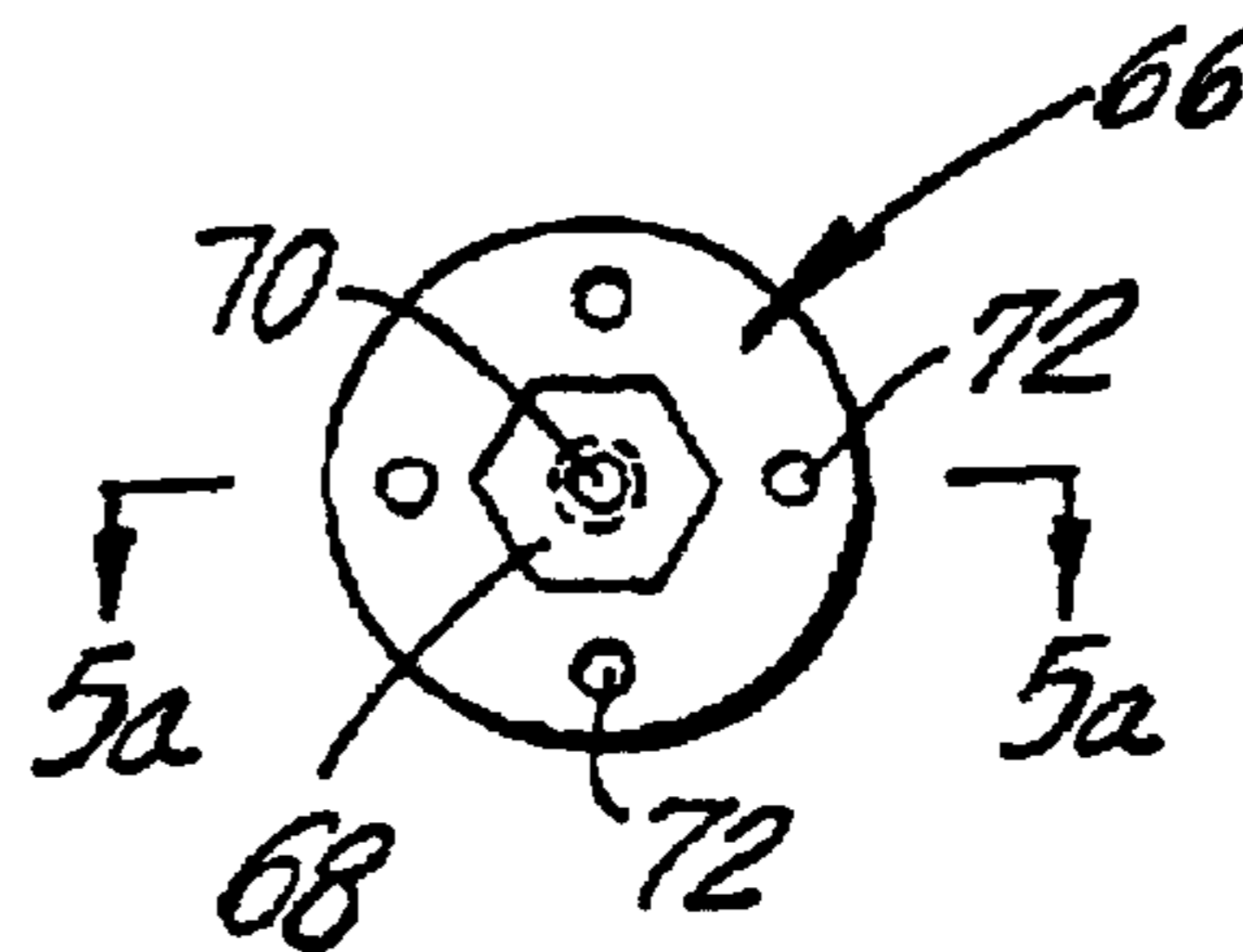

FIG. 5b

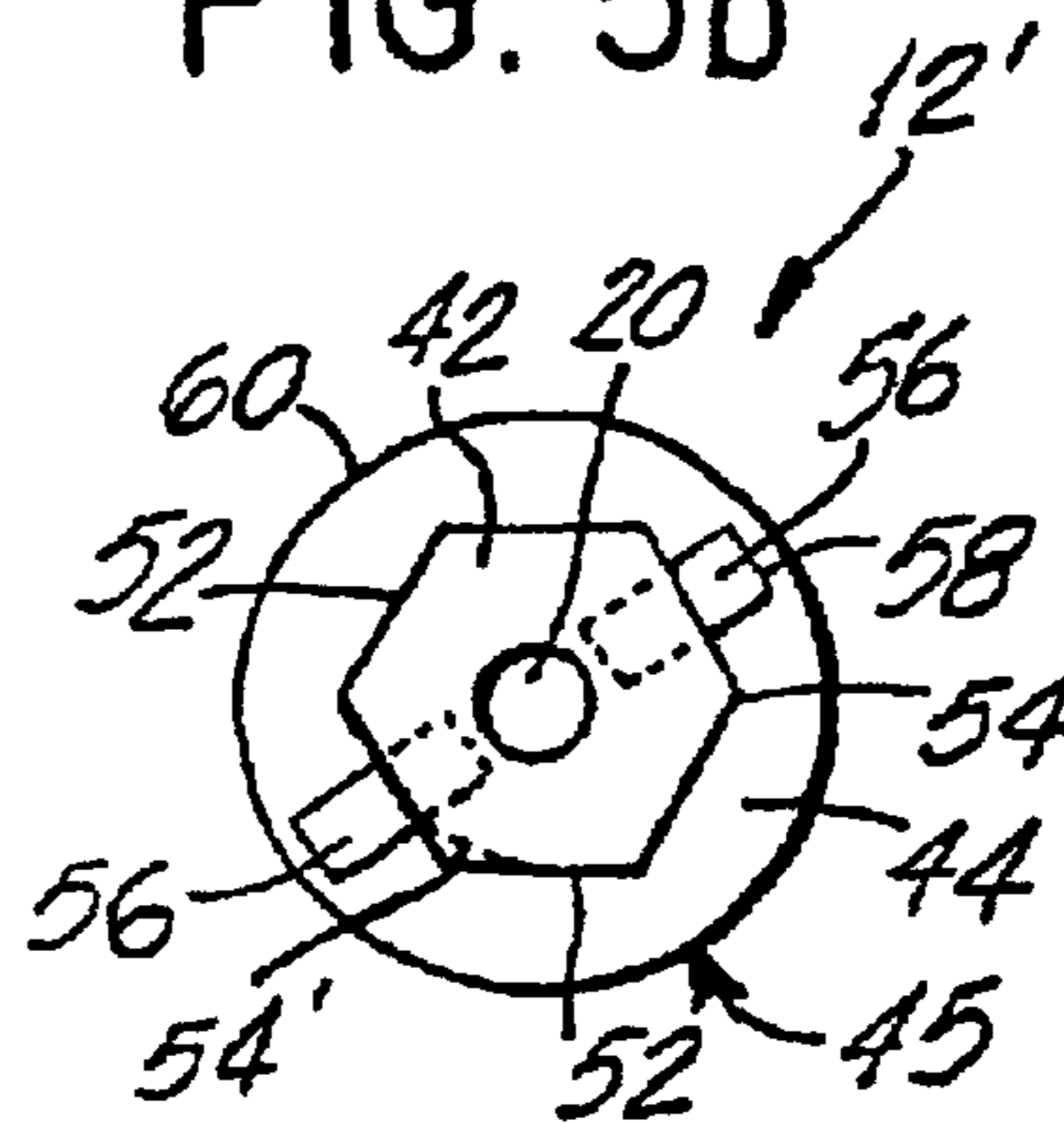

FIG. 4a

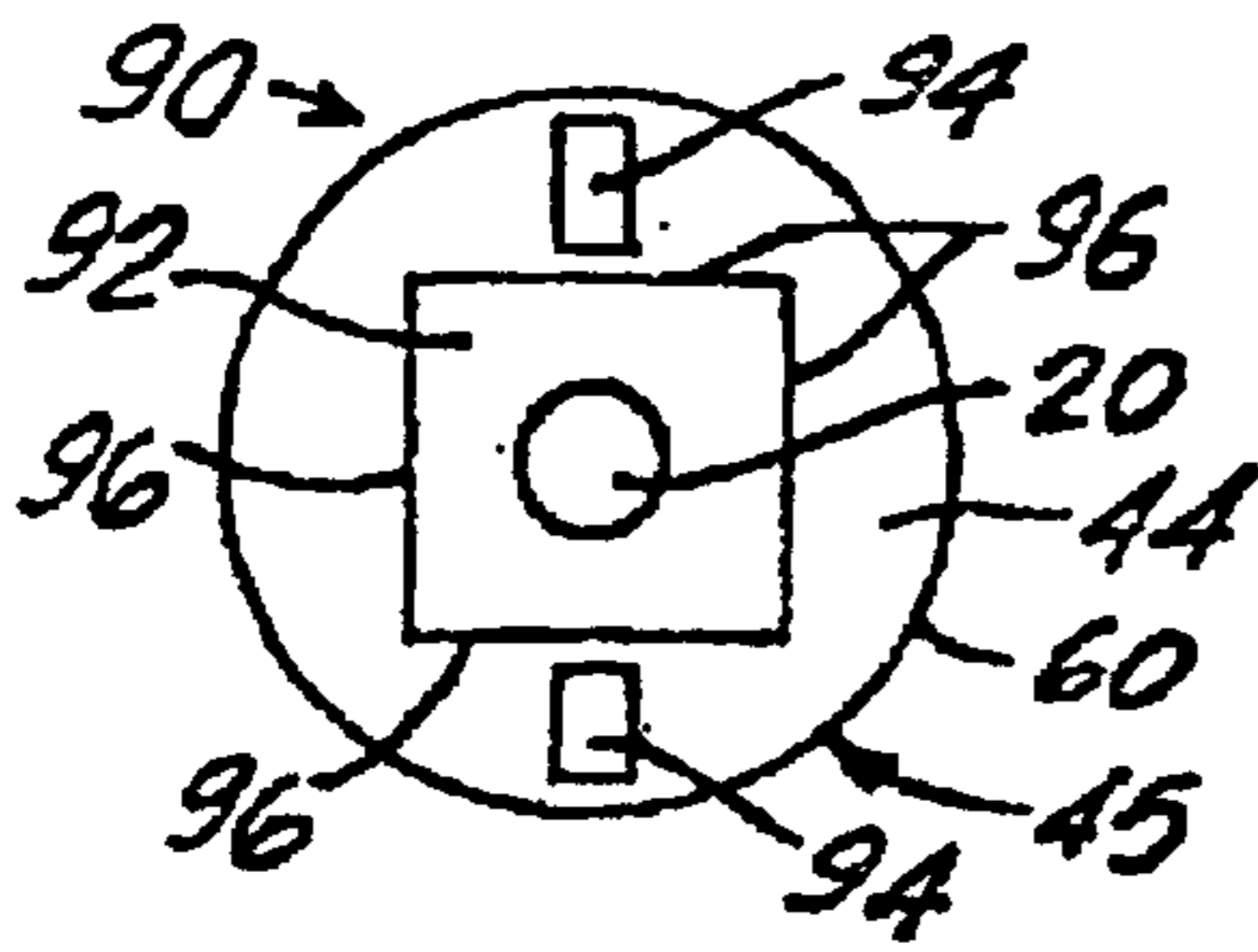

FIG. 9

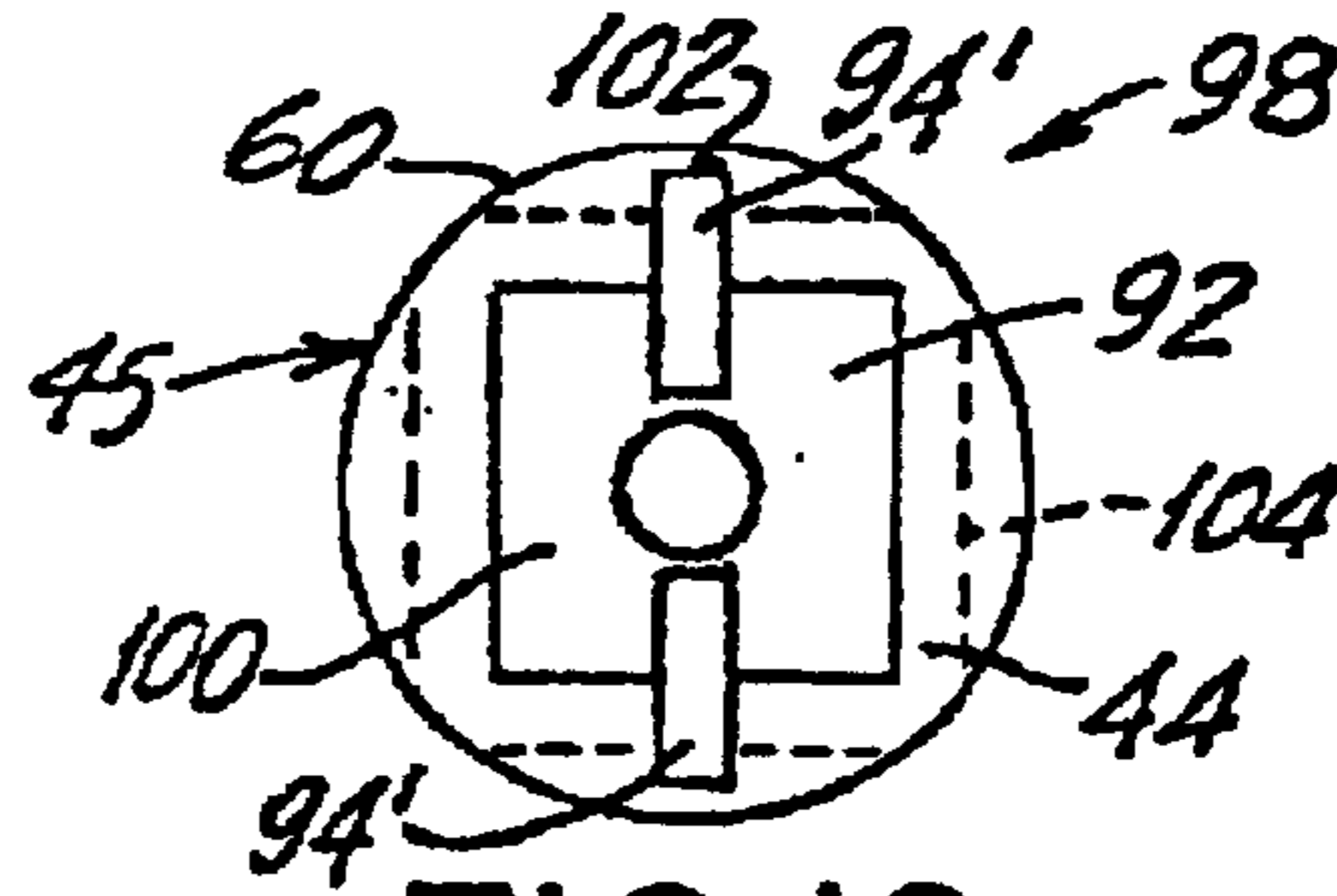

FIG. 10a

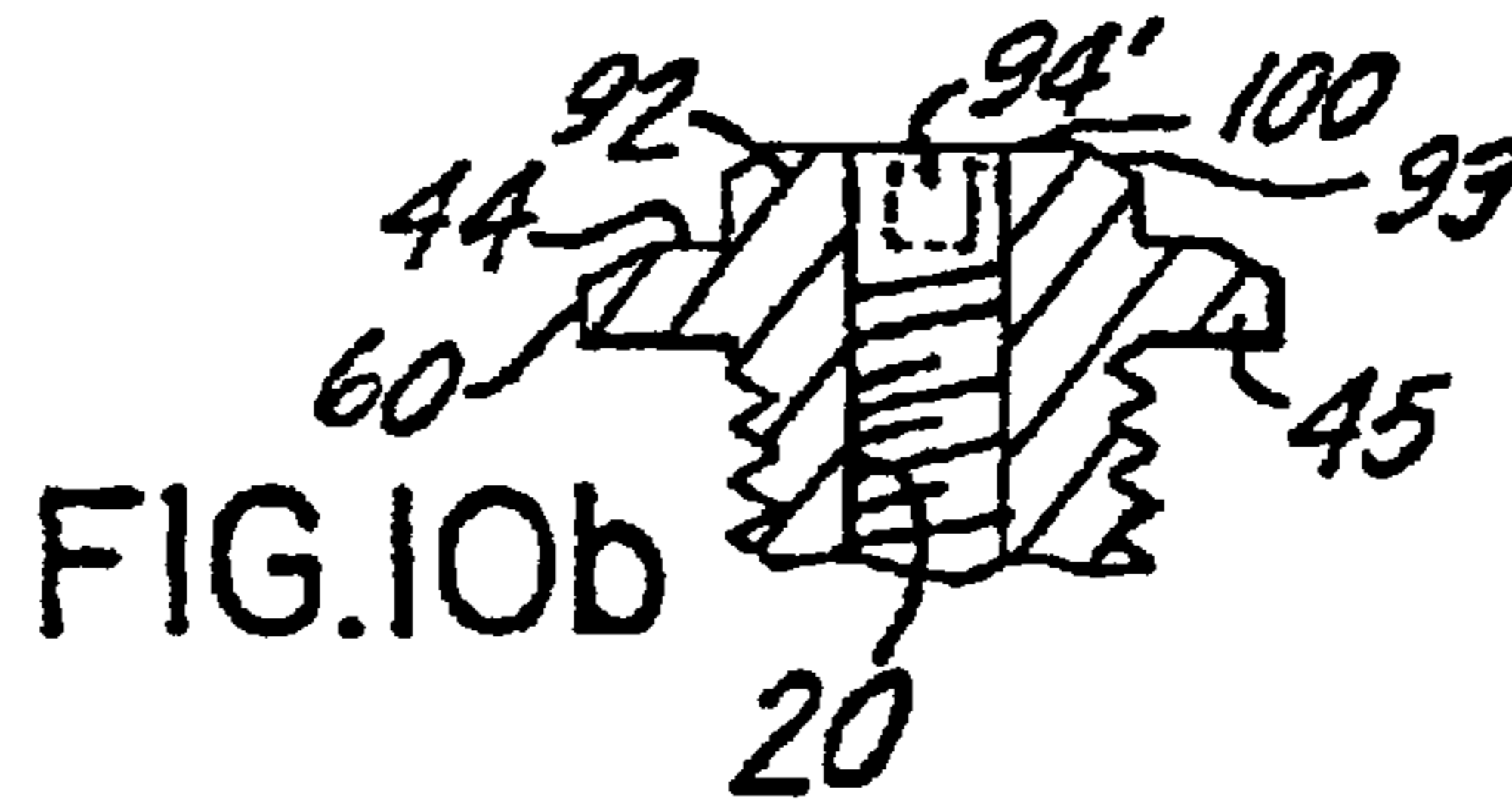

FIG. 10b

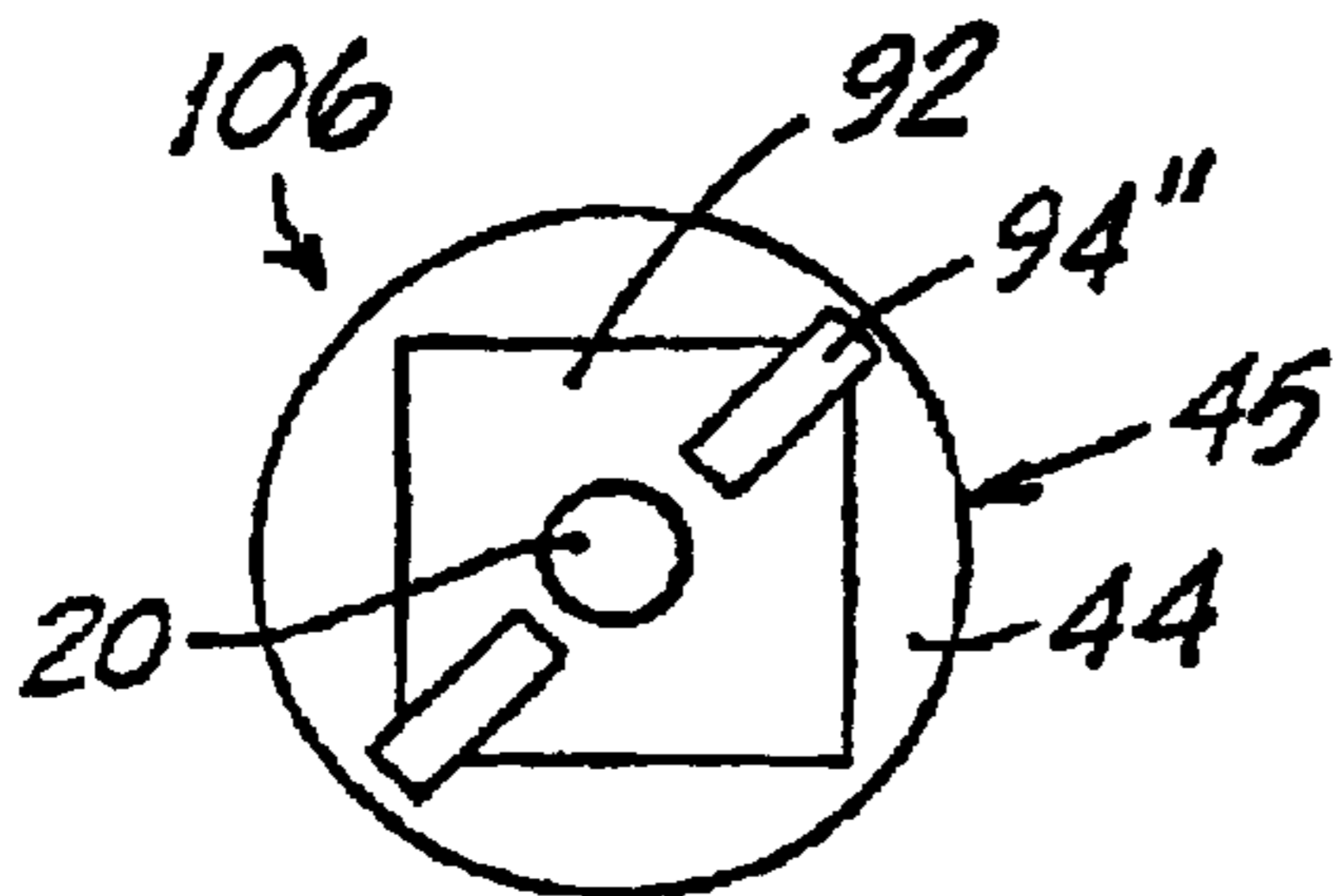

FIG. 11

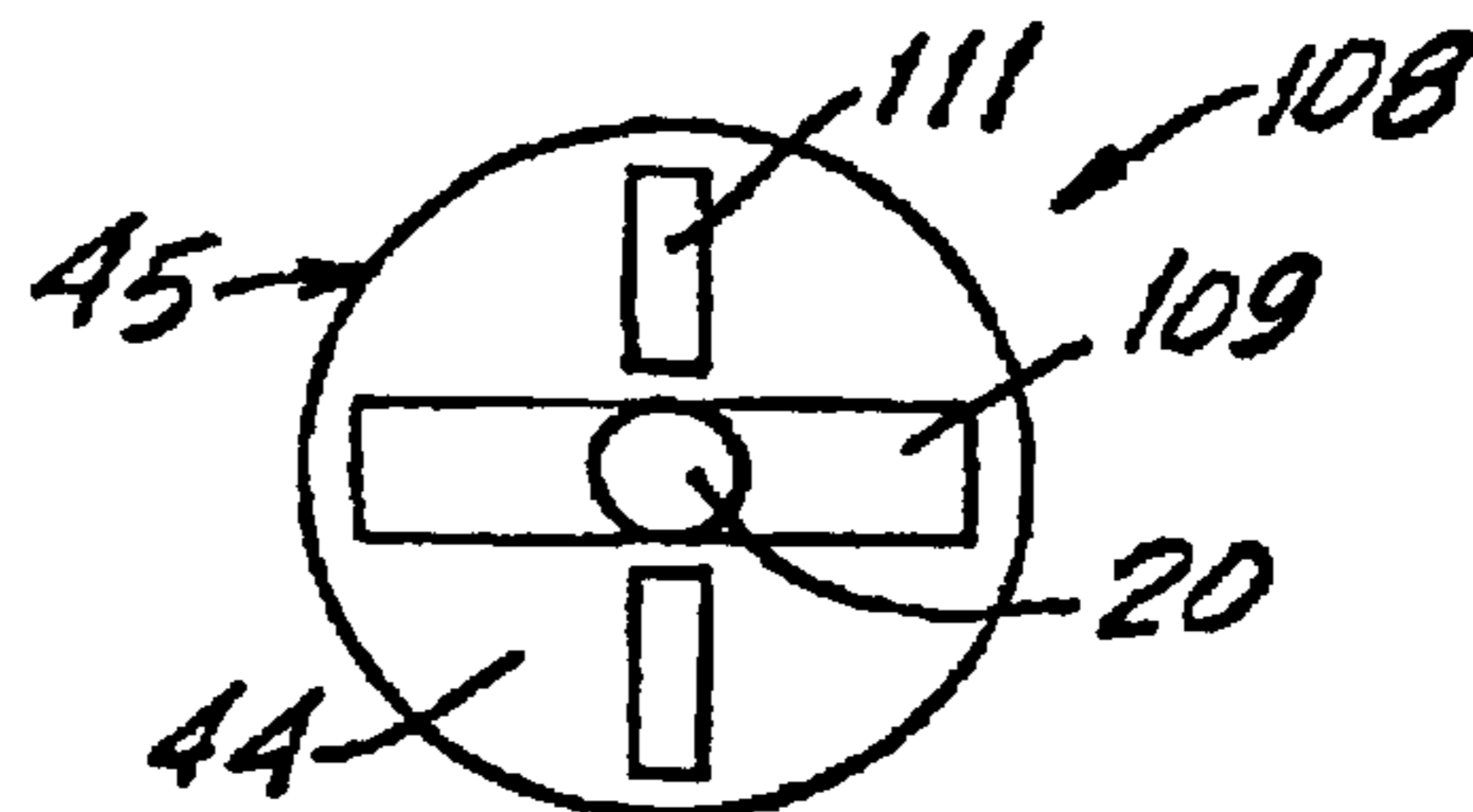

FIG. 12

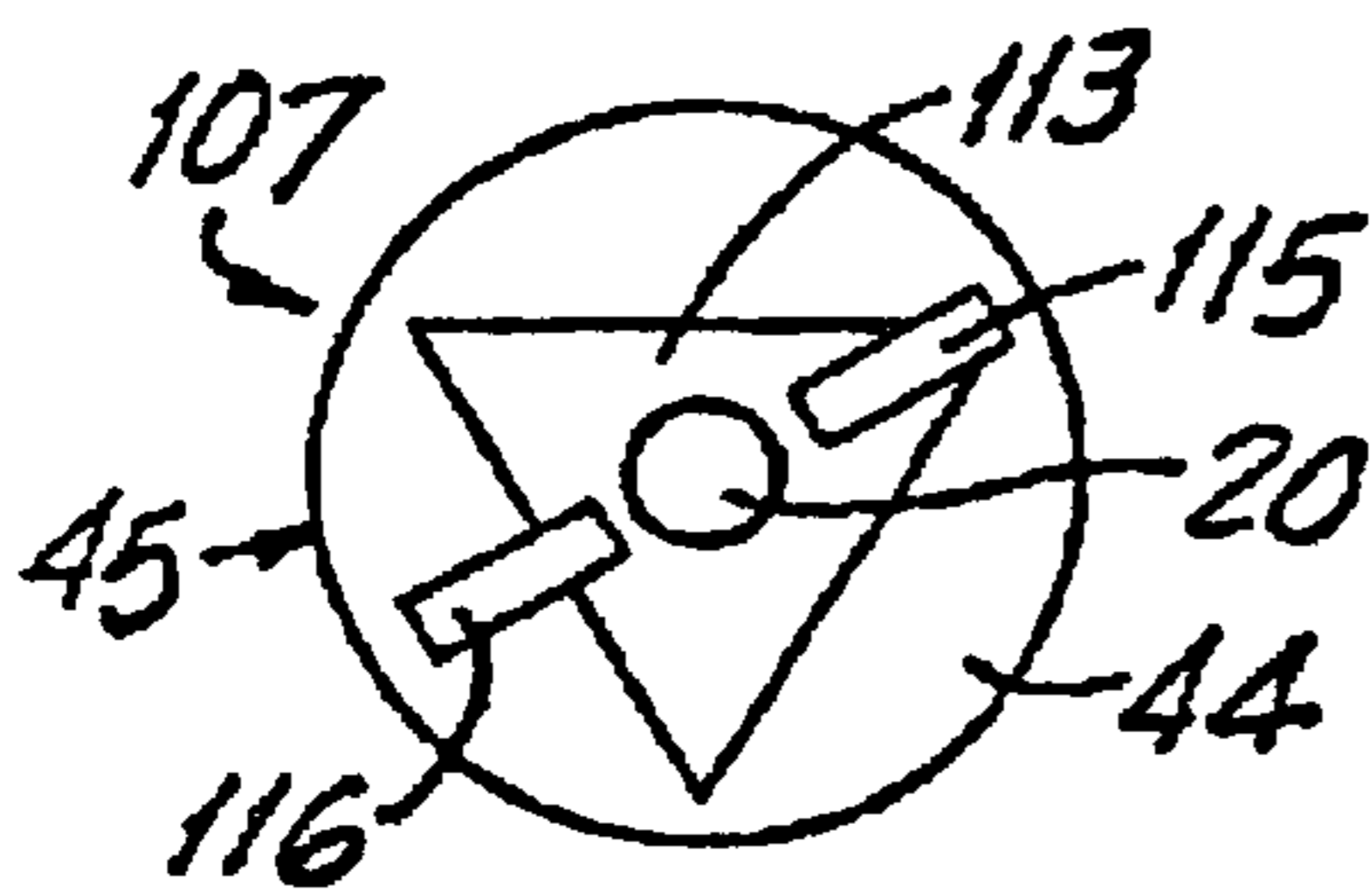

FIG. 13

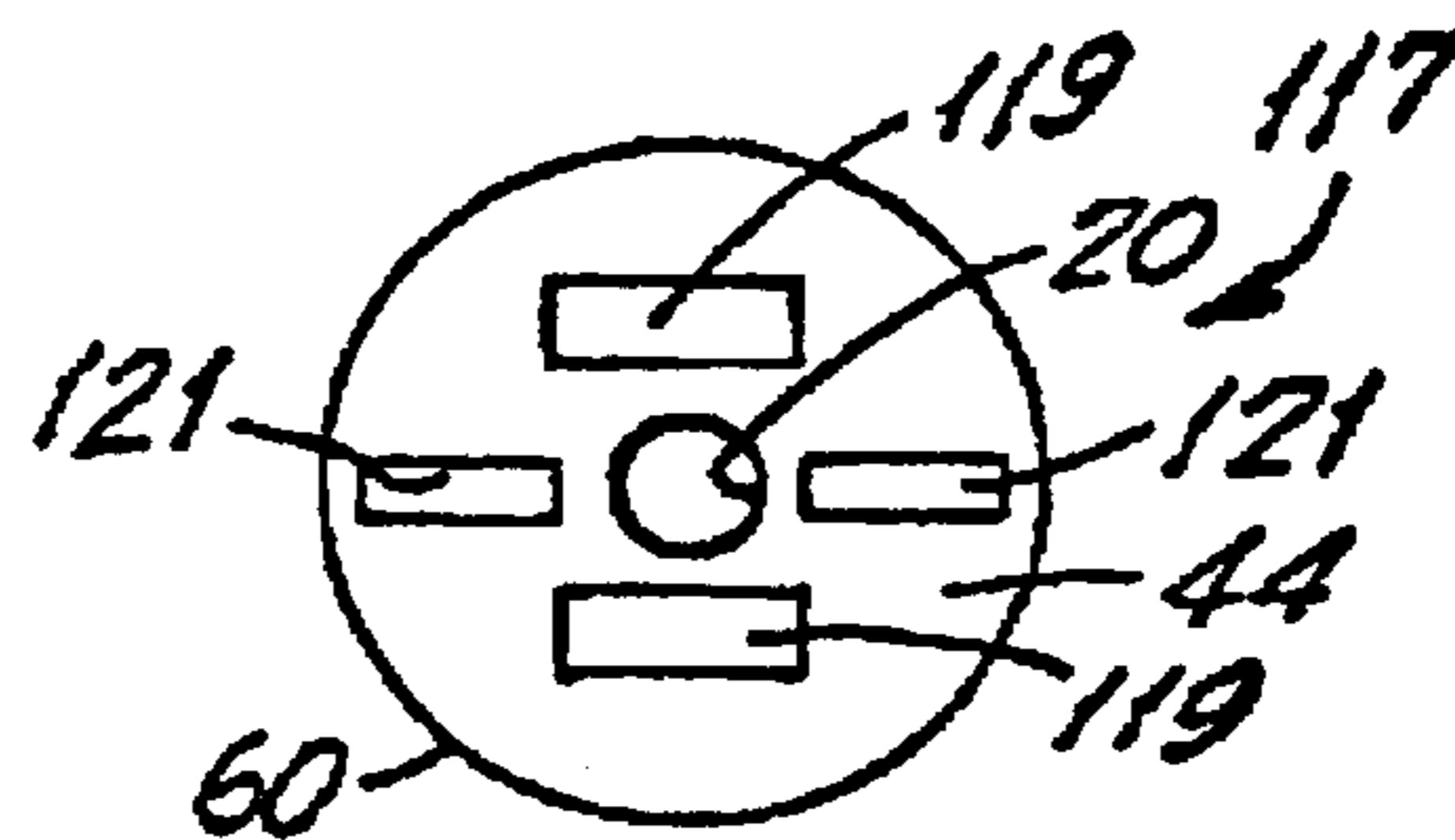

FIG. 14

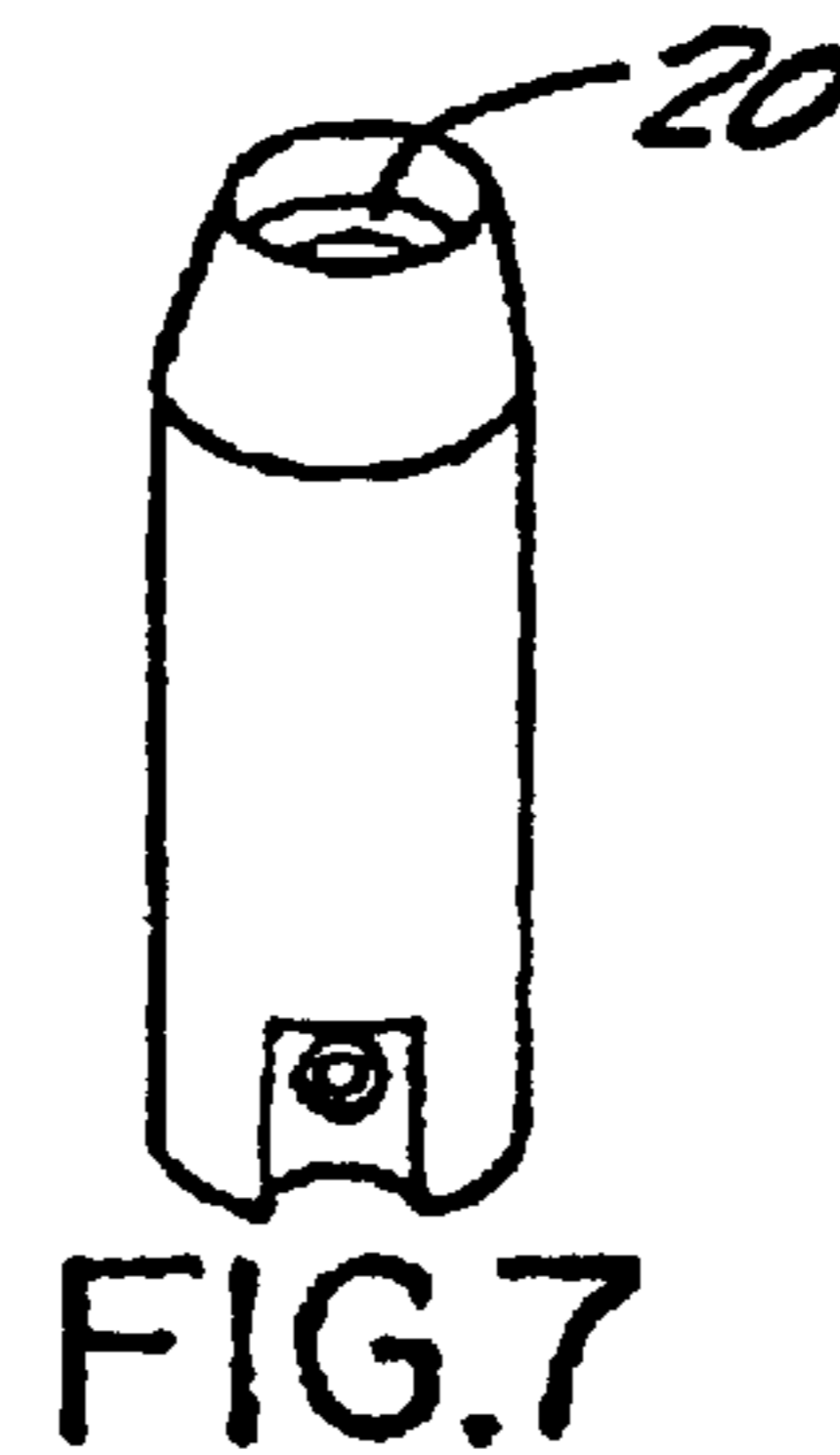
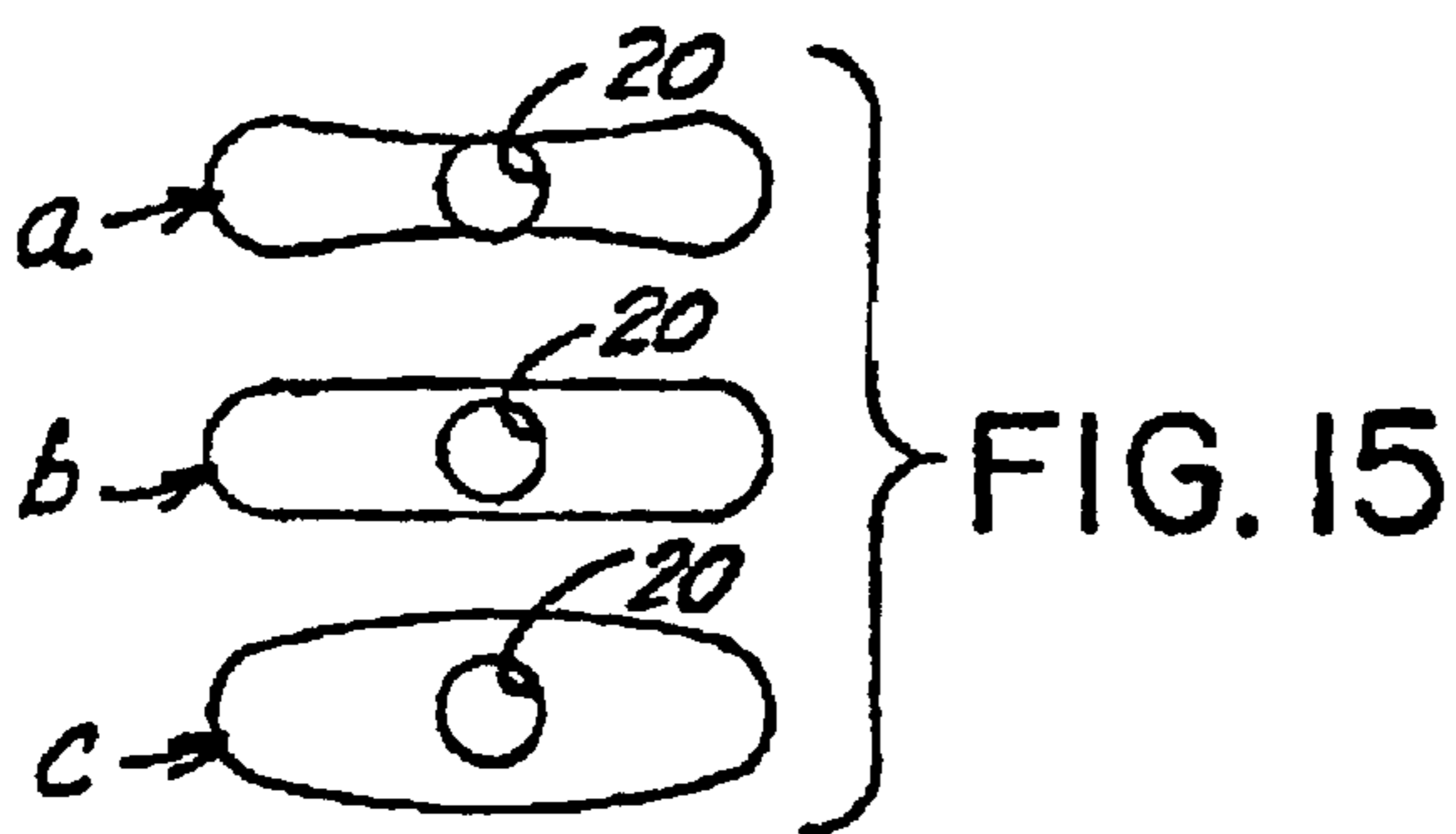

FIG. 7

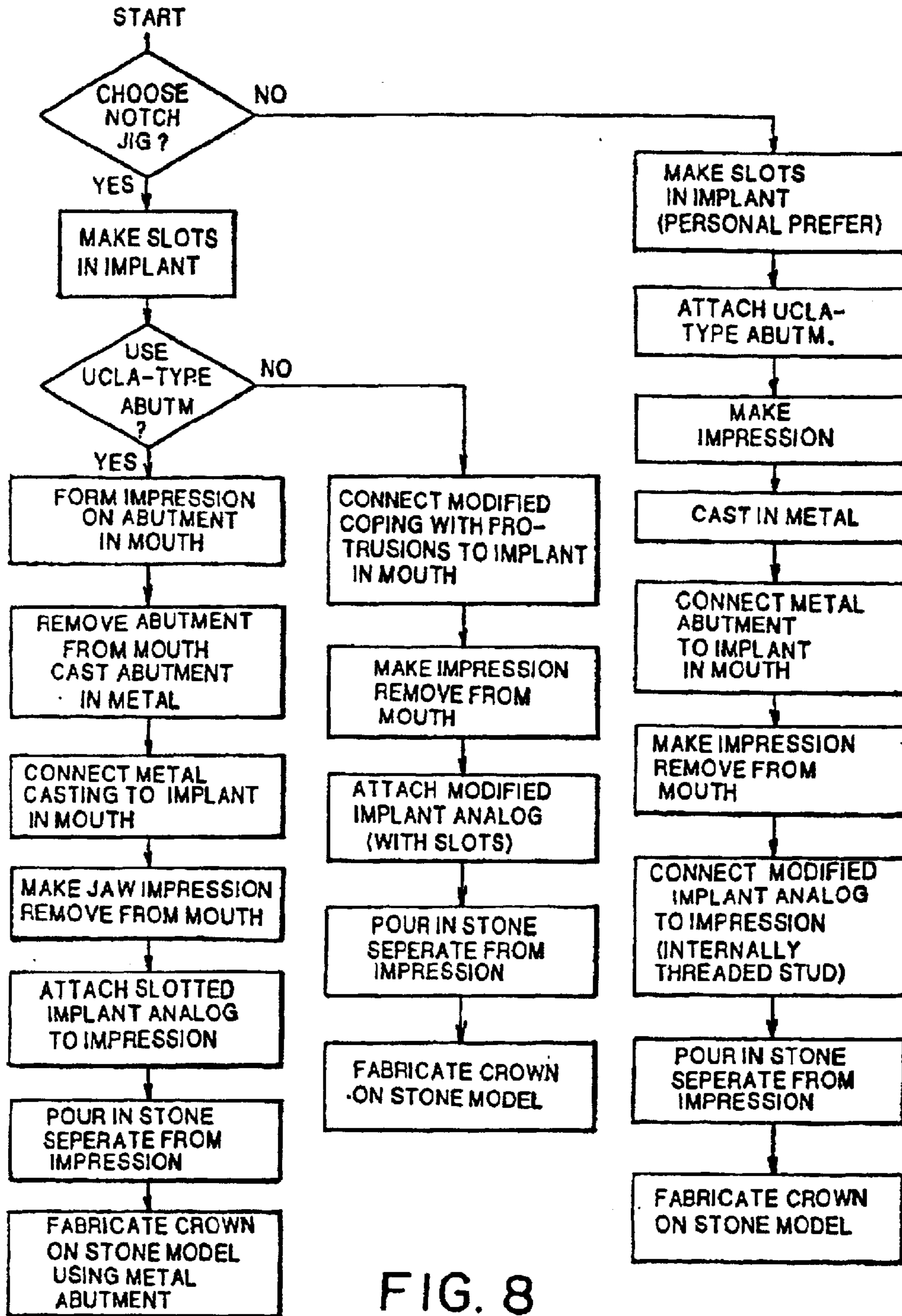

FIG. 8

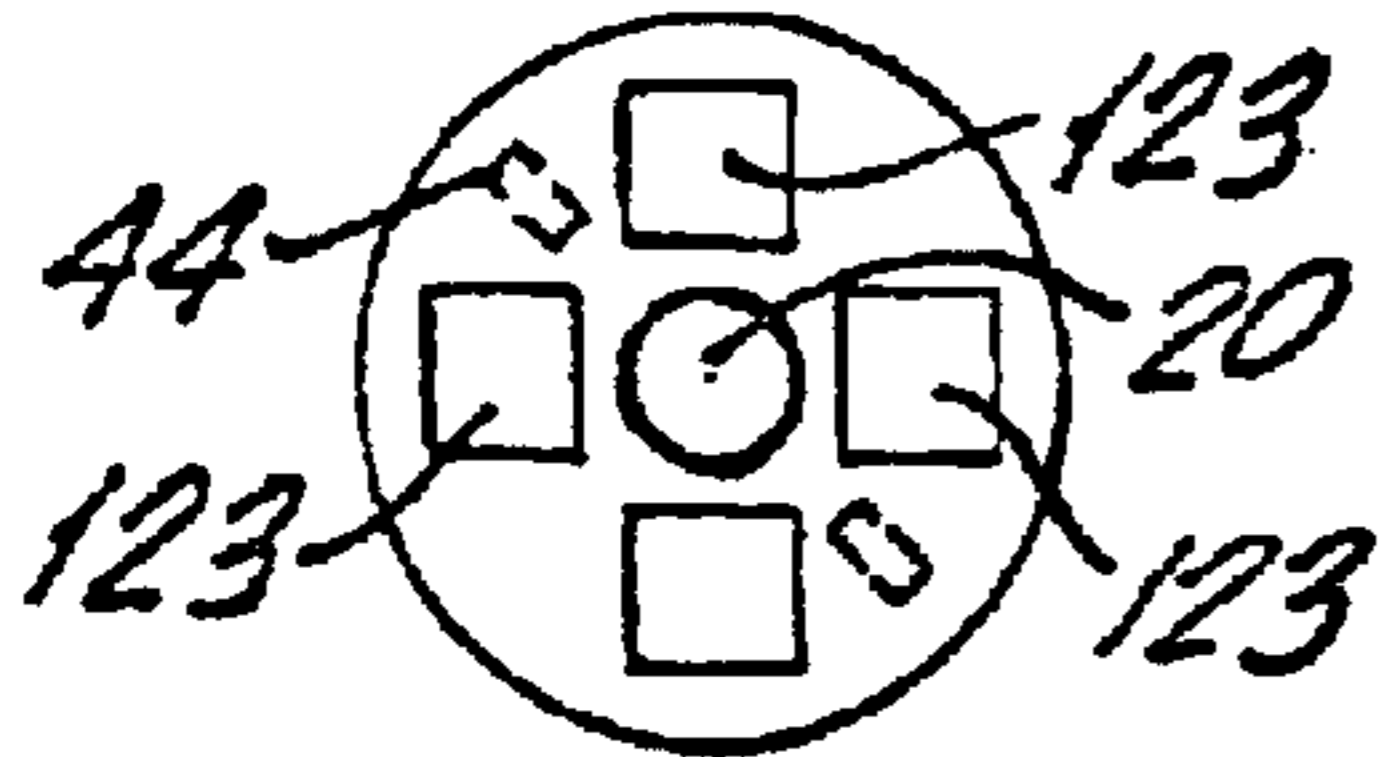

FIG. 16

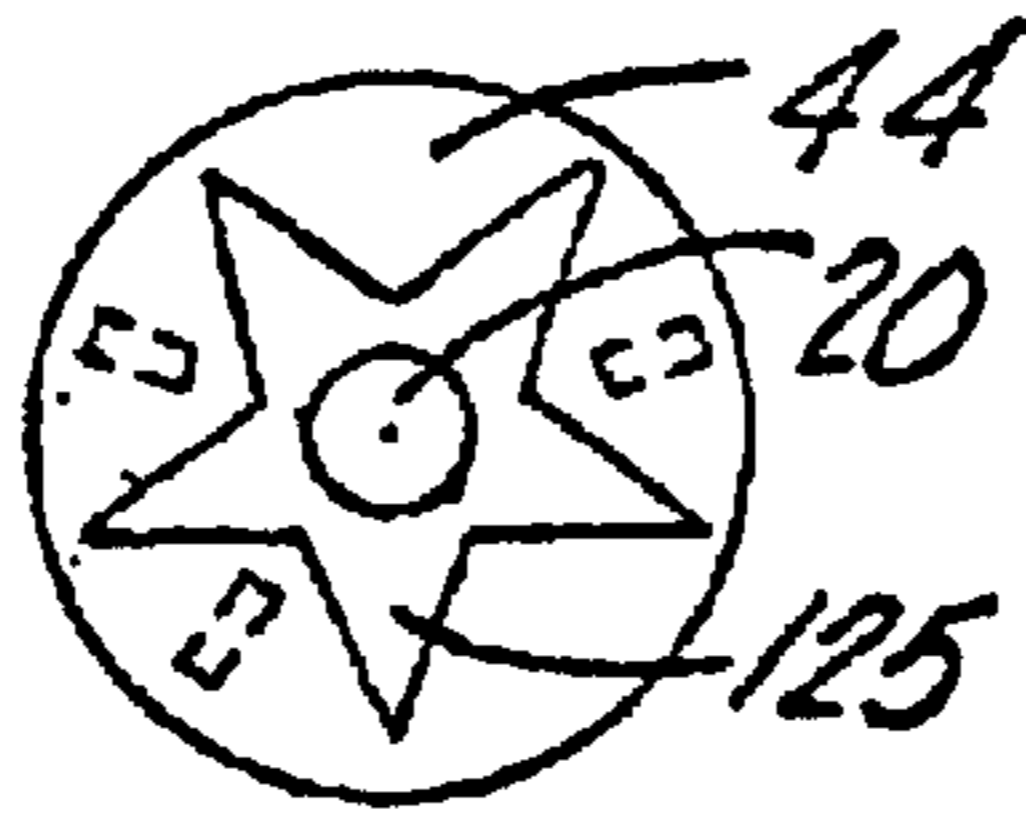

FIG. 17

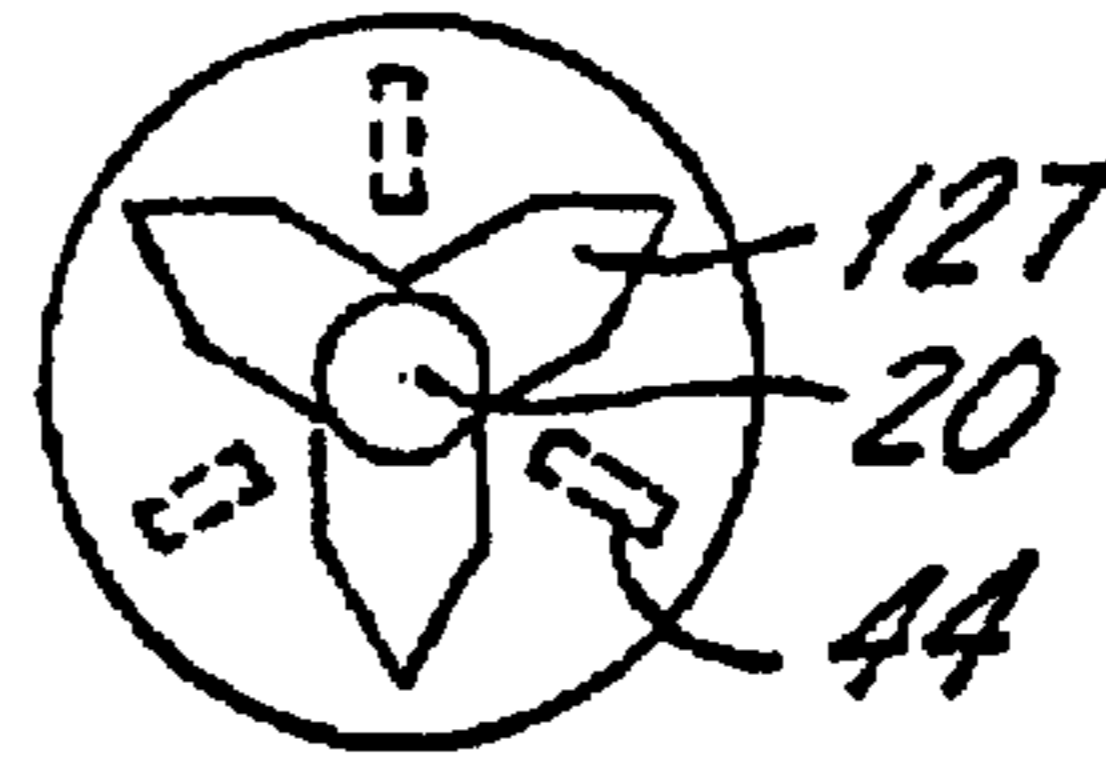

FIG. 18

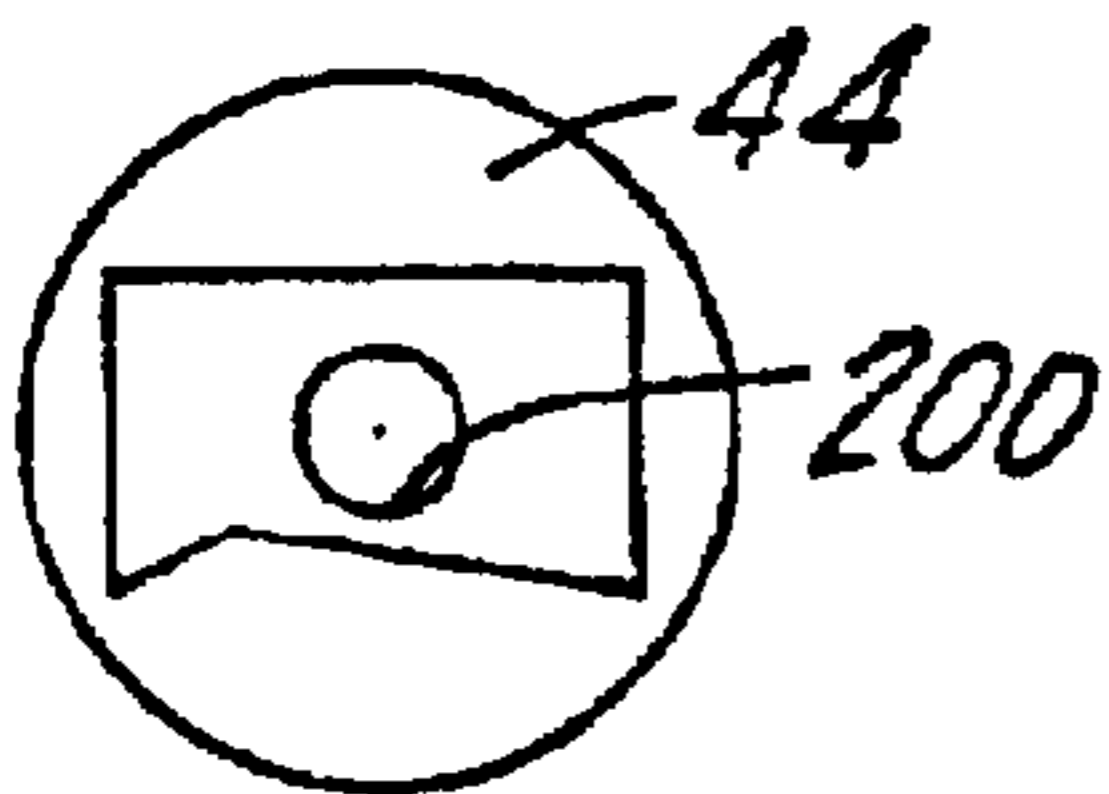

FIG. 19a

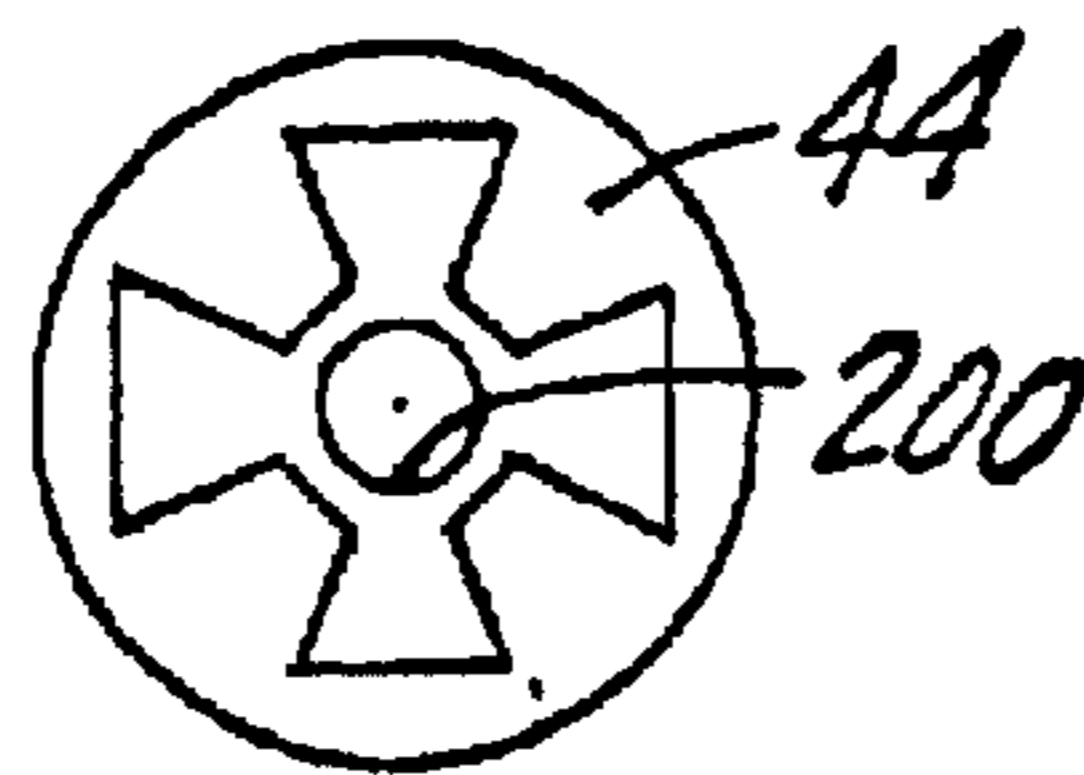

FIG. 19b

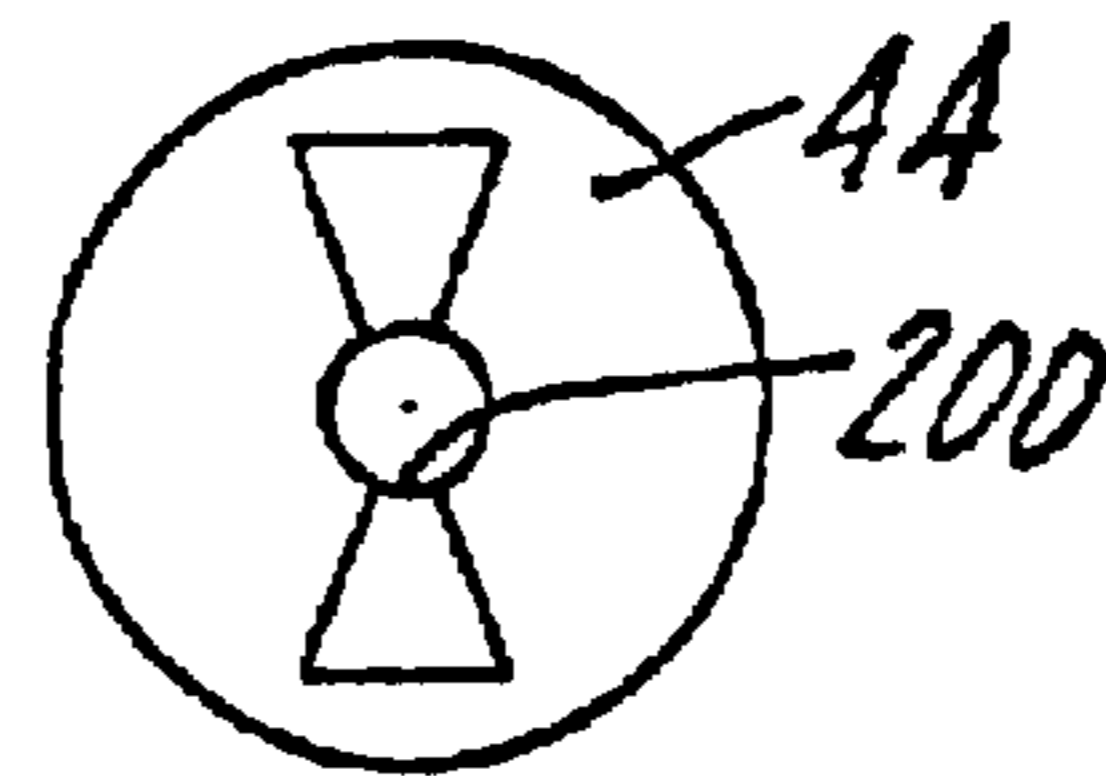

FIG. 19c

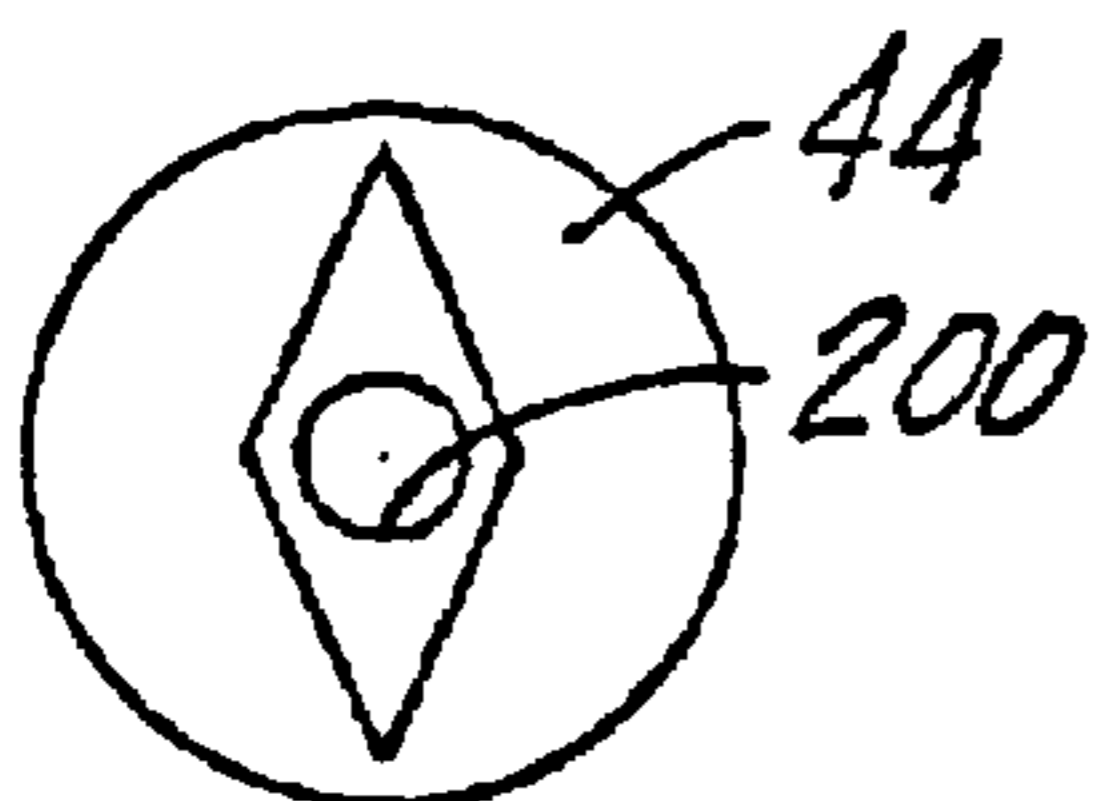

FIG. 19d

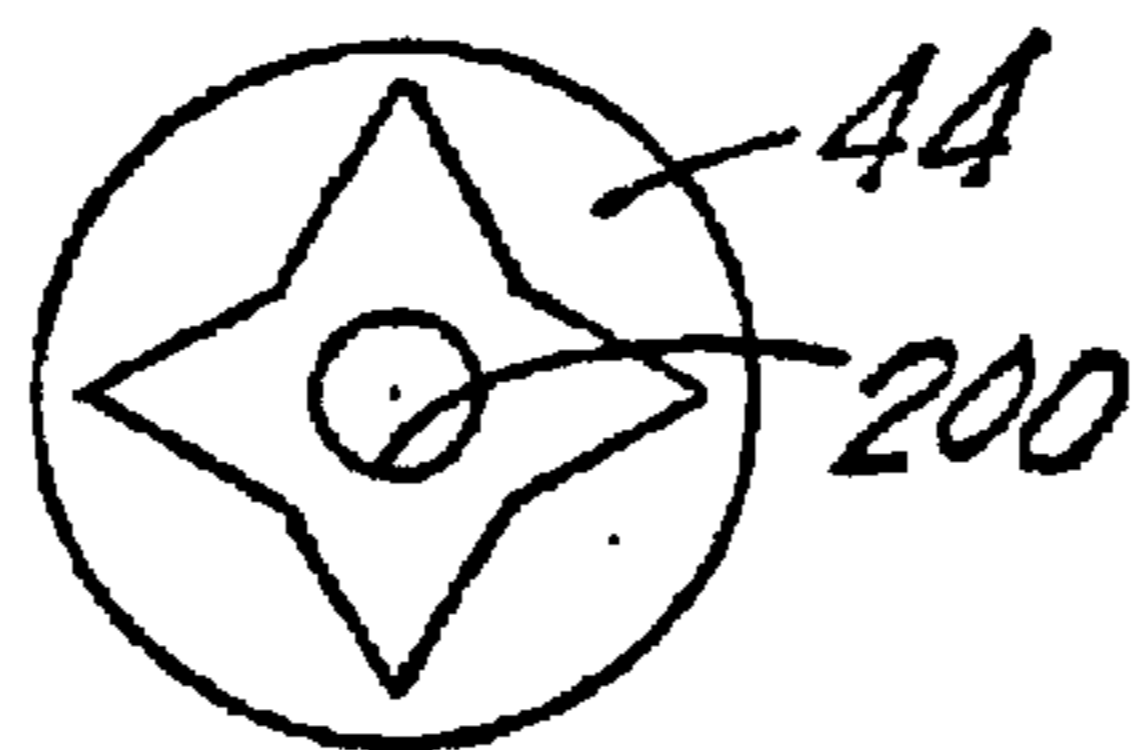

FIG. 19e

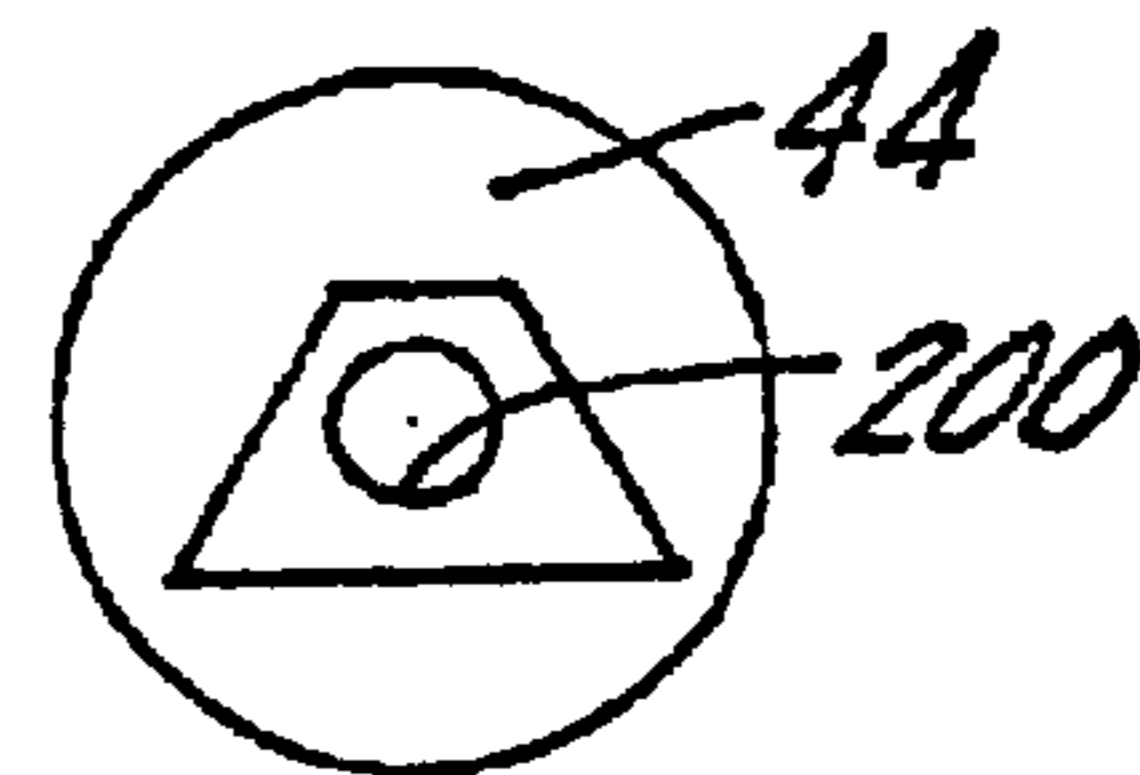

FIG. 19f

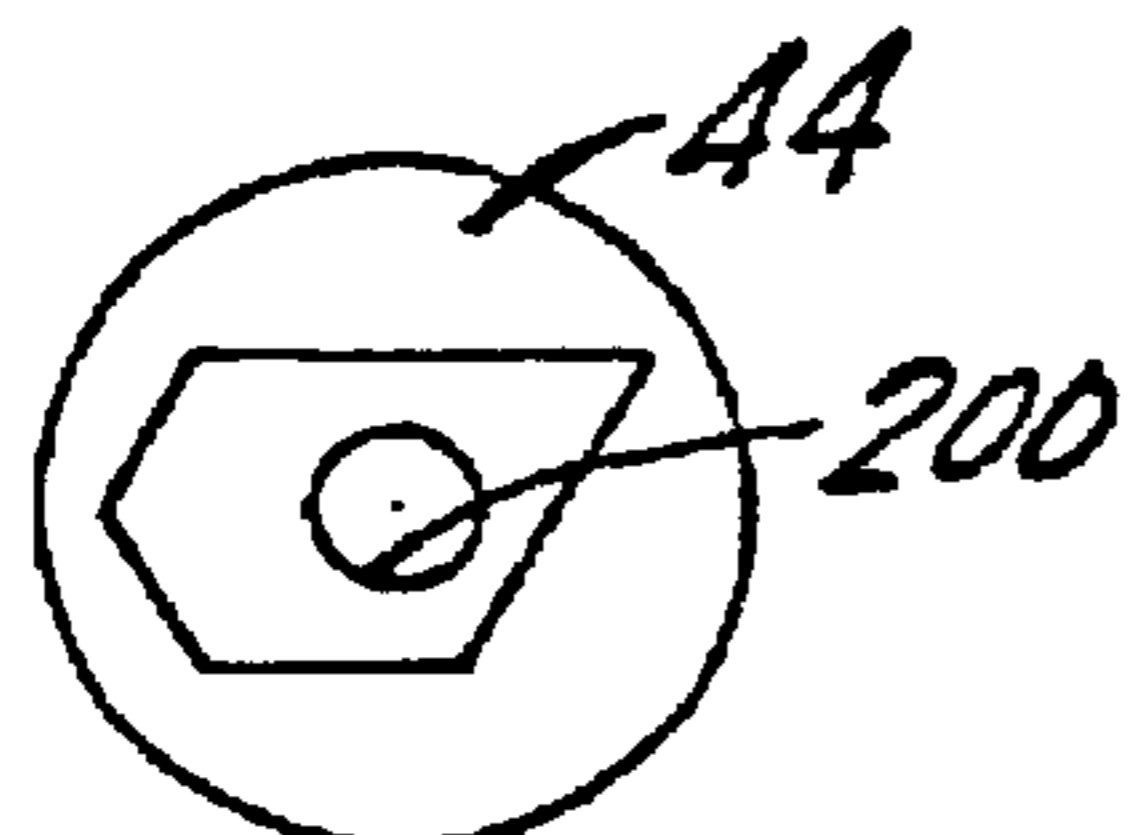

FIG. 19g

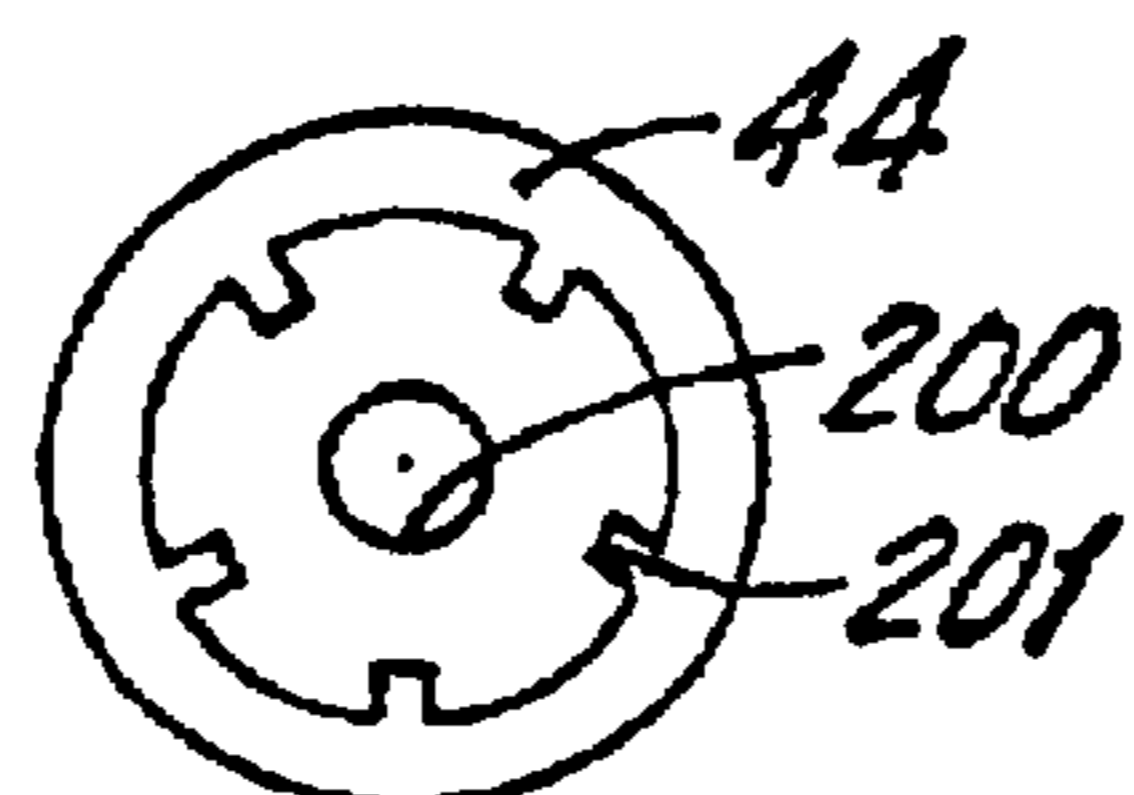

FIG. 19h

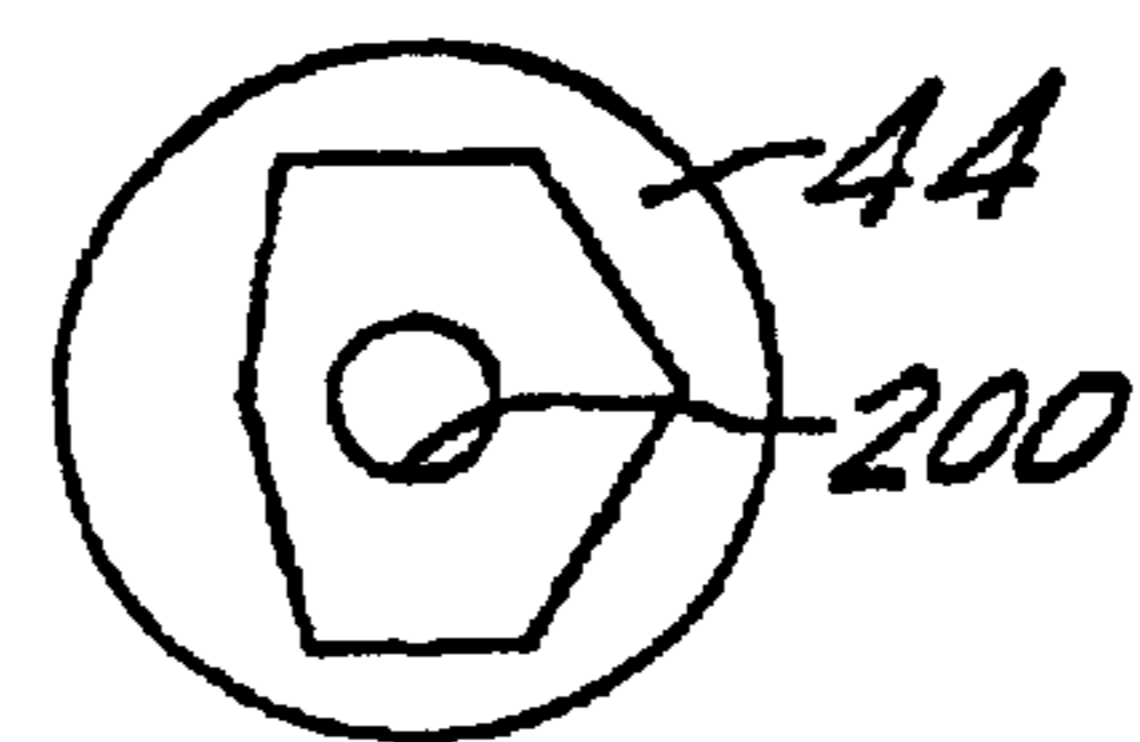

FIG. 19i

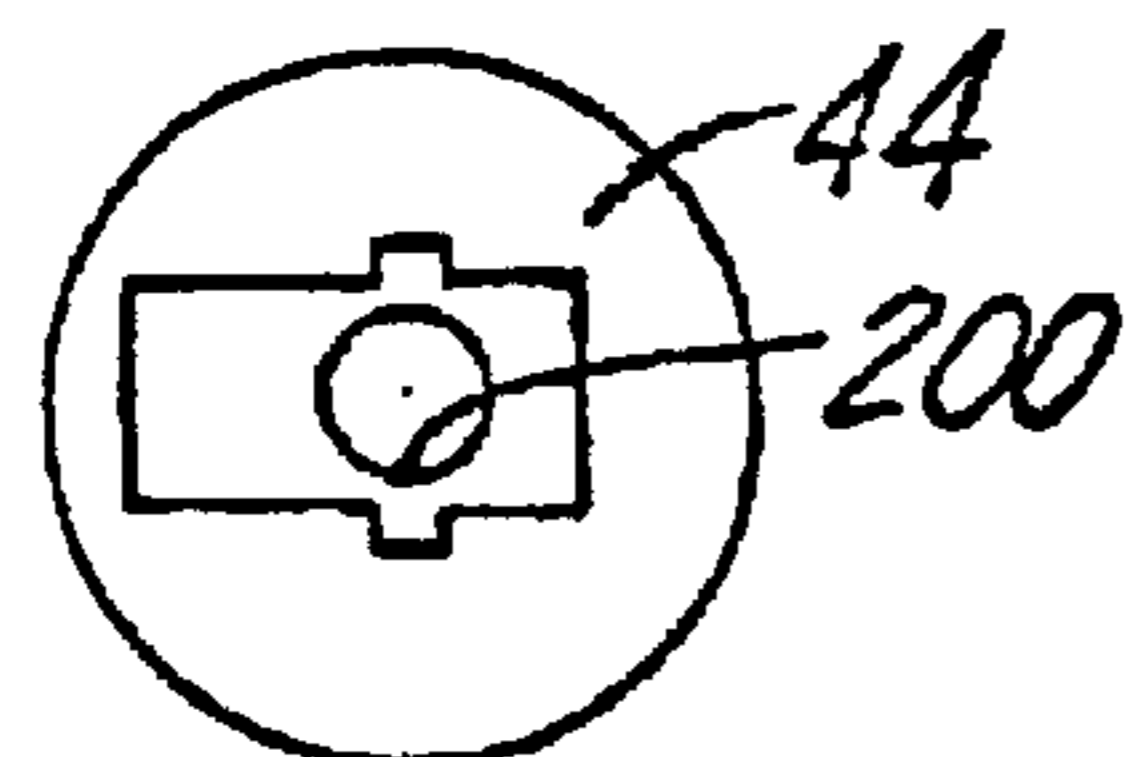

FIG. 19j

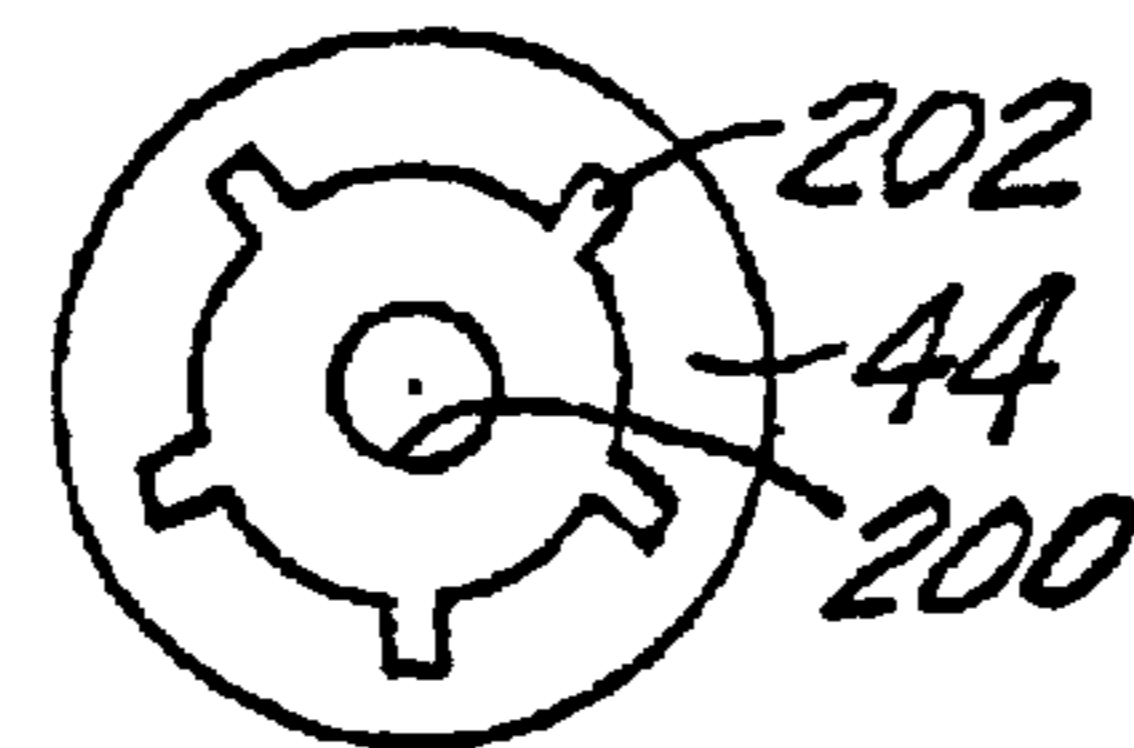

FIG. 19k

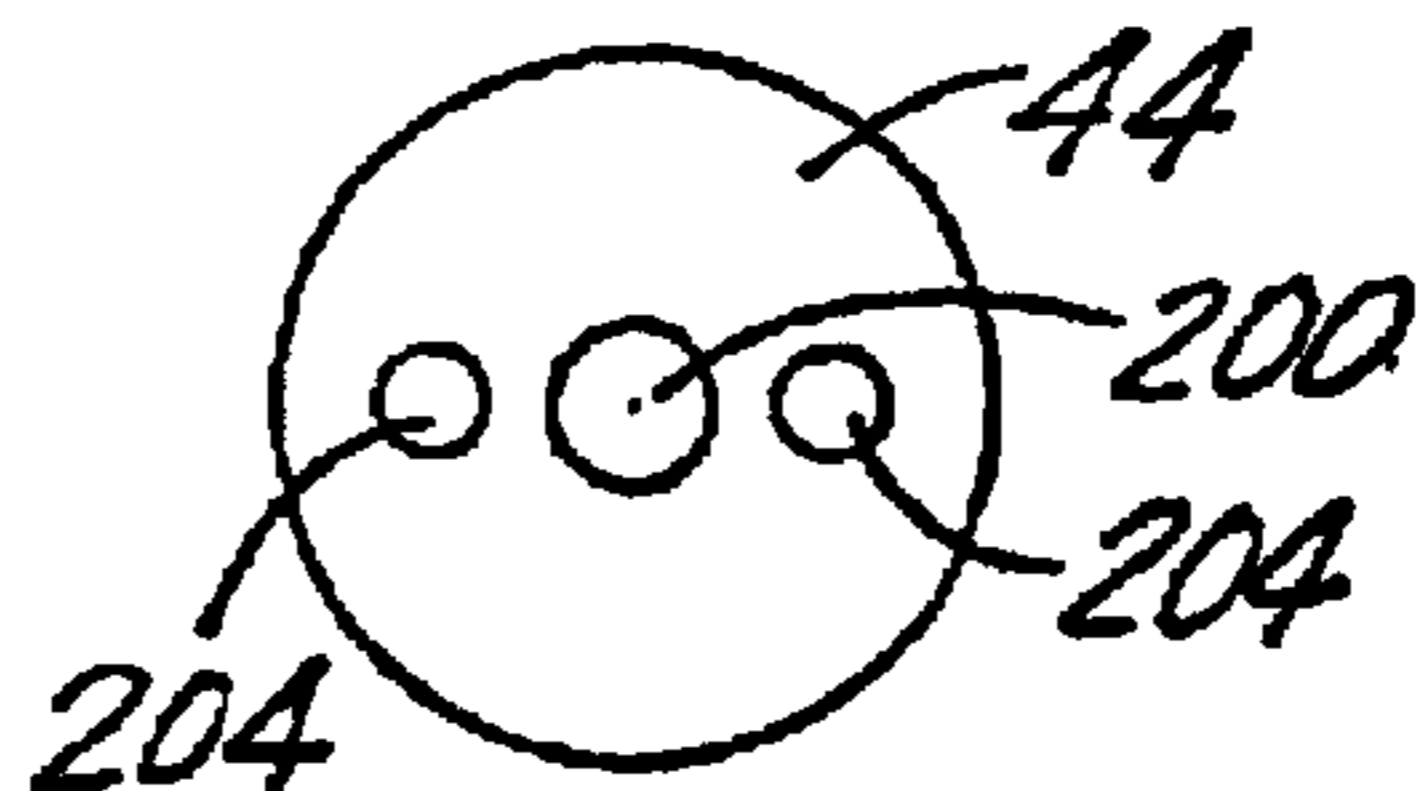

FIG. 19l

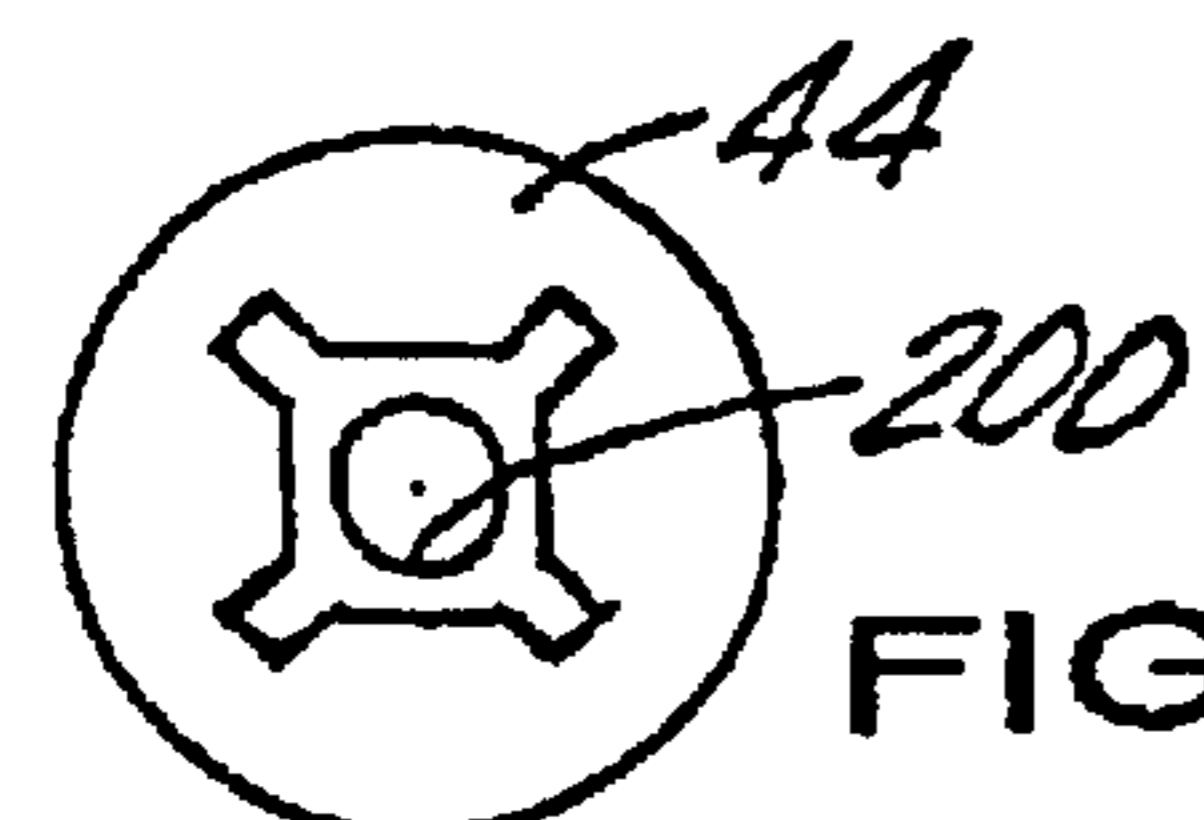

FIG. 19m

DENTAL IMPLANTS AND METHODS FOR EXTENDING SERVICE LIFE

Matter enclosed in heavy brackets [] appears in the original patent but forms no part of this reissue specification; matter printed in italics indicates the additions made by reissue.

This is a continuation in part of Ser. No. 08/380,850, filed Jan. 30, 1995, now U.S. Pat. No. 5,580,246.

BACKGROUND OF THE INVENTION

This invention relates generally to a dental prosthesis and more particularly to a dental prosthesis that is attached to an implant in the bone of a person's jaw.

It is now common when it is desired or necessary to replace a missing tooth or teeth, that the gum is opened and an implant is imbedded in the bone structure beneath the gum. The implant is held initially by friction in a socket formed in the bone or the implant may be threaded into the bone. The gum is then closed over the implant and heals. When a proper material is used for the implant, the bone and implant grow together by a process known as osseointegration so that after several months the implant becomes a permanent part of the bone structure in the mouth. Titanium has been an effective implant material.

Many firms manufacture complete systems of dental implants and prosthetic components for subsequent attachment to the implants. In a typical construction, the implant has an axially threaded hole at its top, that is, the proximal end, near the gum surface. After the implant has integrated with the bone, the gum of the implant is opened to expose the tapped hole. Then an abutment is attached to the tapped hole of the implant and extends to a level above the gum or substantially to the gum surface. The protruding free end of the abutment is constructed for attachment of a prosthesis. For preventing rotation of the prosthesis, the protruding end of the abutment requires a non-round shape and a hexagonal protrusion has been widely used. The abutment also includes a central threaded hole concentric with the threaded hole of the implant and extending inward toward the jaw bone.

A false tooth or crown is provided with a hole therethrough, known in the art as a chimney, and a non-round recess in its base corresponds in shape to the protruding non-round cross section of the abutment. Thereby, the crown can be connected to the abutment and relative rotation between them is prevented so long as critical contours of the abutment and the recess in the crown are maintained.

To prevent the crown from lifting axially from the abutment, a final screw, sometimes known in the dental profession as a "gold screw", is passed into the chimney opening and engages the tapped hole in the implant by way of the abutment so as to hold the crown axially to the abutment and to the implant. Thus, the crown cannot rotate about the abutment or implant because it is mated with the special contours on the exposed end of the abutment. The abutment is similarly mated to the proximal or outer end of the implant. The crown cannot pull away from the abutment when the gold screw has been tightened into place.

Finally, the chimney above the gold screw is filled with a composite material that hardens and is shaped as part of the crown to look like a natural tooth.

There are many variations in construction.

In many instances, the crown is attached directly to a non-round protrusion of the implant and is held directly to the implant by a gold screw without use of an intermediate abutment.

The implant is intended to be a permanent fixture in the jaw bone. The abutment and crown may be replaced if necessary due to damage or poor fit by gaining access to the screw head by way of the chimney, and backing off the screw so that the crown and abutment, if used, can be separated from the implant. Thus, repairs may be made of an abutment and crown with relative convenience.

Whereas dental implantations go back to the days of the Pharaohs in Egypt, use of titanium metal implants that integrate with the bone itself, is a recent development over the last 25 to 30 years. Data so far available on the service life of such implants, indicate that most implants can be expected to have a long service life without complications of the implant itself. However, in a significant percentage of implants, a problem arises because titanium is a relatively soft metal. An unacceptable degree of looseness often develops between the implant and the adjacent abutment or crown whereby there is relative rotation between the implant and the attached elements. This rotational latitude occurs when the contours of the protrusion at the proximal end of the implant become worn as a result of lateral forces applied on the protrusion. Such forces are transmitted from the crown as the crown interacts with adjacent teeth, and perhaps bones, during the course of chewing, biting and nervous grinding (bruxism). Tremendous rotational forces are known to act on the crown. Once there is some degree of freedom for rotation of the crown relative to the implant, the non-rounded contours of the implant protrusion tend more and more toward roundness, and permit more and more rotation. In time, the connection between the implant and the abutment and crown connected thereto does not prevent rotation and is unacceptable.

In these types of failure, for example, where the original protrusion on the implant was hexagonal in shape, it has been found that the corners of the hexagonal shape have been rounded to such a degree that it is not possible to attach a new crown or abutment and prevent rotation relative to the implant.

As stated, this type of rounding on the implant protrusion occurs during normal use of the prosthesis in biting and chewing. Also, the contours of the implant protrusion may become distorted, especially unfavorably rounded or stripped, during the process of threading the implant into the jaw bone. This occurs because the implant protrusion is the means by which the driving tool engages the implant. Therefore, when hard bone is encountered, it is possible that an implant may be damaged beyond usefulness by an ill fitting socket type wrench that engages the outer surfaces of the protrusion and is used to drive-in the implant.

This situation, though costly, is not catastrophic when initially inserting an implant in that the damaged implant may be removed and a new one may be inserted. Unfortunately, after the implant has been joined to the jaw bone by osseointegration, and after years of this condition, it is extremely difficult, costly, and the cause of considerable suffering to the patient, to attempt to remove a damaged implant and replace it with another.

What are needed are a method to rehabilitate in the mouth a damaged implant that no longer holds the crown effectively against rotation, and an improved implant that better resists rotation of an attached abutment and/or crown and thus has an extended service life.

SUMMARY OF THE INVENTION

Accordingly, it is an object of the invention to provide a method for rehabilitating the proximal end of an implant so

as to prevent relative rotation of abutment or crown elements after the initial attachment means has failed.

Another object of the invention is to provide an improved dental implant that reduces the hazards of damage to the implant attachment protrusion during installation and of damage due to crown rotation during normal usage over the life of the prosthesis.

Yet another object of the invention is to reduce the occasions when an implant that has osseointegrated with the jaw bone needs removal in its entirety.

In a method to rehabilitate or replace an implant having a damaged proximal protrusion, such that there is unacceptable rotation between the implant and an attached abutment and/or crown, a jig is slipped over the remaining implant protrusion after removal of the crown and abutment. Guided by the jig, a burr forms radial slots, or other indentations, in the outer surface of the implant adjacent to the protrusion. The slots or other indentations may extend into the implant protrusion. A new abutment (and/or crown) is prepared by techniques that are a modification of casing techniques well known in the dental arts. The bottom surface of the prosthetic device that engages the implant precisely engages the newly-added radial slots or indentations on the implant such that when the final screw is tightened into place, rotation between the implant and the attachments is prevented.

Modified analog implants, copings, and abutments facilitate the method.

Further, an improved implant in accordance with the invention has a proximal protrusion that is generally square in cross section and further includes radial slots for use in threading the implant into the jaw bone. Thereby, no forces need be applied directly to the protrusion's external surfaces when inserting the implant for subsequent osseointegration. In this way, the surfaces of the protrusion that are used to maintain the abutment and/or crown against rotation relative to the implant are not subject to inadvertent damage during installation of the implant in the jaw bone. Further, the rotation resisting surfaces of the squared protrusion are broad and generally continuous and adjacent surfaces meet at 90° angles, or less. Forces tending to rotate the crown have little effect on the holding power of the proximal protrusion even should the edges of the protrusion be removed or become rounded.

In accordance with the invention, radial slots may be formed into the protrusion itself or extend radially from the base of the protrusion. Slots may be provided in different radial directions.

Further, the slots may be omitted whereby the implant, if threaded into the jaw bone, is driven by a tool applied to the protrusion. Many cross sections are available for the protrusion to provide a non-round shape. These cross sections include regular and nonregular convex and nonconvex polygons, rounded shapes, and fluted surfaces.

The invention accordingly comprises the several steps in the relation of one or more of such steps with respect to each of the others to effect rehabilitation of an implant, and the apparatus embodying features of construction, combinations of elements and arrangement of parts which are adapted to effect extended service life for such implants, all as exemplified in the following detailed disclosure, and the scope of the invention will be indicated in the claims.

BRIEF DESCRIPTION OF THE DRAWINGS

For a fuller understanding of the invention, reference is had to the following description taken in connection with the accompanying drawings, in which:

FIG. 1 is a front elevational view, in section, of an implant of the prior art;

FIG. 2 is an exploded view, in perspective, of the dental implant construction of FIG. 1;

FIG. 3 is a top view of the implant of the prior art;

FIGS. 4a, b are top and bottom views, respectively, of a repaired implant and modified crown, in accordance with the invention;

FIGS. 5a, b are respectively an elevational view, in section, and a bottom view of a notching jig in accordance with the invention;

FIGS. 6a, b are front and top views respectively of an abutment in accordance with the invention;

FIG. 7 is a perspective view of a modified implant analog;

FIG. 8 is a flow diagram of methods in accordance with the invention to produce a repaired dental prosthesis;

FIG. 9 is a top view of an alternative embodiment of an implant in accordance with the invention;

FIG. 10a and 10b are a top and side elevation, in section, of another implant of the invention;

FIGS. 11-14 are additional embodiments, in top view, of implants of the invention;

FIG. 15 presents top views of alternative bosses in accordance with the invention;

FIGS. 16-18 are further alternative embodiments, in top view, of implants in accordance with the invention; and

FIGS. 19a-19m are further alternative embodiments, in top view, of implants in accordance with the invention.

DESCRIPTION OF PREFERRED EMBODIMENTS

The present invention is concerned with the problem of rotation of a crown, or an abutment and crown, relative to a dental implant to which the abutment and crown are attached. In many applications, the abutment is omitted and a crown attaches directly to the implant. In every instance, the inherent problem of relative rotation is substantially similar. Accordingly, any description that includes an abutment, or any description that omits use of an abutment, is also applicable to the other construction.

In FIGS. 1-3, a dental prosthesis 10 of the prior art includes an implant 12 embedded in the spongiosa 14 of the jaw bone. After a healing period of several months, the implant 12 has become part of the bony structure by the known process of osseointegration. The implant 12 protrudes through the cortex 16 of the jaw bone, and the gum tissue 18 conceals the proximal end of the implant 12. A tapped hole 20 opens at the proximal end and is accessible between the parted gum tissue 18. The crown 22 usually aligns with the tapped hole 20 in the implant 12.

A hexagonal boss 42 on the implant 12 protrudes above a surface 44 of a flange 45 of the implant 12. The base 46 of the crown 22 includes a hexagonal socket 48, whereby the crown 22 can be removably connected to the implant 12 with the implant boss 42 engaged in the hexagonal socket 48 of the crown 22. Thereby, rotation of the crown 22 about the longitudinal axis 49 of the implant 12 is prevented by the hexagonal cross-section.

Threads 32 of a screw 34 engage the tapped hole 20 until a bevel surface 36 on the screw bead 38 engages a shoulder 40 on the crown 22. Tightening the screw 34 into the threaded hole 20 of the implant 12 draws the crown 22 into a rigid axial connection with the implant 12 and consequently with the bony structure 14, 16 of the jaw.

In attaching the crown **22**, the screw **34** is tightened by means of an Allen-head type tool that engages the hexagonal socket **50** in the screw head **38**. Then the chimney **30** is filled with a filler material, known in the dental arts, and the exposed surface of the filter material is contoured to match the remainder of the crown.

The implant **12** may be screwed into the jaw bone or may be pressed into a prepared socket. When a titanium implant **12** is used, as is the current practice, it is anticipated that an osseointegration process will bind the implant **12** permanently into the jaw after a period lasting three to six months. Then, the crown **22** is prepared to custom fit the integrated implant within the space available between adjacent teeth. Frequently, a gum shaping device or healing cap (not shown) is threaded into the tapped hole **20** and maintained in place while the gum heals after the initial implantation. When screwed into the bone, the implant **12** is driven by attachment of an Allen-head type tool onto the protruding boss **42**. To reduce any hazard of damaging the surfaces of the protrusion **42** while tapping (threading) the socket in the bone, an analog implant (not shown) of material stronger than titanium, e.g. stainless steel, may be used. After the socket is tapped, the actual implant **12** is threaded into the prepared opening. Once the final setting is made, hopefully, the implant will never need removal.

FIG. **3** is a top view of the implant **12**, clearly illustrating a hexagonal boss or protrusion **42** having six planar surfaces **52** that intersect at apexes **54** with 120° angles between them. However, as the apexes **54** become rounded, as illustrated at **54'**, due to forces exerted on the crown during chewing, biting, etc., the overall cross section of the boss **42**, takes on a circular shape and resistance to further rotational relative motion between the implant **12** and the crown **22**, attached thereto by engagement with the boss **42**, diminishes to the point where the utility of the prosthesis is compromised. Repair or replacement becomes necessary.

Whereas an attached crown, which is damaged, can be replaced with relative ease, there is no purpose to such a procedure unless steps are taken to prevent future relative rotation between the crown **22** and the implant **12**.

By a rehabilitation method in accordance with the invention, the proximal end of the implant **12** is modified in vivo by the addition of slots **56** (FIG. **4a**) formed into the surface **44** of the implant **12** adjacent to the boss **42**. ("prime" reference numerals, e.g., **12'**, **22'**, indicate modified or repaired elements.) The ends **58** of the slots **56** preferably do not extend to the circumference **60** of the flange **45** so as to prevent bacterial action which might otherwise occur in those regions, if the slots **56** left small open pockets at the crown/implant interface.

The lower or bottom surface FIG. **4b** of the crown, which may incorporate an abutment, includes a recessed socket **48** wherein the boss or protrusion **42**, although deformed, extends. To complement changes in the implant, the under-surface of the new crown **22'**, in accordance with the invention, also includes protrusions **62** corresponding with the shapes and positions of the slots **56** newly-formed in the implant **12'** such that when the prosthesis is assembled, the radially oriented protrusions **62** on the crown **22'** engage in the slots **56** on the implant **12'** and thereby prevent rotational relative motion between the implant **12'** and the crown **22'**.

Next will be described methods, in accordance with the invention, for rehabilitating an implant **12** in the mouth to provide the constructions illustrated in FIGS. **4a**, **b**, when the implant can no longer maintain the proper rotational orientation with the crown **22** of the prosthesis. This occurs, for

example, because the apexes **54** on the hexagonal boss **42** have become rounded due to the inherent softness of the titanium metal and the tremendous forces exerted on the crown during chewing, biting, etc.

First, the proximal end of the implant **12** is exposed by removal of the crown **22** and an abutment, if one was used intermediate the implant and the crown. As a result, the protrusion or boss **42** and the surface **44** on the implant are exposed to view (FIG. **3**).

These external elements are removed after exposing and backing out the screw **34** via the chimney **30**. Then a notching jig **64** (FIGS. **5a**, **b**) is placed onto the implant **12**. The notching jig **64** includes a bottom interface surface **66** that rests on the exposed flange surface **44** of the implant **12**. A hexagonal socket **68** extends into the bottom surface **66** of the jig **64**, having dimensions such that the protrusion or boss **42** on the implant **12** enters the socket **68** when the surfaces **66**, **44** of the jig and implant are in contact. It should be understood that the socket **68** may be round in section so long as the boss **42** enters and allows seating of the jig **64** with a relatively snug fit to provide alignment.

The notching jig **64** has a long stem with a longitudinal opening **70** through which a threaded screw (not shown) is inserted so as to engage the central opening **20** in the implant **12**. Thus, the jig **64** is axially fixed into position on the implant **12** even though the boss **42** is worn. Guide holes **72** extend from a rear shoulder **74** on the jig **64** to the interface surface **66**. Four guide holes **72** are illustrated; in practice, two guide holes are sufficient when two slots **56** are to be formed in the implant surface **44**.

With the notching jig **64** in place on the implant **12**, the dental practitioner runs a rotating burr through the guide holes **72**, in turn, and forms indentations **56** into the upper surface **44** on the flange **45** of the implant **12**. A stop on the burr or shoulders (not shown) within the guide holes **72** limit the depth of the indentation **56** formed in the surface **44** of the modified implant **12'**. Thus, a configuration as shown in FIG. **4a**, albeit with less precisely rectangularly shaped slots **56**, is produced. The burr shaft diameter, used to make the indentations or slots **56** on the surface **44** of the implant, may be less than the diameter of the guide holes **72**, giving the practitioner latitude of motion so as to shape the slots **56** in the implant **12'**.

Alternatively, the guide holes **72** may be radially oriented ovals (not shown), extending inwardly toward the opening **20** so that the burr may provide extended slots in the implant **12** that cut into the protrusion **42**. These elongated slots, the extensions indicated in FIG. **4a** with broken lines on the boss **42**, may extend nearly into the tapped hole **20**. The longer slot provides a stronger engagement with a driving tool and with the modified crown, which is provided with longer protrusions **62**.

In another embodiment of the method for repair, a notching jig may provide slots only into the boss **42** and not in the flange surface **44**.

Repair of an implant already imbedded in the jaw bone and osseointegrated has been described above, describing the indents formed into the implant as "slots". It should be understood that indentations having contours other than the radial slots illustrated in FIG. **4A** may be provided in the exposed surface of the implant so long as correspondingly configured protrusions are provided on the mating element, for example, the crown or abutment.

It is now necessary that the abutment and crown which ultimately attach to the modified implant **12'** be made to precisely mate with the slots **56** (or other indentations)

formed on the surface **44** of the implant. For the sake of the following description of repair procedures, it is assumed that no separate abutment element is used intermediate the implant and the crown in the completed prosthesis. Further, generally rectangular slots are described; the procedures also apply to indentations of other shapes.

How to make a crown for attachment to an osseointegrated implant in the jaw is well known in the art of dental implants. The same basic procedures are followed in making a crown for the now-modified dental implant **12'**, which is still embedded in the jaw bone, however with slight changes in the elements that are used to accommodate the slots now formed in the flange surface **44** of the implant **12'**. The finished crown must have protrusions on its lower inner surface that interface with the implant to complete the prosthesis.

Therefore, conventional fabrication techniques using a direct pick up impression or an indirect impression would readily be implemented by those skilled in the implantation art without further explanation. However, a brief description (and flow diagram FIG. **8**) is given of several techniques to indicate how the modifications made at the proximal end of the implant affect the procedures.

In a direct pickup technique, after notches or slots **56** are prepared on the implant **12'** with the notching jig **64**, as described above, a direct impression of the modified top of the implant **12'** is made by customizing a resin UCLA-type abutment, using a well-known auto-polymerizing resin. FIGS. **6a, b** illustrate a customized resin UCLA-type abutment **76** made of plastic and having teeth **78** with novel dove-tail spaces **80** between them such that impression material after hardening, will not separate from the abutment although the impression material does bond to the resin abutment.

The customized abutment **76** is attached to the implant **12'** by a guide pin (not shown) that passes through the longitudinal opening **82** in the stem **84** of the abutment **76** and engages the tapped opening **20** in the implant **12'**. Then the impression material is applied to fill the spaces between the abutment **76** and the implant surface **44**. After the impression material has hardened, the guide pin is unscrewed from the implant **12'** and the abutment **76** is removed. Covering the end **86** of the abutment **76** that opposed the implant **12'**, protrusions **62** are present exactly corresponding to the slots **56** newly formed on the implant **12'**.

Then, the customized abutment impression (not shown) is cast into a strong, rigid material e.g. metal. The resultant metal abutment is placed over the implant **12'** in the jaw, and is secured in place with a guide pin that engages the central opening **20** of the implant **12'** by passing through a central opening in the metal abutment that corresponds to the opening **82** that was in the customized UCLA-type abutment **76**. The protrusions **62** are seated in the implant slots **56**.

Then a pick-up impression is made in the mouth in the conventional manner, that is, a window is cut in the top of an impression tray; the tray is filled with impression material and some of this material is positioned around the abutment. Then the filled impression tray is placed over the implant **12'** and metal abutment with the guide pin protruding through the impression material and from the upper surface of the tray. After the impression material has hardened in the tray, the guide pin is unscrewed and the impression tray with the metal abutment now embedded in the impression, is removed from the mouth. The protrusions **62** on the face of the metal abutment are visible in the impression.

A modified implant analog (stainless steel) having slots that correspond with the slots **56** which were formed using

the jig **64**, is positioned on the abutment with the slots on the implant analog receiving therein the protrusions **62** on the metal abutment, which was embedded in the impression. The implant analog is fixed to the abutment with a guide pin, and the assembly is poured in stone, that is, a rigid modeling material. After hardening, the guide pin is removed, and the impression containing the abutment is separated from the stone.

The stone model now positively replicates the portion of the jaw including the implant **12'**. The model includes the analog implant with slots having the exact same dimensions and orientation as those slots **56** in the actual implant **12'** in the jaw bone of the patient.

The metal abutment is now removed from the earlier impression material. The metal abutment was made with protrusions **62** that exactly mate with the analog implant. From this state, a crown is fabricated by well known procedures. The crown incorporates the metal abutment, thus assuring a perfect fit for the crown in the mouth.

Rotation of the crown relative to the modified implant **12'** is prevented by engagement of the protrusions **62** from the abutment with the slots **56** in the exposed surface **44** of the implant **12'**.

In a conventional indirect impression technique, slots **56** (FIG. **4a**) are prepared in the implant **12** in the jaw using the notching jig **64**. An impression coping is attached to the implant **12'** using a guide pin (not shown); the impression coping is conventional except that it has protrusions on its lower surface that correspond with the slots **56** made in the actual implant **12** when the notching jig **64** was used. The drawing of the bottom of a crown (FIG. **4b**) in accordance with the invention also illustrates the modifications (protrusions) to a conventional impression coping's bottom interface surface. Thus, a proper engagement between the prefabricated coping and the implant **12'** is assured.

Then an impression tray with a window cut out of the top is placed over the implant and surrounding portion of the jaw so that the guide pin protrudes. The tray is filled with impression material in a conventional manner. After the impression material has set, the guide pin is unscrewed and the impression is removed from the mouth. An implant analog (e.g. stainless steel) is then abutted with the coping in the impression, with slots being provided on the implant analog to mate with the protrusions, which are extending from the surface of the impression coping. After the implant analog abuts the coping in the impression, the analog and coping are secured together with a guide pin, and a model is poured in stone. The stone model replicates, at least partially, the jaw of the person, however, with the proximal end of the implant analog exposed to view, including its slots in the proper orientation. Then a crown is fabricated by conventional procedures. New materials, namely nylon, gold and aluminum oxide (Al_2O_3) may be used in fabricating the crown on the stone model in this technique.

In the above methods, it has been assumed that the drill jig **64** is used in modifying the implant **12** in the jaw. When this is done, the hardware, namely the copings and analog implants, are pre-manufactured, off-the-shelf items with protrusions and slots that will fit or match the slots that were made in the actual implant in the jaw bone.

However, many practitioners will prefer not to use such a jig **64** and will instead produce a variety of indentations of their own preference on the surface **44** of the implant **12** in the mouth. In such a situation, pre-manufactured implant analogs and pre-manufactured copings with the proper patterns of slots and protrusions, as required, will not be available off-the-shelf.

Therefore, to practice the above procedures, it is necessary to first make a direct pick up from the implant **12'** in the mouth, using a customized UCLA-type abutment **76** (FIGS. **6a, b**) as described above. This impression is then cast in metal and the first procedure as described above is followed with the exception that a modified implant analog must be used in the stone-pouring step. This modified implant analog (FIG. **7**) does not have a flange **45** or boss **42** but is primarily a shank that is internally threaded. Before casting in stone, the modified implant analog is held to the metal abutment in the earlier-formed impression by a guide pin that threadably engages the analog. Then the stone is poured. (Epoxy may be used alternatively in pouring this model) The stone model of the jaw will have the central threaded opening of the analog implant exposed to view. However, the surface with the corresponding slots of the true implant is reproduced in the stone material. From that state, fabrication of a crown is conventional, as before.

Next, an embodiment of an implant in accordance with the invention is discussed, which will reduce the hazards of stripped and damaged boss surfaces that would in time prevent proper mating with an abutment and/or crown. The same reference numerals are used in the description of the improved implants where elements correspond to those of FIGS. **1-6**.

In an implant **90** of FIG. **9**, a boss **92** having a cross section that is a rectangle, in this instance a square, as compared to the hexagonal boss of the prior art, is elevated above the surface **44** of a flange **45** on the implant **90**. As in the earlier embodiments, a tapped hole **20** is at the center of the surface **44**, and a screw **34** ultimately seats in the hole **20** to hold a crown, with an abutment in place. Short slots **94** are recessed into the surface **44** at opposed sides **96** of the square boss **92**. The slots **94** do not reach to the outer circumference **60** of the flange **45** in order to avoid potential bacterial activity at those sites.

Each of the sides **96** of the boss **92** have a greater continuous length as viewed in FIG. **9** than any single side of the hexagonal boss **42** of the prior art (FIG. **3**) for a corresponding circumference **60**. Thus, when, for example, a crown with a square recess on its bottom surface is fitted to the implant **90** with a snug fit to the boss **92**, and is tightened in place with a screw **34**, there is little likelihood that the attached crown will ever rotate relative to the implant. The parallel opposed sides **96** and included 90° angle of the square boss **92** prevent rotation even if the corners of the square-shape should for some reason become rounded.

The boss **92** is bevelled (similar to FIG. **10b**) at its upper edges **93**. Also, the boss **92** may rise vertically from the general plane of the surface **44** or there may be a slight taper in the direction away from the flange **45**. Such a construction makes for easier entry of the boss **92** into a recess, which may also have tapered sides, for example, in a crown.

Additionally, the slots **94** are provided for the purpose of screwing the implant into the bone. The bone is frequently pretapped using a dummy (analog) implant that is made of tougher metal or plastic than the titanium implant itself. The tool which is used for threading the implant **90** into the bone of a patient (not shown) is constructed such that it rotates the implant **90** by tool engagement with the slots **94** and not because of any driving engagement with the sides **96** of the boss **92**. Thus, the surfaces of the boss **92** do not become damaged by the insertion tool upon the initial installation of the implant into the jaw bone, and the contours of the boss **92** are preserved for accurate and effective mating with the abutment and/or crown.

To further assure the fixed relative position between the implant and that which is externally attached to it, the abutment or crown that interfaces with the implant **90** may be made with protrusions that engage in the slots **94** at the interface.

It should also be understood that because of the increased strength of the square boss **92**, the boss may be used when threading the implant into the jaw bone, and the slots **94** may be omitted. In such a use of the boss **92**, the likelihood of serious damage to its surfaces, so as to render its attachment to an abutment and/or crown rotationally unacceptable, is much less than with hexagonal boss **42** of the prior art.

The implant **98** of FIGS. **10a, b**, is similar to the implant **90** of FIG. **9** except that the slots **94'** extending through the boss **92** near to the central opening **20**, such that a blade type tool may be used in the slots **94'** when screwing the implant **98** into the jaw bone.

The slot **94'** may penetrate in depth into the upper surface **100** of the boss **92**, as illustrated with the solid lines in FIG. **10a**. On the other hand, the slot depth may be extended (not shown) substantially, even into the flange **45**, that is, below the surface **44** of the flange **45**. In any event, the slot ends **102** do not extend through to the outer periphery **60** of the flange **45** to reduce hazards of bacterial activity. It is also desirable for similar reasons that the slots do not open into the tapped hole **20**.

For the purpose of increased strength of the boss **92**, if needed, it is possible in manufacture to enlarge the size of the generally square shape and possible lose the perpendicular intersections as indicated by the broken lines **104** in FIG. **10a**. (In all constructions, there is a trade-off between the implant strength and the strength of the attached device.)

In FIG. **11** another embodiment of an implant **106** in accordance with the invention is shown having a generally square elevated boss **92** with slots **94''** running diagonally across the square and extending proximate to the central opening **20**. This provides a longer slot length in the boss itself, but is otherwise similar to the implant **98**. As with the implant **98**, the slot **94''** can penetrate the boss **92** to various depths and may extend to and penetrate into the flange **45**.

Another alternative embodiment (FIG. **12**) provides an implant **108** with an elongated rectangular boss **109** with perpendicularly oriented slots **111** that extend proximate to the central opening **20**. The slots are preferably used exclusively for threading the implant into the jaw bone and the boss **109** is preferably used exclusively for holding the abutment and/or crown against rotation. However, with a proper tool (not shown) applied to the boss, the implant may be threaded into the jaw bone.

In FIG. **13**, an implant **107** includes a generally triangular boss **113** that is penetrated by slots **115, 116** of extended length and selectable (in manufacture) depth that pass through an apex of the triangle.

In FIG. **14**, an implant **117** includes a pair of rectangularly shaped bosses **119** on opposite sides of the tapped hole **20**. A pair of radial slots **121** extend from opposite sides of the tapped hole **20**. In using such an implant **117**, the crown **22'** may have a recess (not shown) on its bottom of rectangular shape that receives both bosses **119** in a single cavity. The bottom surface of the crown may also have protrusions to enter the slots **121**. Alternatively, the bottom surface of the crown may have two smaller rectangular recesses with each of the bosses **119** being received in a respective recess. Protrusions to engage the slots **121** may also be a part of the bottom surface of the crown.

In installing such an implant **117** into the jaw bone, it is preferable that a tool that engages the slots **121** is used

11

without engagement with the protrusions **119** for driving purposes. However, it should be understood that the bosses **119** can be used in driving the implant **117** into the jaw bone and a driving tool can be made for that method. Further, both the slots and the bosses may be used when driving the implant into the jaw bone when a properly mating tool is provided. The implant in FIG. **14** may be considered as a variation on the implant of FIG. **12** in that the two bosses **119** are at opposite ends of an elongated rectangular shape.

In each embodiment, it is intended that the implant be threaded into the jaw bone using only the slots in the proximal implant end. Nevertheless, it is recognized that the boss outlines, whether square, elongated rectangular, triangular, etc., because of their cross sectional bulk and long sides with reduced intersection angles present considerably more resistance to deformation than the prior art hexagonal cross section of the boss **42** (FIGS. **1-3**).

Further, it should be understood that the hexagonal boss, or any shape of the prior art, may be retained (FIG. **4**) in an improved implant with extended slots formed through the boss itself, extending toward the tapped opening **20**. In such a modified conventional implant or new manufacture, the implant may be tapped into the bone at its final installation using the slots, without reliance on the contours of the hexagonal boss itself. In this way, the boss is protected from damage during installation of the implant.

Whereas the figures have illustrated bosses having different polygonal cross sections that are defined by straight lines and crisp intersections of those lines, it should be understood that rounded and bevelled edges, are intended to fall within the scope of the invention. Additionally, any generally axially oriented side surface of a boss may include a bulge or concavity so long as the basic polygonal shape is retained. For examples, FIG. **15** illustrates an elongated rectangular boss that has rounded ends so as to be an oval b. The long sides are concave in a and bulging in c. These are variations of the boss, for example the rectangular boss in FIG. **12**, and for the purposes of this disclosure, are considered to be elongated rectangular (polygonal), possibly including straight and rounded segments, and fall within the scope of the invention. As stated, a trade off must be made between the strength of the boss and the strength of the crown to be attached thereto. The concave configuration a may be used where greater strength is required in the crown, and the bulging configuration c in FIG. **15** may be used where the boss requires increased strength.

FIGS. **16**, **17** and **18** illustrate further alternative embodiments in accordance with the invention of bosses provided with other polygonal cross-sections. In FIG. **16**, four rectangular protrusions or bosses **123** project from the surface **44** to be received in corresponding mating recesses on the crown or abutment. Slots (broken lines) or indentations in the surface **44** may optionally be positioned between the bosses **123**. Two or four slots may be used. The plurality of protrusions or bosses **123**, considered together, provide a non-round shape.

FIG. **17** illustrates a star-shaped polygonal boss **125** extending above the surface **44**. Slots or indentations in the surface **44** may optionally be provided as illustrated with the broken lines.

FIG. **18** illustrates a multi-sided polygonal boss **127** rising from the surface **44** in the form of a trefoil. Again, optional slots are illustrated in broken lines as a trio symmetrically positioned in the surface **44** for use in driving the implant into the bone upon initial implantation.

Additionally, in the discussions above, the implants are described as having a central tapped opening **20**. However,

12

implants are known in the art wherein the central opening is not tapped and may have a non-round cross-section. In such cases, the crown assembly has a post that extends into the central opening of the implant and an adhesive is used to prevent axial motion of the crown relative to the implant after the adhesive has set. A non-round boss as described above in accordance with the invention prevents the rotation of the crown relative to the implant.

Further, the use of screws that pass through the jaw bone and the implant, and in some instances through the post on the crown that is received in a central opening of an implant, is known in the art, for example, U.S. Pat. No. 5,542,847. All such means for maintaining the axial relationship between the crown and the implant when combined with the bosses, slots etc. in accordance with the invention, are intended to fall within the scope of the invention.

Generically speaking, the cross-sectional shape of the boss in accordance with the invention is made non-round such that should the linear edges extending from the surface **44** become rounded there would remain a distinct non-round cross section for the boss. The hexagonal shape of the prior art and any regular polygon cross section having five, six or more regular sides is vulnerable to circular rounding as vertical edges become worn.

On the other hand, convex polygons as shown, for example, in FIGS. **9-16**, present non-round cross sections for the bosses even when the vertical edges become worn and rounded. Additionally, many nonconvex polygons would make excellent boss cross sections and retain their non-round shape and utility even when the linear axial edges are rounded. Further, in production such bosses can be made with beveled or rounded edges, and still be effective for implants.

Further, a generally circular boss cross section can be given holding power against turning by an abutment or crown by use of axially oriented flutes that are formed internally, or externally as teeth. Basic shapes, such as a triangular or square cross section boss may also have supplemental internal or external flutes. Regular hexagonally shaped bosses, by addition of internal and/or external flutes or other formations, maintain a non-round cross section when the axial edges are rounded.

FIGS. **19a-19m** show further alternative embodiments of implants in accordance with the invention. In each instance the protrusion from the surface **44** provides a distinctly non-round cross section while providing good anti-rotational anchorage for an abutment or crown combination regardless of wear that may occur along the vertical edges, as seen in the top views in FIGS. **19a-m**. Each implant has a central opening **200** that may be threaded or non-threaded depending upon the construction of the prosthesis.

Bosses with cross sections that are convex polygons are illustrated in FIGS. **19d, f, g, and i**. FIG. **19c** can be considered as a combination of two convex polygons (triangles) in opposed positions relative to the opening **200**, or the cross section of FIG. **19c** can be considered in its entirety as a nonconvex polygon.

Nonconvex polygons are illustrated in FIGS. **19a, b, e, j, and m**. FIGS. **19h** and **19k** illustrate generally circular bosses that have been given anti-rotational holding power for an abutment or crown by means of internal flutes **201** and external flutes **202**, respectively. FIGS. **19g** and **19i** show cross sections that are distortions of regular hexagons such that a non-round shape is provided even if the vertical edges at the vertices of intersecting sides were rounded.

Each of the polygons can be altered such that sides become concave or convex curves and corners can be

rounded so long as the resultant shape retains the desired non-round characteristic that resist turning and wear by an attached prosthesis element. For example, the boss of FIG. 19g takes on a teardrop shape when the vertical edges are rounded. For enhanced holding power, internal or external flutes may be added to any side surface of the cross sections.

FIG. 191 illustrates the use of circular bosses or protrusions 204 in a symmetrical distribution around the central opening 200. Three, four, or more such protrusions 204 may also be used. The illustrated combination of protrusions in FIG. 191 can be considered a variant of the cross section shown in FIG. 15b. A driving tool usable on the configuration of 15b might also serve with the embodiment of FIG. 191. The combination of protrusions 204, considered together, provides the desired non-round cross section.

In each of the embodiments 19a–m, indentations (not shown) may be provided into the surface 44 for use in threading an implant into the jaw bone, as discussed above.

For the purposes of the descriptions above and the claims that follow, the definitions of different polygons and their features are based upon the school text: Addison-Wesley Geometry, by Stanley R. Clemens, Phares G. O'Daffer, Thomas J. Cooney, John A. Dossey; Addison-Wesley Publishing Co., Inc. Menlo Park, Calif. (1994). In particular, pages 135–140 and later pages, are a source of definitions.

A convex polygon is defined as one in which all diagonals are interior. A nonconvex polygon is one where not all diagonals are interior. A regular polygon is equiangular and equilateral. A trapezoid is a quadrilateral polygon with one pair of parallel sides. A polygon has n sides with the sides meeting at vertices.

Thus, methods for repairing damaged implants in the mouth, and improved implants have been presented. All of those devices that engage the repaired implant, are provided with recesses and protrusions, as required. However, a crown, for example, having a recess with a square cross section so as to match an implant of FIG. 10a, need not have protrusions that match the slots 94', as these slots are basically intended for installing the implant in the jaw bone. Nevertheless, as a redundancy measure and for additional anti-rotation resistance, protrusions on the crown's lower surface that correspond with the slots may also be included in conjunction with the squared recess.

It is contemplated that in practicing the methods, a kit of parts will be purchased from a dental supplier. The kit for those practitioners using preferred methods includes a notching jig 64 and an appropriate burr (not shown) to fit the guide holes 72. Also in the kit may be an implant analog having preformed slots 56 on its proximal end, and an impression coping having protrusions 62 on its lower end. A modified UCLA-type abutment with dove-tail teeth may also be in such a kit, although it could be purchased separately. A different kit for a practitioner who prefers not to use the notching jig may instead include a UCLA-type abutment and a modified implant analog that has no flange 45.

It should also be understood that a reversal of features is intended to fall within the inventions scope. Thus any boss cross-section which has been described as protruding from the flange surface 44 may also be formed (and viewed in the Figures) as a recess in the surface 44. In such a construction the mating crown or abutment is fabricated with a correspondingly shaped protrusion (or protrusions) that seat(s) in the recess (or recesses).

It will thus be seen that the objects set forth above, among those made apparent from the preceding description, made

in carrying out the above methods and in the articles set forth without departing from the spirit and scope of the invention, it is intended that all matter contained in the above description and shown in the accompanying drawings shall be interpreted as illustrative and not in a limiting sense.

What is claimed is:

1. A dental implant for insertion in the jaw bone of a patient, comprising:

an elongated body having a longitudinal axis and a proximal surface generally transverse to said longitudinal axis,

a boss extending from said proximal surface, said boss having a transverse face, generally axial extended side surfaces, and a non-round cross section as viewed along said axis,

at least one indentation penetrating [at least one] of said proximal surface of said body and said transverse face of said [implant] boss, said at least one indentation being adapted to engage an insertion device or at least one protrusion of a dental prosthesis or an abutment so as to fix the position of the prosthesis or abutment relative to said implant.

2. A dental implant as in claim 1, wherein said non-round cross section is polygonal.

3. An implant as in claim 1 wherein said non-round cross section is defined by said side surfaces and selected from the group consisting of a convex polygon, nonconvex polygon, a closed periphery of curved surfaces, and a closed periphery being a combination of curved segments and linear segments.

4. A dental implant as in claim 1, wherein said non-round cross section is selected from the group consisting of generally square, hexagonal, pentagonal, elongated rectangular, oval, triangular, star-shaped, trefoil shaped, trapezoid-shaped, rounded with fluting, polygonal with fluting, nonconvex polygonal, and nonregular polygonal.

5. An implant as in claim 1, wherein said side surfaces have flutes, said flutes being selected from the group consisting of internal flutes and external flutes.

6. A dental implant as in claim 1, wherein said boss includes a plurality of protrusions from said proximal surface, said protrusions from said proximal surface considered together providing said non-round cross section.

7. A dental implant for insertion in the jaw bone of a patient, comprising:

an elongated body having a longitudinal axis and a proximal surface generally transverse to said longitudinal axis, a boss extending from said proximal surface, said boss having a transverse face, axial extended side surfaces, and a non-round cross section as viewed along said axis,

said non-round cross section being defined by said side surfaces and selected from the group consisting of a convex polygon, nonconvex polygon, a closed periphery of curved surfaces, and a close periphery that is a combination of curved segments and linear segments, wherein said boss includes a plurality of protrusions from said proximal surface, said protrusions from said proximal surface considered together providing said non-round cross section.

8. A dental implant as in claim 7 wherein said non-round cross section is selected from the group consisting of generally square, hexagonal, pentagonal, elongated rectangular, oval, triangular, star-shaped, trefoil shaped, trapezoid-shaped, rounded with fluting, polygonal with fluting, nonconvex polygonal, and nonregular polygonal.

15

9. A dental implant for insertion in the jaw bone of a patient, comprising:

an elongated body having a longitudinal axis and a proximal surface generally transverse to said longitudinal axis, a boss extending from said proximal surface, said boss having a transverse face, axially extending side surfaces, and a non-round cross section as viewed along said axis,

said non-round cross section being defined by said side surfaces and selected from the group consisting of generally trefoil, quatrefoil, trapezoid, convex polygon with noncongruent sides, nonconvex irregular polygon, nonregular polygon, tear-shaped convex, and nonrectangular parallelogram cross sections.

10. An implant as in claim 9, wherein said side surfaces have flutes, said flutes being selected from the group consisting of internal flutes and external flutes.

11. An implant as in claim 9, wherein said boss cross-section is asymmetric relative to said longitudinal axis.

12. An implant assembly comprising:

(i) a dental implant for insertion in the jaw bone of a patient, comprising:

an elongated body having a longitudinal axis and a proximal surface generally transverse to said longitudinal axis,

a boss extending from said proximal surface, said boss having a transverse face, generally axial extended side surfaces, and a non-round cross section as viewed along said axis,

at least one indentation penetrating said transverse face of said boss and said proximal surface of said body,

(ii) a dental prosthesis or abutment or impression coping for attachment to said implant, comprising, at a surface that engages said implant, at least one protrusion which engages with said at least one indentation so as to fix the position of the dental prosthesis or abutment or impression coping relative to said implant.

13. A dental implant for insertion in the jaw bone of a patient, comprising:

an elongated body having a longitudinal axis and proximal surface generally transverse to said longitudinal axis,

16

a boss extending from said proximal surface, said boss having a transverse face and generally axial extended side surfaces,

at least one indentation penetrating said transverse face of said boss and said proximal surface of said body, said at least one indentation being adapted to engage an insertion device or at least one protrusion of a dental prosthesis or abutment so as to fix the position of the abutment or crown relative to said implant.

14. A dental implant for insertion in the jaw bone of a patient, comprising:

an elongated body having a longitudinal axis and an axial hole, said body having a proximal end that terminates in a proximal surface that is generally transverse to said longitudinal axis,

a recess extending into said proximal surface, said recess having a bottom wall including an opening that communicates with said axial hole, and smooth, generally axial extended side surfaces, and

a plurality of slots penetrating said proximal surface and axially extending only part way down said side surfaces toward said bottom wall, said slots being adapted to engage an insertion device or at least one protrusion of a dental prosthesis or abutment so as to fix the position of the abutment or crown relative to said implant.

15. A dental implant as in claim 16, wherein said body includes an enlarged end.

16. A dental implant as in claim 16, wherein said recess includes a beveled surface.

17. A dental implant as in claim 16, wherein said elongated body includes screw threads around its exterior beneath said enlarged end, and a diameter of said enlarged end is greater than a diameter of said screw threads.

18. A dental implant as in claim 19, wherein said enlarged end includes a circular flange.

19. A dental implant as in claim 16, wherein said recess has curved side surfaces.

20. A dental implant as in claim 16, wherein said slots have flat sides that intersect in substantially right angles.

21. A dental implant as in claim 16, wherein said bottom wall of said recess is substantially planar.

22. A dental implant as in claim 16, wherein said axial hole is threaded.

* * * * *

UNITED STATES PATENT AND TRADEMARK OFFICE
CERTIFICATE OF CORRECTION

PATENT NO. : RE 38,945 E
APPLICATION NO. : 09/667827
DATED : January 24, 2006
INVENTOR(S) : Paula S. Fried et al.

Page 1 of 2

It is certified that error appears in the above-identified patent and that said Letters Patent is hereby corrected as shown below:

In the claims:

In claim 1, lines 17-18, please delete "at least one indentation penetrating [at least one] of said proximal surface" and replace with --at least one indentation penetrating [at least one of] said proximal surface--.

In claim 14, lines 16-19, please delete "*a recess extending into said proximal surface, said recess having a bottom wall including an opening that communicates with said axial hole,*" and replace with --*a recess extending into said proximal surface, said recess having a bottom wall including an opening that communicates with said axial hole,*--.

In claim 15, line 25, please delete "*A dental implant as in claim 16,*" and replace with --*A dental implant as in claim 14,*--.

In claim 16, line 27, please delete "*A dental implant as in claim 16,*" and replace with --*A dental implant as in claim 14,*--.

In claim 18, line 33, please delete "*A dental implant as in claim 19,*" and replace with --*A dental implant as in claim 17,*--.

In claim 19, line 35, please delete "*A dental implant as in claim 16,*" and replace with --*A dental implant as in claim 14,*--.

In claim 20, line 37, please delete "*A dental implant as in claim 16,*" and replace with --*A dental implant as in claim 14,*--.

In claim 21, line 39, please delete "*A dental implant as in claim 16,*" and replace with --*A dental implant as in claim 14,*--.

In claim 22, line 41, please delete "*A dental implant as in claim 16,*" and replace with --*A dental implant as in claim 14,*--.

UNITED STATES PATENT AND TRADEMARK OFFICE
CERTIFICATE OF CORRECTION

PATENT NO. : RE 38,945 E
APPLICATION NO. : 09/667827
DATED : January 24, 2006
INVENTOR(S) : Paula S. Fried et al.

Page 2 of 2

It is certified that error appears in the above-identified patent and that said Letters Patent is hereby corrected as shown below:

In the claims:

After claim 22, please insert the following claims 23-27:

- 23. *A dental implant for insertion in the jaw bone of a patient, comprising:
an elongated body having a longitudinal axis and an axial hole, said body
having a proximal surface generally transverse to said longitudinal axis,
a boss extending from said proximal surface, said boss having a transverse
face, generally axially extended side surfaces, and a polygonal cross section as viewed
along said axis, and
opposing slots penetrating said transverse face of said boss, said slots being of
substantially equal width and mutually aligned with one another.*
24. *A dental implant as in claim 23, wherein the end of said elongated body having
said proximal surface is enlarged relative to the rest of said elongated body.*
25. *A dental implant as in claim 24, wherein said elongated body is substantially
cylindrical, and includes a screw thread circumscribing its exterior.*
26. *A dental implant as in claim 25, wherein said polygonal cross section is a regular
polygon having sides of equal length.*
27. *A dental implant as in claim 26, wherein said regular polygon is a square.--.*

Signed and Sealed this

First Day of December, 2009

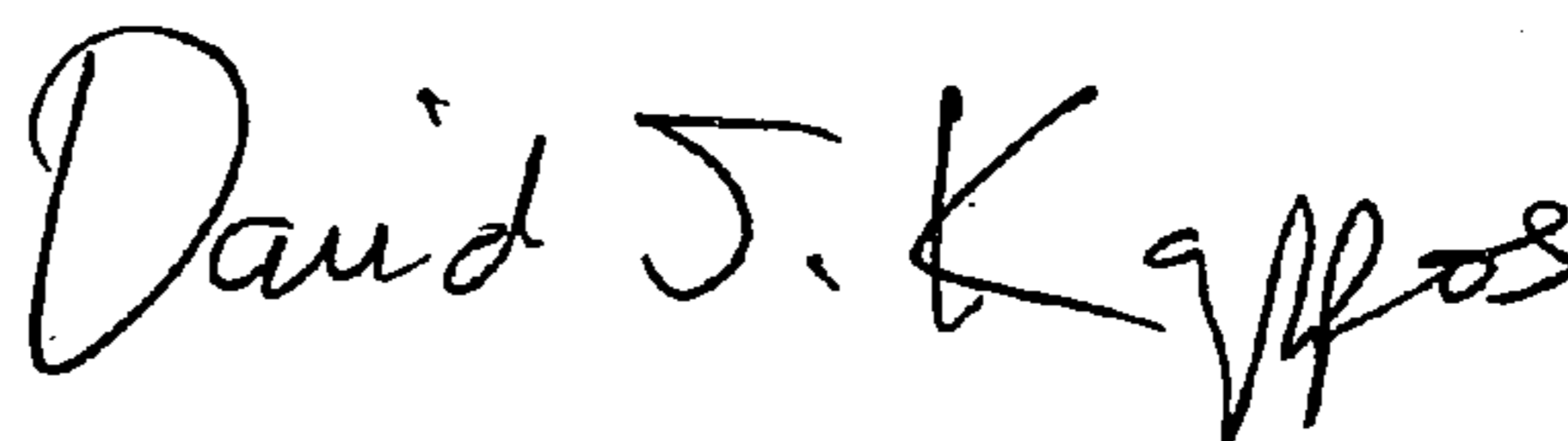

David J. Kappos
Director of the United States Patent and Trademark Office

UNITED STATES PATENT AND TRADEMARK OFFICE
CERTIFICATE OF CORRECTION

PATENT NO. : RE 38,945 E
APPLICATION NO. : 09/667827
DATED : January 24, 2006
INVENTOR(S) : Paula S. Fried et al.

Page 1 of 2

It is certified that error appears in the above-identified patent and that said Letters Patent is hereby corrected as shown below:

In the claims:

Column 14, In claim 1, lines 17-18, please delete "at least one indentation penetrating [at least one] of said proximal surface" and replace with --at least one indentation penetrating [at least one of] said proximal surface--.

Column 16, In claim 14, lines 16-19, please delete "*a recess extending into said proximal surface, said recess having a bottom wall including an opening that communicates with said axial hole,*" and replace with --*a recess extending into said proximal surface, said recess having a bottom wall including an opening that communicates with said axial hole,*--.

Column 16, In claim 15, line 25, please delete "*A dental implant as in claim 16,*" and replace with --*A dental implant as in claim 14,*--.

Column 16, In claim 16, line 27, please delete "*A dental implant as in claim 16,*" and replace with --*A dental implant as in claim 14,*--.

Column 16, In claim 18, line 33, please delete "*A dental implant as in claim 19,*" and replace with --*A dental implant as in claim 17,*--.

Column 16, In claim 19, line 35, please delete "*A dental implant as in claim 16,*" and replace with --*A dental implant as in claim 14,*--.

Column 16, In claim 20, line 37, please delete "*A dental implant as in claim 16,*" and replace with --*A dental implant as in claim 14,*--.

Column 16, In claim 21, line 39, please delete "*A dental implant as in claim 16,*" and replace with --*A dental implant as in claim 14,*--.

Column 16, In claim 22, line 41, please delete "*A dental implant as in claim 16,*" and replace with --*A dental implant as in claim 14,*--.

UNITED STATES PATENT AND TRADEMARK OFFICE
CERTIFICATE OF CORRECTION

PATENT NO. : RE 38,945 E
APPLICATION NO. : 09/667827
DATED : January 24, 2006
INVENTOR(S) : Paula S. Fried et al.

Page 2 of 2

It is certified that error appears in the above-identified patent and that said Letters Patent is hereby corrected as shown below:

In the claims:

Column 16, After claim 22, line 43, please insert the following claims 23-27:

- 23. *A dental implant for insertion in the jaw bone of a patient, comprising:
an elongated body having a longitudinal axis and an axial hole, said body
having a proximal surface generally transverse to said longitudinal axis,
a boss extending from said proximal surface, said boss having a transverse
face, generally axially extended side surfaces, and a polygonal cross section as viewed
along said axis, and
opposing slots penetrating said transverse face of said boss, said slots being of
substantially equal width and mutually aligned with one another.*
24. *A dental implant as in claim 23, wherein the end of said elongated body having
said proximal surface is enlarged relative to the rest of said elongated body.*
25. *A dental implant as in claim 24, wherein said elongated body is substantially
cylindrical, and includes a screw thread circumscribing its exterior.*
26. *A dental implant as in claim 25, wherein said polygonal cross section is a regular
polygon having sides of equal length.*
27. *A dental implant as in claim 26, wherein said regular polygon is a square.--.*

This certificate supersedes the Certificate of Correction issued December 1, 2009.

Signed and Sealed this

Twenty-second Day of December, 2009

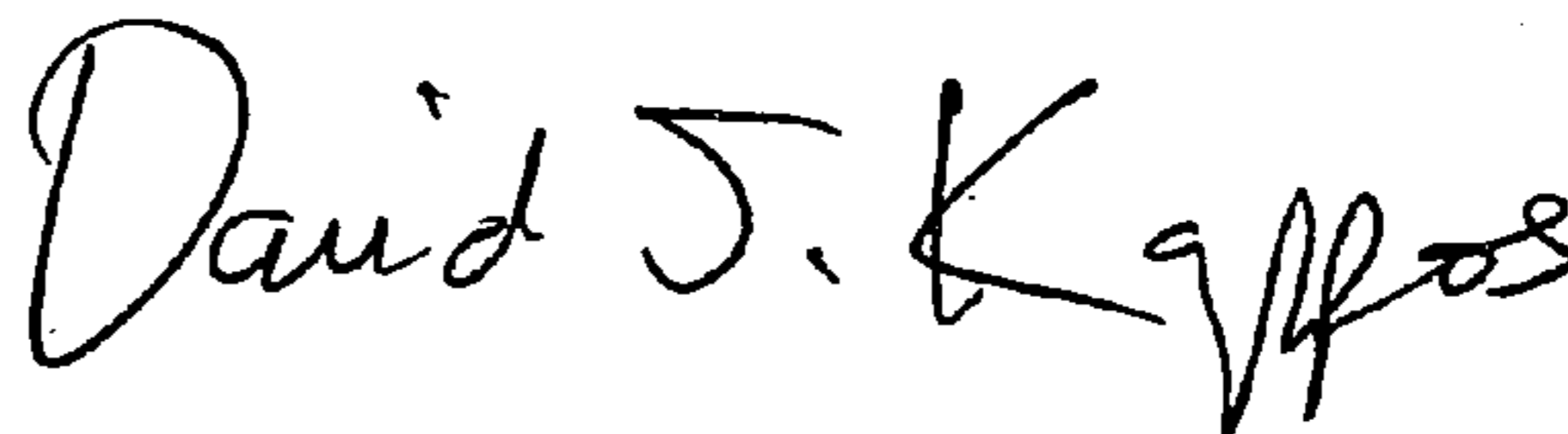

David J. Kappos
Director of the United States Patent and Trademark Office

UNITED STATES PATENT AND TRADEMARK OFFICE
Certificate

Patent No. RE38,945 E

Patented: January 24, 2006

On petition requesting issuance of a certificate for correction of inventorship pursuant to 35 U.S.C. 256, it has been found that the above identified patent, through error and without any deceptive intent, improperly sets forth the inventorship.

Accordingly, it is hereby certified that the correct inventorship of this patent is: Paula S. Fried, Bayside, NY (US); Leonard Cooper, Pelham Manor, NY (US); and Leonard Marotta, West Islip, NY (US).

Signed and Sealed this Nineteenth Day of April 2011.

CRIS L. RODRIGUEZ
Supervisory Patent Examiner
Technology Center 3700