

US00RE38863E

(19) **United States**
 (12) **Reissued Patent**
Tchao

(10) **Patent Number: US RE38,863 E**
 (45) **Date of Reissued Patent: Nov. 1, 2005**

(54) **CHEMOTAXIS ASSAY PROCEDURE**
 (76) Inventor: **Ruy Tchao**, 404 Cedar La., Flourtown,
 PA (US) 19031
 (21) Appl. No.: **09/966,831**
 (22) Filed: **Sep. 28, 2001**

Related U.S. Patent Documents

Reissue of:

(64) Patent No.: **5,601,997**
 Issued: **Feb. 11, 1997**
 Appl. No.: **08/383,058**
 Filed: **Feb. 3, 1995**

U.S. Applications:

(63) Continuation of application No. 09/472,490, filed on Dec.
 23, 1999.
 (51) **Int. Cl.⁷** **C12Q 1/02**
 (52) **U.S. Cl.** **435/29; 435/34**
 (58) **Field of Search** 422/101; 435/29,
 435/30, 34, 285, 300, 301

(56) **References Cited****U.S. PATENT DOCUMENTS**

4,304,710 A 12/1981 Taylor et al.
 4,563,418 A 1/1986 Ward, Jr.
 4,912,037 A * 3/1990 Lemonnier 435/34
 4,912,057 A * 3/1990 Guirguis et al. 435/288.4
 4,920,063 A 4/1990 Ward, Jr.
 4,935,223 A 6/1990 Phillips
 4,986,979 A 1/1991 Morgan, Jr. et al.
 5,166,079 A 11/1992 Blackwood et al.
 5,210,021 A * 5/1993 Goodwin, Jr. 435/29
 5,250,443 A 10/1993 Lindholm et al.
 5,284,753 A * 2/1994 Goodwin, Jr. 435/30
 5,302,515 A * 4/1994 Goodwin, Jr. 435/29
 5,382,523 A 1/1995 Hoenes et al.
 5,416,005 A 5/1995 Blankemeyer
 5,443,816 A 8/1995 Zamora et al.
 5,459,070 A 10/1995 Blankemeyer
 5,464,818 A 11/1995 Yamaguchi et al.
 5,569,585 A 10/1996 Goodwin et al.
 5,618,513 A 4/1997 Srinivasan
 5,670,133 A 9/1997 Zamora

FOREIGN PATENT DOCUMENTS

EP 127 106 A2 12/1984
 EP 127 106 B1 12/1984
 EP 0 294 105 12/1988
 EP 0 450 519 A2 10/1991
 GB 1 519 242 7/1978
 GB 1581766 * 12/1980
 GB 1 581 766 12/1980
 JP 51-40191 4/1976
 JP 54-97094 7/1979
 JP 55-104898 8/1980
 JP 55-124048 9/1980
 JP 57-182638 11/1982
 JP 59-113899 6/1984
 JP 59-193360 11/1984
 JP 60-17357 1/1985
 JP 60-17358 1/1985
 JP 60-104260 6/1985
 JP 61-247377 11/1986
 JP 62-61598 3/1987

JP 62-135766 6/1987
 JP 62-138185 6/1987
 JP 62-223147 10/1987
 JP 63-112975 5/1988
 JP 1-196299 8/1989
 JP 2-280034 11/1990
 JP 3-501884 4/1991
 JP 3-502370 5/1991
 JP 4-503005 6/1992
 JP 5-219934 8/1993
 JP 5-508556 12/1993
 JP 7-44707 2/1995
 JP 8-71531 3/1996
 JP 7-505297 6/1996
 JP 8-505530 6/1996
 JP 9-500865 1/1997
 JP 9-121889 5/1997
 JP 9-215490 8/1997
 WO WO 90/05914 5/1990
 WO WO 91/01490 2/1991
 WO WO 94/10553 5/1994
 WO WO 96/13711 5/1996
 WO WO 96/17961 6/1996

OTHER PUBLICATIONS

Stephen Boyden, Ph.D., "The Chemotactic Effect of Mix-
 tures of Antibody and Antigen on Polymorphonuclear Leu-
 cocytes," J. Exp. Med., 115:pp. 453-466, (1961).*
 Zichia et al., A New Direct Viewing Chemotaxis Chamber,
 Journal of Cell Science, 99, 769-775 (1991).*
 Wilkinson, Micropore Filter Methods of Leukocyte Chemo-
 taxis, Methods in Enzymology, 162, 38-50, (1988).*
 NeuroProbe MB Series Microtiter Plate Chambers, Neuro-
 Probe, Inc. (1994).*
 Shi et al., 1993:497168 BIOSIS, abstracting Journal of
 Immunological Methods, (1993), vol. 164, No. 2, pp.
 149.154.
 Watanabe et al., 1989:448352 BIOSIS, abstracting J. Phar-
 macol. Methods, (1989), 22(1), pp. 13-18.

* cited by examiner

Primary Examiner—Leslie Wong

(74) Attorney, Agent, or Firm—Hoffmann & Baron, LLP

(57) **ABSTRACT**

A chemotaxis assay procedure which is non-destructive of
 the cells being studied, which permits the ready performance
 of kinetic or time-dependent study of cell migration from the
 same sample, and which produces objective measurements
 includes the steps of:(a)labeling cells with a dye; (b) placing
 the labeled cells in a first chamber; (c) placing a chemical
 agent in a second chamber adjacent to said first chamber; (d)
 separating said first chamber from said second chamber with
 a radiation opaque membrane, said radiation opaque mem-
 brane having a plurality of substantially perpendicular trans-
 verse pores therein; (e) stimulating the labeled cells on the
 side of the membrane closest to said second chamber with
 electromagnetic radiation of a first wavelength whereby said
 labeled cells will emit electromagnetic radiation of a second
 wavelength; and (f) measuring the emitted electromagnetic
 radiation from the side of the radiation opaque membrane
 closest to the second chamber; wherein said radiation
 opaque membrane comprises a film which is not substan-
 tially transmissive to at least one of said first and second
 wavelengths of electromagnetic radiation. The radiation
 opaque membrane may comprise a dyed film or a film which
 has at least one radiation blocking layer applied thereto.

19 Claims, 7 Drawing Sheets

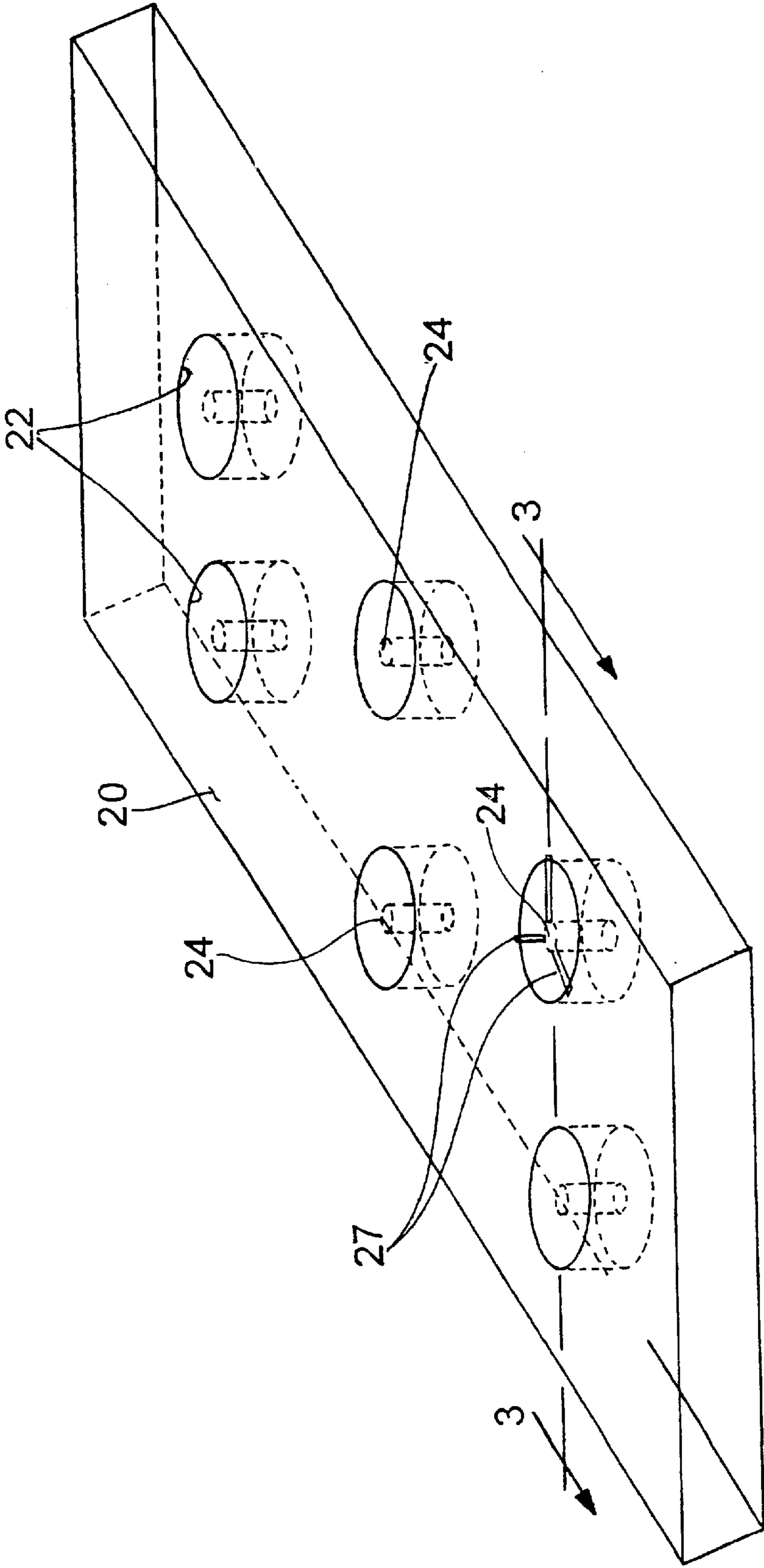

Fig. 1

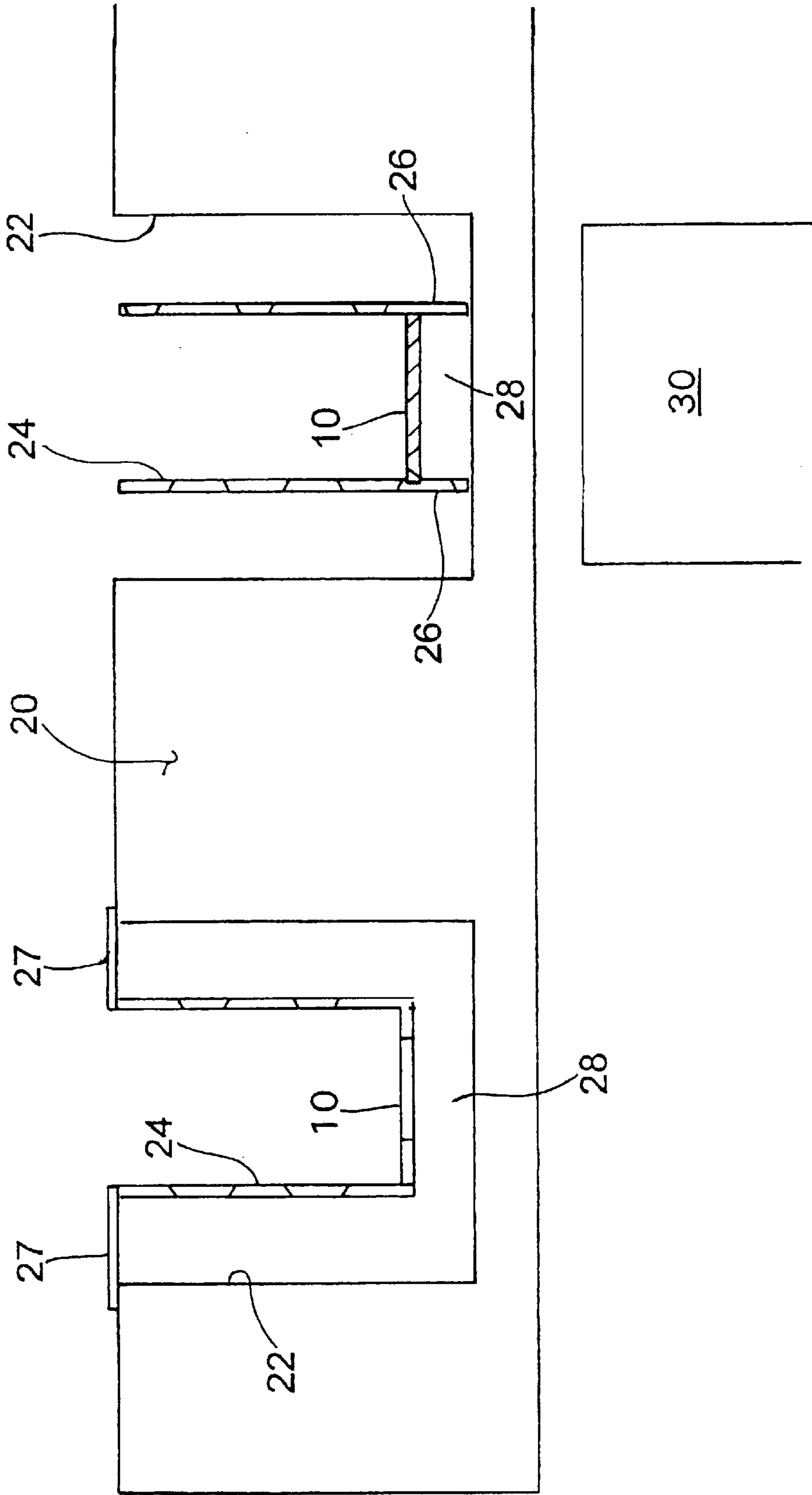

Fig. 2

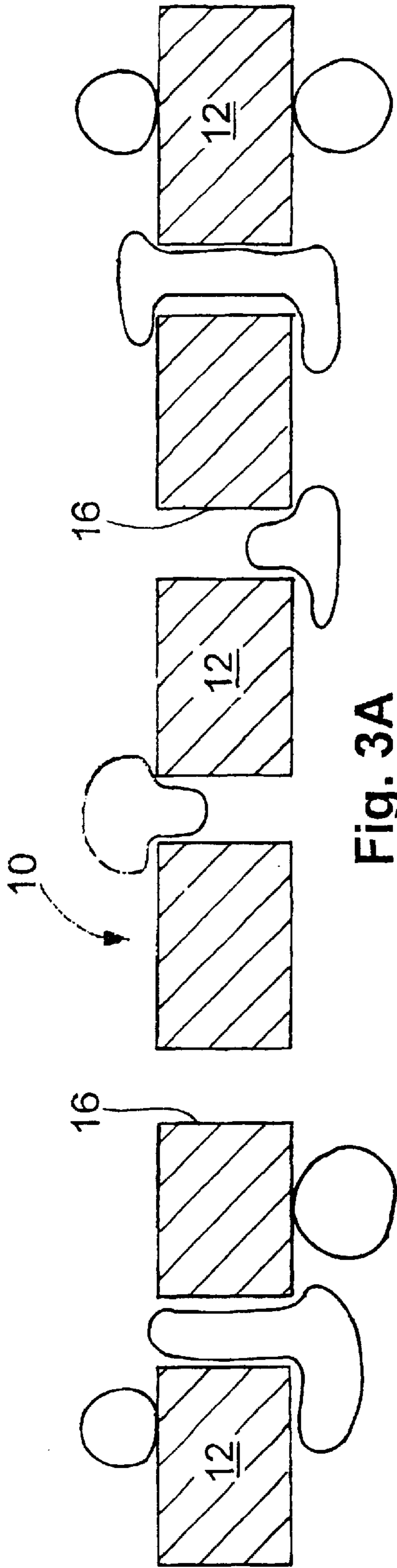

Fig. 3A

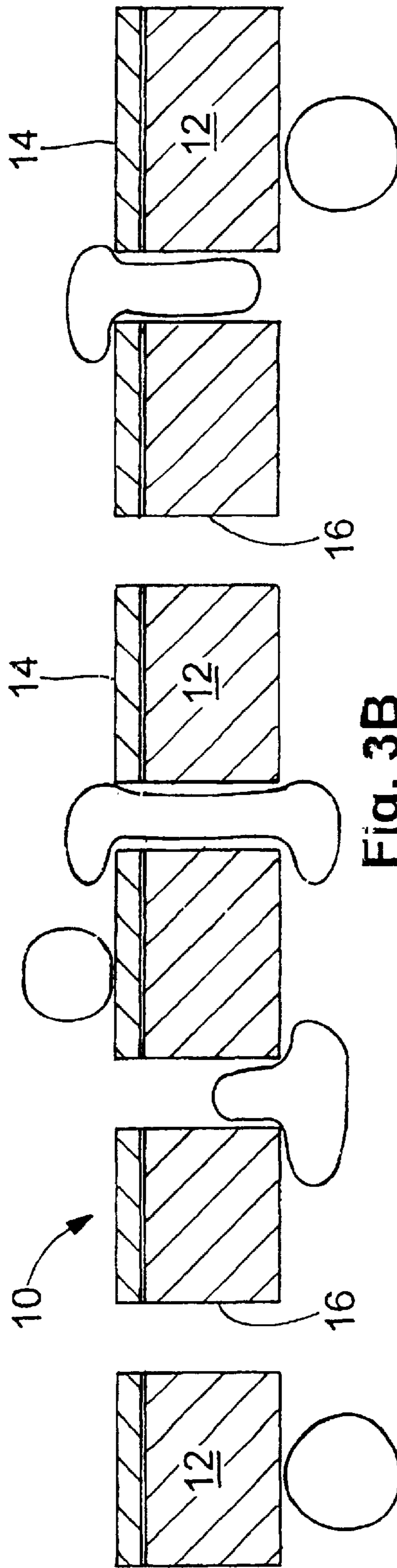

Fig. 3B

Fig. 4

HL-60/PMN CHEMOTAXIS to 10^{-8} M fMLP

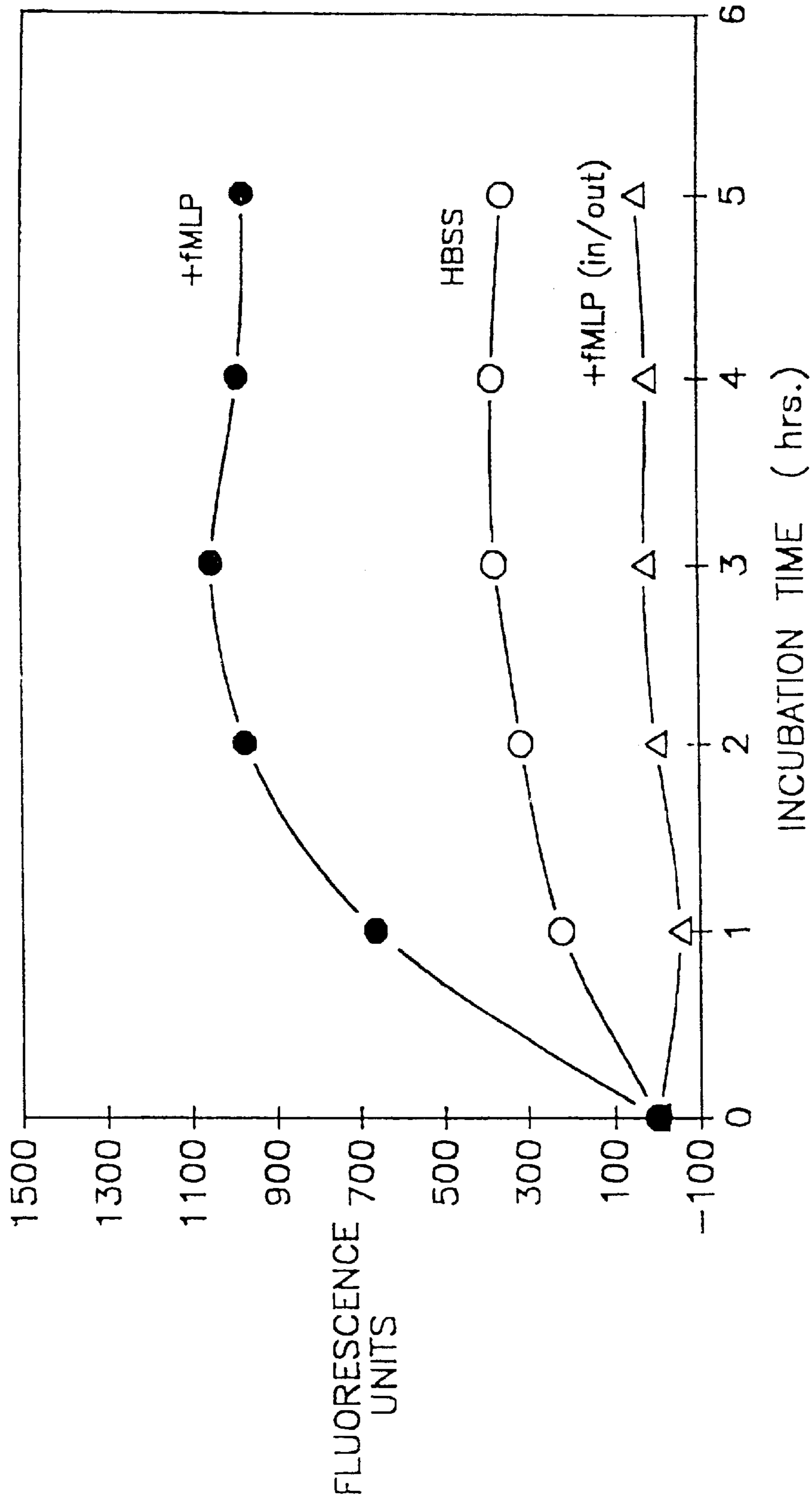

Fig. 5

HL-60/PMN CHEMOTAXIS to 10^{-8} M fMLP

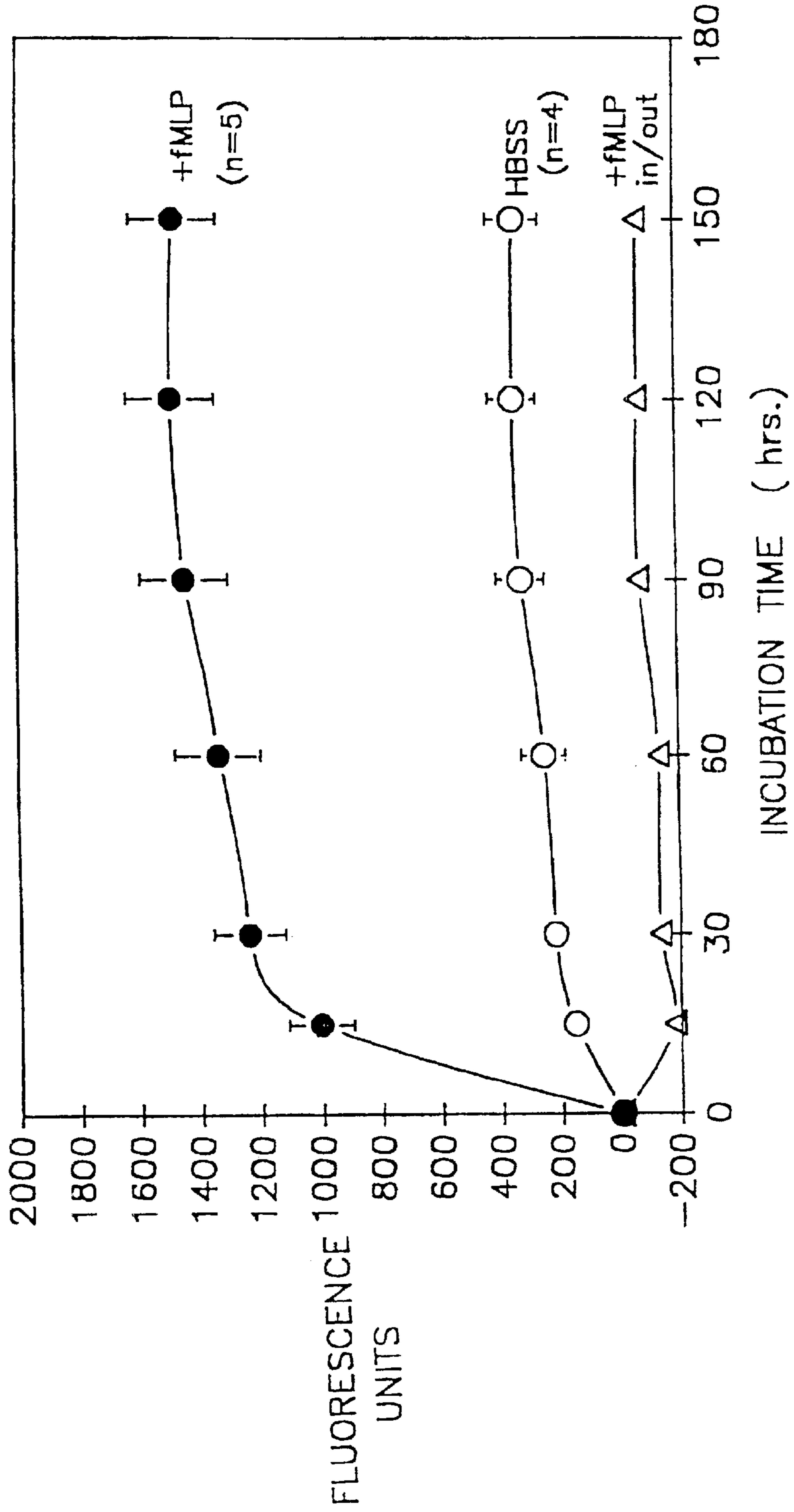

Fig. 6

HL-60/PMN CHEMOTAXIS to fMLP

"Fluorescence Opaque" Blue Membrane on Transwell-type inserts

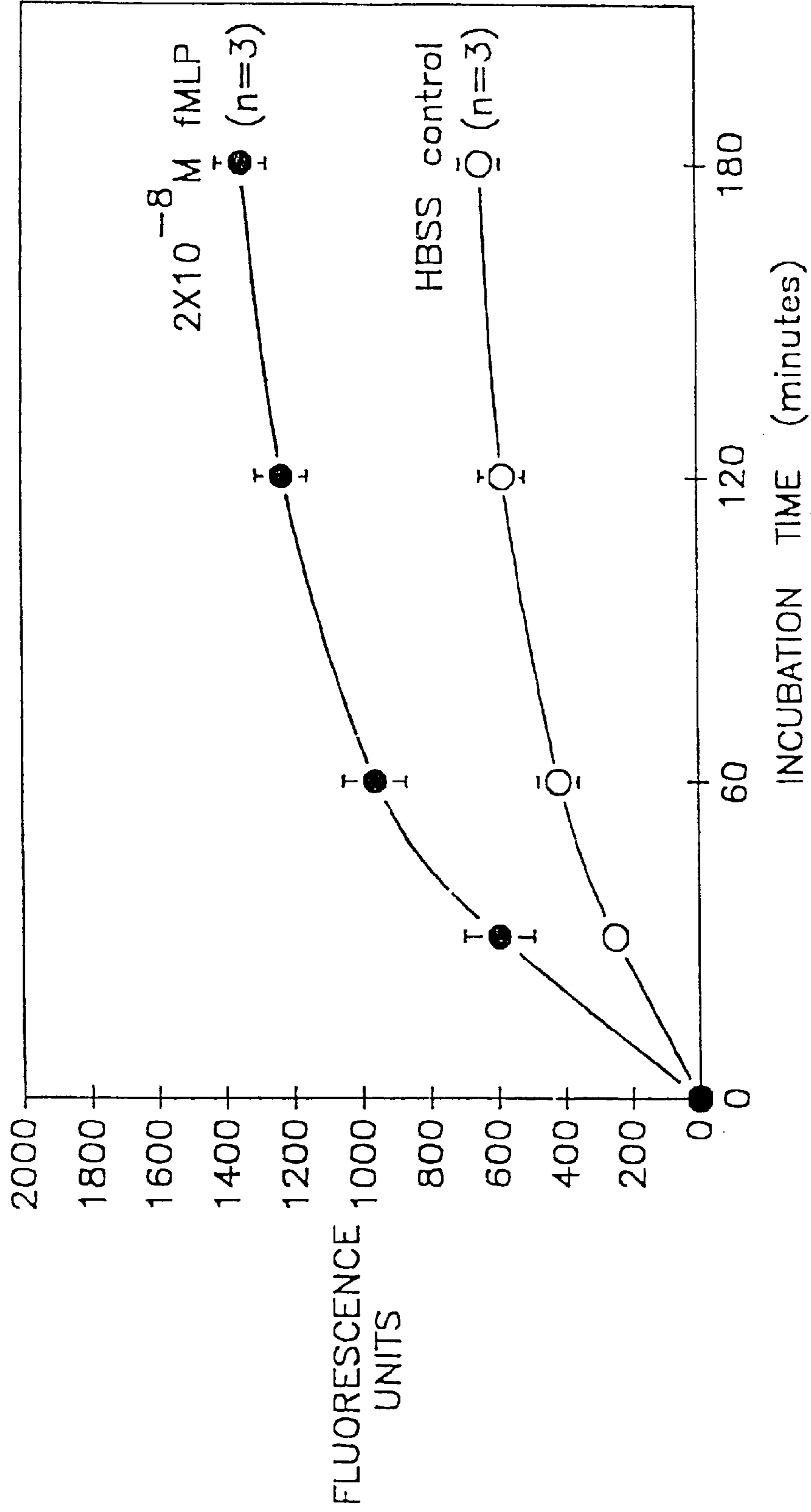
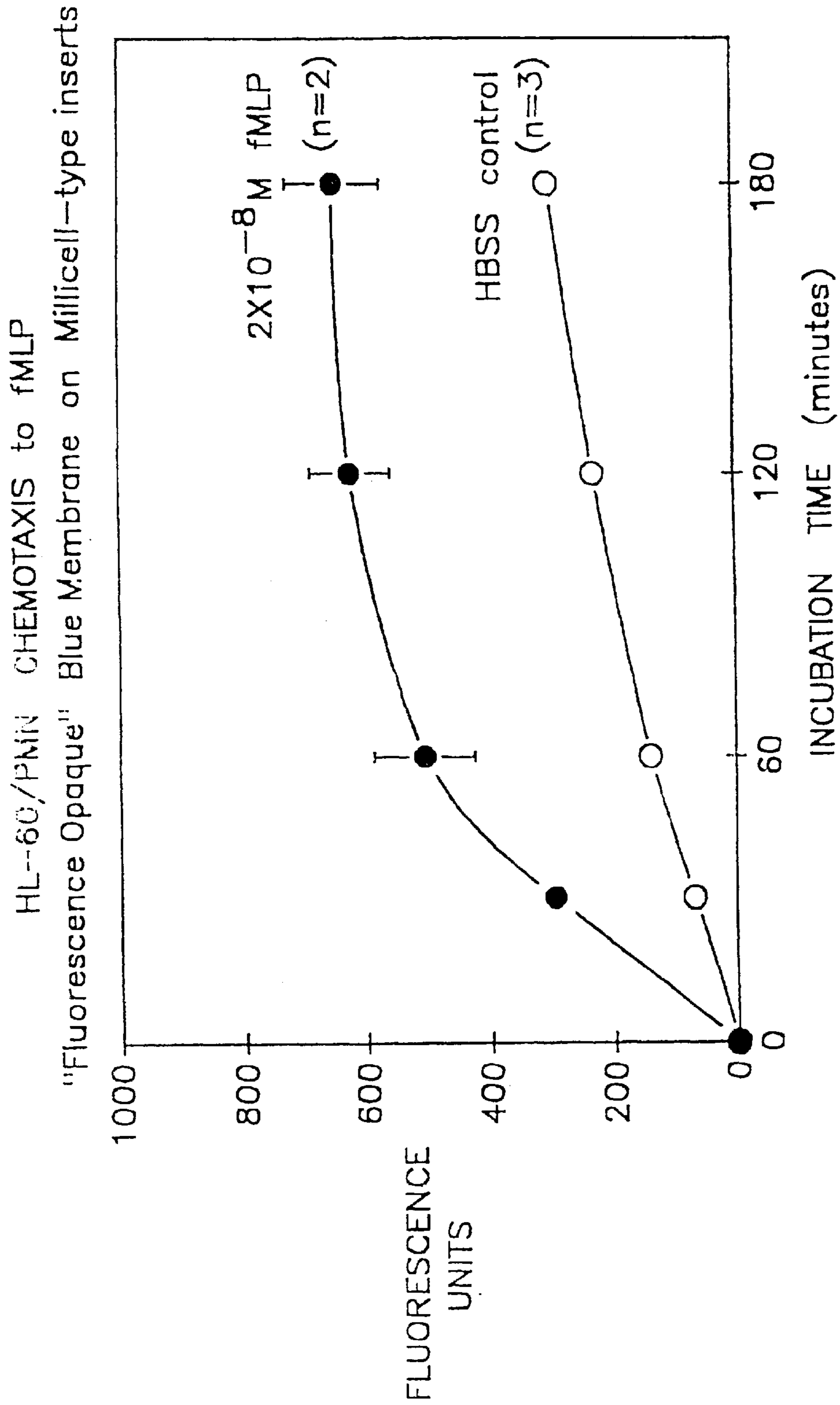

Fig. 7



CHEMOTAXIS ASSAY PROCEDURE

Matter enclosed in heavy brackets [] appears in the original patent but forms no part of this reissue specification; matter printed in italics indicates the additions made by reissue.

CROSS-REFERENCE TO RELATED APPLICATIONS

This application is a continuation of U.S. Ser. No. 09/472,490, filed Dec. 23, 1999, which is a reissue application Ser. No. 09/159,427 filed Sep. 23, 1998, now abandoned, which is a reissue of application Ser. No. 08/383,058 filed Feb. 3, 1995 U.S. Pat. No. 5,601,997.

FIELD OF THE INVENTION

This invention relates to a chemotaxis assay procedure and, more particularly, relates to an in vitro chemotaxis assay procedure which is non-destructive of the cell sample and permits kinetic study of the chemotactic response. This invention also relates to a novel radiation opaque membrane for use in the chemotaxis procedure.

BACKGROUND OF THE INVENTION

Chemotaxis is broadly defined as the orientation or movement of an organism or cell in relation to a chemical agent. Chemotaxis assays, particularly in vitro chemotaxis assays, are widely used procedures in medical, biological, pharmaceutical and toxicological research. Such assays are perhaps most widely used to determine the effect of a chemical agent on the inflammatory process, either as a stimulant or inhibitor of that process.

The currently used chemotaxis assay procedure derives from that originally developed by S. Boyden in 1962. (See, S. Boyden, *The Chemotactic Effect of Mixtures of Antibody and Antigen on Polymorphonuclear Leucocytes*, J. Exp. Med. 115: pp. 453-466, 1962). Essentially, the procedure involves placing a suspension of neutrophils and a chemical agent in two separate chambers, which chambers are separated by a polycarbonate filter. The neutrophils are typically either human polymorphonuclear neutrophils ("PMN's") prepared from the peripheral blood of volunteers or PMN's prepared from the peritoneal fluid of animals, such as guinea pigs or rabbits.

After a predetermined period of time, the filter is removed and cells on the filter surface closest to the chamber containing the cell suspension are carefully removed. The remaining cells on the filter are then fixed and stained. Using a high power microscope, the filter is examined and the number of cells appearing on the underside of the filter (i.e., the side of the filter closest to the chamber containing the chemical agent) are counted manually. A positive chemotactic response is indicated by the cells having migrated or "crawled" through the filter to the side closest to the chamber containing the chemical agent. Because of the time required to do so, typically the entire filter is not examined. Rather, representative sample areas are examined and counted.

There are several disadvantages to this procedure. The examination and counting of the cells on the filter is time-consuming, tedious and expensive. It is also highly subjective because it necessarily involves the exercise of judgment in determining whether to count a cell that has only partially migrated across the filter. In addition, the time and expense associated with examining the entire filter necessitates that

only representative areas, selected at random, be counted, thus rendering the results less accurate than would otherwise be the case if the entire filter were examined and counted.

Perhaps the most important disadvantage in this procedure is that the fixing step kills the cells. That is, the procedure is destructive of the cell sample. Thus, in order to determine a time-dependent relationship of the chemotactic response; that is, a kinetic study, of a particular chemical agent, it is necessary to run multiple samples for each of multiple time periods. When one considers that multiple samples, as well as positive and negative controls, are necessary to obtain reliable data, a single chemotaxis assay can produce dozens of filters, each of which needs to be individually examined and counted. The time and expense associated with a time-dependent study is usually prohibitive of conducting such a study using the Boyden procedure.

Alternatives to the Boyden assay have been proposed to overcome some of the above disadvantages. See generally, P. Wilkinson, *Micropore Filter Methods for Leukocyte Chemotaxis*, Methods in Enzymology, Vol. 162, (Academic Press, Inc. 1988), pp. 38-50. See also, Goodwin, U.S. Pat. No. 5,302,515; Guiruis et al., U.S. Pat. No. 4,912,057; Goodwin, U.S. Pat. No. 5,284,753; and Goodwin, U.S. Pat. No. 5,210,021. Although the chemotaxis devices and procedures described in these references have some advantages over the original Boyden procedure and apparatus, they are not without their shortcomings. For example, all of these procedures, like Boyden, require that the filter be removed and the non-migrated cells wiped or brushed from the filter before the migrated cells can be counted. In addition, most of these procedures require fixing and staining the cells and none of them permit the kinetic or time-dependent study of the chemotactic response of the same cell sample.

SUMMARY OF THE INVENTION

I have developed a chemotaxis assay procedure which avoids the above disadvantages, which is non-destructive, and which readily permits kinetic study of the chemotactic response. The chemotaxis procedure of this invention is simple, quick and inexpensive to perform, produces objective data, and is usable with a variety of different cell types.

Basically, the non-destructive chemotaxis assay procedure comprises the steps of:

- a) labeling cells with a dye;
- b) placing the labeled cells in a first chamber;
- c) placing a chemical agent in a second chamber adjacent to said first chamber;
- d) separating said first chamber from said second chamber with a radiation opaque membrane, said radiation opaque membrane having a plurality of substantially perpendicular transverse pores therein;
- e) stimulating the labeled cells on the side of the membrane closest to said second chamber with electromagnetic radiation of a first wavelength whereby said labeled cells will emit electromagnetic radiation of a second wavelength; and
- f) measuring the emitted electromagnetic radiation from the side of the radiation opaque membrane closest to the second chamber; wherein said radiation opaque membrane comprises a film which is not substantially transmissive to at least one of said first and second wavelengths of electromagnetic radiation.

In another aspect, the invention comprises a radiation opaque membrane for used in a chemotaxis assay procedure wherein cells labeled with a dye are stimulated with elec-

tromagnetic radiation of a first wavelength whereby the cells will emit electromagnetic radiation of a second wavelength, said radiation opaque membrane comprising a film which is not substantially transmissive to at least one of said first or second wavelengths of electromagnetic radiation, said radiation opaque membrane having a plurality of substantially perpendicular transverse pores therein.

These and other aspects of the invention will become apparent upon a reading of the following detailed description of the embodiments, with reference to the drawings, and the appended claims.

BRIEF DESCRIPTION OF THE DRAWINGS

FIG. 1 is a perspective view of a preferred apparatus used in carrying out the present procedure.

FIG. 2 is an enlarged, sectional view of the apparatus of FIG. 1 as seen along line 2—2 of FIG. 1.

FIG. 3A is a simplified schematic view, in cross-section, of cells migrating across one embodiment of the radiation opaque membrane of the present invention.

FIG. 3B is a simplified schematic view, in cross-section, of cells migrating across another embodiment of the radiation opaque membrane of the present invention.

FIGS. 4—7 are graphs of fluorescence units vs. incubation time of the chemotaxis data generated by the Examples.

DETAILED DESCRIPTION OF THE EMBODIMENTS

Although not critical to the present invention, a description of the preferred apparatus for use in carrying out the chemotaxis procedure of this invention is included because it is believed to be helpful in illustrating the advantages of this invention over the prior art. It is to be expressly understood, however, that any number of devices may be used in carrying out the present procedure and the invention is not limited to the use of any particular apparatus, except as set forth in the appended claims.

With reference first being made to FIGS. 1 and 2, the preferred apparatus comprises a multi-well culture plate which is widely available from a variety of commercial sources. This type of apparatus is commonly employed to study the effects of chemical agents on cell growth. As seen in FIGS. 1 and 2, the apparatus comprises a plate 20 having a plurality of spaced-apart wells 22. Each well 22 is provided with an insert 24 adapted to fit inside the well. In the parlance of this specification, the interior of the insert comprises one chamber and the exterior of the insert comprises a second chamber. The size, shape and number of wells 22, inserts 24, and plate 20 are not critical to this invention.

For purposes of this invention, the bottom of the insert 24 has been provided with a radiation opaque membrane 10 of this invention, which separates the two chambers. The radiation opaque membrane 10 may be attached to the bottom of the insert by any conventional means, such as glue or other adhesive, heat welding, ultrasonic welding, etc. In practice, the labeled cells are placed in the insert 24 and the chemical agent is placed in the well 22. The chemotactic reaction will cause the labeled cells to migrate or "crawl" from the chamber 24 to chamber 22, through the pores 16 in the radiation opaque membrane 10, as particularly shown in FIGS. 3A and 3B.

As seen in FIG. 2, a space 28 is created between the radiation opaque membrane 10 and the bottom of the well 22. A distance of about 1 mm between the bottom of well 22

and the radiation opaque membrane 10 is generally sufficient to permit the free migration of cells across the radiation opaque membrane. The space 28 may be conveniently created by providing the insert 24 with stand-offs 26, which may take any convenient form or shape (e.g. legs, bosses, flange, etc.). When using stand-offs, care should be taken not to isolate the fluid in space 28 from the remainder of the fluid in the well 22, which would tend to create a separate concentration gradient in the space 28. Alternatively, the space 28 may be created by suspending the insert 24 within the well 22 by the use of, for example, radial projections 27 which rest on the surface of plate 20 as shown in FIGS. 1 and 2.

At predetermined periods, the quantum of cells that have migrated across the radiation opaque membrane will be determined by first exciting or stimulating the labeled cells on the side of the radiation opaque membrane 10 closest to the chamber 22 and measuring the radiation emitted by those labeled cells. With the preferred apparatus illustrated in FIGS. 1 and 2, this step would comprise stimulating and measuring the radiation from below the radiation opaque membrane 10, that is, through space 28. It will be understood by those skilled in the art that it is preferred that at least the chamber through which the stimulation and measurement of radiation will take place is substantially transparent to both the radiation being measured and any radiation needed to excite or stimulate the dye used to label the cells. In the preferred embodiment, the apparatus is made of a clear, transparent material, such as polystyrene, polycarbonate, LUCITE®, glass, etc.

The device 30 used to stimulate the cells and measure the emitted radiation will, of course, depend on the dye used to label the cells and the type of apparatus used for the assay procedure. For example, if the plate apparatus of FIGS. 1 and 2 is used, a fluorescent plate reader, such as a Cytofluor™ 2300 (Millipore Corp., Marlborough, MA), can be used to advantage. The radiation opaque membrane 10 will substantially prevent either the stimulation of the cells in chamber 24 or the transmission of radiation from the cell sample in chamber 24 into the space 28, or will prevent both. Accordingly, the radiation measured will provide a direct quantitative measure of the number of cells that have migrated across the radiation opaque membrane 10 from chamber 24 to chamber 22.

It will be appreciated by those skilled in the art that neither insert 24, nor radiation opaque membrane 10, nor the non-migrated cells adhered to it, need be removed prior to measuring the radiation corresponding to the migrated cells. This permits repeated measurements of the chemotactic response of the same cell sample, thus permitting simple and rapid quantitative determinations in a kinetic, or time-dependent, profile of the chemotactic response with a minimum number of test samples. In addition, the devices used to measure the radiation, such as plate readers or spectrophotometers, are highly sensitive and accurate pieces of equipment and provide objective data corresponding to the number of migrated cells. This is a distinct advantage over the prior art procedures which rely upon subjective physical examination under a microscope.

As mentioned above, the chemotaxis assay of this invention can be used with a variety of cell types. Examples include, but are not limited to, macrophages, eosinophils, fibroblasts, endothelial cells, epithelial cells, PMN's, tumor cells and prokaryotic organisms. The only practical limitations on the cell type are its ability to exhibit a chemotactic response and its ability to be labeled.

In accordance with the present invention, the cell sample is labeled with a fluorescent dye. The process of labeling

cells with dyes is well known, as is the variety of fluorescent dyes that may be used for labeling particular cell types. See e.g. R. Haugland, Handbook of Fluorescent Probes and Research Chemicals, Molecular Probes, Inc. (1989). A particularly preferred fluorescent dye for use with an HL-60 cell line (ATCC No. CCL 240) in the present invention is Di-I (Molecular Probes, Inc.; Eugene, OR).

It should be mentioned here that, in theory, non-fluorescent dyes may be used in the present invention. At the present time however, there are no known devices that can be used to measure the transmitted light from migrated cells to the exclusion of the transmitted light from the non-migrated cells. Accordingly, the practical utility of using non-fluorescent dyes in the present invention awaits the discovery or invention of such a device.

A particularly novel aspect of the present invention is the use of a radiation opaque membrane which is not substantially transmissive to at least the wavelength of electromagnetic radiation used to stimulate the labeled cells or the wavelength of electromagnetic radiation emitted by the labeled cells. Preferably, the radiation opaque membrane is not substantially transmissive to both wavelengths of electromagnetic radiation, which would protect against excitation of non-migrated cells and would also prevent transmission of radiation emitted by any non-migrated cells that may, nevertheless, become stimulated. It may be advantageous in certain situations, such as for example where mixed cell types and multiple labeling dyes are used, to selectively block either the excitation wavelength or the emission Wavelength. Because the radiation opaque membrane is porous, it will be impossible to completely block all transmission of radiation across the radiation opaque membrane, simply because some radiation will be transmitted through the pores in the radiation opaque membrane. In practice, however, the quantum of radiation so transmitted will be relatively constant and negligible in terms of the quantum of radiation radiating from the migrated cells. Generally speaking, however, the radiation opaque membrane (absent any pores) should have a blocking efficiency of at least approximately 95%. That is, the membrane should be capable of blocking at least approximately 95% of the intended radiation, either the radiation used to stimulate the cells, the radiation emitted by the labeled cells, or the combined stimulation and emission radiation.

In accordance with the present invention, such membranes permit the measurement of radiation emitted from the labeled cells that have migrated through the radiation opaque membrane without interference from radiation emitted from the labeled cells that have not migrated, without the need to remove the non-migrated cells from the radiation opaque membrane. This is a significant advantage of the present invention over the prior art procedures, not only because it avoids the tedious steps of removing the filter and scraping the non-migrated cells from the filter, but also because it is non-destructive of the cell sample and thus permits repeated measurements of the same test sample at different time intervals.

The radiation opaque membrane itself may be of any convenient construction, so long as it has the properties mentioned above. In general, the radiation opaque membrane **10** comprises a non-fibrous film **12** of polyester, polycarbonate, polyethylene terephthalate, polylactic acid, nylon, etc. Depending on the type of film used, the film may be dyed to obtain the radiation blocking properties discussed above. In lieu of or in addition to using a dyed film, one or more radiation blocking layers **14** may be applied to the film by any conventional process suitable for the particular film

and blocking layer(s) being used, such as coating under vacuum, layer transfer, sputtering, spin coating, vacuum deposition, etc. The thickness of the radiation opaque membrane **10** is not critical to the invention. Membranes having a thickness in the range customarily used in the art are suitable for use herein.

As already noted, the radiation opaque membrane must have a plurality of pores **16** disposed substantially perpendicular to the plane of the radiation opaque membrane to permit the migration of cells across the radiation opaque membrane. The diameter of the pores is not particularly critical and, to a large extent, depends upon the size of the cells being studied. Generally speaking, the pores **16** must be of such diameter to prevent the cells from passively traversing the radiation opaque membrane while at the same permitting the cells to actively "crawl" through the radiation opaque membrane. It is readily within the skill of the ordinary artisan to determine the appropriate pore size for a particular chemotaxis assay without undue experimentation. Pores of suitable size can be provided in the film by any known process, such as atomic etching. If a radiation blocking layer(s) is to be applied to the film, it may be done either before or after the pores have been provided.

EXAMPLES

Cell Sample

The cell line HL-60 (ATCC No. CCL 240) was maintained in logarithmic growth phase as a suspension culture at about 10^6 cells/mL in RPMI 1640 medium (Mediatech Cellgrow, Fisher Scientific, Pittsburgh, PA.) supplemented with 20% (volume by volume) fetal bovine serum. (Hyclone Laboratories, Salt Lake City, UT). The cells were differentiated into mature myelocytes and neutrophils by incubating the cells for 48 hours at 37° C. in media containing 1.5% (volume by volume) dimethylsulfoxide.

Cell Labeling

Following the treatment with dimethylsulfoxide, the cells were incubated with 50 μ M Di-I fluorescent dye (Molecular Probes, Inc., Eugene, OR) at room temperature for 0.5–2 hours. The cells were then washed with Hanks' Balanced Salt Solution ("HBSS") (Sigma Chemical Co., St. Louis, MO.) and re-suspended in HBSS to achieve a cell concentration of 10^6 cells/mL. The fluorescence of 0.5 mL of cell suspension was measured in a Cytofluor™ 2300 fluorescent plate reader (Millipore Corp., Marlborough, MA.).

Membrane Preparation

Membrane 1: Polycarbonate film having a plurality of pores of 8 μ m diameter were coated with four molecular layers of carbon and one layer of an admixture of gold and palladium in a vacuum evaporator. The resulting radiation opaque membrane had a thickness of about 10 μ m and was approximately 97% efficient in blocking the combined stimulation and emission radiation. 6 mm disks of the radiation opaque membrane were glued to the bottom of inserts similar to the Millicell HA-12 mm (Millipore Corp.) or the Transwell-6.5 mm (Costar Corp., Cambridge, MA.) inserts with clear silicone rubber cement.

Membrane 2: A non-porous polyester film (18 μ m thick) containing a blue dye (Acquired Technology Inc., Alpharetta, GA.) was subjected to atomic etching to produce a 10 μ m thick radiation opaque membrane containing a plurality of pores of 8 μ m diameter having a combined radiation blocking efficiency of approximately 99%. 6 mm disks of the

radiation opaque membrane were glued to the bottoms of inserts as with membrane 1.

Test Procedure

Each insert equipped with the either membrane 1 or membrane 2 were placed in a well of a 24-well culture plate (Falcon, Fisher Scientific). 0.5 mL of labeled cell suspension was placed inside each insert. The plate was incubated for 30 minutes at 37° C. to allow the cells to settle on the radiation opaque membrane. The fluorescence of each well was then measured with the Cytofluor™ 2300 to obtain a zero time reading. 0.5 mL of either N-formyl methionyl leucyl phenylalanine ("f-MLP") (Sigma Chemical Co.) or HBBS was then added to each well. The fluorescence in each well was then measured at periodic time intervals using the Cytofluor™ 2300 at sensitivity setting 4. Results using membrane 1 are reported in Tables 1 and 2 and graphically illustrated in FIGS. 4 and 5. Results using membrane 2 are reported in Table 3 and graphically illustrated in FIGS. 6 and 7.

TABLE 1

Well Num- ber	Test Solutions insert/well	Fluorescence					
		0 hr.	1 hr.	2 hr.	3 hr.	4 hr.	5 hr.
1	HBSS/HBSS	546	757	862	922	927	904
2	HBSS/f-MLP ¹	383	1046	1355	1433	1370	1359
3	f-MLP ² /f-MLP	706	654	708	732	728	753
4	f-MLP ³ /f-MLP	467	412	435	460	447	454
5	Blank	130	124	125	125	125	125
6	Blank	132	127	127	128	127	126
7	Blank	131	127	127	128	127	126
8	Blank	128	124	126	125	127	125
9	Blank	129	125	126	126	126	125
10	Blank	130	127	127	127	128	127
11	Blank	135	133	132	132	132	132
12	Blank	130	126	125	126	125	125
13	Blank	132	128	129	130	129	128
14	Blank	134	141	136	139	136	137
15	Blank	137	134	133	134	134	132
16	Blank	136	131	132	133	132	132
17	Blank	135	134	132	134	131	132
18	Blank	137	132	131	132	132	133
19	Blank	136	132	131	132	132	133
20	Blank	139	135	132	135	134	135
21	Blank	141	135	136	138	136	137
22	Blank	140	137	137	138	136	137
23	0.5 mL cells	9999 ³	9999	9999	9999	9999	9999
24	0.5 mL cells	9999	9999	9999	9999	9999	9999

Notes:

¹Conc. = 10⁻⁷ M

²f-MLP added to cell suspension immediately before start of experiment.

³Fluorescence was greater than measurable at selected sensitivity setting.

TABLE 2

Well Num- ber	Test Solutions insert/well	FLUORESCENCE						
		0 min.	15 min.	30 min.	60 min.	90 min.	120 min.	150 min.
1	HBSS/f-MLP ¹	2927	4195	4475	4642	4761	4801	4788
2	HBSS/f-MLP	2895	4165	4400	4539	4642	4681	4655
3	HBSS/f-MLP	2631	3398	3584	3645	3728	3759	3728
4	HBSS/f-MLP	2594	3446	3707	3813	3932	3988	3999
5	HBSS/f-MLP	2515	3388	3594	3614	3717	3759	3770
6	f-MLP ² /f-MLP	2854	2675	2721	2721	2783	2783	2783
7	HBSS/HBSS	2558	2683	2736	2783	2862	2886	2911
8	HBSS/HBSS	2862	2977	3028	3053	3114	3132	3105
9	HBSS/HBSS	3105	3194	3221	3220	3294	3313	3294
10	HBSS/HBSS	2377	2660	2767	2846	2927	2952	2960
11	Blank	165	163	162	163	160	160	160

TABLE 2-continued

Well Num- ber	Test Solutions insert/well	FLUORESCENCE						
		0 min.	15 min.	30 min.	60 min.	90 min.	120 min.	150 min.
12	Blank	166	163	164	162	161	160	657
13	Blank	166	163	163	163	158	161	157
14	Blank	166	166	163	163	163	162	159
15	Blank	162	160	160	159	156	157	156
16	Blank	163	160	159	159	156	157	153
17	Blank	162	161	160	159	158	156	156
18	Blank	164	161	162	159	158	151	147
19	Blank	163	161	162	158	158	158	154
20	Blank	162	161	160	159	158	153	145
21	Blank	168	166	165	163	163	163	160
22	Blank	165	164	163	159	160	151	151
23	Blank	171	168	168	164	150	166	162
24	Blank	172	170	169	153	151	162	162

Notes:

¹Conc. = 10⁻⁸ M

²f-MLP added to cell suspension immediately before start of experiment

TABLE 3

Well Number	Test Solutions insert/well	Fluorescence				
		0 hr.	0.5 hr.	1 hr.	2 hr.	3 hr.
1	HBSS/HBSS ¹	1079	1378	1586	1770	1810
2	HBSS/HBSS	891	1058	1194	1351	1421
3	HBSS/HBSS	940	1221	1382	1533	1617
4	Blank	178	169	169	167	166
5	f-MLP ² /f-MLP	961	1245	1390	1564	1711
6	0.3 mL cells	9999	9999	9999	9999	9999
7	HBSS/f-MLP ³	1055	1770	2066	2351	2536
8	HBSS/f-MLP	1064	1454	1846	2143	2292
9	HBSS/f-MLP	1097	1775	2185	2411	2432
10	Blank	178	187	196	191	190
11	f-MLP/f-MLP	1049	1277	1413	1538	1582
12	0.3 mL cells	9999 ⁴	9999	9999	9999	9999
13	HBSS/HBSS ⁵	1425	1491	1577	1682	1735
14	HBSS/HBSS	1359	1454	1491	1551	1645
15	HBSS/HBSS	1340	1386	1478	1582	1650
16	Blank	179	172	176	178	171
17	f-MLP/f-MLP	1187	1181	1516	1622	1673
18	0.4 mL cells	9999	9999	9999	9999	9999
19	HBSS/f-MLP	1277	1573	1701	1836	1851
20	HBSS/f-MLP ⁶	1228	5928	6063	6342	6504
21	HBSS/f-MLP	1242	1207	1830	1931	1969
22	Blank	176	171	169	167	166
23	f-MLP/f-MLP	1231	1325	1454	1541	1604
24	0.4 mL cells	9999	9999	9999	9999	9999

Notes:

¹Transwell-type inserts used for wells 1-12.

²f-MLP added to cell suspension immediately before start of experiment.

³Conc. = 2 × 10⁻⁸ M

⁴Fluorescence greater than measurable at selected sensitivity setting.

⁵Millicell-type inserts used for wells 13-24.

⁶Insert leaked

What is claimed is:

1. A non-destructive chemotaxis assay procedure comprising the steps of:

- a) labeling cells with a fluorescent dye;
- b) placing the labeled cells in a first chamber;
- c) placing a chemical agent in a second chamber adjacent to said first chamber, said chemical agent being capable of inducing migration of said labeled cells from said first chamber to said second chamber;
- d) separating said first chamber from said second chamber with a radiation opaque membrane, said radiation opaque membrane having a plurality of substantially perpendicular transverse pores therein;

9

- e) stimulating the labeled cells on the side of the membrane closest to said second chamber with electromagnetic radiation of a first wavelength whereby said labeled cells will emit electromagnetic radiation of a second wavelength; and
- f) measuring the emitted electromagnetic radiation from the side of the radiation opaque membrane closest to the second chamber; wherein said radiation opaque membrane comprises a film which is not substantially transmissive to at least one of said first and second wavelengths of electromagnetic radiation.
2. The procedure of claim 1, wherein the fluorescent dye is Di-I.
3. The procedure of claim 3, wherein the radiation opaque membrane comprises a polyester film containing a blue dye.
4. The procedure of claim 1, wherein the radiation opaque membrane comprises a polycarbonate film coated with four layers of carbon and one layer of an admixture of gold and palladium.
5. The procedure of claim 1, wherein step (f) comprises measuring the electromagnetic radiation with a fluorescent plate reader.
6. The procedure of claim 1, further comprising the step of repeating steps (e) and (f) at least once at a predetermined time interval.
7. The procedure of claim 6, wherein the dye comprises a fluorescent dye.
8. The procedure of claim 7, wherein the fluorescent dye is Di-I.
9. The procedure of claim 8, wherein the radiation opaque membrane comprises a polyester film containing a blue dye.

10

10. The procedure of claim 8, wherein the radiation opaque membrane comprises a polycarbonate film coated with four layers of molecular carbon and one layer of an admixture of gold and palladium.
11. The procedure of claim 7, wherein the step (f) comprises measuring the electromagnetic radiation with a fluorescent plate reader.
12. The procedure of claim 6, wherein the film has a radiation blocking efficiency of at least approximately 95%.
13. The procedure of claim 1, wherein the film has a radiation blocking efficiency of at least approximately 95%.
14. The procedure of claim 13, wherein the film has a radiation blocking efficiency of at least approximately 97%.
15. A chemotaxis assay procedure comprising measuring the migration of cells across a radiation opaque membrane, wherein said procedure is non-destructive of said cells.
16. *A procedure of claim 15 when said cells are selected from the group consisting of macrophages, eosinophils, fibroblasts, endothelial cells, epithelial cells, PMN's, tumor cells and prokaryotic organisms.*
17. *A procedure of claim 15 including the step of inducing migration of said sample across said membrane.*
18. *A procedure of claim 17 including the step of providing a chemotactic agent on one side of said membrane.*
19. *A procedure of claim 18 including the steps of detecting sample presence on said one side of said membrane.*

* * * * *