



US00RE38708E

(19) **United States**  
(12) **Reissued Patent**  
**Bolanos et al.**

(10) **Patent Number: US RE38,708 E**  
(45) **Date of Reissued Patent: Mar. 1, 2005**

(54) **DISPOSABLE LOADING UNIT FOR SURGICAL STAPLER**

(75) Inventors: **Henry Bolanos**, Norwalk, CT (US);  
**Alli Alim**, Norwalk, CT (US); **Richard C. McClure**, Placentia, CA (US); **Keith L. Milliman**, Bethel, CT (US)

(73) Assignee: **United States Surgical Corporation**, Norwalk, CT (US)

(\*) Notice: This patent is subject to a terminal disclaimer.

(21) Appl. No.: **09/882,131**

(22) Filed: **Jun. 15, 2001**

**Related U.S. Patent Documents**

Reissue of:

(64) Patent No.: **5,911,353**  
Issued: **Jun. 15, 1999**  
Appl. No.: **09/044,041**  
Filed: **Mar. 18, 1998**

U.S. Applications:

(63) Continuation of application No. 08/501,197, filed on Jul. 11, 1995, now Pat. No. 5,752,644.

(51) **Int. Cl.<sup>7</sup>** ..... **A61B 17/068**  
(52) **U.S. Cl.** ..... **227/180.1; 227/19**  
(58) **Field of Search** ..... **227/180.1, 19, 227/175.1, 176.1**

(56) **References Cited**

**U.S. PATENT DOCUMENTS**

944,830 A 12/1909 Sussmann  
2,476,249 A 7/1949 Payne  
2,737,822 A 3/1956 Morse  
2,885,686 A 5/1959 Giaimo  
2,975,785 A 3/1961 Sheldon  
3,060,972 A 10/1962 Sheldon  
3,071,161 A 1/1963 Ulrich  
3,079,606 A 3/1963 Bobrov et al.  
3,090,378 A 5/1963 Sheldon

3,162,214 A 12/1964 Basinet  
3,190,286 A 6/1965 Stokes  
3,256,875 A 6/1966 Tsepelove et al.  
3,270,641 A 9/1966 Gosselin  
3,335,620 A 8/1967 Vertut  
3,490,675 A 1/1970 Green et al.  
3,499,591 A 3/1970 Green  
3,557,780 A 1/1971 Sato  
3,572,325 A 3/1971 Bazell et al.  
3,583,393 A 6/1971 Tahakashi  
3,587,872 A 6/1971 Pauly  
3,788,303 A 1/1974 Hall  
3,799,151 A 3/1974 Fukuami et al.  
3,892,228 A 7/1975 Mitsui  
3,998,216 A 12/1976 Hosono  
4,054,128 A 10/1977 Seufert et al.  
4,078,555 A 3/1978 Takahaski  
4,108,211 A 8/1978 Tanaka  
4,203,430 A 5/1980 Takahaski  
4,259,876 A 4/1981 Belyanin et al.  
4,273,111 A 6/1981 Tsukaya  
4,283,165 A 8/1981 Vertut  
4,290,421 A 9/1981 Siegmund  
4,347,837 A 9/1982 Hosono  
4,351,323 A 9/1982 Ouchi et al.  
4,429,695 A 2/1984 Green  
4,432,349 A 2/1984 Oshiro  
4,473,077 A 9/1984 Noiles et al.  
4,483,326 A 11/1984 Yamaka et al.  
4,494,417 A 1/1985 Larson et al.  
4,503,842 A 3/1985 Takayama  
4,557,254 A 12/1985 Yamaguchi  
4,593,679 A 6/1986 Collins  
4,606,343 A 8/1986 Conta et al.  
4,608,981 A 9/1986 Rothfuss et al.  
4,688,555 A 8/1987 Wardle  
4,700,693 A 10/1987 Lia et al.  
4,718,407 A 1/1988 Chikama  
4,721,099 A 1/1988 Chikama  
4,726,355 A 2/1988 Okada  
4,753,223 A 6/1988 Bremer  
4,754,909 A 7/1988 Barker et al.  
4,762,118 A 8/1988 Lia et al.  
4,762,119 A 8/1988 Allred, III et al.  
4,770,185 A 9/1988 Silverstein et al.  
4,773,395 A 9/1988 Suzuki et al.  
4,779,612 A 10/1988 Kishi  
4,787,369 A 11/1988 Allred, III et al.  
4,790,294 A 12/1988 Allred, III et al.

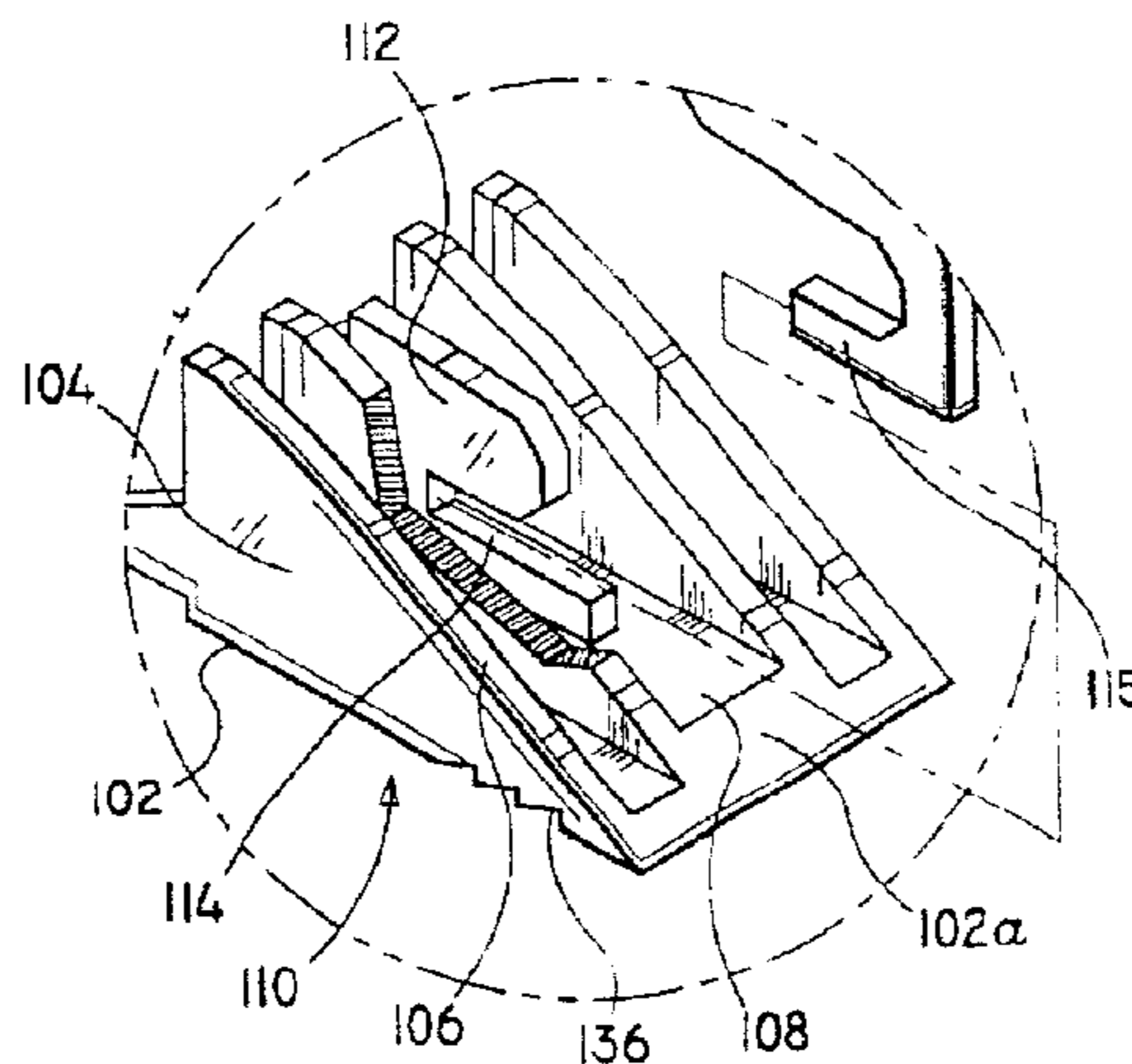

4,794,912 A	1/1989	Lia	
4,796,607 A	1/1989	Allred, III et al.	
4,805,596 A	2/1989	Hatori	
4,815,911 A	3/1989	Bengtson et al.	
4,834,069 A	5/1989	Umeda	
4,873,965 A	10/1989	Danieli	
4,905,666 A	3/1990	Fukuda	
4,911,148 A	3/1990	Sosnowski et al.	
4,919,112 A	4/1990	Siegmund	
4,947,827 A	8/1990	Opie et al.	
4,955,959 A	9/1990	Thompkins et al.	
4,977,790 A	12/1990	Nishi et al.	
4,996,974 A	3/1991	Ciarlei	
5,002,021 A	3/1991	Nakata et al.	
5,005,558 A	4/1991	Aomori	
5,007,406 A	4/1991	Takahaski et al.	
5,014,515 A	5/1991	Krauter	
5,014,685 A	5/1991	Takahashi	
5,025,804 A	6/1991	Kondo	
5,031,814 A	7/1991	Tompkins et al.	
5,040,715 A	8/1991	Green et al.	
5,042,707 A	8/1991	Taheri	
5,065,929 A	11/1991	Schulze et al.	
5,105,819 A	4/1992	Wollschlager et al.	
5,125,395 A	6/1992	Adair	
5,143,475 A	9/1992	Chikama	
5,156,315 A	10/1992	Green et al.	
5,158,086 A	10/1992	Brown et al.	
5,167,221 A	12/1992	Chikama	
5,168,864 A	12/1992	Shockey	
5,174,276 A	12/1992	Crockard	
5,174,277 A	12/1992	Matsumara	
5,176,126 A	1/1993	Chikama	
5,178,129 A	1/1993	Chikama	
5,179,935 A	1/1993	Miyagi	
5,195,968 A	3/1993	Lundquist et al.	
RE34,519 E	1/1994	Fox	
5,307,976 A	5/1994	Olson et al.	
5,312,003 A	5/1994	Domenig	
5,312,023 A *	5/1994	Green et al.	
5,318,221 A	6/1994	Green et al.	
5,326,013 A	7/1994	Green et al.	
5,332,142 A	7/1994	Robinson et al.	
5,391,180 A	2/1995	Tovey et al.	
5,394,864 A	3/1995	Kobayashi et al.	
5,411,519 A	5/1995	Tovey et al.	
5,417,203 A	5/1995	Tovey et al.	
5,447,265 A	9/1995	Vidal et al.	
5,478,003 A	12/1995	Green et al.	
5,485,947 A	1/1996	Olson et al.	
5,489,058 A	2/1996	Plyley et al.	
5,632,432 A	5/1997	Schulze et al.	
5,752,644 A *	5/1998	Bolanos et al. ....	227/180.1
5,911,353 A *	6/1999	Bolanos et al. ....	227/180.1

\* cited by examiner

Primary Examiner—Scott A. Smith

(57) ABSTRACT

A disposable loading unit is disclosed for use in conjunction with a surgical stapling apparatus configured to sequentially apply a plurality of surgical fasteners to body tissue. The apparatus includes an actuation assembly for effectuating a fastener applying operation, and a housing for receiving and releasably supporting the disposable loading unit. The disposable loading unit includes a staple cartridge body having a longitudinal pathway extending therethrough and a plurality of spaced apart retention slots defined therein each supporting a respective surgical fastener, a plurality of

fastener ejection members disposed adjacent the plurality of spaced apart retention slots and communicating with the longitudinal pathway, and an actuator supported within the staple cartridge body and configured to engage the actuation assembly of the apparatus and translate through the longitudinal pathway to contact the fastener ejection members and thereby sequentially eject the surgical fasteners from their respective retention slots.

U.S. PATENT DOCUMENTS

4,273,111	June 1981	Tsukaya.
4,283,165	August 1981	Vertut.
4,290,421	September 1981	Siegmund.
4,347,837	September 1982	Hosono.
4,351,323	September 1982	Ouchi et al..
4,429,695	February 1984	Green.
4,432,349	February 1984	Oshiro.
4,473,077	September 1984	Noiles et al..
4,483,326	November 1984	Yamaka et al..
4,494,417	January 1985	Larson et al..
4,503,842	March 1985	Takayama.
4,557,254	December 1985	Yamaguchi.
4,593,679	June 1986	Collins.
4,606,343	August 1986	Conta et al..
4,608,981	September 1986	Rothfuss et al..
4,688,555	August 1987	Wardle.
4,700,693	October 1987	Lia et al..
4,718,407	January 1988	Chikama.
4,721,099	January 1988	Chikama.
4,726,355	February 1988	Okada.
4,753,223	June 1988	Bremer.
4,754,909	July 1988	Barker et al..
4,762,118	August 1988	Lia et al..
4,762,119	August 1988	Allred, III et al..
4,770,185	September 1988	Silverstein et al..
4,773,395	September 1988	Suzuki et al..
4,779,612	October 1988	Kishi.
4,787,369	November 1988	Allred, III et al..
4,790,294	December 1988	Allred, III et al..
4,794,912	January 1989	Lia.
4,796,607	January 1989	Allred, III et al..
4,805,596	February 1989	Hatori.
4,815,911	March 1989	Bengtson et al..
4,834,069	May 1989	Umeda.
4,873,965	October 1989	Danieli.
4,905,666	March 1990	Fukuda.
4,911,148	March 1990	Sosnowski et al..
4,919,112	April 1990	Siegmund.
4,947,827	August 1990	Opie et al..
4,955,959	September 1990	Thompkins et al..
4,977,790	December 1990	Nishi et al..
4,996,974	March 1991	Ciarlei.
5,002,041	March 1991	Chikama.
5,005,558	April 1991	Aomori.
5,007,406	April 1991	Takahasi et al..
5,014,515	May 1991	Krauter.
5,014,685	May 1991	Takahashi.
5,025,804	June 1991	Kondo.
5,031,814	July 1991	Tompkins et al..
5,042,707	August 1991	Taheri.
5,065,929	November 1991	Schulze et al..
5,108,819	April 1992	Wollschager et al..
5,125,395	June 1992	Adair.
5,143,475	September 1992	Chikama.
5,156,315	October 1992	Green et al..
5,158,086	October 1992	Brown et al..
5,167,221	December 1992	Chikama.
5,168,864	December 1992	Shockey.
5,174,276	December 1992	Crockard.
5,174,277	December 1992	Matsumaru.
5,176,126	January 1993	Chikama.
5,178,129	January 1993	Chikama.
5,179,935	January 1993	Miyagi.
5,195,968	March 1993	Lundquist et al..

# US RE38,708 E

Page 3

-continued

---

U.S. PATENT DOCUMENTS

---

5,307,976	May 1994	Olson et al..
5,312,023	May 1994	Green et al..
5,318,221	June 1994	Green et al..
5,326,013	July 1994	Green et al..
5,332,142	July 1994	Robinson et al..
5,391,180	February 1995	Tovey et al..
5,394,864	March 1995	Kobayashi et al..
5,411,519	May 1995	Tovey et al..
5,417,203	May 1995	Tovey et al..
5,447,265	September 1995	Vidol et al..

-continued

---

U.S. PATENT DOCUMENTS

---

5,478,003	December 1995	Green et al..
5,485,947	January 1996	Olson et al..
5,489,058	February 1996	Plyley et al..
5,632,432	May 1997	Schulze et al.. 227/180.1
B1 5,040,715	August 1991	Green et al..

---

**11 Claims, 16 Drawing Sheets**

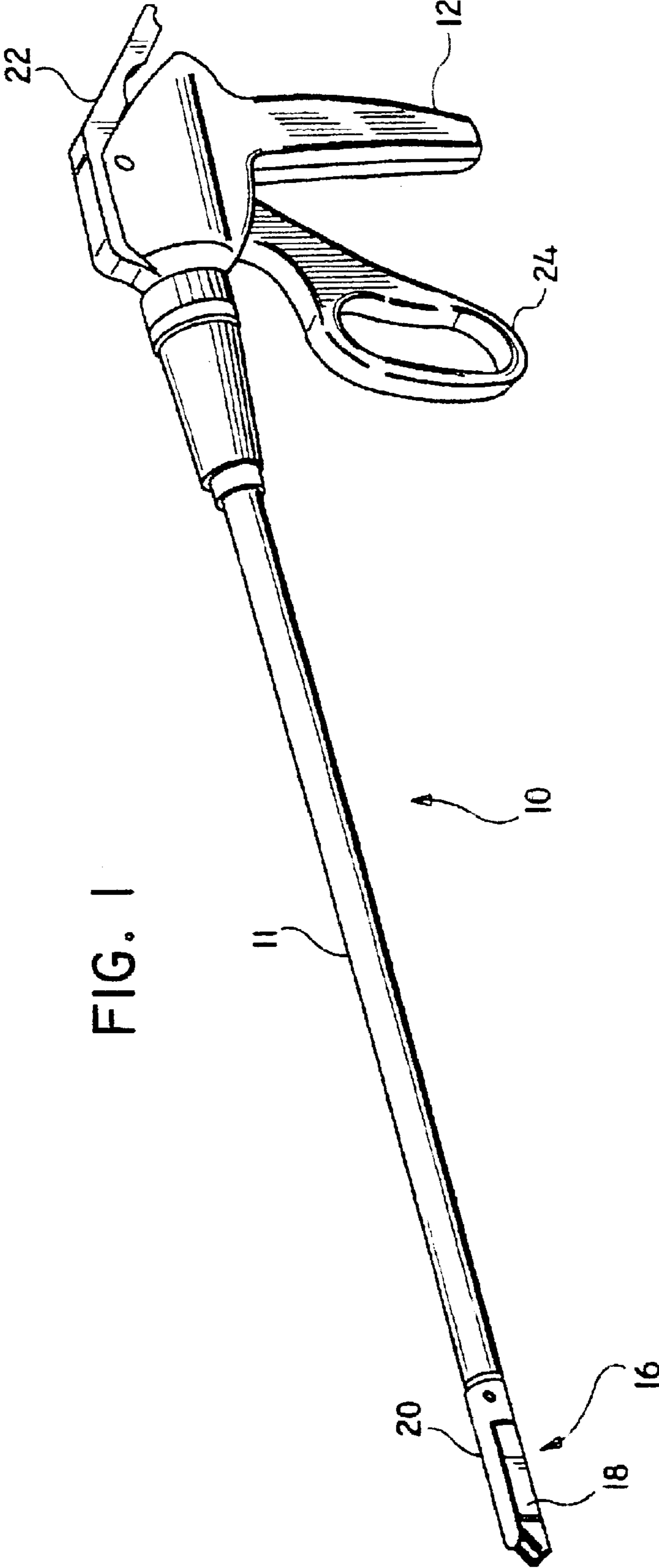

FIG. 1

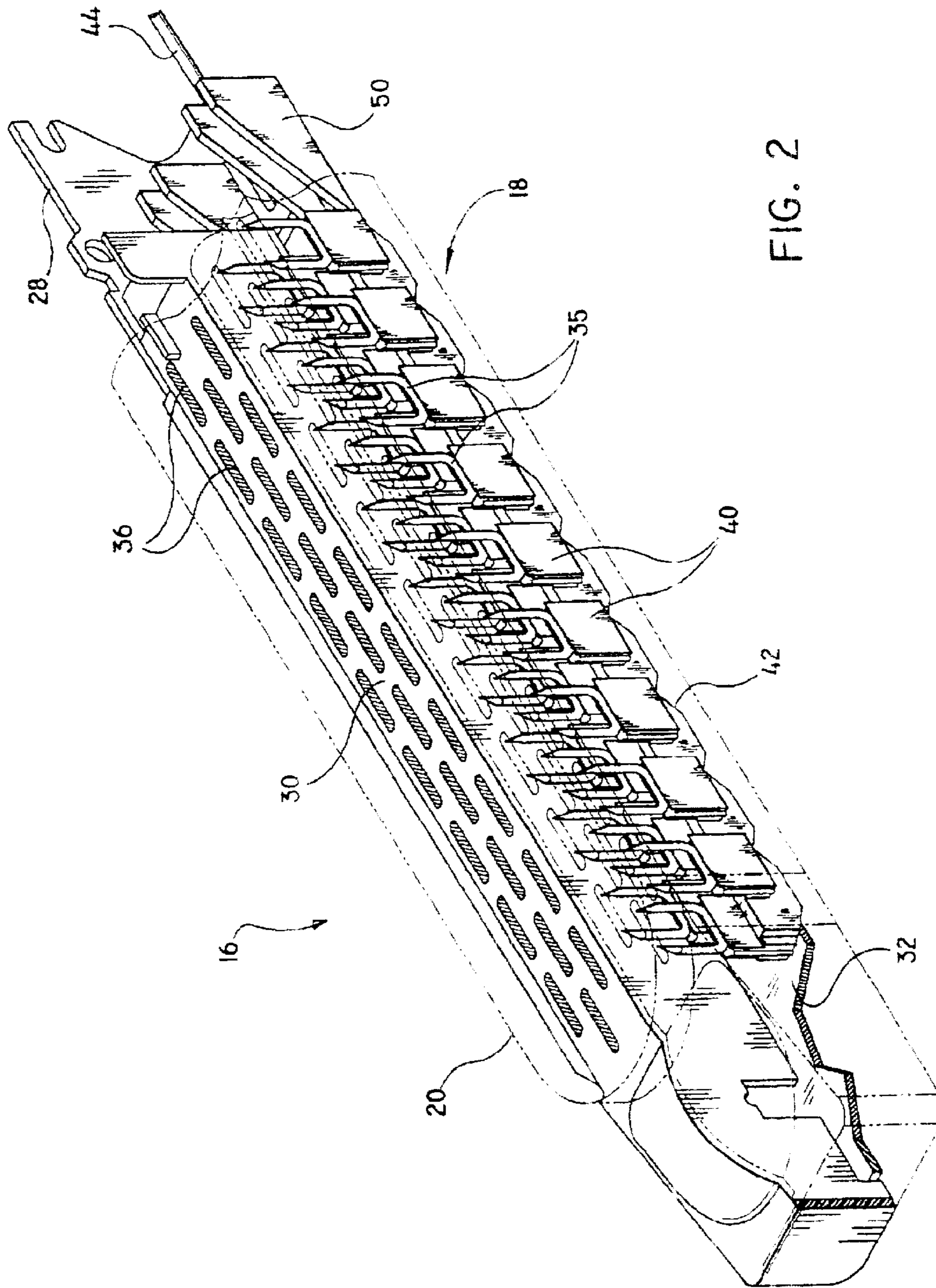

FIG. 2

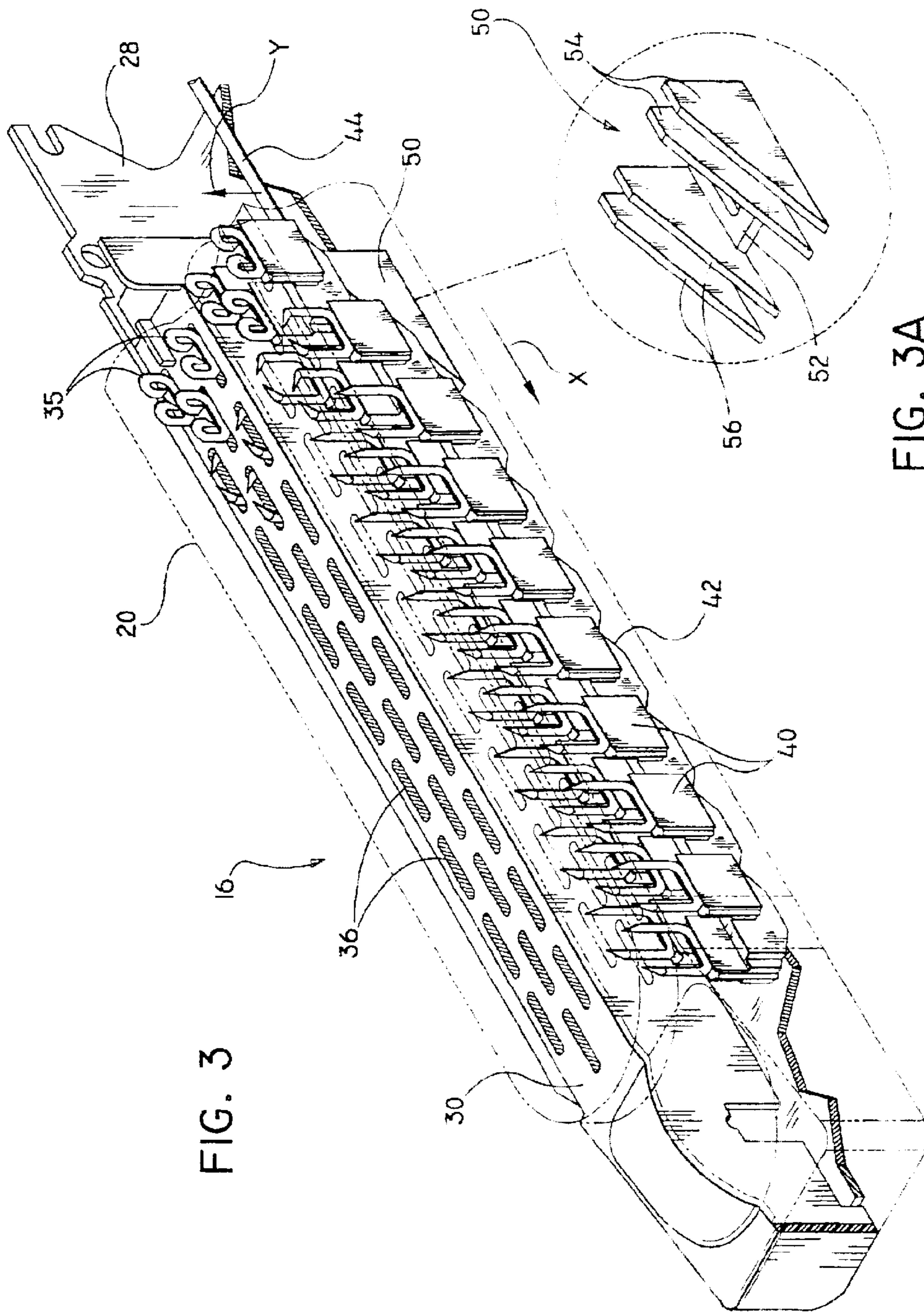

FIG. 3

FIG. 3A

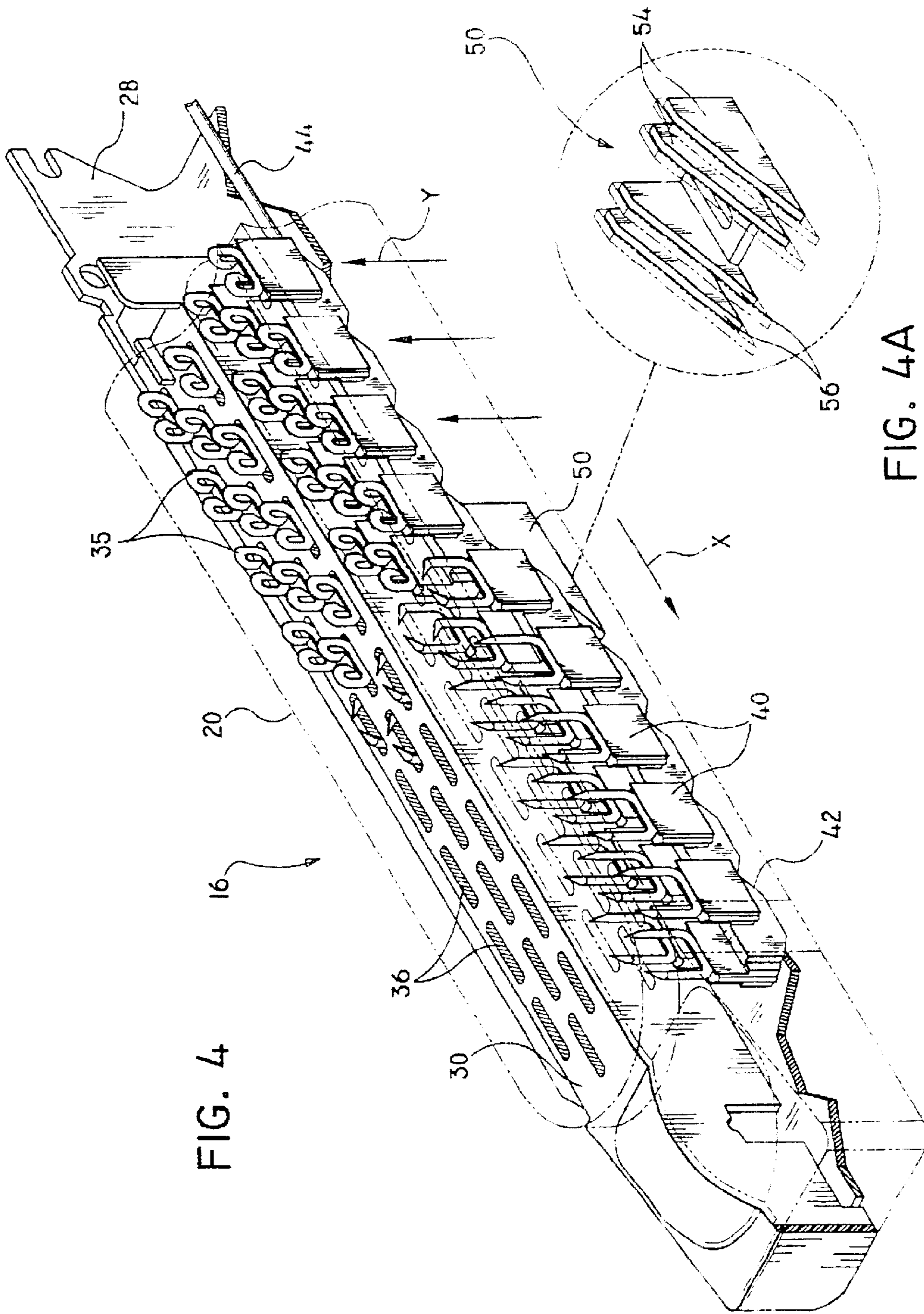

FIG. 4

FIG. 4A

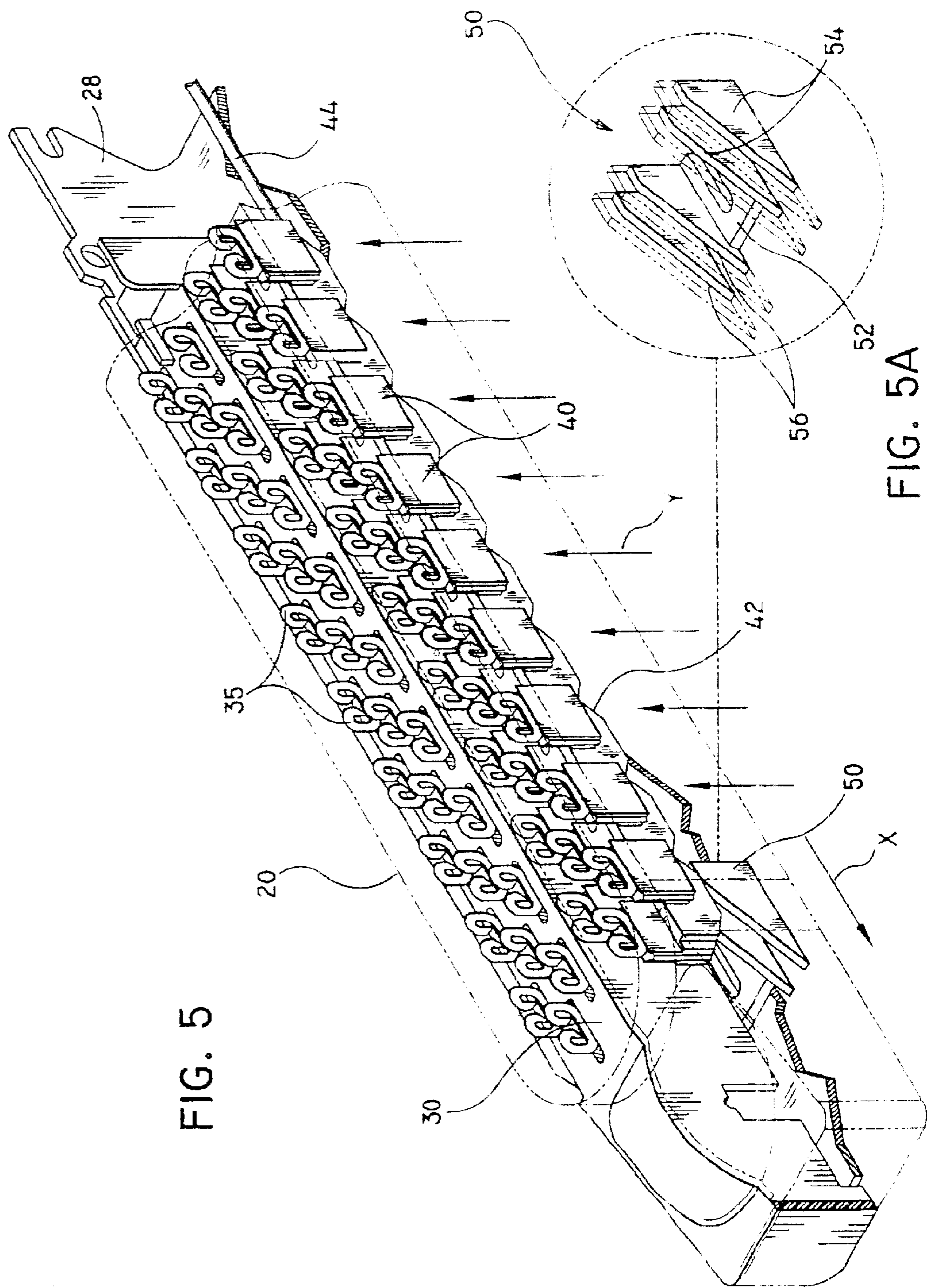

FIG. 5

FIG. 5A



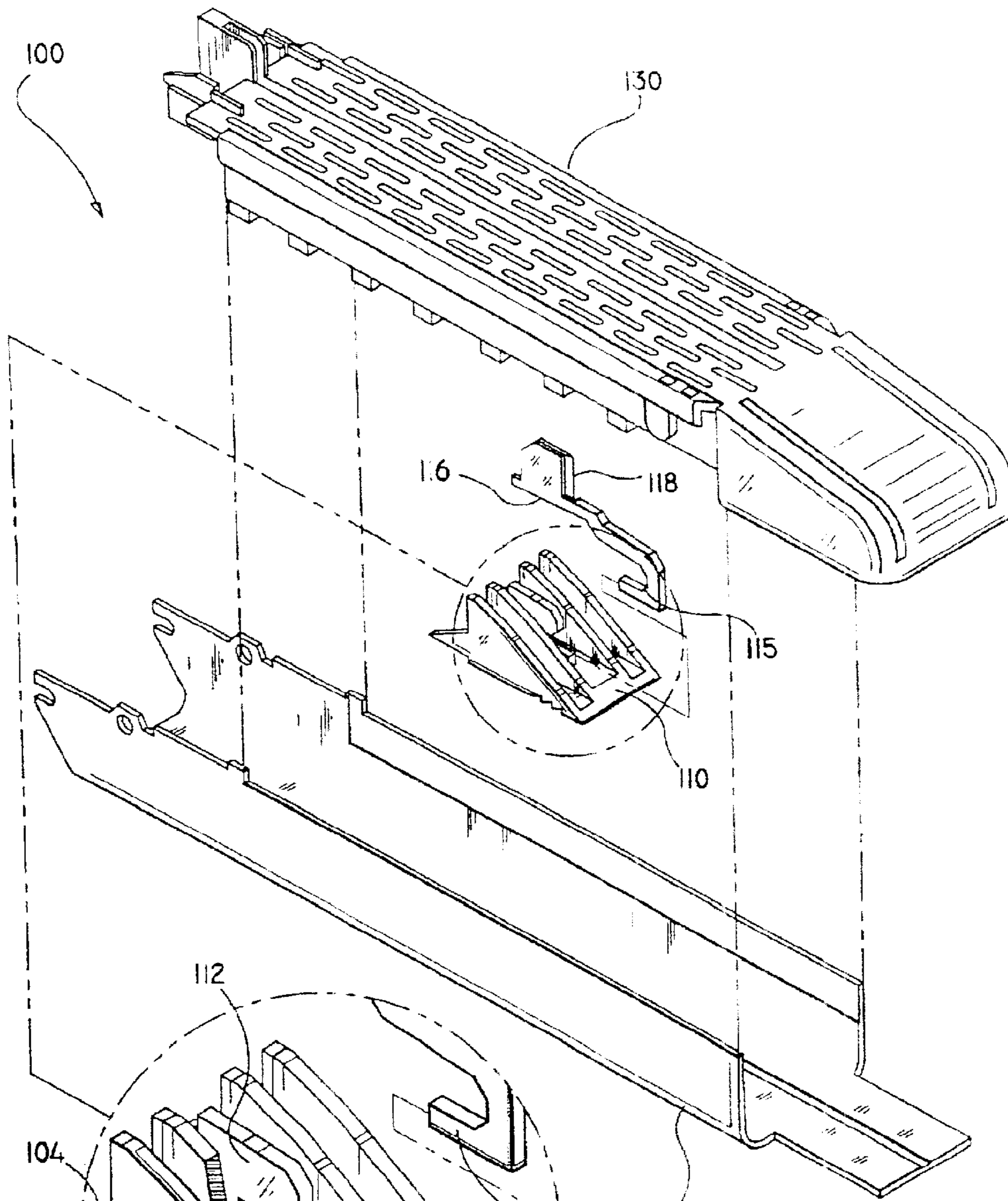

FIG. 6

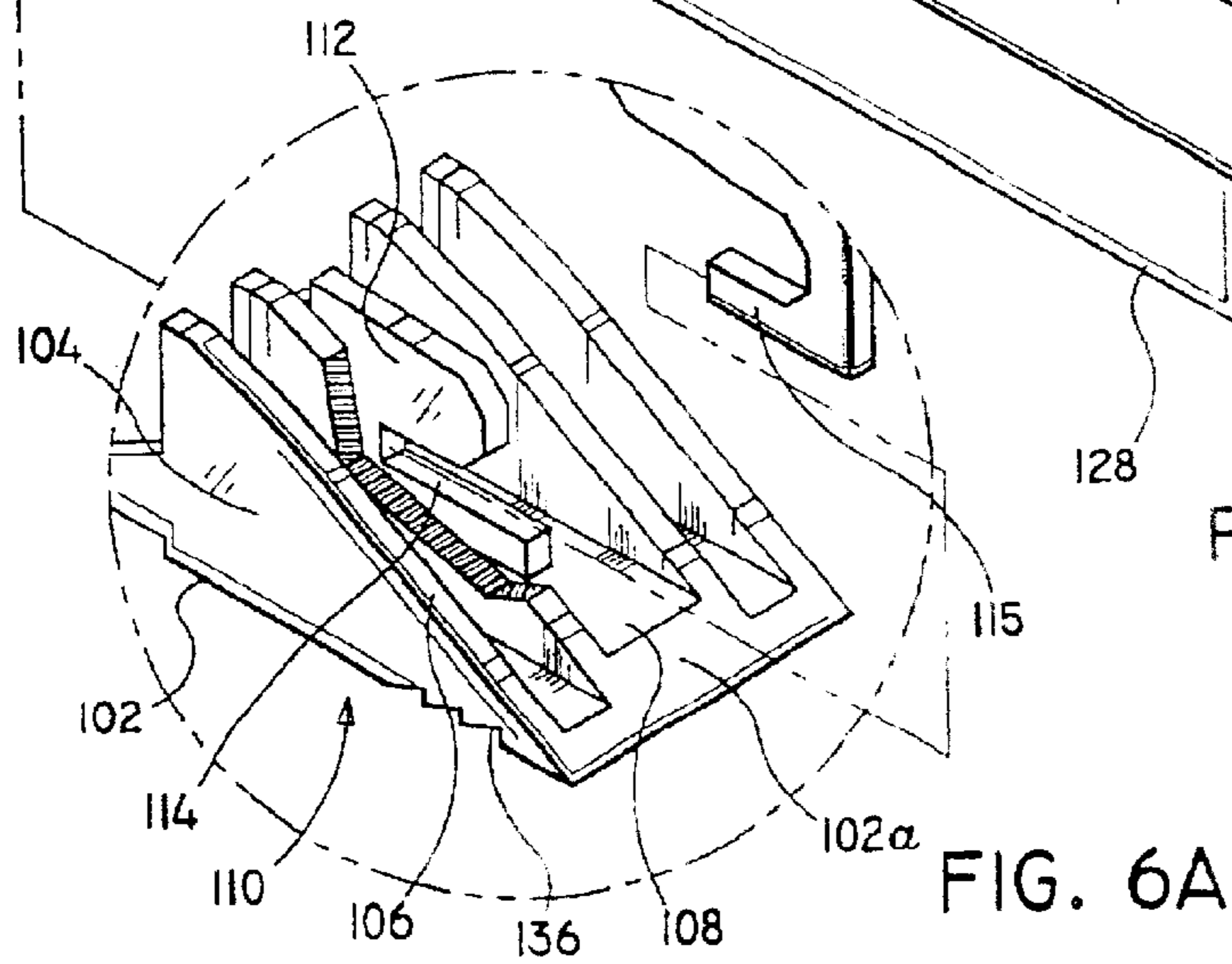
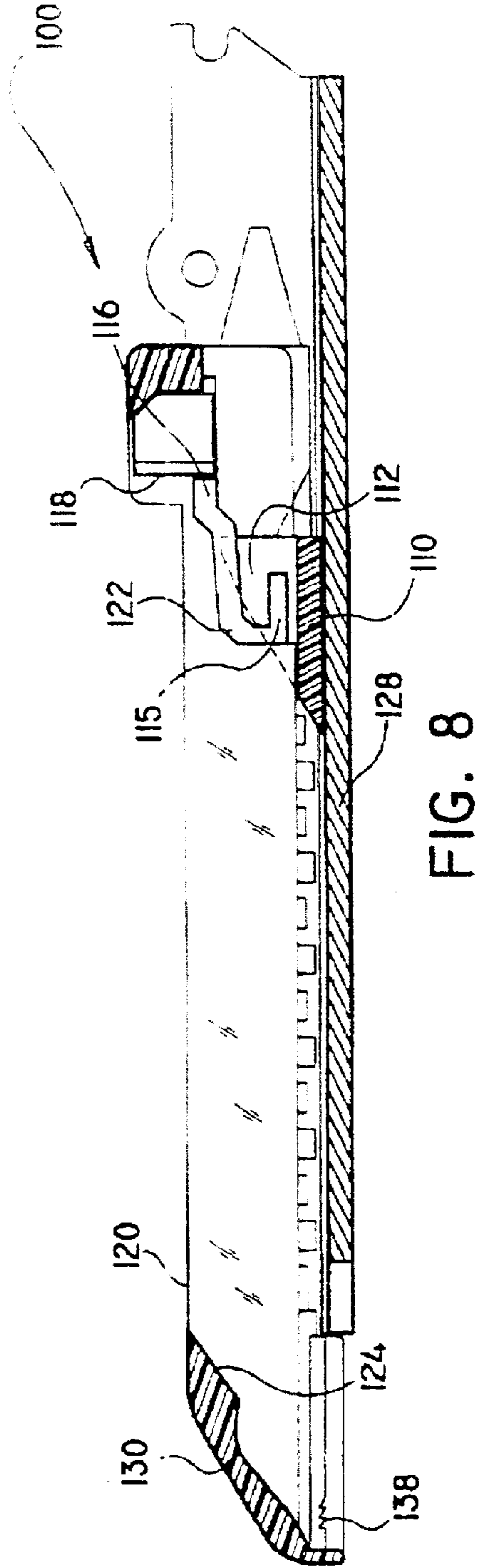
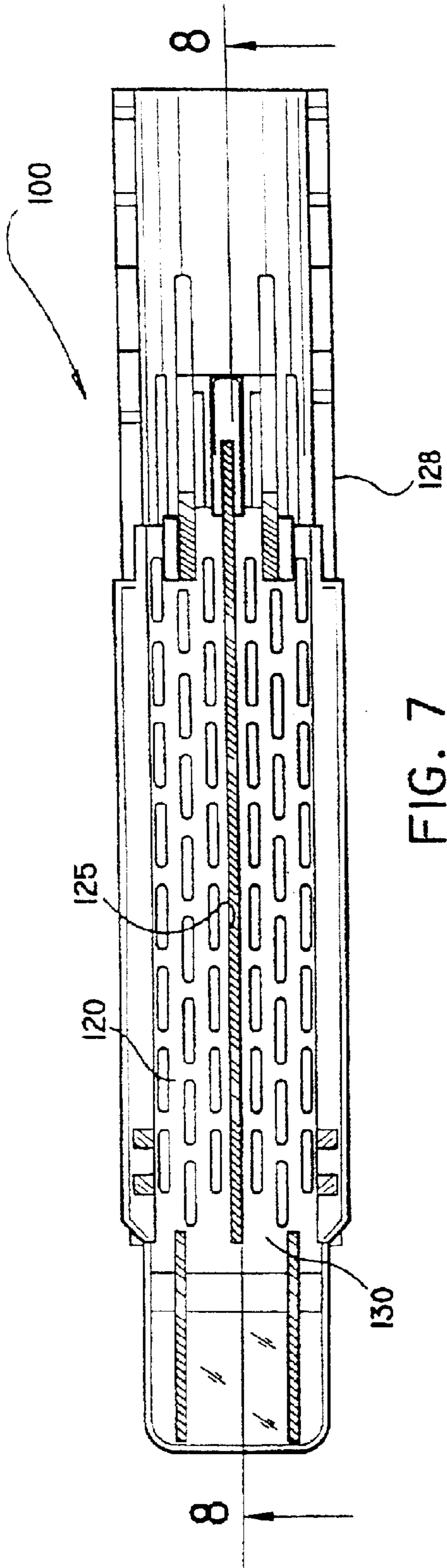

FIG. 6A



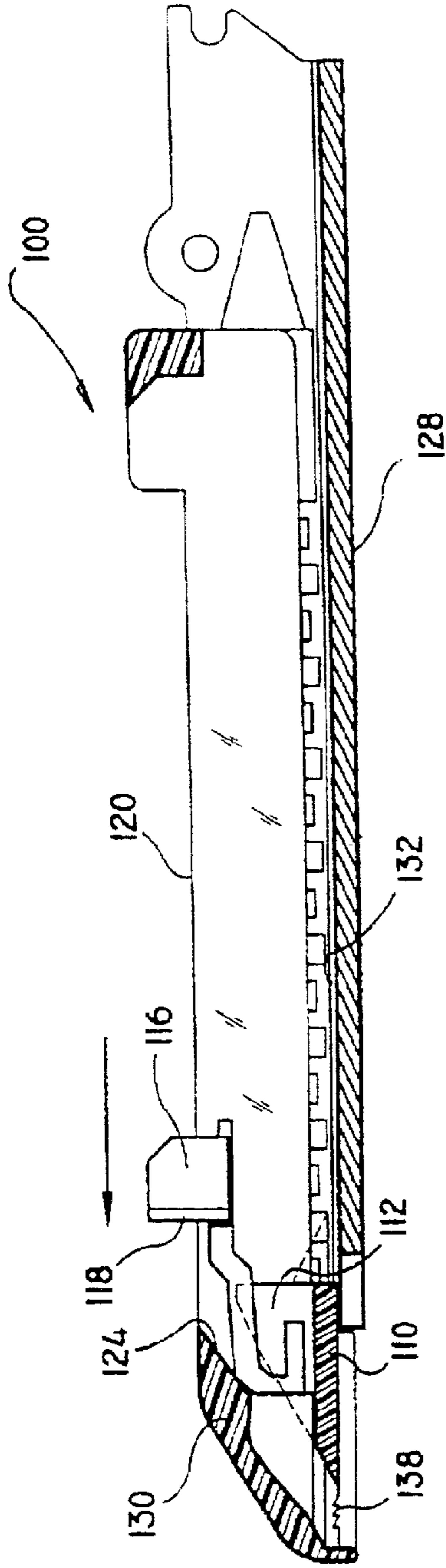

FIG. 9

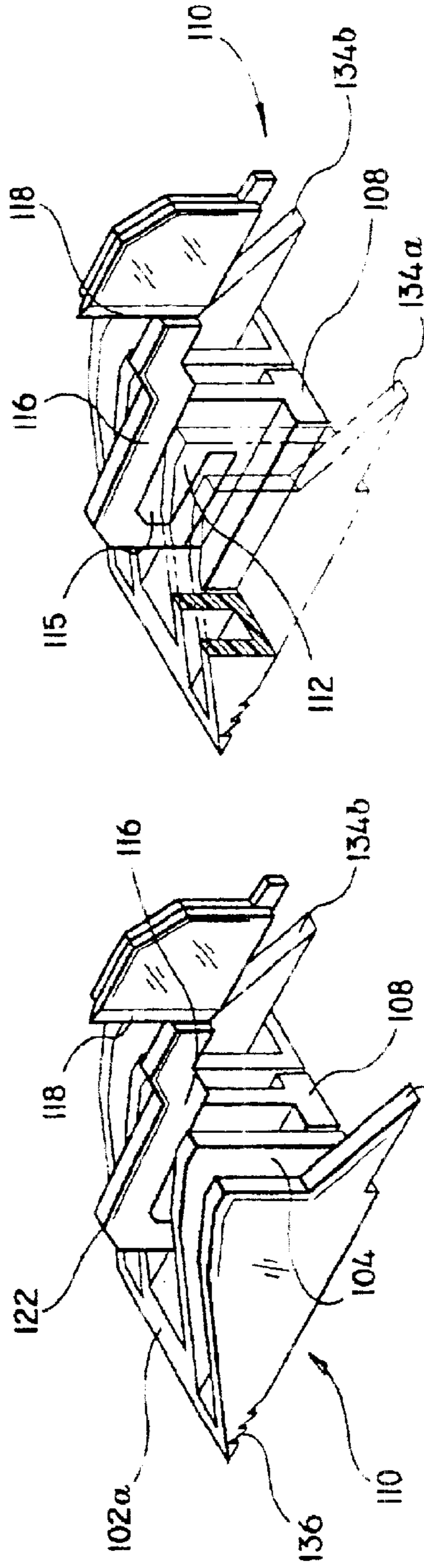

FIG. 10B

FIG. 10A

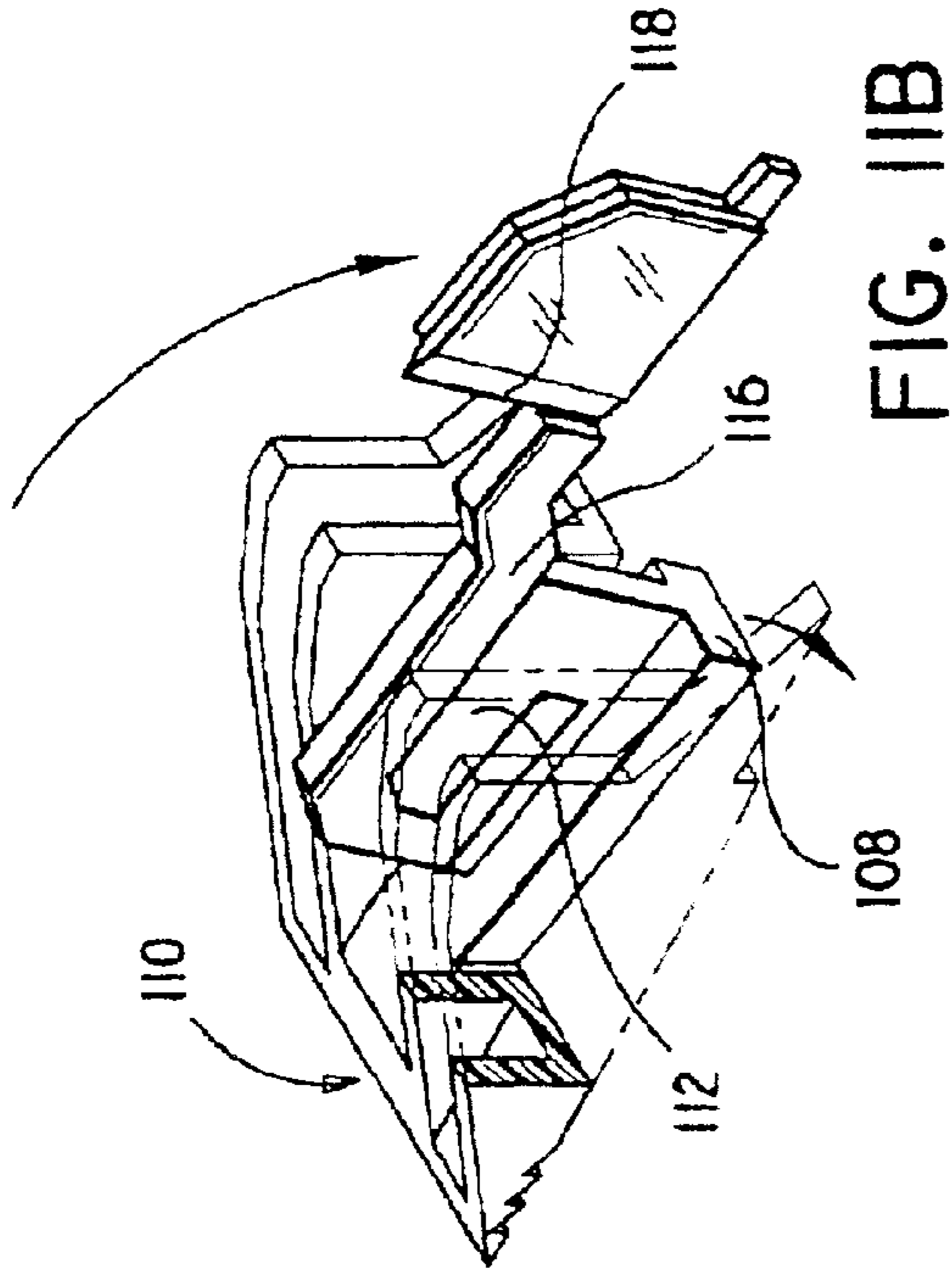

FIG. 11B

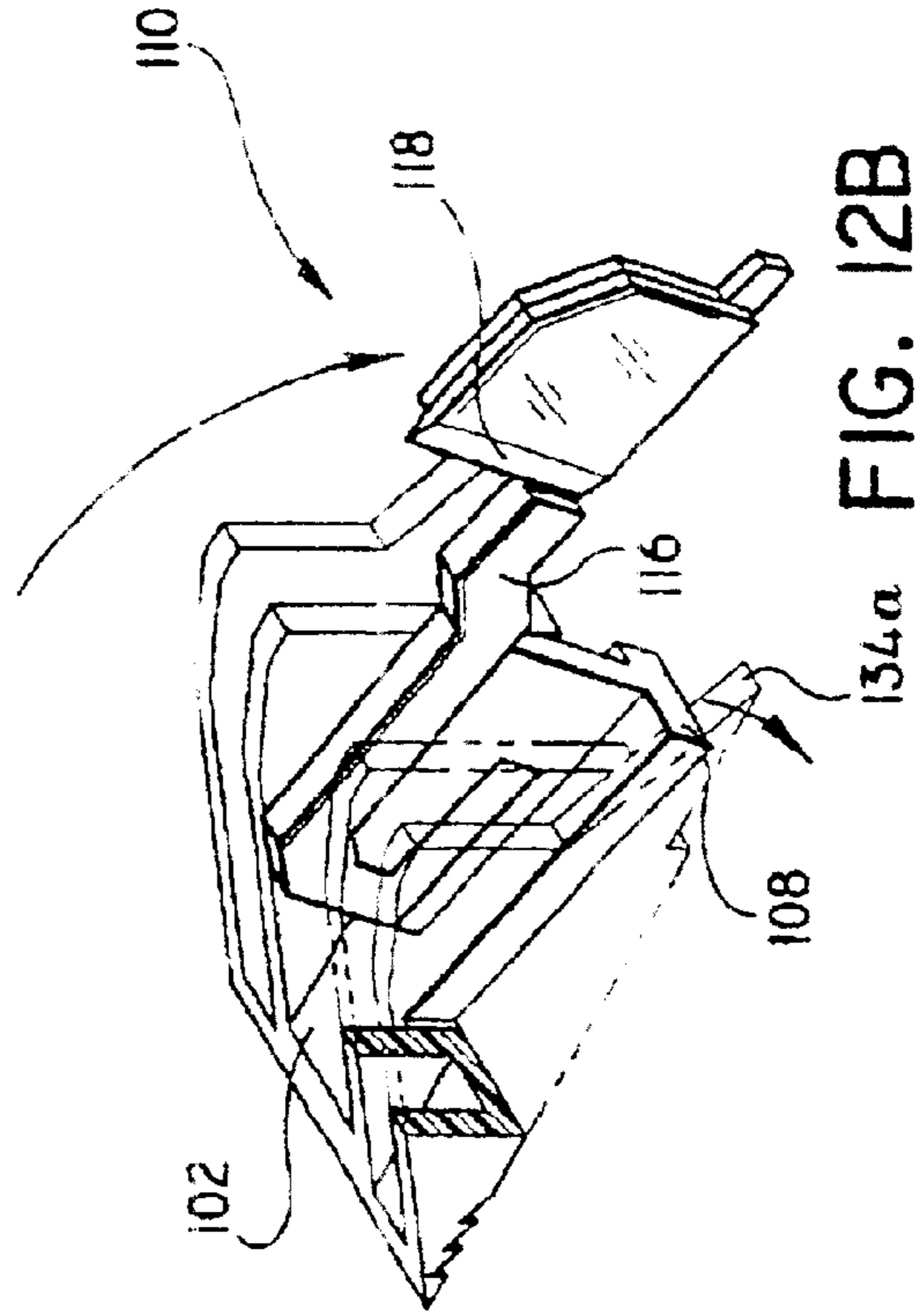

FIG. 12B

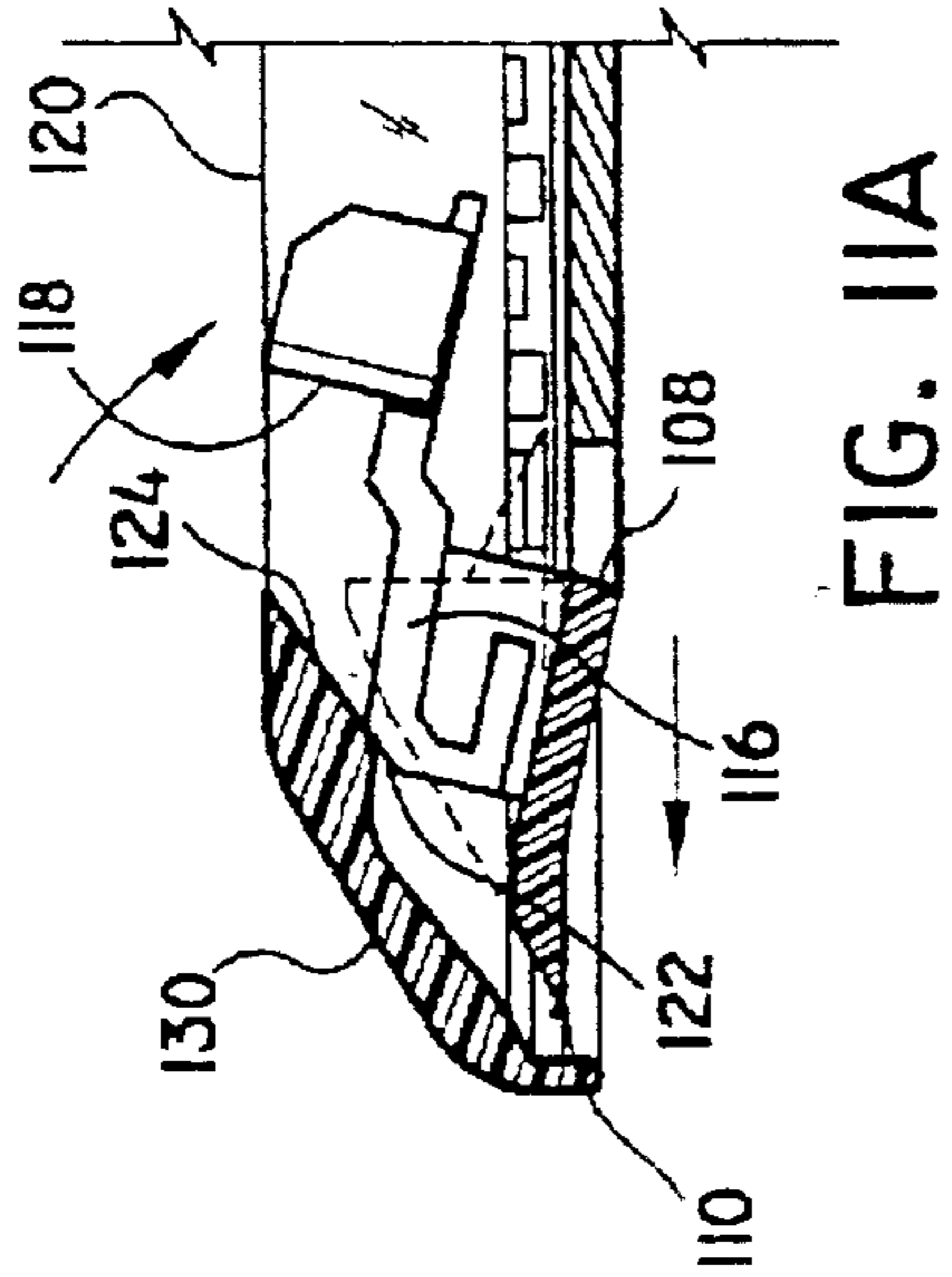

FIG. 11A

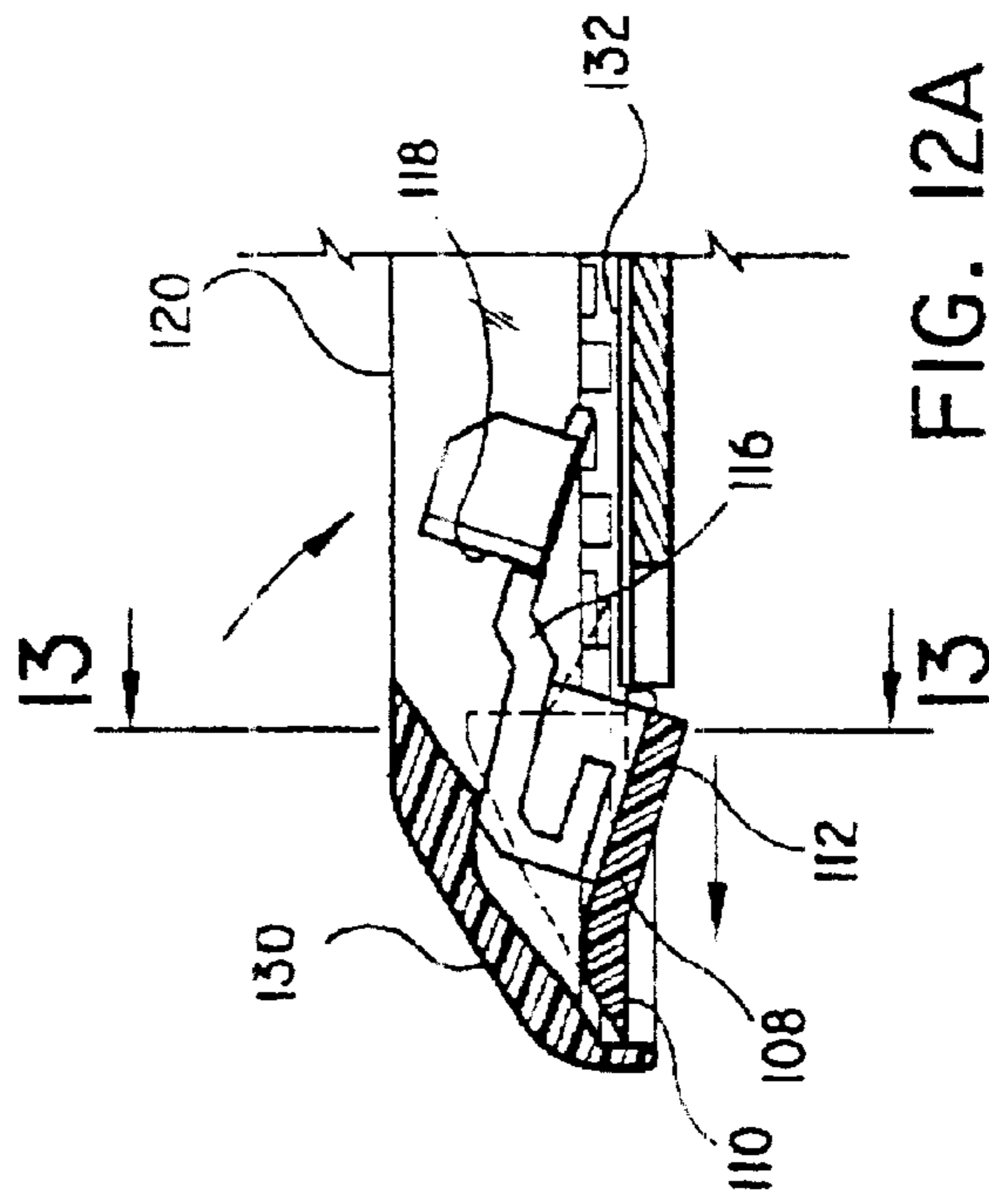

FIG. 12A

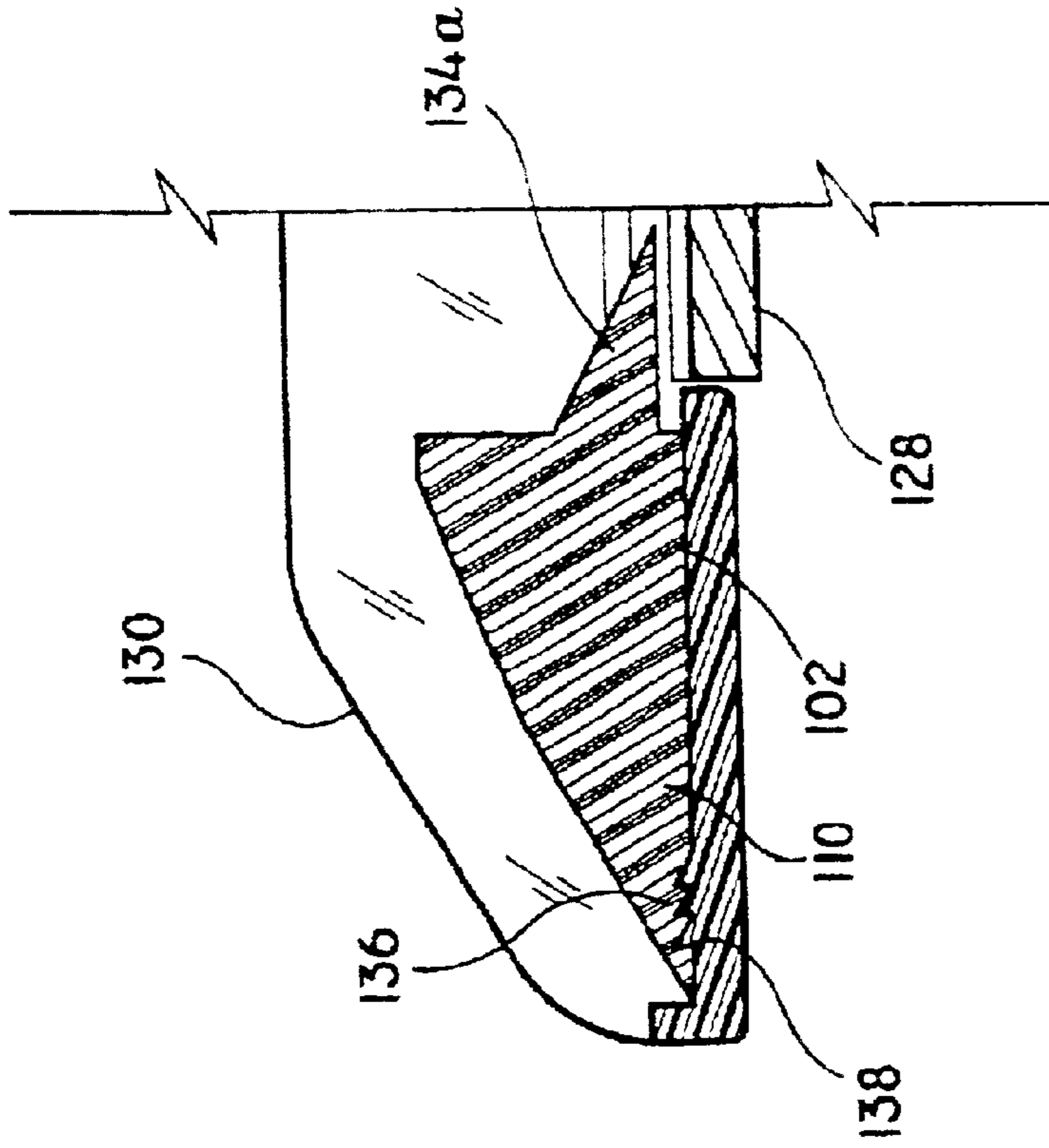

FIG. 13

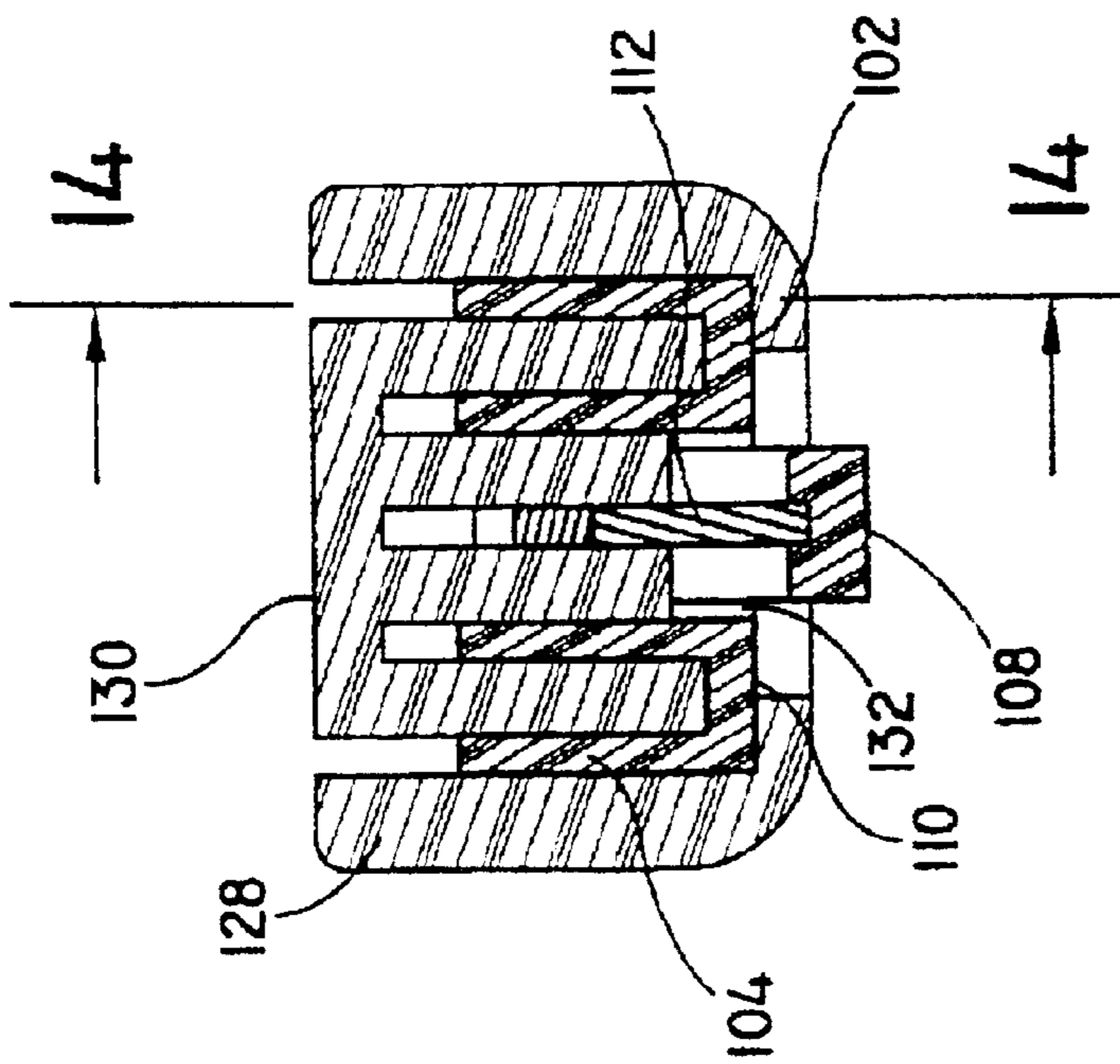

FIG. 14

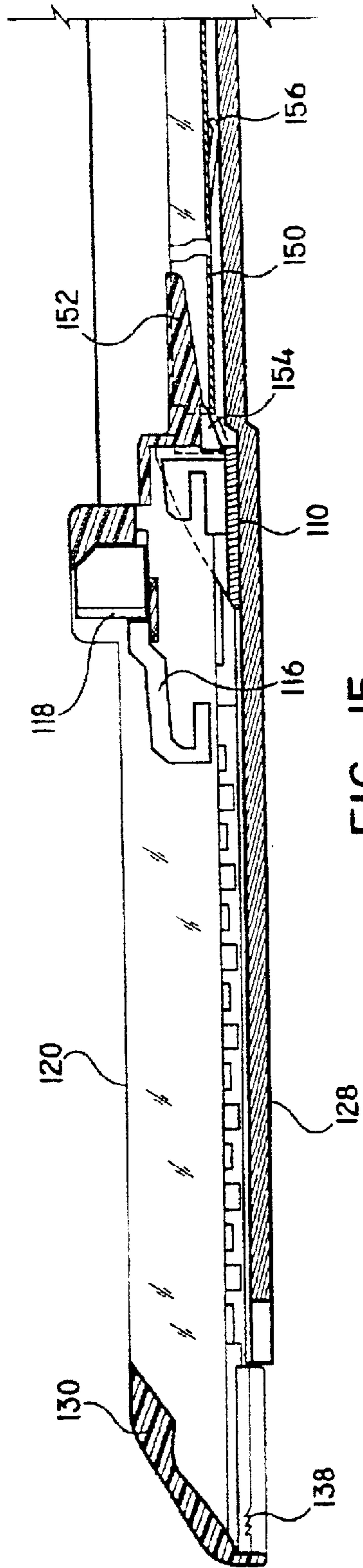

FIG. 15

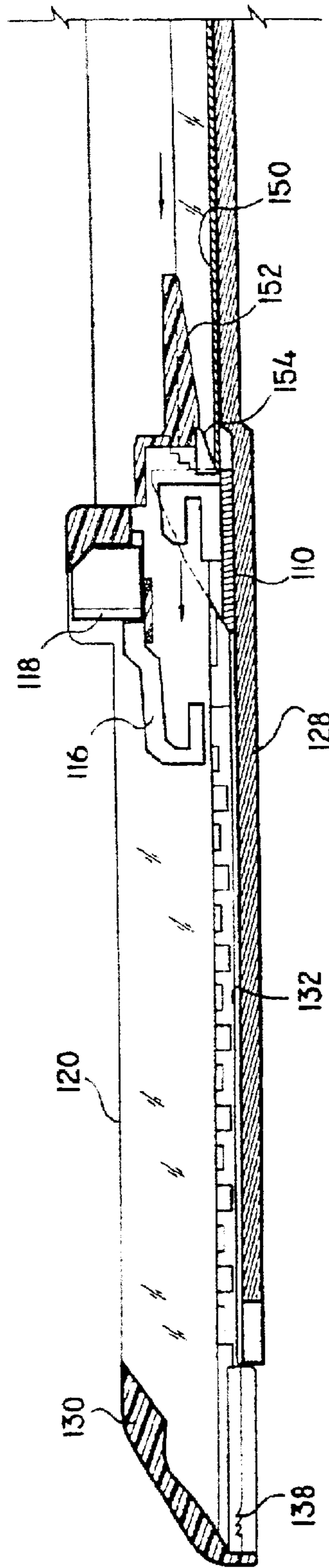
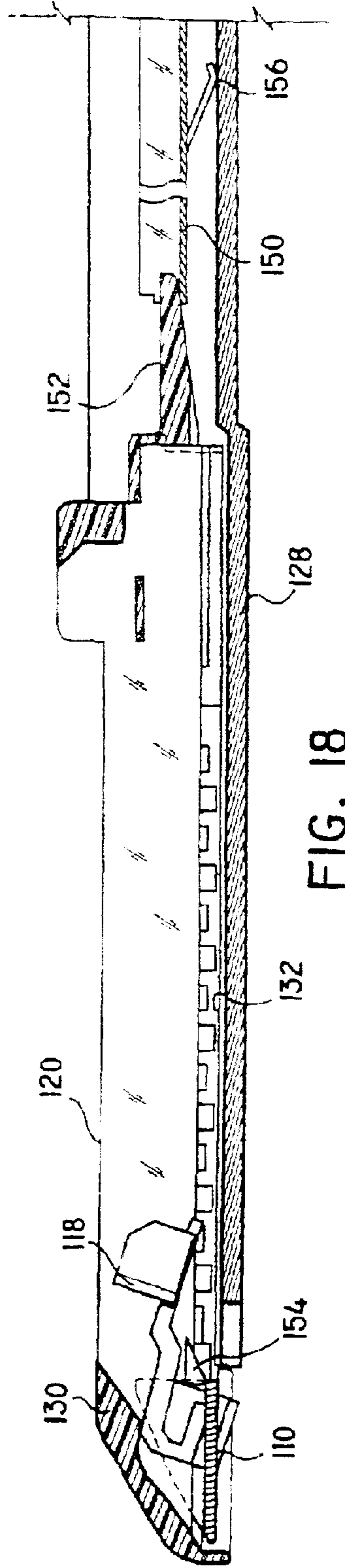
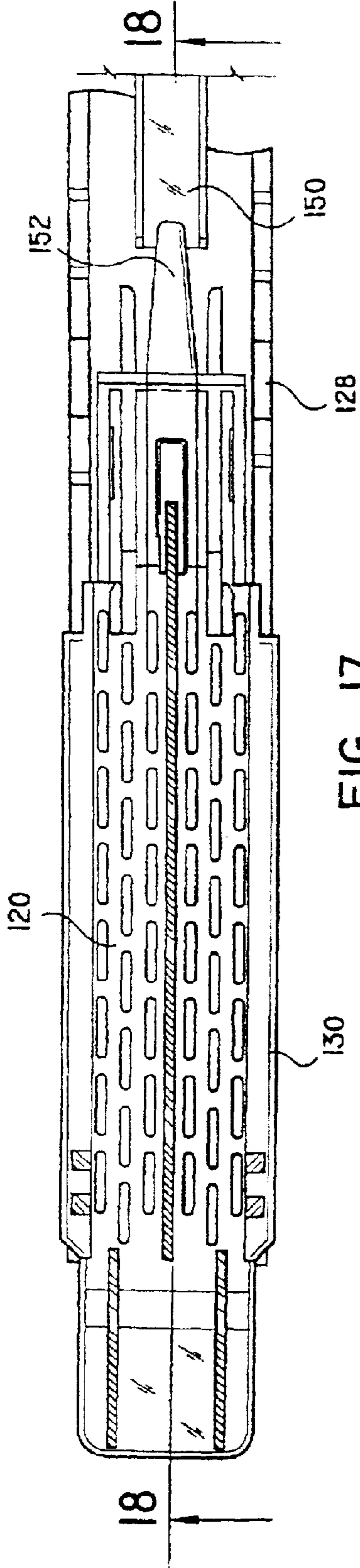

FIG. 16



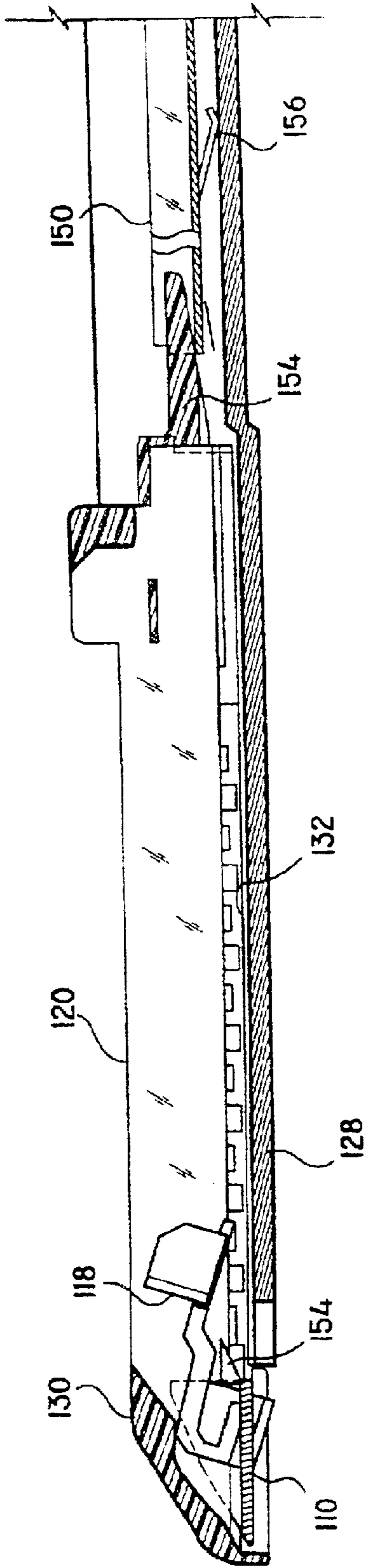

FIG. 19

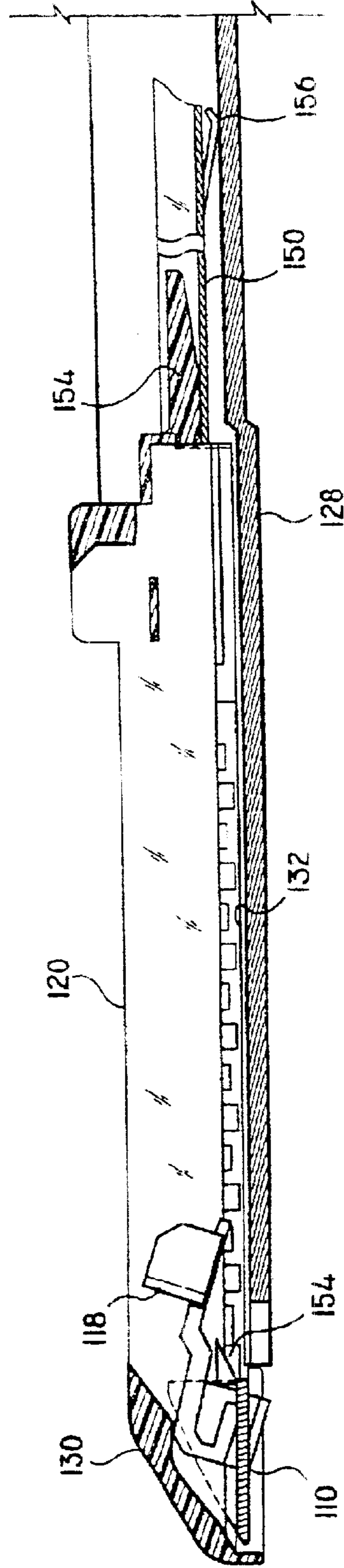

FIG. 20



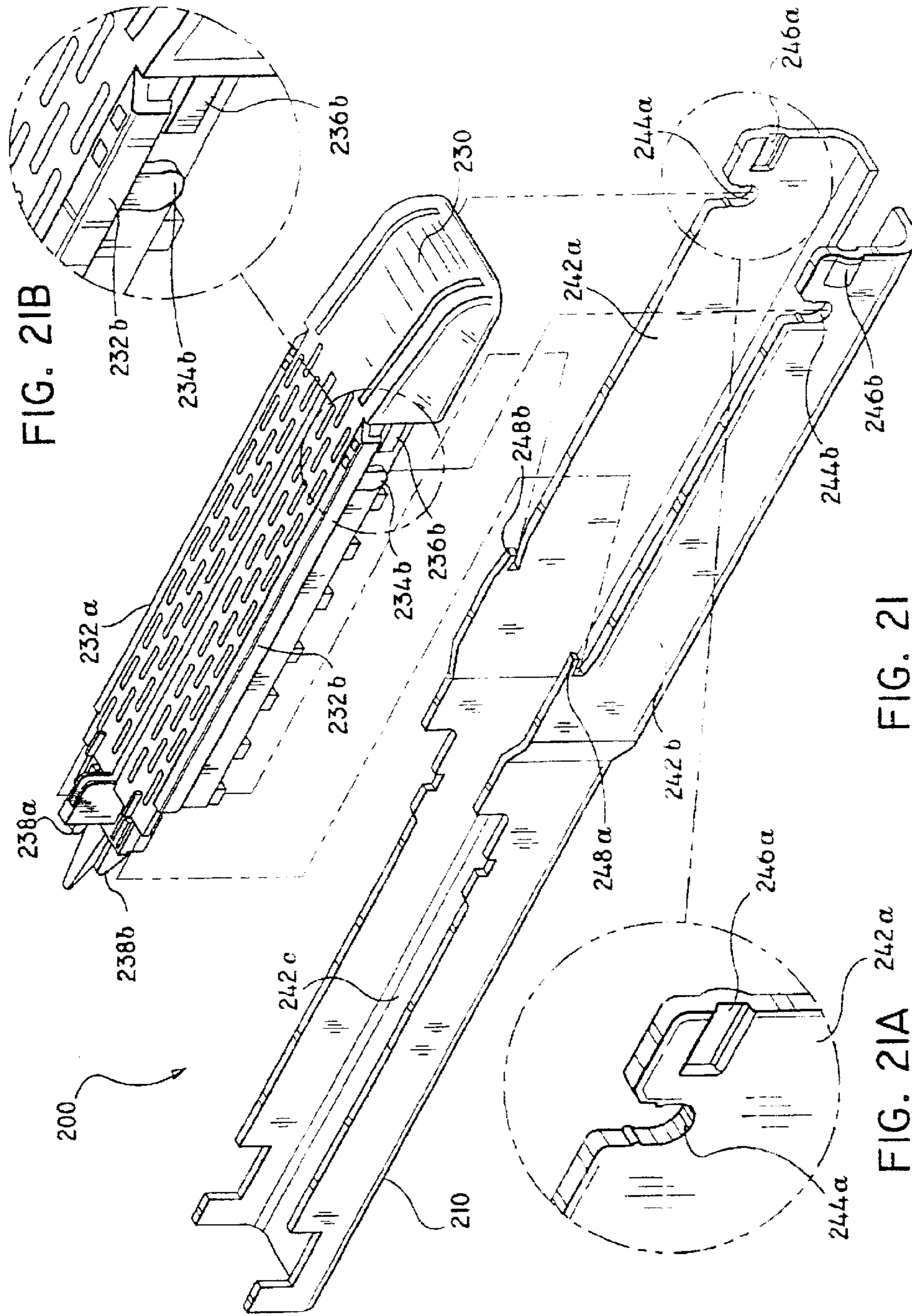

FIG. 21B

FIG. 21

FIG. 21A

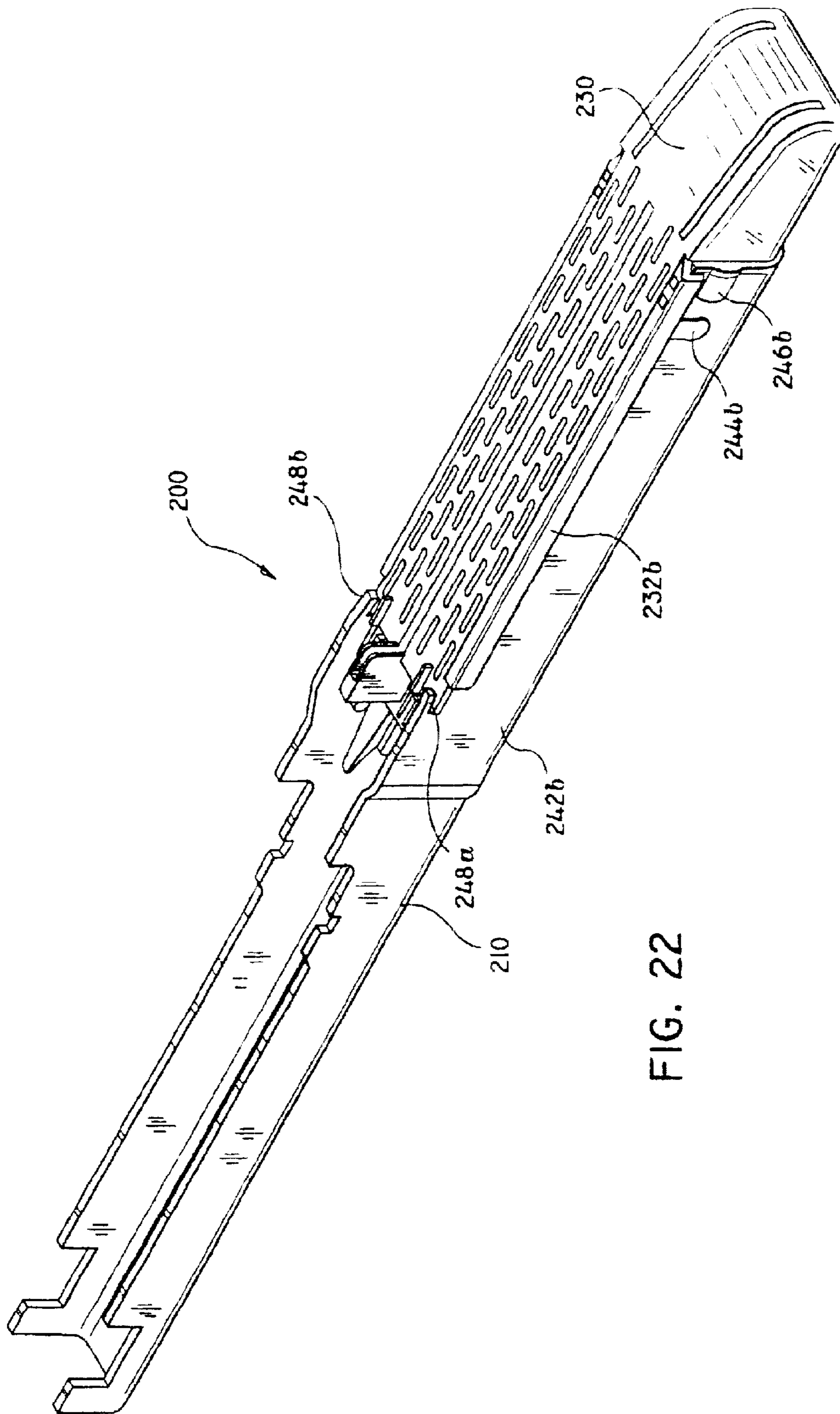

FIG. 22

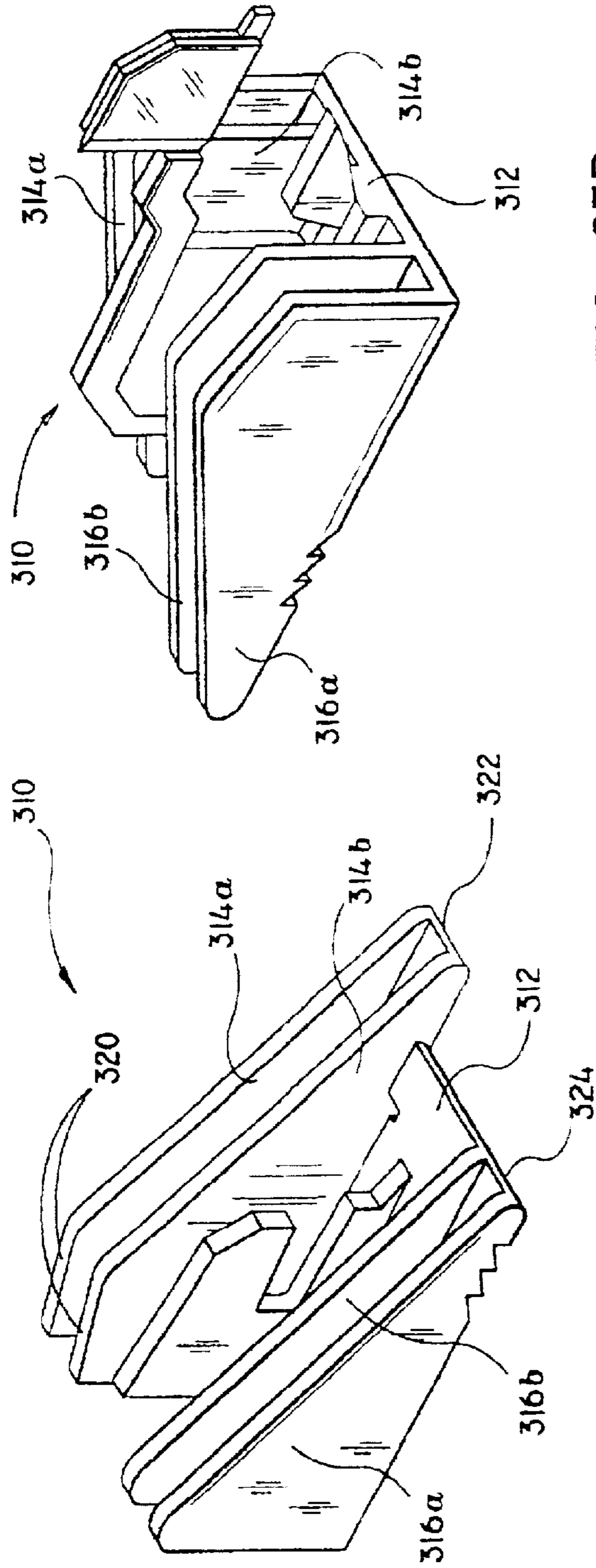

FIG. 23B

FIG. 23A

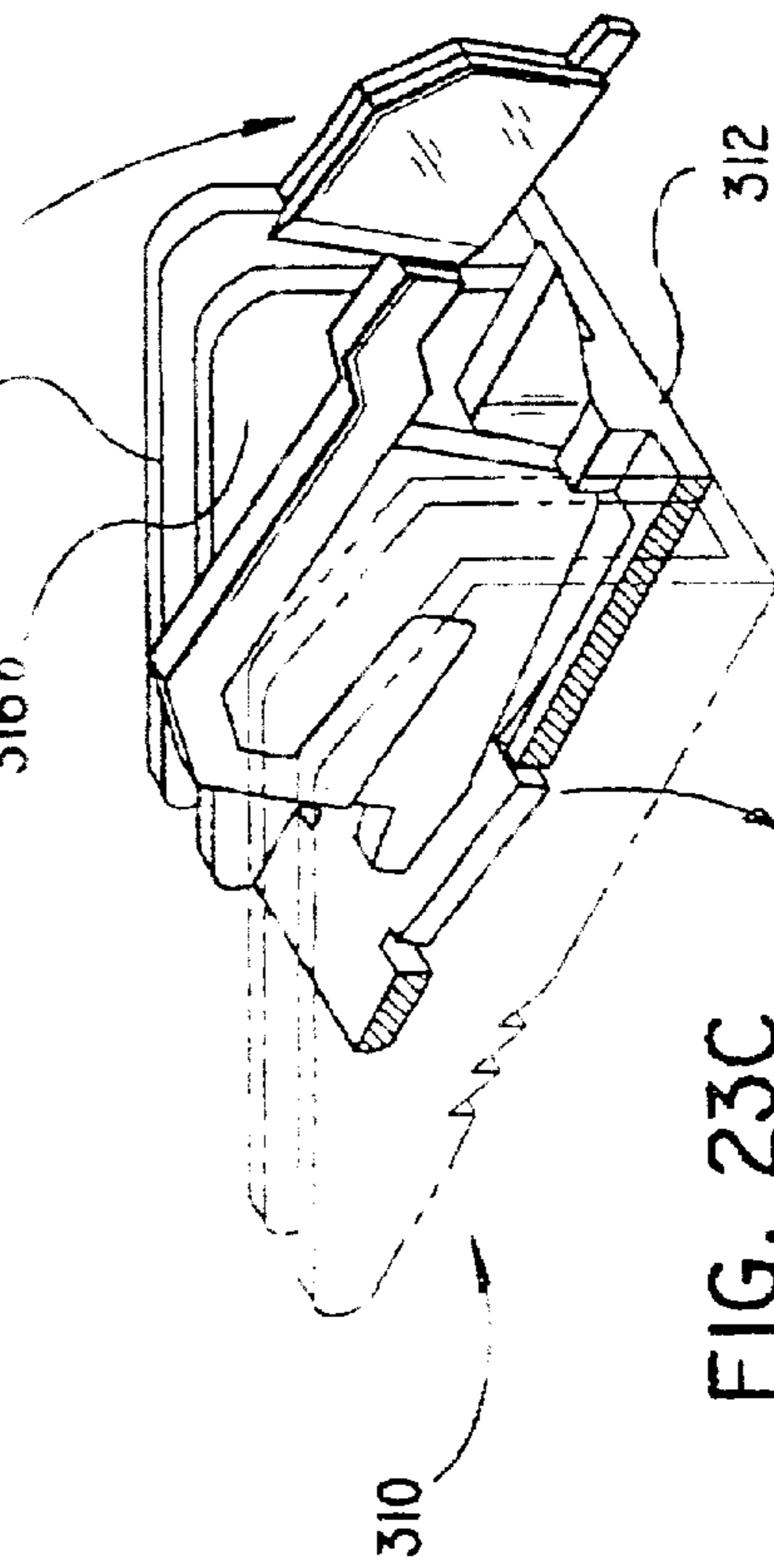

FIG. 23C

## DISPOSABLE LOADING UNIT FOR SURGICAL STAPLER

**Matter enclosed in heavy brackets [ ] appears in the original patent but forms no part of this reissue specification; matter printed in italics indicates the additions made by reissue.**

This application is a continuation of U.S. application Ser. No. 08/501,197 filed Jul. 11, 1995, now U.S. Pat. No. 5,752,644.

### BACKGROUND

#### 1. Technical Field

This invention relates to a disposable loading unit for a surgical stapler, and more particularly, to a disposable loading unit for an apparatus configured to sequentially apply a plurality of surgical fasteners to body tissue and optionally incise the fastened tissue.

#### 2. Background of Related Art

Surgical devices wherein tissue is first grasped or clamped between opposing jaw structure and then joined by surgical fasteners are well known in the art. In some instruments a knife is provided to cut the tissue which has been joined by the fasteners. The fasteners are typically in the form of surgical staples but two part polymeric fasteners can also be utilized.

Instruments for this purpose can include two elongated members which are respectively used to capture or clamp tissue. Typically, one of the members carries a staple cartridge which houses a plurality of staples arranged in at least two lateral rows while the other member has an anvil that defines a surface for forming the staple legs as the staples are driven from the staple cartridge. Generally, the stapling operation is effected by cam bars that travel longitudinally through the staple cartridge, with the cam bars acting upon staple pushers to sequentially eject the staples from the staple cartridge. A knife can travel between the staple rows to longitudinally cut and/or open the stapled tissue between the rows of staples. Such instruments are disclosed, for example, in U.S. Pat. No. 3,079,606 and U.S. Pat. No. 3,490,675.

A later stapler disclosed in U.S. Pat. No. 3,499,591 applies a double row of staples on each side of the incision. This is accomplished by providing a disposable loading unit in which a cam member moves through an elongate guide path between two sets of staggered staple carrying grooves. Staple drive members are located within the grooves and are positioned in such a manner so as to be contacted by the longitudinally moving cam to effect ejection of the staples. Other examples of such staplers are disclosed in U.S. Pat. Nos. 4,429,695 and 5,065,929.

Each of the instruments described above were designed for use in conventional surgical procedures wherein surgeons have direct manual access to the operative site. However, in endoscopic or laproscopic procedures, surgery is performed through a small incision or through a narrow cannula inserted through small entrance wounds in the skin. In order to address the specific needs of endoscopic and/or laparoscopic surgical procedures, endoscopic surgical stapling devices have been developed and are disclosed in, for example, U.S. Pat. Nos. B5,040,715 (Green, et al.); 5,307,976 (Olson, et al.); 5,312,023 (Green, et al.); 5,318,221 (Green, et al.); 5,326,013 (Green, et al.); and 5,332,142 (Robinson et al.).

U.S. Surgical, the assignee of the present application, has manufactured and marketed endoscopic stapling

instruments, such as the Multifire ENDO GIA\* 30 and Multifire ENDO GIA\* 60 instruments, for several years. These instruments have provided significant clinical benefits. Nonetheless, improvements are possible, for example, by reducing the cost and complexity of manufacture and/or reducing the amount of material discarded at the conclusion of a surgical procedure. In making any such improvements, it would be highly desirable not to sacrifice any of the important benefits of the MULTIFIRE ENDO GIA\* 30 and 60 instruments as compared to other commercially available products, e.g., the endoscopic stapling instruments manufactured and marketed by Ethicon, Inc. For example, any improvement should advantageously provide a fresh knife blade for each firing of the instrument and ensure that the disposable loading unit is securely retained in the stapling instrument unless and until the operating team chooses to remove it. These advantages have historically been found in the U.S. Surgical instruments, but not in the Ethicon instruments.

Therefore, a need exists for a disposable loading unit that exhibits all of the benefits of the present assignee's commercially available instruments while also reducing the cost and complexity of manufacture and/or reducing the amount of material discarded at the conclusion of a surgical procedure.

### SUMMARY

The subject application is directed to a disposable loading unit for a surgical stapling apparatus configured to sequentially apply a plurality of surgical fasteners to body tissue during a surgical procedure. The apparatus with which the disposable loading unit is associated includes an actuation assembly for effectuating a fastener applying operation, and a housing mountable to a surgical stapling instrument for receiving and detachably supporting the disposable loading unit. The housing may be removably mounted to the stapler apparatus.

The disposable loading unit includes a staple cartridge body having a longitudinal pathway extending therethrough and a plurality of spaced apart retention slots defined therein each supporting a respective surgical fastener, a plurality of fastener ejection members disposed within the plurality of spaced apart retention slots and communicating with the longitudinal pathway. The disposable loading unit also includes an actuator supported within the staple cartridge body and configured to engage the actuation assembly of the apparatus and translate through the longitudinal pathway to contact the fastener ejection members and thereby sequentially eject the surgical fasteners from their respective retention slots.

The actuator includes a base portion and at least two upstanding parallel cam plates each preferably defining an angled leading edge for contacting the fastener ejection members. In one embodiment, the leading edge of each cam plate is configured to controllably deform as the actuator translates through the staple cartridge body. Alternatively, each of the cam plates is configured to be reduced in size or mass as the actuator translates through the staple cartridge body. In a further alternative embodiment, the cam plates can be fabricated from a rigid material that does not significantly deform during fastener ejection.

The disposable loading unit can also include an optical cutting member that is configured to translate through the staple cartridge body in association with the actuator to form an incision in the stapled body tissue. In operation, the cutting member intersects the tissue contacting plane during

its translation through the staple cartridge body, and is moved out of intersection with the tissue contacting plane at the conclusion of a stapling operation. The cutting member is single use only, thereby ensuring maximum sharpness for each firing.

In a preferred embodiment of the disposable loading unit, structure is associated with the disposable loading unit for releasably engaging the housing to inhibit movement of the disposable loading unit within the housing during a fastener applying operation. Structure associated with the disposable loading unit for releasably engaging the housing includes a pair of elongate struts dimensioned and configured to engage the opposed side walls of the housing to inhibit lateral movement of the disposable loading unit. A pair of opposed detents which are dimensioned and configured to engage a pair of corresponding notches defined in the opposed side walls of the housing can also be provided to inhibit longitudinal movement of the disposable loading unit. Furthermore, a pair of opposed outwardly extending protuberances which are dimensioned and configured to engage a pair of corresponding indentations defined in the opposed side walls of the housing can be provided to inhibit vertical movement of the disposable loading unit. The disposable loading unit can also include a pair of spaced apart wings which extend from a proximal end of the staple cartridge body and include angled guide surfaces for guiding the disposable loading unit into the housing during assembly.

In another preferred embodiment of the disposable loading unit, at least one camming surface is provided for facilitating engagement of the actuator and the actuation assembly of the surgical apparatus to enable the performance of a fastener applying operation. Preferably, a first cam wing depends from a proximal end of the staple cartridge body and defines a first angled cam surface, and a second cam wing depends from a proximal end of the actuator and defines a second angled cam surface. When the first and second angled cam surfaces are aligned, the actuation assembly of the stapler can engage the actuator and drive it through the staple cartridge body. However, when the angled cam surfaces are spaced from one another, i.e. when the actuator is at the distal end of the staple cartridge body, the actuation assembly will be unable to engage the actuator and the apparatus will be rendered inoperative until the used disposable loading unit is removed from the apparatus.

In another preferred embodiment, structure is provided on the fastener actuator and the staple cartridge body for retaining the actuator at the distal end of the staple cartridge body after the fasteners have been fired.

Advantageously, the disposable loading unit disclosed herein provides a replaceable unit which preserves the advantage of a disposable loading unit over a replaceable staple cartridge; namely, providing new cam plates and/or knife with each disposable loading unit.

Further features of the surgical apparatus will become more readily apparent to those skilled in the art from the following detailed description of the invention taken in conjunction with the drawings.

#### BRIEF DESCRIPTION OF THE DRAWINGS

Various preferred embodiments of the disposable loading unit of the subject application will be described hereinbelow with reference to the drawings wherein:

FIG. 1 is a perspective view of a surgical stapling apparatus which employs a disposable loading unit constructed in accordance with a preferred embodiment;

FIG. 2 is a perspective view of a disposable loading unit constructed in accordance with a preferred embodiment and illustrating the position of the actuator prior to a fastener applying operation;

FIGS. 3-5 are perspective views of the disposable loading unit of FIG. 2, during a fastener applying operation as the actuator translates through the staple cartridge body to sequentially eject surgical fasteners from the staple cartridge and drive them against the anvil member to be formed thereby;

FIG. 6 is an exploded perspective view of another disposable loading unit constructed in accordance with a preferred embodiment that has a cutting blade associated with the actuator;

FIG. 6A is an enlarged view of the indicated area of detail of FIG. 6;

FIG. 7 is a top plan view of the disposable loading unit of FIG. 6;

FIG. 8 is a side elevational view in cross-section taken along line 8-8 of FIG. 7 with the actuation disposed in a proximal position within the staple cartridge body;

FIG. 9 is a side elevational view of the disposable loading unit of FIG. 8, with the actuator disposed in a distal position prior to the cutting blade being moved out of intersection with the tissue contacting surface of the staple cartridge body;

FIGS. 10A and 10B are perspective views of the actuator and the cutting blade carrier in an orientation corresponding to their respective position shown in FIG. 9;

FIG. 11A is a side elevational view in cross-section of the distal portion of the disposable loading unit as the cutting blade is moved out of intersection with the tissue contacting surface of the staple cartridge body;

FIG. 11B is a perspective view of the actuator and cutting blade carrier in an orientation corresponding to their respective position shown in FIG. 11A;

FIG. 12A is a side elevational view in cross-section of the distal portion of the disposable loading unit with the cutting blade moved out of intersection with the tissue contacting surface of the staple cartridge body;

FIG. 12B is a perspective view of the actuator and the cutting blade carrier in an orientation corresponding to their respective positions shown in FIG. 12A;

FIG. 13 is a cross-sectional view of the disposable loading unit taken along line 13-13 of FIG. 12A;

FIG. 14 is a cross-sectional view of the disposable loading unit taken along line 14-14 of FIG. 13 illustrating the actuator in a locked position at the distal end of the disposable loading unit;

FIG. 15 is a side elevational view in cross-section of a disposable loading unit and housing constructed in accordance with a preferred embodiment prior to a fastening procedure wherein the actuator is disposed in a proximal position, spaced from the cutting blade carrier, and partially engaged by an actuation channel;

FIG. 16 is a side elevational view in cross-section of the disposable loading unit illustrated in FIG. 15 with the actuator fully engaged by the actuation channel;

FIG. 17 is a top plan view of the disposable loading unit, housing, and actuation channel;

FIG. 18 is a side elevational view in cross-section taken along line 18-18 of FIG. 17 illustrating the actuator and cutting blade in a locked position at the distal end of the staple cartridge body, and the actuation channel disposed in

5

a retracted and elevated position adjacent the proximal end of the disposable loading unit;

FIG. 19 is a side elevational view of the disposable loading unit illustrated in FIG. 18 wherein the actuation channel is engaged with a camming member extending from the rear end portion of the staple cartridge body;

FIG. 20 is a side elevational view of the disposable loading unit illustrated in FIG. 18 wherein a distal end of the actuation channel is in abutment with a proximal end portion of the staple cartridge body;

FIG. 21 is an exploded perspective view of a disposable loading unit and a housing constructed in accordance with a preferred embodiment illustrating structures for inhibiting movement of the disposable loading unit relative to the housing during a fastening operation;

FIG. 21A is an enlarged view of the indicated area of detail of FIG. 21;

FIG. 21B is an enlarged view of the indicated area of detail of FIG. 21;

FIG. 22 is a perspective view of the disposable loading unit and the housing illustrated in FIG. 21 in an assembled condition; and

FIGS. 23A–23C are perspective views of another actuator constructed in accordance with a preferred embodiment which has staggered cam plates to balance fastener driving forces during a fastening operation.

#### DETAILED DESCRIPTION OF PREFERRED EMBODIMENTS

In the drawings and in the description which follows, the term “proximal”, as is traditional, will refer to the end of the stapling apparatus which is closed to the operator, while the term “distal” will refer to the end of the apparatus which is furthest from the operator.

The stapling apparatus with which the disposable loading unit of the present disclosure is associated shall be discussed in terms of both conventional and endoscopic procedures. However, use herein of terms such as “endoscopic”, “endoscopically”, and “endoscopic portion”, among others, should not be construed to limit the present apparatus for use only in an endoscopic environment. To the contrary, it is believed that the apparatus and disposable loading unit described herein may find use in procedures wherein access is limited to a small incision including but not limited to arthroscopic and/or laparoscopic procedures, and in other non-endoscopic procedures.

Referring now to the drawings wherein like reference numerals identify similar structural elements of the subject apparatus, there is illustrated in FIG. 1 a surgical stapling apparatus designated generally by reference numeral 10. Stapling apparatus 10 is configured for utilization during laparoscopic and endoscopic surgical procedures and includes a handle assembly 12, an elongated body portion 14, and a fastener applying assembly 16 which is associated with a distal end of elongated portion 14. Fastener applying assembly 16 includes a fastener containing portion 18 and an anvil member 20. Handle assembly 12 includes a clamping handle 22 for effectuating approximation of anvil member 20 and fastener containing portion 18, and an actuation handle 24 for effectuating a fastener applying operation. A stapling apparatus of this type is disclosed in commonly assigned U.S. Pat. No. 5,318,221, the disclosure of which is herein incorporated by reference.

Referring now to FIGS. 2–5A, the fastener containing portion 18 of fastener applying assembly 16 includes a

6

housing 28 dimensioned and configured to receive and detachably support a disposable loading unit. The disposable loading unit includes a staple cartridge body 30 having a longitudinal pathway 32 extending therethrough, and a plurality of spaced apart fastener retention slots 36 formed therein. Each retention slot 36 is dimensioned and configured to support a respective surgical fastener 35 as shown. A plurality of fastener ejectors 40 are also supported within the staple cartridge body 30 and are each associated with surgical fasteners 35. As shown, ejectors 40 are each preferably associated with three surgical fasteners. However, other quantities of surgical fasteners can be associated therewith, such as one or two fasteners per ejector. Each ejector 40 has an angled camming surface 42 which is dimensioned and configured to engage an actuator 50, included in the disposable loading unit, as the actuator translates through pathway 32 under the influence of an actuation shaft or channel 44 of the stapling apparatus. Actuation channel 44 is configured to translate through the body portion 14 of surgical apparatus 10 and is controlled through manipulation of the actuation handle 24 of handle assembly 12.

As best seen in FIGS. 3 and 3A, actuator 50 includes a base portion 52 and four spaced apart upstanding cam plates 54. Each cam plate 54 has an angled camming surface 56 for sequentially engaging the camming surface 42 of each fastener ejector 40 as actuator 50 translates through pathway 32. Once contacted or engaged by actuator 50, each ejector 40 is driven vertically in the direction indicated by arrow “Y”, urging three adjacent fasteners 35 from their respective retention slots 36 to be driven and formed against the fastener forming surface of anvil member 20 (shown in phantom).

Referring to FIGS. 3–5A, cam plates 54 can be formed of a material such as plastic, or a fibrous composite, which deforms as actuator 50 translates distally and engages fastener ejectors 40. More particularly, cam plates 54 are configured to reduce in mass or decrease in size as actuator 50 is driven through staple cartridge body 30 in the direction indicated by arrow “X<sub>0</sub>”. The reduction in mass and the decrease in size results from the forced frictional contact between the camming surfaces 56 of cam plates 54 and the camming surfaces 42 of fastener ejectors 40 under the influence of actuation shaft 44. To compensate for the change in size of actuator 50, ejectors 40 can gradually increase in vertical height to maintain consistent staple formation. Cam plates 54 can also be fabricated from a relatively non-deformable material such as, for example, stainless steel which will not significantly deform.

Following a fastener applying procedure illustrated in FIGS. 3–5A, the disposable loading unit including staple cartridge body 30 together with the actuated fastener ejectors 40 and the displaced actuator 50, is removed from housing 28, discarded, and replaced with a new fully loaded disposable loading unit that includes fasteners, ejectors, and a new actuator.

Referring now to FIGS. 6 and 6A, there is illustrated an alternative disposable loading unit 100 constructed in accordance with a preferred embodiment. The disposable loading unit is received in housing 128 and includes an alternative actuator 110. Actuator 110 includes a base portion 102 having an angled leading edge 102a, and four spaced apart upstanding cam plates 104 each defining a respective camming surface 106 in angular alignment with leading edge 102a. Base portion 102 includes a deflectable beam section 108 which supports an upstanding shank 112. A slot 114 is formed in shank 112 for receiving and engaging a corre-

spondingly dimensioned and configured flange **115** associated with blade carrier **116** as actuator **110** beings its translation through staple cartridge body **130**. Blade carrier **116** supports knife blade **118** which incises stapled body tissue as actuator **110** translates through staple cartridge body **130** during a fastener applying operation.

As best seen in FIG. 7, a longitudinal slot **125** is formed in staple cartridge body **130** for accommodating the longitudinal translation of knife blade **118** as it intersects the tissue contacting surface **120** of staple cartridge body **130** to engage and form an incision in stapled body tissue. As knife blade **118** approaches the distal end of pathway **132**, it is advantageously moved out of the plane defined by tissue contacting surface **120**, to prevent injurious contact therewith during removal of the disposable loading unit from housing **128**. Alternatively, it is contemplated that the disposable loading unit can further include housing **128**, such that the disposable loading unit includes the staple cartridge, actuator and housing.

Referring to FIG. 9, the advantageous displacement of knife blade **118** is caused by the interaction of an angled cam surface **122** (FIG. 8) formed at a leading edge of blade support **116** and an angled abutment surface **124** formed at the distal end of staple cartridge body **130**. During a fastening operation, when cam surface **122** initially engages abutment surface **124**, the beam section **108** of actuator **110** is in substantially planar alignment with base portion **102**, as illustrated in FIGS. 10A and 10B. As actuator **110** continues to translate distally within staple cartridge body **130**, further interaction between cam surface **122** and abutment surface **124** causes beam section **108** to deflect angularly away from base portion **102**. Preferably, beam section **108** is caused to deflect sufficiently so that the entire knife blade **118** is withdrawn into staple cartridge body **130** beneath tissue contacting surface **120**, as illustrated in FIGS. 11A–11B. During the angular deflection of beam section **108**, the forces generated by the interaction of cam surface **122** and abutment surface **124** can be counteracted by a pair of opposed support wings **134a** and **134b** which depend proximally from actuator **110** and contact the floor of housing **128**. Support wings **134a** and **b** are preferably formed monolithically with actuator **110**.

Referring to FIGS. 13 and 14, when actuator **110** reaches its distal-most position within pathway **132** of staple cartridge body **130**, a plurality of angular ridges **136** formed on base portion **102** are engaged by a plurality of corresponding angular teeth **138** formed on staple cartridge body **130**. At such a time, actuator **110** is fixedly retained at the distal end of the staple cartridge body **130** and cannot be withdrawn therefrom. Ridges **136** and teeth **138** prevent the actuator and associated knife blade from becoming dislodging from the staple cartridge body after it has been discarded. Of course, ridges **136** and teeth **138** can be interchanged or other structures to prevent dislodgment of the actuator can be used.

Referring now to FIGS. 15 and 16, there is illustrated the actuator mechanism for effecting the longitudinal translation of actuator **110** during a fastening operation, and for preventing the actuation of surgical apparatus **10** after actuator **110** has been driven through staple cartridge body **130**. The actuation mechanism includes an elongated actuation channel **150** that translates in a longitudinal direction in response to manipulation of actuation handle **24** (See FIG. 1). Actuation channel **150** is preferably U-shaped and is configured to interact with a first camming wing **152** extending integrally from the proximal end of staple cartridge body **130**, and a second camming wing **154** extending integrally from the proximal end of actuator **110**.

As illustrated in FIG. 15, at the beginning of a fastening operation, as actuation channel **150** translates distally, it initially encounters the first camming wing **152** of staple cartridge body **130**. Camming wing **152** guides channel **150** toward the second camming wing **154** of actuator **110**, against the bias of an integral leaf spring **156** extending from actuation channel **150**. Alternatively, the channel could be cambered to eliminate the need for leaf spring **156**. As actuation channel **150** continues to travel distally, guided by camming wing **152**, it encounters the second camming wing **154** and is guided into contact with a proximal portion of base portion **102** of actuator **110**, as illustrated in FIG. 16. Thereafter, continued distal translation of actuation channel **150** drives actuator **110** through staple cartridge body **130** to sequentially eject surgical fasteners therefrom, as illustrated, for example, in FIGS. 3–5.

Referring to FIGS. 17 and 18, at the conclusion of a fastening operation, actuator **110** is disposed within the distal end portion of staple cartridge body **130**, knife blade **118** is moved out of intersection with tissue contacting surface **120**, and actuation channel **150** is retracted proximally to the position illustrated in FIG. 18. In this position, actuation channel **150** is biased into engagement with the first camming wing **152** by leaf spring **156**, or by its natural camber. If, at such a time, actuation channel **150** is driven distally, it will interact with the first camming wing **152**, as shown in FIG. 19, but will be unable to interact with the second camming wing **154** of actuator **110**. Thus, as illustrated in FIG. 20, the distal end of actuation channel **150** will abut and engage the proximal end of staple cartridge body **130** and will be prevented from translating distally. Actuation channel **150** will remain inoperative until the disposable loading unit from which fasteners have been expelled is removed from housing **128** and replaced with a new disposable loading unit having an actuator and knife disposed in a proximal position. As will be appreciated, if less than all fasteners are ejected from the staple cartridge and actuation handle **24** is released by the operator, the channel will return to the position shown in FIG. 18 and will be unable to re-enter the staple cartridge body. This desirably prevents re-use of a partially fired staple cartridge.

Referring now to FIGS. 21, 21A, 21B, and 22, an alternative disposable loading unit and housing constructed in accordance with a preferred embodiment are illustrated and are designated by reference numerals **200** and **210** respectively. Disposable loading unit **200** and housing **210** are provided with cooperative structures which function to releasably secure disposable loading unit **200** within housing **210** and inhibit lateral, longitudinal, and elevational movement of the disposable loading unit during a stapling procedure. In particular, disposable loading unit **200** includes a staple cartridge body **230** having opposed lateral struts **232a** and **232b** which are formed monolithically therewith and which extend substantially along the length thereof and define channels **233a** (not shown) and **233b**. Struts **232a** and **232b** releasably engage the upper portion of opposed side walls **242a** and **242b** of housing **210** and inhibit movement of the disposable loading unit within housing **210**.

A pair of opposed detents **234a** (not shown) and **234b** are formed adjacent the distal end of the staple cartridge **230** for engaging a pair of corresponding notches **244a** and **244b** formed in the opposed side walls **242a** and **242b** of housing **210**. The notches and the detents are configured to lockingly engage with each other and inhibit longitudinal or distal-to-proximal movement of the disposable loading unit within housing **210**. In addition, a pair of outwardly depending protuberances **236a** (not shown) and **236b** are formed on

staple cartridge **230** for engaging a pair of corresponding depressions **246a** and **246b** formed in the opposed side walls **242a** and **242b** of housing **210**. The protuberances and depressions are configured to inhibit vertical or elevational movement of the disposable loading unit within housing **210**.

Cartridge body **230** further includes a pair of proximally extending guide wings **238a** and **238b** which serve to guide staple cartridge body **230** into housing **210** during assembly. More particularly, guide wings **238a** and **238b** have respective angled guide surfaces which are dimensioned and configured to cause the proximal end of staple cartridge body **230** to slide relative to the floor **242c** of housing **210** as the staple cartridge body is engaged beneath a pair of inwardly extending housing projections **248a** and **248b** (FIG. 22).

Referring now to FIGS. 23a–23c, there is illustrated another actuator constructed in accordance with an alternative embodiment and designated generally by reference numeral **310**. Actuator **310** is configured to translate through staple cartridge body **230** in the same manner as actuator **110** to sequentially eject a plurality of surgical fasteners therefrom, and includes a base portion **312**, a first set of upstanding cam plates **314a** and **314b**, and a second set of upstanding cam plates **316a** and **316b**. Cam plates **314a** and **314b** preferably have generally flat top portions **320** and have a leading edge **322** disposed distal of both base portion **312** and leading edge **324** of cam plates **314a** and **314b**. The first set of cam plates are advantageously offset or staggered from the second set of cam plates to balance the fastener driving forces generated within the disposable loading unit during a fastening operation.

As used in the claims, “securing means” is intended to refer to ridges **136** and teeth **138** formed on actuator **110** and pathway **132**, respectively, and equivalents thereof.

As used in the claims, “camming means” is intended to refer to the camming wings of the actuator and equivalents thereof.

Although the foregoing description contains many specifics with respect to preferred embodiments, it will be readily apparent to those having ordinary skill in the art that changes and modifications may be made thereto without departing from the spirit or scope of the subject invention as defined by the appended claims. By way of example only, it is contemplated that the housing can be permanently mounted to the stapling apparatus with the disposable loading unit removably mounted thereto. Alternatively, the disposable loading unit can further include the housing, such that the housing is removably mounted to the stapling apparatus. It also is contemplated that greater or fewer cam plates can be included on the actuator.

We claim:

1. A disposable loading unit for a surgical stapling apparatus comprising:

- a) a staple cartridge body having a longitudinal pathway extending therethrough and a plurality of spaced apart retention slots defined therein, each supporting a respective surgical fastener;
- b) a plurality of fastener ejection members disposed adjacent the plurality of spaced apart retention slots and communicating with the longitudinal pathway;
- c) an actuator at least partially disposed within the staple cartridge body and configured to be translated through the longitudinal pathway to contact the fastener ejection members and thereby sequentially eject the surgical fasteners from their respective retention slots, the

actuator including a base portion defining a plane and having at least two upstanding parallel cam plates each defining an angled leading edge for contacting the fastener ejection members;

- d) a cutting member configured to translate through the staple cartridge body, the cutting member having a blade and a blade support, the blade support including a camming surface spaced from the blade configured to interact with an abutment surface defined within a distal end portion of the staple cartridge body, wherein the staple cartridge body includes a planar tissue contacting surface through which extends a linear slot to accommodate translation of the cutting member, the planar tissue contacting surface defining a tissue contacting plane, the cutting member intersecting the tissue contacting plane during the translation thereof, and moving out of intersection with the tissue contacting plane when the camming surface of the cutting member contacts the abutment surface of the staple cartridge body.

2. A disposable loading unit according to claim 1, wherein the cutting member is pivotably supported at least partially within the staple cartridge body.

3. A disposable loading unit according to claim 2, wherein the cutting member is pivotably supported by the actuator about a pivot axis located distally of the blade.

4. A disposable loading unit for a surgical stapling apparatus comprising:

- a) a staple cartridge body having a longitudinal pathway extending therethrough and at least two rows of spaced apart retention slots defined therein, each slot supporting a respective surgical fastener, the staple cartridge body defining a planar tissue contacting surface having a linear slot extending therethrough, the staple cartridge body further defining an abutment surface formed near a distal end thereof;
- b) a plurality of fastener ejection members disposed adjacent the plurality of spaced apart retention slots and communicating with the longitudinal pathway;
- c) an actuator at least partially disposed within the staple cartridge body, the actuator having:
  - i) a base portion; and
  - ii) at least two upstanding parallel cam plates extending from a base portion, each of the at least two cam plates defining an angled leading edge, such that the angled leading edges are longitudinally aligned with the at least two rows of spaced apart retention slots so as to contact the fastener ejection members upon translational movement of the actuator through the longitudinal pathway and to thereby sequentially eject the surgical fasteners from their respective retention slots; and

- d) a cutting member pivotably mounted with respect to the actuator and translatably slidable with the actuator in the linear slot of the staple cartridge body, the cutting member having a blade and a flange including an upper surface which interacts with the abutment surface of the staple cartridge body, the flange being spaced distally of the blade, the cutting member being pivotable from a first position intersecting a tissue contacting plane defined by the planar tissue cutting surface, to a second position out of intersection with the tissue contacting plane, the cutting member being pivotable to the second position when the camming surface of the cutting member contacts the abutment surface of the staple cartridge body.



11

5. A disposable loading unit for a surgical stapling apparatus comprising:

a staple cartridge body defining a longitudinal pathway and a plurality of spaced apart retention slots, each retention slot being dimensioned to receive a surgical fastener;

a plurality of fastener ejection members disposed adjacent the plurality of spaced apart retention slots and communicating with the longitudinal pathway;

an actuator at least partially disposed within the staple cartridge body and configured to be translated through the longitudinal pathway to contact the fastener ejection members and sequentially eject the surgical fasteners from their respective retention slots, the actuator including a base portion defining a plane and having at least two upstanding parallel cam plates each defining an angled leading edge for contacting the fastener ejection members;

a cutting member including a blade and a blade carrier, the cutting member being configured to translate through the staple cartridge body, the blade carrier including a flange configured to engage the base portion of the actuator;

wherein the staple cartridge body includes a planar tissue contacting surface through which extends a linear slot to accommodate translation of the cutting member, the planar tissue contacting surface defining a tissue contacting plane, the cutting member being movable from a first position intersecting the tissue contacting plane to a second position located beneath the tissue contacting plane.

6. A disposable loading unit according to claim 5, wherein the at least two upstanding parallel cam plates includes four upstanding parallel cam plates.

7. A disposable loading unit according to claim 6, wherein two of the four upstanding parallel cam plates are positioned on each side of the linear slot.

8. A disposable loading unit according to claim 5, wherein the blade is located proximally of the angled leading edge of each of the at least two upstanding parallel cam plates.

12

9. A disposable loading unit for a surgical stapling apparatus comprising:

a staple cartridge body having a planar tissue contacting surface defining a tissue contacting plane, said body defining a longitudinal pathway therethrough and a linear slot traversing said planar tissue contacting surface, said body further defining a plurality of fastener retention slots on both sides of said linear slot, said fastener retention slots slidably supporting a respective surgical fastener and at least a portion of a surgical fastener ejection member;

an actuator having a beam portion and at least two cam plates having distal camming surfaces, said actuator configured to move in at least a distal direction through said longitudinal pathway to sequentially engage said cam plates with a portion of said surgical fastener ejection members to drive said surgical fasteners transversely with respect to said longitudinal pathway;

a cutting member having a blade support and a blade, the blade support of said cutting member being connected to said beam portion of said actuator in a manner that allows said blade to translate with said actuator from adjacent a proximal end of said linear slot to adjacent a distal end of said linear slot to bisect said tissue contacting plane, said blade support including a proximally projecting flange which contacts the actuator, wherein when the actuator moves distally through said longitudinal pathway, the blade support, in cooperation with the beam portion of the actuator, maintains the blade in a cutting position.

10. A disposable loading unit according to claim 9, wherein said blade support is positioned proximal to said distal camming surfaces of said cam plates.

11. A disposable loading unit according to claim 9, wherein said longitudinal pathway defined in said staple cartridge body is configured to allow said blade to be lowered substantially out of said tissue contacting plane adjacent a distal portion of said linear slot.

\* \* \* \* \*