



US00RE38656E

(19) **United States**
(12) **Reissued Patent**
Berger et al.

(10) **Patent Number: US RE38,656 E**
(45) **Date of Reissued Patent: Nov. 23, 2004**

(54) **ANNUNCIATOR WITH INTERNAL TACHOMETER**

(75) Inventors: **Walter R. Berger**, Houston, TX (US);
Randol W. Read, Houston, TX (US)

(73) Assignee: **Murphy Industries, Inc.**, Tulsa, OK (US)

(21) Appl. No.: **10/289,299**

(22) Filed: **Nov. 6, 2002**

Related U.S. Patent Documents

Reissue of:

(64) Patent No.: **6,144,116**
Issued: **Nov. 7, 2000**
Appl. No.: **09/350,618**
Filed: **Jul. 9, 1999**

(51) **Int. Cl.**⁷ **H01H 83/00**

(52) **U.S. Cl.** **307/116; 307/66; 340/520; 123/198 R**

(58) **Field of Search** **307/66, 116; 340/520; 123/198 R**

(56) **References Cited**

U.S. PATENT DOCUMENTS

4,181,883 A 1/1980 Beeghly et al.
4,336,463 A * 6/1982 Beeghly 307/66
4,777,435 A 10/1988 Lepley et al.
5,563,456 A * 10/1996 Berger 307/66

OTHER PUBLICATIONS

Murphy, SI5-96122B Catalog Section 50 Jul. 1999
00-02-0255 Murphy, Tulsa, OK.*
Murphy, MK3-95052B, Catalog Section 50, Jan. 1998,
00-02-0116 Murphy, Tulsa, OK.*
Murphy, SHD3-97050B Catalog Section 20 Mar. 1999
00-02-0287 Murphy, Tulsa, OK.*

Merriam-Webster's Ninth New Collegiate Dictionary, 1983, pp. 1342-1343.

The Random House Dictionary of the English Language, 1966, pp. 1626-1627.

Data Sheet on PIC16C9XX, 1997 Microchip Technology Inc.

FlexiGuard Safety Control System Operating Manual, Rev. 4 (Form 1081), 09-90.

FlexiGuard Safety Control System Form 1080, 04-88.

1997 Microchip Technology Inc. PIC16C924 Microprocessor Data Sheet, pp. 141-142.

AMOT Controls Corp., FlexiGuard Safety Control System, Operating Manual, Form 1081 Rev 5, 03-94, p. 38-40.

AMOT Controls Corp., FlexiGuard and MicroGuard II Control Systems, Brochure, Form 1333.

AMOT Controls Corp., Intrinsically Safe Control Systems, Sales Literature, Revision 1, p. 4-2.

* cited by examiner

Primary Examiner—Robert DeBeradinis

(74) *Attorney, Agent, or Firm*—Moser, Patterson & Sheridan, LLP

(57) **ABSTRACT**

An annunciator device that utilizes a microprocessor allows for the inclusion of a tachometer or an hourmeter-tachometer, functions that typically require external instruments. A display circuit sequentially provides a digital readout indicative of a fault condition, engine speed and elapsed run time. The system draws sufficiently low current to be powered from a CD ignition or magnetic pickup power supply and backup battery. An annunciator device that allows for the inclusion of a tachometer, or a tachometer and an hourmeter, eliminates a great deal of cost by reducing instrument count, customer wiring, and overall instrument panel size.

37 Claims, 6 Drawing Sheets

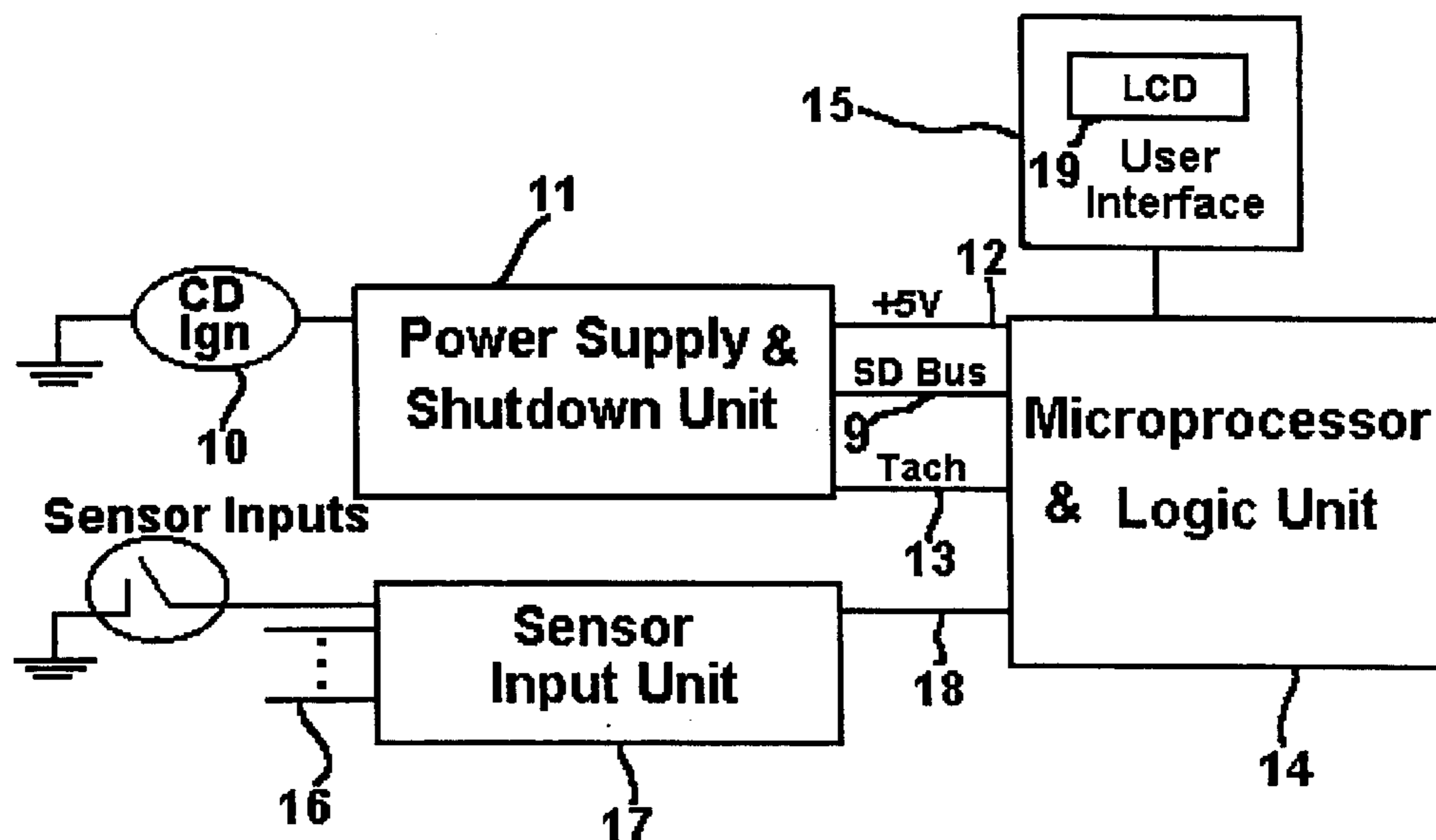

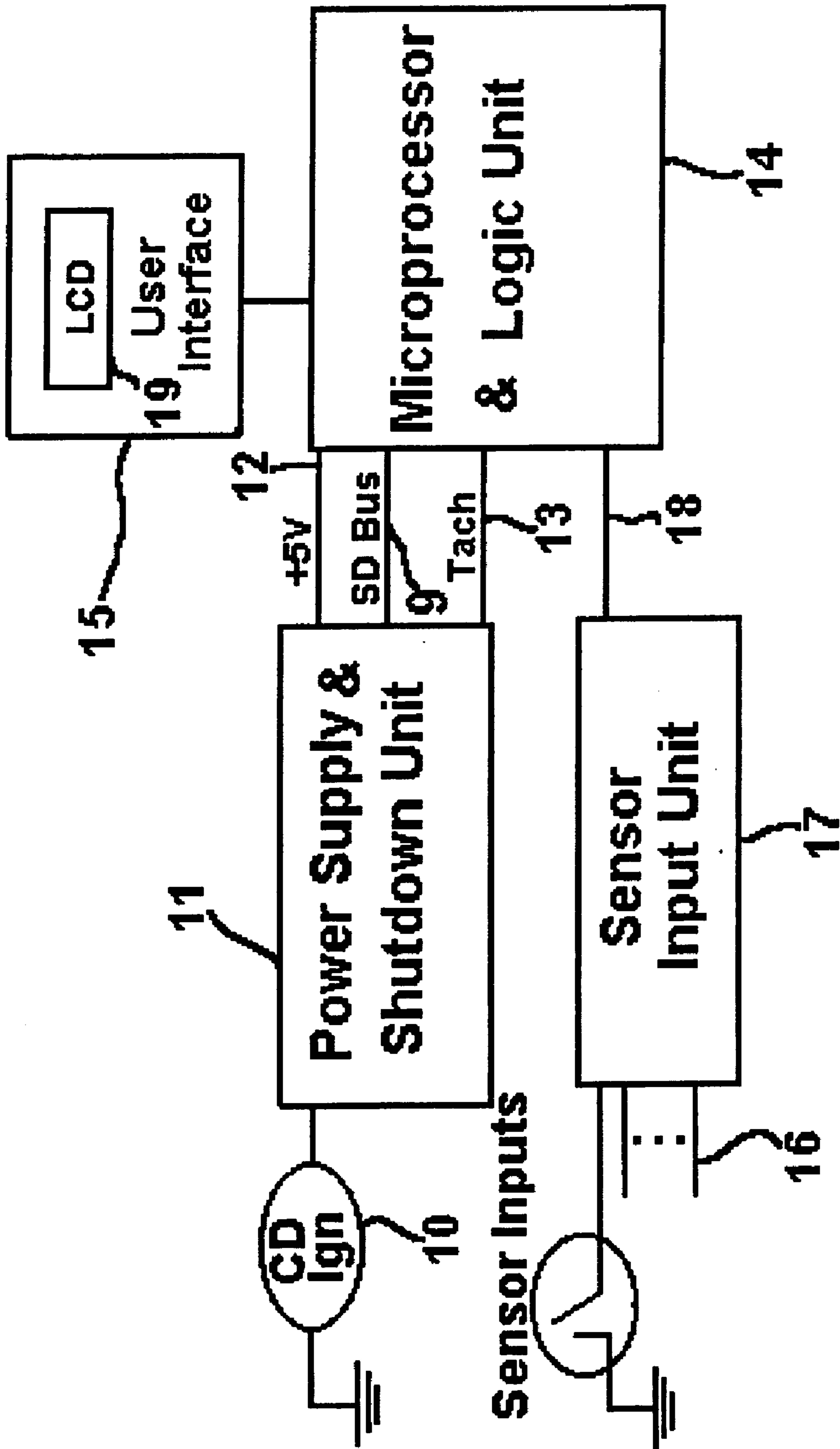

Fig. 1

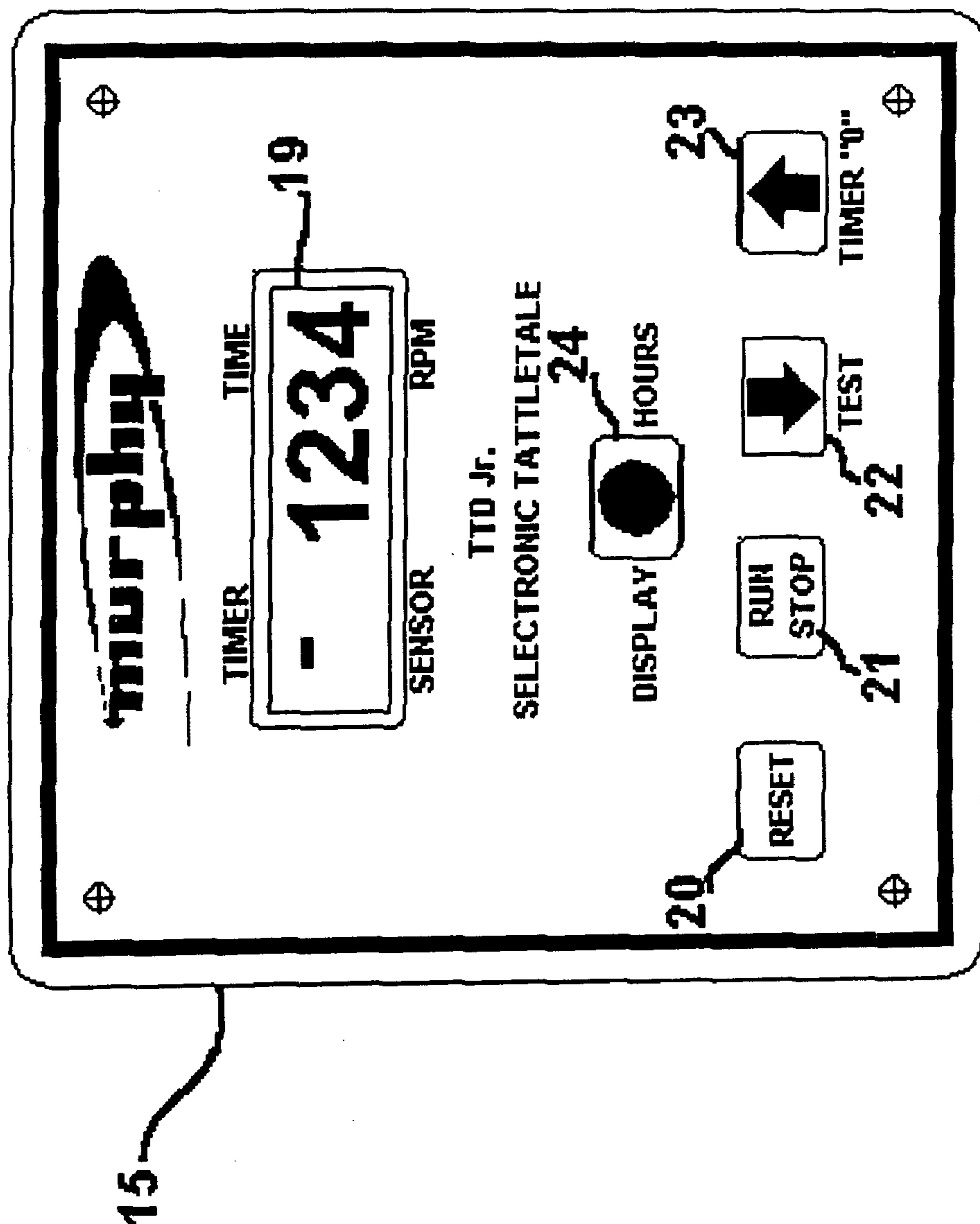

Fig. 2

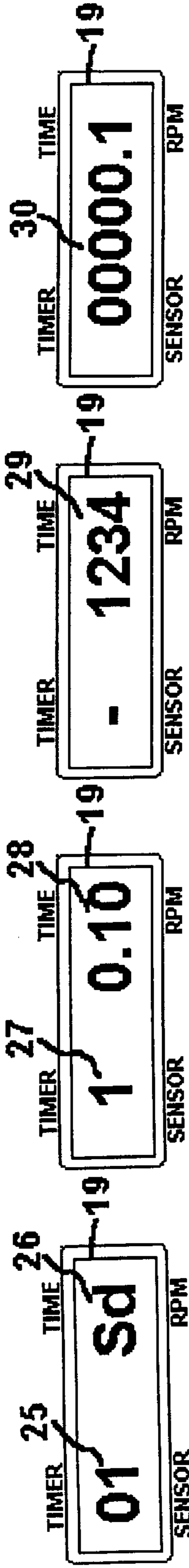

Fig. 3A

Fig. 3B

Fig. 3C

Fig. 3D

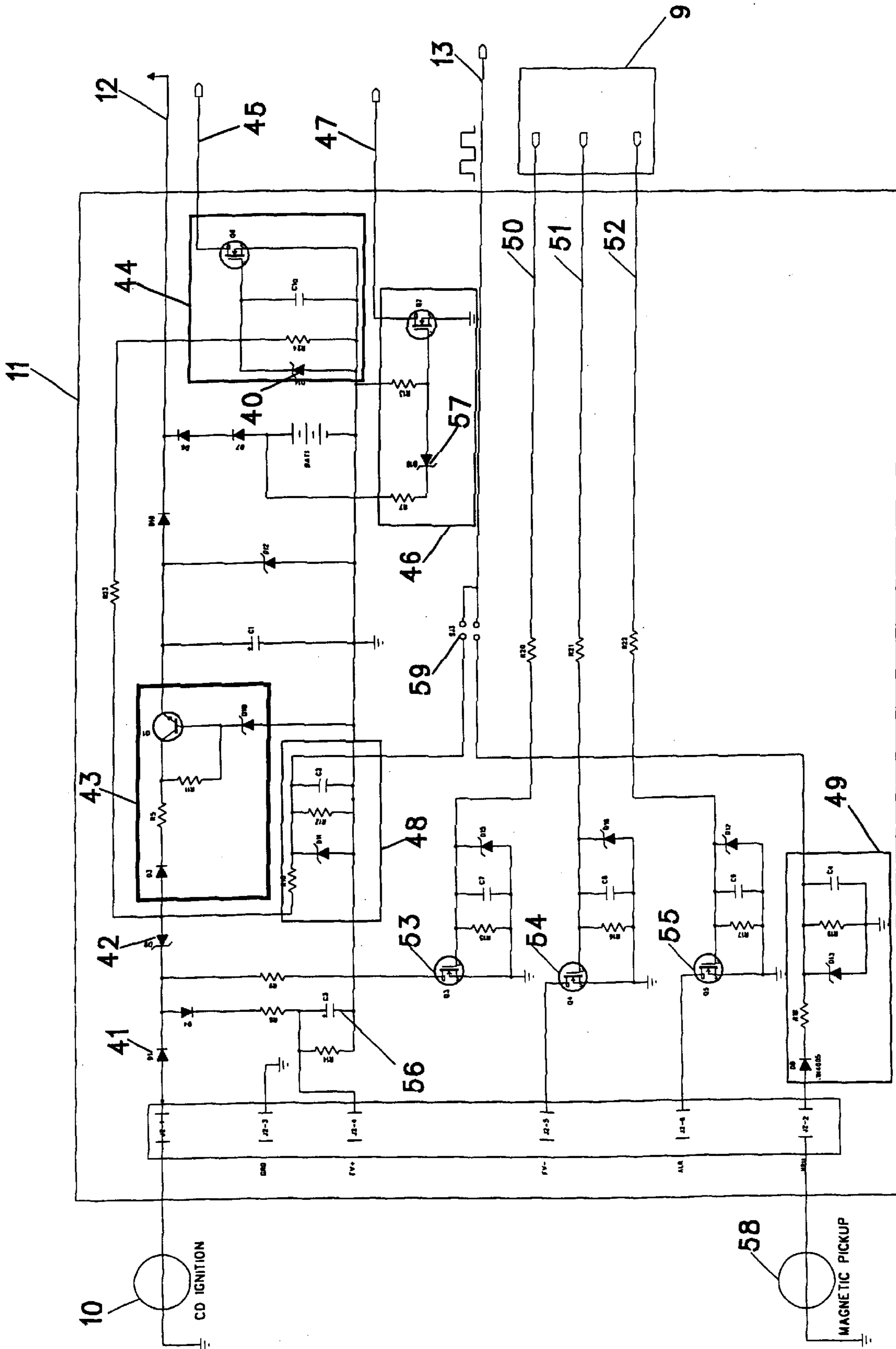

FIG. 4

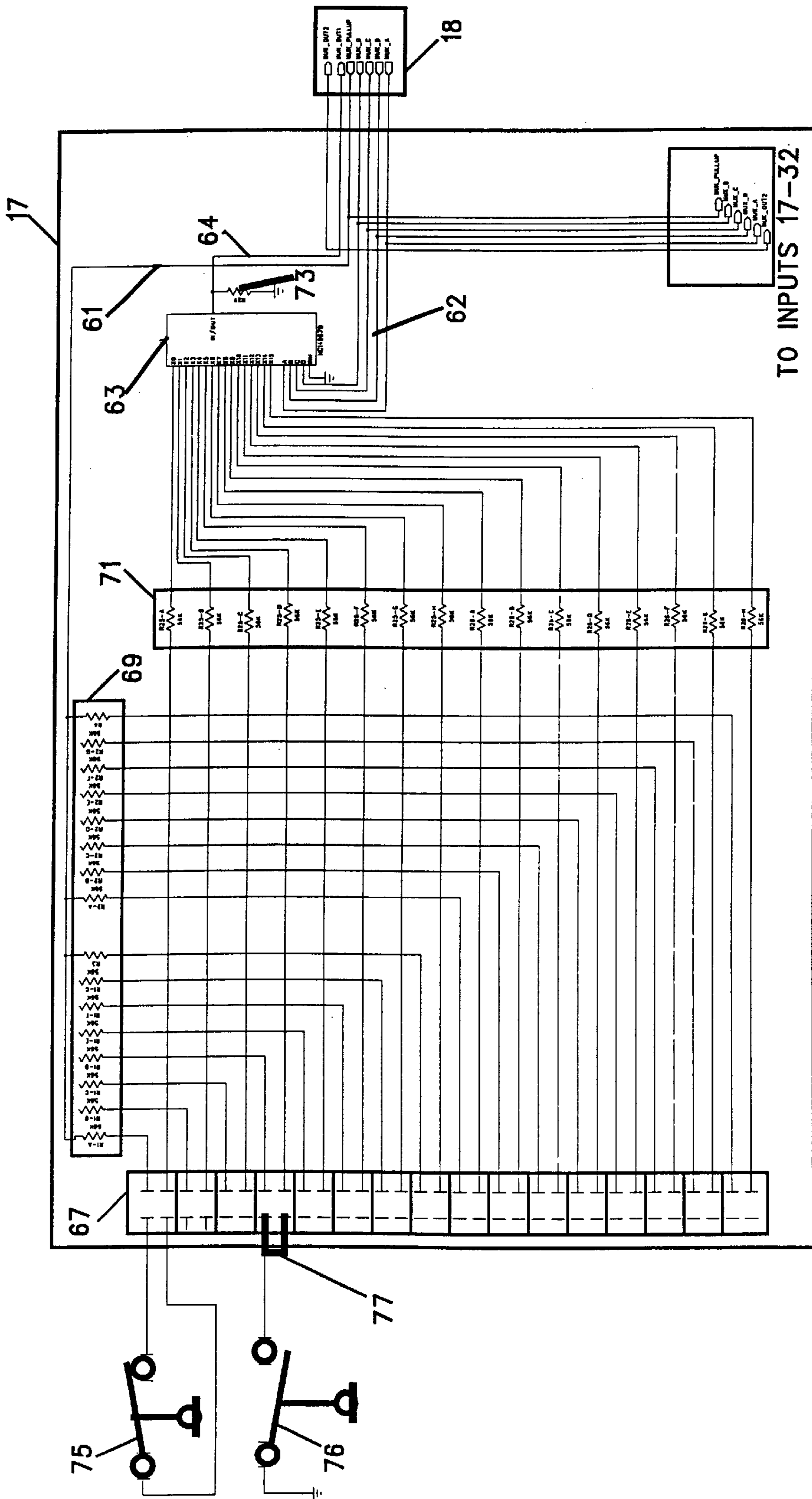

FIG. 5

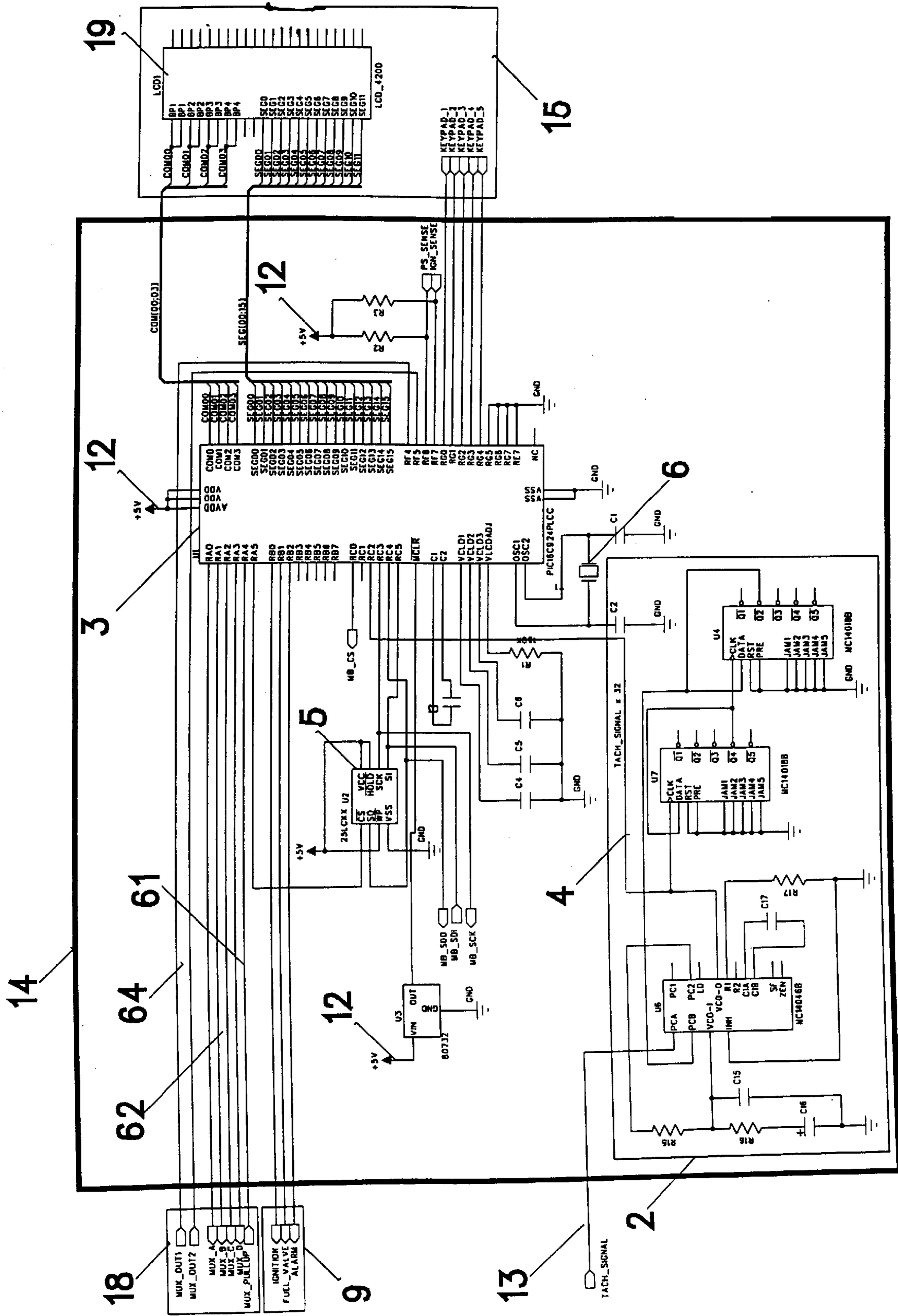

FIG. 6

1

ANNUNCIATOR WITH INTERNAL
TACHOMETER

Matter enclosed in heavy brackets [] appears in the original patent but forms no part of this reissue specification; matter printed in italics indicates the additions made by reissue.

BACKGROUND OF THE INVENTION

This invention relates to an annunciator, specifically to a microprocessor-based annunciator with an internal tachometer.

Annunciators are used for control and protection of remotely located internal combustion engines. Annunciators monitor a plurality of sensor inputs indicative of various engine parameters, such as oil pressure, water temperature, and engine speed. If one of these parameters is out of range, the annunciator triggers the shutdown of the engine and displays the fault condition, generally according to a sensor number. It is particularly important to monitor engine speed, because of the damage to the engine that can occur in a short period of time if engine speed exceeds acceptable levels.

Such remotely located engines are prevalent in oil field and pipeline locations where there may not be a readily available electric power supply. In such instances, annunciators must draw sufficiently low current to be powered from the Capacitor Discharge (CD) ignition of the engine being monitored or a magnetic pickup installed on the flywheel, and backed up by a small long life battery. In the field, CD ignitions are only able to supply a minimal amount of power to auxiliary equipment. Because of this, the drain or load of an annunciator must be minimal to avoid affecting the efficiency of the ignition system, especially during starting periods. Likewise since magnetic pickups are used to provide tachometer inputs, the drain or load of an annunciator must not degrade the pickup signal.

U.S. Pat. No. 4,336,463, expressly incorporated herein, discloses such a low power annunciator designed with digital logic. It is a disadvantage of such an annunciator, however, that it requires an external tachometer to monitor engine speed. External tachometers draw current and place an additional load on the ignition. Other disadvantages include increases in instrument count, instrument panel size, and instrument wiring, all of which increase overall instrument panel cost. A further disadvantage of using an external tachometer is the increased complexity of the overall system.

Incorporating a tachometer with an annunciator requires the addition of several logic functions including the sequential display of engine speed and fault conditions. The number of components required using digital logic makes the design approach prohibitive. While microprocessor-based annunciators operating at high speeds, such as Frank W. Murphy's S1501, can be programmed to perform the necessary logic and control the display, they draw too much current to be powered from a CD ignition or magnetic pickup. And while microprocessor-based annunciators operating at low speeds, such as Frank W. Murphy's Mark III and that disclosed in U.S. Pat. No. 5,563,456, expressly incorporated herein, draw sufficiently low current, their processing power is too limited to perform the necessary tachometer functions. Recent developments in technology, however, have resulted in peripheral-rich microprocessors that can be operated at low speeds with extremely low current draw and are capable of performing the necessary tachometer and display functions. Such a microprocessor is utilized in the present invention.

2

It is therefore an object of the present invention to provide a microprocessor-based annunciator with an internal tachometer that draws sufficiently low current to be powered from a CD ignition or magnetic pickup. The internal tachometer may advantageously include an overspeed shutdown setpoint and an underspeed shutdown setpoint.

It is a further advantage of the present invention that the internal tachometer can be easily calibrated to match timing pulses from the CD ignition of various engines or magnetic pickup pulses from various flywheels.

It is yet another advantage of the present invention that in addition to monitoring engine speed, it may also monitor engine run hours. U.S. Pat. No. 4,181,883, expressly incorporated herein, discloses an hourmeter-tachometer similar to Frank W. Murphy's SHD30. It is an object of the present invention to provide an annunciator that incorporates the hourmeter-tachometer features of U.S. Pat. No. 4,181,883.

It is yet another advantage of the present invention that it can accommodate normally open or normally closed sensor inputs without requiring hardware or software changes.

It is a still further advantage of the present invention that system information, such as tachometer calibration, overspeed and underspeed setpoints, and engine run hours are stored in nonvolatile memory. This ensures no data is lost, even when backup batteries are replaced.

The system according to the present invention may be implemented using a low power microprocessor programmed to carry out operations corresponding to the components described herein.

Other objects and advantages of the invention will become apparent to those skilled in the art during the course of the following detailed description.

BRIEF DESCRIPTION OF THE DRAWINGS

FIG. 1 shows a simplified block diagram of the annunciator according to the preferred embodiment of the invention.

FIG. 2 shows the user interface, according to the preferred embodiment, comprising a faceplate, keypad and liquid crystal display (LCD).

FIGS. 3A-3D show the LCD displaying different information according to the preferred embodiment.

FIG. 4 shows a schematic diagram of the power supply and shutdown unit according to the preferred embodiment.

FIG. 5 shows a schematic diagram of the sensor input unit according to the preferred embodiment.

FIG. 6 shows a schematic diagram of the microprocessor and logic unit according to the preferred embodiment.

DETAILED DESCRIPTION OF THE
PREFERRED EMBODIMENT

Referring to the drawings in detail wherein like numerals designate like parts, FIG. 1 shows a simplified block diagram of the annunciator according to the preferred embodiment. The Power Supply and Shutdown unit **11** converts the CD Ignition signal **10** into 5 VDC **12** and tach signal **13**, which it sends to the Microprocessor-based Logic Unit **14**. The Microprocessor-based Logic Unit **14** scans the Sensor Input Unit **17** for a fault on one of the Sensor Inputs **16** via the sensor bus **18**. If a fault is detected, the Microprocessor-based Logic unit **14** signals the Power Supply and Shutdown Unit **11** to shut down the engine via the fault shutdown bus **9**, and displays the fault on the LCD **19**. User commands and configuration are input via the User Interface **15**, shown in greater detail in FIG. 2.

The numerous descriptors such as R, D, C, and J shown in FIGS. 4–6 that are not associated with reference numerals simply represent standard nomenclature for the items listed.

Power Supply and Shutdown Unit

FIG. 4 is a schematic diagram of the Power Supply and Shutdown Unit 11 according to the preferred embodiment. CD Ignition signal 10 is first applied to the reverse blocking diode 41, then to the zener diode 42. Zener diode 42 minimizes current draw until CD ignition voltage 10 exceeds its threshold voltage, assisting in engine start up. Once the threshold voltage of zener diode 42 is exceeded, the voltage is applied to regulator circuit 43, which regulates the voltage down to 5 VDC signal 12 which is supplied to Microprocessor-based Logic Unit 14 and Sensor Input Unit 17. When the engine is not running, backup battery 49 supplies power to the Microprocessor-based Logic Unit 14.

Ignition Voltage Detect circuit 44 monitors CD Ignition voltage 10 and detects a drop in voltage below the threshold voltage of zener diode 40, and signals the Microprocessor-based Logic Unit 14 via the Ignition Sense line 45.

Battery Voltage Detect circuit 46 monitors the voltage of backup battery 49 and detects a drop in voltage below the threshold voltage of zener diode 57, and signals the Microprocessor-based Logic Unit 14 via the Battery Sense line 47.

Simple component changes allow the same Power Supply to accept a Magnetic Pickup input as a power source. If Zener Diode 42 is eliminated, the threshold voltage of Zener Diode 40 can be lowered to match the voltage characteristics of a Magnetic Pickup. The Voltage Detect circuit 44 will then monitor the Magnetic Pickup voltage for a drop in voltage below the threshold of zener diode 40.

Independent of power source, the source of the tachometer signal can be either the CD ignition signal 10 or Magnetic pickup signal 58, which is selectable through jumper header 59. If the jumper is placed across pins 3 and 4 of jumper header 59, the ignition signal conditioning circuit 48 filters the ignition signal and supplies the tach signal 13 to the Microprocessor-based Logic Unit 14. If the jumper is placed across pins 1 and 2 of jumper header 59, the magnetic pickup signal conditioning circuit 49 filters the ignition signal and supplies the tach signal 13 to the Microprocessor-based Logic Unit 14.

The Power Supply and Shutdown Unit 11 receives shutdown signals from Microprocessor-based Logic Unit 14 via the Shutdown Bus 9. A high logic level on Ignition Ground Signal 50 turns on Ignition Ground transistor 53, grounding the ignition and shutting down the engine. A high logic level on Fuel Valve Signal 51 turns on Fuel Valve Trip transistor 54, dumping the energy stored in Fuel Valve Trip Capacitor 56, tripping the fuel valve, cutting off fuel to the engine. A high logic level on Alarm Signal 52 turns on Alarm transistor 55, signaling an external alarm device.

Sensor Input Unit

FIG. 5 is a schematic diagram of one half of the Sensor Input Unit 17, each half handling 16 sensor inputs. The number of Sensor Inputs that can be accommodated by the Sensor Input Unit 17 is easily expanded with additional multiplexors. Likewise, the sensor inputs could be run straight into the inputs of the microprocessor 3, eliminating the need for multiplexors. The Sensor Input Unit 17 is scanned by the Microprocessor-based Logic Unit 14 via the Sensor Bus 18.

The Microprocessor-based Logic Unit 14, addresses multiplexor 63 with address lines 62, while pulling Mux Pullup Line 61 high, which applies a voltage to pullup resistors 69. If the addressed sensor input is not faulted, mux output line 64 goes high. If the addressed sensor input is faulted, mux output line 64 goes low, and the Microprocessor-based Logic Unit initiates a shutdown as described below. Current limiting resistors 71 protect the input buffers of multiplexor 63 from high voltage applied at terminal block 67.

Sensors Switches are available in two configurations: Normally Closed and Normally Open. Normally Closed Switch 75 is closed in the normal state, and opens upon reaching a fault condition. Conversely, Normally Open Switch 76 is open in the normal state, and closes upon reaching a fault condition. Manufacturing methods and preferences dictate which configuration is offered. The Sensor Input Unit 17 of the preferred embodiment can handle any combination of normally open or normally closed switches.

Normally closed switch 75 requires two wires run to terminal block 67. While the switch remains closed, mux output line 64 is pulled up through resistors 69. When the switch opens, however, mux output line 64 is pulled low through pull down resistor 73.

Normally open switch 76 requires one wire run to terminal block 67, one wire to ground, and the use of shunt jumper 77 across its input terminals. While the switch remains open, mux output line 64 is pulled up through resistors 69. When the switch closes, mux output line 64 is pulled to ground through the sensor.

Microprocessor-Based Logic Unit

FIG. 6 is a schematic diagram of the Microprocessor-based Logic Unit 14. The microprocessor 3, is programmed to perform the core logic functions of the annunciator: scanning the Sensor Input Unit 17 via Sensor Bus 18, monitoring engine speed, controlling engine shutdown via Shutdown Bus 9, and monitoring the user interface 15. It is critical that microprocessor 3 operate at a low clock frequency to keep the current draw at a minimum. In the preferred embodiment, crystal oscillator 6 has 32.768 kHz frequency, which results in a current draw of approximately 50 microamps for microprocessor 3.

During normal operation, the microprocessor scans the Sensor Input Unit 17 every second, via the Sensor Bus 18, as described above. The microprocessor addresses two multiplexors simultaneously; checking two sensor inputs at a time via Mux Output Lines 64, allowing for faster scan times. Each pair of points is addressed sequentially via Mux Address Lines 62, and the status of each sensor input is stored in the microprocessor's memory. Mux Pullup Line 61 is pulled low after a complete scan to prevent a faulted sensor input from drawing current through pullup resistors 69 on the Sensor Input Unit. Scanning an additional 16 inputs by adding a multiplexor to Sensor Input Unit 17 would require only one additional line into microprocessor 3 for the output of the added multiplexor.

Since microprocessor 3 does not have extensive built in math functions, calculating engine RPM from tach signal 13 presents a problem. If microprocessor 3 were operating at a higher clock speed, math functions capable of calculating RPM from a single period of tach signal 13 could be implemented using basic assembly instructions. But with microprocessor 3 operating at 32.768 kHz, the calculations would take too long considering the other functions that must be performed.

5

To solve this problem, the present invention utilizes a counter and a timer, both peripheral features of microprocessor **3**. The counter, which is capable of counting high speed pulses, is programmed to count pulses from tach signal **13** in the background. The timer is then programmed to generate periodic interrupts, during which the counter is read then reset to zero. If the number of pulses that tach signal **13** produces per engine revolution is known, the period of these interrupts can be calculated so that the number of tach signal pulses counted is equivalent to engine RPM. This ideal interrupt period, or "gate time," T_{gate} , can be calculated using the following equation:

$$T_{gate} = (60 / \text{pulse_per_revolution}) S.$$

Utilizing this method, microprocessor **3** does not have to perform any calculations, it merely reads the counter registers to obtain the engine RPM.

A further problem is presented when utilizing this method, however, if the number of pulses per revolution of tach signal **13** is low. The problem is that the gate time will be too long to provide updated RPM readings of adequate frequency to protect the engine against overspeed. For example, if the pulses per revolution is 6, the interrupt period, $T_{gate} = 60/6$, or 10 seconds. An engine could be destroyed if the engine RPM is out of range for that long a time. The present invention overcomes this problem by conditioning tach signal **13** with phase locked loop circuit **2**. This results in secondary tach signal **4** which is equivalent to tach signal **13** multiplied in frequency by 32. Using secondary tach signal **4** to calculate a gate time (T_{gate}') yields the following equation with the gate time reduced by a factor of 32:

$$T_{gate}' = ((60 / \text{pulse_per_revolution}) / 32) s.$$

Using the same example as above, with pulse per revolution of 6, the new gate time, $T_{gate}' = (60/6)/32$, or 0.3125 seconds, which provides adequate time to respond to an overspeed condition.

Pulses per revolution for a particular engine are entered by the user to calibrate the tachometer. The number of pulses per revolution from a CD ignition system is determined by the following equation:

$$\text{Pulses_Per_Revolution} = \text{Cylinders} / 2 * \text{Engine_Cycles}.$$

The number of pulses per revolution from a magnetic pickup is simply the number of teeth in the ring gear the pickup senses. In the preferred embodiment, pulses per revolution are stored in non-volatile memory **5**, as are overspeed and underspeed setpoints used to trigger shutdowns. Alternatively, battery-backed RAM or dip switches could be used to store pulses per revolution, overspeed and underspeed setpoints, as described in U.S. Pat. No. 4,181,883. Engine RPM is compared to overspeed and underspeed setpoints every 0.5 seconds. If engine RPM is out of range, a shutdown occurs. Numeric codes "50" and "51" are announced to indicate overspeed and underspeed, respectively.

In the preferred embodiment, as long as the annunciator senses the engine is running, an internal hourmeter keeps track of engine run hours. The internal hourmeter utilizes a separate timer, which is also a peripheral feature of the microprocessor, programmed for half second "real time" interrupts and a software counter. Every 720 counts (=360s), the internal hourmeter is incremented $\frac{1}{10}$ hour. The run hours are periodically stored in non-volatile memory **5**.

If the Microprocessor-based Logic Unit **14** senses a Normal Shutdown, as described below, or a fault condition

6

from either the Sensor Inputs, Engine Overspeed, or Engine Underspeed, it shuts the engine down via the Shutdown Bus **9**, as described above.

While running, the Microprocessor-based Logic Unit **14** constantly supplies information to the display **19**, and receives user input from the user interface **15**, as described below.

User Interface and Sequence of Operations

The user interface **15** shown in FIG. 2, comprises a liquid crystal display (LCD) **19**, and membrane switches **20-24**. When the user approaches the annunciator with the engine shutdown, the LCD **19** displays the last fault, as illustrated in FIG. 3A, with the faulted Sensor Number **25** to the left and the status **26** to the right.

To reset the fault, the user presses the RESET button **20**. The LCD **19** then displays the lockout timers, as illustrated in FIG. 3B, with the Timer Number **27** to the left, and the Remaining Time **28**, in seconds, to the right. The lockout timers inhibits user selectable sensor inputs that are engine speed dependent, such as oil pressure, until the engine has come up to speed. All other Sensor Inputs **16**, are scanned at this time. There are 2 independent lockout timers, allowing sensors that take longer to clear to be locked out for different periods. The user may zero out the displayed timer by pressing the Timer "0" button **23**.

Once the lockout timers have expired, all of the Sensor Inputs **16** are scanned. At this time, the LCD **19** displays Engine RPM **29**, as shown in FIG. 3C, continuously until a fault condition occurs or the user presses one of the following buttons: RESET **20**, RUN STOP **21**, TEST **22**, or DISPLAY HOURS **24**.

If the user presses the RESET button **20**, the lockout timers are reinitialized, and will be displayed on the LCD **19**, as shown in FIG. 3B.

If the user presses the RUN STOP button **21**, a normal shutdown will occur, with the ignition grounded and fuel valve tripped, but the alarm is not dropped out. A normal stop is announced by a numeric code "52".

If the TEST button **23** is pressed, a test timer is initiated and displayed. While the test timer is active, all points are inhibited from shutdown, but are displayed on the LCD **19** when faulted, as shown in FIG. 3A, allowing the user to test system operation and wiring. The user may zero the Test Timer by pressing the Timer "0" button **23**, and return to a normal run condition.

If the DISPLAY HOURS button **24** is pressed, the LCD **19** displays the Engine Run Hours **30**, as shown in FIG. 3D, for 5 seconds.

Once a fault shutdown occurs, the alarm is dropped out, the fuel valve is tripped and, after a short delay, the ignition is grounded, shutting down the engine. The delay between tripping the fuel valve and grounding the ignition allows fuel to burn out of the system decreasing the likelihood of backfires on startup. Overspeed and Emergency shutdown conditions bypass this delay, grounding the ignition immediately. Once the engine is shutdown, the LCD **19** displays the fault, as illustrated in FIG. 3A, until the user presses the RESET button **20**, as described above.

In the preferred embodiment, an operator is allowed to enter system information, such as pulses-per-revolution of the engine, overspeed and underspeed setpoints, and timer values, via the keypad. The engine must first be shutdown normally with the RUN-STOP button **21**, as indicated by numeric code "52." After the normal stop, the operator must

press and hold the RUN-STOP button **21** and the Timer-0 button **23** simultaneously for approximately 5 seconds. After that, setup menus prompt the operator to enter system information. All system information entered by the operator is stored in non-volatile memory **5**, which retains the information even if the backup battery **49** is removed.

In the preferred embodiment, a shutdown history is created by storing in non-volatile memory **5** the sensor number of the last 5 shutdowns along with the engine run hours at the time the shutdown occurred.

The preferred embodiment is described by way of illustration. The description of the preferred embodiment is not intended to limit the scope of the claims. One of ordinary skill in the art would recognize that various modifications to the described preferred embodiment may be made without departing from the spirit and [hope] scope of the invention.

We claim:

1. An annunciator for use with an internal combustion engine comprising:

- (a) a sensor input unit in communication with a plurality of parallel connected sensor inputs which change state when a fault condition occurs;
- (b) input means which a human can use to enter information;
- (c) a common display means for sequentially displaying information, such as fault conditions and engine speed;
- (d) a microprocessor-based logic unit which monitors said sensor input unit for a fault condition, monitors said input means for information entered by an operator, sequentially updates said display means, generates shutdown signals in response to said fault conditions, and measures engine speed in response to a tachometer signal, the frequency of which is indicative of the speed of the engine;
- (e) shutdown means responsive to said shutdown signals generated by said microprocessor-based logic unit; said shutdown means being capable of shutting down the engine;
- (f) a power supply which supplies power to said microprocessor-based logic unit and said sensor input unit only [while] *as long as* the engine is running; and
- (g) a backup battery that supplies power to at least said microprocessor-based logic unit [while] *as long as* the engine is not running.

2. The annunciator device according to claim 1, wherein said power supply is a CD ignition power supply.

3. The annunciator device according to claim 1, wherein said power supply is a magnetic pickup power supply.

4. The annunciator device according to claim 1, wherein said microprocessor-based logic unit also measures engine run hours.

5. The annunciator device according to claim 4, wherein said power supply is a CD ignition power supply.

6. The annunciator device according to claim 4, wherein said power supply is a magnetic pickup power supply.

7. An annunciator for use with an engine, comprising:

- (a) a sensor input unit to receive a plurality of sensor inputs;
- (b) a keypad for user input;
- (c) a liquid crystal display (LCD);
- (d) a microprocessor programmed to monitor the sensor input unit for fault conditions indicated by the sensor inputs, generate shutdown signals in response to detecting said fault conditions, monitor the keypad for user input, calculate engine speed in response to a

tachometer signal indicative of a speed of the engine, and display information on the LCD;

(e) output circuitry capable of shutting down the engine in response to the shutdown signals generated by the microprocessor;

(f) a power supply capable of receiving a capacitive discharge CD ignition signal to supply power to the annunciator only while the engine is running; and

(g) a backup battery that supplies power to the annunciator continuously while the engine is not running.

8. The annunciator of claim 7, wherein the LCD comprises a plurality of digits, each comprising seven segments.

9. The annunciator of claim 8, wherein the microprocessor is programmed to, while the engine is not running, display fault codes indicative of the cause of engine shutdown until a user presses a reset button on the keypad.

10. The annunciator of claim 9, wherein one type of fault code is a first number corresponding to an input of the sensor input unit.

11. The annunciator of claim 8, wherein the microprocessor is programmed to monitor engine run hours while the engine is running.

12. The annunciator of claim 11, wherein the microprocessor is programmed to sequentially display, on the LCD, information comprising:

- fault codes;
- engine speed; and
- engine run hours.

13. The annunciator of claim 7, wherein the microprocessor is clocked by a crystal oscillator with a sufficiently low frequency such that the annunciator is capable of being powered from the CD ignition system while the engine is running and continuously from the backup battery while the engine is not running.

14. The annunciator of claim 11, wherein a frequency of the crystal oscillator is approximately 32.768 kilohertz.

15. The annunciator of claim 7, wherein a current draw of the microprocessor is approximately 50 microamperes.

16. The annunciator of claim 7, further comprising non-volatile memory and wherein the microprocessor is programmed to store configuration information in the non-volatile memory.

17. The annunciator of claim 7, wherein the microprocessor is programmed to generate shutdown signals in response to determining a calculated engine speed is equal to or greater than an overspeed setpoint value.

18. The annunciator of claim 17, wherein the microprocessor is programmed to display an overspeed fault code to indicate a calculated engine speed has exceeded the overspeed setpoint value, the overspeed fault code comprising a numeric value greater than a number of inputs of the sensor input unit.

19. The annunciator of claim 17, further comprising a circuit to generate a tachometer signal having a greater frequency than the CD ignition signal.

20. The annunciator of claim 17, wherein the microprocessor is programmed to calculate engine speed by counting pulses from the tachometer signal for a selected gate time.

21. A system for monitoring an engine having a capacitive discharge (CD) ignition system and/or equipment driven by the engine, the system comprising:

- a plurality of sensors; and
- a microprocessor-based annunciator with an internal tachometer in wired communication with the plurality of sensors, the annunciator capable of being powered from the CD ignition system while the engine is running

9

and from a backup battery that supplies power to the annunciator continuously while the engine is not running.

22. The system of claim 21, wherein the plurality of sensors comprises a combination of normally open and normally closed switches.

23. The system of claim 21, wherein:

the annunciator comprises an LCD and a keypad; and the annunciator displays a cause of engine shutdown on the LCD while the engine is not running until a user presses a button on the keypad.

24. The system of claim 23, wherein the LCD comprises a plurality of digits, each comprising seven segments.

25. A method for monitoring an engine with an annunciator, the engine having a CD ignition system, the method comprising:

operating a microprocessor of the annunciator at a sufficiently low frequency such that the annunciator is capable of being powered from the CD ignition system while the engine is running and from a backup battery while the engine is not running;

monitoring a plurality of sensors in wired communication with the annunciator;

calculating a speed of the engine with the microprocessor;

shutting down the engine in response to determining a fault condition; and

displaying a cause of the shutdown on a liquid crystal display (LCD) until a user resets the shutdown.

26. The method of claim 25, wherein the LCD comprises a plurality of digits, each comprising seven segments.

27. The method of claim 26, wherein displaying a cause of the shutdown comprises:

displaying a first number corresponding to a monitored sensor to indicate the cause of shutdown is a faulted sensor; or

displaying a second number higher than the first number to indicate the cause of shutdown other than a faulted sensor.

28. The method of claim 25, wherein operating the microprocessor at a sufficiently low frequency such that the

10

annunciator is capable of being powered from the CD ignition system while the engine is running and from a backup battery while the engine is not running comprises operating the microprocessor at approximately 32.768 kilohertz.

29. The method of claim 25, further comprising monitoring engine run hours while the engine is running.

30. The method of claim 25, further comprising storing engine run hours in non-volatile memory.

31. The method of claim 25, further comprising shutting the engine down in response determining the engine speed is equal to or greater than an overspeed setpoint.

32. The method of claim 31, further comprising multiplying a frequency of a CD ignition signal to generate the tachometer signal.

33. An annunciator for monitoring an engine having a capacitive discharge (CD) ignition system and/or equipment driven by the engine, the annunciator comprising:

an input unit for coupling with a plurality of sensors; and a microprocessor-based logic unit including an internal tachometer function in communication with the input unit, the microprocessor-based logic unit capable of being powered from the CD ignition system as long as the engine is running and from a backup battery as long as the engine is not running.

34. The annunciator of claim 33, wherein the microprocessor-based logic unit is powered continuously from the backup battery as long as the engine is not running.

35. The annunciator of claim 33, wherein the input unit is capable of receiving a plurality of sensors that include a combination of normally open and normally closed switches.

36. The annunciator of claim 33, further comprising an LCD and a keypad, wherein the microprocessor-based logic unit is programmed to display a cause of engine shutdown on the LCD as long as the engine is not running until a user presses a button on the keypad.

37. The system of claim 36, wherein the LCD comprises a plurality of digits, each comprising seven segments.

* * * * *