



US00RE38615E1

(19) **United States**
(12) **Reissued Patent**
Dresden, III et al.

(10) **Patent Number: US RE38,615 E**
(45) **Date of Reissued Patent: Oct. 12, 2004**

(54) **SYSTEM AND METHOD FOR DECREASING RATIO CHANGING TIME IN ELECTRONICALLY ENHANCED POWERTRAIN SYSTEMS**

(75) Inventors: **John Dresden, III**, Farmington Hill, MI (US); **Thomas A. Genise**, Dearborn, MI (US); **Simon Hornby**, Bolton Lancashire (GB); **Ronald K. Markyvech**, Allen Park, MI (US); **Richard A. Nellums**, Farmington Hills, MI (US); **John E. Stainton**, Chorley (GB)

(73) Assignee: **Eaton Corporation**, Cleveland, OH (US)

(21) Appl. No.: **09/640,366**

(22) Filed: **Aug. 16, 2000**

Related U.S. Patent Documents

Reissue of:

(64) Patent No.: **5,655,407**
Issued: **Aug. 12, 1997**
Appl. No.: **08/461,715**
Filed: **Jun. 5, 1995**

(30) **Foreign Application Priority Data**

Jun. 8, 1994 (GB) 9411494

(51) **Int. Cl.⁷** **F16H 59/00**; F16H 61/00; F16D 67/00; B60K 41/02

(52) **U.S. Cl.** **74/336 R**; 477/86; 477/92; 192/222

(58) **Field of Search** 477/92, 94, 86, 477/96, 170, 171, 172; 74/336 R; 192/216, 222

(56) **References Cited**

U.S. PATENT DOCUMENTS

3,548,980 A * 12/1970 Schmidt et al. 477/94
3,834,499 A * 9/1974 Candellero et al. 477/94
4,361,060 A * 11/1982 Smyth

4,544,057 A * 10/1985 Webster et al. 477/86
4,648,290 A * 3/1987 Dunkley et al.
4,785,917 A * 11/1988 Tateno et al. 192/8
4,787,044 A * 11/1988 Nagata et al.
4,933,850 A * 6/1990 Sheeler 477/92
4,961,484 A * 10/1990 Kato et al. 192/3.31
5,053,961 A * 10/1991 Genise
5,053,962 A * 10/1991 Genise
5,121,723 A * 6/1992 Stepper et al. 123/322
5,291,979 A * 3/1994 Iizuka 192/92
5,362,285 A * 11/1994 Sano et al. 477/92
5,393,276 A * 2/1995 White et al. 477/91

FOREIGN PATENT DOCUMENTS

EP 0427000 * 12/1990
EP 0270708 * 5/1991
EP 0638455 * 2/1995
FR 2154235 * 4/1973
GB 2041114 * 9/1980
GB 2182734 * 5/1987

OTHER PUBLICATIONS

SAE Technical Paper Series, Automated Mechanical Transmission Controls, Nov. 7-10, 1983.*
Proc. Instn. Mechn. Engrs., vol. 199, No. D4, A New Concept of Truck Transmission, 1985.*
Truck, pp. 34-41, Mar. 1993.*

(List continued on next page.)

Primary Examiner—Ha Ho

(74) *Attorney, Agent, or Firm*—Kevin M. Hinman; Howard D. Gordon

(57) **ABSTRACT**

A system and method for decreasing the time required to complete a ratio change in an electronically enhanced powertrain system is provided. The powertrain system includes a number of devices for providing a retarding torque to engine rotation to increase the decay rate of the engine speed during an upshift. These devices include an engine brake and an input shaft brake. A retarding torque is also provided by increasing engine accessory load by controlling various engine accessories such as a cooling fan, an air compressor, a hydraulic pump, an air conditioning compressor, and an alternator.

26 Claims, 3 Drawing Sheets

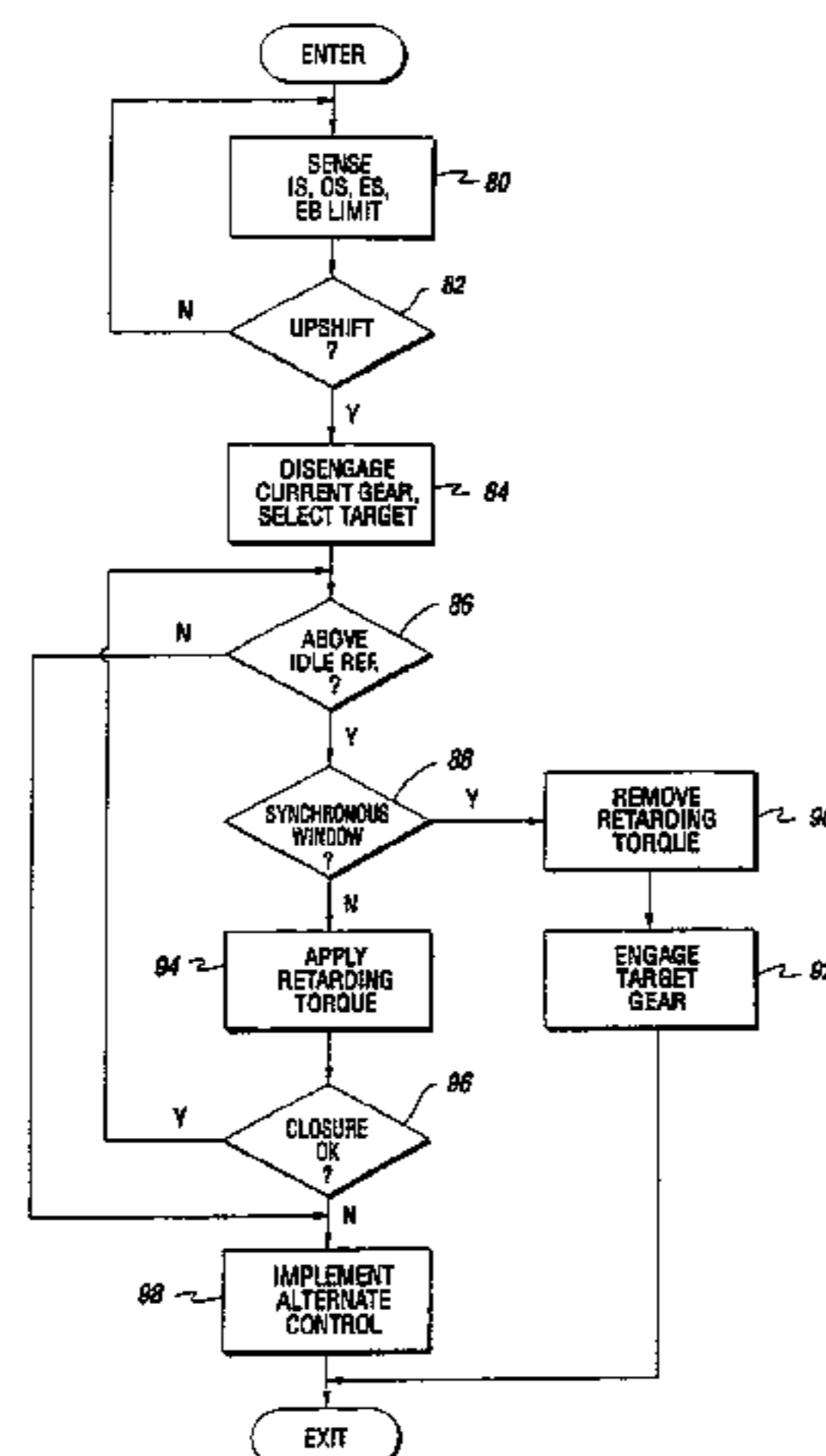

OTHER PUBLICATIONS

Progress On the Drivetrain Electronic Systems of the Japanese Trucks and Buses, Eichi Kato, Hino Motors, Ltd.*

Automated Mechanical Transmission Controls, Hiroshi Yoshimura and Atsushi Hirako, Isuzu Motors Limited, Japan.*

Scania CAG—Computer-Aided Gearshifting, Hal Holmelius, Saab-Scania AB Sweden.*

Commercial Motor, UK Has To Wait For Geartronic Debut, Sep. 26–Oct. 2, 1991, p. 8.*

Commercial Motor, Shifting With More Brains, Sep. 19–25, 1991.*

Powertrain Electronic—Progress On The Use and Development of the Computer Aided Gearshift Systems, Christian Bader, Mercedes-Benz AG, pp. 375–385.*

Electronically Controlled Mechanical Automatic Transmission for Heavy Duty Trucks and Buses, S. Tanaka, F. Moniyama, M. Terasawa, & S. Innami, Hino Motors, Ltd., pp. 161–169.*

* cited by examiner

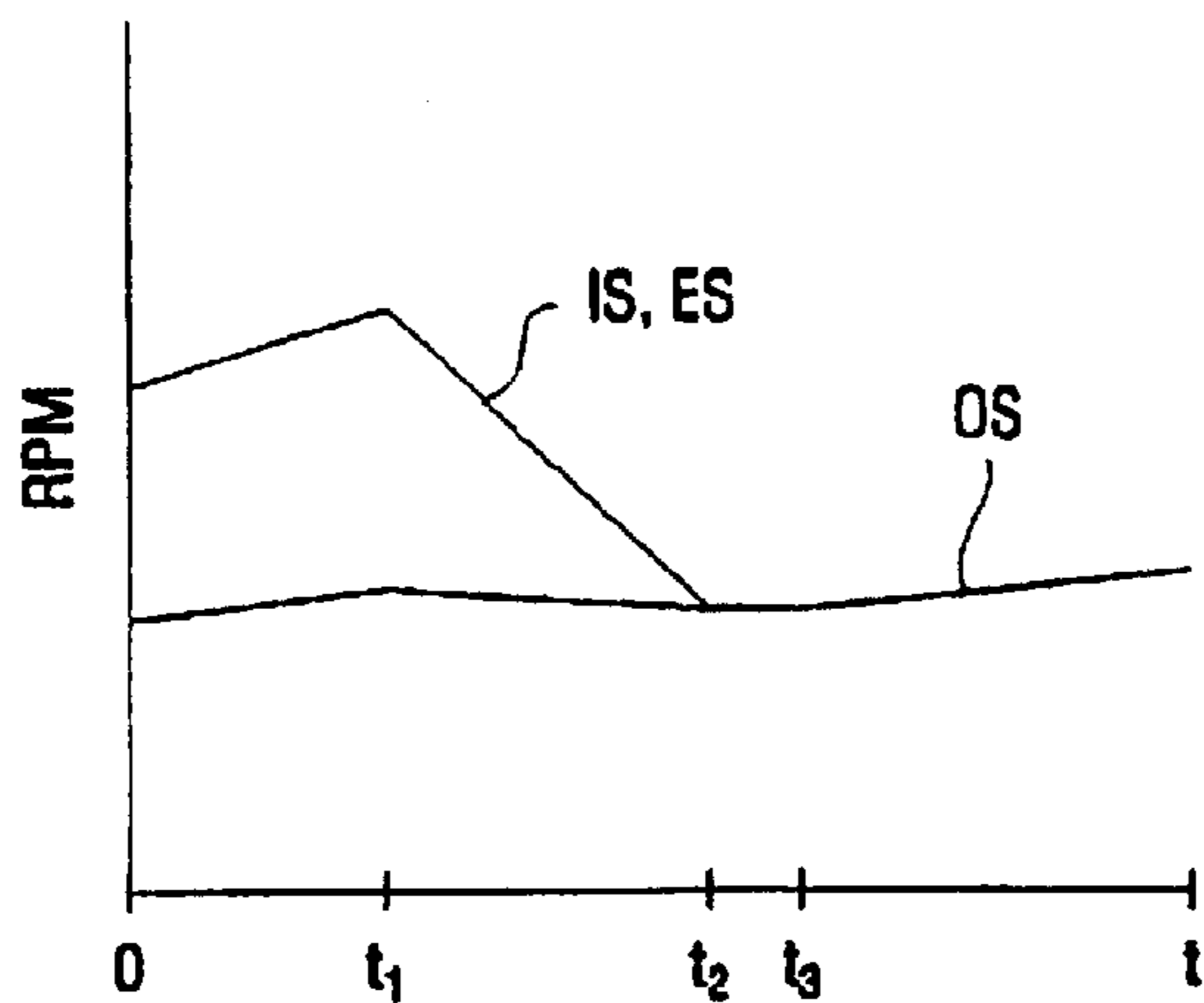

Fig. 2a

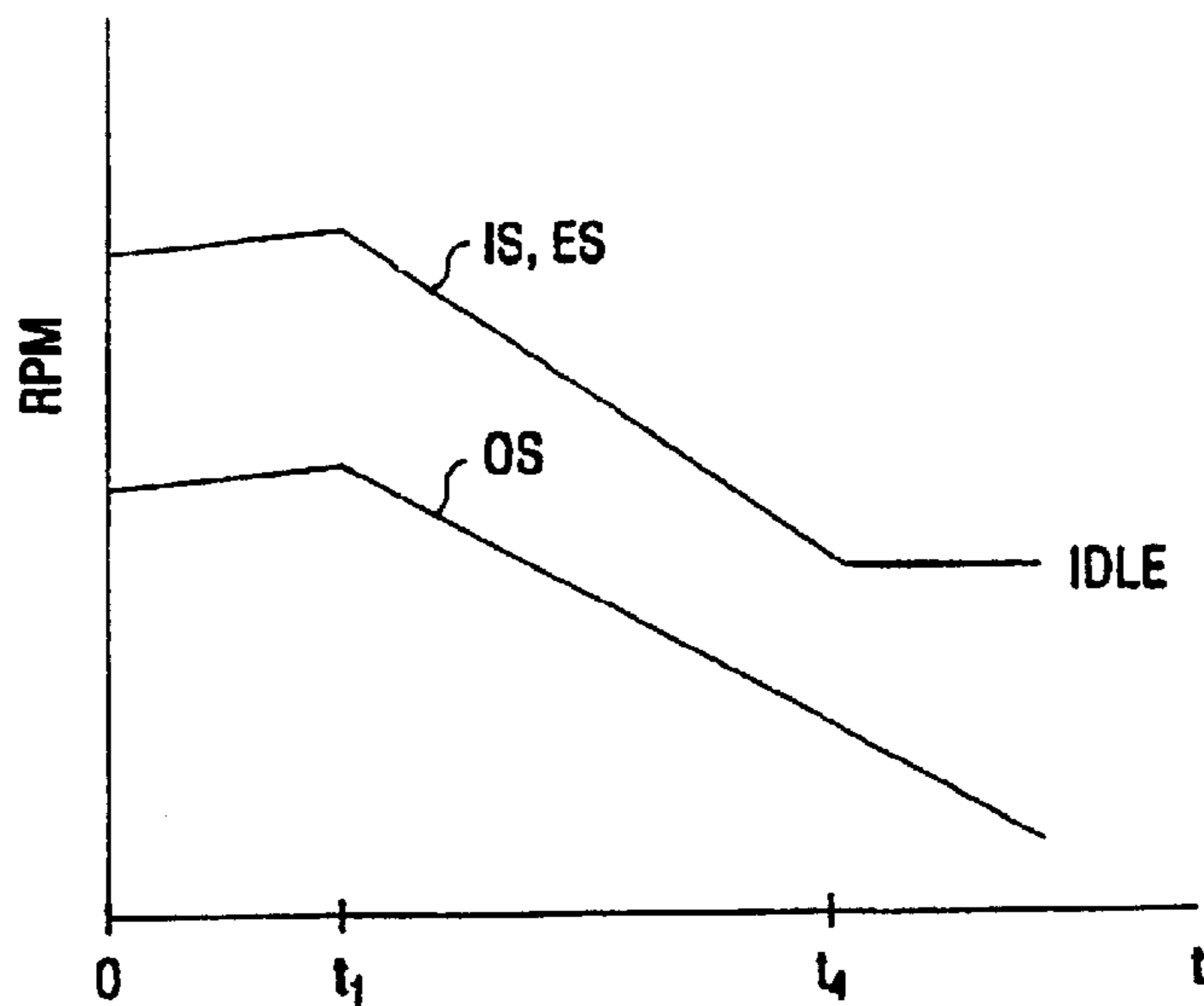

Fig. 2b

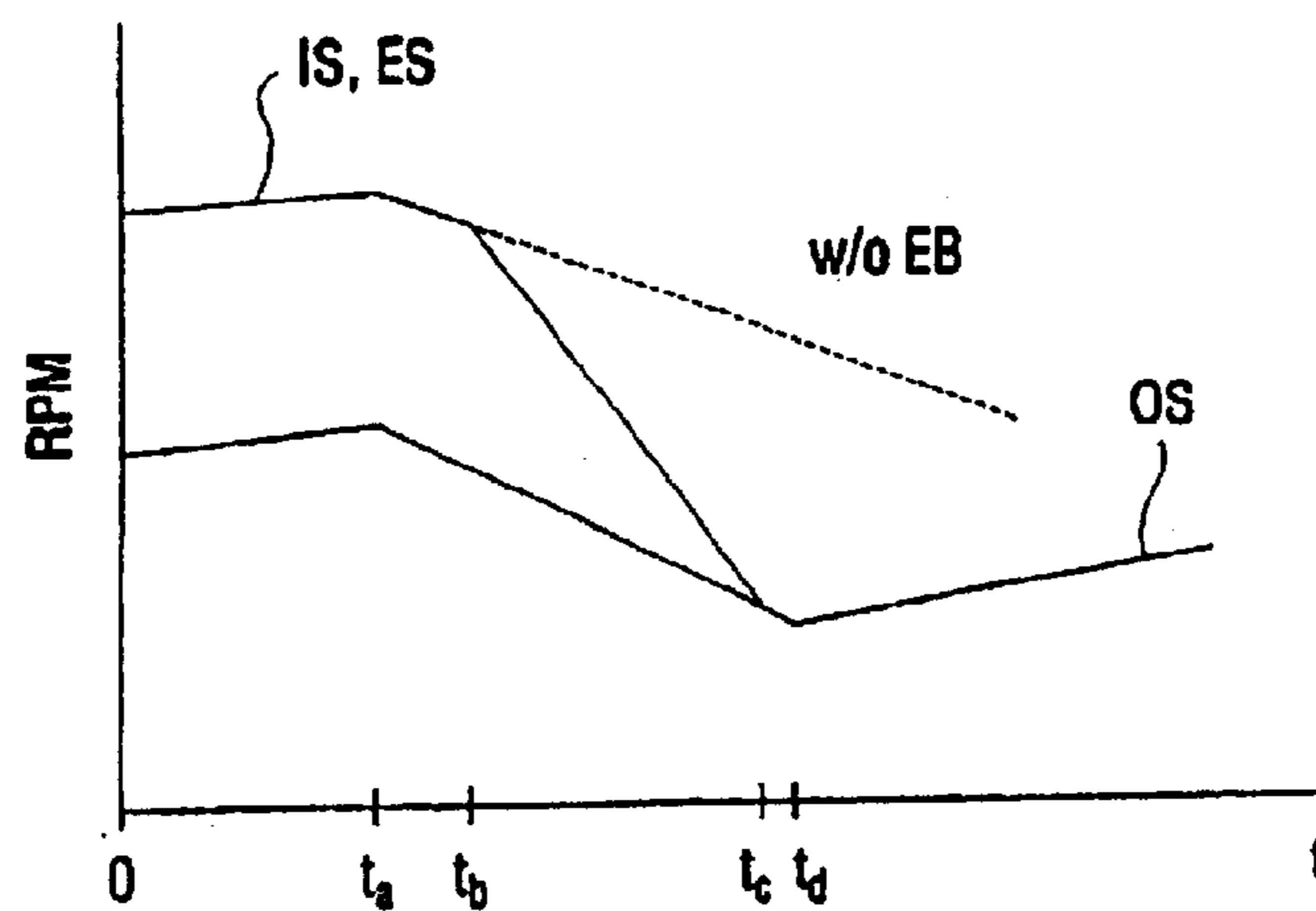

Fig. 2c

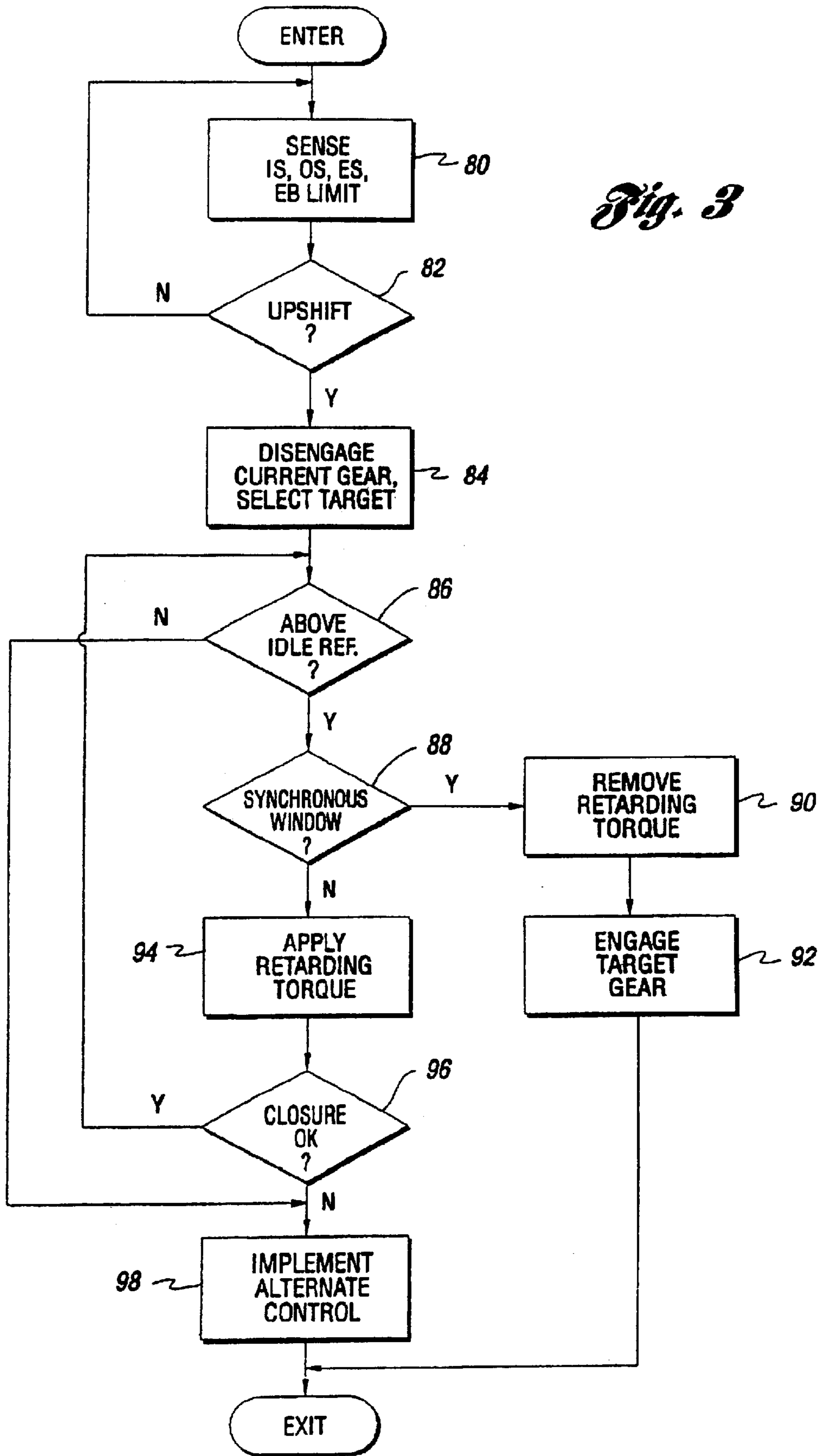

Fig. 3

**SYSTEM AND METHOD FOR DECREASING
RATIO CHANGING TIME IN
ELECTRONICALLY ENHANCED
POWERTRAIN SYSTEMS**

Matter enclosed in heavy brackets [] appears in the original patent but forms no part of this reissue specification; matter printed in italics indicates the additions made by reissue.

RELATED APPLICATIONS

This application is related to copending applications U.S. Ser. No. 08/103,947, filed Aug. 10, 1993, titled CONTROL SYSTEM/METHOD FOR ENGINE BRAKE-ASSISTED SHIFTING and U.S. Ser. No. 08/179,060, filed Jan. 7, 1994, titled ENGINE BRAKE-ENHANCED UPSHIFT CONTROL METHOD/SYSTEM, and assigned to the same assignee, EATON CORPORATION, as this application.

TECHNICAL FIELD

The present invention relates to a system and method for decreasing the time required to complete a ratio change in an electronically enhanced engine and transmission system.

BACKGROUND ART

Electronically enhanced transmission systems have been well developed in the prior art as may be seen by reference to U.S. Pat. Nos. 4,361,060; 4,595,986; 4,648,290; 4,722,248; and 5,050,427, the specifications of which are hereby incorporated by reference in their entirety. Transmission systems such as these have been utilized to provide a variety of gear ratios to enhance the flexibility and torque multiplication of an engine to service a plethora of applications. The most common applications include MVMA Class 7 and Class 8 tractor semi-trailer vehicles although other applications, such as automobile or stationary power plant powertrains, may also be serviced.

Art electronic control module which includes a microprocessor is often used to control the powertrain, which includes an engine as well as a multiple gear ratio transmission. The continuous evolution of microprocessor technology has enabled increased accuracy and expanded the scope of control over engine and transmission operations. The electronic control module collects data from various sensors and issues commands appropriate for the current operating conditions to control the engine and transmission. Engine control may include modulating fuel, operating engine accessories, or managing application of an engine brake or driveline retarder. Transmission control may include selection of an appropriate gear ratio, including disengagement of the current gear ratio and engagement of a new target gear ratio, or operation of an input shaft brake.

Efficient ratio changing improves fuel economy and enhances drivability of a vehicle. Under certain demanding situations, such as when negotiating a steep grade with a heavily loaded vehicle, swift ratio changes are required to prevent the vehicle from losing momentum and missing the window of opportunity to complete the shift entirely. Under normal driving conditions, an operator may have to shift gears more than fifteen times before reaching highway speeds. In these applications, inefficiency in ratio changing may accumulate to a significant amount of wasted time. Thus, it is desirable to reduce the time necessary to complete a ratio change or shift.

A typical ratio change involves a number of steps. First, the operator must interrupt the transfer of torque from the

engine through the transmission to the driveline. This may be accomplished by disengaging a master clutch which provides a frictional coupling between the engine and the transmission. Alternatively, a "throttle dip" may be performed where the throttle is abruptly decreased. Once the torque transfer has been interrupted, the current gear is disengaged and the transmission is in a neutral state.

The next step in a typical ratio change involves selecting the target gear ratio. This may be the next available gear ratio in the sequence, or a number of available ratios may be skipped, depending on the current operating conditions. Before engaging the target gear, the transmission input shaft should rotate at a substantially synchronous speed for the current output shaft speed and target gear ratio. When the master clutch is engaged, the input shaft speed may be controlled by controlling engine speed since the engine and transmission are coupled. Engine speed may be increased (for a downshift) or decreased (for an upshift) to realize synchronous speed. On transmissions equipped with an input shaft brake, the input shaft speed may be reduced by disengaging the master clutch and applying the input shaft brake (also known as an inertia brake or clutch brake). However, input shaft brakes with sufficient capacity to decrease ratio changing time add cost and complexity to the transmission system and require accurate sequencing of events for satisfactory operation, so many transmissions only utilize simple versions of these devices.

For transmissions without input shaft brakes, synchronous speed will not be attained with the master clutch engaged on an upshift until the engine speed naturally decays to synchronous. As engines become more and more efficient, the reduction of internal frictional losses results in a substantially lower natural engine decay rate. This results in a correspondingly longer time to complete a ratio change. Thus, it is desirable to increase engine deceleration during an upshift to achieve synchronous speed shortly after disengagement of the current gear.

A device often utilized to provide a variable retarding force to an engine, is an engine brake. The most common engine brakes may be either engine compression brakes or exhaust brakes. These devices are well known in the prior art and are commonly provided on heavy-duty vehicles. Examples of vehicular automated mechanical transmission systems utilizing engine brakes may be seen by reference to U.S. Pat. Nos. 4,933,850 and 5,042,327 the specifications of which are hereby incorporated by reference in their entirety.

Engine compression brakes are usually manually operated and provide a variable retarding force resisting engine rotation by altering valve timing of one, two, or three banks of cylinders. This creates compressive force within the cylinders which resists rotation of the crankshaft. Exhaust brakes operate in a similar fashion by restricting exhaust flow from the engine. Exhaust brakes do not offer the responsiveness or flexibility of engine compression brakes although they are less expensive to employ.

Traditionally, engine brakes are utilized to assist the vehicle service brakes by supplying a resisting torque on the driveline when descending long grades. Manual operation of the engine brake in these situations continues to be a desirable option. More recently, engine brakes have been manually operated to decrease the time required for ratio changes. For this application, manual operation of the engine brake often results in large torque disturbances to the vehicle driveline due to inappropriate timing in applying and releasing the engine brake. This reduces drivability of the vehicle and may also adversely affect the durability of

3

powertrain components. Furthermore, proper operation is largely dependent upon the skill and experience of the vehicle operator.

SUMMARY OF THE INVENTION

It is, therefore, an object of the present invention to provide a system and method for reducing the time required to complete a ratio change, in particular, an upshift ratio change, in a manual, semi-automatic or fully automatic transmission.

It is an additional object of the present invention to provide a system which reduces the time required to achieve synchronous speed by increasing a retarding force acting on engine rotation.

Another object of the present invention is to provide a system which automates control of an engine compression brake to decrease ratio changing time in a manual, semi-automatic or fully automatic transmission.

A still further object of the present invention is to provide a system which increases engine load to supply a variable retarding force so as to improve ratio changing times in a manual, semi-automatic or fully automatic transmission.

Yet another object of the present invention is to provide a system which reduces driveline disturbances during an upshift by utilizing an engine brake when a transmission neutral condition is sensed.

In carrying out the above object and other objects and features of the present invention, a control system is provided for reducing the ratio changing time of a mechanical transmission system. The transmission system includes an engine selectively coupled by a master friction clutch to a mechanical change gear transmission. The system also includes an electronic control unit for receiving a plurality of input signals indicative of an engine speed, an output shaft speed, and a neutral gear state of the transmission. The electronic control unit also generates command signals for controlling the engine and the transmission. The transmission includes a plurality of gear ratio combinations, and a neutral gear state, selectively engageable between a transmission input shaft and a transmission output shaft. The control system utilizes a sensor for sensing the neutral gear state which occurs after disengaging a current gear ratio and before effecting a target gear ratio in the transmission. The system also includes devices for applying a retarding torque to the engine in response to a command from the electronic control unit. The retarding torque is applied to the engine while the engine speed is above the synchronous speed at which the target gear ratio is effected, so as to increase engine deceleration and reduce ratio changing time. A method is also provided for use with the system and similar systems.

The above objects and other objects, features, and advantages of the present invention will be readily appreciated by one of ordinary skill in the art from the following detailed description of the best mode for carrying out the invention when taken in connection with the accompanying drawings.

BRIEF DESCRIPTION OF THE DRAWINGS

FIG. 1 is a schematic representation of a powertrain system including a mechanical transmission and an engine brake according to the present invention;

FIG. 2a is a graphical representation of a typical upshift with a master friction clutch engaged, unassisted by an engine brake;

FIG. 2b is a graphical representation of an attempted upshift under demanding conditions without utilizing an engine brake;

4

FIG. 2c is a graphical representation of an engine brake assisted upshift with a master friction clutch engaged according to the present invention; and

FIG. 3 is a flow chart illustrating the method of reducing ratio changing times according to the present invention;

BEST MODE FOR CARRYING OUT THE INVENTION

FIG. 1 schematically depicts a vehicular powertrain system, indicated generally by reference numeral 10. The system includes an internal combustion engine 12 which is selectively coupled to the input shaft 14 of a multiple gear change transmission 16 via a master friction clutch 18. Engine 12 may be any of a number of types of internal combustion engines, such as a diesel engine or a gasoline engine. Master friction clutch 18 includes driving elements 20 which are attached to the crankshaft 22 of engine 12, and driven elements 24 which are attached to input shaft 14. When master friction clutch 18 is engaged, substantially all the torque delivered by engine 12 is transmitted through driving elements 20 and driven elements 24 to transmission 16.

Output shaft 26 of transmission 16 is adapted to engage an appropriate driveline component (not specifically illustrated), such as a differential, drive axle, transfer case, or the like. Powertrain system 10 may also include a heat exchanger 28, such as a conventional radiator, an electrically controllable cooling fan 30, and an engine brake 32. Other components may include a hydraulic pump for power steering or other oil operated devices, an air conditioned compressor for cab climate control, an alternator for supplying electrical power, and an air compressor 34 and a compressed air storage tank 36 for powering pneumatically actuated devices or systems, such as the transmission input shaft brake 38, or the vehicle service brakes (not specifically illustrated).

Powertrain system 10 includes a number of sensors and actuators to effect control of the system as determined by the electronic control unit (ECU) 40. The various sensors provide information indicative of the current operating conditions to ECU 40 via input means 42. ECU 40 utilizes this information in executing a predetermined set of instructions, stored in a memory, to generate command signals. The command signals are relayed to the various actuators via output means 44.

Some representative sensors in communication with ECU 40 include a crankshaft sensor 46 for indicating engine speed (ES), an input speed sensor 48 for indicating transmission input speed (IS), and an output shaft sensor 50 for indicating transmission output speed (OS). Other sensors include a throttle position sensor 52 for indicating the position of throttle pedal 54, a brake-applied sensor 58 to indicate the state of service brake pedal 56 for applying the vehicle service brakes, and a gear selection indicator 60 for selecting a reverse (R), neutral (N), or drive (D) gear of transmission 16. In some applications, an additional gear selector is provided to indicate a request for an upshift or downshift. A manual engine brake selector 62 is provided for allowing manual control of the engine brake under certain operating conditions, as described below.

Powertrain system 10 also includes a number of actuators in communication with ECU 40. The actuators receive commands from ECU 40 via output means 44. Preferably, a standard communications link, such as the SAE J1922 or SAE J1939, is utilized for the actuators and sensors. The actuators may also provide feedback to ECU 40 via input

means **42** to effect a closed-loop control system. Typical actuators include a fuel controller **70** for regulating the amount of fuel delivered to engine **12**, and a clutch operator **72** for engaging and disengaging master friction clutch **18**. Commands from ECU **40** may also be directed to actuators through other controllers. For example, fuel controller **70** may be responsible for activating engine brake **32** upon request by ECU **40**. Transmission operator **74** is operative to change the gear ratio of transmission **16** to achieve a selected gear. Transmission operator **74** also provides a signal indicative of the currently engaged gear or a neutral gear state of transmission **16**.

Any of a number of known sensor types may be utilized to provide information related to the current operating conditions to ECU **40** without departing from the spirit or the scope of the present invention. Similarly, known electric, hydraulic, pneumatic, and combination actuators may be implemented to realize the present invention. Transmission system controls and actuators of the type described above may be appreciated in greater detail by reference to U.S. Pat. Nos. 4,959,986; 4,576,065; and 4,445,393, the specifications of which are hereby incorporated by reference in their entirety.

A better understanding of the operation of the present invention will be facilitated by reference to FIGS. **2a** through **2c** which are graphical representations of various component rotational speeds during three different upshifts.

FIG. **2a** is a graphical representation of an upshift performed by powertrain system **10** of FIG. **1** with master friction clutch **18** engaged and without utilizing engine brake **32**. The upshift begins at time t_1 where the current gear is disengaged so that transmission **16** is in a neutral gear state as indicated by transmission operator **74** or by a comparison of transmission input and output speeds. Also at time t_1 , the engine is defuelled by fuel controller **70**. Since master friction clutch **18** is still engaged, input shaft **14** is coupled to crankshaft **22** and engine speed (ES) is equal to input speed (IS). As illustrated, ES (and IS) decreases until achieving synchronous with output shaft speed (OS) at time t_2 (illustrations assume a target gear ratio of 1.00). Synchronous speed is achieved when $IS=OS * GR_T$, where GR_T is the target gear ratio.

Since engine brake **32** is not being used, the rate at which ES decreases is the natural decay rate of the system. The natural decay rate is a function of the rotational inertia of the rotating engine, clutch, and transmission components. Also near time t_2 , when ES is within approximately 40 RPM of synchronous, transmission operator **74** engages the selected target gear. At time t_3 , fuel is restored to engine **12** by fuel controller **70** and the upshift has been completed.

In FIG. **2b**, a graphical representation of an attempted upshift under demanding conditions, such as when ascending a steep grade, is shown. Similar to the event illustrated in FIG. **2a**, at time t_1 , transmission operator **74** disengages the current gear and indicates a neutral gear state to ECU **40** while engine **12** is defuelled by fuel controller **70**. Without engine fueling, the vehicle slows down rapidly, causing OS to decrease. The natural decay rate of engine **12** is too gradual to attain synchronous before reaching engine idle speed at time t_4 . Thus, the window of opportunity to complete the desired upshift has passed and the upshift must be aborted.

FIG. **2c** is a graphical representation of an upshift performed by powertrain system **10** with master friction clutch **18** engaged while also utilizing engine brake **32**. At time t_a , the current gear is disengaged, engine **12** is defuelled, and

ES begins to decrease at its natural decay rate. ECU **40** generates a command signal to apply engine brake **32** when a neutral gear state is indicated by transmission operator **74** at time t_b . Engine brake **32** is operative to increase the decay rate of ES such that synchronous speed may be attained at time t_c . The target gear is engaged at time t_c by transmission operator **74** in response to a command signal from ECU **40**. Power to engine **12** is restored at time t_d as fuel controller **70** increases the delivered fuel in response to a command from ECU **40**, thereby completing the upshift. Of course, transmission gear disengagement and engagement could remain under control of the vehicle operator, and still be within the scope of the present invention. In the case of manual control of gear engagement, at time T_c fuel controller **70** would operate to maintain ES and IS at synchronous speed until transmission operator **74** indicated that the target gear had been manually engaged.

As illustrated in FIG. **1**, engine brake **32** is in communication with engine brake selector **62**, which provides for manual operation of engine brake **32** when descending a long grade. Typically, the engine brake is actuated when ES is above idle and throttle pedal **54** is fully released. Engine brake selector **62** could also be arranged to allow driver selection of the level of retardation to be provided during an upshift, so that zero, one, two or three banks of cylinders are activated when signaled by ECU **40**. Engine brake activation could also be limited to multiple ratio upshifts only, or only when the required engine speed decay rate for an acceptable upshift exceeds a given threshold. These techniques minimize the wear and tear resulting from engine brake use.

As previously discussed, an engine brake may be either a compression brake or an exhaust brake. In addition to conventional engine brakes, the present invention controls engine accessories to effect a modified form of engine braking. By selectively energizing and de-energizing accessories such as cooling fan **30**, air compressor **34**, or other devices (not shown) such as hydraulic pumps, air conditioning compressors, or alternators, the load on engine **12** may be increased or decreased, respectively, so as to vary the engine speed decay rate. Furthermore, an input shaft brake **38** under control of ECU **40** may be applied with the master clutch engaged to supply an additional retarding force operative to increase the decay rate of engine **12**. Of course, any combination of the above devices, or other similar devices such as a driveline retarder, may be used together to produce a variable retarding force depending upon the particular system operating conditions.

Since various engine braking devices, such as an engine compression brake, take a significant time to respond relative to the total time required for an upshift, these devices may be actuated prior to sensing a neutral gear state. For example, in FIG. **2c**, the engine brake would be actuated before time t_a to reduce or eliminate the time lapse between time t_a and time t_b . The exact actuation time would depend upon the response time of the particular braking device being utilized and the details of the arrangements to ensure that the current gear will be disengaged. This strategy works particularly well with engines which revert to idle fuelling when the engine brake is activated. Reverting to idle fuelling accomplishes the throttle dip function which interrupts torque transfer through the transmission to allow disengagement of the current gear.

Engine brake response time is also considered in determining when to deactivate the engine brake. The present invention deactivates the engine brake at an appropriate time to anticipate a natural engine speed decay rate when ES will be within the synchronous window, i.e. within about 40 RPM of synchronous speed.

If the target speed for IS is below a reference value such as 200 RPM above engine idle speed, alternative synchronization methods must be implemented, such as disengaging the master clutch and actuating an input shaft brake. One situation where this occurs is in completing a stationary shift since OS is near zero so synchronous speed is below the engine idle reference speed.

The present invention also provides for various contingencies to accommodate diverse operating conditions. If the engine brake engages prior to its predicted engagement (due to a varying response time), clutch operator 72 may disengage master friction clutch 18 while the current gear is being disengaged so the shift may progress acceptably. Other alternative control sequences are initiated by ECU 40 in the event that synchronization is not being accomplished, as in the case illustrated in FIG. 2b. For example, engine braking may be increased by using a combination of conventional engine braking with engine accessory loading and application of input shaft brake 38.

Typically, input shaft brakes are utilized to decelerate the input shaft of a transmission when the master friction clutch is disengaged. Thus, traditional input shaft brakes are designed to decelerate a limited rotational inertia. Therefore, utilizing input shaft brake 38 according to the present invention may require a high-capacity input shaft brake 38 to accommodate the rotational inertia generated by engine 12, crankshaft 22, and master friction clutch 18 so that input shaft brake 38 may be applied while master friction clutch 18 is still engaged.

FIG. 3 is a flowchart illustrating the method of decreasing ratio changing times according to the present invention. At step 80, the ECU gathers information from the various sensors and actuators of the system and obtains values for ES, IS, OS, and a limiting value for engine braking. If an upshift has been requested by the operator, or is indicated by the ECU, step 82 directs processing to continue with step 84. Otherwise, the process loops back to step 80.

As also shown in FIG. 3, step 84 includes disengaging the current gear and selecting an appropriate target gear. Once the current gear is disengaged, the transmission is in a neutral gear state. If ES is above an idle reference value, as determined by step 86, then a test is performed to determine if engine speed is within the synchronous window step 88. Otherwise, if ES is below idle speed, alternate control strategies are initiated by step 98 which include those contingencies discussed above. If a speed within the synchronous window has not been attained, a retarding torque is applied as indicated by step 94. This may include activating an engine compression brake, increasing engine accessory load, or a combination of these as previously discussed.

Still referring to FIG. 3, the closure rate between ES and synchronous speed is examined at step 96. If the closure rate is satisfactory for current operating conditions, the process continues with step 86. Otherwise, alternate control strategies are implemented by step 98. Once the synchronous speed window is attained as determined by step 88, the retarding torque is removed at step 90 and the target gear is engaged at step 92 so as to complete the upshift.

It is understood, of course, that while the form of the invention herein shown and described constitutes a preferred embodiment of the invention, it is not intended to illustrate all possible forms thereof. It will also be understood that the words used are descriptive rather than limiting, and that various changes may be made without departing from the spirit or scope of the invention as claimed below.

What is claimed is:

1. A method for reducing a ratio changing time in a mechanical powertrain system including an engine having a device operative to retard engine rotation, the engine being coupled by a master friction clutch to a mechanical change gear transmission having a plurality of gear ratio combinations and a neutral gear state selectively engageable between a transmission input shaft and a transmission output shaft, the system also including an electronic control unit for receiving a plurality of input signals indicative of an engine speed, an output shaft speed, and a neutral gear state, the electronic control unit also being operative to generate command signals for controlling the engine retarding device, the method comprising:

sensing the neutral gear state which occurs after disengaging a current gear ratio and before effecting engagement of a target gear ratio; [and]

while the master friction clutch is engaged, applying a retarding torque to the engine while the engine speed is above a synchronous speed at which engagement of the target gear ratio is effected so as to increase engine deceleration and reduce ratio changing time;

monitoring the closure rate at which engine speed approaches the synchronous speed; and

controlling application of the retarding torque based on the closure rate.

2. The method of claim 1 wherein the transmission further includes an input shaft brake for retarding rotation of the input shaft and wherein applying a retarding torque comprises actuating the engine retarding device in combination with actuating the input shaft brake.

3. The method of claim 2 wherein the engine retarding device is an engine compression brake.

4. The method of claim 1 wherein the transmission system further includes a plurality of engine accessories coupled to the engine and in communication with the electronic control unit and wherein applying a retarding torque comprises energizing at least one of the plurality of engine accessories to increase engine load.

5. The method of claim 4 wherein the engine accessories include a cooling fan, an air compressor, a hydraulic pump, an air conditioning compressor, and an alternator.

6. The method of claim 1 wherein the transmission system further includes a plurality of engine accessories coupled to the engine and in communication with the electronic control unit, the transmission further includes an input shaft brake for retarding rotation of the input shaft, and wherein applying a retarding torque comprises actuating a combination of devices selected from the group consisting of the plurality of engine accessories, the engine retarding device, and the input shaft brake.

[7. The method of claim 1 further comprising:

monitoring the closure rate at which the engine speed approaches the synchronous speed; and

controlling application of the retarding torque based on the closure rate.]

8. The method of claim [7] 1 wherein controlling application of the retarding torque includes increasing the retarding torque.

9. The method of claim [7] 1 wherein monitoring the closure rate includes determining if the engine speed is above an engine idle reference speed.

10. A control system for reducing a ratio changing time of a mechanical powertrain system including an engine coupled to a mechanical change gear transmission having a plurality of gear ratio combinations and a neutral gear state

selectively engageable between a transmission input shaft and a transmission output shaft, the powertrain system also including an electronic control unit for receiving a plurality of input signals indicative of an engine speed, an output shaft speed, and a neutral gear state, the electronic control unit also being operative to generate command signals for controlling the engine and the transmission, the control system comprising:

means for applying a retarding torque in response to a command from the electronic control unit, the retarding torque being applied to the engine while the engine speed is above a synchronous speed at which the target gear ratio is effected so as to increase engine deceleration and reduce ratio changing time;

means for monitoring the closure rate at which the engine speed approaches the synchronous speed; and

means for controlling application of the retarding torque based on the closure rate.

11. The control system of claim 10 wherein the means for applying a retarding torque comprises an input shaft brake attached to the transmission and in communication with the electronic control unit for retarding rotation of the input shaft.

12. The control system of claim 10 wherein the means for applying a retarding torque comprises an engine brake.

13. The control system of claim 12 wherein the engine brake is an engine compression brake.

14. The system of claim 10 wherein the means for applying a retarding torque comprises a plurality of engine accessories coupled to the engine for increasing a load on the engine so as to retard engine rotation.

15. The system of claim 10 wherein the means for applying a retarding torque comprises an engine cooling fan for increasing a load on the engine so as to retard engine rotation.

16. The system of claim 15 wherein the means for applying a retarding torque further comprises an air compressor, a hydraulic pump, an air conditioning compressor, and an alternator, all of which are coupled to the engine for increasing a load on the engine so as to retard engine rotation.

17. The system of claim 10 wherein the means for monitoring the closure rate includes means for determining if the engine speed is above an engine idle reference speed.

18. The method of claim 1 wherein the transmission further includes an input shaft brake for retarding rotation of the input shaft and wherein the step of applying a retarding torque comprises actuating the input shaft brake.

19. A method for reducing a ratio changing time in a mechanical powertrain system including an engine having a device operative to retard engine rotation, the engine being coupled by a master friction clutch to a mechanical change-gear transmission having a plurality of gear ratio combinations and a neutral gear state selectively engageable between a transmission input shaft and a transmission output shaft, the system also including an electronic control unit for receiving a plurality of input signals indicative of an engine speed, an output shaft speed, and a neutral gear state, the electronic control unit also being operative to generate command signals for controlling the engine retarding device, the method comprising:

sensing the neutral gear state which occurs after disengaging a current gear ratio and before effecting engagement of a target gear ratio;

determining a first value indicative of one of (i) a current engine speed and (ii) an expected engine speed;

determining a second value indicative of one of (i) a current synchronous speed for engaging said target ratio and (ii) an expected synchronous speed for engaging said target ratio;

determining a difference between said first and second values; and

while the master friction clutch is engaged, generating command signals to said engine retarding device for applying a retarding torque to the engine while the engine speed is above a synchronous speed at which engagement of the target gear ratio is effective so as to increase engine deceleration and reduce ratio changing time, said engine retarding device controlled in accordance with at least one of (i) said difference and (ii) a rate of change of said difference.

20. The method of claim 19 wherein, if said difference is less than about 40 RPM, then the engine retarding device is not activated.

21. The method of claim 19, wherein said engine retarding device has a determined reaction time, and said engine retarding device is controlled based upon said reaction time.

22. A method for reducing a ratio changing time in a mechanical powertrain system including an engine having a device operative to retard engine rotation, the engine being coupled by a master friction clutch to a mechanical change-gear transmission having a plurality of gear ratio combinations and a neutral gear state selectively engageable between a transmission input shaft and a transmission output shaft, the system also including an electronic control unit for receiving a plurality of input signals indicative of an engine speed, an output shaft speed, and a neutral gear state, the electronic control unit also being operative to generate command signals for controlling the engine retarding device, the method comprising:

sensing the neutral gear state which occurs after disengaging a current gear ratio and before effecting engagement of a target gear ratio;

determining a value indicative of an engine speed;

determining a synchronous window of engine speeds for engaging said target gear ratio; and

while the master friction clutch is engaged, generating command signals to said engage retarding device for applying a retarding torque to the engine while the engine speed is above a synchronous speed at which engagement of the target gear ratio is effective so as to increase engine deceleration and reduce ratio changing time, said engine retarding device controlled in accordance with said value and said synchronous window.

23. The method of claim 22 wherein said engine retarding device has a determined reaction time, and said engine retarding device is controlled based upon said reaction time.

24. A method for reducing a ratio changing time in a mechanical powertrain system including an engine having a device operative to retard engine rotation, the engine being coupled by a master friction clutch to a mechanical change-gear transmission having a plurality of gear ratio combinations and a neutral gear state selectively engageable between a transmission input shaft and a transmission output shaft, the system also including an electronic control unit for receiving a plurality of input signals indicative of an engine speed, an output shaft speed, and a neutral gear state, the electronic control unit also being operative to generate command signals for controlling the engine retarding device, the method comprising:

sensing the neutral gear state which occurs after disengaging a current gear ratio and before effecting engagement of a target gear ratio;

11

determining a rate of engine speed decay required for synchronous engagement of said target ratio;

comparing said rate to a reference value; and

only if said rate exceeds said reference value, while master friction clutch is engaged, applying a retarding torque to the engine while the engine speed is above a synchronous speed at which engagement of the target gear ratio is effective so as to increase engine deceleration and reduce ratio changing time.

25. A method for reducing a ratio changing time in a mechanical powertrain system including an engine having a device operative to retard engine rotation, the engine being coupled by a master friction clutch to a mechanical change-gear transmission having a plurality of gear ratio combinations and a neutral gear state selectively engageable between a transmission input shaft and a transmission output shaft, the system also including an electronic control unit for receiving a plurality of input signals indicative of an engine speed, an output shaft speed, and a neutral gear state, the electronic control unit also being operative to generate command signals for controlling the engine retarding device, the method comprising:

determining a value indicative of a natural engine speed decay rate;

sensing the neutral gear state which occurs after disengaging a current gear ratio and before effecting engagement of a target gear ratio; and

while the master friction clutch is engaged, generating command signals to said engine retarding device for applying a retarding torque to the engine while the engine speed is above a synchronous speed at which engagement of the target gear ratio is effective so as to increase engine deceleration and reduce ratio chang-

12

ing time, said engine retarding device controlled in accordance with said value.

26. A method for reducing a ratio changing time in a mechanical powertrain system including an engine having a device operative to retard engine rotation, the engine being coupled by a master friction clutch to a mechanical change-gear transmission having a plurality of gear ratio combinations and a neutral gear state selectively engageable between a transmission input shaft and a transmission output shaft, the system also including an electronic control unit for receiving a plurality of input signals indicative of an engine speed, an output shaft speed, and a neutral gear state, the electronic control unit also being operative to generate command signals for controlling the engine retarding device, the method comprising:

sensing the neutral gear state which occurs after disengaging a current gear ratio and before effecting engagement of a target gear ratio; and

determining if engaging said target gear ratio involves a multiple ratio upshift; and

while the master friction clutch is engaged, generating command signals to said engine retarding device for applying a retarding torque to the engine while the engine speed is above a synchronous speed at which engagement of the target gear ratio is effective so as to increase engine deceleration and reduce ratio changing time, said engine retarding device controlled in accordance with said determination.

27. The method of claim 26 wherein said engine retarding device is activated only during multiple ratio upshifts.

* * * * *