



US00RE38153E

(19) **United States**
(12) **Reissued Patent**
Finarov

(10) **Patent Number:** **US RE38,153 E**
(45) **Date of Reissued Patent:** **Jun. 24, 2003**

(54) **TWO-DIMENSIONAL BEAM DEFLECTOR**

(75) Inventor: **Moshe Finarov, Rehovot (IL)**

(73) Assignee: **Nova Measuring Instruments, Ltd., Rehovot (IL)**

(*) Notice: This patent is subject to a terminal disclaimer.

(21) Appl. No.: **09/557,938**

(22) Filed: **Apr. 24, 2000**

Related U.S. Patent Documents

Reissue of:

(64) Patent No.: **5,764,365**
Issued: **Jun. 9, 1998**
Appl. No.: **08/645,346**
Filed: **May 13, 1996**

U.S. Applications:

(

(63) Continuation-in-part of application No. 08/221,724, filed on Apr. 1, 1994, now Pat. No. 5,517,312.

(30) **Foreign Application Priority Data**

Nov. 9, 1993 (IL) 107549

(51) **Int. Cl.**⁷ **G01B 11/06; G02B 26/08**

(52) **U.S. Cl.** **356/630; 356/369; 359/202**

(58) **Field of Search** 356/128, 369, 356/381, 382, 364-368, 237.1, 237.4, 237.5, 355, 357; 250/225; 438/908, 16

(56) **References Cited**

U.S. PATENT DOCUMENTS

3,645,623 A * 2/1972 Patten 356/381

3,869,211 A	*	3/1975	Watanabe et al.	356/381
4,516,855 A	*	5/1985	Korth	
4,585,348 A	*	4/1986	Chastang et al.	
4,647,207 A	*	3/1987	Bjork et al.	
4,653,924 A	*	3/1987	Itonaga et al.	
4,681,450 A	*	7/1987	Azzam	
4,826,321 A	*	5/1989	Coates et al.	
4,842,410 A	*	6/1989	Darrah et al.	
4,957,368 A	*	9/1990	Smith	
4,962,063 A	*	10/1990	Maydan et al.	437/228
4,974,919 A	*	12/1990	Muraki et al.	359/204
4,999,014 A	*	3/1991	Gold et al.	
5,042,951 A	*	8/1991	Gold et al.	
5,061,072 A	*	10/1991	Folkard et al.	
5,120,966 A	*	6/1992	Kondo	
5,159,412 A	*	10/1992	Wilenborg et al.	
5,166,752 A	*	11/1992	Spanier et al.	
5,181,080 A	*	1/1993	Fanton et al.	
5,274,434 A	*	12/1993	Morioka et al.	356/237
5,420,680 A	*	5/1995	Isobe et al.	356/369
5,766,360 A	*	6/1998	Sato et al.	118/666

FOREIGN PATENT DOCUMENTS

EP 0558781 A1 * 9/1993
JP A 01054207 * 6/1989

* cited by examiner

Primary Examiner—Hoa Q. Pham

(74) *Attorney, Agent, or Firm*—Gary M. Nath; Todd L. Juneau; Joshua B. Goldberg

(57) **ABSTRACT**

A two dimensional beam deflector is disclosed which deflects beams from multiple optical assemblies. The input of beams of the multiple optical assemblies follow parallel optical paths until deflection to a wafer. An ellipsometer using a two-dimensional beam deflector is also disclosed.

22 Claims, 7 Drawing Sheets

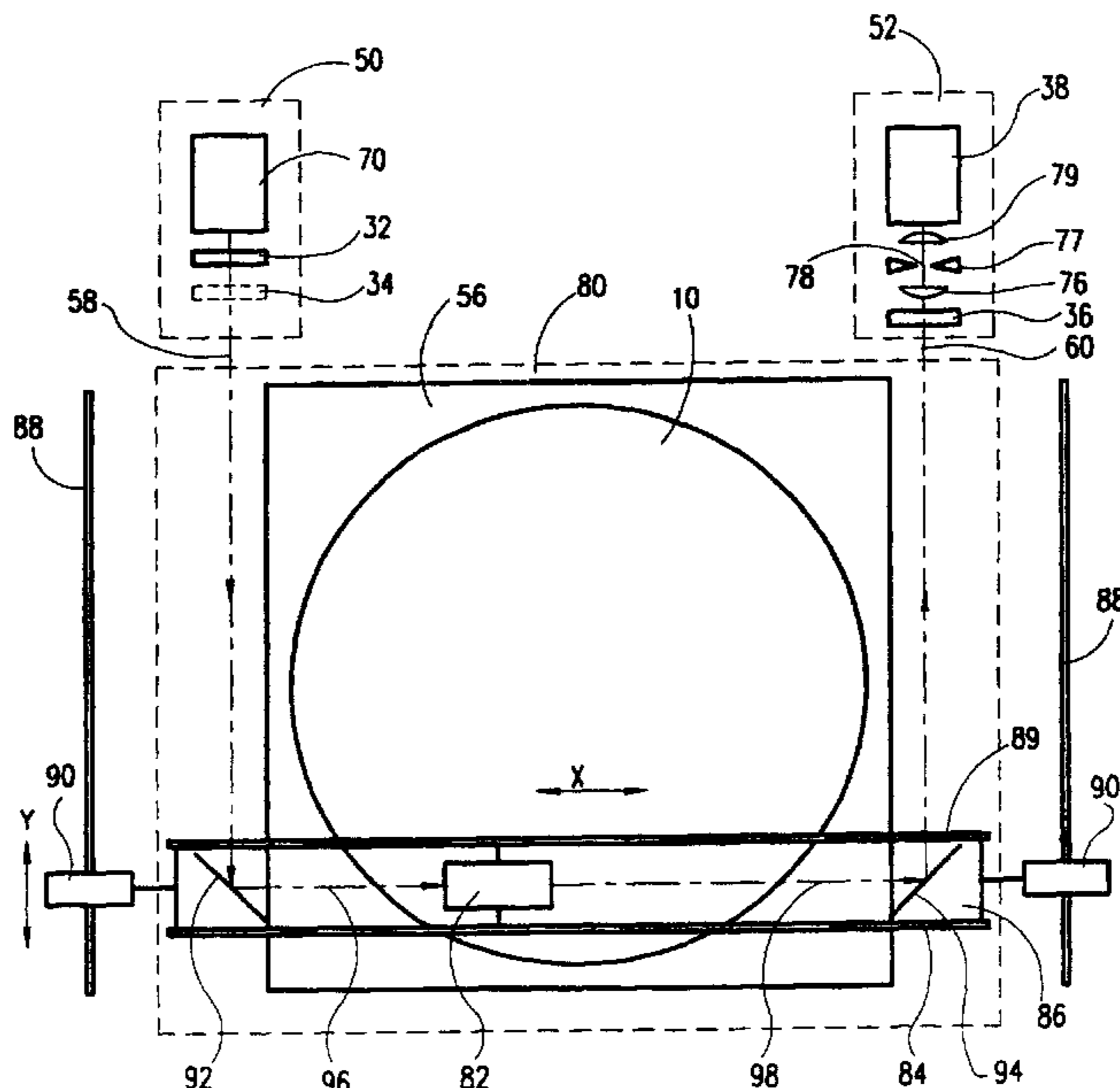

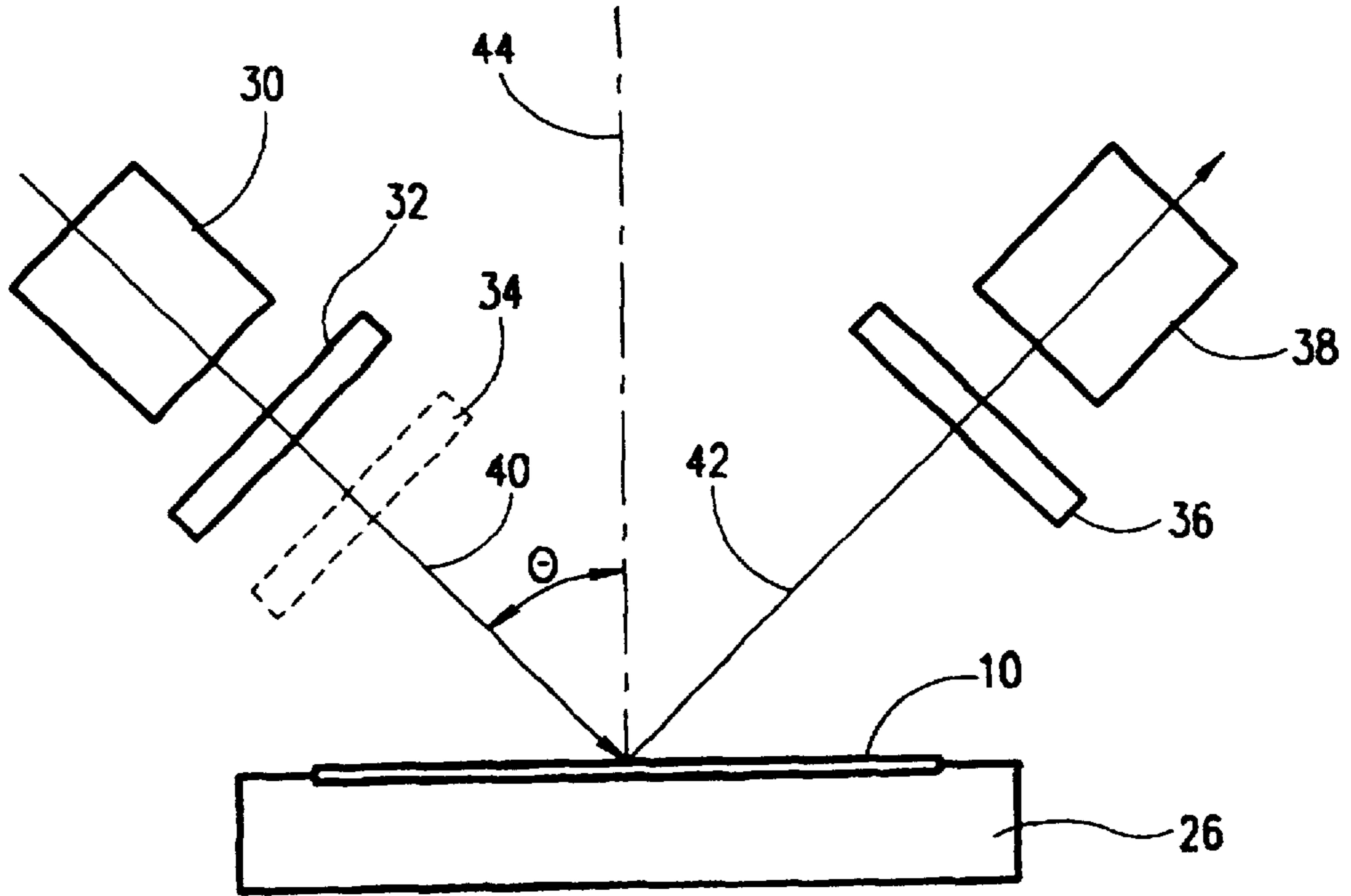

FIG. 1B
PRIOR ART

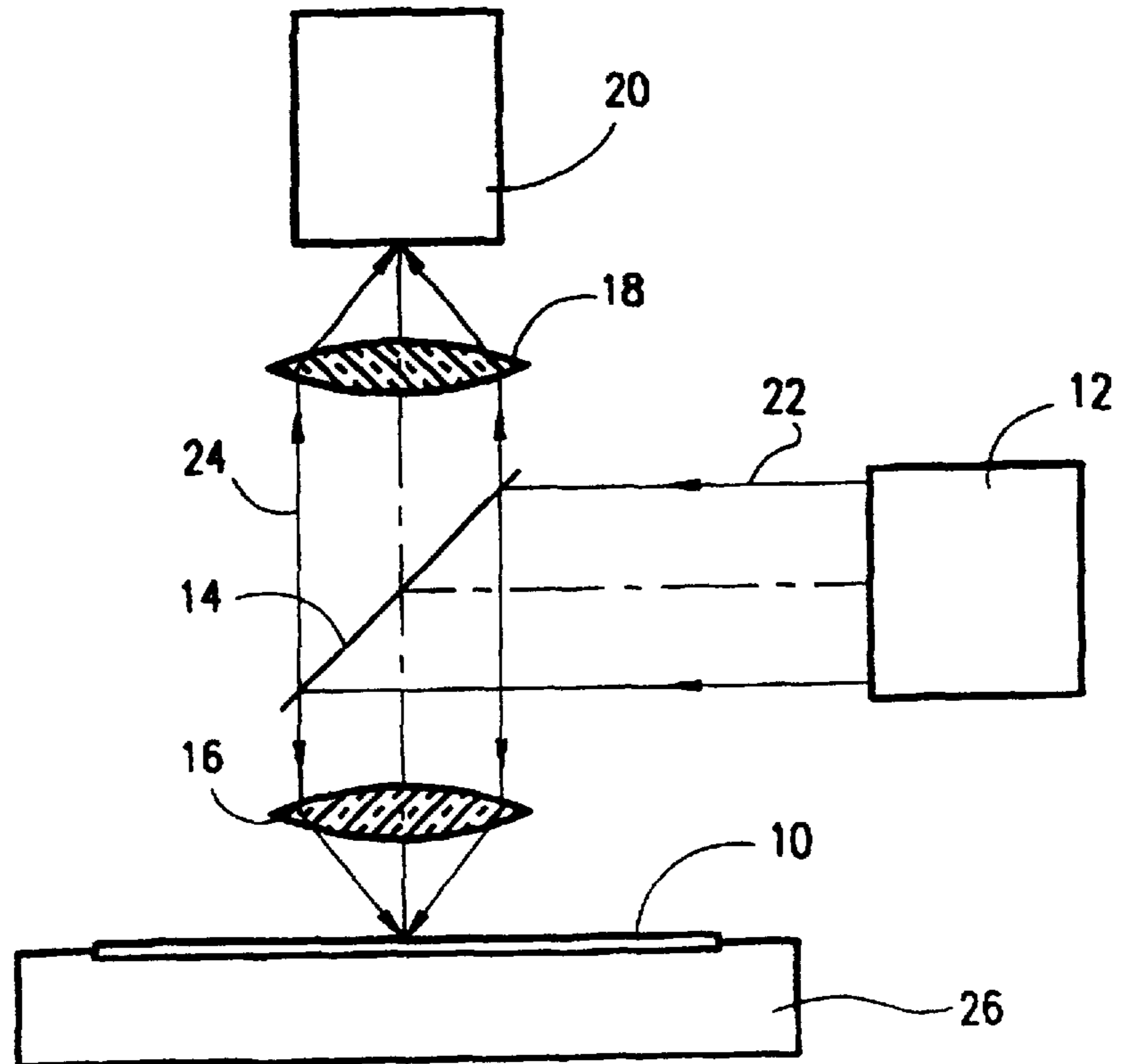
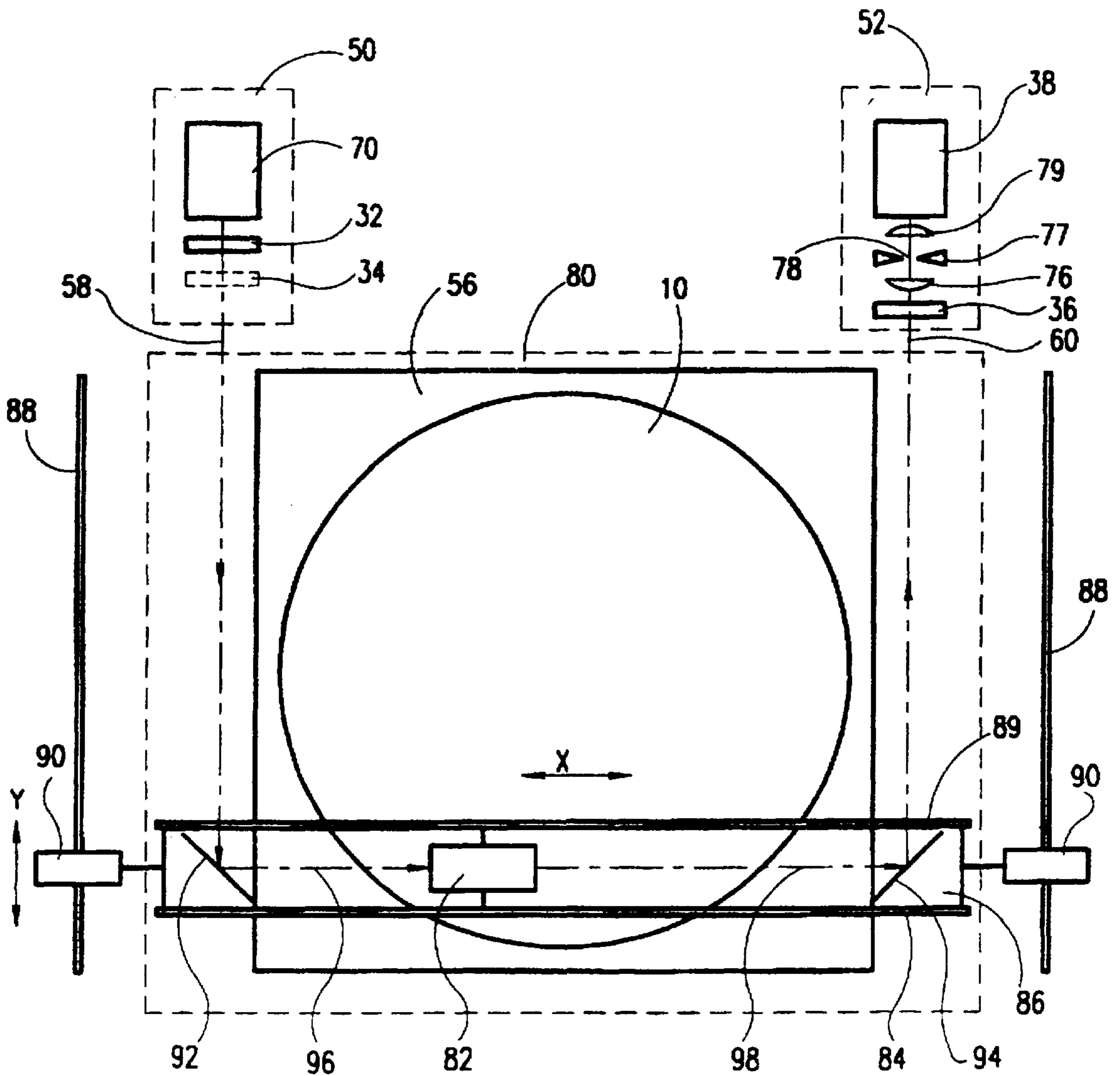
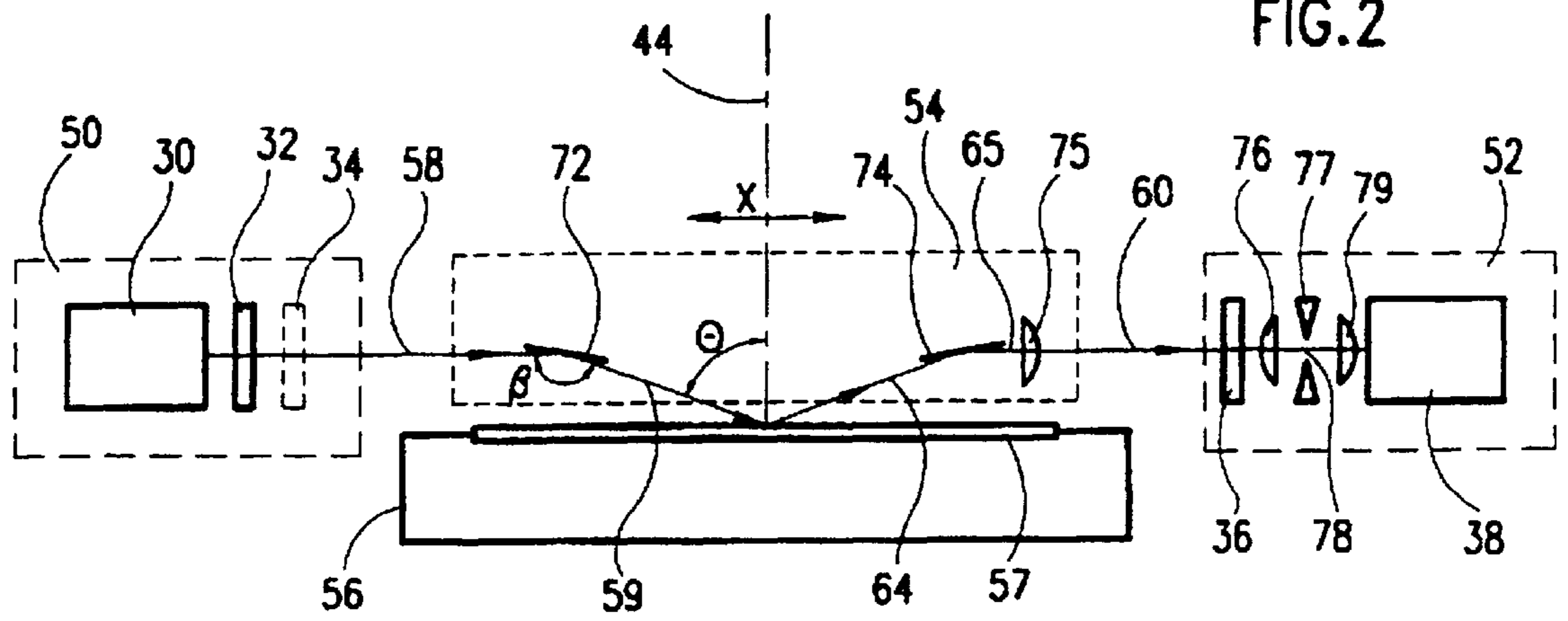
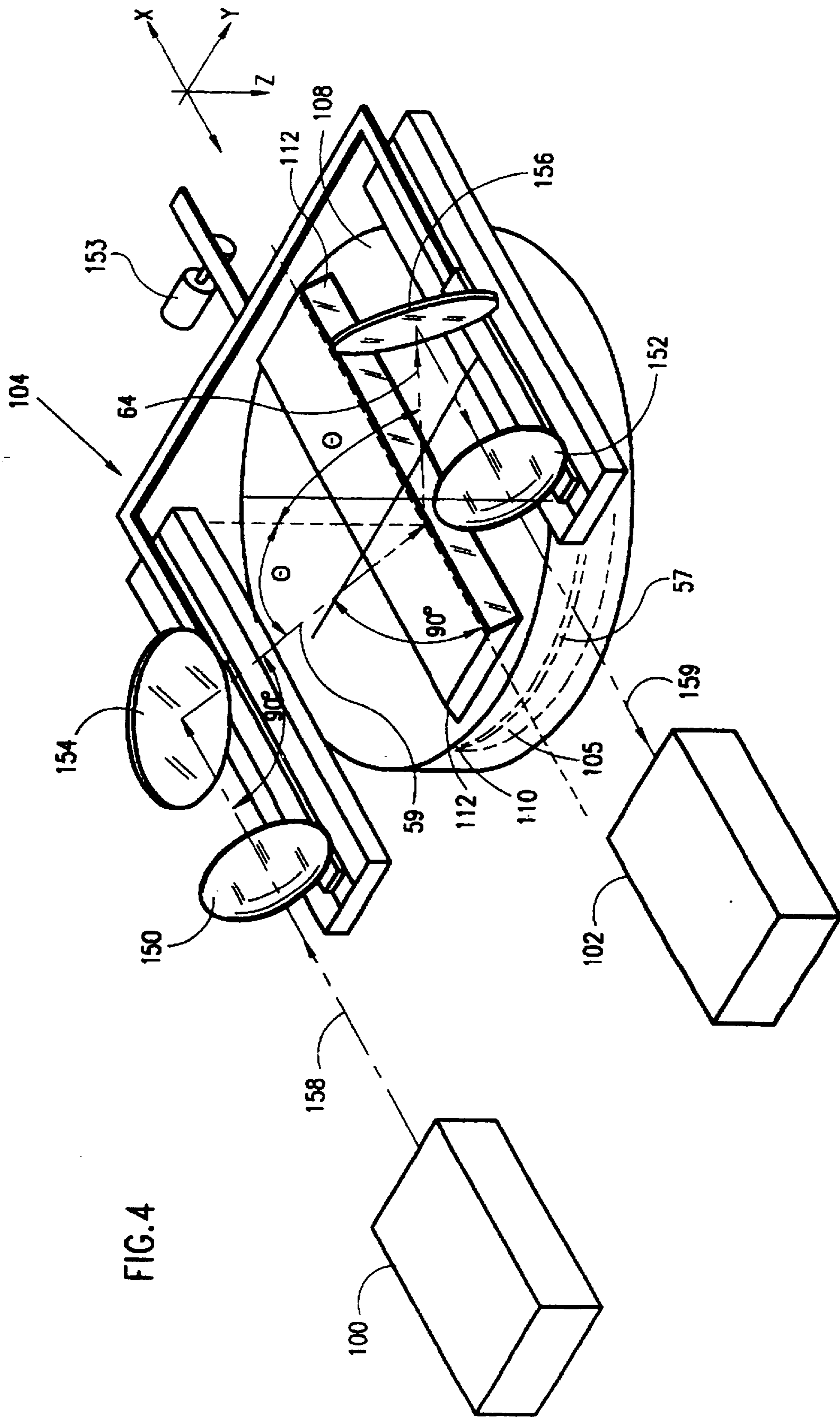

FIG. 1A
PRIOR ART





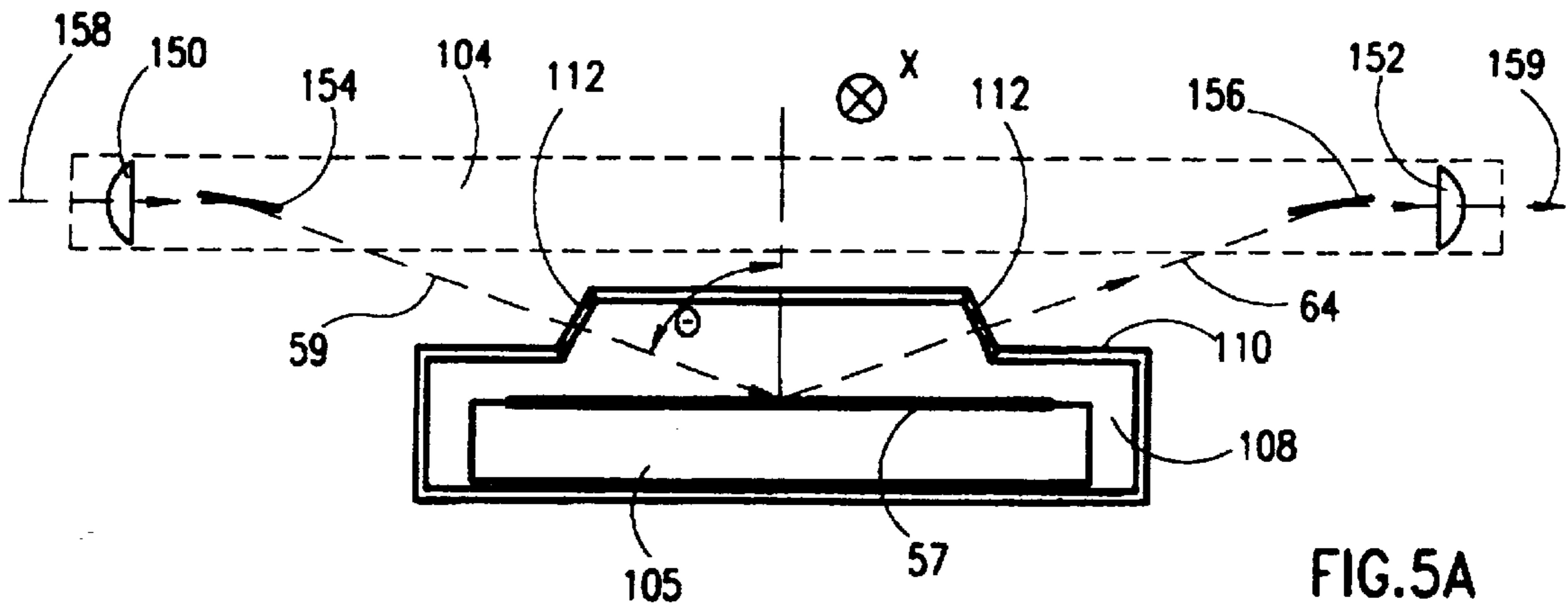

FIG. 5A

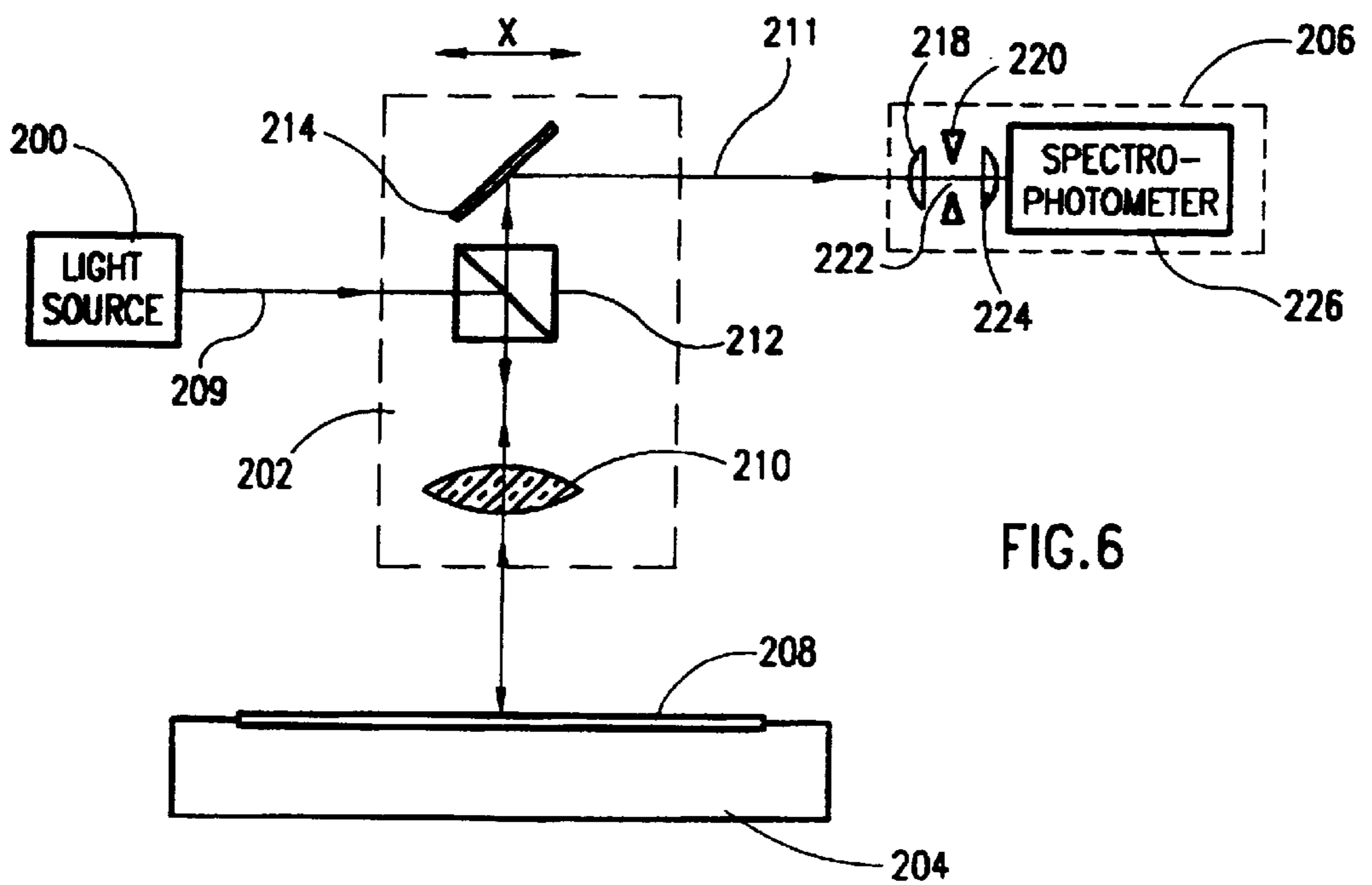

FIG. 6

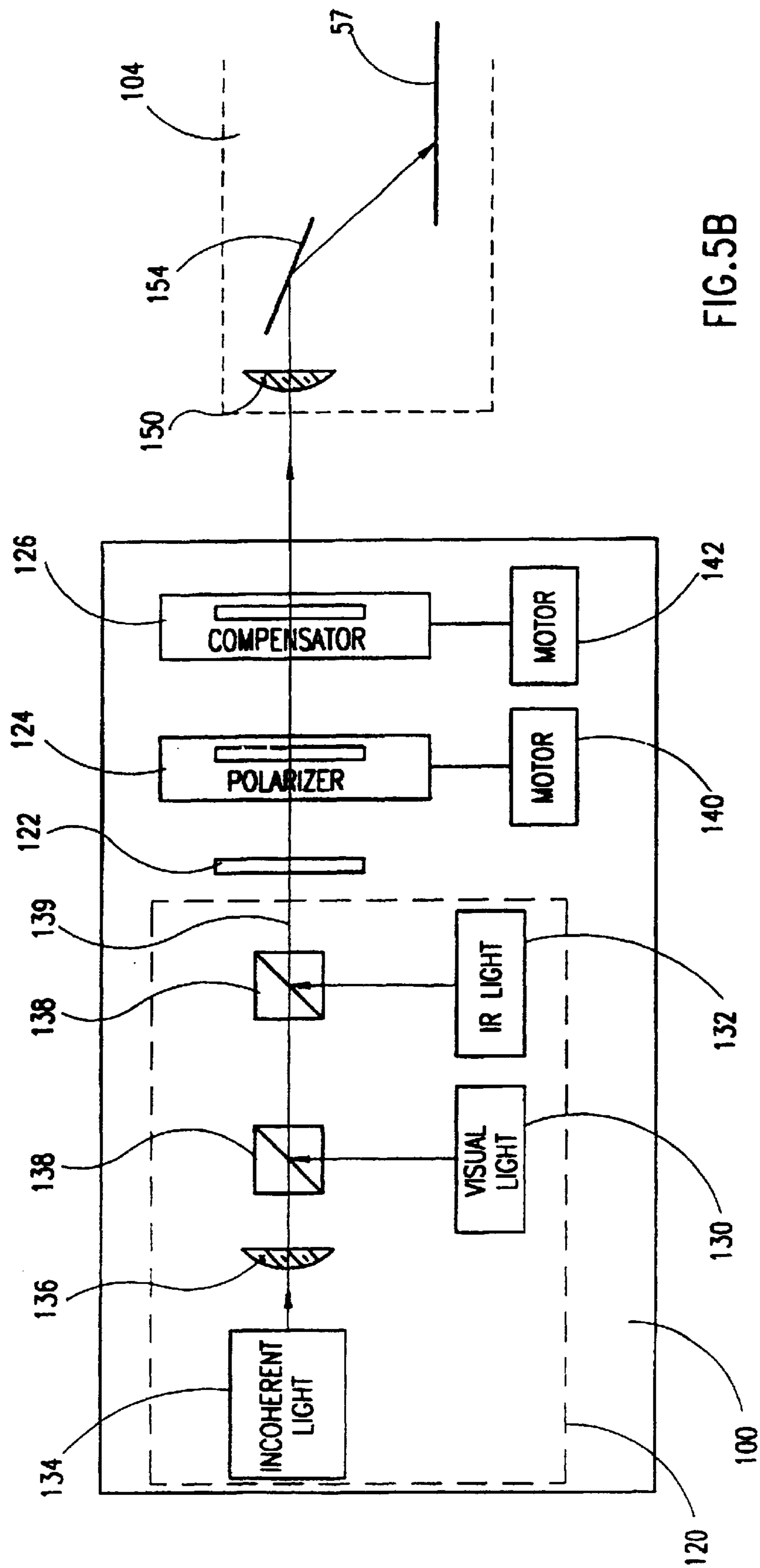

FIG. 5B

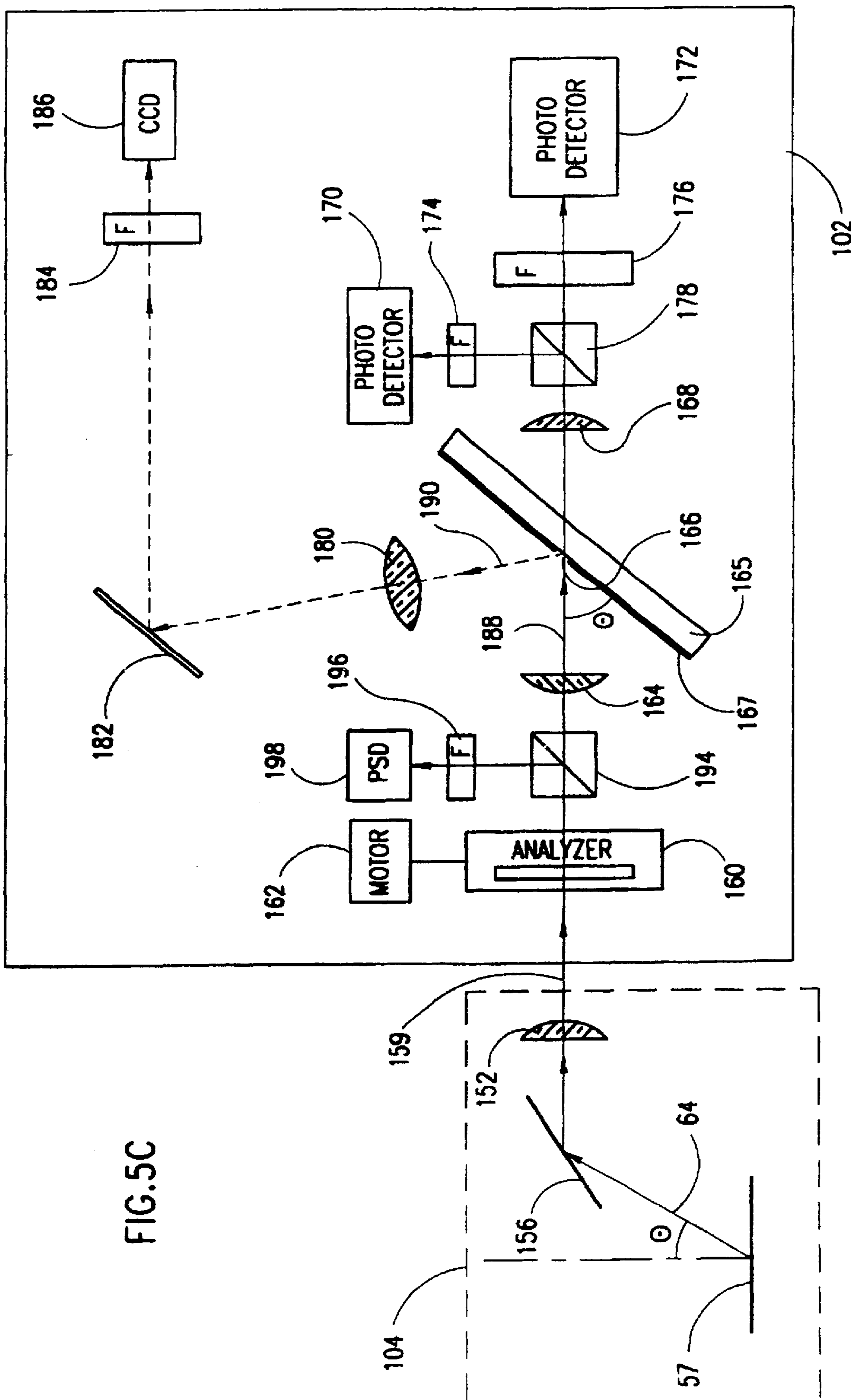

FIG. 5C

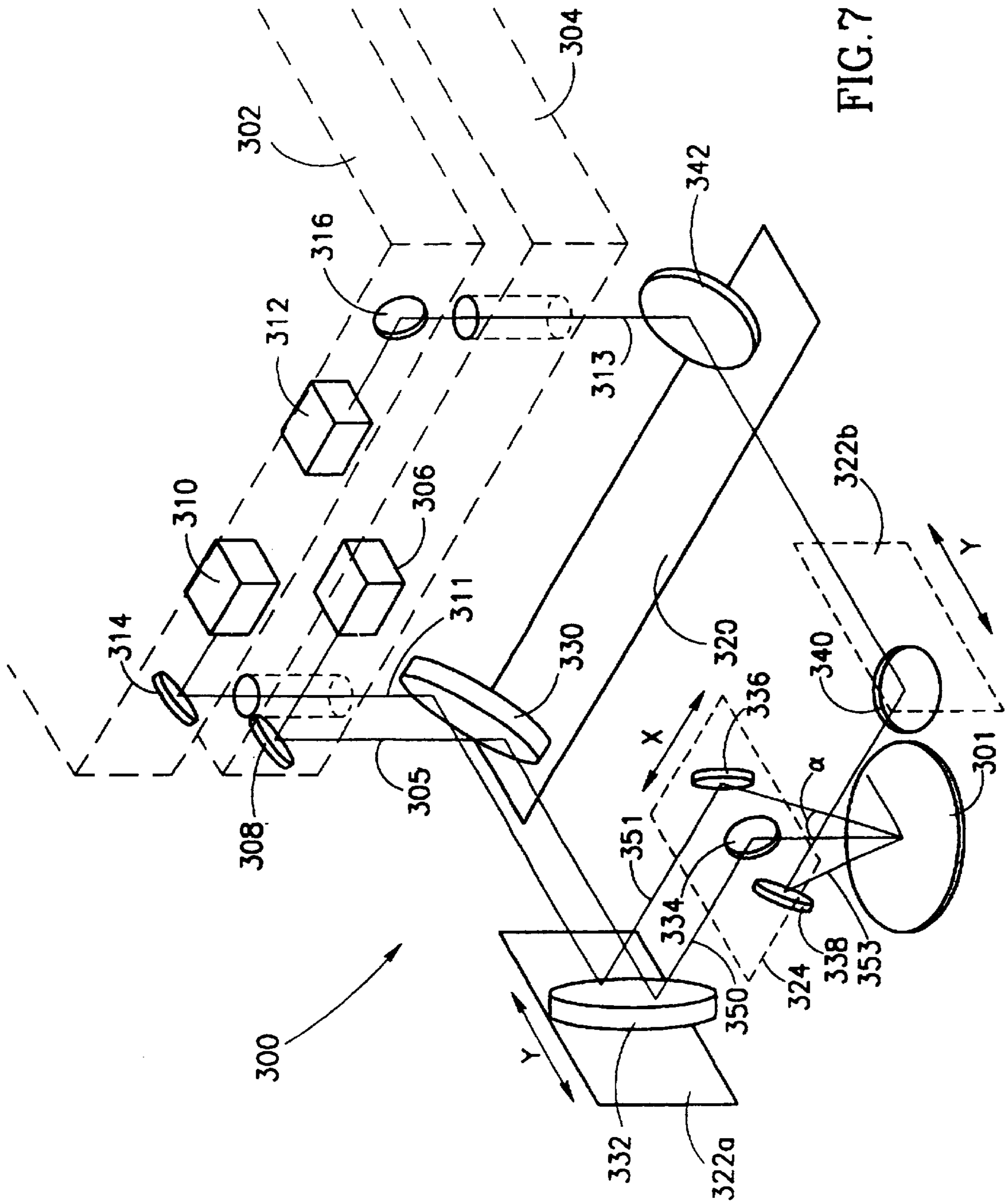

FIG. 7

TWO-DIMENSIONAL BEAM DEFLECTOR

Matter enclosed in heavy brackets [] appears in the original patent but forms no part of this reissue specification; matter printed in italics indicates the additions made by reissue.

CROSS REFERENCE TO RELATED APPLICATION

This application is a continuation-in-part of U.S. patent application Ser. No. 08/221,724, filed on Apr. 1, 1994, now U.S. Pat. No. 5,517,312.

FIELD OF THE INVENTION

The present invention relates to systems and methods for non-destructive quality control in general and to optical systems and methods for measuring the thickness and an index of refraction of thin films, in particular.

BACKGROUND OF THE INVENTION

Optical measuring instruments are typically utilized in the microelectronic industry for non-contact, non destructive measurement of the thickness of thin films. Two main systems are utilized, spectrophotometers (or reflectometers) and ellipsometers. The following U.S. patents represent the prior art:

For ellipsometers: U.S. Pat. Nos. 5,166,752, 5,061,072, 5,042,951, 4,957,368, 4,681,450, 4,653,924, 4,647,207 and 4,516,855.

For spectrophotometers: U.S. Pat. Nos. 5,181,080, 5,159,412, 5,125,966, 4,999,014 and 4,585,348.

The two prior art systems are illustrated in FIGS. 1A and 1B, respectively, to which reference is now made. The spectrophotometer utilizes the fact that light beams reflected off thin film boundaries, will interfere one with another. Specifically, the spectrophotometer of FIG. 1A measures the reflectance of selected points of a sample 10 as a function of the light wavelength, usually in the visible or near UV spectral ranges. Computer analysis of the detected spectral reflection function, especially its minima and maxima, provides the thickness, and in some cases, also the index of refraction of the measured film.

The spectrophotometer typically includes a transmitter 12 with a light source and appropriate optics, a beam splitter 14, an objective lens 16, a tube lens 18 and a receiver 20 which includes optical and electronic means for measurement of light intensity as a function of the input light wavelength. The transmitter 12 produces a collimated light beam 22 which is deflected by the beam splitter 14 and focused on the sample 10 by the objective lens 16. The reflected beam, labeled 24, is collected by the microscope imaging optics (lenses 16 and 18) on to a spectroscopic measurement unit within the receiver 20.

In order to measure a multiplicity of points on the sample 10, sample 10 is placed on an x-y stage 26. X-Y stage 26 is typically very precise and heavy and, as a result, moves very slowly.

The spectrophotometers have difficulty measuring structures with very small reflectance, such as thin films of glass substrates, because the relatively low brightness of traditional white light sources does not provide a sufficient signal-to-noise ration (SNR). Spectrophotometers also have difficulty measuring films with unknown or unrepeatable dispersions of optical constants, such as amorphous silicon.

Despite these limitations, the spectral photometry method is at present widely used in industry because the instrumen-

tation for this method is easily combined with optical microscopes and can utilize conventional microscope optics.

Ellipsometers measure changes in the polarization of light caused by reflectance from the test surface. These changes, characterized as amplitude and phase changes, are very sensitive to the thickness and optical properties of thin films.

A prior art ellipsometer is illustrated in FIG. 1B. It includes a transmitter 30 which includes a light source and appropriate optics, a polarizer 32, an optional compensator (phase retarder) 34, an analyzer 36 and a receiver 38 with a photo-detector and appropriate electronics. The polarizer 32 polarizes the light beam 40 produced by light source 30. The reflected light beam, labeled 42, passes through the analyzer 36 before reaching the receiver 38. If the compensator 34 is used, it may be located either between the polarizer 32 and the test sample 10 or between the sample 10 and the analyzer 36.

The ellipsometric method requires oblique illumination, i.e. an angle of incidence Θ between an incident light beam 40 and a normal 44 to the sample 10 must be greater than zero. The angle between a reflected light beam 42 and the normal 44 is equal to the angle of incidence Θ . The angle of incidence Θ should be close to the Brewster angle Θ_B of the substrate. In practice, the angle of incidence Θ ranges from 45° to 70° .

Because ellipsometers measure two polarization parameters (amplitude and phase), both of which are independent of the light intensity, they are quite accurate and can also measure ultra thin films of the size of 0-100 Å. However, since ellipsometers require oblique illumination as well as a highly collimated light beam, their use for high spatial resolution measurements in dense patterned structures is rather difficult.

There are two basic types of fully automated ellipsometers. Null-ellipsometers (NE) provide the most accurate thickness measurements but they require at least several seconds per measuring point. Rotating-analyzer ellipsometers (RAE) provide very high speed measurements (portions of a second per measuring point), but their sensitivity and accuracy are usually less than those of null ellipsometers.

For all of the prior art instruments, the opto-mechanical apparatus is complicated, large and heavy, and thus, the x-y stage 26 is translated between measurement points, coming to a complete stop before measurement begins. The time between measurements depends on the mass of the x-y stage 26 and on the positioning accuracy requirements and may take at least several seconds (sometimes up to several tens of seconds). This limits the speed with which a thickness mapping can occur, especially during inspection of large size substrates such as 8 Δ VLSI silicon wafers, 18"×18" LCD glass panels, etc.

The footprint, or space on the floor which each machine utilizes, is typically at least twice the size of the x-y stage 26 due to its translation.

Furthermore, the prior art measuring devices are utilized for measuring once a deposition process has been completed. They cannot be utilized for in-process control, since wafer handling and other mechanical movements are not allowed within a vacuum chamber.

Other measuring instruments are also known, one of which is described in U.S. Pat. No. 4,826,321. The '321 patent presents a system similar to an ellipsometer. However, in this system, a mirror is utilized to direct a plane polarized laser beam to the thin film surface at the exact Brewster angle of the substrate on which the thin film lies.

SUMMARY OF THE PRESENT INVENTION

There is provided, in accordance with a preferred embodiment of the present invention, a two-dimensional beam

deflector for a thickness measuring device for measuring the thickness of films on a sample with a plurality of different optical systems each performing a different measurement technique. The beam deflector includes a two dimensional translation unit, first and second deflection units and a plurality of optical assemblies. The two-dimensional translation unit translates the beam deflector along a first scanning axis and along a second scanning axis perpendicular to the first scanning axis. The first deflection unit receives a plurality of parallel input beams along parallel input axes which are close to one another and parallel to the first scanning axis. The first deflection unit also deflects the input beams along a plurality of parallel second axes close to each other and parallel to the second scanning axis. The second deflection unit receives a plurality of parallel output beams along parallel third axes close to each other and parallel to the second axes, and deflects the output beams along a plurality of parallel fourth axes close to each other and parallel to the first scanning axis. There is one optical assembly per input beam, each of which provides its input beam towards the sample, receives its output beam from the sample, processes its input and output beams in accordance with its measurement technique, and provides its output beams along the parallel third axes.

Additionally, in accordance with a preferred embodiment of the present invention, the optical assemblies can be at least an ellipsometric assembly and a spectrophotometric assembly.

There is also provided, in accordance with a preferred embodiment of the present invention, a thickness measuring device for measuring the thickness of thin films on a sample. The device includes first and second stationary illuminators, a beam deflector and first and second stationary receivers. The first and second stationary illuminators provide first and second collimated input light beams along first and second parallel input axes. The beam deflector directs the first and second input light beams towards the sample and direct and collimate corresponding first and second output light beams from the sample. The beam deflector includes a two-dimensional translation unit for translating the beam deflector along a first scanning axis parallel to the input axis, and along a second scanning axis perpendicular to the first scanning axis. The first and second stationary receivers respectively receive the first and second collimated output light beams along output axes parallel to the input axes.

There is further provided, in accordance with a preferred embodiment of the present invention, an ellipsometer which includes a stationary illuminator, a translatable beam deflector and a stationary receiver. The stationary illuminator provides a collimated input light beam along an input axis. The beam deflector, translatable at least along a first scanning axis parallel to the input axis, includes a) a first beam deflecting element for deflecting the input light beam at an angle of deflection towards the sample, b) a second beam deflecting element, different from the first beam deflecting element, for deflecting an output light beam reflected at an angle from the sample along the output axis and c) a collimating lens for receiving at least the output light beam from the second beam deflecting element and for collimating at least the output light beam. The stationary receiver receives the collimated output light beam along an output axis parallel to the input axis.

Additionally, in accordance with a preferred embodiment of the present invention, the beam deflector comprises one-dimensional translation unit for translation along the scanning axis. Alternatively, the beam deflector comprises two-dimensional translation unit for translating the beam

deflector along the first scanning axis and along a second scanning axis perpendicular to the first scanning axis.

Moreover, in accordance with a preferred embodiment of the present invention, the beam deflector additionally comprises a first mirror for deflecting the input light beam from the input axis to the second scanning axis, a second mirror for deflecting the input light beam from the second scanning axis to the sample, a third mirror deflecting a reflected light beam from the sample to the second scanning axis, and a fourth mirror for deflecting the reflected light beam from the second scanning axis to the output axis.

Furthermore, in accordance with a preferred embodiment of the present invention, the first and second beam deflecting elements are mirrors.

Additionally, in accordance with a preferred embodiment of the present invention, the first beam deflecting element is a beam splitter and the second beam deflecting element is a mirror.

Finally, in accordance with a preferred embodiment of the present invention, the ellipsometer includes a unit for measuring an actual angle of incidence which may vary from the angle of deflection, wherein the unit for measuring utilizes optical elements forming part of the stationary illuminator and stationary receiver. The unit for measuring includes a position sensing device for measuring the angle of the output light beam with respect to a desired position.

BRIEF DESCRIPTION OF THE DRAWINGS

The present invention will be understood and appreciated more fully from the following detailed description taken in conjunction with the drawings in which:

FIGS. 1A and 1B are schematic illustrations of a prior art spectrophotometer and a prior art ellipsometer;

FIG. 2 is a schematic side view illustration of an optical measuring device having a one-dimensional scanning device incorporated therein, constructed and operative in accordance with a preferred embodiment of the present invention;

FIG. 3 is a schematic top view illustration of an optical measuring device having a two-dimensional scanning device incorporated therein, constructed and operative in accordance with a second preferred embodiment of the present invention;

FIG. 4 is a partial schematic, partial block-diagram illustration of an ellipsometric in-process thickness monitor utilizing the principles illustrated in FIG. 2;

FIG. 5A is a side view schematic illustration of a beam deflector cooperating with a vacuum chamber, the beam deflector forming part of the monitor of FIG. 4;

FIG. 5B is a schematic illustration of an illumination unit and part of the beam deflector of FIG. 5A, both forming part of the monitor of FIG. 4;

FIG. 5C is a schematic illustration of a detection unit and part of the beam deflector of FIG. 5A, both forming part of the monitor of FIG. 4;

FIG. 6 is a schematic illustration of a spectrophotometer having a one-dimensional scanning device incorporated therein, constructed and operative in accordance with the principles of the present invention; and

FIG. 7 is a schematic illustration of a further embodiment of the beam deflector of the present invention which deflects beams from two different optical assemblies.

DETAILED DESCRIPTION OF PREFERRED EMBODIMENTS

Reference is now made to FIGS. 2 and 3 which schematically illustrate an optical measuring device having one

and two-dimensional scanning devices, respectively, constructed and operative in accordance with preferred embodiments of the present invention. In FIG. 2 is a side view and FIG. 3 is a top view.

In FIGS. 2 and 3, the optical measuring device is an ellipsometer. This is by way of example only; the principles of the present invention can also be implemented in a spectrophotometer, as illustrated in FIG. 6, described in detail hereinbelow.

The ellipsometer of FIG. 2 typically comprises a stationary illuminator 50, a stationary detector 52, a translating beam deflector 54, and a stationary support 56, such as a stage, ring, etc., for holding a sample 57.

The illuminator 50 typically comprises of elements similar to those of the prior art. Therefore, similar elements have similar reference numerals.

Specifically, the illuminator 50 typically comprises transmitter 30 which includes a laser light source, a polarizer 32 and an optional compensator (phase retarder) 34. As in the prior art, the laser light source, with its associated optics (not shown), produces a highly collimated laser light beam.

The beam deflector 54 typically comprises two mirrors 72 and 74 and a first objective lens 75. Mirror 72 provides the desired angle of incidence Θ to input light beam 58 by deflecting beam 58 by an angle $\beta=90+\Theta$. Mirror 74 deflects a light beam 64, reflected from the sample 57, to a beam 65 along a direction parallel to the X scanning axis. First objective lens 75, whose focal plane is at the plane of sample 57, typically collimates beam 65, thereby producing a collimated reflected beam 60.

To effect scanning, only the beam deflector 54 is translated along the X-axis. The movement of the beam deflector 54 generally does not affect the measurement quality of the ellipsometer since the input and output light beams 58 and 60 are highly collimated and parallel to the scanning axis.

Because beam deflector 54 only comprises the mirrors 72 and 74 and objective lens 75, it is lightweight and therefore, its translation is fast, on the order of the measurement time. The support 56 is stationary, therefore, the device of the present invention has a minimal footprint of the size of the sample 57.

It is noted that the direction changing effected by mirrors 72 and 74 changes the polarization state of the light. These undesired changes must be separated from the desired polarization changes caused by the sample 57. If the optical parameters of the mirrors are stable, the undesired changes do not vary and thus, they can be measured and accounted for when interpreting the measurement of the sample 57.

It is further noted that reflection from the mirrors 72 and 74 may not be fully specular. Typically, some depolarized scattered light is also produced. While the percentage of scattered light is very small relative to the specular light (1:1000 or even less, depending on the quality of the mirror surface), the scattered light could limit the signal-to-noise ratio (SNR) of the system and thus, limit the measurement accuracy.

In accordance with a preferred embodiment of the present invention, the detector 52 typically comprises scattered light reducing elements in addition to the standard analyzer 36 and receiver 38. The scattered light reducing elements typically are a second objective lens 76 and a diaphragm 77, located at the focal plane of objective lens 76 and having a pinhole 78, and a condenser 79.

The analyzer 36 is typically placed within the collimated light beam 60, between objective lenses 75 and 76. Since

pinhole 78 is placed at the center of the image plane which is the focal plane of lens 76, it acts as an aperture stop, allowing only the collimated portion of light beam 60 to pass through. Thus, the pinhole drastically reduces the widely scattered depolarized light introduced by the mirrors. Condenser 79 collects the light from the pinhole 78 and provides it to receiver 38.

For a pinhole 76 of 50 μm in diameter and a lens with a focal length of 30 mm, the angular aperture of the detector 52 is less than one mrad. For optical configurations having six or fewer mirrors between the polarizer 32 and the analyzer 36, the resultant intensity of scattered light reaching the detector 38 is less than $10^{-3}\%$ of the polarized light which is the minimum necessary for accurate ellipsometric measurements.

Receiver 38 typically comprises a photo-detector and appropriate electronics. Although not shown, the detector 52 can also include the compensator 34, located before the analyzer 36.

The ellipsometer of FIG. 3 provides two-dimensional scanning with a two-dimensional scanning unit 80. The remaining elements are similar to those of FIG. 2 and therefore, have similar reference numerals.

Scanning unit 80 typically comprises a beam deflector 82 (see FIG. 2) similar to beam deflector 54, which slides along X-axis rails 84. The X-axis rails 84 are attached together and to carriages 90, forming an X-axis unit 86 which, in turn, translates along Y-axis rails 88 via the carriages 90.

Scanning unit 80 typically also comprises mirrors 92 and 94 (see FIG. 3) which deflect beams between the X- and Y-axes. Specifically, mirror 92 deflects the input beam 58 from the Y axis to the X axis, producing beam 96 which is parallel to the X axis. Mirror 94 receives beam 98, the output of the beam deflector 82, along the X axis and deflects it towards the Y-axis, producing thereby reflected beam 60.

It is noted that the scattered light reducing elements 76-79 are efficient for a number of mirrors, as long as none of the mirrors are located very close to either the object or image planes.

Reference is now made to FIGS. 4 and 5A, 5B and 5C which illustrate an in process thickness monitor. FIG. 4 is a partial schematic, partial block-diagram illustration and FIGS. 5A-5C are schematic illustrations of the elements of the monitor of FIG. 4.

The monitor of FIG. 4 is operative to measure the thickness of the thin films within deposition equipment such as cluster tools. A cluster tool is a large vacuum system which consists of several chambers, each performing a specific deposition process on a single silicon wafer ("single wafer processing"). An internal robot transfers each wafer from chamber to chamber without breaking the vacuum, thus several deposition processes may be carried out before the wafer is removed from the cluster tool.

The present invention is typically installed on a cool-down vacuum chamber to which each wafer is brought for one-two minutes after each deposition process. It thus measures the film thickness after each deposition.

In accordance with the present invention, the in-process monitor comprises a coherent and an incoherent imaging unit and an angle of incidence measuring unit, portions of whose optical paths are identical. The coherent imaging unit is utilized for ellipsometric measurements and thus, is similar to that described hereinabove with respect to FIG. 2. The incoherent imaging unit is typically operative for pattern recognition.

The monitor comprises an illumination unit, labeled **100**, a detection unit, labeled **102**, a beam deflector, labeled **104**, and support **105**, similar to support **56**.

Since a vacuum must be maintained, all of the elements of the monitor, except the support **105** and the sample **57** on it, must exist outside of the vacuum chamber, labeled **108**. This is shown in FIGS. **4** and **5A**.

In accordance with the present invention, built into a cover **110** of vacuum chamber **108**, along the direction of the X-axis, are two stationary glass plates **112** operative to enable the light beam to reach the sample **57** from outside the chamber. To minimize the influence plates **112** have on optical measurements, the planes of their surfaces are located perpendicular to the path of optical beams **59** and **64**.

The glass plates **112** are mechanically strong enough to withstand the pressure difference between the vacuum within chamber **108** and the atmospheric pressure outside of it. The plates **112** are made from stress free glass of about 5 mm thick and their aspect ratio (width/length) is about 1:50. The resultant induced birefringence is negligible and therefore, the plates generally do not affect the optical measurements.

Beam deflector **104** (see FIG. **5A**) typically comprises focusing lens **150** and objective lens **152**, two mirrors **154** and **156** and X-axis translation apparatus **153** (see FIG. **4**), such as a linear motor.

During ellipsometric measurements, focusing lens **150** focuses the polarized and collimated light beam, labeled **158**, onto the surface of sample **57** and the objective lens **152** collimates the divergent beam **64** into the reflected beam, labeled **159**. An important fact to note is that lenses **150** and **152** are thin, simple lenses made of stress free glass to reduce to zero their birefringence. They may also be located between the mirrors **154** and **156** and the sample **57**.

The two mirrors **154** and **156** are similar to mirrors **72** and **74** of FIG. **2** and are operative to direct the light beam to and from the sample **57** at the desired angle of incidence Θ in the Y-Z plane and to deflect the light beam between the X- and Y-axes, as shown in FIG. **4**.

Thus, the light beam **59** always impinges on the sample **57** at the desired angle of incidence Θ , even though the beam deflector **104** is translated along the X-axis.

The illumination unit **100** is detailed in FIG. **5B** and typically comprises a light source unit **120**, a quarter wave plate (QWP) **122**, a polarizer **124** and a compensator **126**.

The light source unit **120** typically comprises two coherent light sources **130** and **132** for ellipsometric measurements and one incoherent light source **134** and a condenser **136** for incoherent imaging. The condenser **136** collimates the output of light source **134**.

Illumination unit **100** also comprises two beam splitters **138** for combining the light from the three light sources **130**, **132** and **134** onto a single path **139**. Beam-splitters **138** typically are dichroic or polarizing. If they are polarizing, the planes of polarization of the two lasers **130** and **132** are set to be orthogonal.

The two coherent light sources **130** and **132** are laser diodes which produce highly monochromatic and collimated light for ellipsometric measurements. Laser **130** has a wavelength λ_1 in the visible spectral range, preferably within the range of 630 to 680 nm, and laser **132** has a wavelength λ_2 in the near infra-red (IR) spectral range, preferably within the range of 810 to 830 nm. The visible light is preferable for measuring such films as silicon dioxide, silicon nitride and other dielectric layers. The IR

light is preferable for silicon layers (poly-silicon, amorphous silicon and the like). Under IR light, the silicon layers are almost transparent and their optical parameters are generally repeatable between processes.

The incoherent light source **134**, used during pattern recognition, can be any suitable light source, such as a high brightness LED, quartz-tungsten lamp, xenon arc lamp, etc. Its specific range should preferably be narrow, for example 780 ± 20 nm.

During imaging operations, the incoherent light source **134** is operative and it, together with the focusing lens **150**, and the condenser **136** form an incoherent illuminator whose light beam forms an incoherent light spot on the surface of sample **57**. The size and divergence of the incoherent light beam must be sufficient to illuminate the desired field of view, e.g. about 1 mm in its shortest dimension, at any position of the beam deflector **104** along the X-axis.

The quarter-wave plate (QWP) **122**, useful for ellipsometric measurements, is oriented with its optical axis at an angle of $\pm 45^\circ$ relative to the planes of polarization of the lasers **130** and **132** and transforms their linear polarization to a circular one. The QWP **122** should be achromatic throughout the utilized spectral range of 630 to 830 nm. Suitable achromatic QWPs are manufactured, for example, by Meadowlark Optics company, U.S.A.

The polarizer **124** and compensator **126** have associated therewith motor drives **140** and **142**, respectively. Although not shown, motor drives **140** and **142** typically operate with precise angular encoders. Since most ellipsometric measurement algorithms do not require rotation of the compensator, a manual driving mechanism (for alignment only) may alternatively be used instead of the motor drive **142**.

For the two wavelength configuration of the present invention, the polarizer **124** is achromatic. A suitable polarizer is a Glan-Thomson polarization prism. For a single wavelength configuration in the red spectral range, a sheet polarizer, such as the HN38S type from Polaroid Corporation of the U.S.A., is suitable. For all polarizers, an extinction ratio of more than 10^5 is required for reaching the thickness measurement accuracy required in microelectronic deposition process control.

The detection unit **102** (FIG. **5C**) typically comprises a two-dimensional image acquisition system (part of the incoherent imaging unit), an ellipsometric detector unit (part of the coherent imaging unit) and an angle of incidence measurement unit.

The ellipsometric detector unit of detection unit **102** is comprised of elements similar to those of the ellipsometer of FIG. **2**, but extended to operate with the two wavelengths, λ_1 and λ_2 . The ellipsometric detector unit operates with the objective lens **152** and typically comprises the analyzer, labeled **160**, its associated motor **162**, an imaging lens **164**, a diaphragm **165** having a pinhole **166**, a condenser **168**, two independent photo-detectors **170** and **172**, two band pass spectral filters **174** and **176** and a beam splitter **178**. The analyzer **160** is similar to polarizer **124** and is therefore, achromatic for the two wavelength configuration.

Since, as in the embodiment of FIG. **2**, the pinhole **166** is located at the image plane of the optical imaging system (lenses **152** and **164**) which is the focal plane of lens **164**, only that portion of the light reflected from the surface of sample **57** which is the size of pinhole **166** will come through pinhole **166**. Condenser **168** collects the light and focusses it onto the photo-detectors **170** and **172**.

The beam splitter **178** splits the incoming beam into two beams, each having the appropriate wavelength, λ_1 and λ_2 .

The photo-detectors **170** and **172** detect, via the filters **174** and **176** respectively, the intensity of light of the two wavelengths λ_1 and λ_2 , respectively. For most applications, the photo-detectors are silicon photovoltaic detectors, such as the S5591 manufactured by Hamamatsu Photonics U.U. of Hamamatsu City, Japan. If necessary, more sensitive but more expansive photo-multipliers may be used.

It is noted that the present invention allows simultaneous measurement of two wavelengths which enables the measurement of two pairs of ellipsometric parameters, the amplitude parameter ψ and the phase parameter Δ . As a result, four parameters of the thin film structure, e.g. thickness and index of refraction of each of two layers, can be simultaneously determined. Such a measurement is useful when two different layers are deposited on the sample **57** in one deposition cycle.

Since lenses **152** and **164** are designed to be generally free of aberrations in the two wavelengths λ_1 and λ_2 , the spatial resolution of the monitor of the present invention depends only on the size of pinhole **166** and on the point spread function of the coherent imaging system. The point spread function is defined by the F-stop of the coherent imaging system and is generally quite small. Practically, the thickness measurements are carried out on scribe lines, pads or special test areas which are not less than $50 \mu\text{m}$ wide and therefore, a pinhole size of $20\text{--}40 \mu\text{m}$ and an F# of $5\text{--}6$ is acceptable.

It is noted that a circular pinhole produces an elliptical measurement spot, with an aspect ratio of $1/\cos\Theta$. If this is unacceptable, the shape of pinhole **166** has to be asymmetrical to compensate.

The two-dimensional image acquisition system typically operates in conjunction with the incoherent image illuminator and utilizes the objective lens **152** located on the beam deflector **104**. The image acquisition system typically comprises the imaging lens **164**, the diaphragm **165** with the pinhole **166**, a magnifying lens **180**, a mirror **182**, an optional band pass filter **184** and a high resolution, area charge coupled device (CCD) **186**. For the purpose of the image acquisition system, the diaphragm **165** is made from a grating **167** which has the pinhole **166** therein. The grating **167** does not affect the ellipsometric measurements.

The surfaces of sample **57** and grating **167** are respectively located in the focal planes of lenses **152** and **164**. The lenses **152** and **164** typically have the same focal length, thereby providing an optical magnification M of $1\times$.

As is known in the art, if the object plane is tilted relative to the imaging axis (the axis of the reflected beam **64**), the image plane is also tilted relative to the optical axis (the axis of a beam **188**) from the analyzer **160**. However, the extent of the tilting of the image plane is a function of the magnification, as described by the Scheimpflug equation:

$$\text{tg}\Theta' = M - \text{tg}\Theta, \quad (1)$$

where Θ is the angle of incidence and Θ' is the tilt angle of the image plane.

In the monitor of FIG. 5, the grating **167**, tilted by the angle Θ relative to axis **188**, is the imaging plane for the imaging system of lenses **152** and **164** and is the object plane (or intermediate image plane) for the imaging system of lens **180**.

Since the magnification M of the monitor is 1, the object plane (sample surface) and the image plane are tilted at the same angle Θ relative to their optical axes. Unfortunately, when the image plane is thus tilted, only a portion of it can be focussed on the CCD **186**.

In order to force the image plane to be perpendicular to the optical axis, thereby ensuring that the entire image plane is focused on the CCD **186**, the grating **167** is aligned along the intermediate image plane. The grating **167** is chosen so that only the first diffraction maximum is utilized for imaging to the CCD **186**. For example, for $\lambda_3 = 780\text{nm}$, $\Theta = 70^\circ$ and a grating frequency 1200 cycles/mm , the image plane of a diffracted beam **190** is almost perpendicular to the optical axis. Therefore the image plane may be enlarged by the magnifying lens **180** without the above-described Scheimpflug problem.

The magnifying lens **180** is placed in the direction of the first diffraction maximum for the wavelength λ_3 of the incoherent illuminator. The lens **180** provides magnification, of at least $5\times$, which is strong enough for recognition of the test areas on the wafer.

Mirror **182** directs the diffracted beam **190** towards the CCD **186** which is located at the image plane of magnifying lens **180**. The high resolution CCD **186**, such as the TM-6CN CCD manufactured by Pulnix America Inc. of Sunnyvale, Calif., U.S.A., transforms the image to a video signal.

If lasers **130** and **132** operate at the same time as the incoherent light source **134**, the optional band pass filter **184** ensures that only light from the incoherent illuminator is used for imaging.

If the incoherent light is not monochromatic, the diffraction of grating **167** will produce spectral dispersion. In this case, the numerical aperture of lens **180** has to be high enough to collect most, if not all, of the diffraction beams within the entire spectral range. In order to achieve high image quality, the lens **180** should be corrected for the chromatic aberrations in the spectral range of the incoherent light.

The quality of the obtained image depends strongly on the F-stops (F#) of the objective and imaging lenses **152** and **164** and the aberrations that they produce. For a focal length for lenses **152** and **164** of about 30 mm and a beam diameter of about 5 mm , the F# is about 6 , a value which is used for high quality photography and other applications.

The lens **180** is a high quality microscope grade objective lens and therefore, does not significantly affect the final image quality. The grating **167** also does not significantly affect the image quality because its spatial frequency in the image plane ($1200/5\times = 240 \text{ cyc/mm}$) is significantly greater than the Nyquist frequency of the CCD (about 50 cyc/mm). Therefore the above two-dimensional image acquisition system provides the high spatial resolution needed for accurate pattern recognition.

For the two-dimensional image acquisition system, the pinhole **166** serves to locate the measurement spot in the image of the sample **57**. Since the pinhole **166** is located at the intermediate image plane (grating **167**) and since it allows light to pass through it, rather than being reflected toward the CCD **186**, the pinhole **166** appears as a sharp dark point in the image produced by the CCD **186**. Thus, when viewing the CCD image, the location of the measurement spot is immediately known, it being the location of the dark spot.

It is noted that the pinhole **166** performs three functions: 1) it reduces the scattered light from the mirrors **154** and **156**; 2) it provides high spatial resolution; and 3) it provides an indication of the location of the measurement spot in the image of the area being measured.

The angle of incidence measurement unit provides feedback about the actual angle of incidence Θ for situations when the surface of the sample **57** is not absolutely flat.

The angle of incidence measurement unit typically comprises the objective lens **152**, a beam-splitter **194**, a spectral filter **196** and a position-sensitive detector (PSD) **198**, such as the S2044 detector manufactured by Hamamatsu Photonics U.U. Beam splitter **194** provides a portion of reflected beam **159** to the PSD **198** via the spectral filter **196**.

Since the measurement point on the sample **57** is in the focal plane of objective lens **152** and since the PSD **198** is in the far field of this lens, any change in the angle of reflection (equal to the angle of incidence on the non-flat surface of sample **57**) displaces the light spot on the PSD **198** and may be accurately measured. If the light spot is centered on the PSD **198**, the angle of incidence is expected angle of incidence Θ , typically of 70° . If the spot is below or above the central location, the actual angle of incidence is larger or smaller, respectively, than Θ . The relationship describing the extend of the skew with the change in the actual angle of incidence is calibrated prior to operating the monitor. The ellipsometric measurements are then interpreted, by a data processor (not shown), in light of the actual angle of incidence.

It is noted that most supports typically comprise means (not shown) for keeping the top surface of sample **57** in a fixed position, such as by vacuum or electrostatic clamping, an auto-focus mechanism. Once such systems have been actuated, the only reason for beam displacement on the PSD **198** is the deviation in the angle of incidence.

Reference is now made to FIG. **6** which illustrates a spectrophotometer designed in accordance with the principles of the present invention. Thus, the spectrophotometer comprises a light source **200**, a beam deflector **202**, a support **204** holding a sample **208**, a detector unit **206**.

The beam deflector **202** typically comprises an objective lens **210**, a beam splitter **212** and a mirror **214**. From the light source **200**, the beam splitter receives a light beam **209**, parallel to the surface of the sample **208**, and deflects it toward the sample **208**, via lens **210**. The sample **208** is located in the focal plane of lens **210**. The reflected light beam (not labeled) is collimated by lens **210**, passes through beam splitter **212** and is deflected by mirror **214** along an axis parallel to the surface of sample **208**.

Since light beams **209** and **211** are parallel to each other and to the surface of sample **208**, the movement of the beam deflector **202** in the X direction does not affect the measurements of the detector unit **206**.

As in the embodiments of FIGS. **2** and **3**, a detector unit **206** typically comprises an imaging lens **218**, a diaphragm **220** having a pinhole **222** and a condenser **224**. Detector unit **206** additionally comprises a spectrophotometric detector **226**. Elements **218–224** reduce the scatter due to mirror **214** and provide a useful beam to the spectrophotometric detector **226**.

Reference is now made to FIG. **7** which illustrates a further embodiment of the present invention. In this embodiment, the beam deflector, labeled **300**, deflects beams for multiple optical assemblies towards a wafer **301**. FIG. **7** illustrate two optical assemblies, an ellipsometric assembly **302** and a spectrophotometric assembly **304**, one above the other. It will be appreciated that the order of the two assemblies is not of interest.

The spectrophotometric assembly **304** comprises, shown by a box labeled **306**, the entirety of optical and controlling elements needed for spectrophotometry, except those elements which deflect the light beam towards the wafer **301**. The details of the elements of box **306** have been provided hereinabove with respect to FIG. **6** and therefore, will not be described in detail herein. Spectrophotometric assembly **304**

also comprises a mirror **308** for deflecting a light beam, labeled **305**, from assembly **304** to the beam deflector **300** and vice versa.

The ellipsometric assembly **302** comprises an illuminator **310** and an analyzer **312**, similar in function to the illuminator **100** and analyzer **102** of FIG. **4**, and two mirrors **314** and **316** for respectively deflecting an input light beam **311** from illuminator **310** to the beam deflector **300** and an output light beam **313** from the beam deflector **300** to the analyzer **312**.

Below both assemblies **302** and **304** is a fixed input/output surface **320** on which are mounted an input mirror **330** and an output mirror **342**. The input and output mirrors **330** and **342**, respectively, deflect light beams into and out from the optical assemblies **302** and **304**.

Mechanically, the beam deflector **300** is similar to the beam deflector of FIG. **3** and comprises a translatable Y-axis stage **322** (shown in two sections **322a** and **322b**) and a translatable X-axis stage **324** which translates along the Y-axis stage **322**.

Optically, the beam deflector **300** comprises a Y-to-X mirror **332**, a spectrophotometry mirror **334**, an input ellipsometry mirror **336**, an output ellipsometry mirror **338** and an X-to-Y mirror **340**. The Y-to-X mirror **332** and X-to-Y mirror **334** are mounted on the separate sections of the Y-axis stage **322**, where the Y-to-X mirror **332** deflects input light beams from the Y to the X axis and the X-to-Y mirror **334** deflects output light beams from the X to the Y axis. The remaining elements are mounted on the X-axis stage and perform the actual optical measurement.

For the spectrophotometric measurements, light beam **305** is deflected by input mirror **330** in the Y direction along a first Y axis (not illustrated for clarity) towards the Y-to-X mirror **332** which, in turn, deflects the light beam, now labeled **350**, towards the spectrophotometric mirror **334**. Mirror **334** deflects the light beam **350** towards the wafer **301** at an angle perpendicular to the wafer **301**. The reflected light returns to mirror **334** and is reflected back through mirrors **332** and **330** to the spectrophotometric assembly **304**.

For the ellipsometric measurements, light beam **311** also is reflected by mirrors **330** and **332** towards the X-axis stage **324**. However, as shown in FIG. **7**, light beam **311** is reflected along second set of X and Y-axis (also not illustrated) close but parallel to the first set of axes along which the light beam **305** is reflected. Thus, the two light beams are deflected along parallel paths until reaching the X-axis stage **324**.

The input ellipsometry mirror **336** is positioned on the X-axis stage at the appropriate height above the wafer so as to receive "ellipsometric" light beam, labeled **351**, from the Y-to-X mirror **332**. Mirror **336** deflects beam **351** towards the wafer **301** so as to impinge upon wafer **301** at the appropriate angle α . The angle α , as shown in FIG. **7**, is the angle from the normal to the wafer **301**. The actual angle of incidence at the time of performing the measurements must be measured for proper ellipsometric measurements. The method described hereinabove with respect to FIG. **5C** can be utilized.

The reflected beam, labeled **353**, impinges upon mirror **338** and is deflected thereby towards X-to-Y mirror **340**. From mirror **340**, the output beam travels along the Y direction and is deflected by mirror **342** into the ellipsometric assembly **302**. Mirror **316**, in turn, directs the output beam into the analyzer **312** for processing.

It will be appreciated that the beam deflector **300** provides translation for the measuring optics of a multiplicity of

optical measuring units as a single unit. The type of measuring unit does not matter; rather, the optical paths at the point of measurement should not cross. In the embodiment of FIG. 7, the spectrophotometric measuring optics view the wafer perpendicularly to the wafer while the ellipsometric measuring optics view the wafer at an angle. The deflecting mirrors of the two measuring units can thus be combined together into a single, translatable unit.

It will be appreciated by persons skilled in the art that the present invention is not limited to what has been particularly shown and described hereinabove. Rather the scope of the present invention is defined by the claims which follow:

I claim:

1. A two-dimensional beam deflector for a thickness measuring device for measuring the thickness of films on a sample with a plurality of different optical systems each performing a different measurement technique, the beam deflector comprising:

two-dimensional translation means for translating said beam deflector along a first scanning axis and along a second scanning axis perpendicular to said first scanning axis;

first deflection means for receiving a plurality of parallel input beams along parallel input axes, said input axes being close to each other and parallel to said first scanning axis, and for deflecting said input beams along a plurality of parallel second axes, said second axes being close to each other and parallel to said second scanning axis;

second deflection means for receiving a plurality of parallel output beams along parallel third axes, said third axes being close to each other and parallel to said second axes, and for deflecting said output beams along a plurality of parallel fourth axes, said fourth axes being close to each other and parallel to said first scanning axis; and

a plurality of optical assemblies, one per input beam, wherein each optical assembly provides its input beam towards said sample, receives its output beam from said sample, processes its input and output beams in accordance with its measurement technique, and provides its output beams along said parallel third axes.

2. A beam deflector according to claim 1 and wherein said optical assemblies comprises at least an ellipsometric assembly and a spectrophotometric assembly.

3. A thickness measuring device for measuring the thickness of thin films on a sample with two measurement devices, the device comprising:

first and second stationary illuminators, one for each of said two measurement devices, for providing first and second collimated input light beams along first and second parallel input axes;

a beam deflector for directing said first and second input light beams toward said sample and for directing and collimating corresponding first and second output light beams from said sample, said beam deflector including two-dimensional translation means for translating said beam deflector along a first scanning axis parallel to said input axis, and along a second scanning axis perpendicular to said first scanning axis; and

first and second stationary receivers, one for each of said two measurement devices, for respectively receiving said first and second output light beams along output axes parallel to said input axes.

4. An ellipsometer for measuring the thickness of thin films on a sample comprising:

a stationary illuminator for providing a collimated input light beam along an input axis;

a beam deflector translatable at least along a first scanning axis parallel to said input axis including:

a first beam deflecting element for deflecting said input light beam at a first angle of deflection towards said sample;

a second beam deflecting element, different from said first beam deflecting element, for deflecting an output light beam reflected at a second angle from said sample along an output axis; and

a collimating lens for receiving at least said output light beam from said second beam deflecting element and for collimating at least said output light beam; and

a stationary receiver for receiving said collimated output light beam along an output axis parallel to said input axis.

5. A device according to claim 4 and wherein said beam deflector comprises two-dimensional translation means for translating said beam deflector along said first scanning axis and along a second scanning axis perpendicular to said first scanning axis.

6. A device according to claim 5 where said beam deflector additionally comprises a first mirror for deflecting said input light beam from said input axis to said second scanning axis, a second mirror for deflecting said input light beam from said second scanning axis to said sample, a third mirror for deflecting a reflected light beam reflected from said sample to said second scanning axis, and a fourth mirror for deflecting said reflected light beam from said second scanning axis to said output axis.

7. An ellipsometer for measuring the thickness of thin films on a sample comprising:

a stationary illuminator for providing a collimated input light beam along an input axis;

a beam deflector translatable at least along a first scanning axis parallel to said input axis including:

a first beam deflecting element for deflecting said input light beam at a first angle of deflection towards said sample;

a second beam deflecting element, different from said first beam deflecting element, for deflecting an output light beam reflected at a second angle from said sample along an output axis; and

a collimating lens for receiving at least said output light beam from said second beam deflecting element and for collimating at least said output light beam; and

a stationary receiver for receiving said collimated output light beam along an output axis parallel to said input axis,

wherein said beam deflector comprises on-dimensional translation means for translation along said scanning axis.

8. An ellipsometer for measuring the thickness of thin films on a sample comprising:

a stationary illuminator for providing a collimated input light beam along an input axis;

a beam deflector translatable at least along a first scanning axis parallel to said input axis including:

a first beam deflecting element for deflecting said input light beam at a first angle of deflection towards said sample;

a second beam deflecting element, different from said first beam deflecting element, for deflecting an output light beam reflected at a second angle from said sample along an output axis; and

15

- a collimating lens for receiving at least said output light beam from said second beam deflecting element and for collimating at least said output light beam; and
- a stationary receiver for receiving said collimated output light beam along an output axis parallel to said input axis, 5
- wherein said first and second beam deflecting elements are mirrors.
9. An ellipsometer for measuring the thickness of thin films on a sample comprising: 10
- a stationary illuminator for providing a collimated input light beam along an input axis;
- a beam deflector translatable at least along a first scanning axis parallel to said input axis including: 15
- a first beam deflecting element for deflecting said input light beam at a first angle of deflection towards said sample;
- a second beam deflecting element, different from said first beam deflecting element, for deflecting an output light beam reflected at a second angle from said sample along an output axis; and 20
- a collimating lens for receiving at least said output light beam from said second beam deflecting element and for collimating at least said output light beam; and 25
- a stationary receiver for receiving said collimated output light beam along an output axis parallel to said input axis,
- wherein said first beam deflecting element is a beam splitter and said second beam deflecting element is a mirror. 30
10. An ellipsometer for measuring the thickness of thin films on a sample comprising:
- a stationary illuminator for providing a collimated input light beam along an input axis; 35
- a beam deflector translatable at least along a first scanning axis parallel to said input axis including:
- a first beam deflecting element for deflecting said input light beam at a first angle of deflection towards said sample; 40
- a second beam deflecting element, different from said first beam deflecting element, for deflecting an output light beam reflected at a second angle from said sample along an output axis; and 45
- a collimating lens for receiving at least said output light beam from said second beam deflecting element and for collimating at least said output light beam; and
- a stationary receiver for receiving said collimated output light beam along an output axis parallel to said input axis, 50
- and also including means for measuring an actual angle of incidence which may vary from said second angle of deflection, wherein said means for measuring utilizes optical elements forming part of said stationary illuminator and stationary receiver. 55
11. A device according to claim 10 and wherein said means for measuring comprises a position sensing device for measuring the angle of said output light beam with respect to a desired position. 60
12. A processing apparatus for processing a semiconductor sample, the apparatus comprising:
- (a) a processing unit comprising several chambers for processing of a top layer of the sample under certain vacuum conditions within a working area inside the processing unit; 65

16

- (b) an optical monitoring station associated with said processing unit and defining a monitoring area in one of the chambers outside said working area, said one of the chambers having an optical window through which at least a portion of said top layer of the sample is observable from outside of the chamber; and
- (c) a robot for transferring said sample from said working area to said monitoring area without breaking the vacuum conditions;
- wherein said optical monitoring station comprises an optical monitoring unit operable to scan at least a portion of the sample through said optical window, and comprises a two-dimensional beam deflector accommodated outside said at least one of the chambers, and operable for monitoring the thickness of said at least top layer of the sample through said optical window, while the sample is located inside said chamber under certain vacuum conditions; 5
- wherein the two-dimensional beam deflector comprises a plurality of different optical systems each performing a different monitoring technique, the beam deflector comprising:
- two-dimensional translation means for translating said beam deflector along a first scanning axis and along a second scanning axis perpendicular to said first scanning axis;
- first deflection means for receiving a plurality of parallel input beams along parallel input axes, said input axes being close to each other and parallel to said first scanning axis, and for deflecting said input beams along a plurality of parallel second axes, said second axes being close to each other and parallel to said second scanning axis;
- second deflection means for receiving a plurality of parallel output beams along parallel third axes, said third axes being close to each other and parallel to said second axes, and for deflecting said output beams along a plurality of parallel fourth axes, said fourth axes being close to each other and parallel to said first scanning axis; and 10
- a plurality of optical assemblies, one per input beam, wherein each optical assembly provides its input beam towards said sample, receives its output beam from said sample, processes its input and output beams in accordance with its measurement technique, and provides its output beams along said parallel third axes.
13. A processing apparatus according to claim 12, wherein said optical assemblies comprise at least an ellipsometric assembly and a spectrophotometric assembly.
14. A processing apparatus for processing a semiconductor sample, the apparatus comprising:
- (a) a processing unit comprising several chambers for processing of a top layer of the sample under certain vacuum conditions within a working area inside the processing unit;
- (b) an optical monitoring station associated with said processing unit and defining a monitoring area in one of the chambers outside said working area, said one of the chambers having an optical window through which at least a portion of said top layer of the sample is observable from outside of the chamber; and
- (c) a robot for transferring said sample from said working area to said monitoring area without breaking the vacuum conditions; 15
- wherein said optical monitoring station comprises an optical monitoring unit accommodated outside said at

17

least one of the chambers, and operable for monitoring the thickness of said at least top layer of the sample through said optical window, while the sample is located inside said chamber under certain vacuum conditions; 5

wherein said optical monitoring unit comprises two monitoring devices, each device comprising:

first and second stationary illuminators, one for each of said two measurement devices, for providing first and second collimated input light beams along first and second parallel input axes; 10

a beam deflector for directing said first and second input light beams toward said sample and for directing and collimating corresponding first and second output light beams from said sample, said beam deflector including two-dimensional translation means for translating said beam deflector along a first scanning axis parallel to said input axis, and along a second scanning axis perpendicular to said first scanning axis; and 15

first and second stationary receivers, one for each of said two measurement devices, for respectively receiving said first and second output light beams along output axes parallel to said input axes.

15. A process apparatus for processing a semiconductor sample, the apparatus comprising: 25

(a) a processing unit comprising several chambers for processing of a top layer of the sample under certain vacuum conditions within a working area inside the processing unit; 30

(b) an optical monitoring station associated with said processing unit and defining a monitoring area in one of the chambers outside said working area, said one of the chambers having an optical window through which at least a portion of said top layer of the sample is observable from outside of the chamber; and 35

(c) a robot for transferring said sample from said working area to said monitoring area without breaking the vacuum conditions; 40

wherein said optical monitoring station comprises an optical monitoring unit operable to scan at least a portion of the sample through said optical window, accommodated outside said at least one of the chambers, and operable for monitoring at least one desired parameter of said at least top layer of the sample through said optical window, while the sample is located inside said chamber under certain vacuum conditions; 45

wherein said optical monitoring unit additionally comprises an ellipsometer, said ellipsometer comprising: 50

a stationary illuminator for providing a collimated input light beam along an input axis;

18

a beam deflector translatable at least along a first scanning axis parallel to said input axis including: 5

a first beam deflecting element for deflecting said input light beam at a first angle of deflection towards said sample;

a second beam deflecting element, different from said first beam deflecting element, for deflecting an output light beam reflected at a second angle from said sample along an output axis; and

a collimating lens for receiving at least said output light beam from said second beam deflecting element and for collimating at least said output light beam and

a stationary receiver for receiving said collimated output light beam along an output axis parallel to said input axis.

16. A process apparatus according to claim 15, wherein said beam deflector comprises two-dimensional translation means for translating said beam deflector along said first scanning axis and along a second scanning axis perpendicular to said first scanning axis. 20

17. A processing apparatus according to claim 16, wherein said beam deflector additionally comprises a first mirror for deflecting said input light beam from said input axis to said second scanning axis, a second mirror for deflecting said input light beam from said second scanning axis to said sample, a third mirror for deflecting a reflected light beam reflected from said sample to said second scanning axis, and a fourth mirror for deflecting said reflected light beam from said second scanning axis to said output axis. 30

18. A processing apparatus according to claim 15, wherein said beam deflector comprises one-dimensional translation means for translation along said scanning axis. 35

19. A processing apparatus according to claim 15 wherein said first and second beam deflecting elements are mirrors.

20. A process apparatus according to claim 15 wherein said first beam deflecting element is a beam splitter and said second beam deflecting element is a mirror. 40

21. A processing apparatus according to claim 15 further comprising means for measuring an actual angle of incidence which may vary from said second angle of deflection, wherein said means for measuring utilizes optical elements forming part of said stationary illuminator and stationary receiver. 45

22. A processing apparatus according to claim 21, wherein said means for measuring comprises a position sensing device for measuring the angle of said output light beam with respect to a desired position. 50

* * * * *

UNITED STATES PATENT AND TRADEMARK OFFICE
CERTIFICATE OF CORRECTION

PATENT NO. : RE 38,153 E
APPLICATION NO. : 09/557938
DATED : June 24, 2003
INVENTOR(S) : Moshe Finarov

Page 1 of 1

It is certified that error appears in the above-identified patent and that said Letters Patent is hereby corrected as shown below:

Insert in the first sentence of the specification as follows:

Notice: More than one reissue application has been filed for the reissue of patent 5,764,365. The reissue applications are application Ser. No. 09/557,938 (the present application) filed 4/24/2000 and application Ser. No. 10/284,308. Application Ser. No. 10/284,308 is continuation of application Ser. No. 09/577,939.

Signed and Sealed this

Twenty-sixth Day of June, 2007

A handwritten signature in black ink on a light gray dotted background. The signature reads "Jon W. Dudas" in a cursive style.

JON W. DUDAS

Director of the United States Patent and Trademark Office