



US00RE38118E

(19) **United States**
(12) **Reissued Patent**
Townsend

(10) **Patent Number: US RE38,118 E**
(45) **Date of Reissued Patent: May 13, 2003**

(54) **LATH FOR LUMBER STACKING**

(75) Inventor: **David M. Townsend, Langton (CA)**

(73) Assignee: **Breeze Dried, Inc., Ontario (CA)**

(21) Appl. No.: **09/703,926**

(22) Filed: **Nov. 2, 2000**

2,907,359 A	*	10/1959	Lade	144/136.1
3,651,842 A	*	3/1972	McLean	144/136.1
3,907,130 A	*	9/1975	Hutchenson	34/94
3,994,326 A	*	11/1976	Sarten	144/136.1
4,246,943 A	*	1/1981	Cromeens	144/246.1
4,372,357 A	*	2/1983	Steiling	144/114
4,788,777 A	*	12/1988	Davis	34/518 X
4,842,029 A	*	6/1989	De Abreu	144/117.1
4,993,464 A	*	2/1991	Englert	144/136.1
5,345,695 A	*	9/1994	Graham	34/94

Related U.S. Patent Documents

Reissue of:

(64) Patent No.: **5,813,137**
Issued: **Sep. 29, 1998**
Appl. No.: **08/566,733**
Filed: **Dec. 4, 1995**

(30) **Foreign Application Priority Data**

Aug. 23, 1995 (CA) 2156761

(51) **Int. Cl.**⁷ **F26B 3/00**

(52) **U.S. Cl.** **34/518; 34/94; 248/346.01; 248/346.02**

(58) **Field of Search** 34/518, 94; 248/346.01, 248/346.02; 414/789.5; 52/740.3, 733.3, 740.1, 740.2, 740.4, 740.5, 740.6, 740.7; 211/60.1, 59.4; 108/51.1, 53.1

(56) **References Cited**

U.S. PATENT DOCUMENTS

595,895 A	*	12/1897	Solomon	211/60.1 X
658,913 A	*	10/1900	Hass	34/94
851,789 A	*	4/1907	Alexander	34/94
867,090 A	*	4/1907	Wolf	52/740.2
1,023,149 A	*	4/1912	Havemeyer	52/740.2
1,052,683 A	*	2/1913	McDonald	52/740.2
1,280,046 A	*	9/1918	Kuhne	52/740.2
1,963,242 A	*	6/1934	Nelson	248/346.01 X
2,679,111 A	*	5/1954	Leischner	34/94
2,870,806 A	*	1/1959	Thompson	144/136.1

FOREIGN PATENT DOCUMENTS

DE	715251	*	11/1941	
DE	C715251	*	11/1941	
DE	829425	*	7/1950	
DE	C829425	*	12/1951	
DE	134625	*	3/1979 248/346.02
FR	130898	*	7/1962	
FR	A1300898	*	12/1962	

* cited by examiner

Primary Examiner—Ramon O. Ramirez

(74) *Attorney, Agent, or Firm*—Pillsbury Winthrop LLP

(57) **ABSTRACT**

This invention relates to an improved separator, commonly referred to as a “lath”, “stick”, “sticker”, or “crosser”, that is used in the lumber industry to separate pieces of lumber in a stack or bundle. The separator features, in one embodiment, a plurality of grooves extending transverse to the length of the separator to permit air circulation within the grooves, and a plurality of ridges between the grooves to support the pieces of lumber. In another embodiment, a second plurality of grooves extending transverse to the length of the separator and the first groove to form a cross-hatching of grooves to permit air circulation within the grooves, and a plurality of protrusions to support the pieces of lumber over the grooves.

37 Claims, 4 Drawing Sheets

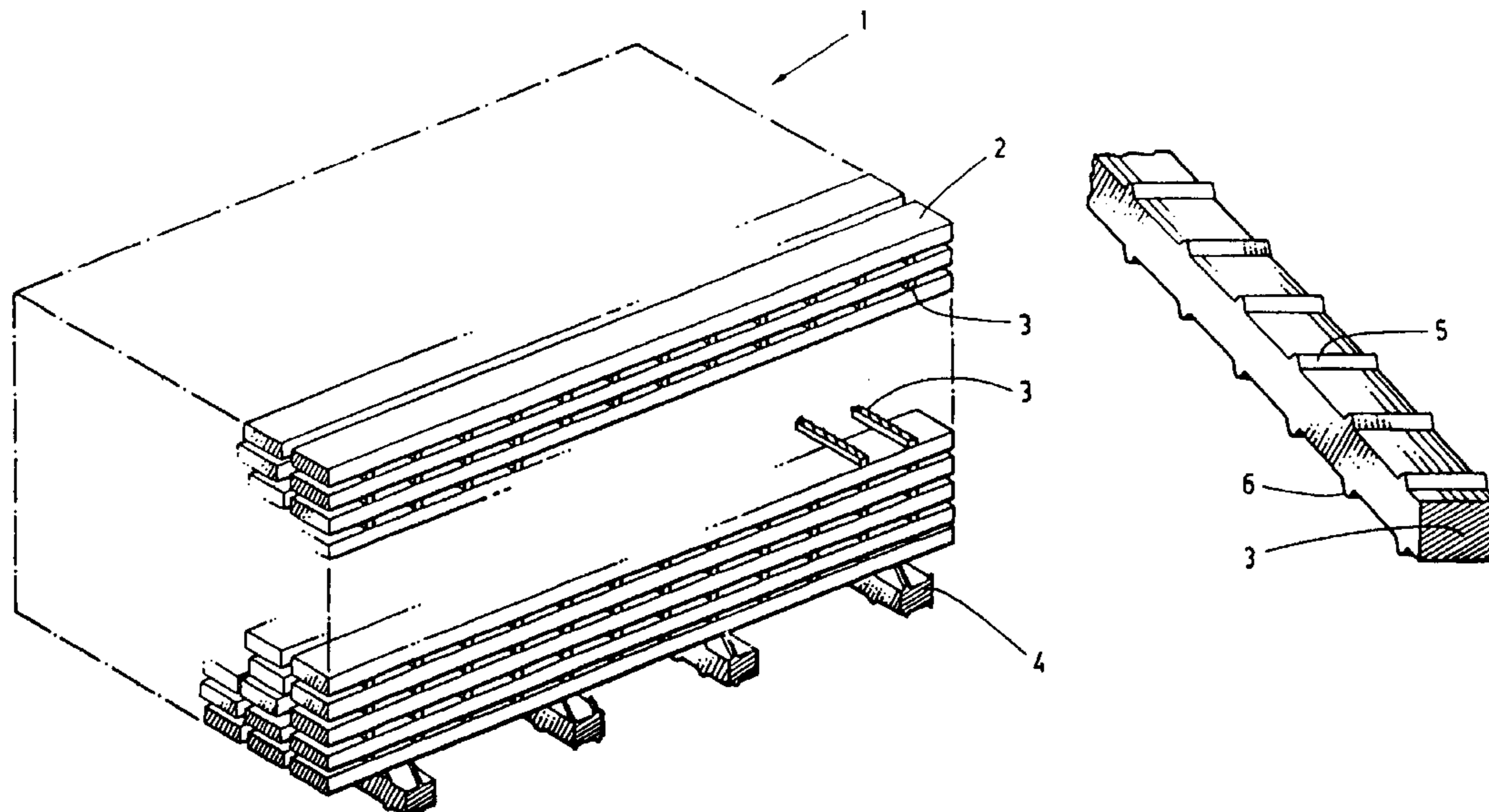

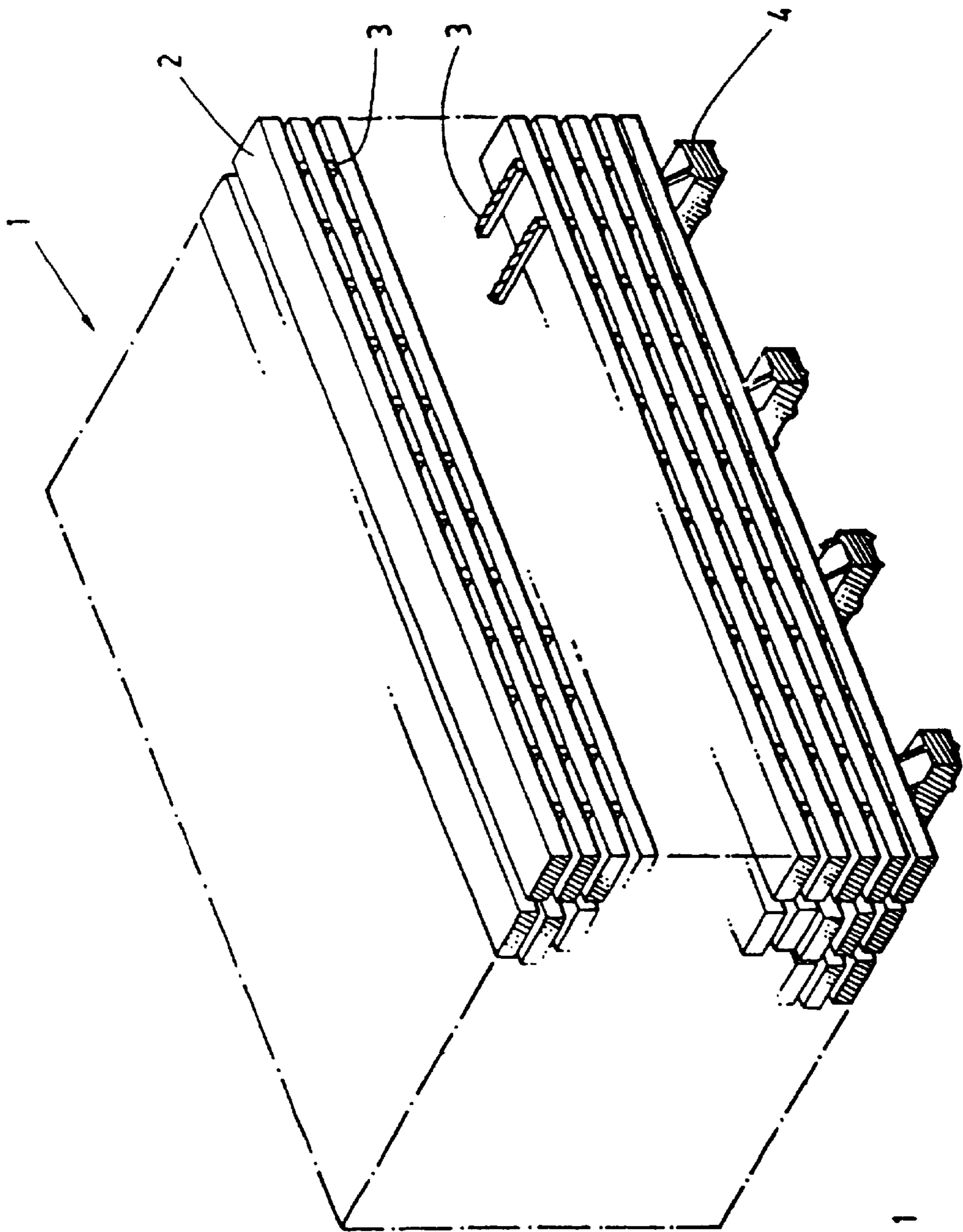

FIG. 1

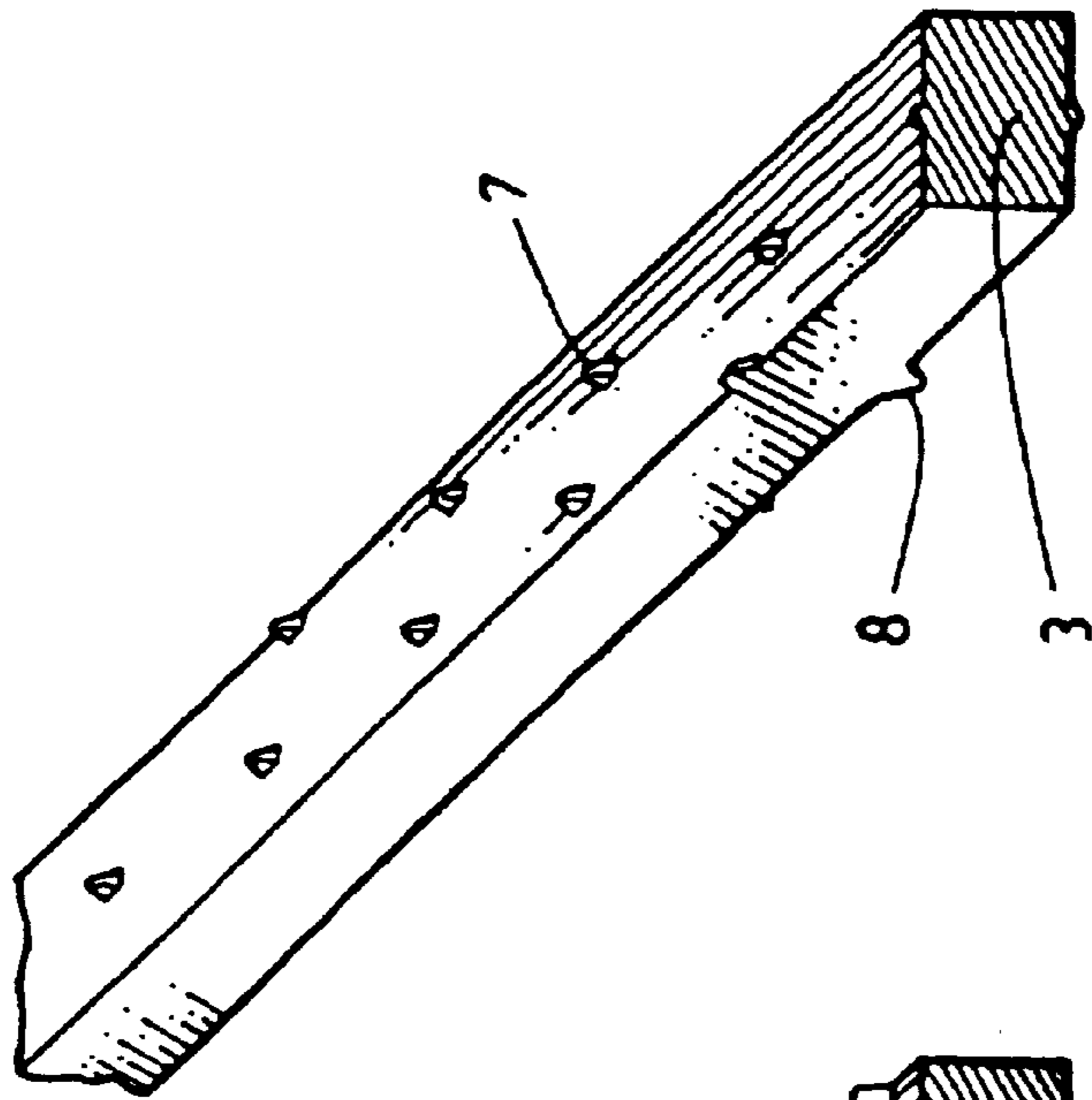

FIG. 4

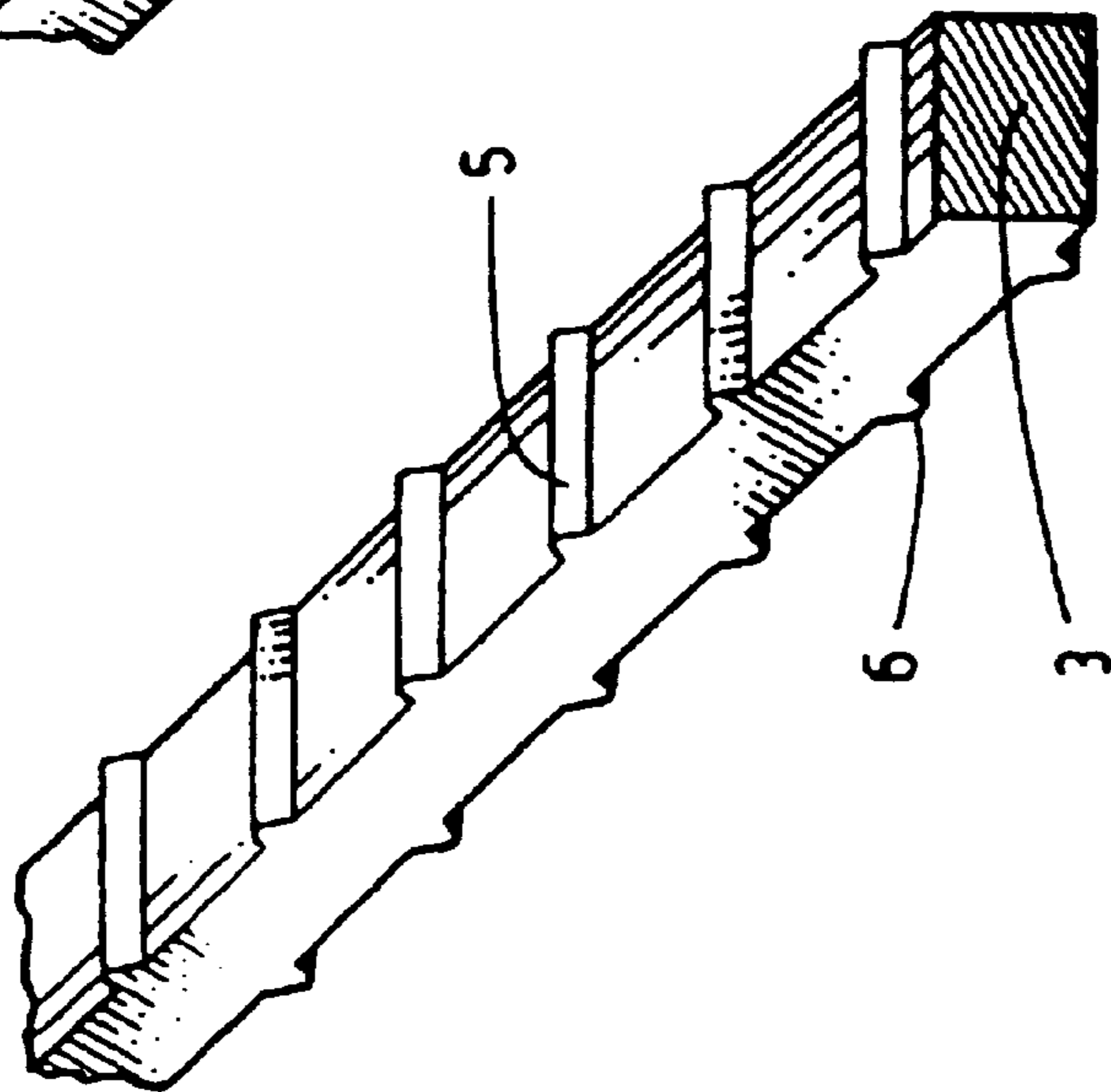

FIG. 3

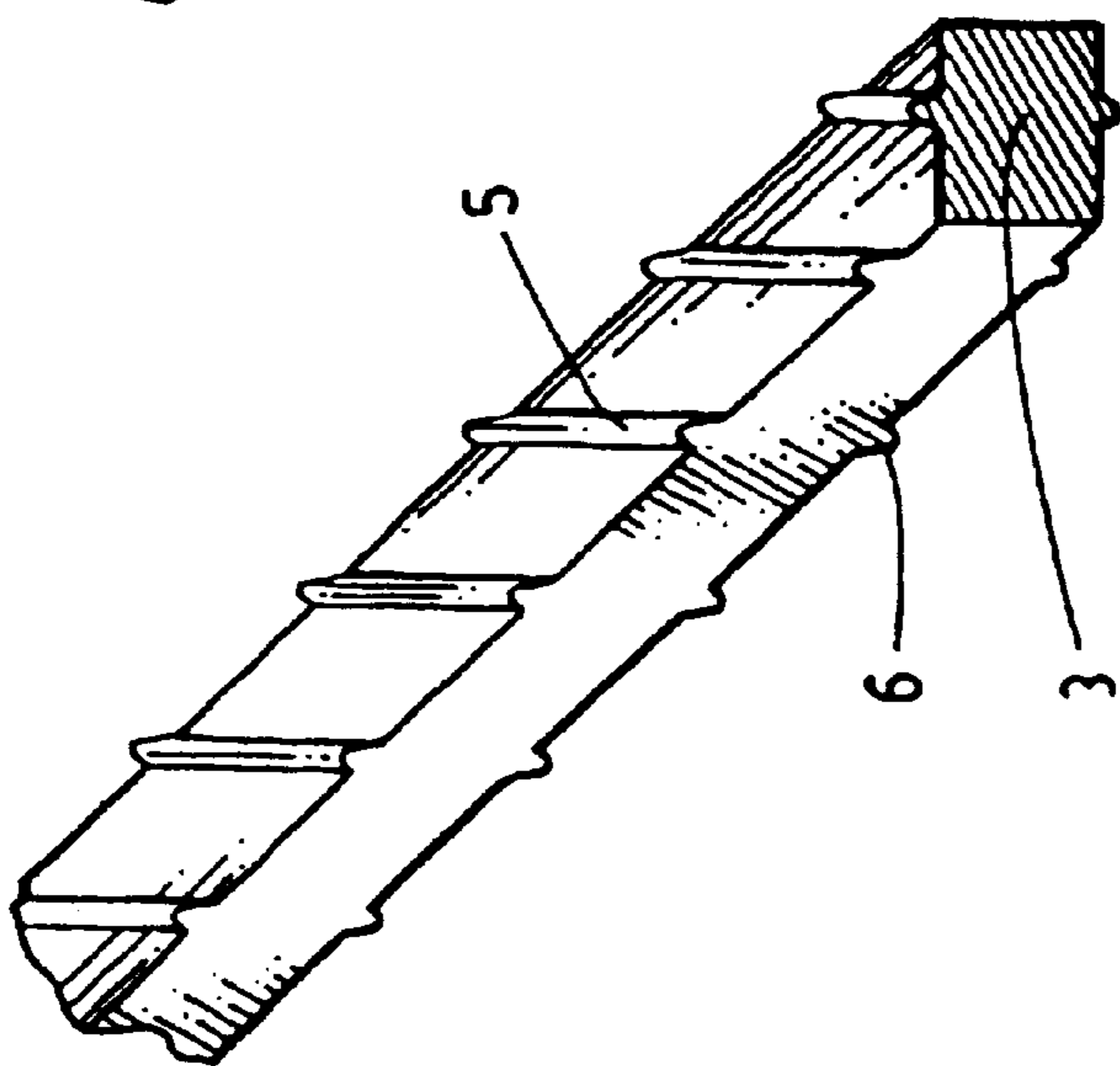

FIG. 2

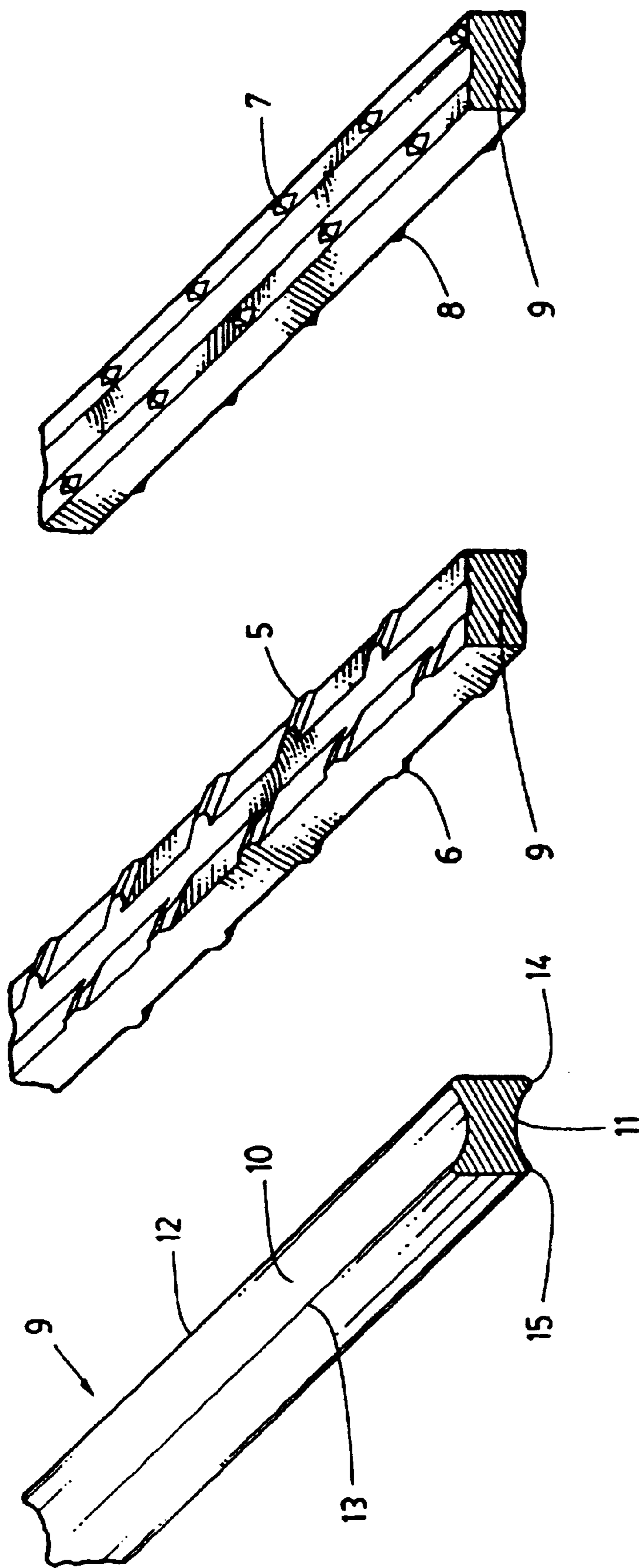

FIG. 7

FIG. 6

FIG. 5
(PRIOR ART)

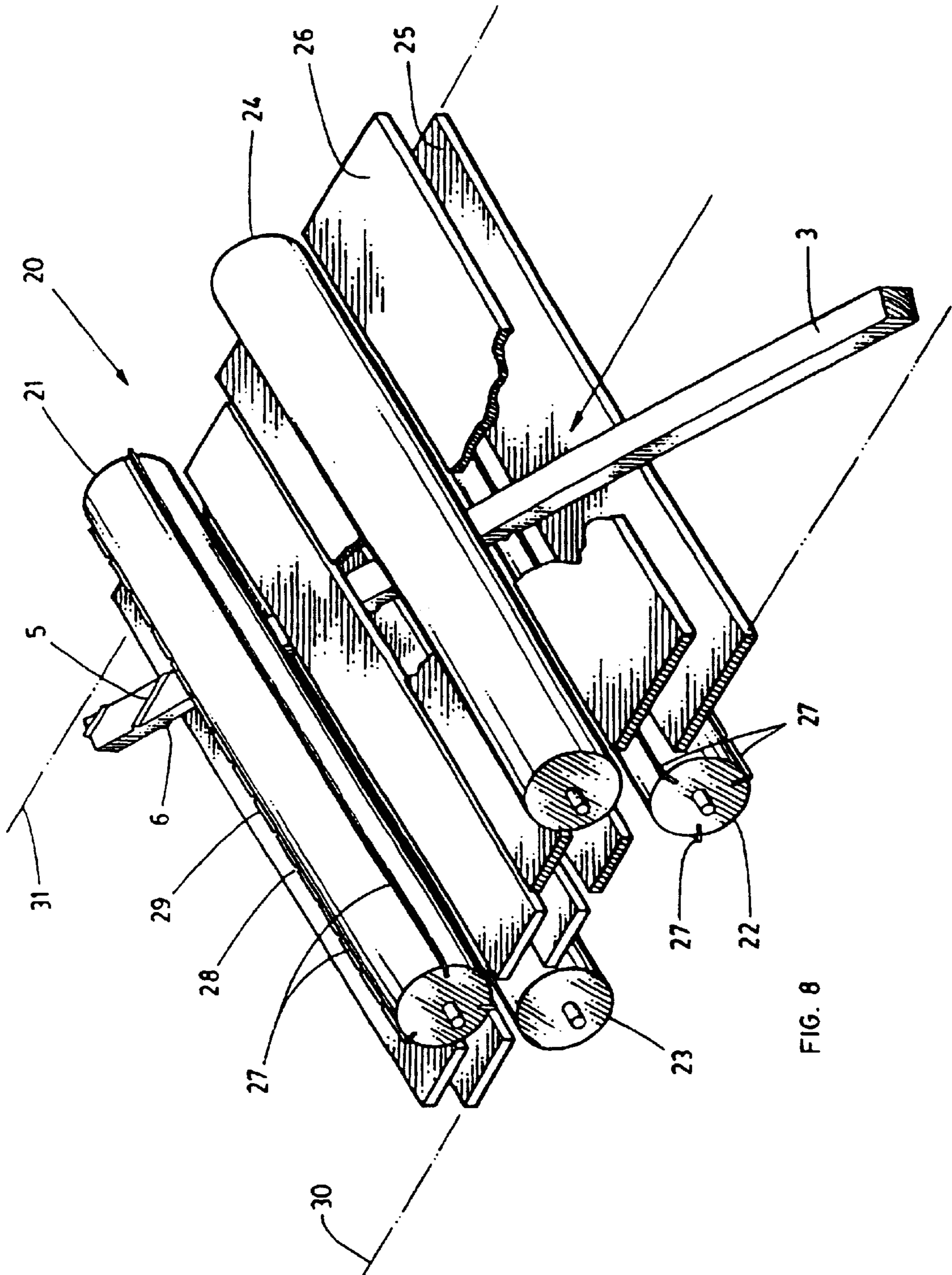

FIG. 8

LATH FOR LUMBER STACKING

Matter enclosed in heavy brackets [] appears in the original patent but forms no part of this reissue specification; matter printed in italics indicates the additions made by reissue.

BACKGROUND OF THE INVENTION

This invention relates a device that is commonly referred to as a "lath", "stick", "sticker", or "crosser" (referred to here as a "separator") that is used in the lumber industry to separate pieces of lumber in a stack, bundle or lift or the like (hereafter referred to as a "stack"). More particularly, the invention relates to an improvement in such a lath to augment air circulation within a lumber stack and to reduce staining of lumber.

In the lumber industry timber is cut into boards or lumber which are usually stacked in a shed or kiln to dry before shipping. Stacking may also be used to maintain lumber during shipping or storage. The boards in a stack are usually separated by separators running transversely to the length of the boards. An individual stack is often built up to a height of about 5 feet with the boards laid in a spaced and parallel relationship in courses, course upon course, with separators laid between the courses across the boards. Individual stacks may be piled on one another to create larger stacks for efficient storage using spacer blocks between the individual stacks. The spacer blocks are usually larger than a common separator lath (4"x4" as opposed to 1"x1") but are usually made of the same material, ie. low grade lumber such as spruce. The difference in size of the separators is not material to this invention. Therefore, spacer blocks are also included within the meaning of the term separator, where the context permits, in this specification. Drying air circulates in the spaces between the boards in each course and in the spaces provided by the separators between the boards of adjacent courses and between individual stacks.

An imprint or stain, sometimes called a "shadow" or "sticker stain", may be left on a board in an area where it has been in contact with a separator in a stack. Such staining may be partly due to the percolation of sugars and other chemicals from the separators to the lumber. It is also understood that staining may result from the fact that air cannot penetrate to the board surface covered by a separator to dry the wood and mould or spores grow in the residual moisture. A stain may be visible immediately after removal of a board from the stack or it may show later during finishing or staining of the wood. It renders lumber unmerchantable for certain end uses and sometimes is the cause of costly claims to mills from customers. It is a significant problem in the lumber industry, particularly with light coloured woods.

Attempts to solve this problem have been directed at minimizing the contact area between a separator and the lumber in a stack. For example, U.S. Pat. No. 3,907,130 entitled "KILN STICKER" that issued to D. Hutcheson on Sep. 23, 1975, disclosed a plastic separator for drying wood with a curved upper surface and a lengthwise groove along its bottom surface to reduce the area of contact. One disadvantage of this design is that a lengthwise groove does not facilitate circulation of air through the groove. End to end circulation along the long length of a separator through a small cross section groove is inefficient. Consequently, the groove provides a protected area for mould and spores to cultivate. Another disadvantage is that equipment for manufacturing plastic separators is foreign to a lumber mill so a

mill would need to buy prefabricated plastic separators from a remote factory. Manufacturing costs, transportation costs, availability, maintaining separator inventory at a mill and other factors augured against use of plastic separators and they did not replace the more common and readily available wooden separators.

Nevertheless, the lengthwise groove design to reduce contact area was adopted in the industry, but in wooden separators. It is not uncommon now to find wooden separators cut with top and bottom lengthwise grooves forming an "H" shaped cross section. The "H" separator reduces contact area and utilizes the wood resources of a mill but suffers the same disadvantage of poor air circulation along the long narrow grooves. The manufacture of such wooden separators may use equipment ordinary to a mill, but cutting lengthwise grooves requires close tolerances and straight separators to maintain the alignment of a groove to the long axis of a narrow separator. Further, manufacturing many separators may require many tools or many runs through the same tools.

It is an object of this invention to provide an improved separator for separating lumber that provides reduced contact area between the separator and the lumber, improved air circulation and permits simple manufacture without close tolerances using equipment commonly found at a mill. It is also an object of this invention to disclose elements to adapt a common plane or other apparatus to manufacture such improved separators. The disclosure of the invention is made in terms of wooden separators, because these are believed to be best suited to the lumber industry, but it will be appreciated by skilled persons that this disclosure is also suitable to and intended for separators manufactured from other suitable materials such as plastic except that the preferred manufacturing process may be unsuitable for some other materials.

GENERAL DESCRIPTION OF THE INVENTION

The improved separator of this invention comprises a separator having a length to span across one or more pieces of lumber in a course and a height to separate the courses sufficiently for air circulation between the courses and having a plurality of grooves traversing the length of the separator to permit air circulation within the grooves. Since the grooves run across a short width of a separator rather than along its length, air circulation through the grooves is much improved over the prior art long groove separators. The grooves may run perpendicularly to the length of the separator or, diagonally, at an angle to the length. The spacing between grooves is not critical although close spacing reduces the contact area between grooves. In a preferred embodiment, the grooves are spaced to present sharp peaks between them thus minimizing the contact area with the lumber. In a preferred embodiment, grooves are cut with sharp peaks spaced about $\frac{3}{4}$ of an inch and at a 60° angle to the long axis of the separator. Similar grooves are cut in the top and the bottom surfaces of the separator to touch the boards in the lumber stack. In another embodiment, grooves are cut at a 60° angle to the longitudinal axes of the separator in one direction and then cut again in an opposite direction to provide intersecting grooves. The ridges between the first run of grooves are cut by the traversing set of second grooves resulting in diamond shaped protrusions which further reduce the amount of surface area in contact with the lumber and provides for additional circulation. It will be appreciated that separator size, groove spacing and contact area should be sufficient to support the weight of the stack without denting the lumber

to render it unmerchantable, but this aspect of design is within the skill of the art and will not be discussed in detail in this specification. It is similar to the design of a bed of nails that supports a heavy body with a delicate surface on sharp points on the principle that many points will support the weight of the body with little pressure on each point.

Manufacture of such separators is relatively easy. Since the grooves run transversely to the length of the separator there is no difficulty aligning the narrow separator to a tool during manufacture. Close tolerances are not necessary nor are multiple tools required. The separators may be cut in an ordinary plane fitted with a serrated blade that forms grooves and peaks as separators are passed sideways through the plane. The angle at which the separators pass through the plane determines the angle of the grooves to the long axis of the separator. The angle is not critical nor is consistency of the angle between separators, thus it is unnecessary to maintain close tolerances in the feeding process. The manufacture also has the advantage that it can be used to clean and renew old dirty separators for reuse as improved separators of this invention. Thus it is not necessary for a lumber mill to discard its inventory of separators to use this invention.

DESCRIPTIONS OF THE FIGURES

In the figures which illustrate a preferred embodiment of this invention:

FIG. 1 is a perspective view of a stack of lumber separated by separators;

FIG. 2 is a perspective view of an improved separator having diagonal grooves;

FIG. 3 is a perspective view of an improved separator having grooves at right angles to the long axis of the separator;

FIG. 4 is a perspective view of an improved separator having two sets of transverse diagonal grooves on each of its top and bottom surfaces;

FIG. 5 is an "H" shaped separator of the prior art;

FIG. 6 is a perspective view of an H-shaped separator modified to become an improved separator of this invention;

FIG. 7 is a perspective view of an H-shaped separator modified to become an improved separator of this invention having intersecting grooves; and

FIG. 8 is a partial view of a plane fitted with a serrated blade to manufacture separators of this invention.

DESCRIPTION OF THE PREFERRED EMBODIMENTS

FIG. 1 illustrates a stack 1 comprising boards 2 laid in courses upon separators (laths) 3. The stack 1 is supported upon separators (blocks) 4. Other similarly constructed stacks may be placed upon stack 1 to create a larger stack, tens of feet high. The stack 1 is constructed for the purpose of air drying the boards or maintaining a dry condition. The lath separators 3 and the block separators 4 shown in FIG. 1 have diagonal grooves and ridges to reduce the amount of the separator in contact with the boards and to provide easy access for air circulation.

FIG. 2 illustrates a preferred embodiment of the improved separator 3 of this invention having diagonal ridges 5 on its top surface and similar diagonal ridges 6 on its bottom surface. There is no specific angle at which the ridges 5 or 6 must cross the length of the separator 3 in order to be effective for the purposes of this invention. The ridges 5 may run at a different angle to the ridges 6 and it is not critical

to this invention that the ridges 5 are each exactly parallel to one another or that the ridges 6 are each exactly parallel to one another. The main objective are to obtain numerous short grooves to facilitate air circulation and sufficient ridges to support the lumber. However, parallel grooves and ridges on each surface are likely to result from mass manufacturing techniques described hereafter.

FIG. 3 illustrates another example of an improved separator of this invention in which the ridges 5 and 6 are cut perpendicular to the length of the separator. This might be an ideal cut for it will have the shortest grooves to permit good air circulation and the shortest ridges in contact with the lumber, but it is unlikely to result from the manufacture described hereafter unless guides are used to closely control the feeding of separators to the plane. It is not necessary to do this to obtain the utility of the invention.

FIG. 4 illustrates a different embodiment of this invention in which each separator 3 is passed through the cutting tool twice on each side in opposite directions so that on the first pass a ridge 5 will be formed whereas on the second pass a protrusion 7 will remain being the intersection point of two such ridges 5 on the same surface. Similarly, protrusions 8 may be formed on the bottom surface.

FIG. 5 illustrates a prior art H-shaped separator 9 which has grooves 10 and 11 cut along its top and bottom surfaces centrally and parallel to the long axis of the separator 9. A separator of this construction reduces contact with the lumber because the upward protruding ridges 12 and 13 and the corresponding lower ridges 14 and 15 are the only contact with the lumber. But air circulation through the long grooves 10 and 11 is inefficient.

FIGS. 6 and 7 illustrate that an H-shaped separator may be adapted to become an improved separator of this invention. FIG. 6 illustrates the H-shaped separator 9 of FIG. 5 after having diagonal ridges 5 and 6 cut in its top and bottom surfaces through its ridges 12, 13, 14 and 15. FIG. 7 illustrates the H-shaped separator 9 after having two intersecting ridges 5 cut through the ridges 12, 13, 14 and 15 on its top and bottom surfaces to form protrusions 7 and 8.

FIG. 8 illustrates a planing machine ("plane") 20 having a top cutting drum 21 and a bottom cutting drum 22 and drums 23 and 24, respectively, in opposition to cutting drums 21 and 22. A bottom plane surface 25 and a top plane surface 26 form a structure for sliding a separator 3 into the plane 20 for cutting. Each of the cutting drums 21 and 22 is fitted with cutting blades 27 in a conventional manner. Each blade 27 is serrated with indentations 28 and protrusions 29. The protrusions 29 cut into a separator 3 to form the grooves between the ridges while the indentations 28 form the profile of each ridge. It will be appreciated that the grooves between ridges and the profile of the ridges may be adjusted by altering the shape of the indentations 28 and the protrusions 29. As illustrated in FIG. 2, the ridges 5 may have a curved profile; as illustrated in FIG. 3, a triangular profile; or, as illustrated in FIG. 6, a trapezoid profile. The particular shape of the profile is not material to the broad principle of this invention but may be relevant to support or air flow design for particular uses. It may also be appreciated that the ridges may not all have exactly the same profile because of the irregularities in the wood or in the cutting tool. Some ridges may have a triangular profile while others on the same separator may have a trapezoid profile because of irregularity in the surface of the wood limits the exposure to the cutting tool. Essentially the groove and ridge design will depend upon providing sufficient ridge depth to permit air to circulate between the separator 3 and a board 2 and provid-

5

ing a shape that will minimize surface contact while providing sufficient support for the lumber in the stack and to avoid denting of the boards **2** by the ridges **5** or **6**. It has been found that $\frac{5}{8}$ of an inch between ridges **5** or **6** and a ridge height of about $\frac{1}{8}$ of an inch with a triangular profile is suitable.

The embodiments of FIGS. **2**, **3** and **6** may be constructed by passing a separator through a plane to cut ridges **5** and **6** in its top and bottom surfaces. The angle of the ridges to the length of the separator will be limited in one direction by the outside guides **30** and **31** of the plane and the length of the separator. Where separators are shorter than the distance between the outside guides **30** and **31**, the angle of the cuts is at the discretion of the operator.

The embodiments in FIGS. **4** and **7** may be constructed by passing a separator through the plane **20** twice in opposition directions to make opposing cuts to form the protrusions **7** and **8**. It is not critical to this invention that the opposing cuts be made at any particular angle to one another, however, it will be appreciated that each of the opposing cut should transverse the other at a sufficient angle to leave adequate material to form protrusions **7** and **8**. Similar comments may be made about the profile of protrusions **7** and **8** as were made about the ridges **5** and **6**.

In the manufacturing operation, many separators may be placed side by side and passed through the planar **20**. It will be appreciated that one of the advantages of this invention is the low requirement for close tolerances. The angle of entry of a separator into the planar **20** is not critical as long as the cut is transverse to the length of the separator. It is also not critical that the ridges of one separator be parallel to the ridges of another separator. Moreover, manufacturing tolerances are quite wide. Accordingly, rough and ready manufacture of the improved separator of this invention is possible in a lumber yard.

The preferred method of manufacturing the improved separator of this invention comprises the steps of fitting serrated cutters into the cutting drums of a conventional planing machine, feeding separators through the plane and using the serrated blades to cut grooves and ridges in the top and/or bottom surfaces of the separator.

The description of the preferred embodiments of this invention is not intended to limit the general scope of the principle of this invention as it will be appreciated by a person skilled in the art and having read the disclosure and the claims as a whole.

I claim:

1. An improved separator for separating lumber in a stack up of a plurality of courses of lumber, said separator having:

a length, a height, and a width, the length being substantially longer than the width and spanning across one or more pieces of lumber in a course, and the height being sufficient to separate a pair of courses in the stack for air circulation therebetween;

a plurality of grooves extending transverse to the length of the separator; and

a plurality of ridges, with each ridge formed between a successive pair of grooves and presenting a peak to reduce contact of the separator with one or more pieces of lumber in a course; the ridges having a height sufficient to permit air circulation within each groove defined between successive pairs of ridges.

2. An improved separator of claim **1** in which the grooves and ridges run at an angle between 20° and 90° to the length of the separator.

3. An improved separator according to claim **1** wherein said separator is generally H-shaped in transverse, cross-section taken across the width of the separator.

6

4. An improved separator according to claim **1** wherein each of said plurality of ridges has a substantially solid cross-section.

5. An improved separator of claim **1** wherein said ridges present a curved profile.

6. An improved separator of claim **1** wherein said ridges present a triangular profile.

7. An improved separator of claim **1** wherein said ridges present a trapezoid profile.

8. An improved separator of claim **1** wherein said separator is manufactured from wood.

9. An improved separator for separating lumber in a stack made up of a plurality of courses of lumber, said separator having:

a length, a height, and a width, the length being substantially longer than the width and spanning across one or more pieces of lumber in a course, the height being sufficient to separate a pair of courses in the stack for air circulation therebetween;

a plurality of first grooves extending transverse to the length of the separator in one direction; and

a plurality of second grooves extending transverse to both the length of the separator and the first grooves;

said plurality of first grooves and said plurality of second grooves forming a plurality of protrusions for contacting one or more pieces of lumber in a course, the protrusions having a height sufficient to permit air circulation within said grooves.

10. In combination, a stack made up of a plurality of courses of lumber and a separator separating a spaced apart pair of said courses, said separator having:

a length, a height, and a width, the length being substantially longer than the width and spanning across one or more pieces of lumber in one of said courses, the height being sufficient to separate said spaced apart pair of said courses in the stack for air circulation therebetween;

a plurality of grooves extending transverse to the length of the separator; and

a plurality of ridges, with each ridge formed between a successive pair of grooves and presenting a peak to reduce contact of the separator with one or more pieces of lumber in a course, the ridges having a height sufficient to permit air circulation within each groove defined between successive pairs of ridges.

11. The combination of claim **10** in which the grooves and ridges run at an angle between 20° and 90° to the length of the separator.

12. The combination of claim **10** wherein said separator is generally H-shaped in transverse cross-section taken across the width of the separator.

13. The combination of claim **10** wherein each of said plurality of ridges has a substantially solid cross-section.

14. The combination of claim **10** wherein said ridges present a curved profile.

15. The combination of claim **10** wherein said ridges present a triangular profile.

16. The combination of claim **10** wherein said ridges present a trapezoid profile.

17. The combination of claim **10** wherein said separator is manufactured from wood.

18. In combination, a stack made up of a plurality of courses of lumber and a separator separating a spaced apart pair of said courses, said separator having:

a length, a height, and a width, the length being substantially longer than the height being sufficient to separate

said spaced apart pair of said courses in the stack for air circulation therebetween;

a plurality of first grooves extending transverse to the length of the separator in one direction; and

a plurality of second grooves extending transverse to both the length of the separation and the first grooves;

said plurality of first grooves and said plurality of second grooves forming a plurality of protrusions for contacting one or more pieces of lumber in said one of said courses, the protrusions having a height sufficient to permit air circulation within said grooves.

19. *An improved separator for separating lumber in a stack of a plurality of courses of lumber, said separator comprising:*

a length, a height, and a width, the length being substantially longer than the width and spanning across one or more pieces of lumber in a course, and the height being sufficient to separate a pair of courses in the stack for air circulation therebetween;

a plurality of grooves extending transverse to the length of the separator; and

a plurality of ridges with each ridge formed between a successive pair of grooves, each of said ridges having a top portion area and a corresponding bottom portion area, said top portion area defining a contact area between the separator and one or more pieces of lumber to be arranged in contact with said separator,

wherein said top portion area of each of said ridges is configured to be narrower than the corresponding bottom portion area and

wherein each of said ridges is also configured with said top portion area of said separator disposed a sufficient height above said bottom portion area to permit air circulation within each groove defined between pairs of ridges.

20. *The improved separator of claim 19, wherein the width of at least some of said ridges is substantially less than the width of at least some of said grooves.*

21. *The improved separator of claim 20, wherein said grooves and said ridges run at an angle between 20 and 90 degrees to the length of the separator.*

22. *The improved separator of claim 20, wherein said separator is generally H-shaped in transverse cross-section taken across the width of the separator.*

23. *The improved separator of claim 20, wherein each of said plurality of ridges has a substantially solid cross-section.*

24. *The improved separator of claim 20, wherein said ridges present a curved profile.*

25. *The improved separator of claim 20, wherein said ridges present a triangular profile.*

26. *The improved separator of claim 20, wherein said ridges present a trapezoidal profile.*

27. *The improved separator of claim 20, wherein said ridges are configured as protrusions, extending outwardly from said grooves.*

28. *The improved separator of claim 20, wherein said separator is manufactured from wood.*

29. *In combination, a stack made up of a plurality of courses of lumber and a separator separating a spaced apart pair of said courses, said separator comprising:*

a length, a height, and a width, the length being substantially longer than the width and spanning across one or more pieces of lumber in one of said courses, the height being sufficient to separate said spaced apart pair of said courses in the stack for air circulation therebetween;

a plurality of grooves extending transverse to the length of the separator; and

a plurality of ridges with each ridge formed between a successive pair of grooves, each of said ridges having a top portion area and a corresponding bottom portion area, said top portion area defining a contact area between the separator and one or more pieces of lumber to be arranged in contact with said separator, wherein said top portion area of each of said ridges is configured to be narrower than the corresponding bottom portion area and

wherein each of said ridges is also configured with said top portion area of said separator disposed a sufficient height above said bottom portion area to permit air circulation within each groove defined between pairs of ridges.

30. *The combination of claim 29, wherein said grooves and said ridges run at an angle between 20 and 90 degrees to the length of the separator.*

31. *The combination of claim 30, wherein said separator is generally H-shaped in transverse cross-section taken across the width of the separator.*

32. *The combination of claim 29, wherein each of said plurality of ridges has a substantially solid cross-section.*

33. *The combination of claim 29, wherein said ridges present a curved profile.*

34. *The combination of claim 29, wherein said ridges present a triangular profile.*

35. *The combination of claim 29, wherein said ridges present a trapezoid profile.*

36. *The combination of claim 29, wherein said ridges are configured as protrusions, extending outwardly from said grooves.*

37. *The combination of claim 29, wherein said separator is manufactured from wood.*

* * * * *