



US00RE38099E

(19) **United States**
(12) **Reissued Patent**
Furomoto et al.

(10) **Patent Number: US RE38,099 E**
(45) **Date of Reissued Patent: Apr. 29, 2003**

(54) **SPINNING REEL HAVING BALANCER**

3,797,774 A 3/1974 Dumbauld

(List continued on next page.)

(75) Inventors: **Yoshiyuki Furomoto**, Osaka (JP);
Hideo Noda, Osaka (JP); **Noboru Sakaguchi**, Osaka (JP); **Osamu Yoshikawa**, Osaka (JP)

FOREIGN PATENT DOCUMENTS

(73) Assignee: **Shimano Inc.**, Sakai (JP)

(*) Notice: This patent issued on a continued prosecution application filed under 37 CFR 1.53(d), and is subject to the twenty year patent term provisions of 35 U.S.C. 154(a)(2).

FR	1113782	4/1956
FR	1091707	6/1956
FR	1213235	3/1960
FR	1217679	5/1960
FR	1261980	4/1961
FR	1506359	12/1967
FR	2195397	3/1974
FR	2393530	1/1979
FR	2615358	11/1988
GB	882777	11/1961
GB	1314892	4/1973
GB	1320795	6/1973
GB	1320796	6/1973

(21) Appl. No.: **08/780,333**

(22) Filed: **Jan. 7, 1997**

(List continued on next page.)

Related U.S. Patent Documents

Reissue of:

(64) Patent No.: **5,379,957**
Issued: **Jan. 10, 1995**
Appl. No.: **07/881,790**
Filed: **May 12, 1992**

OTHER PUBLICATIONS

Photographic exhibit—10 packs of photographs of prior known spinning reels; no date avail.*
Videotape exhibit—videos (2) of known spinning reels—no date available.*
J.P. Den Hartog, *Mechanical Vibrations*, pp. 292–312 (McGraw–Hill Book Company, Inc. New York, NY 1947).

(List continued on next page.)

(30) Foreign Application Priority Data

May 14, 1991	(JP)	3-033214
Jul. 25, 1991	(JP)	3-184988
Jul. 25, 1991	(JP)	3-184989
Nov. 14, 1991	(JP)	3-298634

Primary Examiner—Katherine A. Matecki
(74) *Attorney, Agent, or Firm*—Jeffer, Mangels, Butler & Marmaro LLP

(51) **Int. Cl.⁷** **A01K 89/01**

(52) **U.S. Cl.** **242/230**

(58) **Field of Search** 242/230, 231,
242/232, 233

(57) ABSTRACT

A spinning reel has a reel body and a [color] rotor attached to the reel body and rotatable about a longitudinal axis for retrieving a fishing line. The spinning reel also has a [balancer attached to the rotor for restricting an imbalance amount of rotation of the rotor substantially within 200 g-mm] bail and a balancer attached to the rotor at the base end portion of the rotor for facilitating counterbalancing of the bail in a line retrieving position. The balancer and the bail in its line retrieving position are located on a first side of a reference plane defined through the longitudinal axis.

(56) References Cited

U.S. PATENT DOCUMENTS

2,713,463 A	7/1955	Sarah
2,966,314 A	12/1960	Mombur
3,670,985 A	6/1972	Morishita
3,743,207 A *	7/1973	McMickle
3,788,570 A	1/1974	Yamazaki et al.

32 Claims, 17 Drawing Sheets

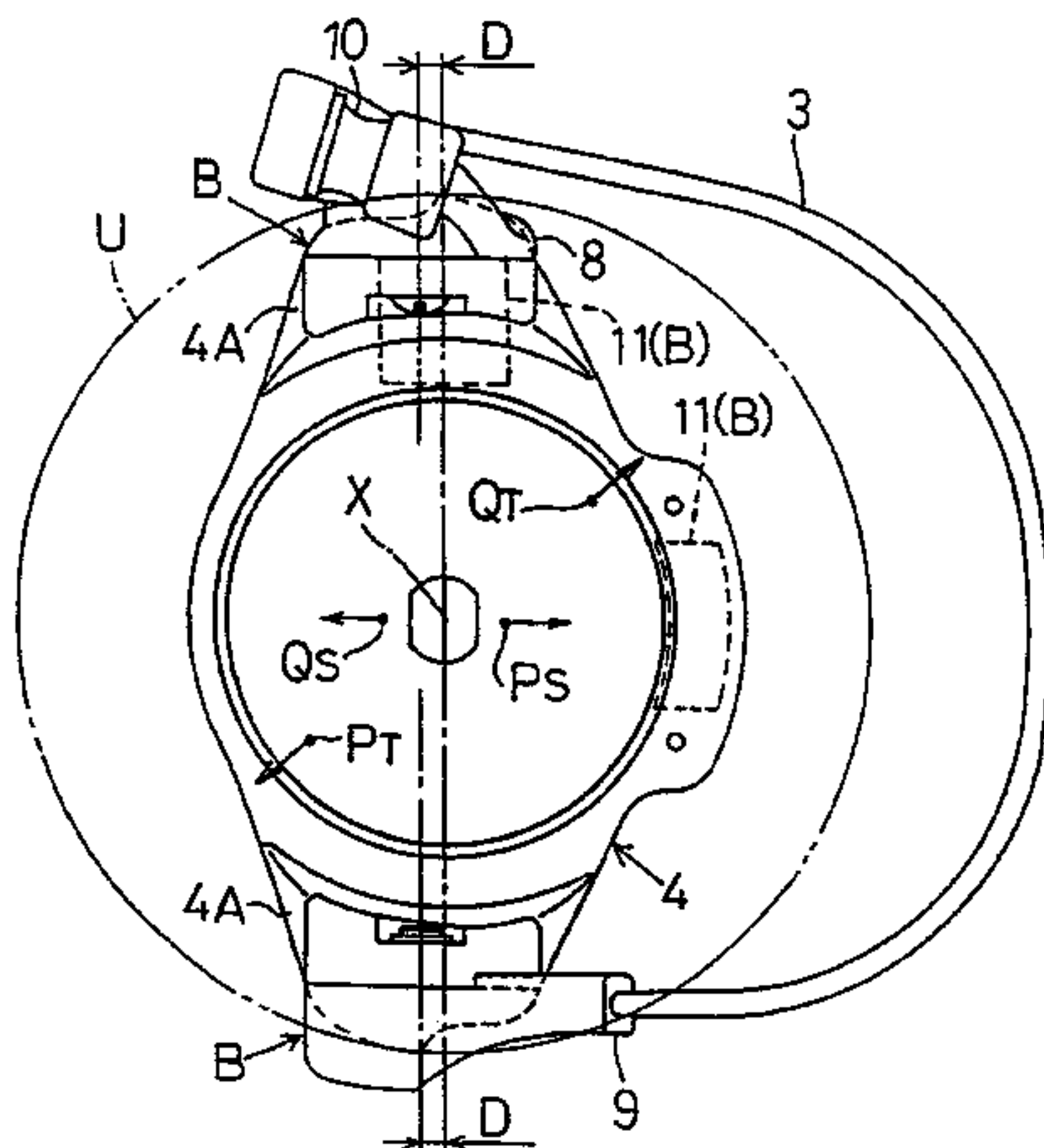

U.S. PATENT DOCUMENTS

3,967,791	A	7/1976	Morishita	
4,005,832	A	2/1977	Yamazaki	
4,014,422	A	3/1977	Morishita 192/67 R
D247,442	S	3/1978	Hiraishi et al. D22/25
4,095,756	A	* 6/1978	Morishita	
3,979,082	A	4/1979	Morishita	
4,147,313	A	4/1979	Sazaki	
4,162,048	A	7/1979	Sazaki	
4,202,508	A	5/1980	Ishida et al.	
4,389,027	A	6/1983	Sazaki et al.	
D278,359	S	4/1985	Sugimoto D22/25
D280,230	S	8/1985	Matsui D22/25
4,575,024	A	3/1986	Kaneko	
D290,732	S	7/1987	Yamaguchi D22/137
D290,986	S	7/1987	Yamaguchi D22/137
4,702,432	A	10/1987	Kaneko et al.	
4,705,228	A	11/1987	Manuyama et al.	
4,733,830	A	* 3/1988	Hollander	
4,763,856	A	8/1988	Kaneko	
4,848,695	A	7/1989	Kaneko 242/232
4,858,845	A	8/1989	Kaneko 242/285
4,874,144	A	* 10/1989	Murakami 242/230
4,884,761	A	* 12/1989	Kuntze	
4,923,140	A	5/1990	Yamaguchi et al. 242/230
4,969,613	A	11/1990	Kaneko 242/231
D314,808	S	2/1991	Yoshikawa D22/141
5,096,137	A	3/1992	Carlsson et al. 242/233
5,149,007	A	9/1992	Saito 242/246
5,207,396	A	5/1993	Furomoto 242/321
5,211,355	A	5/1993	Furomoto 242/310
5,221,057	A	6/1993	Yoshikawa 242/247
5,228,639	A	7/1993	Sato 242/262
5,246,186	A	9/1993	Sugawara 242/232
5,289,990	A	3/1994	Kawabe 242/233
5,295,640	A	3/1994	Kawabe 242/248
5,316,239	A	5/1994	Sugawara 242/241
5,318,247	A	6/1994	Sugawara 242/319
5,328,138	A	7/1994	Sakaguchi 242/300
5,356,091	A	10/1994	Sugawara 242/319

FOREIGN PATENT DOCUMENTS

JP	36-11285	5/1961
JP	39-16088	8/1964
JP	51-126295	10/1976
JP	52-55892	4/1977
JP	52-80887	* 6/1977
JP	53-14636	4/1978
JP	53-33033	8/1979
JP	56-37879	4/1981
JP	56-109532	8/1981
JP	58-121565	8/1983
JP	62-80568	4/1987
JP	724787	2/1988
JP	758572	3/1989
JP	1-105464	3/1989
JP	807623	1/1991
JP	3-216133	9/1991

OTHER PUBLICATIONS

International Standart 1940/1, pp. 1-13 (Switzerland 1986).
 International Standard 8821, pp. 1-12 (Switzerland 1989).
 Daiwa Fishing Tackle Catalog (1990) pp. 40-41.
 Daiwa Fishing Tackle Catalog (1991) pp. 88-89.
 Shimano NFT Fishing Tackle Catalogue (1988) (page unknown).

Daiwa Fishing Tackle Catalog (1984) pp. 36+.
 Ryobi Fishing Tackle Catalog (1987) pp. 14-15.
 Ryobi Catalog (1988) pp. 13-23.
 Ryobi Powerful Series Catalog (1978) pp. 9-10.
 Ryobi Fishing Tackle Catalog (1980) pp. 2-15.
 Harmon Henkin, The Complete Fisherman's Catalog (1977) pp. 148-149.
 Coarse Fishing Today, Dec. 1989/Jan. 1990 (page unknown).
 Coarse Fishing Today, Apr./May 1986, p. 32.
 Coarse Fisherman, May 1987, p. 41.
 Coarse Fisherman, Feb. 1990, p. 60.
 Ryobi Catalog (1978) pp. 5-6, 9-10.
 7007657, German abstract (Mar. 3, 1970).
 Daiwa Catalog, pp. 2-7 (1989).
 Ryobi Fishing Tackle Catalog (1980) pp. 5-10.
 Jarvis Walker Catalog (1977) (page unknown).
 Ryobi Catalog—Powerful Series (1978) (pages unknown).
 Ryobi Fishing Tackle Catalog (1979) (pages unknown).
 Sears Catalog (1972) pp. 2+.
 Mitchell Catalog (date and pages unknown).
 Daiwa Catalog (1988) (page unknown).
 Daiwa Buying Guide (1991) (page unknown).
 Ryobi Catalog—AX Series (date unknown) pp. 3-4.
 Daiwa Catalog (1966) p. 9.
 Penn Reels Fresh and Salt Water Reel Catalog (not prior to 1975) p. 5.
 Ryobi Price List (1977).
 Ryobi Fishing Tackle Price List (1977).
 Ryobi Parts Catalog (1987) pp. A-1 to B-118.
 Ryobi Catalog (1988) p. 36.
 Ryobi Enjoy Fishing Catalog (1975) (pages unknown).
 Ryobi Catalog (1976) (pages unknown).
 Ryobi Fishing Tackle Catalog (1978) (pages unknown).
 Ryobi brochure (1977) (pages unknown).
 Jarvis Walker brochure (1977) (pages unknown).
 Ryobi Catalog (1978) (pages unknown).
 Shimano Fishing Tackle Catalog (1980) (pages unknown).
 Drawing of Daiwa Tournament EX-750 reel (date unknown).

* cited by examiner

FIG. 1

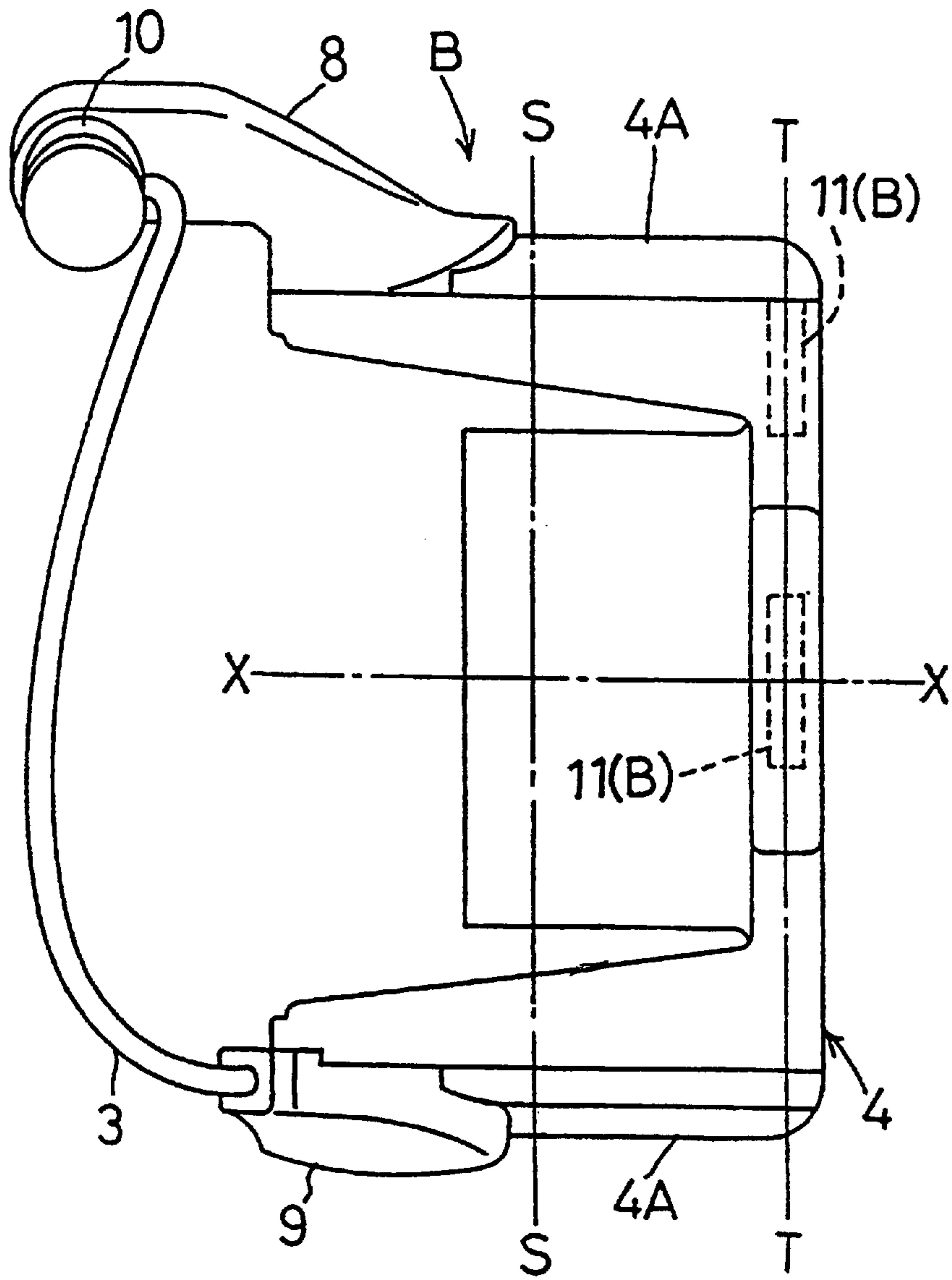

FIG. 2

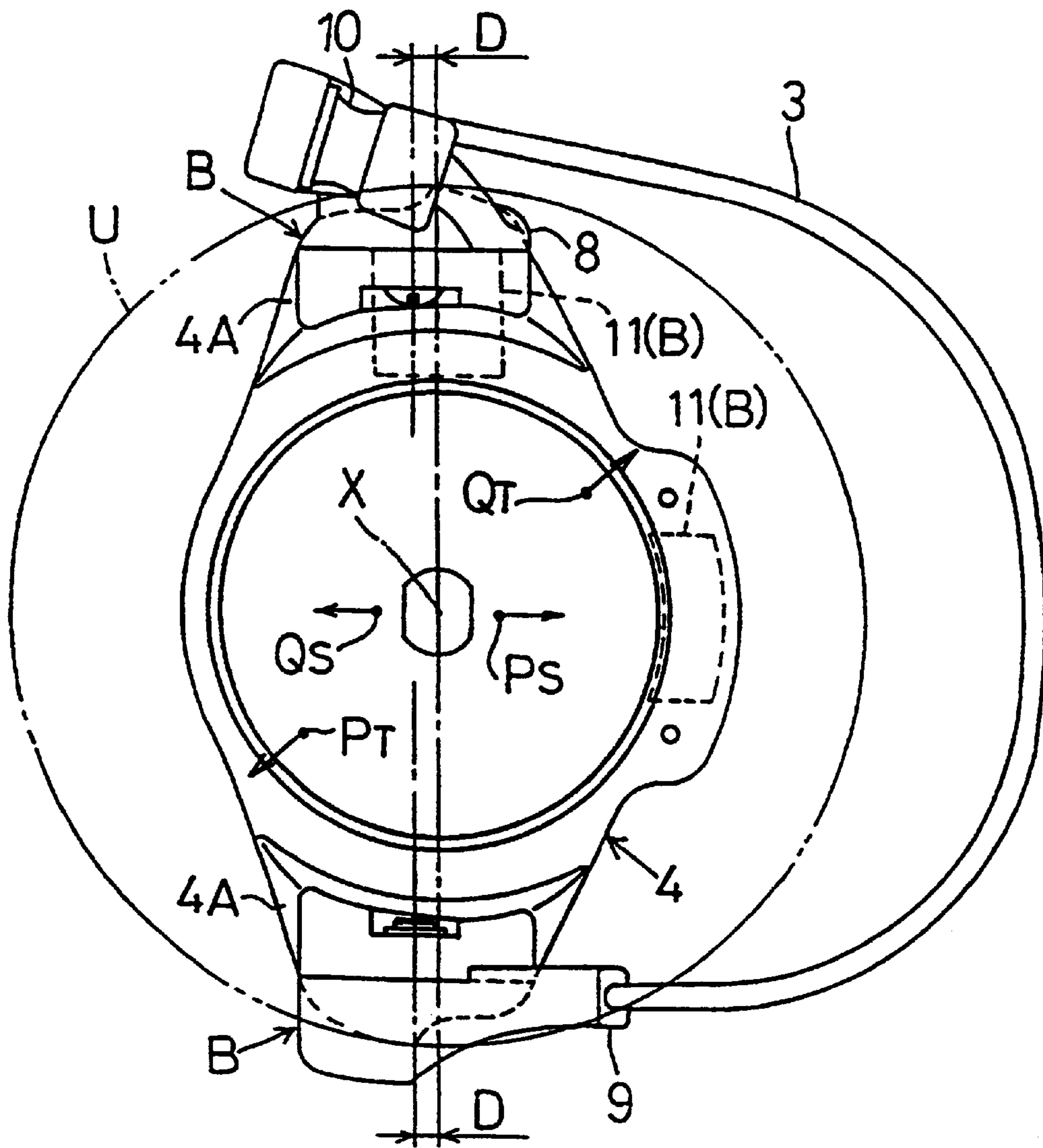

FIG. 3

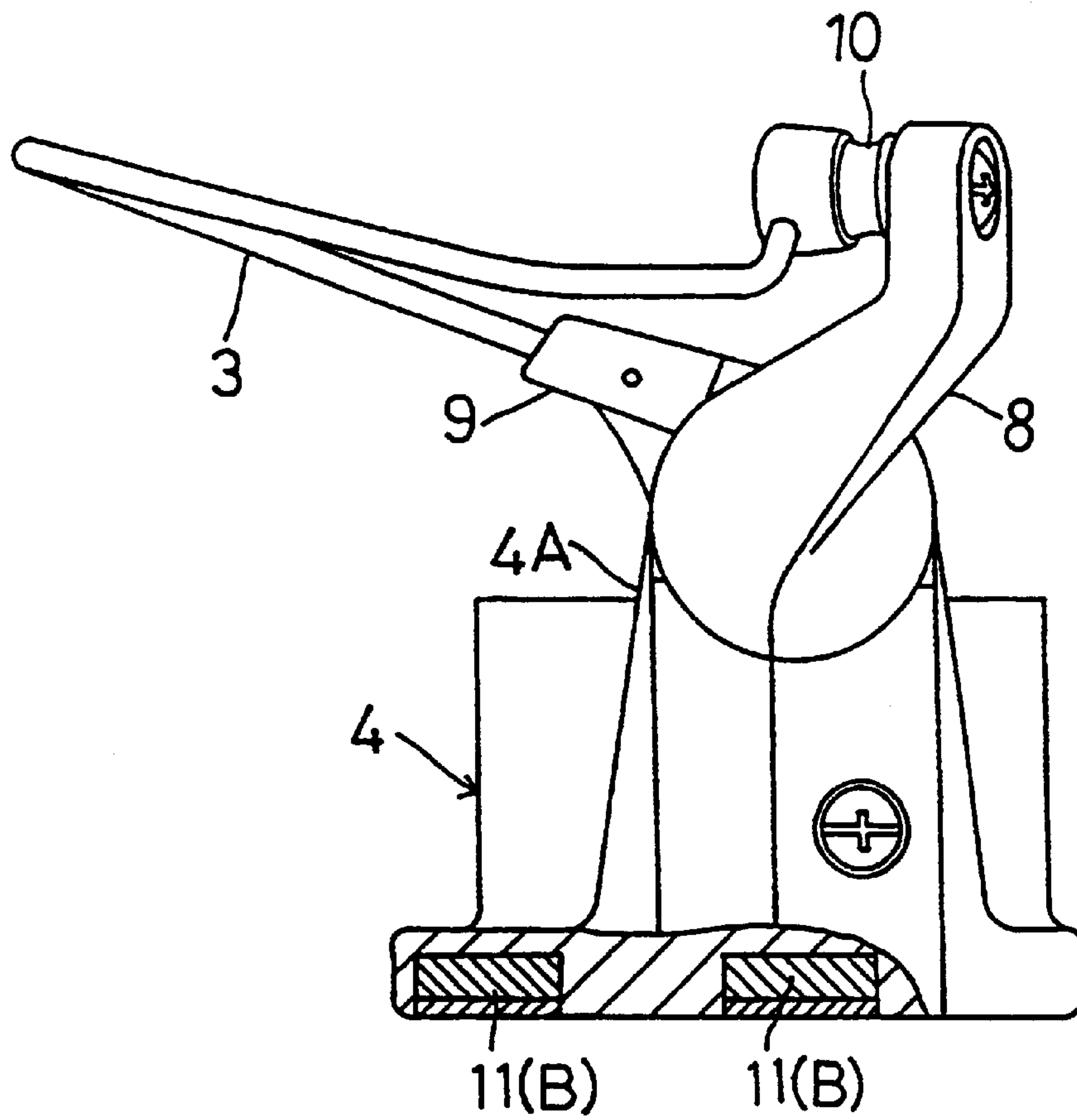

FIG. 4

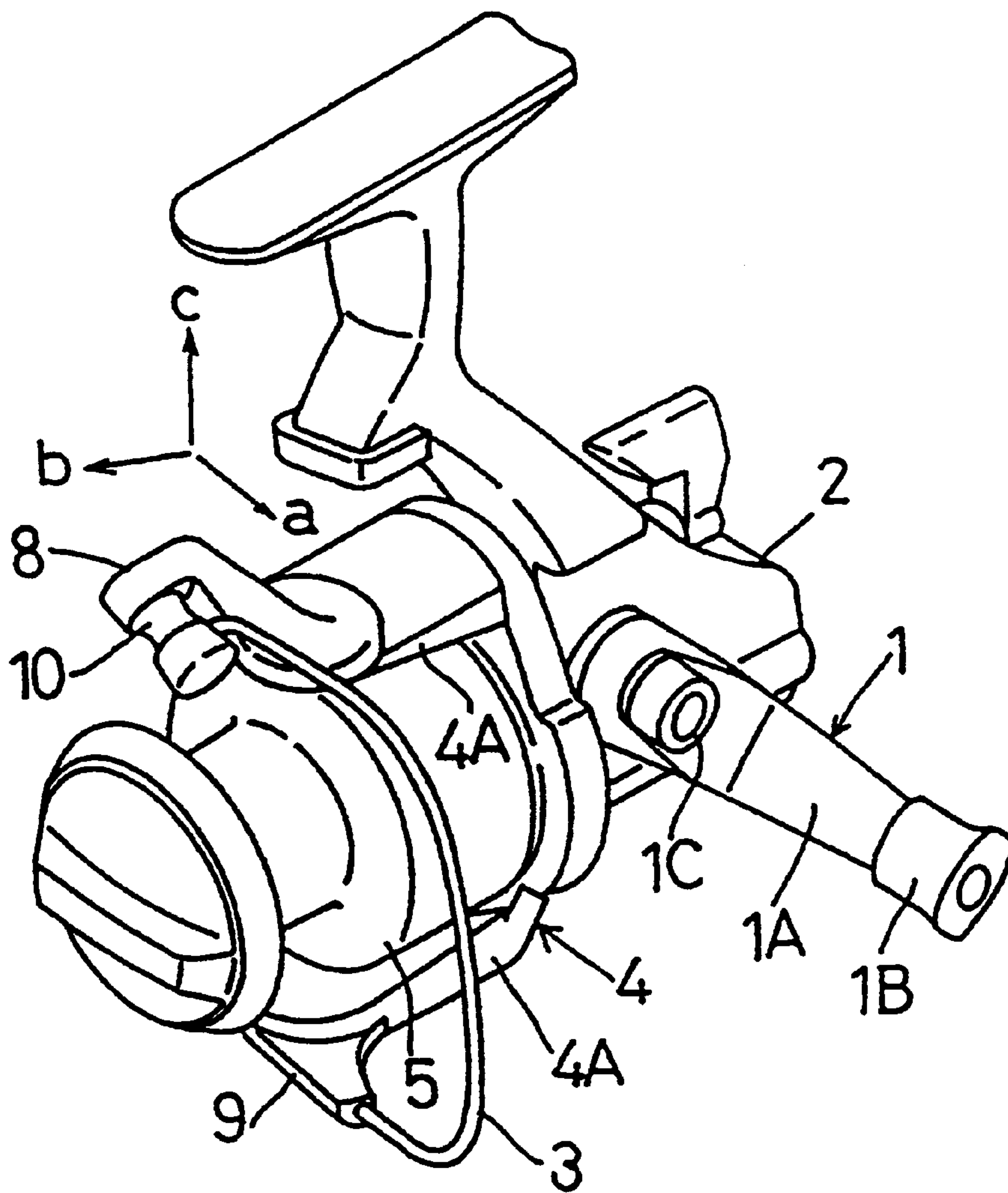

FIG. 5

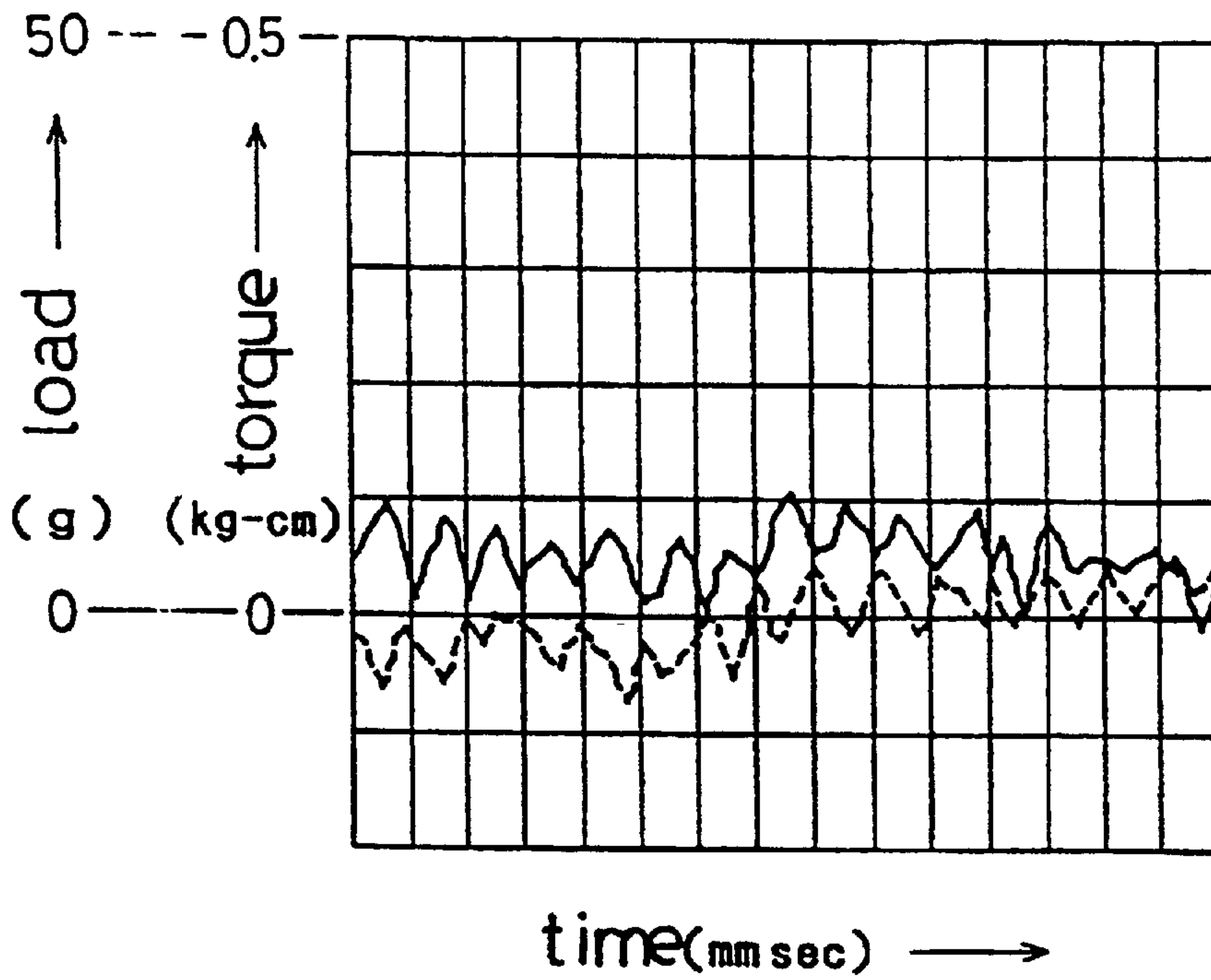

FIG. 6

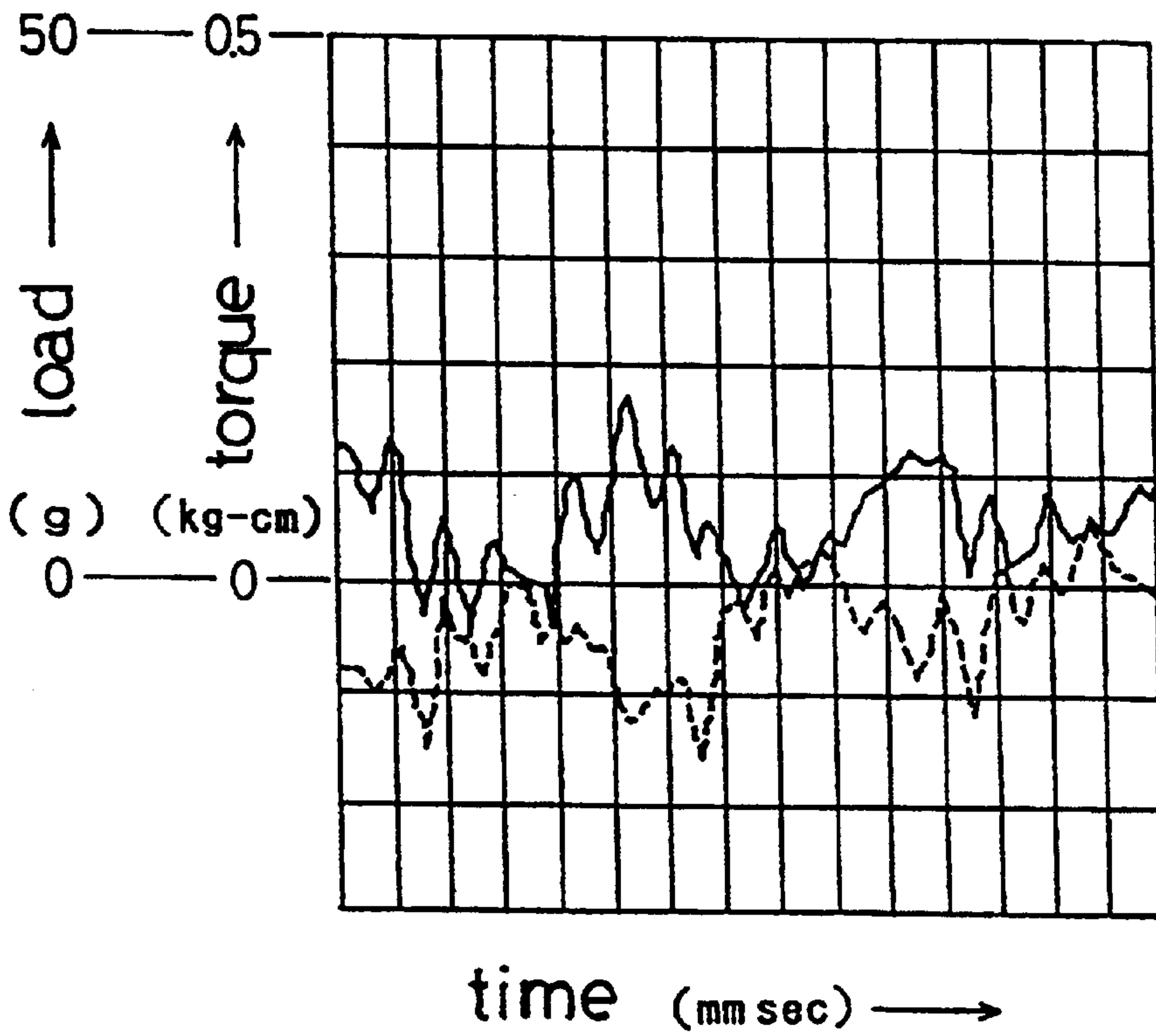

FIG. 7

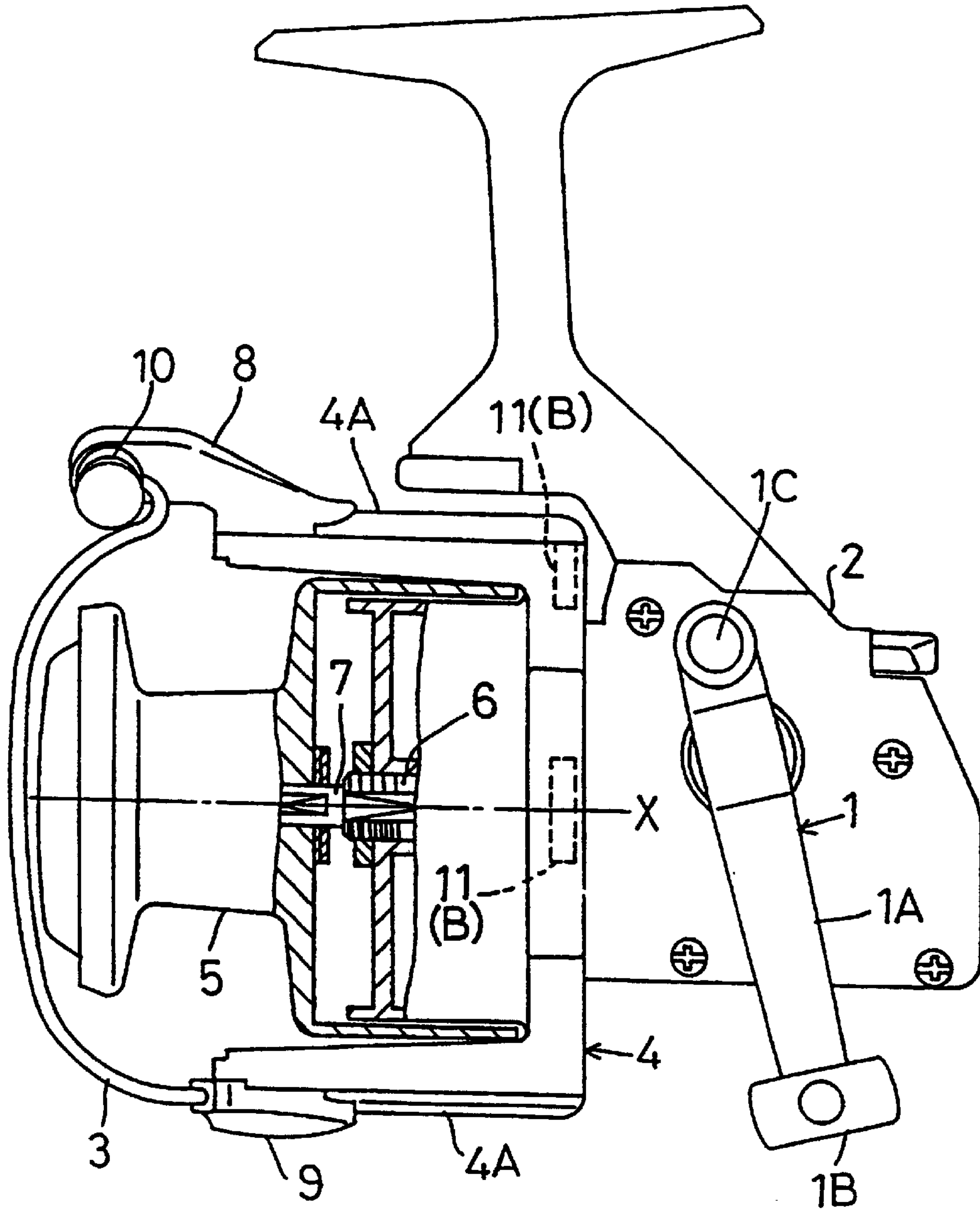

FIG. 8

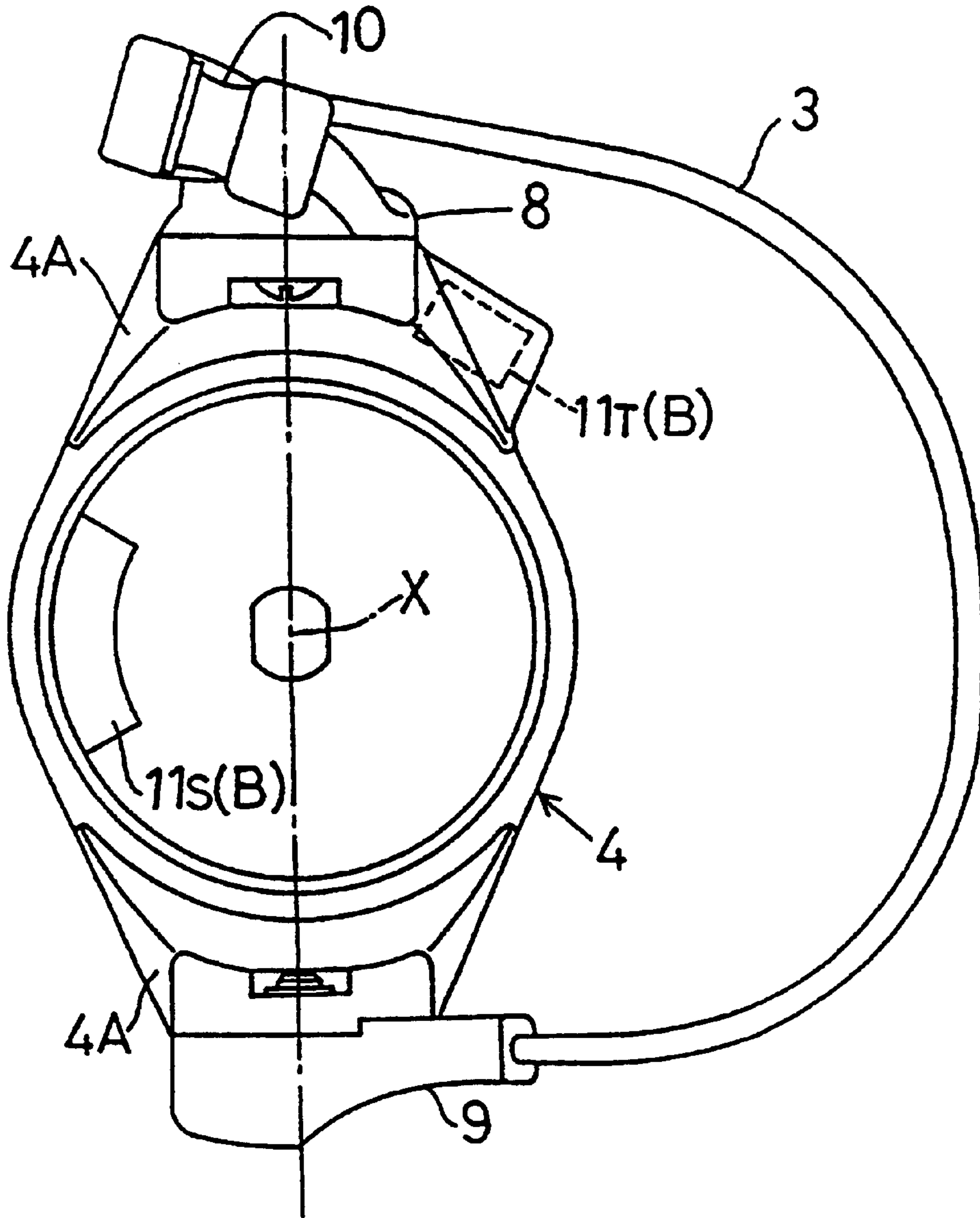

FIG. 9

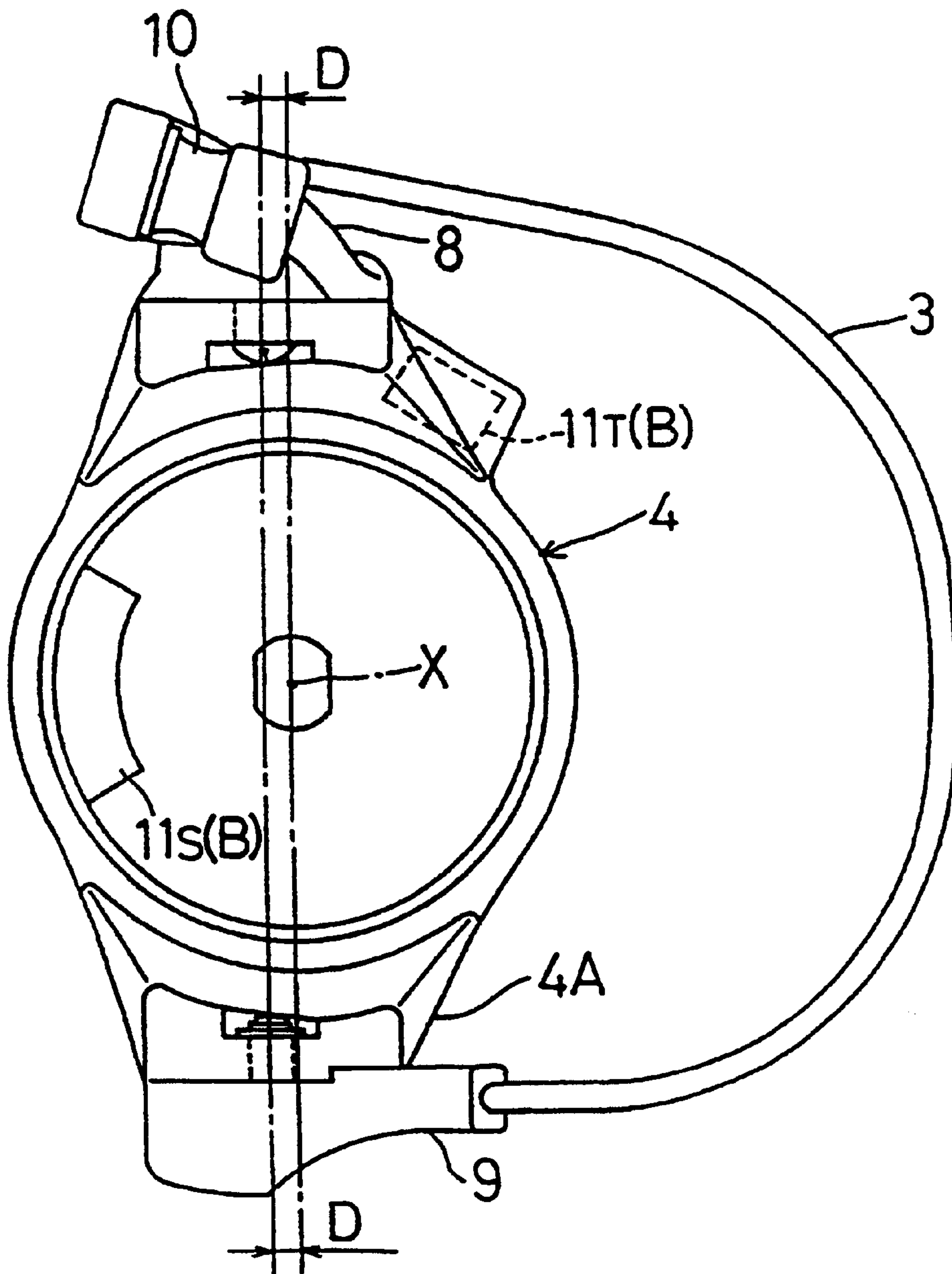

FIG. 10

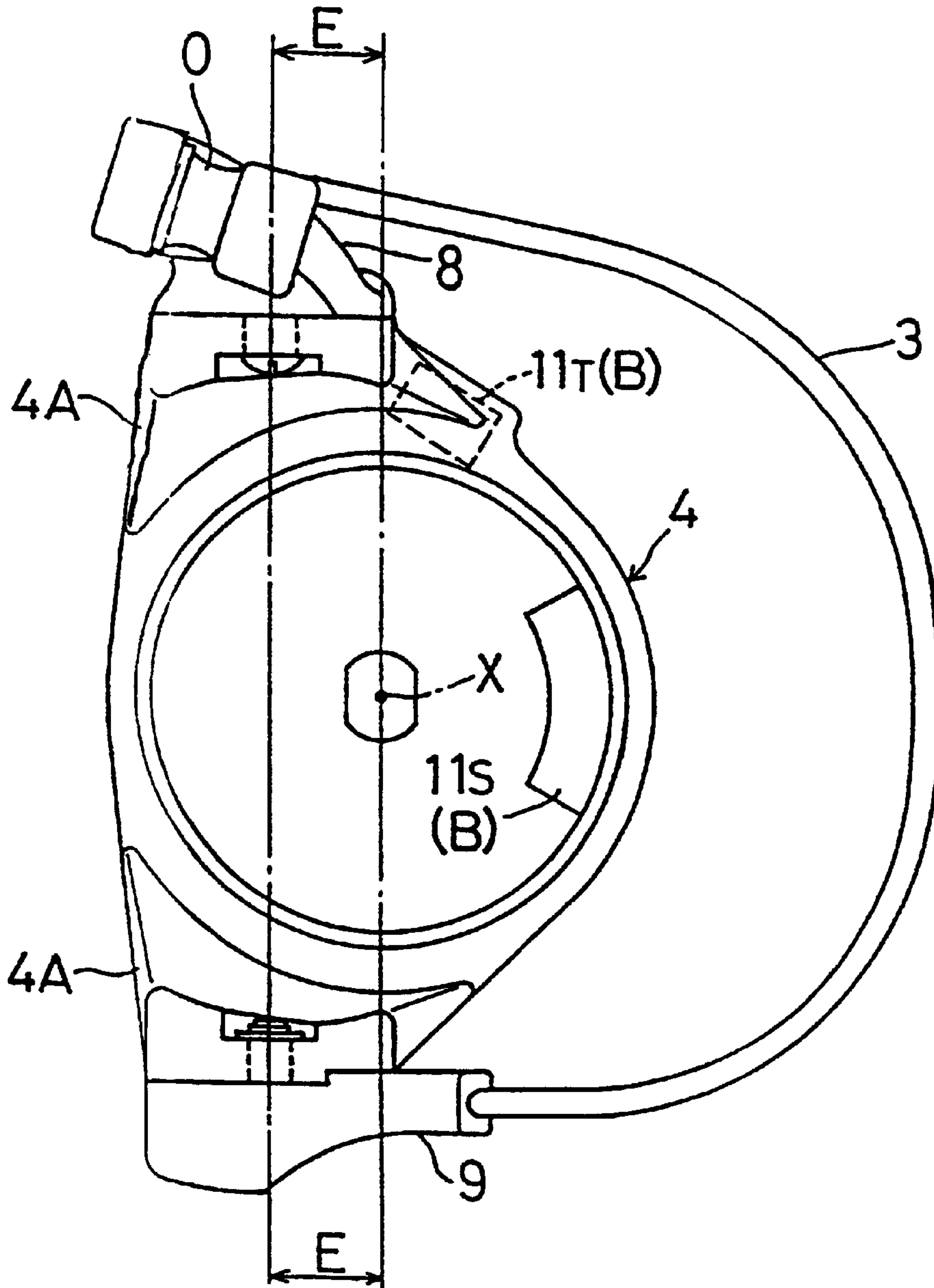

FIG. 11

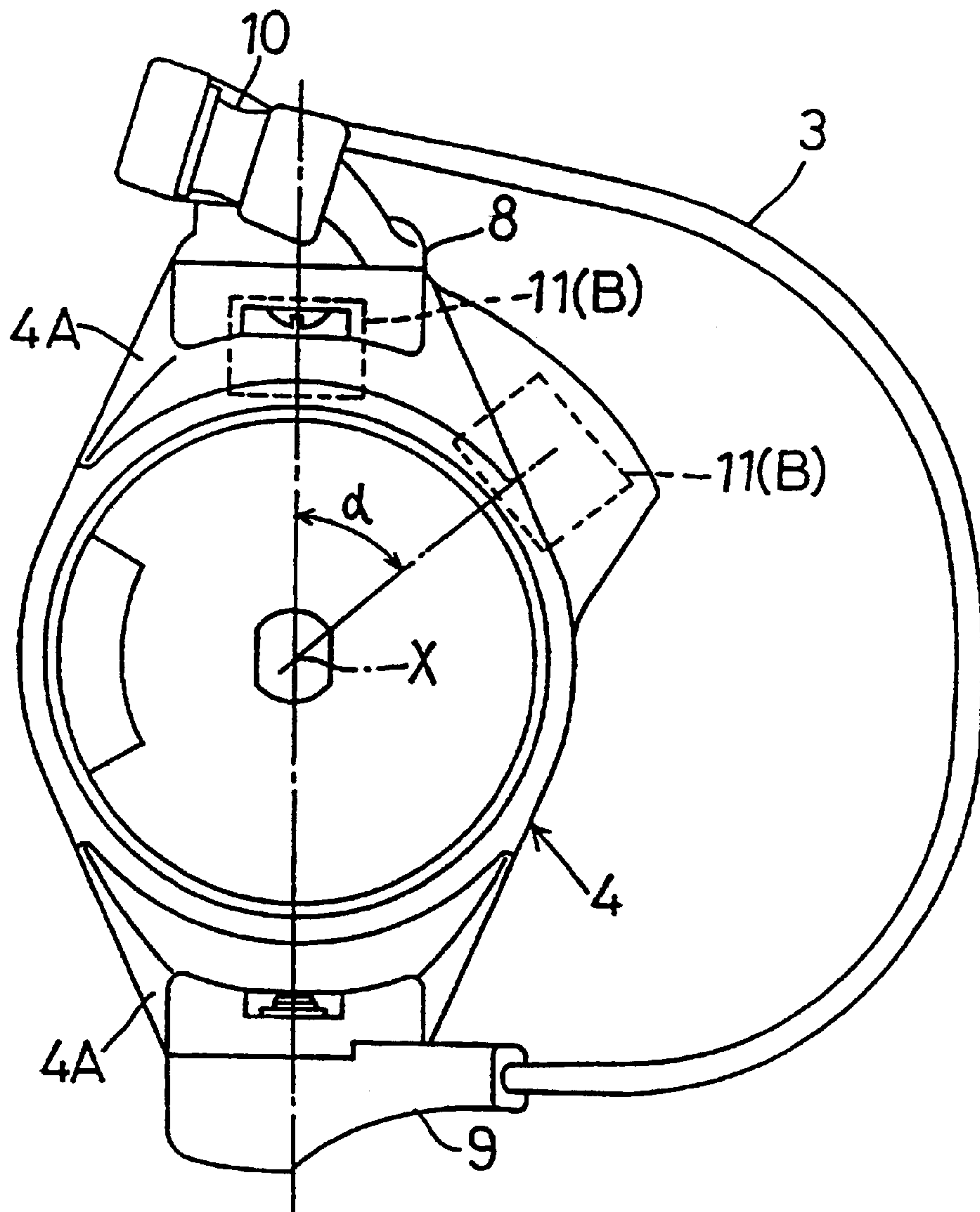

FIG. 12

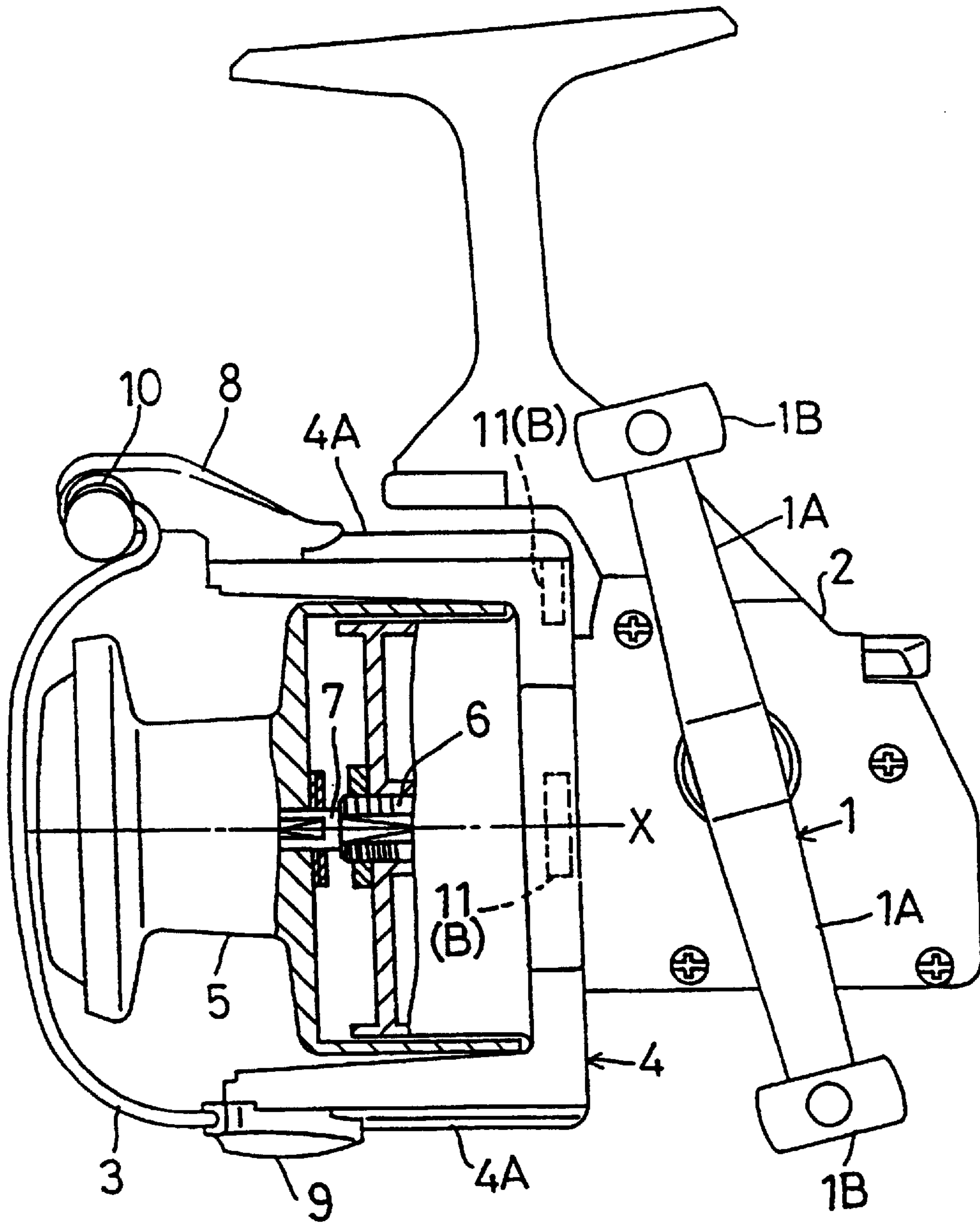

FIG. 13

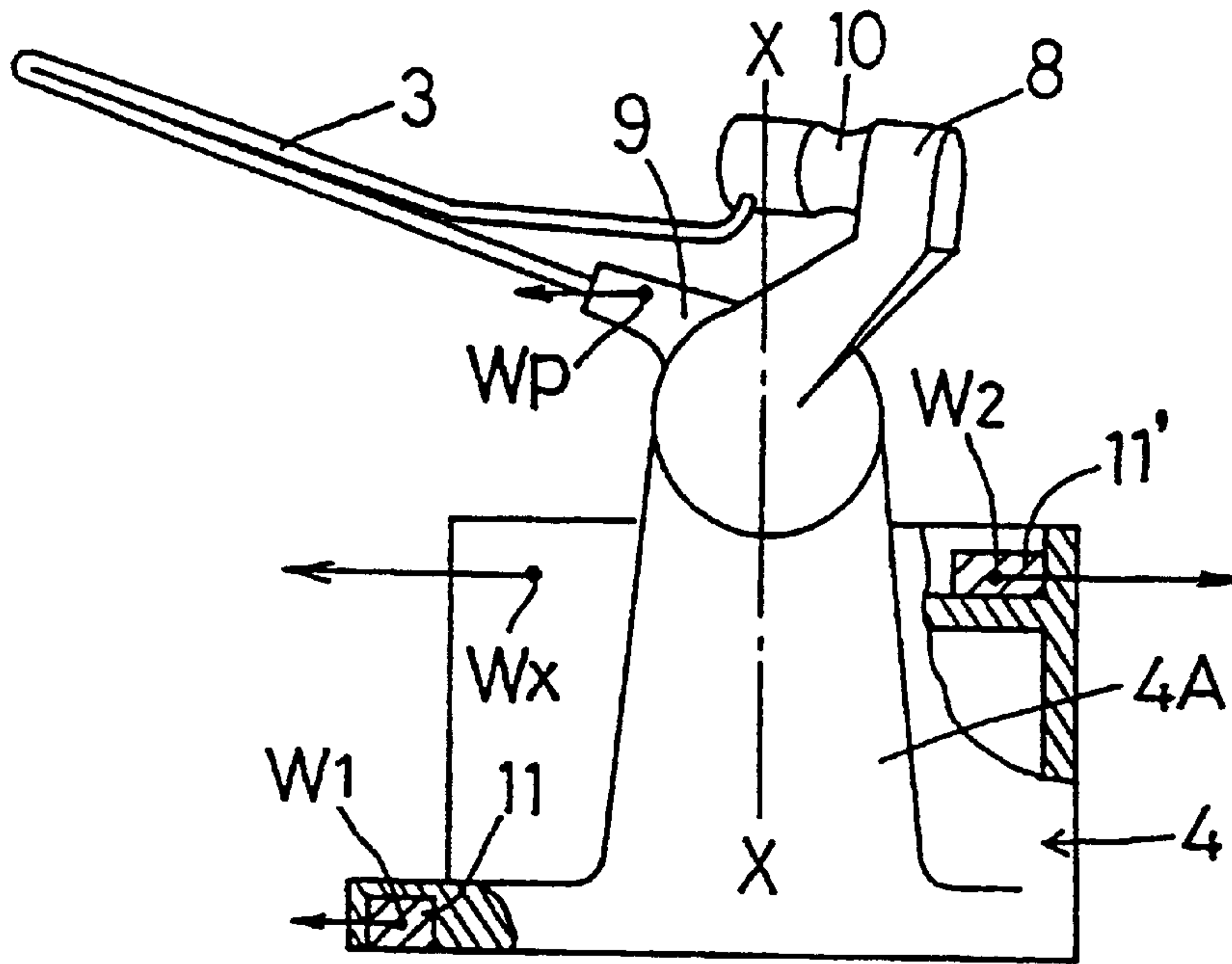

FIG. 14

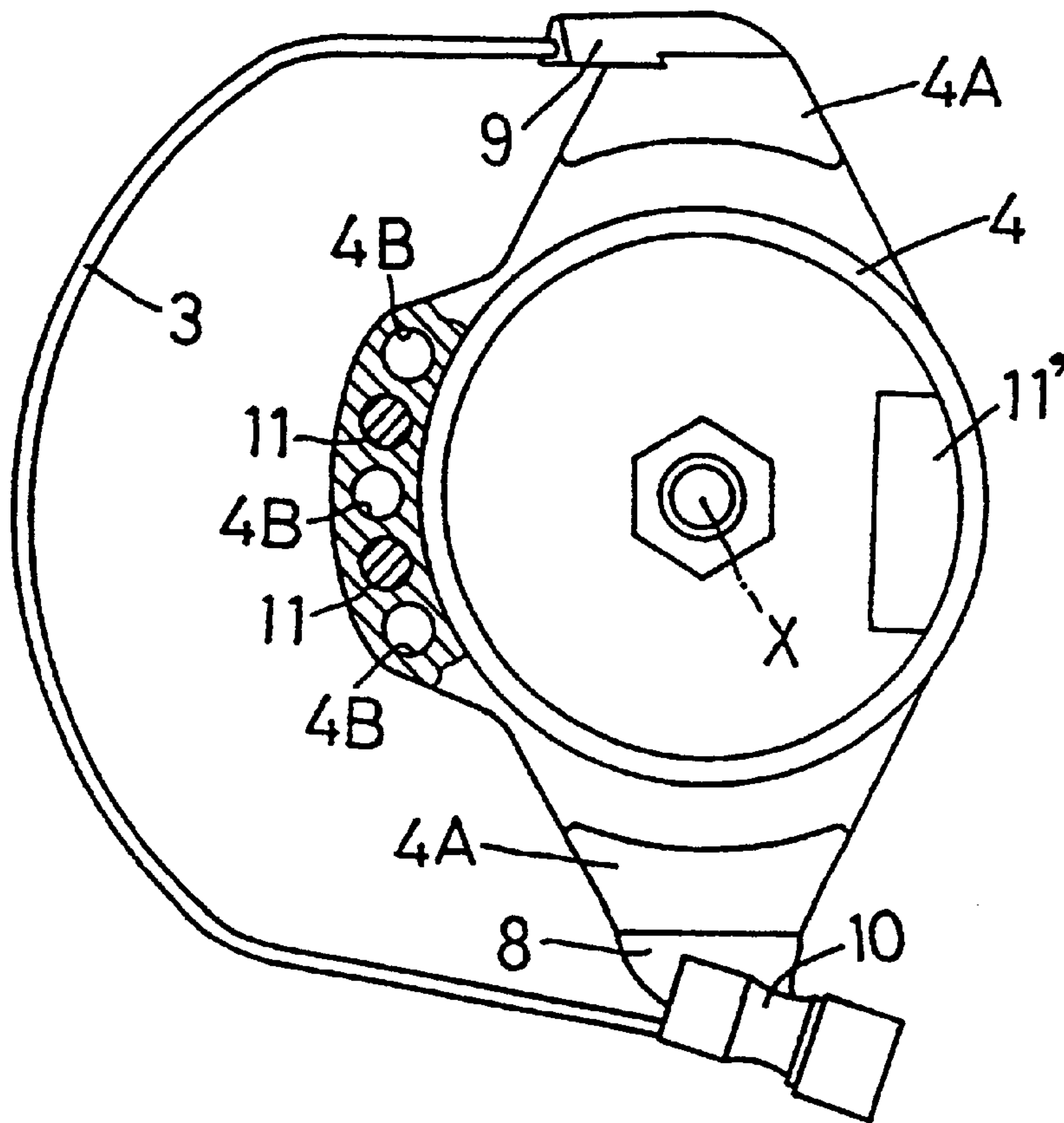

FIG. 16

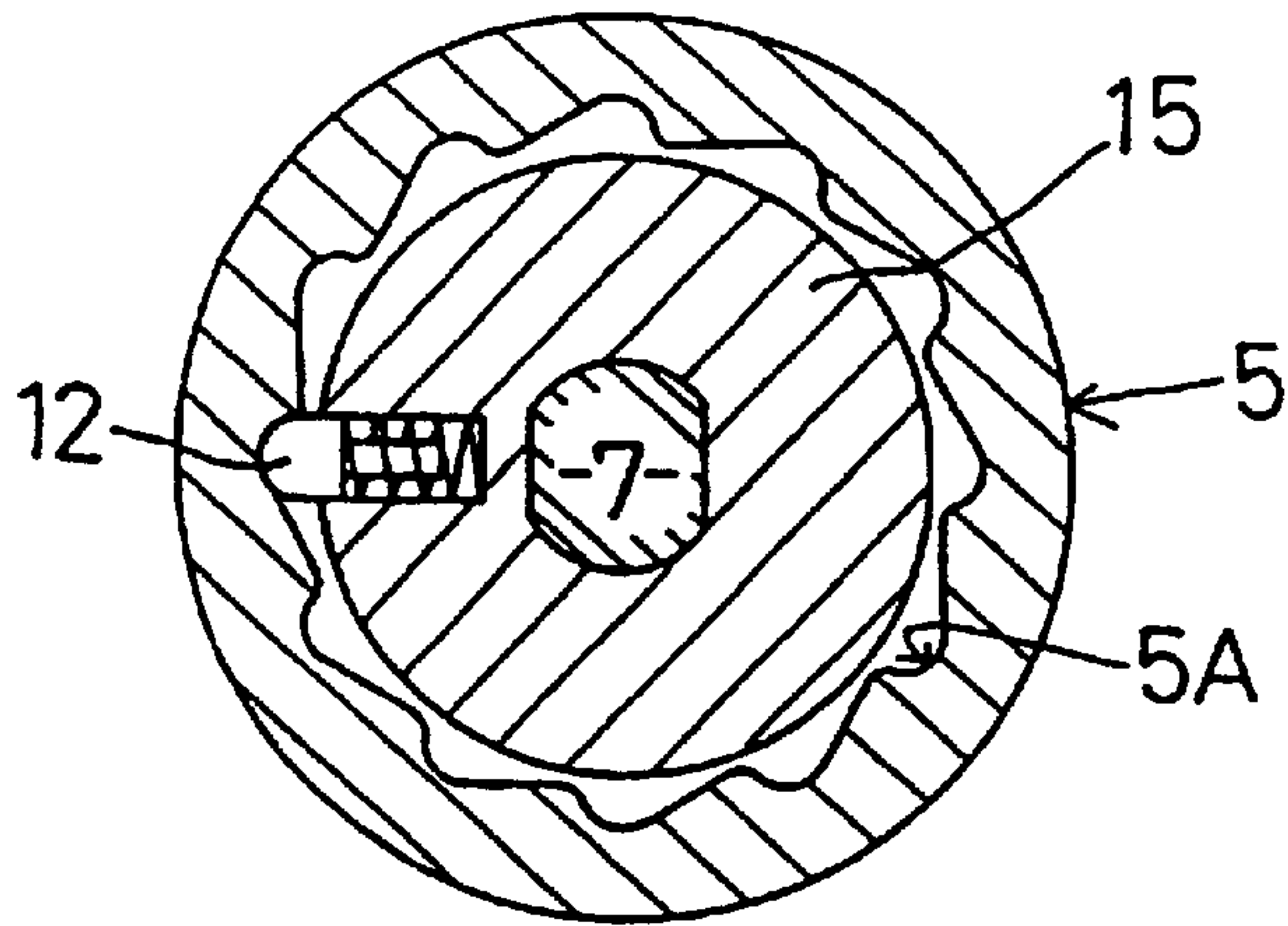

FIG. 17

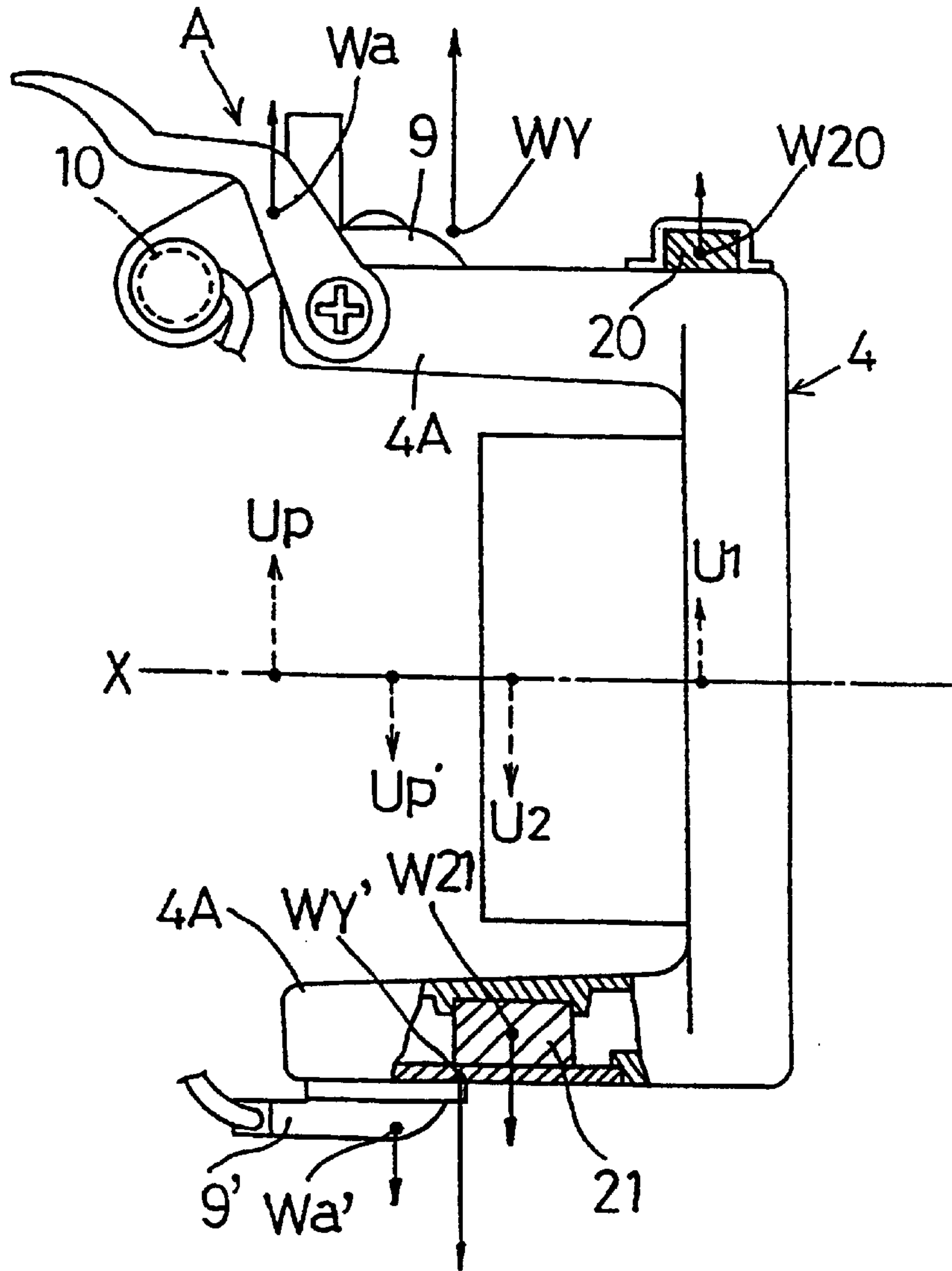

FIG.18

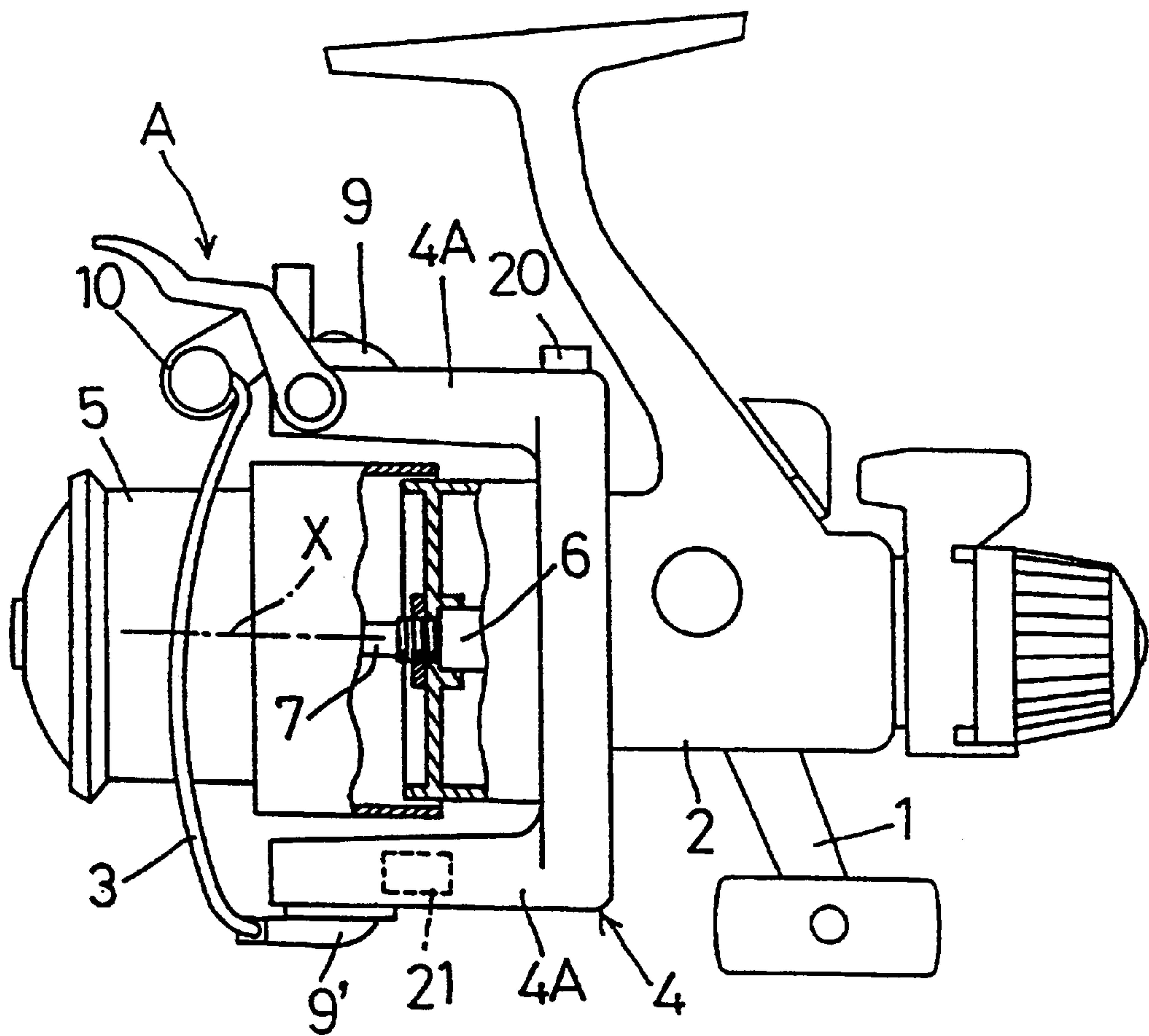

FIG. 19

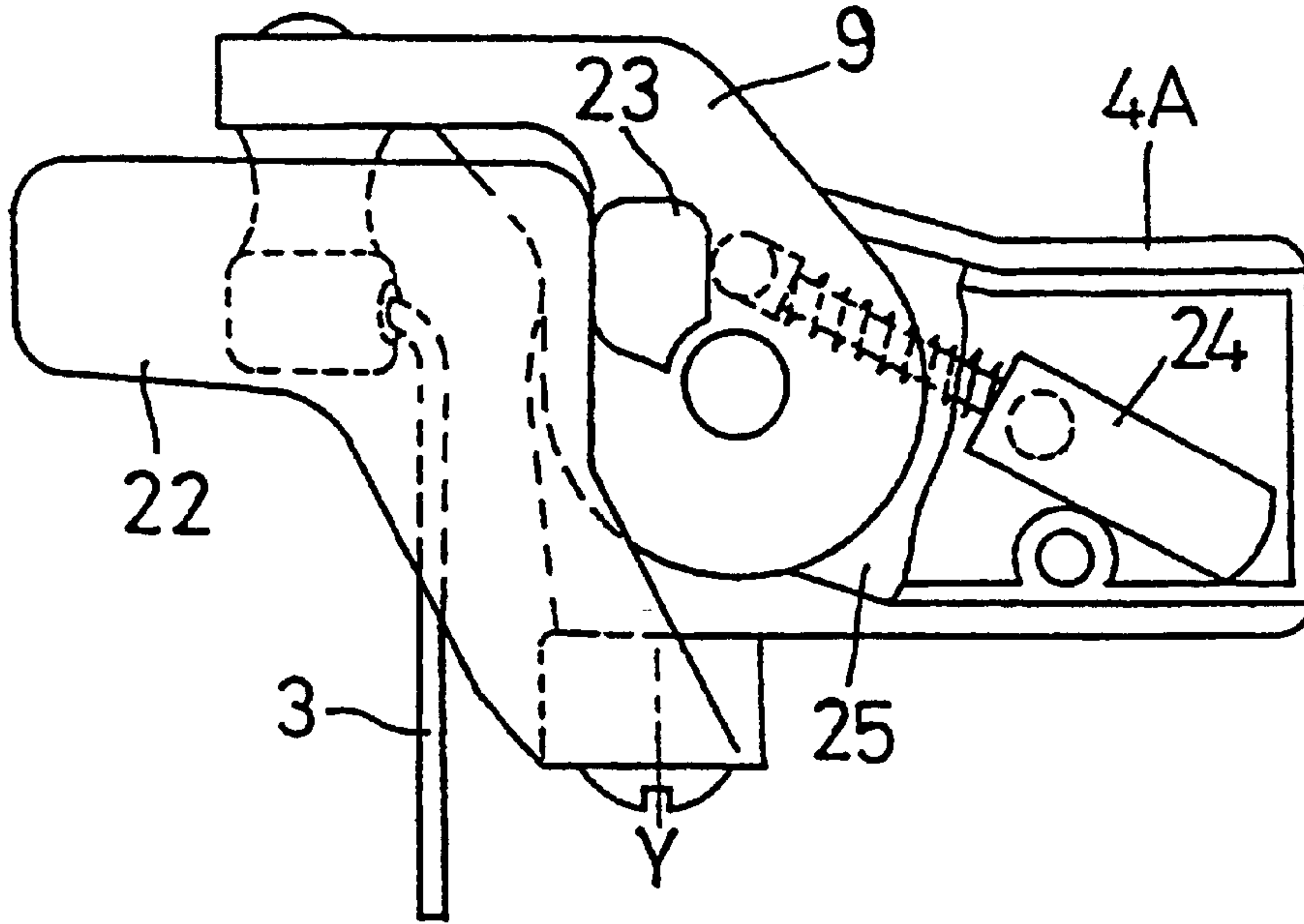

FIG. 20

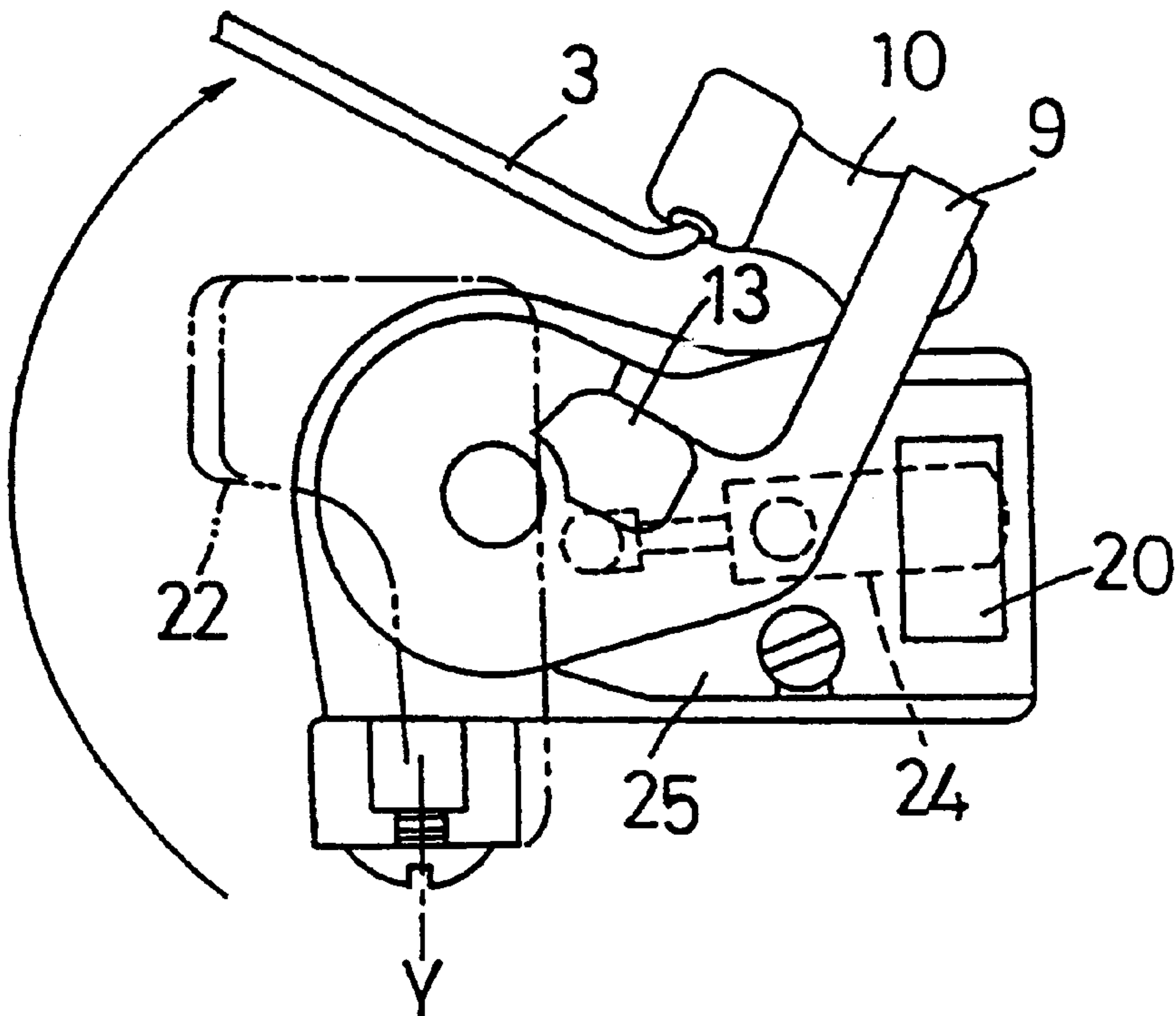

FIG. 21

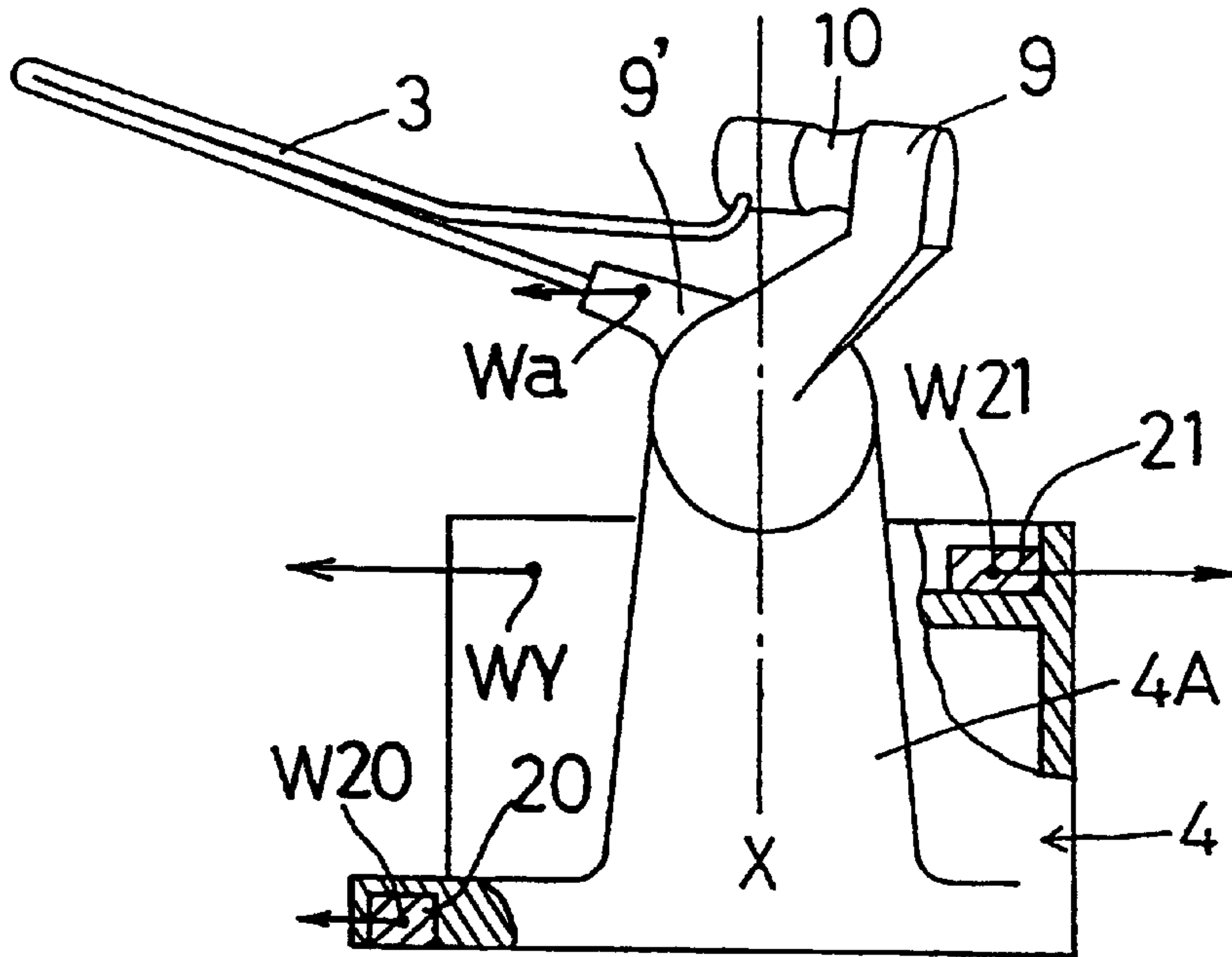
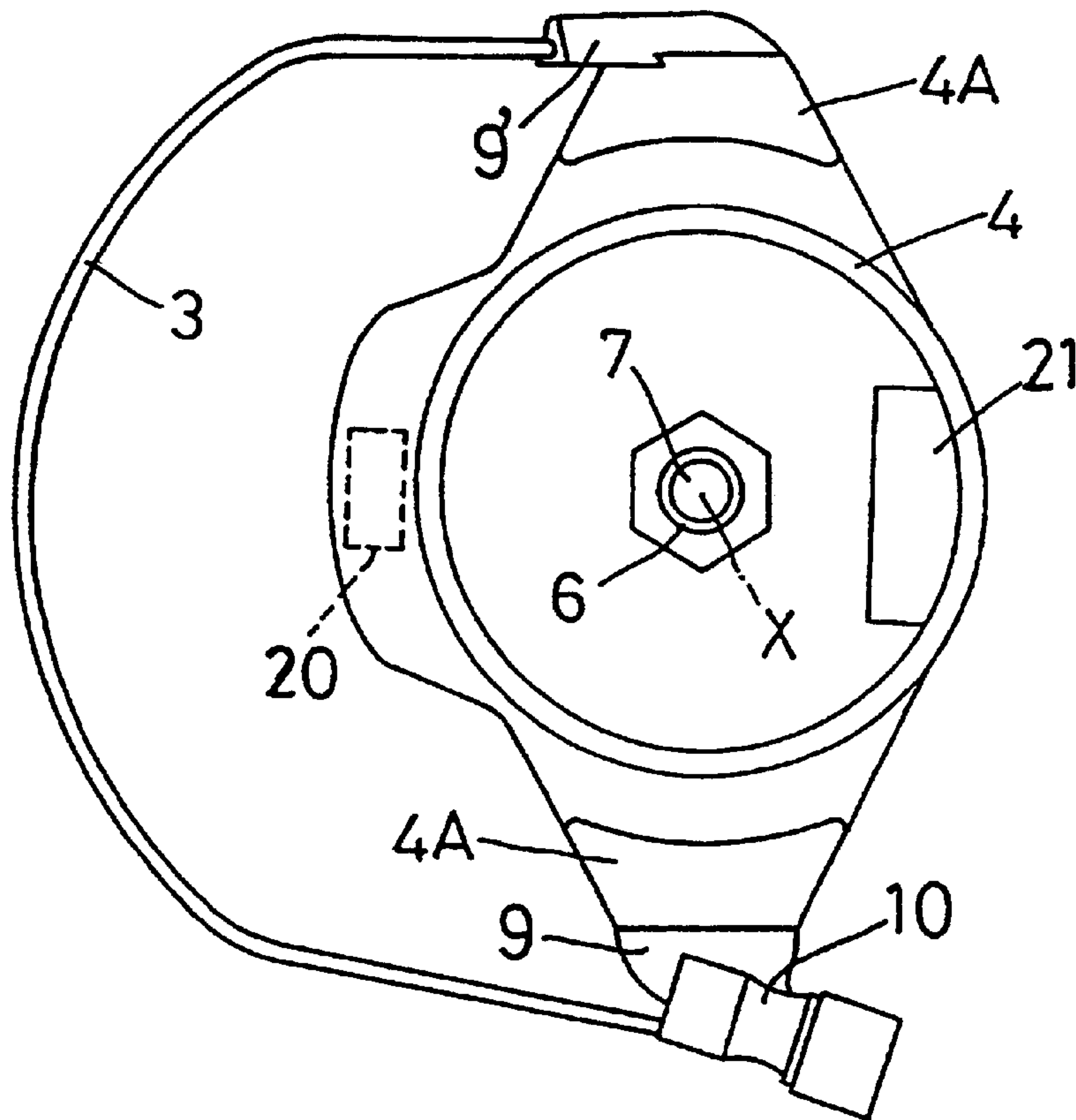

FIG. 22



SPINNING REEL HAVING BALANCER

Matter enclosed in heavy brackets [] appears in the original patent but forms no part of this reissue specification; matter printed in italics indicates the additions made by reissue.

BACKGROUND OF THE INVENTION

1. Field of the Invention

The present invention relates to a spinning reel having a balancing means for restricting rotational imbalance of a rotor.

2. Description of the Related Art

There is known a spinning reel having a balancer weight attached to a rotor as the above-mentioned balancing means (e.g. Japanese laid-open utility model gazette No. 52-80887).

However, with the above described balancer weight it is difficult to achieve complete solution to the rotational imbalance. On the other hand, has been practically impossible to modify a configuration of the rotor or an arrangement of components thereof for the sole purpose of improvement in the balance.

With this type of balancer, the farther the balancer is disposed relative to the rotational axis, the greater a value of the moment becomes. Therefore, in often times, a balancer of a relatively small weight will suffice for the purpose. However, in the case of the conventional construction where the balancer is attached to a cylindrical portion of the rotor, since this cylindrical portion is usually arranged at an inner side of a skirt portion of the rotor, the balancer cannot project outwards at this portion, so that the balancer necessarily tends to be large in weight.

Then, in order to arrange the balancer without being interfered with by the skirt portion of the spool, it is conceivable to arrange the balancer at a rear end portion (on the side of the spool body) of the rotor. However, since this portion usually is not formed with high manufacturing precision there arises a new problem that the arrangement of the balancer at this position may adversely affect the physical strength of this portion.

Moreover, in disposing the balancer at the rear end portion of the rotor, if the baler is attached here in such a manner as to project significantly from an outer periphery of the rotor, this balancer may come into contact with e.g. an angler's finger in the course of rotation of the rotor.

SUMMARY OF THE INVENTION

Accordingly, a primary object of the present invention is to provide an improved spinning reel of the above type which allows a user of the reel to restrict rotational vibration of the rotor within a permissible range thus allowing smooth line-retrieving operation by well balancing the rotor rotation without sacrificing other functions of the spinning reel.

For a accomplishing the above-noted object, according to the characterizing features of the present invention, a spinning reel comprises:

- a reel body;
- a rotor attached to the reel body and rotatable about a longitudinal axis for retrieving a fishing line; and
- a balancing means attached to the rotor for restricting an imbalance amount of rotation of the rotor substantially within 200 g -mm.

Functions and effect of the above features will be described next.

By using a commercially available rotational balance testing machine the present inventor has conducted intensive experiments with a plurality of spinning reels having rotor diameters ranging approximately between 40 mm and 100 mm. Then, it has been found out that a rotational imbalance amount not exceeding approximately 200 g -mm is sufficient to restrict vibration resulting from the imbalance to such a degree as not to provide discomfort to the user while complete elimination of rotational vibration is yet to be achieved with said amount.

Therefore, the construction of the present invention can achieve practically sufficient performance with the advantage of facility in designing of the rotor in comparison with the conventional construction which involves a great amount of [works] work in designing often with the aid of a computer to determine the appropriate disposing position and the weight of the balancing means.

That is, as described above, through the experiments, the present inventor has come to realize that a rotational imbalance amount not exceeding approximately 200 g -mm is sufficient to restrict vibration resulting from the imbalance to such a degree as not to provide discomfort to the user while complete elimination of rotational vibration is yet to be achieved with said amount.

Then, the inventor proceeded to obtain an amount of deviation in the center of gravity as a value derived by dividing the rotational imbalance amount by [a] the mass of the rotor. Then, it was found that this deviation amount is maintained substantially lower than 3.5 mm in the above-described situation.

Therefore, by restricting the gravity-center deviation amount substantially within 3.5 mm, it is possible to determine a reference value which is independent of the size of the rotor, whereby a more precise rotor balance control becomes possible.

According to a further embodiment of the invention, a spinning reel comprises:

- a reel body;
- a rotor attached to the reel body and rotatable for retrieving a fishing line, the rotor including a base end portion supported to the rotor to be rotatable about a longitudinal axis and a pair of arm portions extending from the base end portion along the longitudinal axis;
- a bail extending between the arm portions;
- the rotor and the bail together constituting a rotary unit having two predetermined positions spaced apart from each other with a predetermined distance therebetween along the longitudinal axis; and
- a balancing means attached to the rotor for restricting an imbalance amount of rotation of the rotor substantially within 200 g -mm at each of the two reference positions.

The above features can achieve the distinguished functions and effects to be described next.

Based on the results of the afore-described experiments by restricting the imbalance amount rotation lower than approximately 200 g -mm at each reference position it becomes possible to reduce a centrifugal force at the rotor face rotating about the longitudinal axis at the respective reference positions thereby to achieve a static balance and also to restrict generation of torque about an axis normal to the longitudinal axis thereby to achieve a dynamic balance.

In short, through the simple arrangement for restricting the rotational imbalance amount within 200 g -mm, in the case also of a rotor having the base end portion and the arm portion disposed side by side along the longitudinal axis, it

has become possible to achieve not only the static balance but also the dynamic balance through the restriction of the torque generation, such that the spinning reel having these features can provide a smooth line retrieving operation without giving the user uncomfortable feel.

Further, and other objects, features and effects of the invention will become more apparent from the following more detailed description of the embodiments of the invention with reference to the accompanying drawings.

BRIEF DESCRIPTION OF THE DRAWINGS

Accompanying drawings illustrate preferred embodiments of the present invention; in which,

FIG. 1 is a side view of a rotor,

FIG. 2 is a front view of the rotor,

FIG. 3 is a plane view of the rotor,

FIG. 4 is a perspective view of an entire spinning reel,

FIG. 5 is a graph showing load-torque characteristics after a balance adjustment,

FIG. 6 is a graph showing load-torque characteristics before the balance adjustment.

FIG. 7 is an overall side view with some parts being cut away,

FIG. 8 is a front view illustrating a further embodiment in which a disposing arrangement of a balancer is modified,

FIG. 9 is a front view showing a condition where a pair of arm portions are sideways displaced from a rotational center relative to the condition shown in FIG. 8,

FIG. 10 is a front view showing a further condition where a balancer having a rotary face at a forward portion thereof is displaced to the opposite side across the rotational center relative to the condition of FIG. 9,

FIG. 11 is a front view of a further embodiment in which a disposing arrangement of the balancer is further modified,

FIG. 12 is an overall side view of a spinning reel relating to the further embodiment,

FIG. 13 is a side view of a spinning reel to a still further embodiment,

FIG. 14 is a front view showing the spinning reel of FIG. 13,

FIG. 15 is a side view showing an entire spinning reel relating to a still further embodiment,

FIG. 16 is a section view showing a click mechanism in the reel of FIG. 15,

FIG. 17 is a side view showing an arrangement of a balancer for a reel relating to a still further embodiment,

FIG. 18 is a side view showing the entire reel of FIG. 17,

FIG. 19 is a plane view showing a control mechanism incorporated in the reel of FIG. 17,

FIG. 20 is a plane view illustrating the control mechanism of the reel of FIG. 17 under a line releasing condition,

FIG. 21 is a side view showing an arrangement of a balancer for a reel relating to a still further embodiment, and

FIG. 22 is a front view showing an arrangement of the balancer of the reel of FIG. 21.

DESCRIPTION OF THE PREFERRED EMBODIMENTS

Preferred embodiments of a spinning reel relating to the present invention will now be described in detail with reference to the accompanying drawings.

A spinning reel relating to a first embodiment is shown in FIGS. 4 and 7. As shown, the spinning reel includes a reel

body 2 having a handle 1. At forward positions of the reel body 2, there are disposed a rotor 4 having a bail 3 and a spool 5 for retrieving an unillustrated fishing line. At other forward positions of the reel body 2, there are also disposed a cylindrical shaft 6 for transmitting a force from the handle to the rotor 4 and a spool shaft 7 which supports a spool 5.

The rotor 4 includes a cylindrical base end portion and a pair of arm portions 4A, 4A extending from the base end portion along a longitudinal axis X. The arm portions 4A, 4A are opposed to each other across the longitudinal axis X. One arm portion 4A carries an arm cam 8 and the other arm portion 4A carries a pivotable arm 9; and the bail 3 is provided between the arm cam 8 and the pivotable arm 9. The bail 3 is switchable between a line releasing position and a line retrieving position.

The arm cam 8 includes a line roller 10 acting as a line guide unit for guiding the fishing line. Further, in this spinning reel, there are provided balancing means B, B at two positions along the longitudinal axis for the purpose of offsetting weight imbalance resulting from the weights of such components as the arm portions 4A, 4A, the bail 3, the arm cam 8, the pivotable arm 9 and the line roller 10.

Particularly, as illustrated in FIGS. 1, 2, 3 and 4, in this reel, there are assumed rotary flat faces S, T which act as reference positions along the longitudinal axis at forward and rear positions with respect to the rotor 4. Then, a moment value is obtained by multiplying the weights of the components including the arm portions 4A, 4A, the bail 3, the arm cam 8, the pivotable arm 9 and the line roller 10 and an arm length extending in a radial direction from the longitudinal axis X where the weights of the components are present. Then, this moment value is divided between lengths corresponding to distances from the center of gravity to the respective rotary flat faces S, T. That is to say, the moment is divided in such a manner that the moment divided between the rotary flat faces S, T will not produce a torque. In this way, the moment values divided between the flat faces S, T are composed within the rotary flat faces. This composite moment is considered as an imbalance rotation amount between the two rotational flat faces S, T. Then, by disposing the balancing means B at appropriate positions, these balancing means B produce a counter moment for offsetting the composite moment.

Then as illustrated in FIG. 2, the pair of arm portions 4A, 4A are displaced by a predetermined amount D relative to the longitudinal axis X thereby to form the one balancing means B and also, as illustrated in FIG. 3, two balancers 11, 11 are disposed at the base end portion to form the other balancing means B.

That is to say, a point PS subjected to the above-described composite moment is displaced towards the bail 3 relative to the longitudinal rotational axis X. Therefore, the displacement amount D at the pair of arm portions 4A, 4A is so set as to locate a center of gravity QS of the balancing means B at a position opposed to the position of the point PS across the axis X.

The balancers 11, 11 are -disposed outwardly of an outer periphery of the rotor 4 and also inwardly of a rotational path U of an outer peripheral portion of the arm portion 4A, as viewed from the direction of the longitudinal rotational axis X. This can prevent contact between e.g. a user's finger and the balancers during a line retrieving operation. That is, the arrangement not only reduces the weights of the balancers 11, 11 but also prevents the contact between the finger and the balancers without requiring any special elements for these purposes.

Incidentally, on this rotational flat face the point PT subjected to the composite moment appears as shown in FIG. 2. So, that the balancers 11, 11 are disposed as to cause a composite gravity center QT of these two balancers 11, 11 to appear at the position opposed to the point PT across the rotational axis X.

As a result, when a fishing line retrieving operation is effected by rotating the handle of this reel, this line retrieving operation can be effected in a smooth manner because of the rotational balance maintained at the forward and rear positions of the rotor 4. During a line casting operation also, it is possible to restrict rotational irregularity due to imbalance of the rotor 4.

Further, since the balancer 11 is disposed at the rear end side of the rotor 4, as compared with the conventional reel construction of this type, it is possible to dispose the balancer 11 farther away from the axis X. Thus, the weight reduction of the balancer 11 does not result in deterioration in the strength of the rotor 4.

If the balancing means B is so arranged as to restrict the rotational imbalance amount at the rotational flat faces S, T within 200 g -mm, then, it becomes possible to achieve not only a static balance but also a dynamic balance of the rotor 4. Consequently, the line retrieving operation using the handle can be effected smoothly. Further, during the casting operation too, rotational vibration due imbalance of the rotor 4 can be effectively restricted.

Experiments were conducted by comparing vibration characteristics of a spinning reel having the imbalance amount at the reference positions set at 6 g -mm (a deviation amount of gravity center not exceeding 1 mm) and the same spinning reel having the imbalance amount exceeding 200 g -mm before the balancing adjustment. The results are shown in FIGS. 4 through 6. More particularly, as illustrated in FIG. 4, a sensor is set to sense vibration at a leg portion of the reel to be attached to a fishing rod. Using this sensor, vibration characteristics in directions (a), (b) and (c) are obtained. The illustrated characteristics comprise those in the direction (a) where the vibration affects in the right and left directions of the reel. As shown in FIGS. 5 and 6, a dot line denotes a load while a solid line denotes a torque about the direction (a). It may be seen that variation in the load and variation in the torque are both reduced. In the vibration characteristics in the other directions (b), (c) too, the load and torque variations are reduced. These [ape] are not illustrated.

Incidentally, in order to further restrict rotation of the rotor 4 during a line casting operation, as shown in FIGS. 4 and 7, in this spinning reel, a further balancer 1C is provided on the side opposed to a grip portion 1B in order to offset the weights of the arm portions 1A and the grip portions 1B of the handle 1. With this, imbalance of the handle 1 relative to the handle shaft [1] can be corrected so that the handle 1 can be prevented from being rotated during the casting operation.

Next, further embodiments of the present invention 65 will be specifically described.

(1) The balancer 11 can be disposed at a plurality of positions along the longitudinal axis.

(2) In case the rotor 4 has a relatively short axial length, only one reference position will suffice for the detecting of the imbalance amount.

(3) It is conceivable to standardize the reference value usable regardless of possible difference in the mass of the rotor 4. In this case, the reference value will be obtained by dividing the reference imbalance amount of 200 g -mm by the mass of the rotor 4 (generally referred to as a center of

gravity deviation). In practice, it is preferred that the imbalance amount not exceed 60 g-mm and the [gravity] center of gravity deviation amount not exceed 2 mm. Further, by considering a rotational velocity of the rotor 4 during a line retrieving operation in addition to the size of the rotor 4, it becomes possible to control the rotational imbalance amount according to the JIS standards (Japanese Industrial Standards). Specifically, the [gravity] center of gravity deviation amount is multiplied by the rotational velocity to produce a value. Then, by maintaining this value within a range between 16 and 40 mm/s, it is possible to cause the rotational performance of the rotor 4 to substantially comply with the 6th grade of the JIS.

(4) As illustrated in FIG. 8, it is conceivable to form the balancing means B by disposing the balancer 11S at a forward side of the rotational flat face S in place of the displacement of the disposing positions of the pair of arm portions 4A, 4A (i.e. the offset arrangement as shown in FIG. 2). Further, as shown in the same drawing, it is also conceivable to dispose a single balancer 11T at a rear side of a rotational flat face T.

(5) FIG. 9 shows a further construction of the balancing means B. In this case, relative to the condition of FIG. 8, the pair of arm portions 4A, 4A are displaced sideways by an amount D relative to the rotational center and a balancer 11S is provided on a front side rotational flat face S. Alternately, it is conceivable to provide the single balancer 11T in the rear side rotational flat face T.

(6) FIG. 10 shows a still further construction of the balancing means B. In this case, relative to the condition of FIG. 9, the pair of arm portions 4A, 4A are further displaced sideways by a larger amount E relative to the rotational center and the balancer 11S is provided on the side opposite across the rotational center to the displaced positions of the arm portions 4A, 4A in the forward side rotational flat face S. As also shown in this FIG. 10, it is conceivable to provide the single balancer in the rear side rotational flat face T.

(7) FIG. 11 shows a further construction. In this, the balancers 11, 11 are provided respectively inside the arm portion 4A of the rotor 4 and at [9] a peripheral portion of this rotor 4 with the balancers 11, 11 forming an angle (α) smaller than 90 degrees in the direction along the axis X. Further, the balancer 11 disposed at the peripheral portion of the rotor 4 has a weight greater than that of the other balancer 11 disposed inside the rotor 4. This construction has the advantage of allowing reduction in the weight and the size of the balancer 11 disposed inside the rotor 4 thus facilitating arrangement of other components such as a toggle spring inside the arm portion 4A.

The invention provides a further embodiment designed for further restriction of rotation of the rotor 4 during a casting operation. That is, as illustrated in FIG. 12, the handle 1 includes a pair of arm portions 1A, 1A having [a] the same length and a pair of grip portions 1B, 1B having [a] the same weight. With this, it is possible to further avoid imbalance of the handle 1 relative to the handle shaft thereby to prevent rotation of the handle 1 as well during the casting operation.

FIGS. 13 and 14 illustrate a further embodiment of the present invention. In this construction the balancers 11, 11 are disposed adjacent the rear end portion of the rotor 4 on the same side as the gravity center WP of the rotor 4 as viewed in the direction along the rotational axis X. So [that], a composite gravity center WX of the gravity center WP of the rotor 4 and the gravity center W1 of the balancers 11, 11 is fed at an intermediate 10 position along the rotor axis X.

Then, a further balancer **11'** is disposed to provide a gravity center **W2** at a position opposed to the position of the composite gravity center **WX** for offsetting the magnitude of this composite gravity center **WX**. Further, as shown in the same drawings, it is also conceivable to form, on a rear face side adjacent the rear end of the rotor **4**, a plurality of concave portions **4B** for accommodating the balancers **11** in order to allow selective arrangement of the balancers **11** in accordance with possible irregularities present in the reel product.

A still further construction shown in FIG. **15** is possible for further restricting rotation of the rotor **4** during a casting operation. That is, in this reel construction, the balancer **1C** is provided on the side opposed to the grip portion **1B** in order to offset the weights of the arm portion **1A** and the grip portion **1B** of the handle **1**. This construction too can solve the problem of imbalance of the handle **1** relative to the handle shaft thus preventing rotation of the handle **1** during the casting operation.

In FIG. **16**, a reference numeral **12** denotes a click sound generating mechanism projectable and retractable relative to a disc **15** interposed between a friction plate **13** and a drag control element **14** of a drag mechanism. This mechanism generates a clocking sound through engagement and disengagement with and from uneven faces **5A** defined inside the spool **5** when there occurs a sliding movement inside the drag mechanism.

A further embodiment of the present invention will be described next.

A construction of a spinning reel of this further embodiment is as follows. A line roller is provided at a pivotable arm attached to the arm portion of the rotor. At one end of this line roller, there is supported a bail. Further, by using as a reference the pivotable arm having the line roller, a first balancer is provided at a portion closer to the reel body than to the pivotable arm. And, at a position opposed, across the axis, to a composite gravity center composed of the gravity center of the components disposed on the side of the pivotable arm and the gravity center of the first balancer and at an arm portion disposed to the pivotable arm, there is provided a second balancer having a weight for offsetting the composite gravity center.

With the above-described construction, as illustrated in FIG. **17**, the first balancer **20** is disposed on the same side as the gravity center **WP** of the components including the pivotable arm with respect to the axis **X**, such that the composite gravity center **WX** composed of the gravity center **WP** and the gravity center **W1** of the first balancer **20** appears at a position between the two gravity centers. Then, the second balancer **21** having the appropriate weight is provided for offsetting the composite gravity center **WX** by setting a composite gravity center **WX'** composed of a gravity center **WP'** of the pivotable arm on this side and of its gravity center **W2** on a rotational path of the above-described composite gravity center **WX**. Accordingly, the weights are balanced in the direction along the rotational axis **X**. Moreover, since the respective composite gravity centers **WX**, **WX'** are positioned on the same rotational path, there occurs no torque or the like during the rotation of the rotor **4**.

FIG. **17** illustrates moment values of the above balanced condition relative to the axis **X**. As shown, a moment value **U1** resulting from the weight of the first balancer **20**, a moment value **U2** resulting from the weight of the second balancer **21** and a further moment value **UP'** resulting from the weight of the pivotable arm **9'** are balanced with one another.

That is to say, by disposing the first balancer **20** on the heavier side instead of providing a single balancer, the composite gravity center **WX** is displaced towards the reel body **2**. Consequently, even if the second balancer **21** can be provided to the rotor **4**, this second balancer **21** can be arranged at such position as to offset the weight of this composite gravity center **WX**.

The rotor **4** includes the pair of arm portions **4A**, **4A** at positions opposed to the other across the axis **X**. Further, for the pivotable arms **9**, **9'** attached to the respective arm portions **4A**, **4A**, there is attached the bail **3** which is switchable between a line releasing position and a line retrieving position.

Further, one of the pivotable arms **9**, **9'** includes the line roller **10** for guiding the fishing line and a control mechanism **A** for switching the bail **3** to the releasing position by one step operation. Then, in this reel, there is provided the balancing means for offsetting imbalance in the weights of the components including the line roller **10**, the control mechanism **A**.

Specifically, by using as a reference the gravity center **WP** of the weights of the components **10**, **A**, etc., the first balancer **20** is provided at the arm portion **4A** of the rotor **4** on the side of the reel body **2**. Further, with respect to the composite gravity center **WX** composed of the gravity center **WP** of the components and the gravity center **W1** of the first balancer **20**, at an opposite position across the axis **X** and at the arm portion **4A** opposed to the pivotable arm **9**, there is provided the second balancer **21** having an appropriate weight at a position on the rotational path of the composite gravity **WX** composed of the gravity center **WP'** of the pivotable arm **9'** on this side and of its gravity center **W2** in order to offset said composite gravity center **WX** during rotation of the rotor **4**.

Through the above described arrangements of the respective balancers **20**, **21**, the weights are balanced with each other in the direction along the axis **X**. Further, since the second balancer **21** is disposed at the position for offsetting the weight of the gravity center **WX**, even when a mechanical looseness is developed at the support construction for the rotor **4**, there occurs no vibration during the of rotation of the rotor **3**, whereby a smooth line retrieving action is possible.

Incidentally, the control mechanism **A** includes a lever **22** pivotably attached to the arm portion **4a** of the rotor **4** to be pivotable about an axis **Y** and a cam element **23** operable to switch the pivotable arm **9** through contact with the lever **22** when this lever **22** is operated upwards.

Inside the arm portion **4A** of this side there is incorporated a toggle spring **24** for urgedly maintaining the pivotable arm **9** at either the line releasing position or the line retrieving position. And, this spring **24** is covered with a cover **25**.

A still further embodiment of the present invention will be described next.

According to a reel of this embodiment, the line roller is provided to the pivotable arm attached to the arm portion of the rotor, with one end of the bail being supported to this line roller. Further, the first balancer is provided to the rotor on the side where the bail at its line retrieving position is located in the direction along the axis. Also, relative to a composite gravity center composed of the gravity center of the components formed on the pair of arm portions and that of the first balancer, the second balancer is provided at a position opposed to the composite gravity center across the axis in order to offset the composite gravity center.

With the above-described construction, as illustrated in FIGS. **21** and **22**, the first balancer **20** is arranged on the

same side as the bail **3** with respect to the axis X. So that, although the gravity center WP of the components attached to the bail **3** and the pair or arm portions **4A**, **4A** is positioned at a relatively forward portion of the reel, the composite gravity center WX composed of said gravity center WP and of the gravity center W1 of the first balancer **20** is shifted towards the reel body, whereby the weights are balanced with each other in the direction along the axis. Moreover, since the second balancer **21** is arranged on the rotation path of the composite gravity center WX, there occurs no torque during the rotation of the rotor **4**.

That is to say, in the case of the above construction too, by arranging the first balancer **20** on the heavier side in place of providing a single balancer, the composite gravity center WX is displaced towards the reel body **2**. Consequently, even when the second balancer **21** is to be attached to the rotor **4**, this second balancer **21** can be disposed at a position offsetting the composite gravity WX.

Accordingly, through the unique arrangements of the balancers, the spinning reel of the present invention can provide a smooth line retrieving action without causing uncomfortable vibration e.g. on the fishing rod even if a high-speed line retrieving action is effected after a mechanical looseness is developed in the reel through its use for an extended period of time.

In this embodiment, as shown in FIGS. **21** and **22**, there is provided [the] a difference in the arrangement of the balancer at the portion of the rotor **4**.

That is, the first balancer **20** is disposed at a position of the rotor **4**, where the bail **3** at its line retrieving position is located in the direction along the axis X, displaced relative to the reel body **2**. Further, with respect to the composite gravity center WX composed of the gravity center WP of the weights of the components such as the bail **3**, the pivotable arm **9**, the line roller **10** and so on and of the gravity center W1 of the first balancer **20**, at a position opposed to the composite gravity center WX across the axis X, there is provided the second balancer **21** having the weight capable of offsetting said composite gravity center WX during the rotation of the rotor **4**.

Through the above described arrangements of the respective balance **20**, **21**, the weights in the direction along the axis are balanced with each other. Further, since the second balancer **21** is located at the position capable of offsetting the weight of the composite gravity center WX, the reel can provide a smooth line retrieving operation without causing vibration during the rotor rotation even after a mechanical looseness has developed in the support construction for the rotor **4**.

In addition to the above-described various embodiments, further modified constructions are conceivable. For instance, it is conceivable to embed the balancers in the rotor **4**. Further, the cover member **25** can be formed of heavy material so that this member can act also as the first balancer. Moreover, it is conceivable to render the balancers adjustable in their positions.

The invention may be embodied in other specific forms without departing from the spirit or essential characteristics thereof. The present embodiments are therefore to be considered in all respects as illustrative and not restrictive, the scope of the invention being indicated by the appended claims rather than by the foregoing description and all changes which come within the meaning and range of equivalency of the claims are therefore intended to be embraced therein.

What is claimed is:

[1. A spinning reel comprising:

a reel body **(2)**;

a spool mounted on said reel body;

a rotor attached to said reel body, said rotor being rotatable about a rotor axis (X) said rotor including:

a base end portion;

a first arm portion extending from said base end portion, said first arm portion being substantially parallel to said rotor axis, said first arm portion having a top end; and

a second arm portion, said second arm having a top end, said first and second arm portions being on opposite sides of said rotor axis;

a handle for rotating said rotor, said handle being attached to said reel body;

a first pivotal arm **(9)** attached to said top end of said first arm portion, said first pivotal arm being rotatable about a first transverse axis;

a second pivotal arm **(9')** attached to said top end of said second arm portion, said second pivotal arm being rotatable about a second transverse axis;

a bail extending between said first and second pivotal arms **(9, 9')**, said bail being pivotal with said pivotal arms between retrieving and releasing positions, and wherein said bail projects radially away from said rotor axis (X) in said retrieving position, said bail in said retrieving position being located on a first side of a reference plane in which said rotor axis (X) lies; and

a first balancer **(20)** for facilitating counterbalancing of said bail in said retrieving position, said balancer being located at said base end portion of said rotor, and the center of gravity of said balancer being located on said first side of said reference plane.]

2. A spinning reel as defined in claim **[1]** **30**, wherein said balancer includes a weight located entirely on said first side of said reference plane.

3. A spinning reel as defined in claim **[1]** **30**, further comprising correcting means for counterbalancing said first balancer **[(20)]** and said bail **[(3)]** in said retrieving position, said correcting means being located on a second side of said reference plane.

4. A spinning reel as defined in claim **3**, wherein said correcting means includes a second balancer **[(21)]**, said second balancer being located on said second side of said reference plane, the axial position of said second balancer **[(21)]** with respect to said rotor axis **[(X)]** being between the respective axial positions of said first balancer **[(20)]** and said bail in said retrieving position.

5. A spinning reel as defined in claim **3**, wherein said correcting means offsets at least one of said transverse axes to said second side of said reference plane.

6. A spinning reel as defined in claim **3**, wherein said correcting means offsets said first and second arm portions to said second side of said reference plane.

[7. A spinning reel comprising:

a reel body **(2)**;

a spool mounted on said reel body;

rotor attached to said reel body, said rotor being rotatable about a rotor axis (X); said rotor including:

a base end portion;

a first arm portion extending from said base end portion, said first arm portion being substantially parallel to said rotor axis, said first arm portion having a top end; and

11

a second arm portion having a top end, said first and second arm portions being located on substantially opposite sides of said rotor axis;

a handle for rotating said rotor, said handle being attached to said reel body;

a first pivotal arm (8) attached to said top end of said first arm portion, said first pivotal arm being rotatable about a first transverse axis;

a second pivotal arm (9) attached to said top end of said second arm portion, said second pivotal arm being rotatable about a second transverse axis;

a guiding portion (10) attached to said first pivotal arm (8);

a bail extending between said first and second pivotal arms (8, 9), said bail being pivotable with said pivotal arms between retrieving and releasing positions, and wherein said bail projects radially away from said rotor axis (X) in said retrieving position, said bail in said retrieving position being located on a first side of a reference plane in which said rotor axis (X) lies; and

a first balancer (11(B)) for facilitating counterbalancing of said line guiding portion and said bail (3) in said retrieving position, said balancer being located at said base end portion of said rotor, the center of gravity of said balancer being located on said first side of said reference plane, and the center of gravity of said balancer being closer to said first arm portion (8) than to said second arm portion (9).]

8. A spinning reel as defined in claim [7] 31, further comprising correcting means for counterbalancing said first balancer [(11(B))] and said bail [(3)] in said retrieving position, said correcting means being located on a second side of said reference plane.

9. A spinning reel as defined in claim 8, wherein said correcting means includes a second balancer, said second balancer being located on said second side of said reference plane, the axial position of said second position with respect to said rotor axis [(X)] being between the respective axial positions of said first balancer [(11(B))] and said bail in said retrieving position.

10. A spinning reel as defined in claim 8, wherein said correcting means offsets at least one of said transverse axes to said second side of said reference plane.

11. A spinning reel as defined in claim 8, wherein said correcting means offsets said first and second arm portions to said second side of said reference plane.

12. A spinning reel comprising:

- a reel body;
- a spool mounted on said reel body;
- a rotor attached to said reel body, said rotor being rotatable about a rotor axis [(X)], said rotor including:
 - a cylindrical base end portion;
 - a first supporting arm extending from said base end portion, said supporting arm being substantially parallel to said rotor axis, said supporting arm having a top end; and
 - a second supporting arm extending from said base end portion, said second supporting arm being substantially parallel to said rotor axis, said second supporting arm having a top end;
- a handle for rotating said rotor, said handle being attached to said reel body;
- a first pivotal arm [(8)] attached to said top end of said first supporting arm, said pivotal arm being rotatable about a first transverse axis;

12

- a second pivotal arm [(9)] attached to said top end of said second supporting arm, said second pivotal arm being rotatable about a second transverse axis;
- a bail extending between said first and second pivotal arms, said bail being pivotable with said pivotal arms between retrieving and releasing positions, and wherein said bail projects radially away from said rotor axis [(X)] in said retrieving position, said bail in said retrieving position being located *substantially* on a first side of a reference plane in which said rotor axis [(X)] lies;

first balancer means located at said base end portion and on said first side of said reference plane, said first balancer means including a weight; and

second balancer means axially spaced apart from said first balancer means with respect to said rotor axis, said second balancer means being arranged such that at least one of said transverse axes is offset to a second side of said reference plane.

13. A spinning reel as defined in claim [12] 32, further comprising a third balancer means including a weight, the axial position of said third balancer means with respect to said rotor axis being between the respective axial positions of said first and second balancer means.

14. A spinning reel as defined in claim 13, wherein said weight of said third balancer means is provided at an outer peripheral area of said rotor.

15. A spinning reel as defined in claim [12] 32, wherein said first and second supporting arms are offset toward said second side of said reference plane.

16. A spinning reel comprising:

- a reel body;
- a spool mounted on said reel body;
- a rotor attached to said reel body, said rotor being rotatable about a rotor axis [(X)], said rotor including:
 - a cylindrical base end portion;
 - a first supporting arm extending from said base end portion, said supporting arm being substantially parallel to said rotor axis, said supporting arm having a top end; and
 - a second supporting arm extending from said base end portion, said second supporting arm being substantially parallel to said rotor axis, said second supporting arm having a top end;
- a handle for rotating said rotor, said handle being attached to said reel body;
- a first pivotal arm [(8)] attached to said top end of said first supporting arm, said pivotal arm being rotatable about a first transverse axis;
- a line roller attached to said first pivotal arm;
- a second pivotal arm [(9)] attached to said top end of said second supporting arm, said second pivotal arm being rotatable about a second transverse axis;
- a bail extending between said first and second pivotal arms, said bail being pivotable with said pivotal arms between retrieving and releasing positions, and wherein said bail projects radially away from said rotor axis [(X)] in said retrieving position, said bail in said retrieving position being located *substantially* on a first side of a reference plane in which said rotor axis [(X)] lies;

first balancer means located at said base end portion, on said first side of said reference plane, and closer to said first supporting arm than to said second supporting arm, said first balancer means including a weight; and

13

second balancer means axially spaced apart from said first balancer means with respect to said rotor axis, said second balancer means being arranged such that at least one of said transverse axes is offset to a second side of said reference plane.

17. A spinning reel as defined in claim [16] 33, wherein said weight of said first balancer means is positioned in a region where said first supporting arm and said base end portion of said rotor are connected.

18. A spinning reel as defined in claim 17, wherein said first balancer means includes a second weight, said second weight being located at said base end portion and on said first side of said reference plane, the distance between said second weight and said reference plane being greater than the distance between said first weight and said reference plane.

19. A spinning reel as defined in claim 18, further comprising a third balancer means including a weight, the axial position of said third balancer means with respect to said rotor axis being between the respective axial positions of said first and second balancer means.

20. A spinning reel as defined in claim 19, wherein said weight of said third balancer means is provided at an outer peripheral area of said rotor.

21. A spinning reel as defined in claim [16] 32, further comprising a third balancer means including a weight, the axial position of said third balancer means with respect to said rotor axis being between the respective axial positions of said first and second balancer means.

22. A spinning reel as defined in claim 21, wherein said weight of said third balancer means is provided at an outer peripheral area of said rotor.

23. A spinning reel comprising:

a reel body [(2)];

a spool mounted on said reel body;

a rotor [(4)] for retrieving a fishing line, said rotor being rotatable about a rotor axis, said rotor including:

a base end portion; and

first and second arm portions [(4A, 4A)] extending from said base end portion, said arm portions being substantially parallel to said rotor axis;

a handle for rotating said rotor, said handle being pivotally attached to said reel body [(2)];

elements asymmetrically positioned with respect to said rotor axis, said elements including

first and second pivot arms [(8,)],

a line roller [(10)] formed on said first pivot arm [(8)],

a bail [(3)] extending between said line roller [(10)] and said second pivot arm, said pivot arms being rotatable about transverse axes, said bail having a retrieving position, and said bail in said retrieving position

extending in a substantially radial direction with respect to said rotor axis, and said bail in said retrieving position being located *substantially* on a first side of a reference plane in which said rotor axis [(X)] lies; and

balancing means [(B)] for at least partially counterbalancing said asymmetrically positioned elements, said balancing means including:

first balance means arranged such that said transverse axes are shifted to a second side of said reference plane; and

second balance means located at said base end portion and on said first side of said reference plane.

24. A spinning reel as defined in claim [23] 34, wherein said second balance means includes a weight located entirely on said first side of said reference plane.

14

25. A spinning reel as defined in claim [23] 34, wherein said second balance means is a weight.

26. A spinning reel as defined in claim [23] 34, wherein said balancing means [(B)] includes a third balance means disposed a predetermined distance away from said base end portion in a direction substantially parallel to said rotor axis [(X)], said third balance means being located on said second side of said reference plane.

27. A spinning reel as defined in claim 26, wherein said third balance means is a weight.

[28. A spinning reel comprising:

a reel body (2);

a spool mounted on said reel body;

a rotor (4) rotatable around a rotor axis, said rotor including:

a rotor base end portion;

a rotor drum extending forwardly from said base end portion in a fishing line draw out direction;

a first arm disposed outside of said rotor drum, said arm having a free end; and

a second arm having a free end, said first and second arms being on substantially opposite sides of said rotor axis;

a handle for rotating said rotor, said handle being attached to said reel body (2);

a bail pivotally connected to said free ends of said first and second arms, said bail being pivotable around a second axis between a retrieving position and a non-retrieving position, said bail being located on a first side of an imaginary plane in which said rotor axis lies, said second axis being located on a second side of said plane, said second axis being substantially parallel to said plane, and said second axis being spaced apart from said plane;

a first weight disposed at said base end portion of said rotor and on said first side of said imaginary plane; and

a second weight disposed on said second side of said imaginary plane, said second weight being closer along said rotor axis to said bail than said first weight is to said bail.]

[29. A spinning reel comprising:

a reel body;

a spool mounted on said reel body;

a rotatable rotor disposed on said reel body, said rotor including:

first and second arm portions; and

an arm cam pivotally disposed at said first arm portion, and a pivot arm pivotally disposed at said second arm portion;

a handle for rotating said rotor, said handle being pivotally attached to said reel body;

a bail fixedly connected to said arm cam and said pivot arm, said bail along with said arm cam and said pivot arm being shiftable between line retrieving and line releasing positions, said bail in said line retrieving position being located on a first side of a reference plane in which said rotor axis lies, said arm portions being located on a second side of said reference plane to counterbalance said bail in said line retrieving position; and

a balance weight for counterbalancing said arm portions, said balance weight being disposed on said first side of said reference plane.]

15

30. A spinning reel, comprising:
 a reel body;
 a spool mounted on said reel body;
 a rotor attached to said reel body, said rotor being rotatable about a rotor axis, said rotor including:
 a base end portion;
 a first arm portion extending from said base end portion, said first arm portion being substantially parallel to said rotor axis, said first arm portion having a top end; and
 a second arm portion having a top end, said first and second arm portions being on opposite sides of said rotor axis;
 a handle for rotating said rotor, said handle being attached to said reel body;
 a first pivotal arm attached to said top end of said first arm portion, said first pivotal arm being rotatable about a first transverse axis;
 a second pivotal arm attached to said top end of said second arm portion, said second pivotal arm being rotatable about a second transverse axis;
 a bail extending between said first and second pivotal arms, said bail being pivotable with said pivotal arms between retrieving and releasing positions, and wherein said bail projects radially away from said rotor axis in said retrieving position, said bail in said retrieving position being located on a first side of a reference plane in which said rotor axis lies; and
 a first balancer for facilitating counterbalancing of said bail in said retrieving position, said balancer being located at said base end portion of said rotor, and the center of gravity of said balancer being located on said first side of said reference plane.

31. A spinning reel, comprising:
 a reel body;
 a spool mounted on said reel body;
 a rotor attached to said reel body, said rotor being rotatable about a rotor axis, said rotor including:
 a base end portion;
 a first arm portion extending from said base end portion, said first arm portion being substantially parallel to said rotor axis, said first arm portion having a top end; and
 a second arm portion having a top end, said first and second arm portions being located on substantially opposite sides of said rotor axis;
 a handle for rotating said rotor, said handle being attached to said reel body;
 a first pivotal arm attached to said top end of said first arm portion, said first pivotal arm being rotatable about a first transverse axis;
 a second pivotal arm attached to said top end of said second arm portion, said second pivotal arm being rotatable about a second transverse axis;
 a line guide portion attached to said pivotal arm;
 a bail extending between said first and second pivotal arms, said bail being pivotable with said pivotal arms between retrieving and releasing positions, and wherein said bail projects radially away from said rotor axis in said retrieving position, said bail in said retrieving position being located on a first side of a reference plane in which said rotor axis lied; and
 a first balancer for facilitating counterbalancing of said line guide portion and said bail in said retrieving

16

position, said balancer being located at said base end portion of said rotor, the center of gravity of said balancer being located on said first side of said reference plane, and the center of gravity of said balancer being closer to said first arm portion than to said second arm portion.

32. A spinning reel, comprising:
 a reel body;
 a spool mounted on said reel body;
 a rotor attached to said reel body, said rotor being rotatable about a rotor axis, said rotor including:
 a cylindrical base end portion;
 a first supporting arm extending from said base end portion, said supporting arm being substantially parallel to said rotor axis, said supporting arm having a top end; and
 a second supporting arm extending from said base end portion, said second supporting arm being substantially parallel to said rotor axis, said second supporting arm having a top end;
 a handle for rotating said rotor, said handle being attached to said reel body;
 a first pivotal arm attached to said top end of said first supporting arm, said pivotal arm being rotatable about a first transverse axis;
 a second pivotal arm attached to said top end of said second supporting arm, said second pivotal arm being rotatable about a second transverse axis;
 a bail extending between said first and second pivotal arms, said bail being pivotable with said pivotal arms between retrieving and releasing positions, and wherein said bail projects radially away from said rotor axis in said retrieving position, said bail in said retrieving position being located on a first side of a reference plane in which said rotor axis lies;
 first balancer means located at said base end portion and on said first side of said reference plane, said first balancer means including a weight; and
 second balancer means axially spaced apart from said first balancer means with respect to said rotor axis, said second balancer means being arranged such that at least one of said transverse axes is offset to a second side of said reference plane.

33. A spinning reel, comprising:
 a reel body;
 a spool mounted on said reel body;
 a rotor attached to said reel body, said rotor being rotatable about a rotor axis, said rotor including:
 a cylindrical base end portion;
 a first supporting arm extending from said base end portion, said supporting arm being substantially parallel to said rotor axis, said supporting arm having a top end; and
 a second supporting arm extending from said base end portion, said second supporting arm being substantially parallel to said rotor axis, said second supporting arm having a top end;
 a handle for rotating the rotor, said handle being attached to said reel body;
 a first pivotal arm attached to said top end of said first supporting arm, said pivotal arm being rotatable about a first transverse axis;
 a line roller attached to said first pivotal arm;
 a second pivotal arm attached to said top end of said second supporting arm, said second pivotal arm being rotatable about a second transverse axis;

17

a bail extending between said first and second pivotal arms, said bail being pivotable with said pivotal arms between retrieving and releasing positions, and wherein said bail projects radially away from said rotor axis in said retrieving position, said bail in said 5 retrieving position being located on a first side of a reference plane in which said rotor axis lies;

first balancer means located at said base end portion, on said first side of said reference plane, and closer to said first supporting arm than to said second supporting 10 arm, said first balancer means including a weight; and second balancer means axially spaced apart from said first balancer means with respect to said rotor axis, said second balancer means being arranged such that at least one of said transverse axes is offset to a second 15 side of said reference plane.

34. A spinning reel, comprising:

a reel body;

a spool mounted on said reel body;

a rotor for retrieving a fishing line, said rotor being rotatable about a rotor axis, said rotor including:

a base end portion; and

first and second arm portions extending from said base end portion, said arm portions being substantially 25 parallel to said rotor axis;

a handle for rotating said rotor, said handle being pivotally attached to said reel body;

elements asymmetrically positioned with respect to said rotor axis, said elements including:

first and second pivot arms;

a line roller formed on said first pivot arm;

a bail extending between said line roller and said second pivot arm, said pivot arms being rotatable 35 about transverse axes, said bail having a retrieving position, and said bail in said retrieving position extending in a substantially radial direction with respect to said rotor axis, and said bail in said retrieving position being located on a first side of a reference plane in which said rotor axis lies; and 40

balancing means for at least partially counterbalancing said asymmetrically positioned elements, said balancing means including:

first balance means arranged such that said transverse 45 axes are shifted to a second side of said reference plane; and

second balance means located at said base end portion and on said first side of said referenced plane.

35. A spinning reel, comprising:

a reel body;

a spool mounted on said reel body;

a rotor rotatable about a rotor axis, said rotor including:

18

a rotor base end portion;

a rotor drum extending forwardly from said base end portion in a fishing line draw out direction;

a first arm disposed outside of said rotor drum, said arm having a free end; and

a second arm having a free end, said first and second arms being on substantially opposite sides of said rotor axis;

a handle for rotating said rotor, said handle being attached to said reel body;

a bail pivotally connected to said free ends of said first and second arms, said bail being pivotable around a second axis between a retrieving position and a non-retrieving position, said bail being located on a first side of an imaginary plane in which said rotor axis lies, said second axis being located on a second side of said plane, said second axis being substantially parallel to said plane, and said second axis being spaced apart from said plane;

a first weight disposed at said base end portion of said rotor and on said first side of said imaginary plane; and

a second weight disposed on said second side of said imaginary plane, said second weight being closer along said rotor axis to said bail than said first weight is to said bail.

36. A spinning reel, comprising:

a reel body;

a spool mounted on said reel body;

a rotatable rotor disposed at said reel body, said rotor including:

first and second arm portions;

an arm cam pivotally disposed on said first arm portion; and

a pivot arm pivotally disposed at said second arm portion;

a handle for rotating said rotor, said handle being pivotally attached to said reel body;

a bail fixedly connected to said arm cam and said pivot arm, said bail along with said arm cam and said pivot arm being shiftable between line retrieving and line releasing positions, said bail in said line retrieving position being located on a first side of a reference plane in which said rotor axis lies, said arm portions being located on a second side of said reference plane to counterbalance said bail in said line retrieving position; and

a balance weight for counterbalancing said arm portions, said balance weight being disposed on said first side of said reference plane.

* * * * *