



US00RE38084E

(19) **United States**
(12) **Reissued Patent**
Hashizume et al.

(10) **Patent Number:** **US RE38,084 E**
(45) **Date of Reissued Patent:** **Apr. 22, 2003**

(54) **PROJECTOR**
(75) Inventors: **Toshiaki Hashizume**, Suwa (JP);
Hisashi Iechika, Suwa (JP); **Yasunori**
Ogawa, Suwa (JP); **Shinji Haba**, Suwa
(JP); **Akitaka Yajima**, Suwa (JP)

5,278,680 A 1/1994 Karasawa et al.
5,418,583 A 5/1995 Masumoto 353/38
5,626,409 A 5/1997 Nakayama et al. 353/37
5,662,401 A 9/1997 Shimizu et al. 353/38

(73) Assignee: **Seiko Epson Corporation**, Tokyo (JP)
(21) Appl. No.: **09/774,645**
(22) Filed: **Feb. 1, 2001**

FOREIGN PATENT DOCUMENTS

EP 0 526 653 A1 2/1993
EP 0 646 828 A1 4/1995
EP 0 803 754 A1 10/1997
JP A-63-123019 5/1988
JP 3-111806 5/1991
JP A-5-72455 3/1993
JP A-6-202094 7/1994

Related U.S. Patent Documents

Reissue of:
(64) Patent No.: **5,865,521**
Issued: **Feb. 2, 1999**
Appl. No.: **08/912,565**
Filed: **Aug. 18, 1997**

Primary Examiner—William Dowling
(74) *Attorney, Agent, or Firm*—Oliff & Berridge, PLC

(57) **ABSTRACT**

(30) **Foreign Application Priority Data**

Aug. 19, 1996 (JP) 8-217652
Jul. 15, 1997 (JP) 9-190004

An output light from an light source lamp unit **8** in a projection-type display apparatus illuminates liquid-crystal light valves **925R**, **925G** and **925B** for three colors via an integrator optical system **923**. A superimposing lens **930** that is a component of the integrator optical system **923** as a uniform illumination optical system is arranged such that the mounting position of the superimposing lens **930** is fine-adjustable in a direction orthogonal to an optical axis **1a**. By fine-adjusting the mounting position of the superimposing lens **930**, the position of an illumination area **B** is adjusted such that the illumination area includes the image forming area **A** of the liquid-crystal light valve. It is not necessary to assure a wide margin around the image forming area **A** to cover the offset of the position of the illumination area **B**. As a result, the utilization of illumination light is heightened and a bright projected image results.

(51) **Int. Cl.**⁷ **G03B 21/14**
(52) **U.S. Cl.** **353/101**; 353/119; 353/38;
353/20; 353/31; 353/37; 349/9
(58) **Field of Search** 353/20, 31, 33,
353/34, 37, 38, 69, 70, 98, 101, 119

(56) **References Cited**

U.S. PATENT DOCUMENTS

4,645,319 A 2/1987 Fekete
5,098,184 A 3/1992 Van Den Brandt et al. ... 353/38
5,153,752 A 10/1992 Kurematsu et al.
5,179,398 A 1/1993 Iizuka

46 Claims, 13 Drawing Sheets

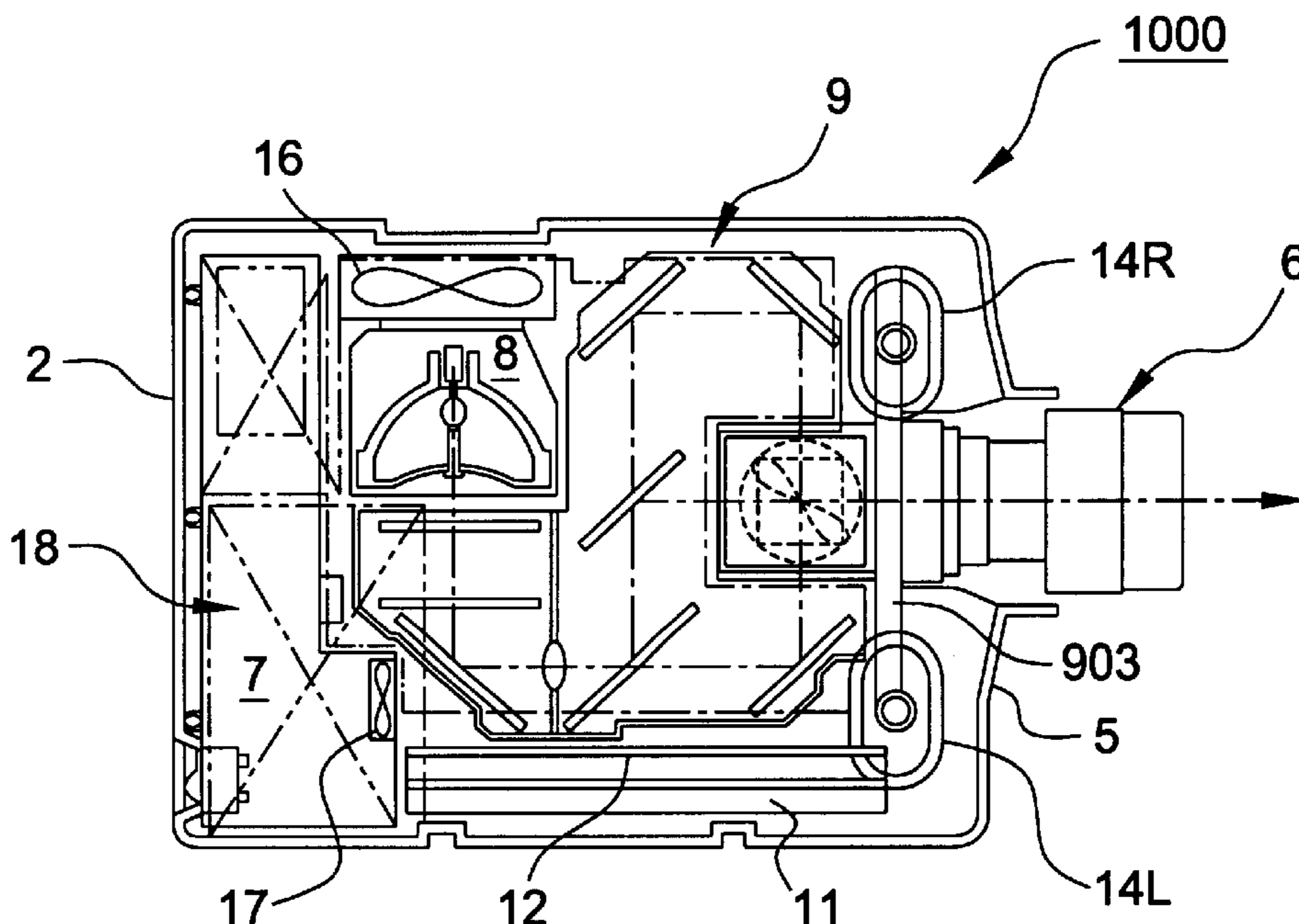

Fig. 1

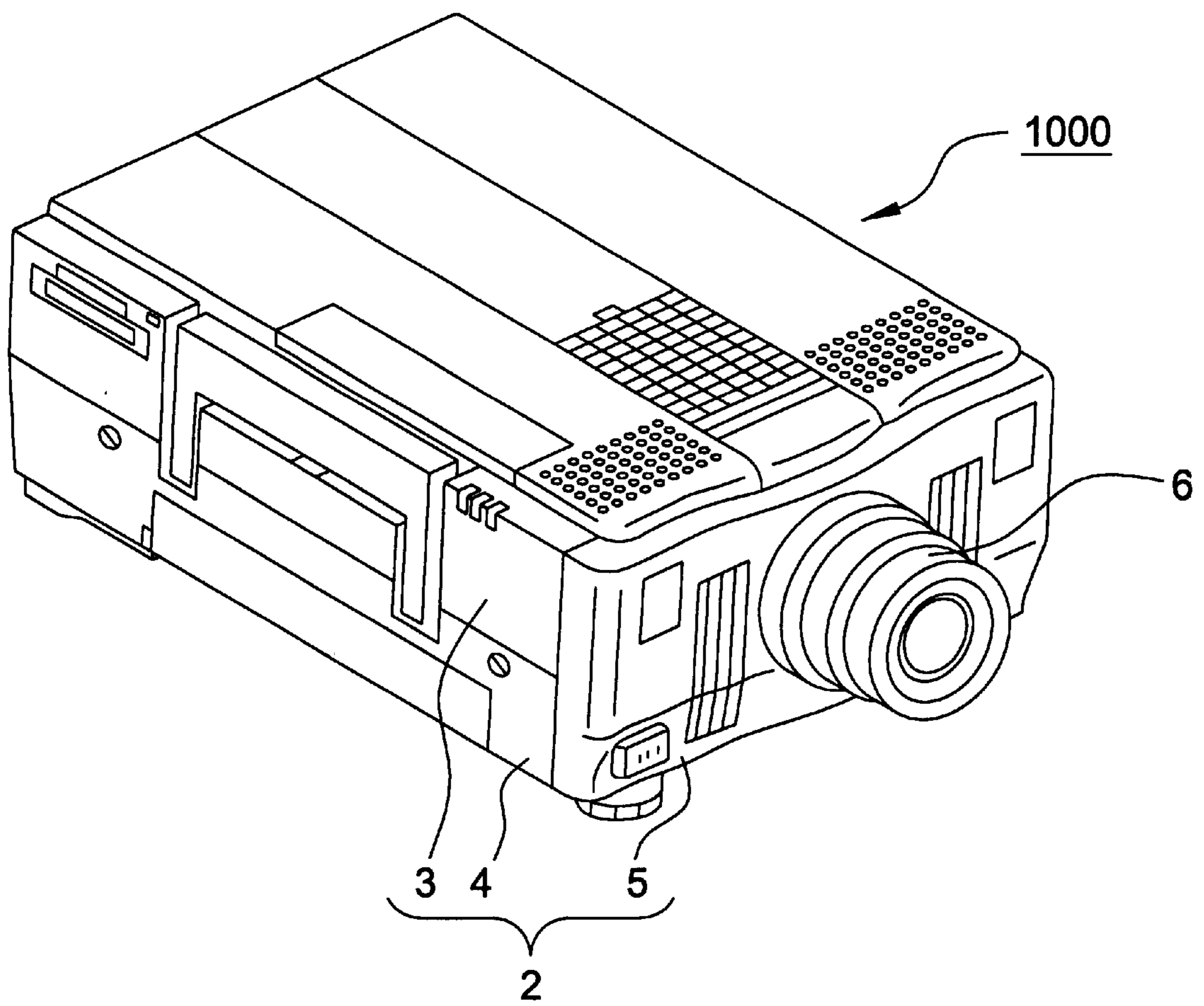

Fig. 2(A)

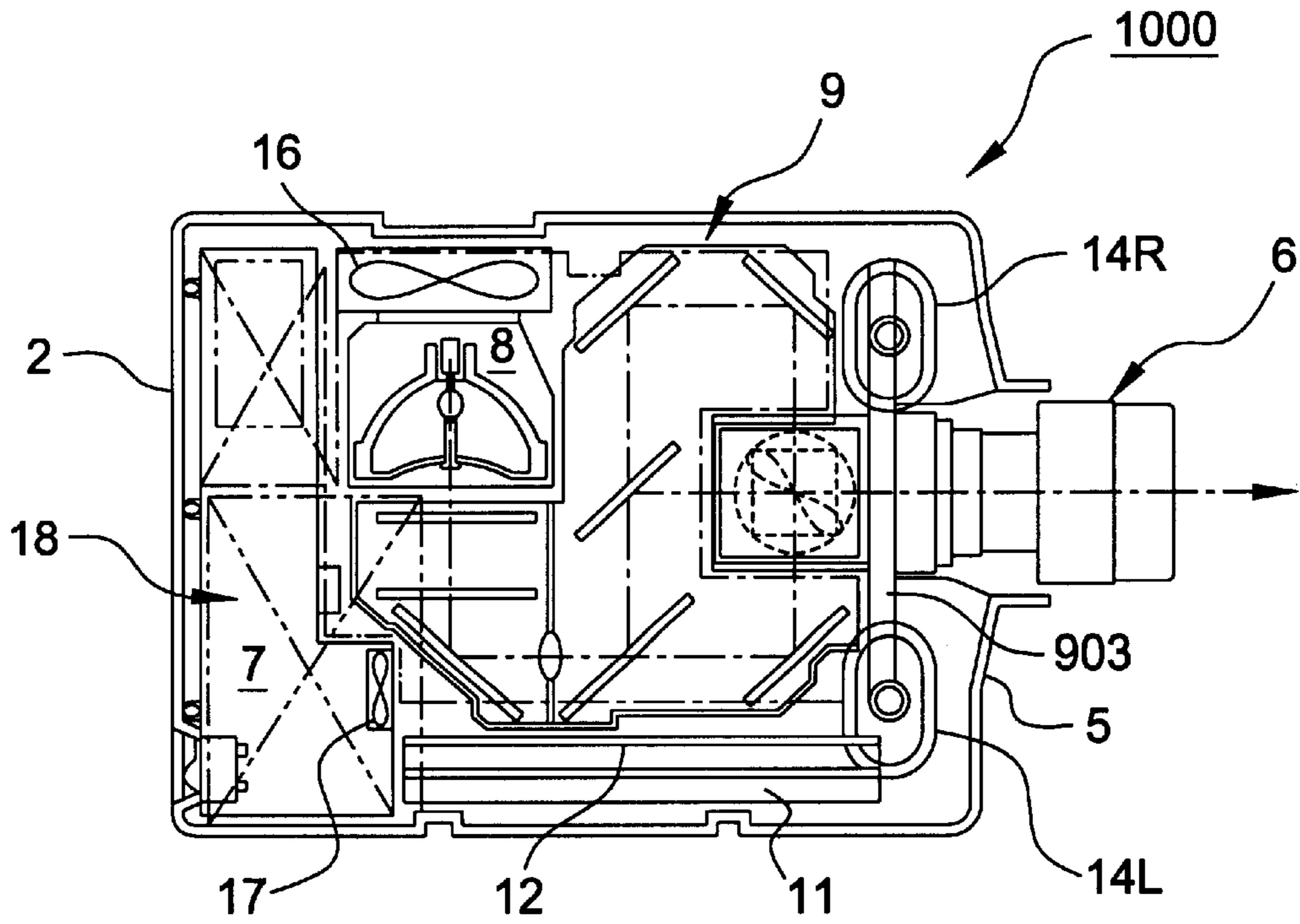

Fig. 2(B)

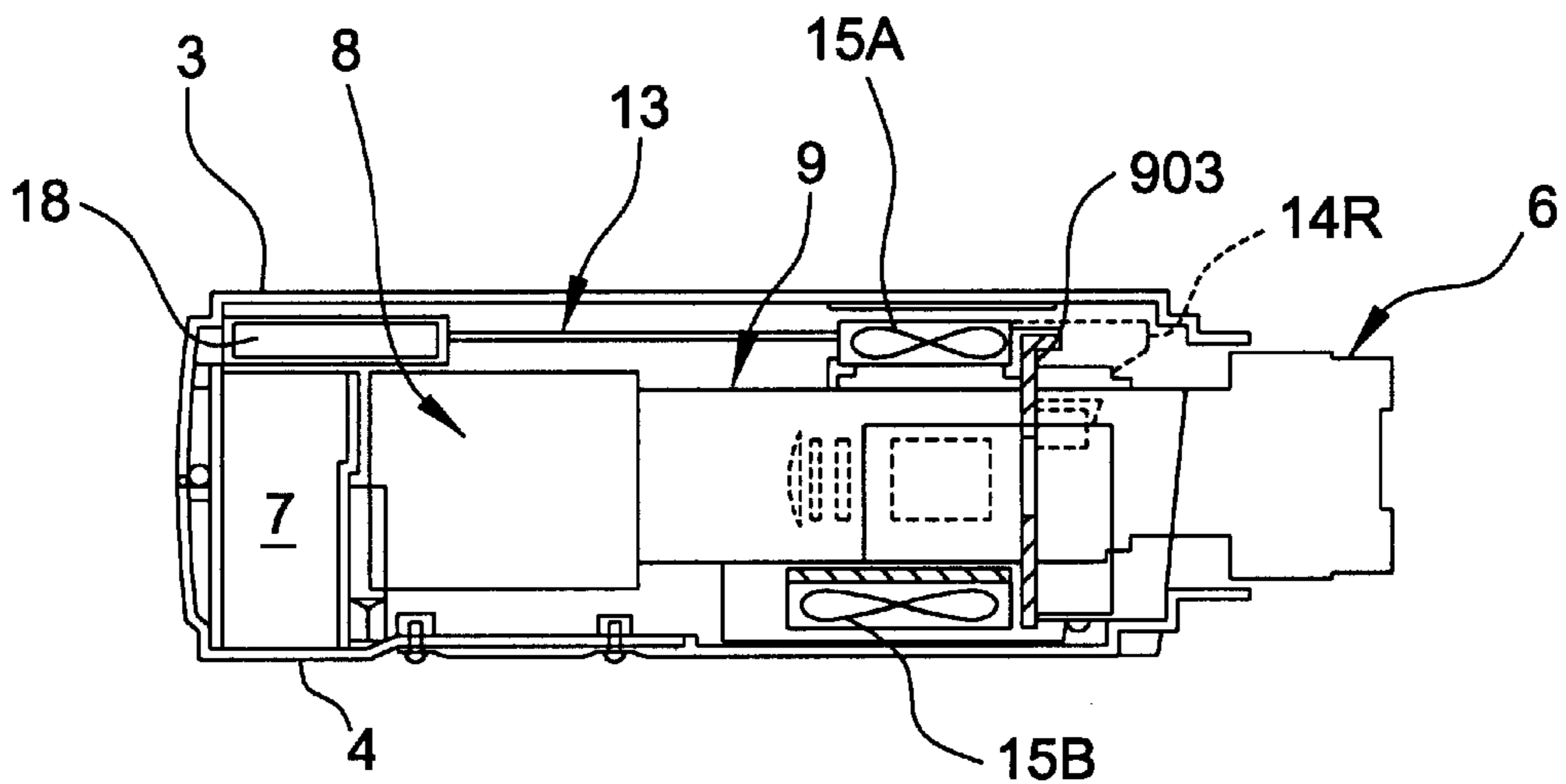

Fig. 3

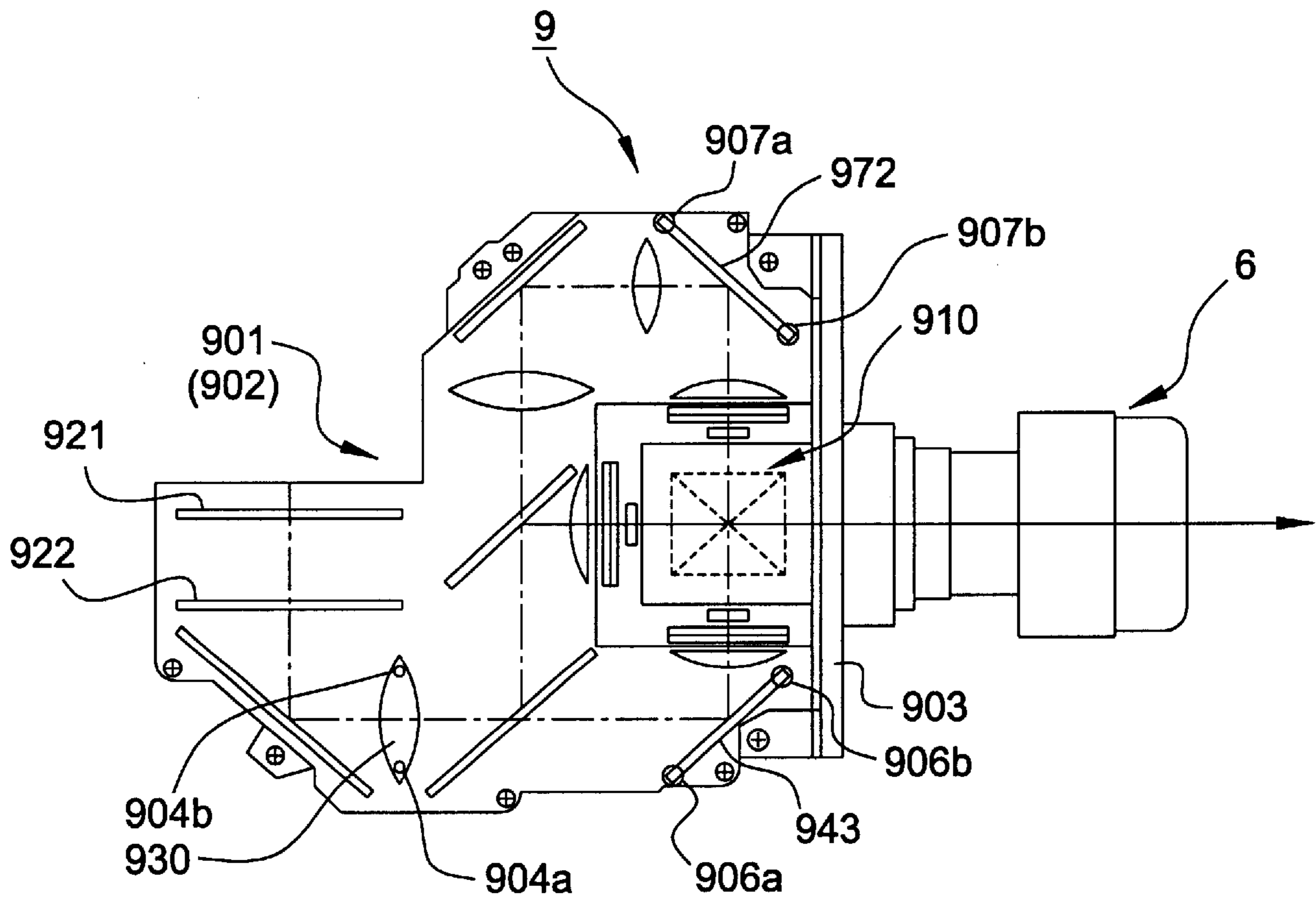

Fig. 4

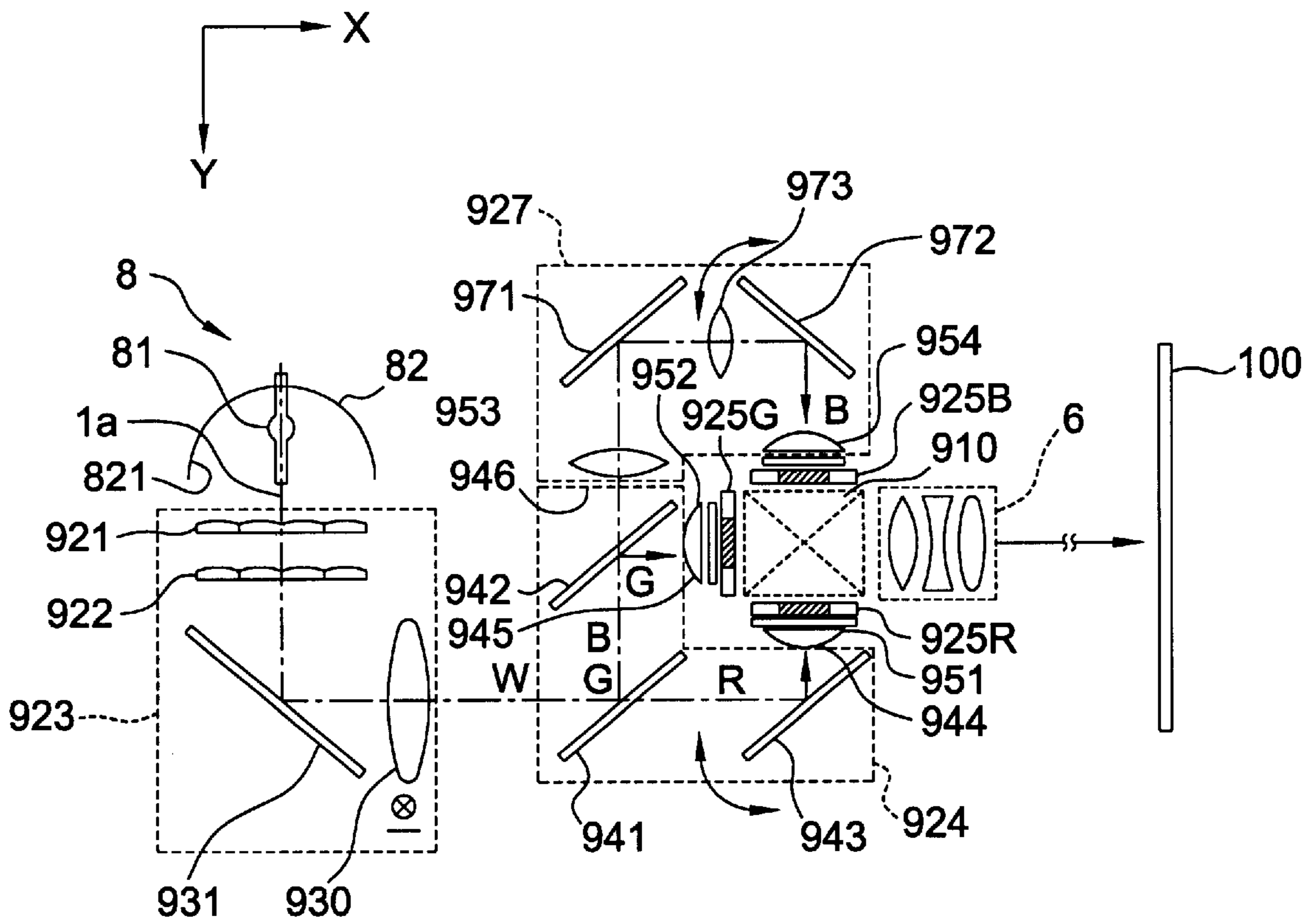

Fig. 5(A)

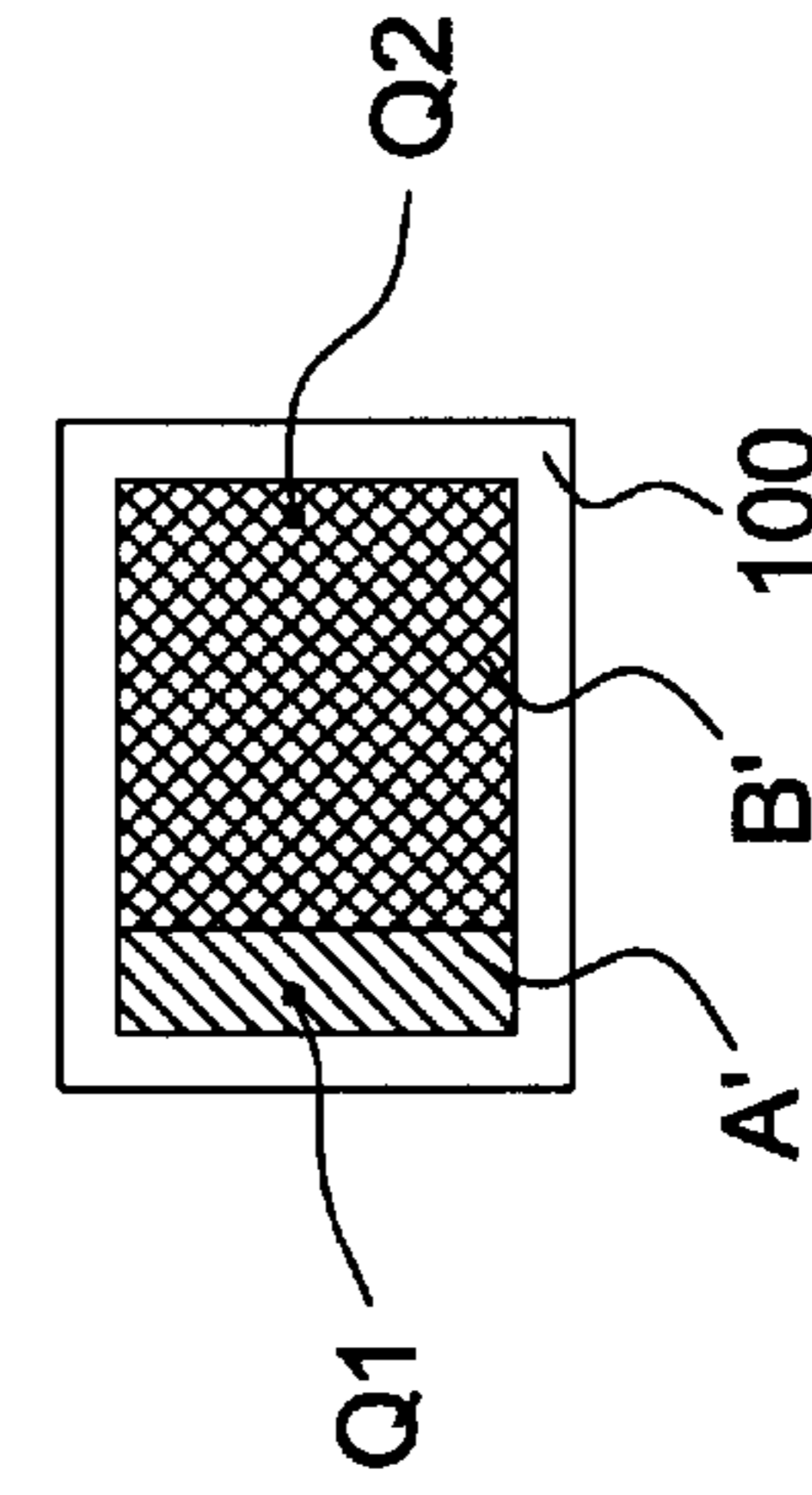
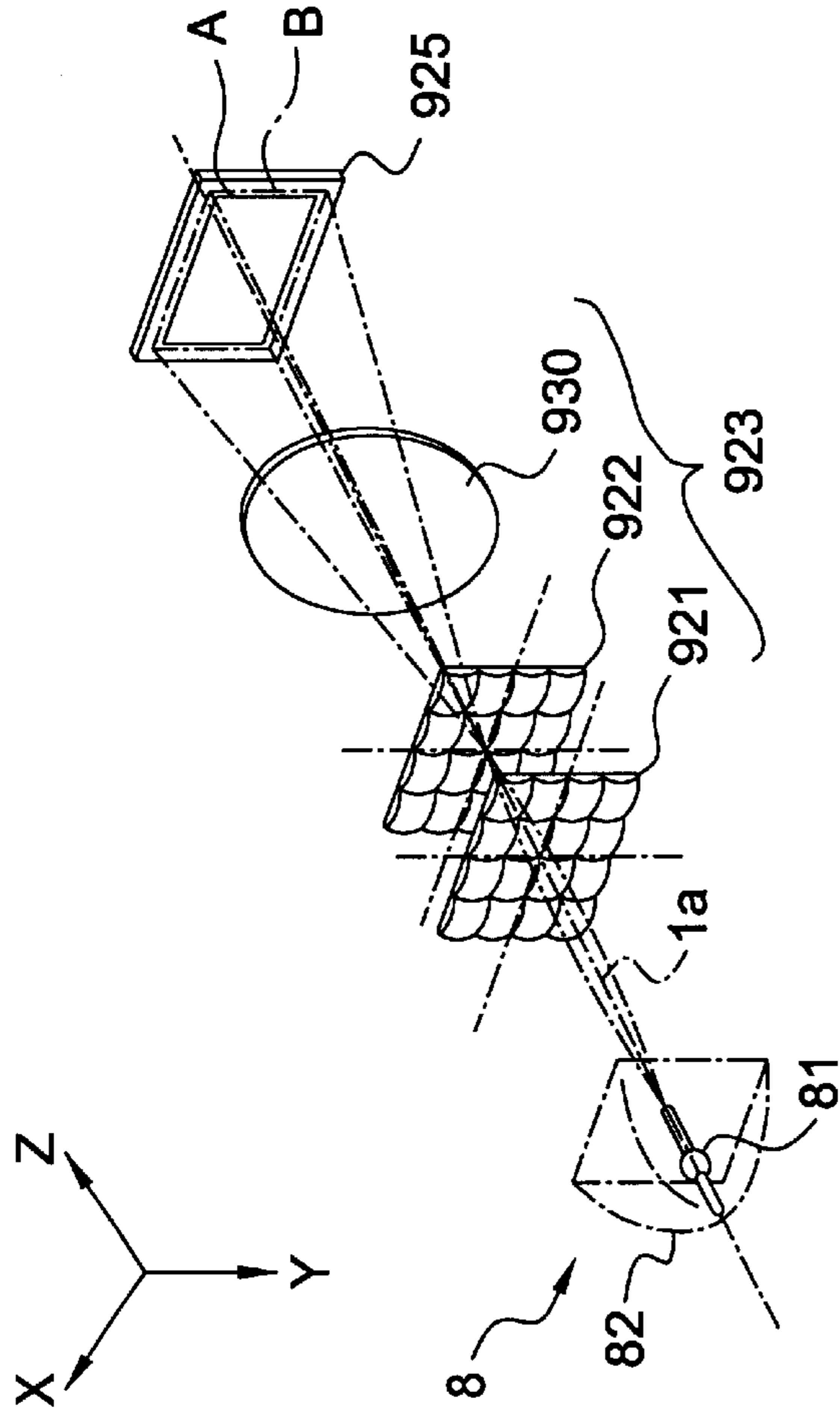

Fig. 5(D)

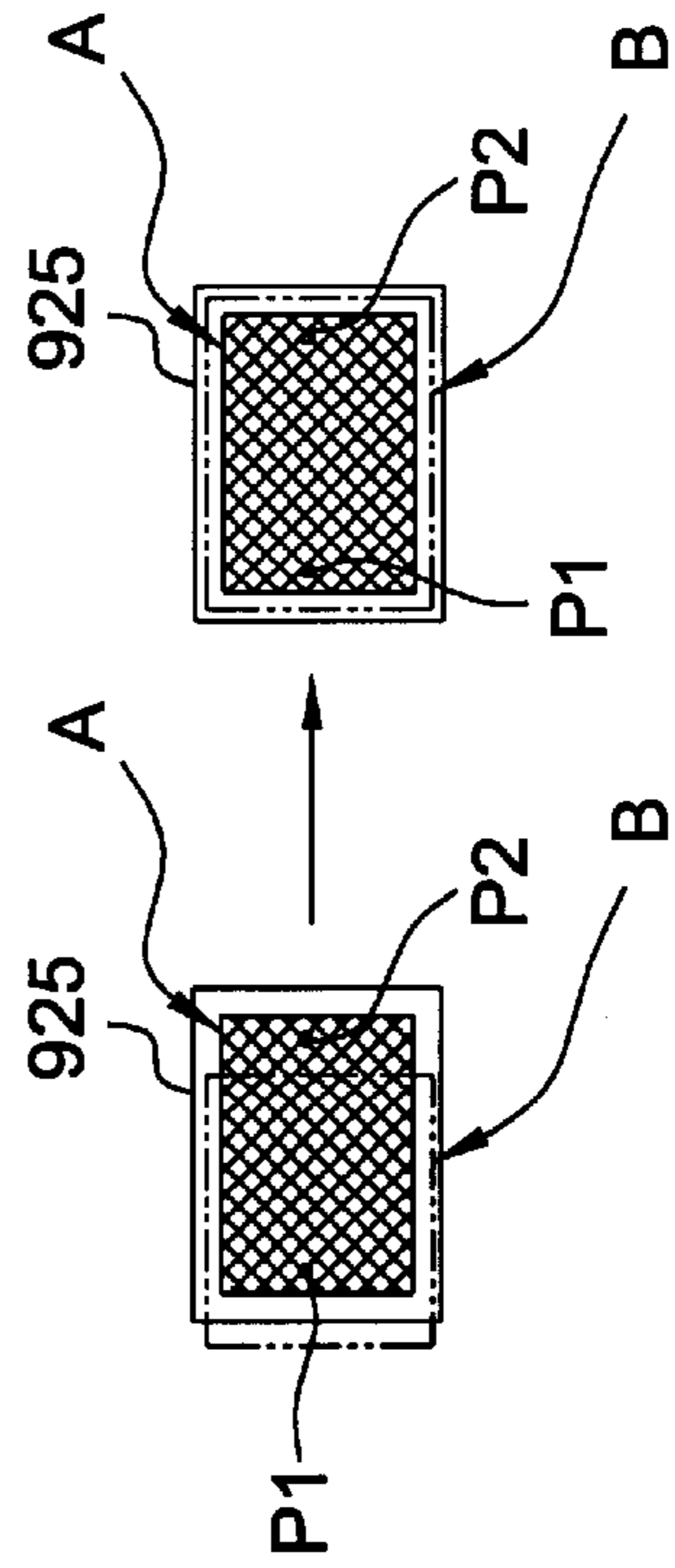

Fig. 5(C)

Fig. 5(B)

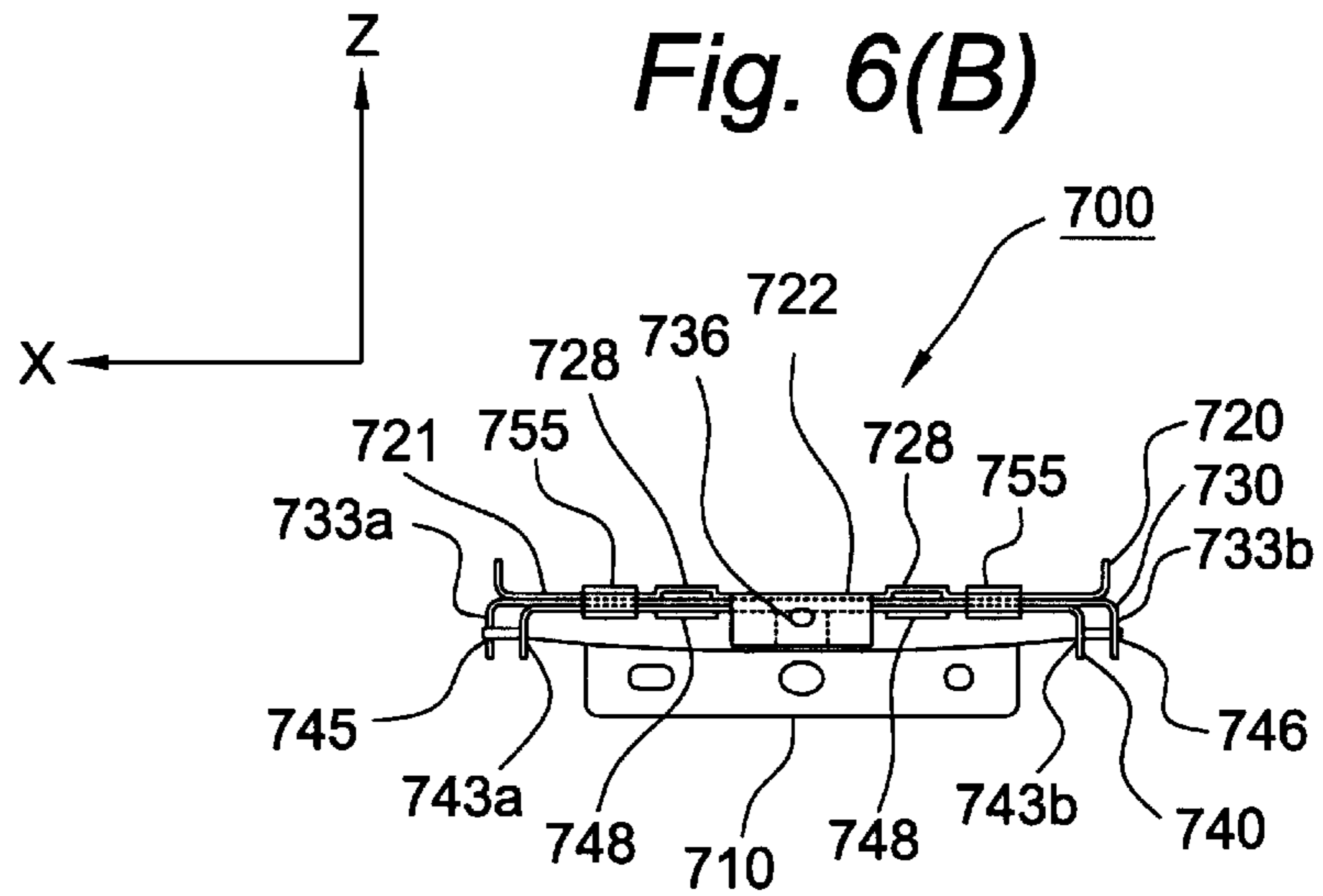

Fig. 6(B)

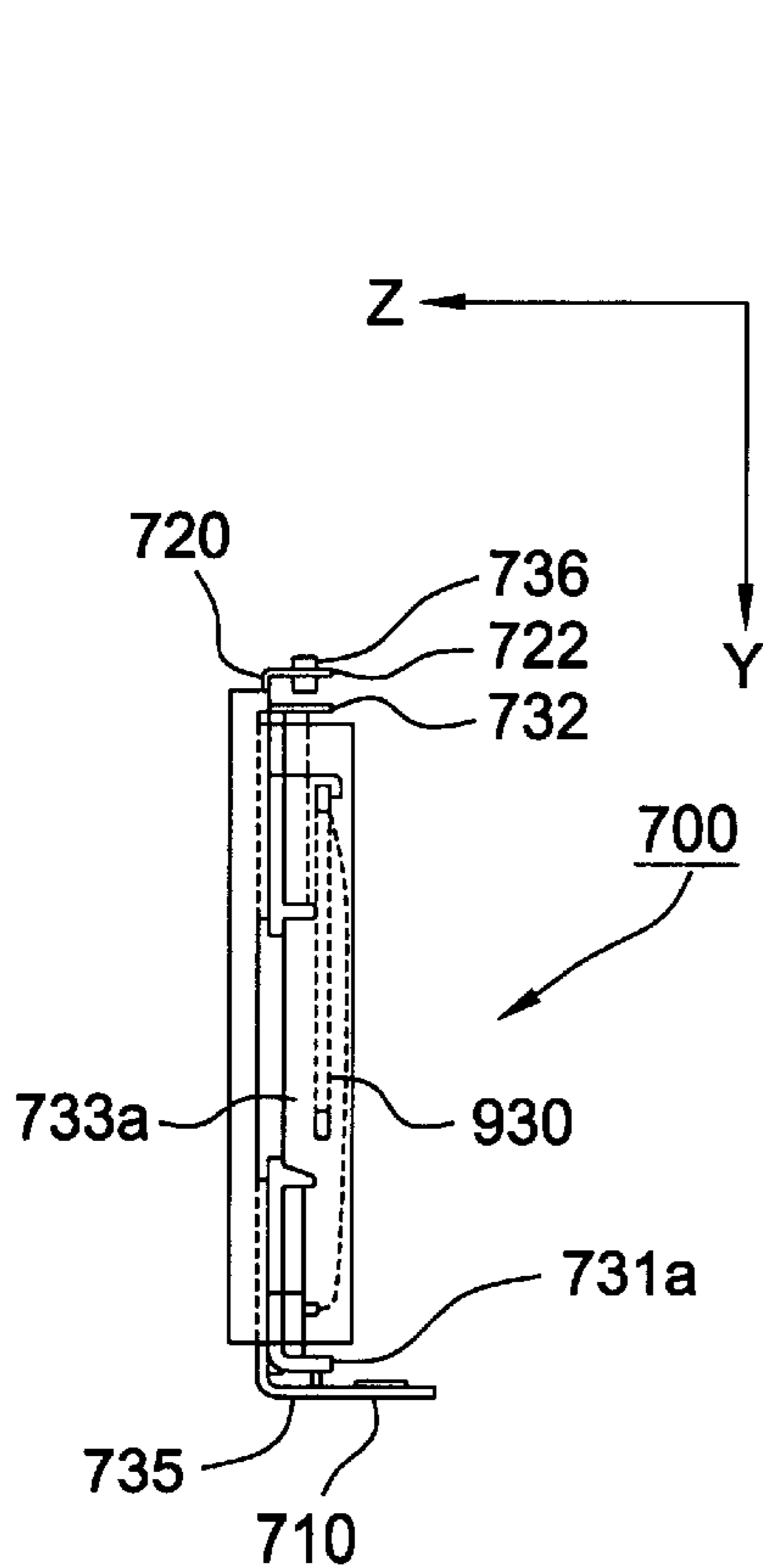

Fig. 6(C)

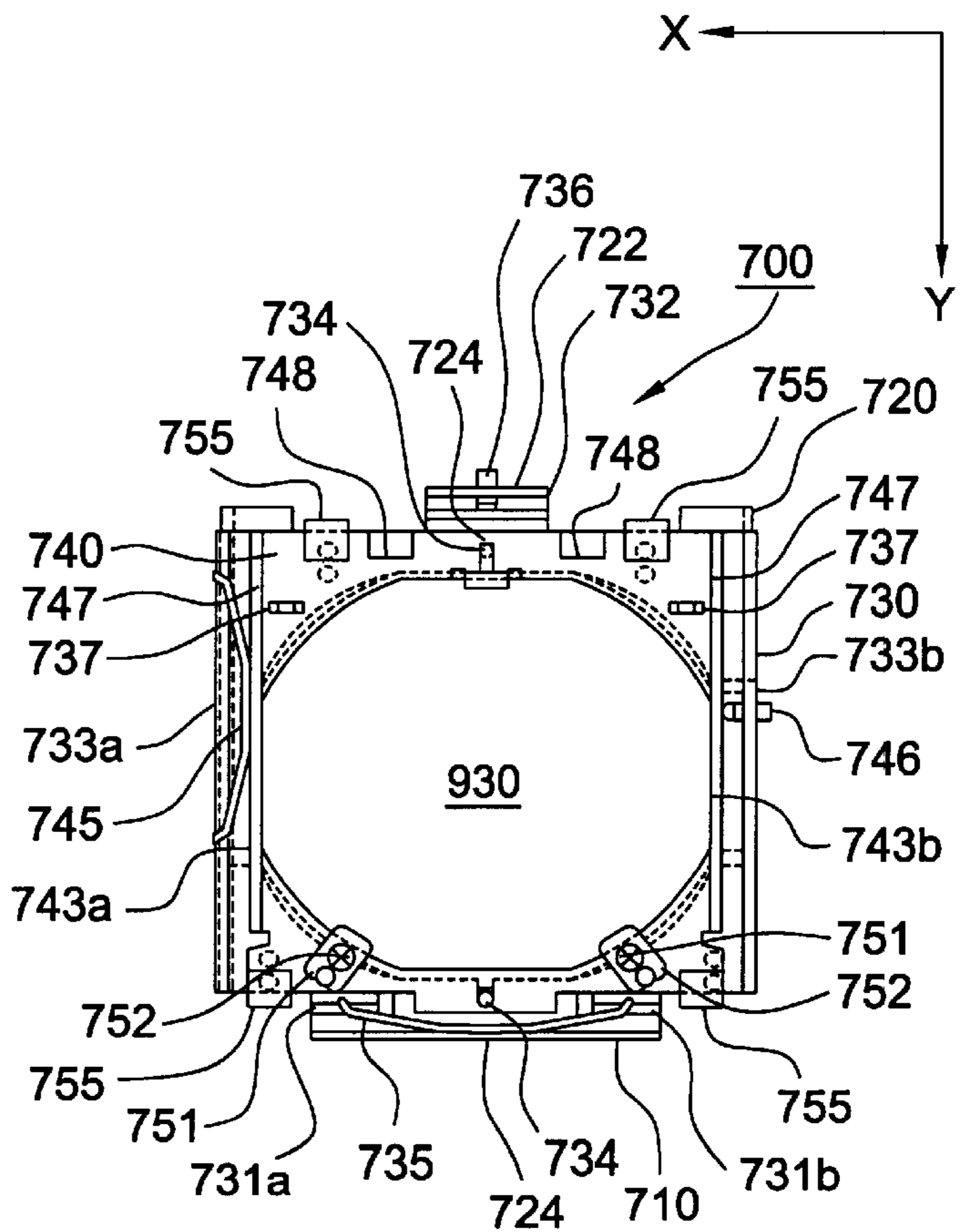
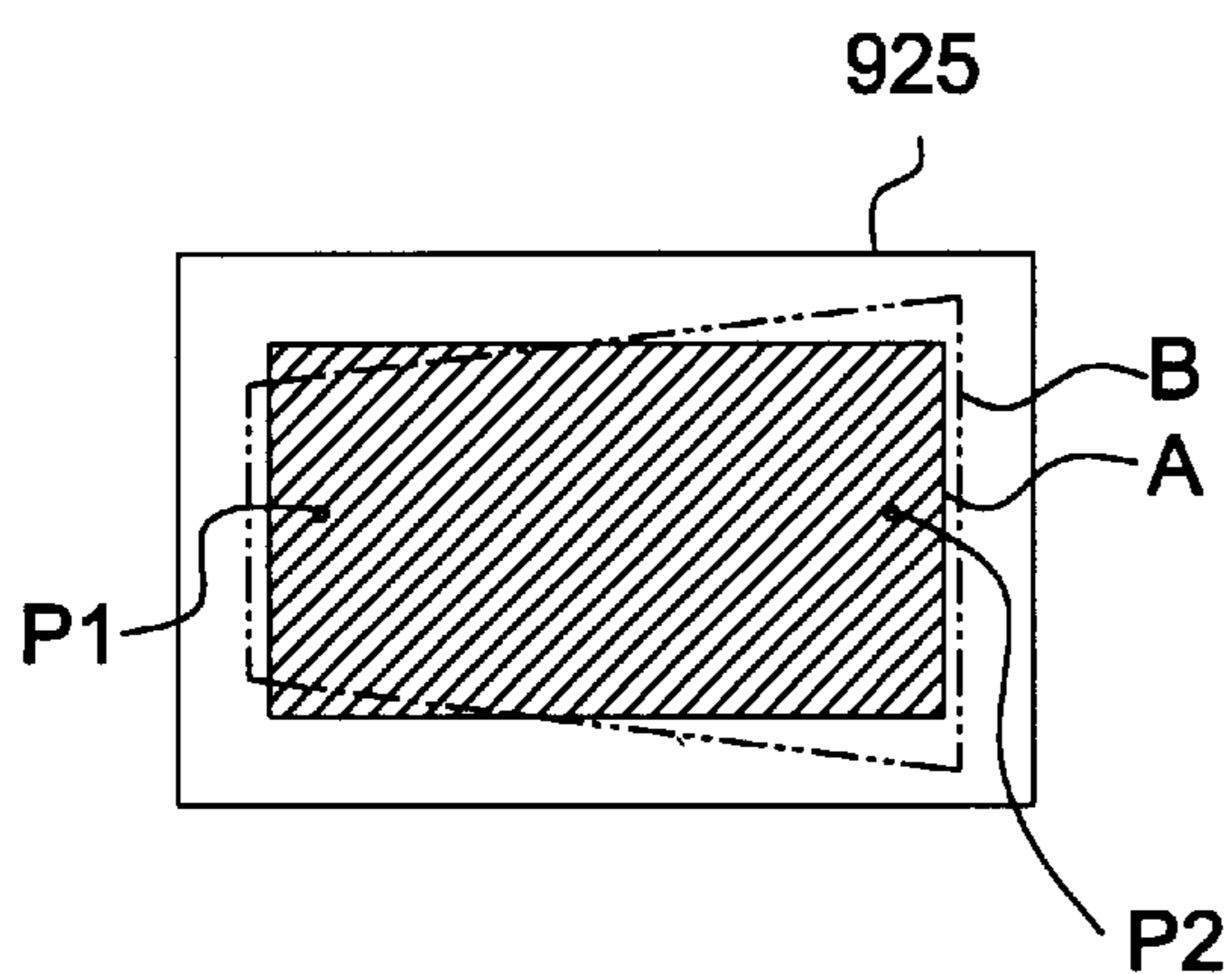
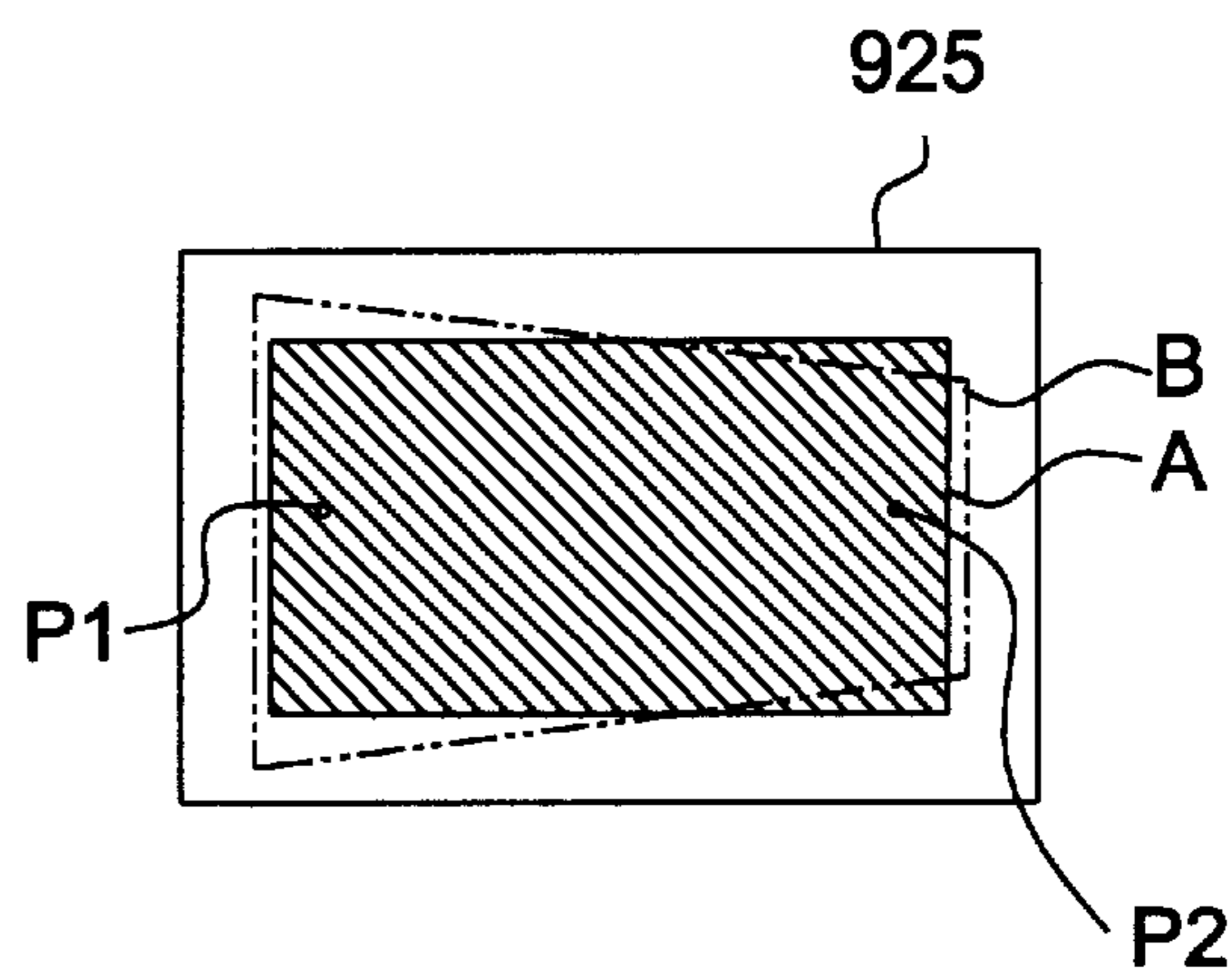

Fig. 6(A)



$P1 > P2$

Fig. 7(A)



$P1 < P2$

Fig. 7(B)

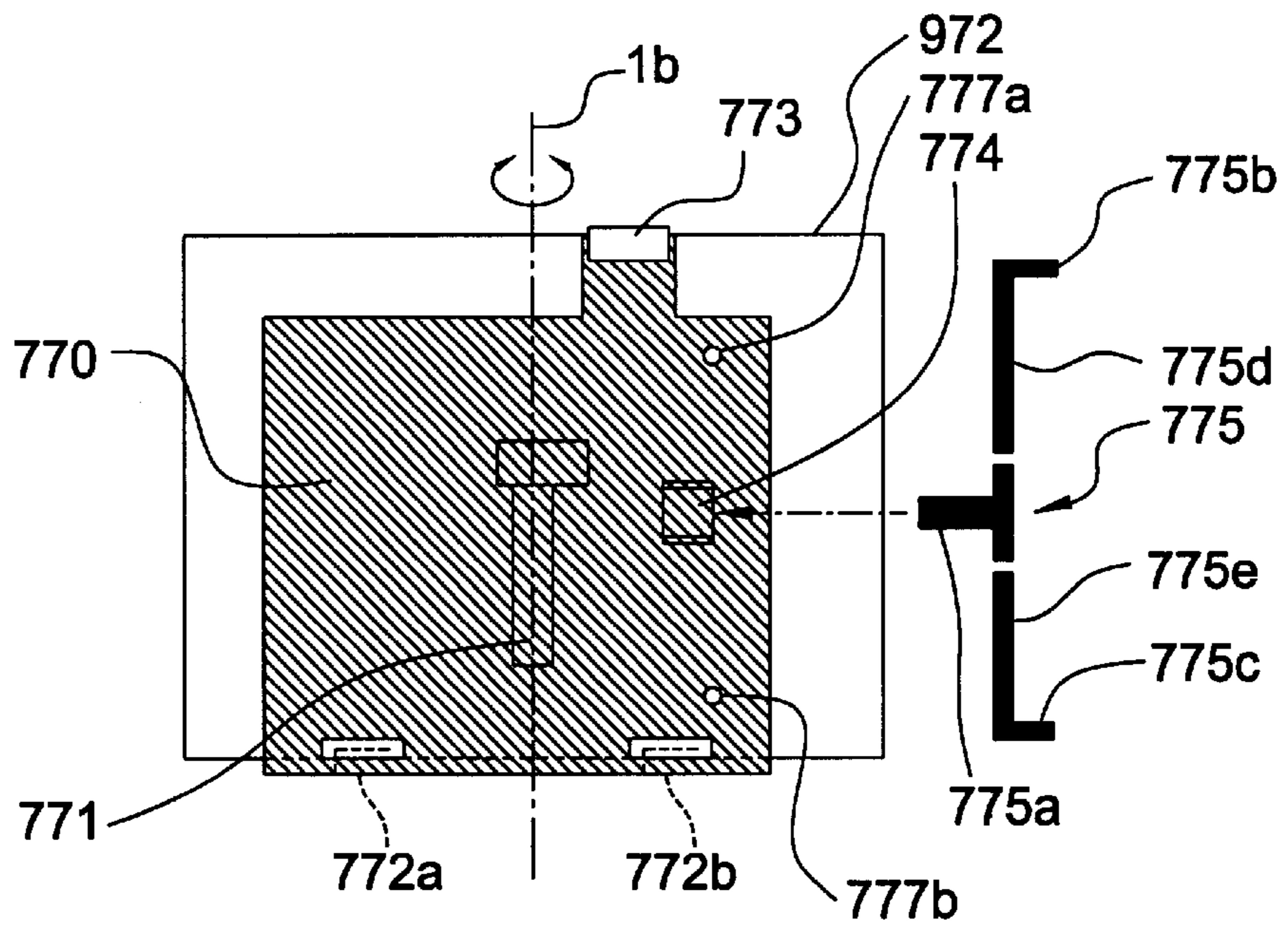

Fig. 8(A)

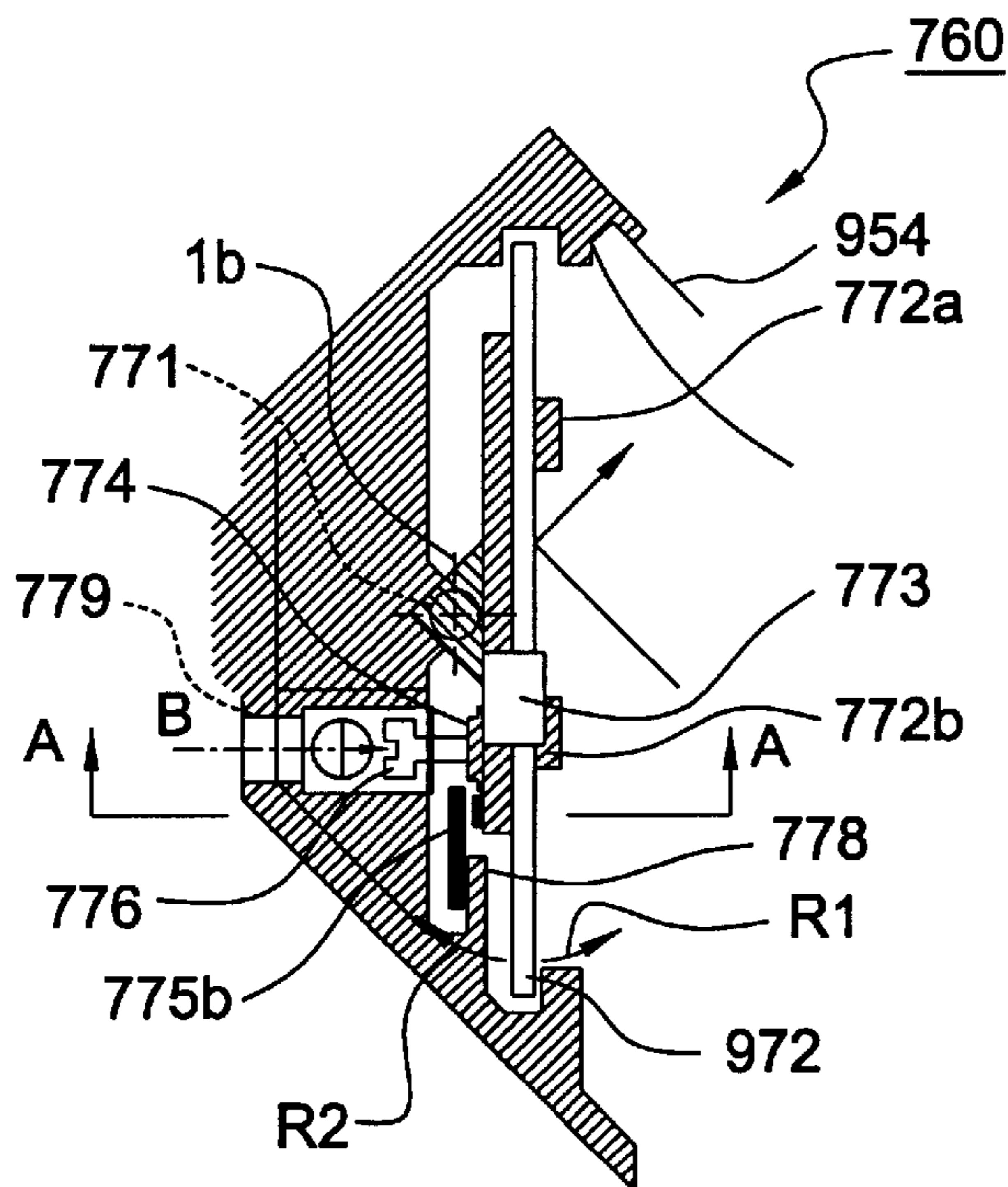

Fig. 8(B)

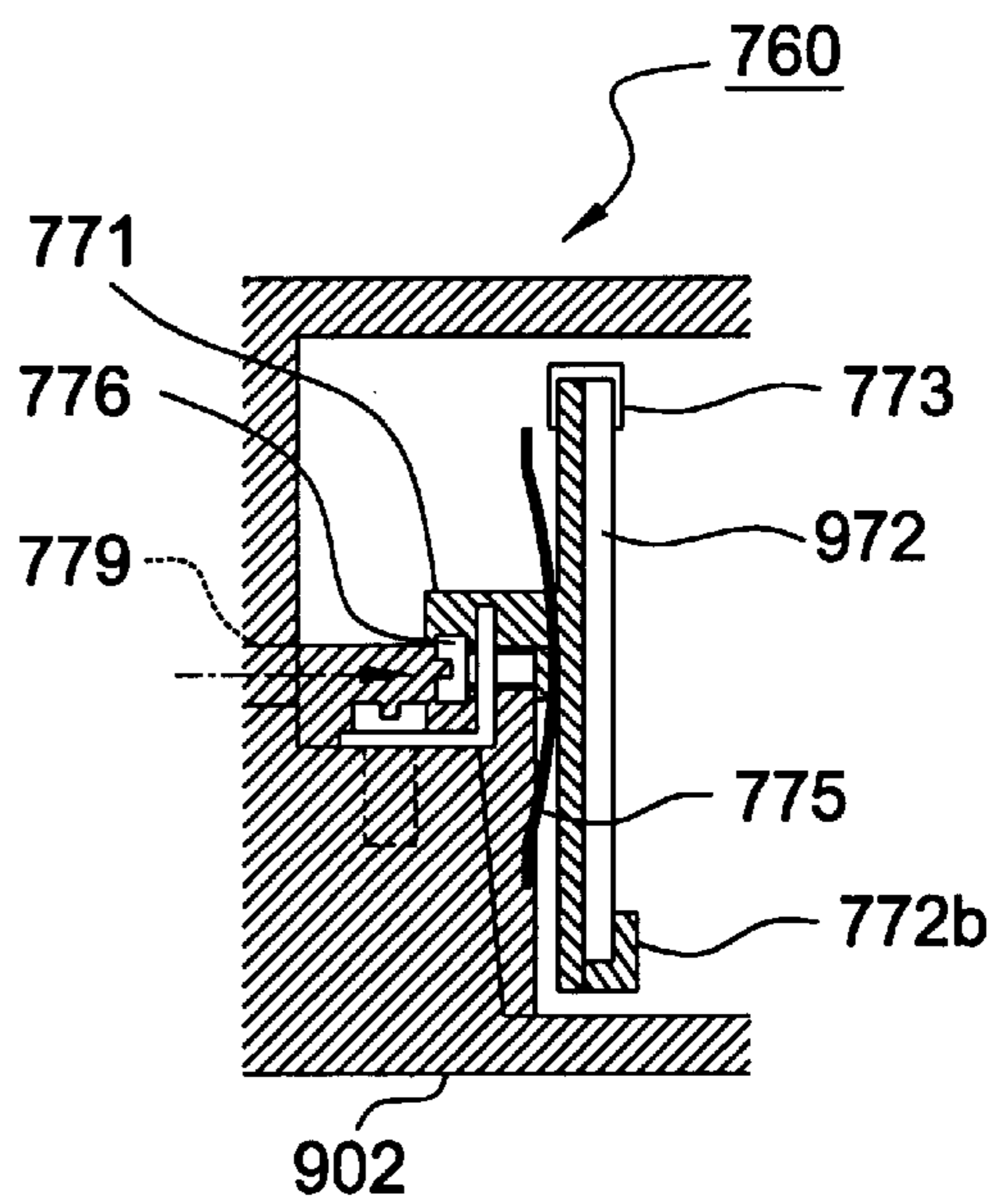

Fig. 8(C)

PROJECTION-TYPE DISPLAY APPARATUS

2000

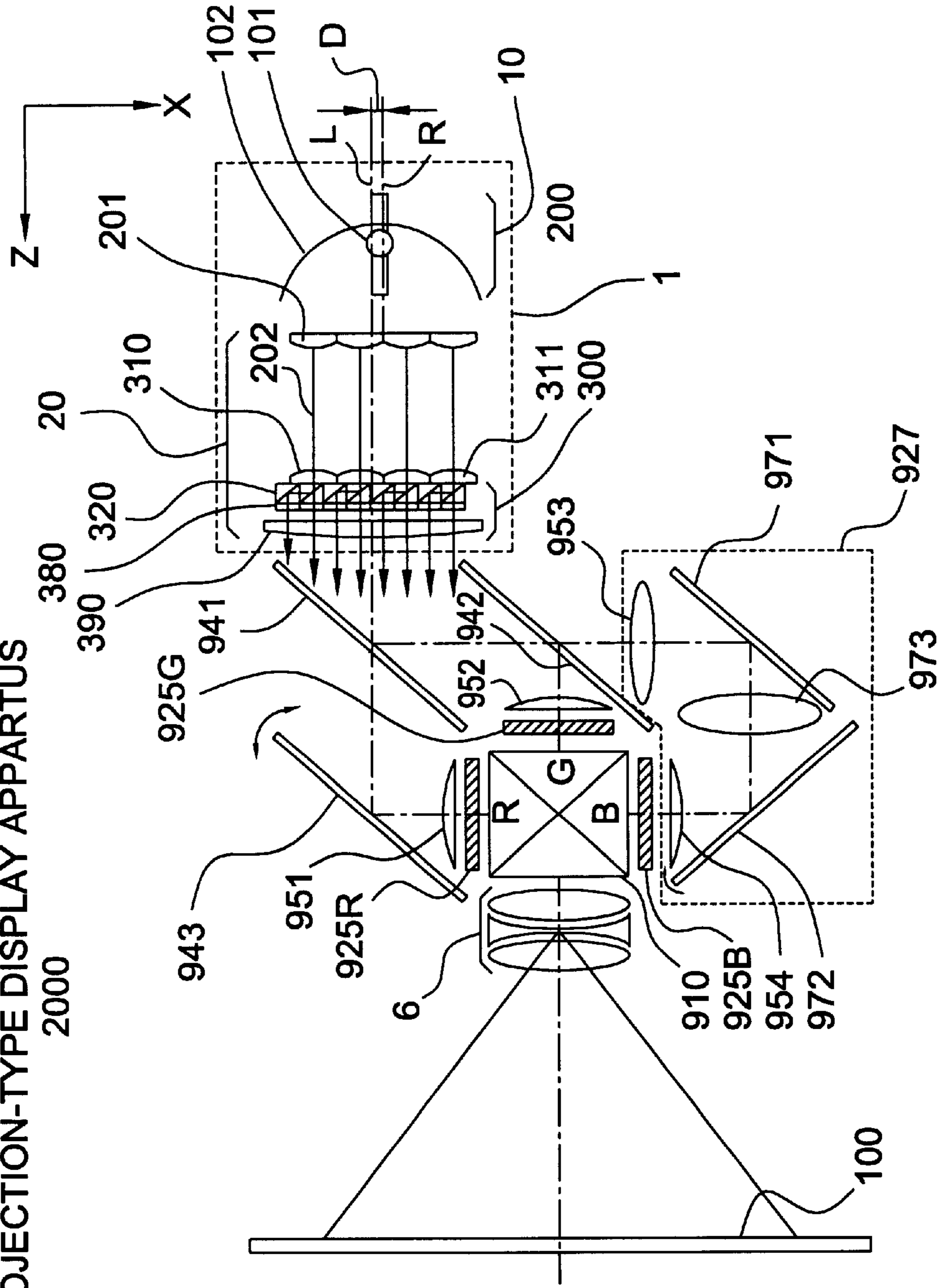

Fig. 9

Fig. 10(A)

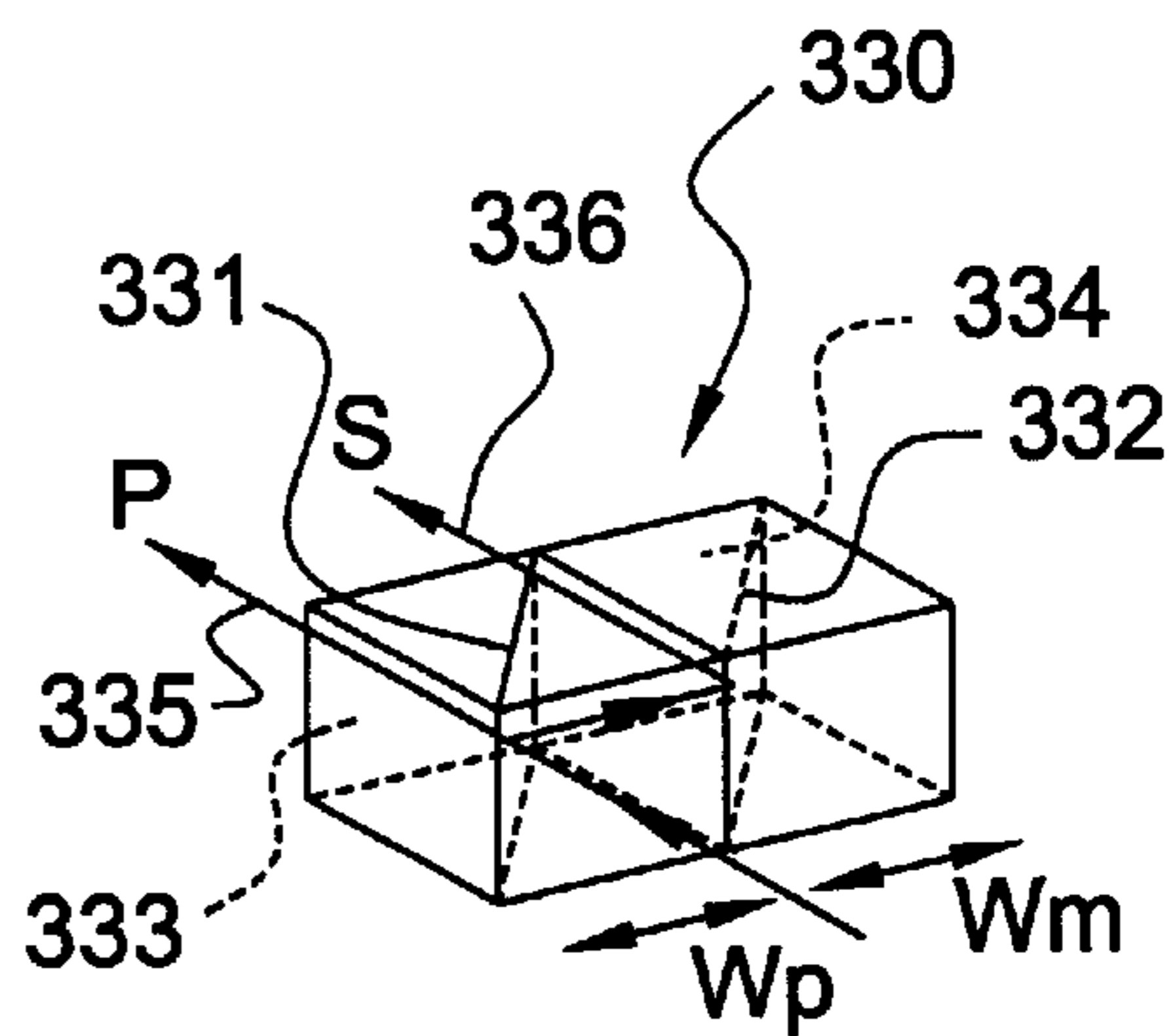
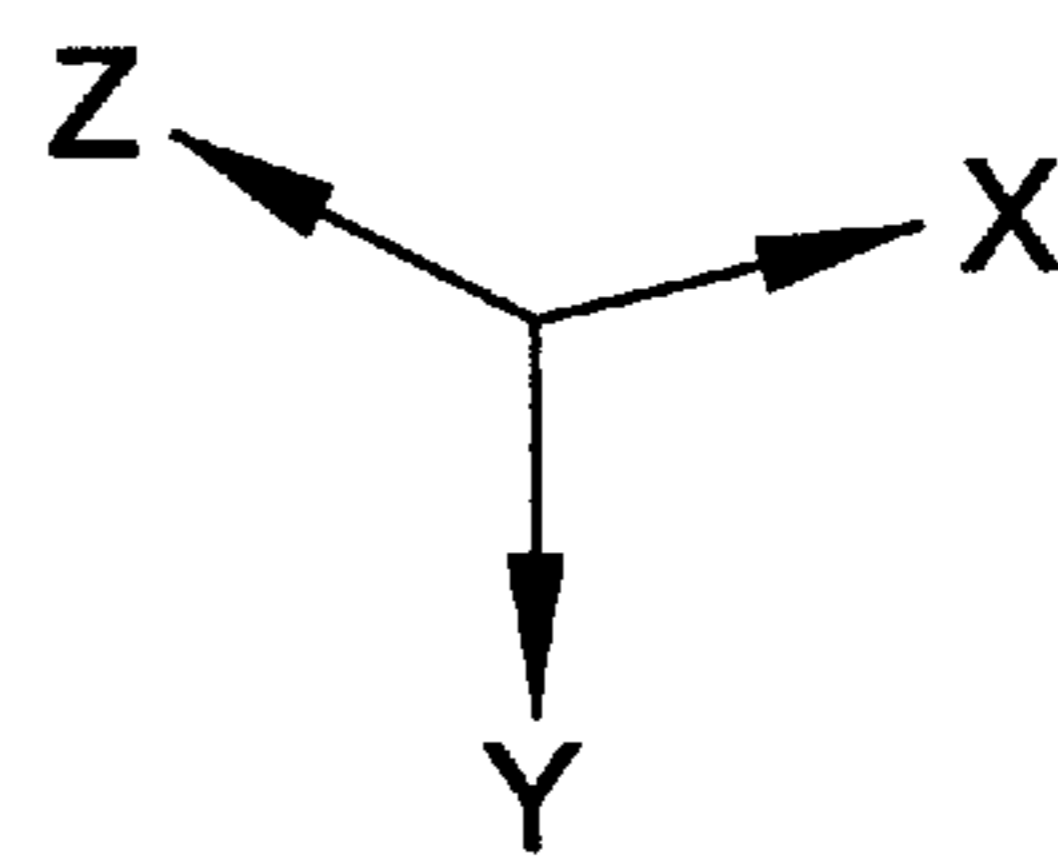
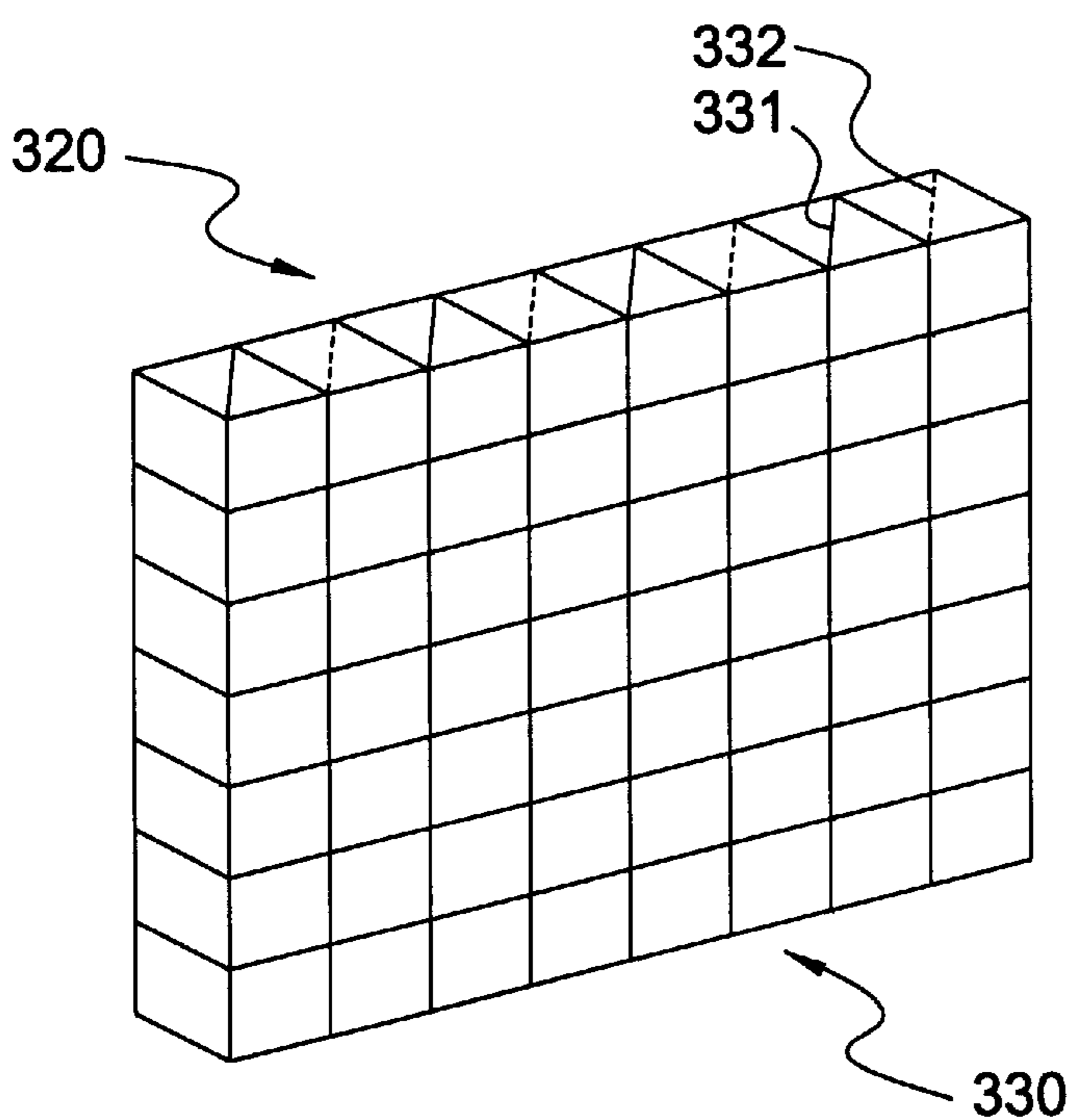

Fig. 10(B)

Fig. 11

PROJECTION-TYPE DISPLAY APPARATUS

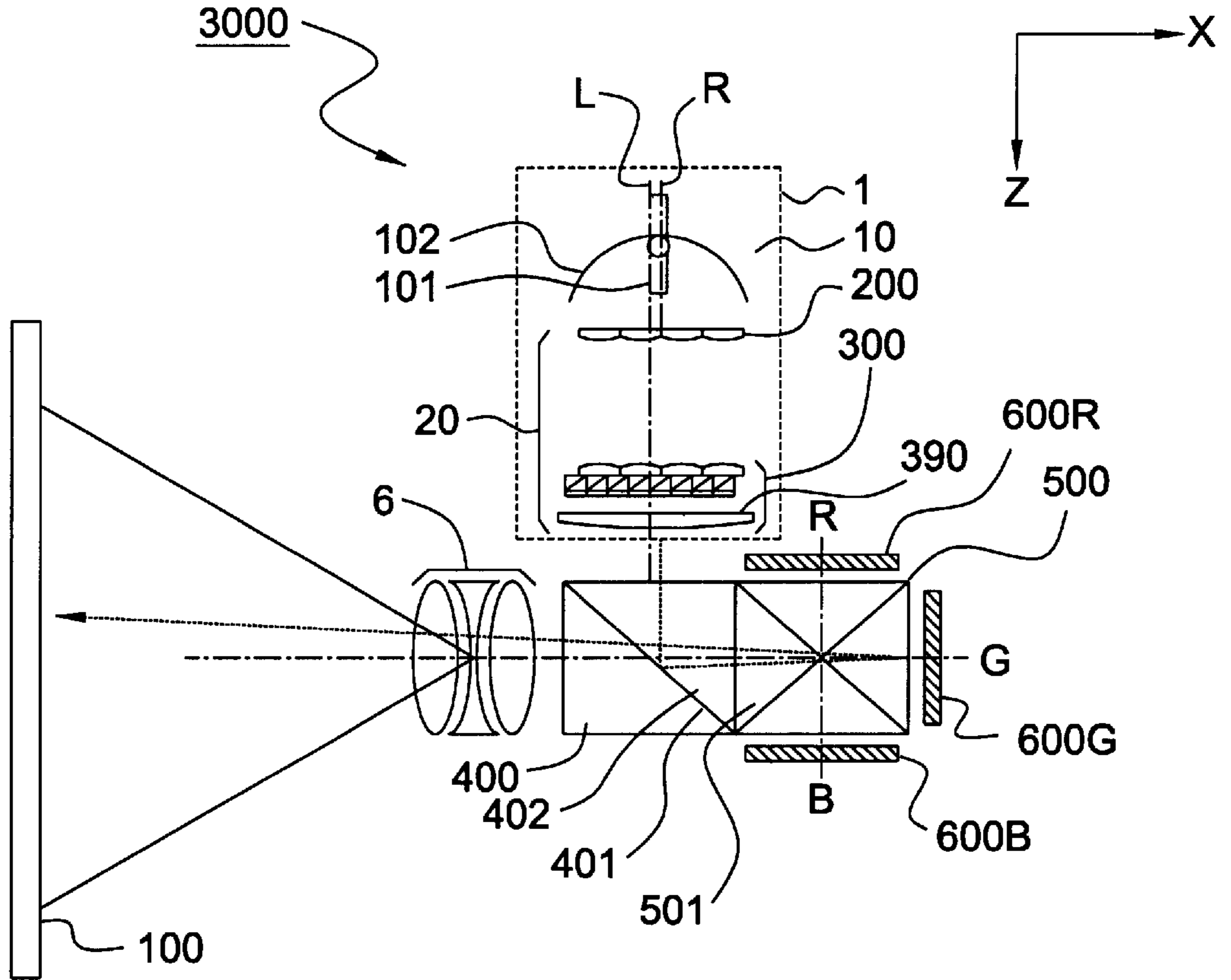

Fig. 12

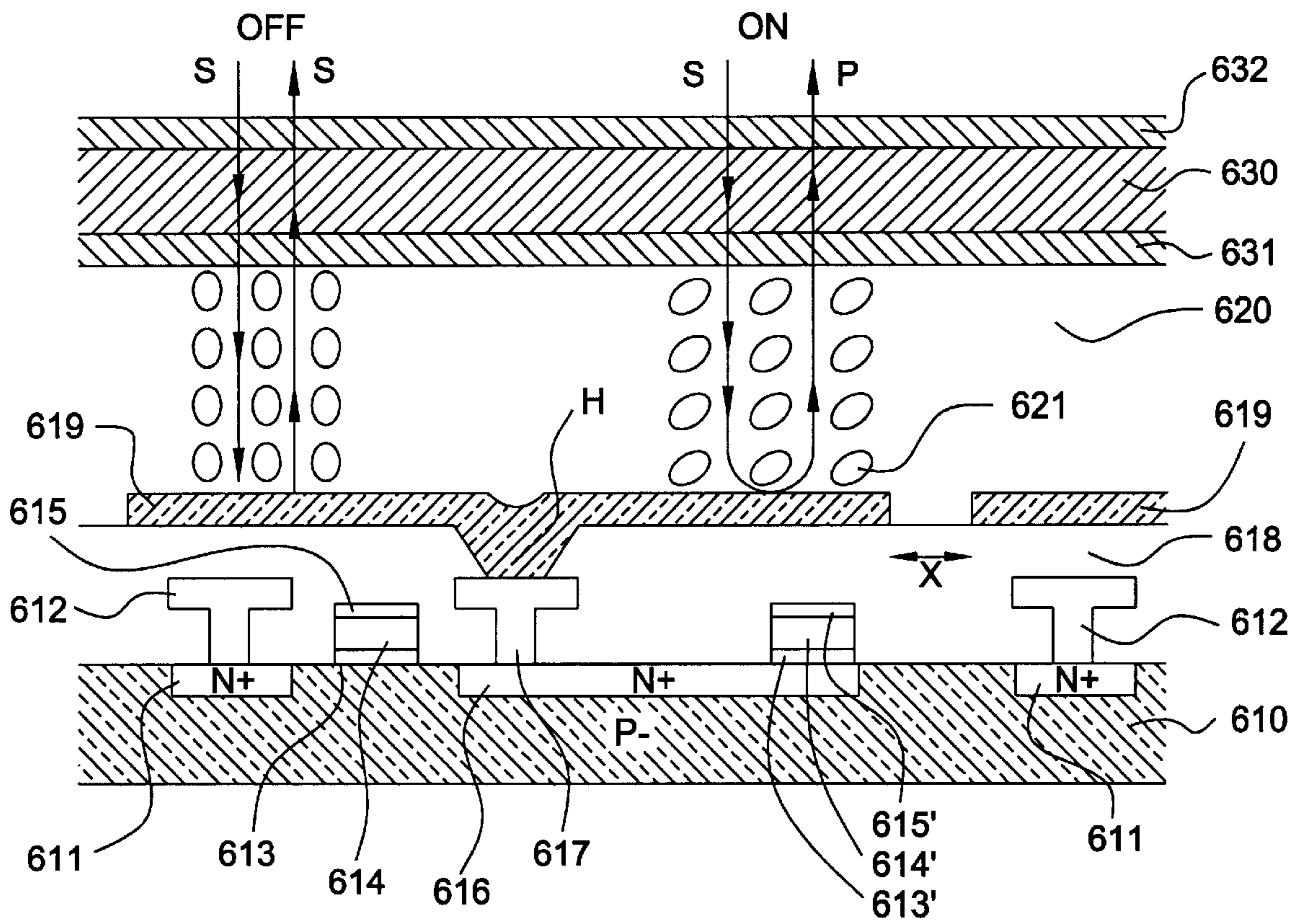

Fig. 13

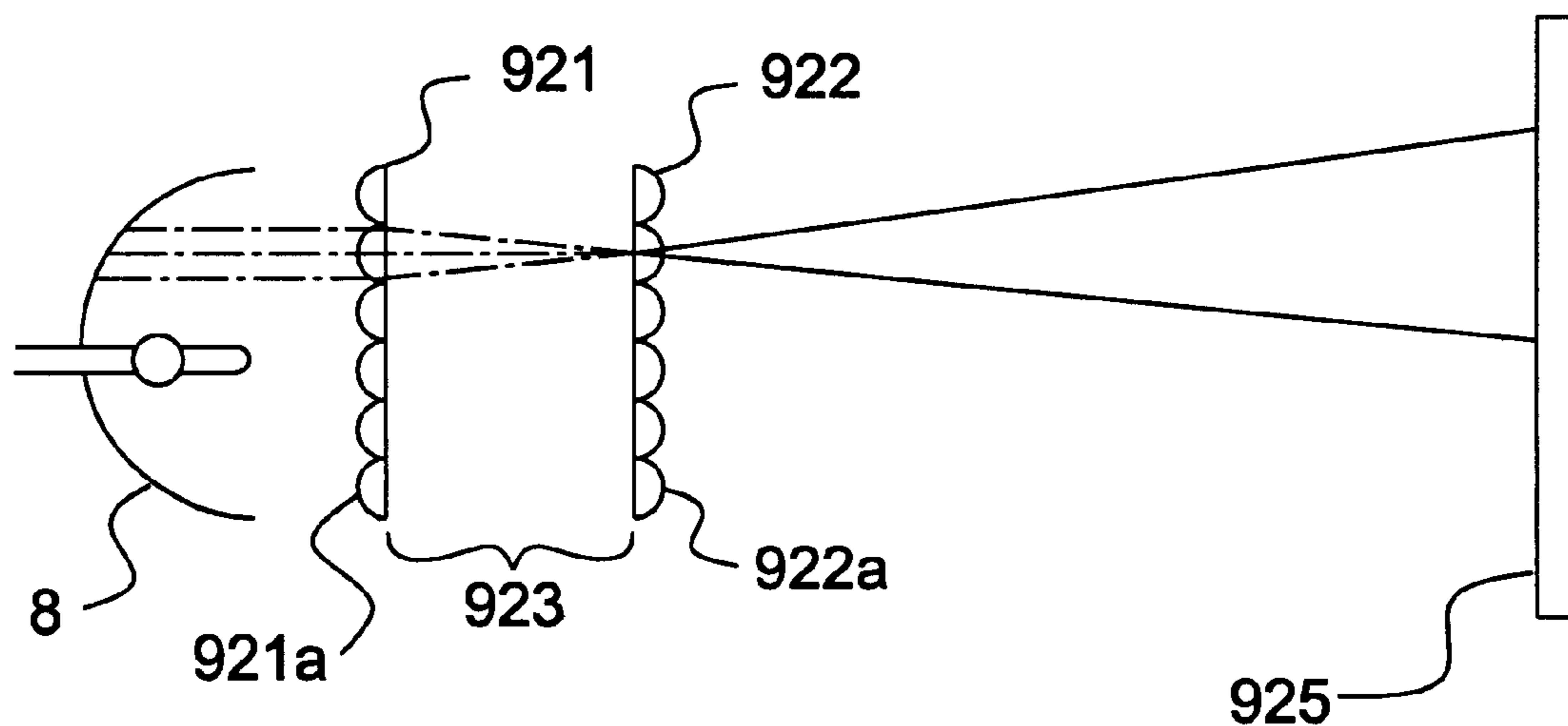
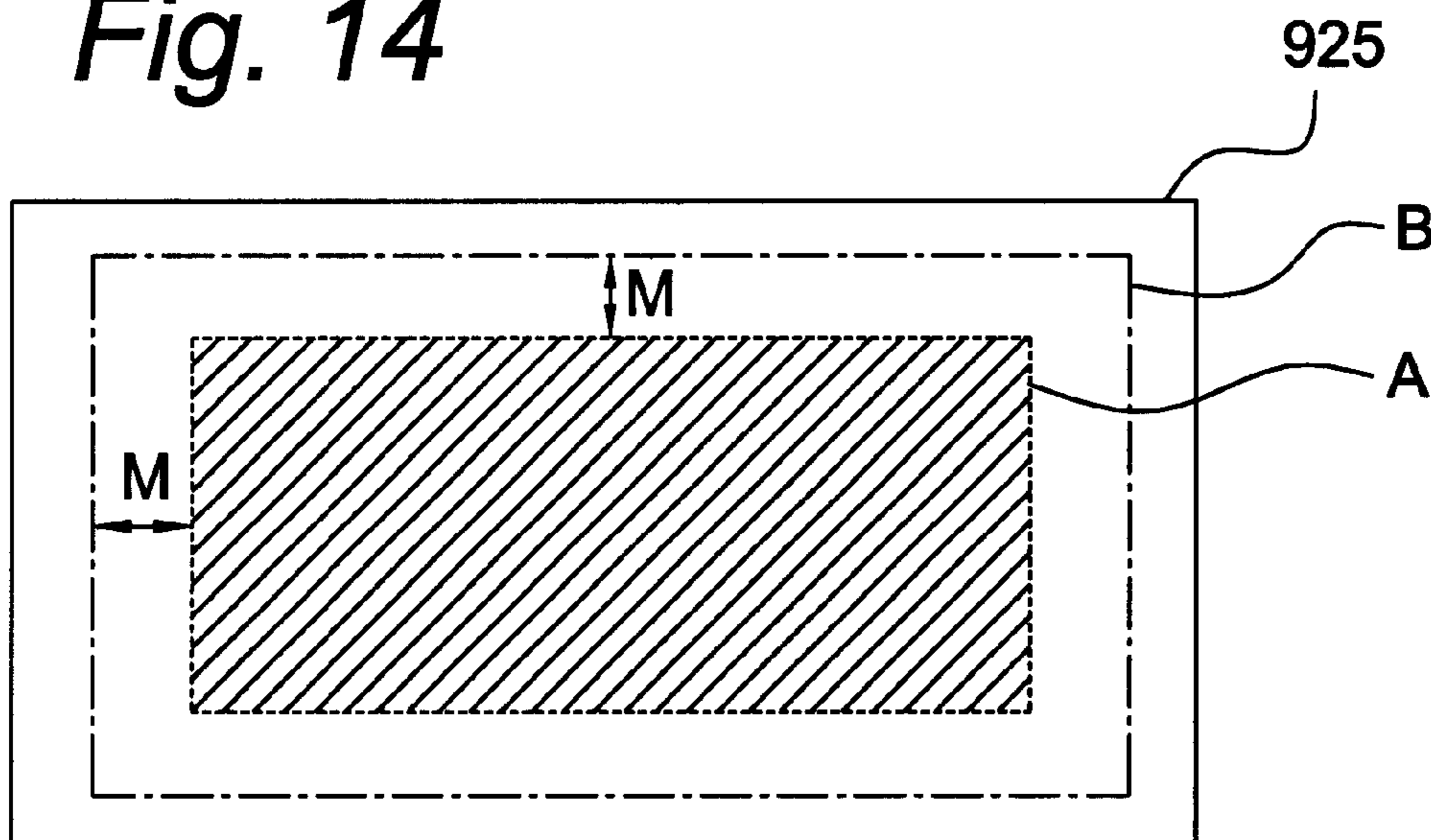

Fig. 14



1

PROJECTOR

Matter enclosed in heavy brackets [] appears in the original patent but forms no part of this reissue specification; matter printed in italics indicates the additions made by reissue.

BACKGROUND OF THE INVENTION

1. Field of Invention

The present invention relates to a projection-type display apparatus that modulates an output light beam from a light source in response to a video signal using a modulating device such as a liquid-crystal light valve or the like and enlarges and projects the modulated light beam through a projection lens onto a screen. More particularly, the present invention relates to a projection-type display apparatus that illuminates an image forming area of the modulating device such as a liquid-crystal light valve.

2. Description of Related Art

Japanese Unexamined Patent Publication 3-111806 discloses a projection-type display apparatus that forms a modulated light beam in response to a video signal using a liquid-crystal light valve and enlarges and projects the modulated light beam onto a screen. As shown in FIG. 13, the projection-type display apparatus includes an integrator optical system 923 having two lens plates 921 and 922, for uniformly illuminating the image forming area of a liquid-crystal valve 925, as a modulating device, with light from a light source.

The single light beam emitted from a light source lamp unit 8 is split into a plurality of intermediate light beams by lenses 921a constituting the first lens plate 921, and is superimposed on the liquid-crystal light valve 925 through lenses 922a constituting the second lens plate 922.

In this projection-type display apparatus, the brightness of an image projected onto the screen will drop or the projected image suffers an outlining shadow if the image forming area of the liquid-crystal light valve 925 is not accurately illuminated. To cope with this problem, as shown in FIG. 14, a certain margin M is assured around the image forming area A of the liquid-crystal light valve 925 in view of the positioning accuracies of the liquid-crystal light valve 925 and the lens plates 921, 922 constituting the integrator optical system 923, the positional errors in the focal points of the lenses 921a, 922a of the lens plates and the positioning accuracies of the remaining optical systems disposed along the optical axis.

More particularly, the image forming area A is sized to be distinctly smaller than an illumination area B by the output light from the light source. Even if the illumination area B is offset vertically upward or downward, or horizontally leftward or rightward depending on the overall positioning accuracy of the above components, the image forming area A is designed to be kept within the illumination area B. This avoids the outlining shadow around the projected image and drop in brightness of the projected image. To cope with a large quantity of positional error of the components, the margin M is simply widened.

To increase the brightness of a projected image, the efficiency in the utilization of the light that illuminates the liquid-crystal light valve 925 needs to be increased. If the margin M is enlarged to accommodate errors of the components, the efficiency in the utilization of light drops, thereby dimming the projected image. Thus, the width of the margin formed around the image forming area of the liquid-

2

crystal light valve is preferably narrow. A narrow margin in turn offsets the illumination area from the image forming area of the liquid-crystal light valve, possibly presenting a shadow outlining the projected image.

SUMMARY OF THE INVENTION

It is an object of the present invention to provide a projection-type display apparatus that offers an increased image brightness without any shadow around a projected image while presenting a narrow margin around the image forming area of a liquid-crystal light valve.

A first projection-type display apparatus of the present invention may include a light source, a modulating device for modulating a light beam emitted by the light source and a projection device for enlarging and projecting the modulated light beam from the modulating device onto a projection area. An optical element may be disposed in an optical path between the light source. The modulating device may split the light beam emitted from the light source into a plurality of intermediate light beams. A superimposing device may also be provided for superimposing each of the slit intermediate light beams from the optical element on an image forming area of the modulating device. The mounting position of the superimposing device may be adjustable.

This may increase the efficiency in the utilization of illumination light that illuminates the modulating device, thereby brightening a projected image. Even when the margin around the image forming area of the modulating device is narrowed, the illumination area relative to the modulating device is fine-adjusted so that the image forming area is kept within the illumination area and the projected image is free from the outlining shadow attributed to any offset between the image forming area and the illumination area.

After components of the optical systems are mounted, the image forming area of the modulating device is illuminated by the optical element and the superimposing device. When the illumination area is offset from the image forming area of the modulating device, the superimposing device is fine-adjusted so that the image forming area of the modulating device is fully included within the illumination area. Taking into consideration the offset between the illumination area and the image forming area, attributed to the positioning error of the optical components, the margin formed around the outline of the image forming area of the modulating device is narrowed.

Since the mounting position of the superimposing device, which is an optical component chiefly determining the illumination area of the modulating device, may be fine-adjusted, the position of the illumination area of the modulating device is easily and efficiently adjusted. The adjustment of the position of the illumination area is thus performed taking into consideration the overall mounting error of optical components (optical elements) in front of the superimposing device (upstream of the superimposing device in the optical path).

Since the plurality of split intermediate light beams are finally superimposed on a single illumination area through the superimposing device and are then delivered, a constant-brightness polarized light beam with no illuminance variations is obtained as an illumination light even when an incident light beam has a large light intensity distribution in its cross section. A constant-brightness polarized light beam with no illuminance variations may be obtained as an illumination light when the incident light beam has a uniform light intensity, when the intermediate light beam can-

not be separated into a p-polarized light and an s-polarized light beam because of spectral characteristics, or when the light intensity and spectral characteristics change in the course of aligning the polarization directions of both polarized light beams.

The projection-type display apparatus may present a particularly bright projected image that is uniform and bright on an entire display area or projection area.

A reflection device for bending an optical path may be disposed in the optical path extending from the light source to the modulating device. If an error is introduced in the mounting angle of the reflection device, the illumination area may be offset from the image forming area of the modulating device. The mounting angle of the reflection device is such that it is preferably adjustable relative to its incident optical axis.

The projection-type display apparatus may be applied to a projection-type display apparatus for projecting a color image. More particularly, it may be applied to a projection-type display apparatus including a color separating optical system for separating an output light from the superimposing device into color light beams, a plurality of modulating devices for modulating the color light beams separated by the color separating optical system, and a color synthesizing optical system for synthesizing the color light beams respectively modulated by the plurality of modulating device. The synthesized modulated light beam from the color synthesizing optical system may be enlarged and projected through the projection device to the projection area.

In the projection-type display apparatus for projecting a color image, a reflection device may be disposed in an optical path between the color separating optical system and at least one of the plurality of modulating devices. The illumination area may be offset depending on the mounting angle of the reflection device. The reflection device may be preferably adjustable in its mounting angle with respect to the incident optical axis.

The reflection device disposed closest to the modulating device remaining adjustable in its mounting angle is advantageous from the standpoint of assembling the apparatus and position adjusting the illumination area relative to the modulating device.

If the modulating device is a reflection type modulating device and the color separating optical system and the color synthesizing optical system are integrated into the same optical system, the optical path length is shortened to result in a compact-design projection-type display apparatus.

A second projection-type display apparatus of the present invention may include a light source, a first optical element for splitting a light beam from the light source into a plurality of intermediate light beams and a second optical element comprising a polarization conversion unit and a superimposing device for superimposing light beams output from the polarization conversion unit. The polarization conversion unit may be arranged in the vicinity of a position where the intermediate light beams are converged to separate each of the split intermediate light beams from the first optical element into a p-polarized light beam and an s-polarized light beam. The polarization conversion unit may further align the polarization direction of one of the p-polarized light beam and the s-polarized light beam with the polarization direction of the other of the p-polarized light beam and the s-polarized light beam and output the resulting light beams. A modulating device may modulate the light beams emitted from the second optical element and a projection device may enlarge and project the modulated

light beams from the modulating device to a projection area. The mounting position of the superimposing device may be adjustable.

The polarization conversion unit may be additionally provided besides the arrangement according to the first aspect, and thus, the second projection-type display apparatus presents the advantage offered by the use of the polarization conversion unit in addition to the advantage presented by the first projection-type display apparatus. More particularly, with the polarization conversion unit, polarizing light beams are efficiently used without wasting both light beams to thereby result in a bright projected image.

A reflection device for bending an optical path may be disposed in the optical path extending from the light source to the modulating device. The second projection-type display apparatus may be used in a projection-type display apparatus for projecting a color image. The mounting angle of the reflection device disposed closest to the modulating device may be adjustable and the modulating device may be a reflection type modulating device. Thus, the same advantages offered by the first projection-type display apparatus are achieved.

To make the mounting position of the superimposing device adjustable in the first projection-type display apparatus, an adjusting mechanism may be provided. More particularly, a first adjusting mechanism may be provided for adjusting the mounting position of the superimposing device in a first direction that is orthogonal to an optical axis. A second adjusting mechanism may be provided for adjusting the mounting position of the superimposing device in a second direction that is orthogonal to both the optical axis and the first direction.

A base adjusting plate may be provided to realize such an adjusting mechanism. Further, a first adjusting plate slidably movable in the first direction relative to the base adjusting plate and a second adjusting plate slidably movable in the second direction relative to the first adjusting plate may also be provided. With this mechanism, the mounting position of the superimposing device may be independently adjusted in individual directions (i.e., in the first and second directions).

The mounting position of the superimposing device may be difficult to adjust if the first adjusting plate is offset in the second direction when the second adjusting plate is slid in the second direction or if the second adjusting plate is offset in the first direction when the first adjusting plate is slid in the first direction. For this reason, the adjusting mechanism preferably includes a first slip prevention mechanism for preventing the first adjusting plate from slipping in the second direction and a second slip preventing mechanism for preventing the second adjusting plate from slipping in the first direction. This solves some of the above problems and the mounting position of the superimposing device is easily and accurately adjusted. When the adjusting mechanism including the first and second adjusting plates is employed, the superimposing device may be fixed to the second adjusting plate.

In the second projection-type display apparatus an adjusting mechanism may be provided to make the mounting position of the superimposing device adjustable.

Other objects, advantages and salient features of the invention will become apparent from the following detailed description taken in conjunction with the annexed drawings, which disclose preferred embodiments of the invention.

BRIEF DESCRIPTION OF THE DRAWINGS

The invention will be described with reference to the following drawings in which like reference numerals refer to like elements and wherein:

5

FIG. 1 is an external view of the projection-type display apparatus of the present invention;

FIG. 2(A) is a general plan view showing the internal structure of the projection-type display apparatus, and FIG. 2(B) is a sectional view of the apparatus;

FIG. 3 is a plan view showing an optical unit and a projection lens unit;

FIG. 4 is a general view of the optical system to be assembled in the optical unit;

FIGS. 5(A)–(D) show the relationship between an illumination area and a liquid-crystal light valve in an integrator optical system;

FIGS. 6(A)–(C) show a lens mounting position adjusting mechanism;

FIGS. 7(A) and (7B) are explanatory views showing the illumination areas of the integrator optical system by the reflection surface of the reflection device;

FIGS. 8(A)–(C) show the mechanism for fine-adjusting the mounting angle of the reflection mirror, FIG. 8(A) is an explanatory view of a holder plate, FIG. 8(B) is a plan view of the fine-adjustment mechanism, and FIG. 8(C) is a cross-sectional view of the fine-adjustment mechanism;

FIG. 9 is a general plan view showing the optical system of another example of the projection-type display apparatus of the present invention;

FIG. 10(A) is a perspective view showing a polarization separation unit array of FIG. 7, and FIG. 10(B) is an explanatory view showing the separation process of a polarization light beam by the polarization separation unit array;

FIG. 11 is a general plan view showing the optical system of another example of the projection-type display apparatus of the present invention;

FIG. 12 is an explanatory view showing the operation of the reflection-type liquid-crystal device of FIG. 9;

FIG. 13 is a general view of the optical system of a typical projection-type display apparatus equipped with an integrator optical system; and

FIG. 14 is an explanatory view showing the relationship between an illumination area and an image forming area in a liquid-crystal light valve.

DETAILED DESCRIPTION OF PREFERRED EMBODIMENTS

FIG. 1 shows an external view of the projection-type display apparatus of one embodiment of the present invention. The projection-type display apparatus 1000 picks up red, blue and green color light beams from a light emitted from a light source and passes the light beams through an integrator optical system and a color separating optical system. The apparatus further guides each color light beam to a liquid-crystal light valve arranged correspondingly to a respective color, modulates it according to a color video signal, synthesizes the modulated light beams for the three colors through a color synthesizing optical system, and then enlarges and projects the synthesized color image onto a projection screen.

As shown in FIG. 1, the projection-type display apparatus 1000 has a rectangular parallelepiped outer casing 2. The outer casing 2 may include an upper case 3, a lower case 4 and a front case 5 that forms the front of the apparatus. A projection lens unit 6 projects out of the center of the front case 5.

FIGS. 2(A)–2(B) show the positional relationship of components inside the outer casing 2 of the projection-type

6

display apparatus 1000. A power supply unit 7 is housed in the rear portion inside the outer casing 2. A light source lamp unit 8 is arranged in front of the power supply unit 7. An optical unit 9 is also arranged in front. The projection lens unit 6 is mounted with its base end portion positioned at the center front of the optical unit 9.

An interface board 11 is disposed on one side of the optical unit 9 having an input/output interface circuit that extends from front to back in the casing. A video board 12 having a video signal processing circuit extends in parallel with the interface board 11. A control board 13 for driving and controlling the apparatus is mounted above the light source lamp unit 8 and optical unit 9. Loudspeakers 14R, 14L are respectively installed on the left-front and right-front corners in the apparatus.

A suction fan 15A for cooling is installed on the center of the top surface of the optical unit 9 and a circulating fan 15B for circulating cooling air is attached on the center of the underside of the optical unit 9. Furthermore, an exhaust fan 16 is attached to the rear side of the light source lamp unit 8 facing one side of the apparatus. An auxiliary cooling fan 17 is disposed on one side of the power supply unit 7 close to the rear ends of the boards 11, 12 for sucking cooling air from the suction fan 15A into the power supply unit 7.

A floppy disk drive unit (FDD) 18 is disposed on top of the power supply unit 7 on the left-hand side of the apparatus.

FIG. 3 shows the optical unit 9 and the projection lens unit 6 dismounted from the casing. The optical unit 9 has optical elements (except a prism unit 910 constituting a color synthesizing device) interposed between upper and lower light guides 901, 902. The upper light guide 901 and lower light guide 902 are, respectively, secured to the upper case 3 and lower case 4 using fixing screws. The upper and lower light guides 901, 902 are also secured to sides of the prism unit 910 using fixing screws. The prism unit 910 is secured to the inside of a diecast head plate 903 using fixing screws. The base section of the projection lens unit 6 is bolted to the front side of the head plate 903.

FIG. 4 shows an optical system assembled into the optical unit 9. The optical system of this embodiment includes a discharge lamp 81, an element constituting the light source lamp unit 8 and an integrator optical system 923 including a first lens plate 921 and a second lens plate 922 as uniform illumination optical elements. The optical system further includes a color separating optical system 924 for separating a white light beam W emitted from the integrator optical system 923 into red, green and blue color light beams R, G, and B and three liquid-crystal light valves 925R, 925G, and 925B for respectively modulating the color light beams. The prism unit 910 synthesizes modulated color light beams and the projection lens unit 6 enlarges and projects the synthesized light beam to the surface of a screen 100. A light guide system 927 guides the blue color light beam B out of the color light beams separated by the color separating optical system 924 to a liquid-crystal light valve 925B.

A halogen lamp, a metal halide lamp or a xenon lamp may be used as the discharge lamp 81. The uniform illumination optical system 923 may be provided with a reflection mirror 931 that bends at a right angle the central optical axis 1a of the output light from the integrator optical system 923 toward the front of the apparatus. The first and second lens plates 921, 922 are perpendicular to a superimposing lens 930 with the mirror 931 located in between.

The output light from the discharge lamp 81 is reflected in the form of parallel light beams by the reflection surface

821 of a reflector 82 and is directed to the first lens plate 921. Then the light beams as a secondary light source image are directed to the incidence surface of each lens constituting the second lens plate 922 and the secondary light source images are superimposed through the superimposing lens 930 on objects to be illuminated. More particularly, the image forming areas of the liquid-crystal light valves 925R, 925G and 925B are illuminated.

The color separating optical system 924 may include a blue/green-reflecting dichroic mirror 941, a green-reflecting dichroic mirror 942, and a reflecting mirror 943. The blue light beam B and the green light beam G contained in the white light beam W are first reflected at a right angle from the blue/green-reflecting dichroic mirror 941 toward the green-reflecting mirror 942.

The red light beam R passes through the blue/green-reflecting dichroic mirror 941 and is reflected at a right angle from the reflecting mirror 943 downstream thereof and is delivered toward the prism unit 910 through the delivery section 944 for the red light beam. The green light beam G is reflected from the mirror 941 and is reflected at a right angle from the green-reflecting mirror 942 and is delivered toward the prism unit 910 through the delivery section 945 for the green light beam. The blue light beam B passing through the mirror 942 is delivered toward the light guide system 927 through the delivery section 946 for the blue light beam. In this embodiment, the distances from the delivery section of the white light beam of the integrator optical system 923 respectively to the delivery sections 944, 945, and 946 in the color separating optical system 924 are set to be equal.

Converging lenses 951, 952 are respectively arranged on the exit sides of the delivery sections 944, 945 for red and green light beams in the color separating optical system 924. These color light beams from the respective delivery sections are therefore made parallel through the converging lenses 951, 952.

The red and green light beams R, G in their parallel form are respectively introduced into the liquid-crystal light valves 925R, 925G to be modulated. Image information is imparted to each color light beam. More particularly, these light valves are switching-controlled by the image information by a driving device (not shown) and the color light beams passing therethrough are thus modulated. Any known device may be used as the driving device. The blue light beam B on the other hand is guided to the liquid-crystal light valve 925B through the light guide system 927, where it is equally modulated according to image information. The light valves in this embodiment may be the one that employs a polysilicon TFT as a switching element.

The light guide system 927 may include a converging lens 953, an input reflecting mirror 971, an output reflecting mirror 972, an intermediate lens 973 disposed between the input reflecting mirror 971 and the output reflecting mirror 972 and a converging lens 954 disposed in front of the liquid-crystal panel 925B. Among the lengths of the optical paths of the color light beams from the delivery section for the white light beam in the integrator optical system to the respective liquid-crystal light valves 925R, 925G and 925B, the length of the optical path of the blue light beam B is the longest and thus the blue light beam suffers a maximum loss. However, by arranging the light guide system 927 the light loss that the blue light beam suffers is restricted.

The color light beams modulated through the respective liquid-crystal light valves 925R, 925G, and 925B are introduced into the prism unit 910 to be synthesized. In this

embodiment, a dichroic prism is used as the color synthesizing optical system. A color image is enlarged and projected through the projection lens unit 6 to the screen 100 at a predetermined position.

In this projection-type display apparatus 1, the illumination area of the liquid-crystal light valve 925 determined by the integrator optical system 923 is fine-adjusted vertically up or down and horizontally to the left or right relative to the image forming area of the liquid-crystal light valve shown in FIG. 5.

FIG. 5(A) illustrates the relationship between the illumination area of the liquid-crystal light valve 925 determined by the integrator optical system 923 and the image forming area A of the liquid-crystal light valve 925. In FIG. 5(A), the projection area of the screen 100 is typically rectangular and the image forming area A of the liquid-crystal light valve 925 is accordingly rectangular. The illumination area B (represented by phantom lines) determined by the integrator optical system 923 is likewise rectangular.

The image forming area A of the liquid-crystal light valve 925 is sized to be distinctly smaller than the illumination area B. In other words, the display area A has a margin of a predetermined width. With the margin the image forming area A is continuously included within the illumination area B even if the illumination area B is offset in position because of the position errors of the first and second lens plates 921, 922 of the integrator optical system 923 and the superimposing lens 930.

The superimposing lens 930 may be fine-adjusted vertically and horizontally in a plane orthogonal to the optical axis 1a as shown by arrows using position adjusting mechanisms. For example, plate springs attached to the upper and lower light guides 901, 902 and position adjusting screws may be used as position adjusting mechanisms.

FIGS. 6(A)–6(C) show an example of a mechanism for fine-adjusting the mounting position of the superimposing lens 930 vertically and horizontally. FIG. 6(A) shows the mechanism for fine-adjusting the mounting position of the superimposing lens 930, viewed from the upstream side along the optical path. FIG. 6(B) shows the mechanism viewed from the side of the upper light guide 901 and FIG. 6(C) shows the mechanism viewed from its one side. A lens mounting position adjusting mechanism 700 is provided with a lower base plate 710, which in turn is bolted to the lower light guide 902. A lens adjusting base plate (base adjusting plate) 720 is secured to the lower base plate 710 such that the lens adjusting base plate 720 is orthogonal to the optical path. The lens adjusting base plate 720 has a vertical wall 721 and a horizontal flange 722 that horizontally extends from the center of the top edge of the vertical wall 721 toward the upstream side along the optical path (+Z direction). The vertical wall 721 supports a lens vertical adjusting plate (first adjusting plate) 730 in parallel therewith. The lens vertical adjusting plate 730 has bottom flanges 731a, 731b extending from its bottom edge toward an upstream side along the optical path and a top flange 732 extending from its top edge toward the upstream side along the optical path. The bottom flanges 731a, 731b of the lens vertical adjusting plate 730 are supported by an alignment spring 735 at the lower base plate 710 and the top flange 732 is pressed downward by an adjusting screw 736 attached to the top flange 722 of the lens adjusting base plate 720. By adjusting the screwed depth of the adjusting screw 736, the lens vertical adjusting plate 730 is shifted vertically upward or downward ($\pm Y$ directions) relative to the lens adjusting base plate 720.

The lens vertical adjusting plate **730** has a pair of slots **734** in the Y direction and the lens adjusting base plate **720** has a pair of projections **724** that are respectively received in the slots **734** as a slip prevention mechanism that prevents the lens vertical adjusting plate **730** from shifting leftward and rightward (in $\pm X$ directions) when the mounting position of the superimposing lens **930** is adjusted vertically upward or downward ($\pm Y$ directions) by using the adjusting screw **736**.

The lens vertical adjusting plate **730** supports a lens horizontal adjusting plate (second adjusting plate) **740** in parallel therewith. The lens vertical adjusting plate **730** has a pair of left-hand side and right-hand side flanges **733a**, **733b** extending toward the upstream side along the optical path while the lens horizontal adjusting plate **740** has side flanges **743a**, **743b** respectively extending in parallel with the side flanges **733a**, **733b**. The side flanges **743a** of the lens horizontal adjusting plate **740** is urged by an alignment spring **745** supported by the side flange **733a** toward the side flange **743b** while the side flange **743b** is pressed by an adjusting screw **746** attached to the side flange **733b** toward the side flange **743a**. By adjusting the screwed depth of the adjusting screw **746**, the lens horizontal adjusting plate **740** is shifted horizontally to the left or to the right (in $\pm X$ directions) relative to the lens vertical adjusting plate **730**.

The lens horizontal adjusting plate **740** has a pair of slots **747** in the X direction and the lens vertical adjusting plate **730** has a pair of projections **737** that are respectively received in the slots **747** as a slip prevention mechanism that prevents the lens horizontal adjusting plate **740** from shifting vertically upward and downward (in $\pm Y$ directions) when the mounting position of the superimposing lens **930** is adjusted to the left or to the right (in $\pm X$ directions) by using the adjusting screw **746**.

The superimposing lens **930** is attached to the lens horizontal adjusting plate **740** such that it occupies the generally central portion of the lens horizontal adjusting plate **740**. In this embodiment, the superimposing lens **930** is supported at part of its top portion by a bracket and at its bottom portion at two points by plate springs **752** fixed by screws **751**. Each of the three plates, which are components constituting the lens mounting position adjusting mechanism **700**, namely, the lens adjusting base plate **720**, lens vertical adjusting plate **730** and lens horizontal adjusting plate **740** is provided with an opening for guiding the light from the superimposing lens **930** to the color separating optical system.

In the lens mounting position adjusting mechanism **700**, the three plates (i.e., the lens adjusting base plate **720**, lens vertical adjusting plate **730** and lens horizontal adjusting plate **740**) are supported at four points, two on their top portion and two on their bottom portion, by U-shaped adjusting plate fixing springs **755**. For this reason, the mounting position of the superimposing lens **930** is adjusted vertically upward or downward, and horizontally to the left or to the right with the lens mounting position adjusting mechanism **700** remaining fixed to the lower light guide **902**. The lens adjusting base plate **720** and lens horizontal adjusting plate **740** are respectively provided with adhesive wells **728**, **748** on their top portions. After the adjustment of the mounting position of the superimposing lens **930** is complete, an adhesive is introduced into these wells through adhesive applying ports **904a**, **904b** (FIG. 3) formed in the upper light guide **901** to bond the three plates and thus prevent the superimposing lens **930** from offsetting from its mounting position.

The mounting position of the superimposing lens **930** is thus enabled to be fine-adjusted vertically upward or down-

ward and horizontally to the left or to the right and when the illumination area B is horizontally offset from the image forming area A of the liquid-crystal light valve **925** causing the image forming area A to be left partly unilluminated as shown in FIG. 5(B), the superimposing lens **930** is fine-adjusted in its position by tightening or loosening the adjusting screw **764** to horizontally move the position of the illumination area until the image forming area A is correctly put in the illumination area B as shown in FIG. 5(C). When the illumination area B is offset from the image forming area of the liquid-crystal light valve **925** with the image forming area A left partly unilluminated, the superimposing lens **930** is fine-adjusted in its mounting position vertically upward or downward by tightening or loosening the adjusting screw **736** to put the image forming area A correctly into the illumination area B in the same manner.

The fine-adjustment of the superimposing lens **930** in the horizontal direction ($\pm X$ direction) may be automatically or manually performed by measuring luminance in the periphery portion around the projected image formed by the liquid-crystal light valve **925G** and projected onto the screen. More particularly, in the condition shown in FIG. 5(B), the illumination area B is offset leftward, the illuminance drops in the rightmost portion of the image forming area of the liquid-crystal light valve **925G**. To correct the offset of the illumination area B, the superimposing lens **930** may be shifted in its mounting position horizontally to the left or to the right ($\pm X$ direction) until illuminances P1 and P2 on the left-hand side and right-hand side of the image forming area A become constant. Since this method sets a predetermined constant value beforehand, a difficulty is presented when the light source is changed to the one with small light intensity.

If the superimposing lens **930** is designed to shift horizontally in its mounting position to the left or to the right until luminances P1 and P2 on the left-hand side and right-hand side of the image forming area A become equal, the setting of the predetermined constant value is not required. Thus, this method works even when the light source is changed to one with small light intensity. Furthermore, if the superimposing lens **930** is designed to horizontally shift in its mounting position to the left or to the right until the sum of luminances P1 and P2 on the left-hand side and right-hand side of the image forming area A is maximized, the predetermined setting of the constant value is not required either. Thus, this method also works even when the light source is changed to one with small light intensity.

Instead of the method of measuring illuminance in the periphery portion of the image forming area A on the liquid-crystal light valve **925G**, fine-adjustment of the superimposing lens **930** in the horizontal direction ($\pm X$ direction) may be automatically or manually performed by measuring luminance in the periphery portion around the projected image on the screen **100** with the liquid-crystal light valve **925G** set to allow the illumination light to transmit there-through to form the image on the screen **100**.

When the screen **100** is illuminated as shown in FIG. 5(B), a projected image B' fails to appear on the leftmost portion of the area A' where the image would otherwise be projected as shown in FIG. 5(D). Accordingly, illuminance drops in the leftmost portion. By measuring illuminances Q1 and Q2 on the left-hand side and right-hand side of the area A' where the image is supposed to be projected, the superimposing lens **930** is fine-adjusted in the same manner that fine-adjustment is performed by measuring illuminance on the liquid-crystal light valve **925G**. More particularly, the

first lens plate **921** is horizontally shifted in its mounting position to the left or to the right until illuminances **Q1** and **Q2** become a constant value, or the first lens plate **921** is horizontally shifted in its mounting position to the left or to the right until illuminances **Q1** and **Q2** become equal, or the first lens plate **921** is shifted in its mounting position horizontally to the left or to the right until the sum of illuminances **Q1** and **Q2** is maximized. As already described, the first lens plate **921** is horizontally shifted in its mounting position to the left or to the right until illuminances **Q1** and **Q2** become equal or until the sum of illuminances **Q1** and **Q2** is maximized. Thus, fine-adjustment is carried out without any difficulty even when the light source is changed to one with small light intensity.

Fine-adjustment of the superimposing lens **930** in the vertical direction ($\pm Y$ direction) may be automatically or manually performed by measuring illuminances above and below the image forming area or the projected image. Like the horizontal fine-adjustment, vertical fine-adjustment is performed by vertically shifting the second lens plate **922** in its mounting position upward or downward until illuminances at two points become a constant value. Alternatively, the second lens plate **922** is vertically shifted in its mounting position upward or downward until the illuminances at two points become equal to each other or until the sum of the illuminances at two points is maximized. These methods work even when the light source is changed to one with small light intensity.

Fine-adjustment of the mounting position of the superimposing lens **930** may be performed using one of the remaining liquid-crystal light valves **925R** and **925B** as a reference instead of the liquid-crystal light valve **925G**.

With the superimposing lens **930** enabled to be fine-adjusted in its mounting position in this way, the necessity is eliminated for setting a wide margin around the image forming area **A** of the liquid-crystal light valves to cover the offset of the illumination area. Since a narrow margin around the image forming area **A** works, the efficiency in the utilization of the illumination light is heightened and the brightness of the projected image is increased.

Even with a narrow margin, fine-adjusting the mounting position of the superimposing lens **930** prevents the image forming area **A** from being left partly unilluminated as shown in FIG. **5(B)**. The outline of the projected image is thus free from shadowing.

In the projection-type display apparatus **1000**, the superimposing lens **930** arranged at the exit side of the integrator optical system **923** is the optical element that controls the illumination area of the liquid-crystal devices. Since the superimposing lens **930** is fine-adjusted in this embodiment, the position of the illumination area of the liquid-crystal light valve is easily and efficiently adjusted. More particularly, the optical components (the first and second lens plates **921**, **922**) arranged upstream of the superimposing lens **930** in the optical path are fixed and by adjusting only the mounting position of the superimposing lens **930**, the position of the illumination area **B** is adjusted taking into consideration the position errors of the optical components in the optical path upstream of the superimposing lens **930** to easily and efficiently perform the adjustment.

In this embodiment, the mounting position of the superimposing lens **930** is adjustable in only the directions (the $\pm X$ direction and $\pm Y$ direction) orthogonal to the optical axis **1a**. If the mounting position of the superimposing lens **930** in the direction of the optical axis **1a** ($\pm Z$ direction) is allowed to be adjustable, the illumination area formed on the

liquid-crystal light valve **925** can be fine-adjusted as well. More particularly, if fine-adjustment is performed along the optical axis **1a** after the mounting position of the superimposing lens **930** is adjusted in the directions orthogonal to the optical axis **1a**, the illumination area can be reduced to the smallest possible size. With an extremely narrow margin, the efficiency in the utilization of light is even more enhanced.

The mounting position of the superimposing lens **930** may be adjustable in any arbitrary direction orthogonal to the optical axis **1a**. With the mounting position of the superimposing lens **930** adjustable in any arbitrary direction orthogonal to the optical axis **1a**, the distortion of the illumination area **B** shown in FIG. **7** may be corrected to enhance the illumination uniformity.

An error in the mounting angle of the reflection surface of the reflecting mirror in the optical path for each color beam is also a factor contributing to offsetting the illumination area **B** of the output light from the superimposing lens **930** off the image forming area **A** of the liquid-crystal light valve **925**. The mounting angle of each reflecting mirror is angled at 45° with respect to the optical axis and if this angle suffers variations the illumination area **B** will be distorted as shown in FIGS. **7(A)** and **7(B)**. Thus, the image forming area **A** is partly offset from the illumination area **B** as shown in FIG. **5(B)**. If the illuminances on the left-hand side and on the right-hand side of the illumination area **B** become less uniform, even the advantage presented by the use of the integrator optical system **923** may be lost. For this reason, in the projection-type display apparatus **1000**, besides the fine-adjustment of the superimposing lens **930** already described, the angles of the reflection surfaces of the reflecting mirror **943** for reflecting the red light beam **R** toward the liquid-crystal light valve **925R** and the reflecting mirror **972** for reflecting the blue light beam **B** toward the liquid-crystal light valve **925B** shown in FIG. **4** are fine-adjusted about respective axes perpendicular to the planes in which the incident light axis and reflection light axis lie (in the directions shown by the arrows) with respect to the incident light axes. Plate springs and angle adjusting screws similar to those of the position adjusting mechanism for the superimposing lens **930** may be used as the mounting angle adjusting mechanism for the reflecting mirrors.

FIGS. **8(A)**–**8(C)** show an example of the mechanism for fine-adjusting the mounting angle of the reflecting mirror **972**. FIG. **8(A)** shows a holder plate **770** for holding the reflecting mirror **972**, FIG. **8(B)** shows the mounting angle adjusting mechanism for the reflecting mirror **972** viewed from the side of upper light guide **901**. FIG. **8(C)** shows the mounting angle adjusting mechanism for the reflecting mirror **972** taken along a cross-section **A—A** in FIG. **8(A)**. The mounting angle adjusting mechanism **760** includes the holder plate **770** with its holder sections **772a**, **772b** supporting the reflecting mirror **972** from the side opposite its reflection surface. The reflecting mirror **972** is also supported at its top edge by a clip **773** on the holder plate **770**. The holder plate **770** has a shaft **771** on its center extending vertically. The shaft **771** is rotatably supported by the lower light guide **902**. The reflecting mirror **972** is thus permitted to rotate about the axis **1b** of the shaft **771** of the holder plate **770** by a predetermined angle of travel.

The holder plate **770** is provided with a holder spring **774** on its one side portion and a first support point **775a** of an alignment spring **775** is inserted through the holder spring **774**. The arms **775d**, **775e** of the alignment spring **775** respectively abut spring pads **777a**, **777b** formed on the holder plate **770**. Second and third support points **775b**, **775c**

of the alignment spring 775 about a support section 778 provided on the lower light guide 902. The holder plate 770 is thus fixed to the lower light guide 902 through the alignment spring 775.

The holder plate 770 is pressed in the direction of the arrow B by an adjusting screw 776 supported by the lower light guide 902. An instrument is inserted through a screw driving port 779 formed in the lower light guide 902 to screw the adjusting screw 776 and increase its screwed depth. The one side portion of the holder plate 770 is pressed in the direction of +B by the adjusting screw 776, and the holder plate 770 is turned about the axis 1b of the shaft 771 in the direction of an arrow R1 as shown in FIG. 8(B). The angle of the reflection surface of the reflecting mirror 972 is changed to increase the angle of incidence of the light incident on the reflecting mirror 972. When the adjusting screw 776 is loosened to decrease its screwed depth on the other hand, one side of the holder plate 770 is drawn in the direction of -B by the alignment spring 775 and the holder plate 770 is turned about the axis 1b of the shaft 771 in the direction of an arrow R2 as shown in FIG. 8(B). The angle of the reflection surface of the reflecting mirror 972 is thus changed to decrease the angle of incidence of the light incident on the reflecting mirror 972. By changing the screwed depth of the adjusting screw 776, the angle of the reflection surface of the reflecting mirror 972 is adjusted about the axis 1b perpendicular to the plane in which the incident light axis and reflected light axis lie and the mounting angle of the reflection surface with respect to the incident light axis is thus adjusted.

The same mechanism as described above may be used as a mechanism for adjusting the angle of the reflection surface of the reflecting mirror 943.

After the mounting angles of the reflecting mirrors 943, 972 are fine-adjusted, an adhesive is applied through adhesive applying ports 906a, 906b, 907a and 907b (FIG. 3) formed in the upper light guide 901 to bond them. Although bonding these mirrors is not necessary, bonded mirrors 943 and 972 are effectively prevented from being offset under external shock.

The above described fine-adjustment may be automatically or manually performed by measuring illuminance in the periphery portion of the image forming area on the liquid-crystal light valve 925R or 925B. When the illumination area B is distorted as shown in FIGS. 7(A) and 7(B), the illuminances on the left-hand side and right-hand side of the illumination area B become less uniform and illuminance unbalance takes place. In the condition shown in FIG. 7(A), the illuminance P1 on the leftmost side is greater than the illuminance P2 on the rightmost side of the image forming area A and in the condition shown in FIG. 7(B), the illuminance P2 on the rightmost side is greater than the illuminance P1 on the leftmost side of the image forming area A. The mounting angles of the reflecting mirrors 943, 972 are adjusted until the illuminances P1, P2 on the left-hand side and right-hand side of the image forming area A become a constant value in the same way the lens plates are fine-adjusted as already described. To comply with the case where the light source is changed to one with small light intensity, the mounting angle of each of the reflecting mirrors 943, 972 is adjusted until the illuminances P1, P2 on the left-hand side and right-hand side of the image forming area A are equalized or until the sum of the illuminances P1, P2 on the left-hand side and right-hand side of the image forming area A is maximized.

Instead of the method of measuring illuminance in the periphery portion of the image forming area A on the

liquid-crystal light valve 925R or 925B and in the same way the superimposing lens 930 is fine-adjusted, fine-adjustment of each of the mirrors 943, 972 may be automatically or manually performed by measuring luminance in the periphery portion around the projected image on the screen 100 with the liquid-crystal light valve 925R or 925B set to allow the illumination light to transmit therethrough to form the image on the screen 100. More particularly, when the screen 100 is illuminated in the condition shown in FIG. 7(A) or 7(B), illuminances on the left-hand side and right-hand side of the projected image are unbalanced. By measuring the illuminances on the left-hand side and on the right-hand side of the projected image in the same way the image forming area A is measured in illuminance, the mounting angle of each of the reflecting mirrors 943, 972 is adjusted until illuminances on the left-hand side and on the right-hand side become a constant value, or until illuminances on the left-hand side and on the right-hand side are equalized, or until the sum of the illuminances on the left-hand side and on the right-hand side is maximized.

Both the reflecting mirrors 943 and 972 may be concurrently moved for fine-adjustment. However, fine-adjustments may be sequentially performed by moving the reflecting mirror 943 for angle adjustment using the projected image or the image forming area through the liquid-crystal light valve 925R as a reference and then moving the reflecting mirror 972 for angle adjustment using the projected image or the image forming area through the liquid-crystal light valve 925B as a reference.

Although in this embodiment, the reflecting mirrors 943, 972 respectively closest to the liquid-crystal light valves 925R, 925B are adjustable in their mounting angles, other optical elements, in combination with the light valves 925R, 925B, such as the blue/green-reflecting dichroic mirror 941, green-reflecting mirror 942 and converging lens 971 are all or partly fine-adjusted in mounting angle. Alternatively, instead of the reflecting mirrors 943, 972, these optical elements are all or partly fine-adjusted in mounting angle. The fine-adjustment of the reflecting mirrors 943, 972 respectively closest to the liquid-crystal light valve 925R, 925B in their mounting angle is the most effective in view of the construction of the apparatus and position adjustment accuracy.

Instead of the reflecting mirror 972, the intermediate lens 973 may be adjustable and such an arrangement presents the same advantage as the reflecting mirror 972 fine-adjusted.

With the reflecting mirrors 943, 972 enabled to be fine-adjusted in their mounting angle, the necessity for setting a wide margin around the image forming area A of the liquid-crystal light valve to cover the offset of the illumination area is eliminated. Since a narrow margin around the image forming area A works, the efficiency in the utilization of the illumination light is heightened and the brightness of the projected image is increased.

Even with a narrow margin, fine-adjusting the mounting angles of the reflecting mirrors 943, 972 prevents the image forming area A from being partly offset from the illumination area B as shown in FIGS. 7(A) and 7(B). The outline of the projected image is thus free from shadowing.

Since the distortion of the illumination area B is removed with the reflecting mirrors 943, 972 fine-adjusted, the uniform illumination featured by the integrator optical system 923 is fully exploited and a projected image is presented in an extremely uniform brightness.

The above-described angle adjusting mechanism for the optical elements such as the reflecting mirrors works effec-

tively in a projection-type display apparatus without the integrator optical system **923**.

Another modification of the projection-type display apparatus will now be discussed. FIG. **9** shows the optical system of the projection-type display apparatus **2000** including a polarization illumination unit with an integrator optical system and a polarization beam splitter with a special configuration. Components equivalent to those described in connection with the projection-type display apparatus **1000** in FIGS. **1** to **8** are designated with the same reference numerals, and the description of them is omitted.

FIG. **9** is a general view of the major portion of the projection-type display apparatus **2000** taken in the XZ plane. The projection-type display apparatus **2000** includes a polarization illumination unit **1**, a color separation device for separating a white light beam into three color components, three transmission-type liquid-crystal devices for respectively modulating three color lights according to image information and presenting a display image, a color synthesizing device for synthesizing three color lights to form a color image, and a projection optical system for projecting the color image for presentation.

The polarization illumination unit **1** includes a light source block **10** for outputting randomly polarized light beams in one direction. The randomly polarized light beams from the light source block **10** are converted into almost single type of polarized light beam through a polarization conversion block **20**.

The light source block **10** includes a light source lamp **101** and a paraboloidal reflector **102**. The light emitted from the light source lamp **101** is reflected by the paraboloidal reflector **102** in one direction and is directed in parallel beams to the polarization conversion block. The light source block **10** is arranged such that the light source optical axis R of the light source block **10** is offset in parallel in the X direction by a distance D from the optical axis L of the system.

The polarization conversion block **20** includes a first optical element **200** and a second optical element **300**.

The first optical element **200** corresponds to the first lens plate **921** in the projection-type display apparatus **1000** and includes a matrix of light splitting lenses **201** each having a rectangular shape in cross section in the XZ plane. The light source optical axis R is aligned with the center of the first optical element **200**. The light incident on the first optical element **200** is split into a plurality of intermediate light beams **202** that are spatially separated from each other. With the converging effect by the light splitting lenses **201**, images of the same number as the light splitting lenses **201** are formed where the intermediate light beams **202** are converged in a plane orthogonal to the system optical axis L (the XZ plane in FIG. **9**). The cross-sectional configuration of the light splitting lens **201** in the XY plane is similar to that of the image forming area of a liquid-crystal light valve. In this embodiment, the illumination area has a longer side along the X direction in the XY plane, and the cross-sectional configuration of the light splitting lenses **201** in the XY plane is also rectangular.

The second optical element **300** includes a converging lens array **310**, a polarization separation unit array **320**, a selective phase plate **380** and a superimposing lens **390** (a superimposing device). The second optical element **300** is disposed in a plane orthogonal to the system optical axis L (the XY plane in FIG. **9**) near the position where the images are converged by the first optical element **200**. When the light beams incident on the first optical element **200** exhibit

excellent parallelism, the second optical element may dispense with the converging lens array **310**. The converging lens array **310** as one component of the second optical element **300** and the first optical element **200** correspond to the integrator optical system in the projection-type display apparatus **1000**. The second optical element **300** separates spatially each of the intermediate light beams **202** into a p-polarized light beam and an s-polarized light beam, and aligns the direction of one of the light beams with the direction of the other light beam, guides light beams with their polarization direction aligned to a single illumination area.

The converging lens array **310** is substantially identical in construction to the first optical element **200**. More particularly, the converging lens array **310** has a matrix of converging lenses **311** having the same number as the light splitting lenses **201** (constituting the first optical element **200**) and converges and guides each intermediate light beam **202** at a particular position of the polarization separation unit array **320**. Each converging lens is preferably optimized taking into consideration the characteristics of the intermediate light beams **202** formed by the first optical element **200** and an ideal setup that the incident light on the polarization separation unit array **320** has its principal light beam in parallel with the system optical axis L. With a view to a low-cost design of the optical system and ease of design, the one identical to the first optical element **200** may be used as the converging lens array **310**, or a converging lens array of converging lenses each having a cross-sectional shape in the XY plane similar to that of the light splitting lens **201** may be used and the one identical to the first optical element **200** is used as the converging lens array **310**. The converging lens array **310** may be spaced from the polarization separation unit array **320** (closer to the first optical element **200**).

In FIGS. **10(A)** and **10(B)**, the polarization separation unit array **320** has a matrix of polarization separation units **330**. The first optical element **200** is a matrix of the concentric light splitting lenses **201** with the light splitting lens characteristics and the polarization separation unit array **320** is constructed by arranging identical polarization separation units **330** in the same direction in a matrix. If the polarization separation units in the same column in the Y direction are identical, they are preferably arranged with their longer sides aligned with the Y direction and shorter sides aligned with the X direction to constitute the polarization separation unit array **320** because light loss on the borders between polarization separation units are reduced while the manufacturing cost of the polarization separation unit array is also reduced.

The polarization separation unit **330** is a rectangular prism structure having a polarization separation face **331** and a reflection face **332** inside and spatially separates each of the intermediate light beams into a p-polarized light and an s-polarized light beam. The cross-sectional shape of the polarization separation unit **330** in the XY plane is similar to that of the light splitting lens **201** in the XY plane (i.e., a rectangular shape with its longer sides horizontal). The polarization separation face **331** and reflection face **332** are placed side by side in the horizontal direction (the X direction). As for the polarization separation face **331** and reflection face **332**, the polarization separation face **331** is angled at about 45° with respect to the system optical axis L. The reflection face **332** is in parallel with the polarization separation face **331** and both the polarization separation face **331** and reflection face **332** are arranged such that the area on the XY plane to which the polarization separation face **331** is projected (equal to the area of a p exit surface **333** to be described later) and is equal to the area on the XY plane

to which the reflection face **332** is projected (equal to the area of an s exit surface **334** to be described later). In this embodiment, the width W_p in the XY plane within a region where the polarization separation face **331** is present is set to be equal to the width W_m in the XY plane within a region where the reflection face **332** is present. The polarization separation face **331** is typically manufactured of dielectric multilayers and the reflection face **332** is typically manufactured of dielectric multilayers or an aluminum film.

The light incident on the polarization separation units **330** is separated through the polarization separation face **331** into a p-polarized light beam **335** passing through the polarization separation face **331** and an s-polarized light beam **336** that is reflected off the polarization separation face **331** and changes its direction of travel toward the reflection face **332**. The p-polarized light beam **335** is directly output past the p exit surface **333** from the polarization separation unit **330** while the s-polarized light beam **336** changes its direction of travel at the reflection face **332** travels in parallel with the p-polarized light beam **335** and is output past an s exit surface **334** from the polarization separation unit **330**. In this way, the randomly polarized light beams incident on the polarization separation units **330** are separated into two types of polarized light beams mutually different in polarization direction (i.e., the p-polarized light beam **335** and the s-polarized light beam **336**) both of which are output from two different places (the p exit surface **333** and the s exit surface **334**) but in almost the same direction. Since the polarization separation unit **330** works in this way, each intermediate light beam **202** needs to be guided to the region where the polarization separation face **331** of each polarization separation unit **330** is present. For this reason, the positional relationship between the polarization separation units **330** and the respective converging lenses **311** and the lens characteristics of each converging lens **311** are determined so that the intermediate light beam **202** is directed to the center of the polarization separation face **331** of each polarization separation unit **330**. In order to align the center axis of each converging lens **311** with the center of the respective polarization separation face **331** in the respective polarization separation unit **330**, the converging lens array **310** is shifted by a quarter of the horizontal width W of the polarization separation unit **330** in the X direction relative to the polarization separation unit array **320**.

The projection-type display apparatus **2000** of FIG. 9 will now be further discussed.

The selective phase plate **380** constructed of regularly arranged $\frac{1}{2}$ phase plates is disposed at the exit surface side of the polarization separation unit array **320**. More particularly, a $\frac{1}{2}$ phase plate is placed at the p exit surface **333** of each polarization separation unit **330** constituting the polarization separation unit array **320** and no $\frac{1}{2}$ phase plate is arranged at each s exit surface **334**. With such an arrangement of the $\frac{1}{2}$ phase plates, the p-polarized light beams output from the polarization separation units **330** are subjected to rotation of polarization direction while they pass through the $\frac{1}{2}$ phase plates and are converted to s-polarized light beams. On the other hand, the s-polarized light beams output from the s exit surfaces **334** pass no $\frac{1}{2}$ phase plate, are subjected to no change in polarization direction, and pass through the selective phase plate **380** as they are. The intermediate light beams **202** random in polarization direction are thus converted to one type of polarized light beams (the s-polarized light beams in this case) by the polarization separation unit array **320** and the selective phase plate **380**. The superimposing lens **390**, which is disposed at the side of the exit surface of the selective phase plate **380** (i.e., the exit

surface of the second optical element **300**) guides the light beams, now s-polarized through the selective phase plate **380**, to the illumination area of each liquid-crystal device and then superimposes the light beams on the illumination area. The superimposing lens **390** is not necessarily a single lens body, and may be a composite body of a plurality of lenses such as the first optical element **200** or the second lens plate **922** in the aforementioned projection-type display apparatus **1000**.

In summary, one of the functions of the second optical element **300** is to superimpose the intermediate light beams **202** split by the first optical element **200** (i.e., an image segmented by the light splitting lenses **201**) on the illumination area. Through its polarization separation unit array **320**, the second optical element **300** spatially separates the intermediate light beams **202**, which are the randomly polarized light beams, into the two types of polarized light beams mutually different in polarization direction and converts them into a single type of polarized light beams through the selective phase plate **380**. The image forming area of the liquid-crystal light valve is thus substantially uniformly illuminated with an almost single type of polarized light beams.

The polarization illumination unit **1** converts the randomly polarized light beams emitted from the light source block **10** into an almost single type of polarized light beams through the polarization conversion block **20** constructed of the first optical element **200** and second optical element **300** and illuminates the image forming area of the liquid-crystal light valve with the well aligned polarized light beams. Since the process of generating polarized light beams is associated with no substantial light loss, almost all of the light emitted from the light source block **10** is guided to the image forming area of the liquid-crystal light valve and the efficiency in the utilization of the light is very high.

Since the converging lens array **310**, polarization separation unit array **320** and selective phase plate **380**, all constituting the second optical element **300** are optically integrated in this embodiment, the light loss taking place in borders or interfaces are reduced and the efficiency in the utilization of the light is further enhanced.

To be compatible with the rectangular shape of the image forming area with its horizontal sides longer, each light splitting lens **201**, constituting the first optical element **200**, is also made rectangular with its horizontal sides longer, and the two types of polarized light beams output from the polarization separation unit array **320** are arranged in the horizontal direction (the X direction). Because of this, even the image forming area having a rectangular shape with its horizontal sides longer is illuminated, no light quantity is wasted, and the illumination efficiency (an utilization of light) of the liquid-crystal light valve is enhanced.

If light beams random in polarization direction are simply separated into a p-polarized light beam and an s-polarized light beam, the entire width of each beam after separation is doubled, and the optical system is accordingly enlarged. In the polarization illumination unit **1** of this embodiment, the first optical element **200** forms a plurality of small converging images, a space, generated in the course of the forming process of the images and having no light within, is skillfully exploited in a manner such that the reflection face **332** of the polarization separation unit **330** is arranged in that space, the horizontal expansion of each light beam arising from the separation of the beam into two beams is accommodated and the entire width of the light beam is free from expansion thus permitting a compact optical system design.

The projection-type display apparatus **2000** having the polarization illumination unit **1** employs a liquid-crystal device that modulates a single type of polarized light beams. If a conventional illumination device is used to guide randomly polarized light beams to the liquid-crystal device, polarizers (not shown) will absorb and convert almost half the randomly polarized light beams into heat, thereby not only degrading utilization of light but also requiring a noisy and large cooling device to control heat emitted from the polarizers. The projection-type display apparatus **2000** substantially eases this problem.

In its polarization illumination unit **1**, the projection-type display apparatus **2000** rotates the polarization direction of one type of polarized light beams only (e.g., p-polarized light beams only) through the $\frac{1}{2}$ phase plates to align them with the other type of polarized light beams (e.g., s-polarized light beams in polarization direction). For this reason, an almost single type of polarized light beams with their polarization directions aligned is guided to three liquid-crystal light valves **925R**, **925G**, and **925B**, absorption by the polarizers is extremely small, utilization of the light is enhanced to result in a bright projected image.

The polarization illumination unit **1** spatially separates two types of polarized light beams in the horizontal direction (the X direction) in the second optical element **300**. The polarization illumination unit **1** therefore wastes no light quantity and is best suited to illuminate a rectangular liquid-crystal device with its horizontal sides longer.

The polarization illumination unit **1** restricts the expansion of the light beam output from the incorporated polarization separation unit array **320** regardless of the incorporated polarization conversion optical elements. This means that when a liquid-crystal device is illuminated, practically no lights are incident on the liquid-crystal device with a large angle with respect thereto. A highly bright projected image is therefor formed without using a small f-number, large aperture projection lens. As a result, a compact projection-type display apparatus is provided.

Like the projection-type display apparatus **1000** already described, in the projection-type display apparatus **2000** the mounting position of the superimposing lens **390** disposed at the side of the exit surface of the polarization illumination unit **1** may be adjustable in the direction orthogonal to the optical axis L so that the illumination areas of the liquid-crystal light valves **925R**, **925G** and **925B** by the polarization illumination unit **1** are fine-adjusted horizontally forward or backward and horizontally to the left or to the right and the image forming area of each liquid-crystal device is continuously kept within the illumination area.

The lens mounting position adjusting mechanism described in FIG. **6** is available as a mechanism for adjusting the mounting position of the superimposing lens **390**. The fine-adjustment procedure and advantages achieved by the position adjustment of the illumination area remain unchanged from those already described in connection with the projection-type display apparatus **1000**.

In the projection-type display apparatus **2000**, fine-adjusting the mounting position of the superimposing lens **390** eliminates the need for setting a wide margin around the image forming area of the liquid-crystal device to cover the offset of the illumination area as in the conventional art. Since a narrow margin around the image forming area works, the utilization of the illumination light is increased and the projected image is brightened.

Even with a narrow margin, fine-adjusting the mounting position of each optical element prevents the image forming

area of the liquid-crystal device from being partly offset from the illumination area of the polarization separation unit array. The outline of the projected image is thus free from shadowing.

In the polarization illumination unit **1**, the superimposing lens **390** for superimposing the intermediate light beams on the illumination area is the optical element that controls the illumination area of the liquid-crystal device. With the superimposing lens **390** enabled to be fine-adjusted in this embodiment, the mounting position of the superimposing lens **390** only is adjusted with the optical components upstream of the superimposing lens **390** in the optical path fixed and the position of the illumination area B is thus adjusted taking into consideration the position errors of the optical components such as the first optical element **200** upstream of the superimposing lens **390** in the optical path. The position of the illumination area of the liquid-crystal light valve is efficiently adjusted and adjusting procedure itself is not time consuming.

An error in the mounting angle of the reflection surface of the reflecting mirror in the optical path for each color beam is also a factor contributing to offsetting the illumination area of the liquid-crystal device by the polarization illumination unit **1** from the image forming area of the liquid-crystal device. The mounting angle of each reflecting mirror is angled at 45° with respect to the optical axis. If this angle suffers variations, the illumination area will be distorted (FIGS. **7(A)** and **7(B)**) and the illumination area is partly projected out of the image forming area of the liquid-crystal device. When the illumination area is distorted in this way, the illuminances on the left-hand side and on the right-hand side of the illumination area become unbalanced, and even the advantage presented by the use of the polarization illumination unit **1** may be lost.

In the projection-type display apparatus **2000**, the angles of the reflection surfaces of the reflecting mirrors **943**, **972** in the respective color beam optical paths may be fine-adjusted with respect to the incident light axes about the axes perpendicular to the planes in which the incident light axis and the reflection light axis line (in the direction of the arrow in FIG. **9**). The mounting position of the intermediate lens **973** arranged between the reflecting mirrors **943**, **972** may be adjusted vertically upward or downward and horizontally to the left or to the right. The angle adjusting mechanism described in reference to FIG. **8** may be the mechanism for adjusting the mounting angle of each reflecting mirror. The lens mounting position adjusting mechanism described with reference to FIG. **6** may be the mechanism for adjusting the mounting position of the intermediate lens **973**.

In the two preceding embodiments, the liquid-crystal light valves **925R**, **925G** and **925B** are of a transmission type light valve. The present invention may be equally applied to a projection-type display apparatus employing a reflection-type liquid-crystal device. An example of the projection-type display apparatus employing a reflection-type light valve instead of a transmission-type light valve will now be described. In a projection-type display apparatus **3000** of this embodiment, components identical to those described with reference to FIGS. **9** and **10** are designated with the same reference numerals and the description of them is not repeated.

FIG. **11** shows the major portion of the projection-type display apparatus **3000** of this embodiment. FIG. **11** is a cross-sectional view of the second optical element **300** taken along the XZ plane.

A polarization beam splitter **400** includes a prism **401** that has an s-polarized light beam reflecting face **401** that reflects

an s-polarized light beam at 45° with respect to the XZ plane in FIG. 11 and permits a p-polarized light beam to transmit therethrough. Since the light beams output from the second optical element 300 are the ones having an almost single polarization direction, almost all light beams are reflected or transmitted through the polarization beam splitter 400. In this embodiment, the light beams output from the second optical element 300 are s-polarized light beams and the s-polarized light beams are bent at a right angle by an s-polarized light beam reflecting face 401 and are introduced to a prism unit 500 to which a dichroic film is glued in a cross configuration, and are separated into three color components R, G and B. Separated color component lights are respectively directed to reflection-type liquid-crystal devices 600R, 600G and 600B arranged along three sides of the dichroic prism 500. The light beams introduced into the reflection-type liquid-crystal devices 600R, 600G and 600B are modulated there.

FIG. 12 shows an example of the reflection-type liquid-crystal devices 600R, 600G, and 600B. The reflection-type liquid-crystal devices 600R, 600G, and 600B are an active matrix liquid-crystal device in which pixels are arranged in a matrix with a TFT switching element connected to each pixel and a liquid-crystal layer 620 interposed between a pair of substrates 610, 630. The substrate 610 is manufactured of silicon and has a source 611 and a drain 616. Also formed on the substrate 610 are a source electrode 612 and a drain electrode 617, both made of aluminum layers, a channel of silicon dioxide 613, a gate electrode of a silicon layer 614 and a tantalum layer 615, an interlayer insulating layer 618, and a reflection pixel electrode 619 of an aluminum layer, and the drain electrode 617 and the reflection pixel electrode 619 are electrically connected through a contact hole H. Since the reflection pixel electrode 619 is opaque, the interlayer insulating layer 618 is laminated over the gate electrode, the source electrode 612 and the drain electrode 617. Since the spacing between adjacent pixel electrodes 619 is made fairly small, a large aperture ratio of the device is permitted and a projected image is brightened. A holding capacitance may also be formed by the drain 616, a silicon dioxide layer 613', a silicon layer 614' and an tantalum layer 615'.

The opposed substrate 630 has an opposed electrode 631 of ITO on its side facing the liquid-crystal layer 620 and an anti-reflection layer 632 on the other side. A super-homeotropic type in which liquid-crystal molecules 621 orient vertically with no voltage applied (OFF) and twist by 90° with a voltage applied (ON) may be employed as the liquid-crystal layer 620 in this embodiment. As shown in FIG. 4, with no voltage applied (OFF), the s-polarized light beams are introduced from the polarization beam splitter 400 to the reflection-type liquid-crystal devices 600R, 600G and 600B are returned to the polarization beam splitter 400 without changing the polarization direction from the reflection-type liquid-crystal devices 600R, 600G and 600B, and are reflected by the s-polarized light beam reflecting face 401 without reaching the projection lens unit 6. With the voltage applied (ON), the s-polarized light beams introduced from the polarization beam splitter 400 to the reflection-type liquid-crystal devices 600R, 600G and 600B are converted to p-polarized light beams with their polarization direction changed by the twist of the liquid-crystal molecules 621, pass through the s-polarized light beam reflecting face 401, and are then projected to the screen 100 via the projection lens unit 6.

The operation of the projection-type display apparatus 3000 will now be discussed with reference to FIG. 11. The

light beams modulated through the reflection-type liquid-crystal devices 600R, 600G and 600B are synthesized by the prism unit 500 and are then projected to the screen 100 through the polarization beam splitter 400 and projection lens unit 6.

In the projection-type display apparatus 3000, the illumination area of the liquid-crystal device by the polarization illumination unit 1 is adjusted to its appropriate position and shape by enabling to be adjustable vertical upward or downward and horizontally to the left or to the right the mounting position of the superimposing lens 390 disposed at the side of the exit surface of the second optical element 300 constituting the polarization conversion block 20 in the polarization illumination unit 1. The position adjusting mechanism, procedure and advantage remain unchanged from those already described in connection with the projection-type display apparatus 2000.

Besides the advantage attributed to the adjustment of the illumination area, the projection-type display apparatus 3000 presents the same advantages as those of the above-described projection-type display apparatuses and further offers the following advantage. Since the color separation device and the color synthesizing device are integrated into the same prism unit, the optical path length is substantially shortened. The large aperture ratio of the liquid-crystal device minimizes light loss. A bright projected image is thus obtained without using a large aperture lens. With the first optical element and the second optical element, uniform polarized light beams with no illuminance variations are obtained, making the display area and the entire projection screen area uniform quality to result in an extremely bright projected image.

Although the reflection-type liquid-crystal devices 600R, 600G and 600B are used as the reflection-type modulating device in this embodiment, reflection-type modulating devices of non-liquid-crystal type may be used because its construction, materials of each element, and mode of operation of the liquid-crystal layer 620 are not limited to those already described above.

If a prism 403 constituting the polarization beam splitter 400 and a prism 501 constituting the prism unit 500 is integrated into a single prism, light loss taking place at the border therebetween will be eliminated and the utilization of light will be enhanced.

Although the above examples have been discussed in connection with the fine-adjustment mechanisms of the optical elements in the projection-type display apparatuses for projecting a color image, these fine-adjustment mechanisms are equally applied to a projection-type display apparatus for projecting a monochrome image.

The present invention is not limited to the layout of the optical systems, and modifications in the layout still fall within the scope of the present invention.

Besides the projection-type discussed above in which an image is projected to the screen from the viewing side of the screen, a rear-projection-type for projecting an image from the side opposite the viewing side of the screen is available. The present invention is applied to this rear-projection-type display apparatus.

As described above, the projection-type display apparatus of the present invention permits the mounting position of the superimposing device to be adjustable for superimposing a plurality of intermediate light beams on the image forming area of the modulating device. When the reflection device is arranged in the optical path between the light source and the modulating device, the mounting angle of the reflection

device is made adjustable. Since the position of the illumination area by the illumination light that illuminates the modulating means is fine-adjusted, the illumination area is positioned such that it always includes the image forming device of the modulating device within.

The above arrangement makes it unnecessary to set a large margin around the image forming area to cover the offset of the illumination area from the image forming area of the modulating device. The utilization of the illumination light is thus enhanced and the brightness of the projected image is heightened. Since the illumination area by the illumination light is positioned such that it includes the image forming area, no shadow is generated around the projected image.

Since the mounting position is fine-adjusted of the superimposing device, which is an optical component chiefly determining the illumination area of the modulating device, the adjustment of the position of the illumination area is thus performed taking into consideration the mounting errors of optical components (optical elements) in front of the superimposing device (upstream of the superimposing means). The position of the illumination area of the modulating device is easily and efficiently adjusted.

While the invention has been described in relation to preferred embodiments, many modifications and variations are intended to be within the scope of the present invention as defined in the appended claims.

What is claimed is:

1. A [projection-type display apparatus] *projector* comprising:

- a light source for emitting a light beam;
- modulating means for modulating the light beam emitted by the light source;
- projecting means for projecting the modulated light beam from the modulating means onto a projection screen;
- an optical element, disposed in an optical path between the light source and the modulating means, for splitting the light beam into a plurality of intermediate light beams; and
- superimposing means for superimposing each of the intermediate light beams onto an image forming area of the modulating means, wherein a mounting position of the superimposing means is adjustable.

2. The [projection-type display apparatus] *projector* of claim 1, further comprising reflection means in the optical path between the light source and the modulating means, wherein a mounting angle of the reflection means is adjustable with respect to an incident optical axis.

3. The [projection-type display apparatus] *projector* of claim 1, further comprising:

- a color separating optical system for separating an output light from the superimposing means into color light beams;
- a plurality of modulating means for modulating the color light beams separated by the color separating optical system;
- a color synthesizing optical system for synthesizing the color light beams modulated by the plurality of modulating means, wherein the synthesized modulated light beam from the color synthesizing optical system is enlarged and projected to the projection screen by the projection means; and
- reflection means disposed in an optical path between the color separating optical system and at least one of the plurality of modulating means, wherein a mounting

angle of the reflection means is adjustable with respect to an incident optical axis.

4. The [projection-type display apparatus] *projector* of claim 3, wherein a mounting angle of the reflection means located closest to the modulating means is adjustable.

5. The [projection-type display apparatus] *projector* of claim 3, wherein the modulating means is a reflection type modulating means and the color separating optical system and the color synthesizing optical system are integrated into the same optical system.

6. A [projection-type display apparatus] *projector* comprising:

- a light source for outputting a light beam;
- a first optical element for splitting the light beam output from the light source into a plurality of intermediate light beams;
- a second optical element including a polarization conversion unit and superimposing means for superimposing light beams output from the polarization conversion unit, wherein the second optical element is arranged in a vicinity of a position where the intermediate light beams are converged, the second optical element separates each of the intermediate light beams from the first optical element into a p-polarized light beam and a s-polarized light beam, the second optical element further aligns a polarization direction of one of the p-polarized light beam and the s-polarized light beam with the polarization direction of the other of the p-polarized light beam and the s-polarized light beam, and the second optical element outputs the resulting light beams;
- modulating means for modulating the light beams emitted from the second optical element; and
- projection means for enlarging and projecting the modulated light beams from the modulating means to a projection screen, wherein a mounting position of the superimposing means is adjustable.

7. The [projection-type display apparatus] *projector* of claim 6, further comprising reflection means in an optical path between the light source and the modulating means, wherein a mounting angle of the reflection means is adjustable with respect to an incident optical axis.

8. The [projection-type display apparatus] *projector* of claim 6, further comprising:

- a color separating optical system for separating an output light from the superimposing means into color light beams;
- a plurality of modulating means for modulating the color light beams separated by the color separating optical system;
- a color synthesizing optical system for synthesizing the color light beams modulated by the plurality of modulating means, wherein the synthesized modulated light beam from the color synthesizing optical system is enlarged and projected to the projection means to the projection screen; and
- reflection means located in an optical path between the color separating optical system and at least one of the plurality of modulating means, wherein a mounting angle of the reflection means is adjustable with respect to an incident optical axis.

9. The [projection-type display apparatus] *projector* of claim 8, wherein a mounting angle of the reflection means located closest to the modulating means is adjustable.

10. The [projection-type display apparatus] *projector* of claim 8, wherein the modulating means is a reflection type

modulating means and the color separating optical system and the color synthesizing optical system are integrated into the same optical system.

11. A [projection-type display apparatus] *projector* comprising:

- a light source that emits a light beam;
- modulating means for modulating the light beam emitted by the light source;
- projection means for enlarging and projecting the modulated light beam from the modulating means onto a projection screen;
- an optical element, located in an optical path between the light source and the modulating means, that splits the light beam emitted from the light source into a plurality of intermediate light beams;
- superimposing means for superimposing each of the intermediate light beams from the optical element onto an image forming area of the modulating means; and
- an adjusting mechanism that adjusts a mounting position of the superimposing means.

12. The [projection-type display apparatus] *projector* of claim 11, further comprising:

- a first adjusting mechanism that adjusts the mounting position of the superimposing means in a first direction that is orthogonal to an optical axis; and
- a second adjusting mechanism that adjusts the mounting position of the superimposing means in a second direction that is orthogonal to the optical axis and the first direction.

13. The [projection-type display apparatus] *projector* of claim 12, wherein the adjusting mechanism comprises:

- a base adjusting plate;
- a first adjusting plate slidably movable in the first direction relative to the base adjusting plate; and
- a second adjusting plate slidably movable in the second direction relative to the first adjusting plate.

14. The [projection-type display apparatus] *projector* of claim 13, wherein the adjusting mechanism comprises a first slip prevention mechanism that prevents the first adjusting plate from slipping in the second direction and a second slip prevention mechanism for preventing the second adjusting plate from slipping in the first direction.

15. The [projection-type display apparatus] *projector* of claim 13, wherein the superimposing means is fixed to the second adjusting plate.

16. A [projection-type display apparatus] *projector* comprising:

- a light source that outputs a light beam;
- a first optical element that splits a light beam from the light source into a plurality of intermediate light beams;
- a second optical element including a polarization conversion unit and superimposing means for superimposing light beams output from the polarization conversion unit, wherein the second optical element is arranged in a vicinity of a position where the intermediate light beams are converged, the second optical element separates the intermediate light beams from the first optical element into a p-polarized light beam and a s-polarized light beam, the second optical element aligns a polarization direction of one of a p-polarized light beam and a s-polarized light beam with the polarization direction of the other of the p-polarized light beam and the s-polarized light beam, and the second optical element outputs the resulting light beams;
- modulating means for modulating the light beams emitted from the second optical element;

projection means for enlarging and projecting the modulated light beams from the modulating means onto a projection screen; and

an adjusting mechanism for adjusting a mounting position of the superimposing means.

17. The [projection-type display apparatus] *projector* of claim 16, further comprising:

- a first adjusting mechanism that adjusts the mounting position of the superimposing means in a first direction that is orthogonal to an optical axis; and
- a second adjusting mechanism for adjusting the mounting position of the superimposing means in a second direction that is orthogonal to the optical axis and the first direction.

18. The [projection-type display apparatus] *projector* of claim 17, wherein the adjusting mechanism comprises:

- a base adjusting plate;
- a first adjusting plate slidably movable in the first direction relative to the base adjusting plate; and
- a second adjusting plate slidably movable in the second direction relative to the first adjusting plate.

19. The [projection-type display apparatus] *projector* of claim 18, wherein the adjusting mechanism comprises a first slip prevention mechanism that prevents the first adjusting plate from slipping in the second direction and a second slip prevention mechanism that prevents the second adjusting plate from slipping in the first direction.

20. *The projector of claim 3, further comprising:*

- a light guiding system disposed in a longest optical path between the color separating optical system and each of the plurality of modulating means, the light guiding system including two lenses and an intermediate lens disposed between the two lenses, a position of the intermediate lens being adjustable.*

21. *The projector of claim 8, further comprising:*

- a light guiding system disposed in a longest optical path between the color separating optical system and each of the plurality of modulating means, the light guiding system including two lenses and an intermediate lens disposed between the two lenses, a position of the intermediate lens being adjustable.*

22. *The projector of claim 11, further comprising:*

- a color separating optical system that separates the light emitted from the superimposing means into a plurality of color lights;*

a plurality of the modulating means that each modulates the color light separated by the color separating optical system;

- a light guiding system disposed in a longest optical path between the color separating optical system and each of the plurality of modulating means, the light guiding system including two lenses and an intermediate lens disposed between the two lenses; and*

a further adjusting mechanism that adjusts a position of the intermediate lens.

23. *The projector of claim 16, further comprising:*

- a color separating optical system that separates the light emitted from the superimposing means into a plurality of color lights;*

a plurality of the modulating means that each modulates the color light separated by the color separating optical system;

- a light guiding system disposed in a longest optical path between the color separating optical system and each*

27

of the plurality of modulating means, the light guiding system including two lenses and an intermediate lens disposed between the two lenses; and

a further adjusting mechanism that adjusts a position of the intermediate lens.

24. A projector comprising:

a light source for emitting a light beam;

modulating means for modulating the light beam emitted by the light source;

projecting means for projecting the modulated light beam from the modulating means onto a projection screen;

an optical element, disposed in an optical path between the light source and the modulating means, for splitting the light beam into a plurality of intermediate light beams;

superimposing means for superimposing each of the intermediate light beams onto an image forming area of the modulating means;

a power supply;

an input/output interface circuit;

a video signal processing circuit;

a control circuit for driving and controlling the projector; and

an outer casing for housing the light source, the modulating means, the optical element, the superimposing means, the power supply, the input-output interface circuit, the video signal processing circuit, and the control circuit, wherein, a mounting position of the superimposing means is adjustable.

25. The projector of claim 24, further comprising reflection means in the optical path between the light source and the modulating means, wherein a mounting angle of the reflection means is adjustable with respect to an incident optical axis.

26. The projector of claim 25, further comprising:

a color separating optical system for separating an output light from the superimposing means into color light beams;

a plurality of modulating means for modulating the color light beams separated by the color separating optical system;

a color synthesizing optical system for synthesizing the color light beams modulated by the plurality of modulating means, wherein the synthesized modulated light beam from the color synthesizing optical system is enlarged and projected to the projection screen by the projection means; and

reflection means disposed in an optical path between the color separating optical system and at least one of the plurality of modulating means, wherein a mounting angle of the reflection means is adjustable with respect to an incident optical axis.

27. The projector of claim 26, wherein a mounting angle of the reflection means located closest to the modulating means is adjustable.

28. The projector of claim 26, wherein the modulating means is a reflection type modulating means and the color separating optical system and the color synthesizing optical system are integrated into the same optical system.

29. The projector of claim 26, further comprising:

a light guiding system disposed in a longest optical path between the color separating optical system and each of the plurality of modulating means, the light guiding system including two lenses and an intermediate lens

28

disposed between the two lenses, a position of the intermediate lens being adjustable.

30. A projector comprising:

a light source for emitting a light beam;

a first optical element for splitting the light beam output from the light source into a plurality of intermediate light beams;

a second optical element including a polarization conversion unit and superimposing means for superimposing light beams output from the polarization conversion unit, wherein the second optical element is arranged in a vicinity of a position where the intermediate light beams are converged, the second optical element separates each of the intermediate light beams from the first optical element into a p-polarized light beam and an s-polarized light beam, the second optical element further aligns a polarization direction of one of the p-polarized light beam and the s-polarized light beam, and the second optical element outputs the resulting light beams;

modulating means for modulating the light beam emitted from the second optical element;

projecting means for enlarging and projecting the modulated light beams from the modulating means onto a projection screen;

a power supply;

an input/output interface circuit;

a video signal processing circuit;

a control circuit for driving and controlling the projector; and

an outer casing for housing the light source, the first and second optical elements, the modulating means, the power supply, the input-output interface circuit, the video signal processing circuit, and the control circuit, wherein, a mounting position of the superimposing means is adjustable.

31. The projector of claim 30, further comprising reflection means in the optical path between the light source and the modulating means, wherein a mounting angle of the reflection means is adjustable with respect to an incident optical axis.

32. The projector of claim 30, further comprising:

a color separating optical system for separating an output light from the superimposing means into color light beams;

a plurality of modulating means for modulating the color light beams separated by the color separating optical system;

a color synthesizing optical system for synthesizing the color light beams modulated by the plurality of modulating means, wherein the synthesized modulated light beam from the color synthesizing optical system is enlarged and projected to the projection means to the projection screen; and

reflection means located in an optical path between the color separating optical system and at least one of the plurality of modulating means, wherein a mounting angle of the reflection means is adjustable with respect to an incident optical axis.

33. The projector of claim 27, wherein a mounting angle of the reflection means located closest to the modulating means is adjustable.

34. The projector of claim 27, wherein the modulating means is a reflection type modulating means and the color separating optical system and the color synthesizing optical system are integrated into the same optical system.

35. The projector of claim 32, further comprising:
 a light guiding system disposed in a longest optical path between the color separating optical system and each of the plurality of modulating means, the light guiding system including two lenses and an intermediate lens disposed between the two lenses, a position of the intermediate lens being adjustable.
36. A projector comprising:
 a light source for emitting a light beam;
 modulating means for modulating the light beam emitted by the light source;
 projecting means for projecting the modulated light beam from the modulating means onto a projection screen;
 an optical element, located in an optical path between the light source and the modulating means, that splits the light beam emitted from the light source into a plurality of intermediate light beams;
 superimposing means for superimposing each of the intermediate light beams onto an image forming area of the modulating means;
 an adjusting mechanism that adjusts a mounting position of the superimposing means;
 a power supply;
 an input/output interface circuit;
 a video signal processing circuit;
 a control circuit for driving and controlling the projector;
 and
 an outer casing for housing the light source, the modulating means, the optical element, the superimposing means, the adjusting mechanism, the power supply, the input-output interface circuit, the video signal processing circuit, and the control circuit.
37. The projector of claim 36, further comprising:
 a color separating optical system that separates the light emitted from the superimposing means into a plurality of color lights;
 a plurality of the modulating means that each modulates the color light separated by the color separating optical system;
 a light guiding system disposed in a longest optical path between the color separating optical system and each of the plurality of modulating means, the light guiding system including two lenses and an intermediate lens disposed between the two lenses; and
 a further adjusting mechanism that adjusts a position of the intermediate lens.
38. The projector of claim 36, further comprising:
 a first adjusting mechanism that adjusts the mounting position of the superimposing means in a first direction that is orthogonal to an optical axis; and
 a second adjusting mechanism that adjusts the mounting position of the superimposing means in a second direction that is orthogonal to the optical axis and the first direction.
39. The projector of claim 38, wherein the adjusting mechanism comprises:
 a base adjusting plate;
 a first adjusting plate slidably movable in the first direction relative to the base adjusting plate; and
 a second adjusting plate slidably movable in the second direction relative to the first adjusting plate.
40. The projector of claim 39, wherein the adjusting mechanism comprises a first slip prevention mechanism that

- prevents the first adjusting plate from slipping in the second direction and a second slip prevention mechanism for preventing the second adjusting plate from slipping in the first direction.
41. The projector of claim 39, wherein the superimposing means is fixed to the second adjusting plate.
42. A projector comprising:
 a light source for emitting a light beam;
 a first optical element for splitting the light beam output from the light source into a plurality of intermediate light beams;
 a second optical element including a polarization conversion unit and superimposing means for superimposing light beams output from the polarization conversion unit, wherein the second optical element is arranged in a vicinity of a position where the intermediate light beams are converged, the second optical element separates each of the intermediate light beams from the first optical element into a p-polarized light beam and an s-polarized light beam, the second optical element further aligns a polarization direction of one of the p-polarized light beam and the s-polarized light beam, and the second optical element outputs the resulting light beams;
 modulating means for modulating the light beam emitted from the second optical element;
 projecting means for enlarging and projecting the modulated light beam from the modulating means onto a projection screen;
 an adjusting mechanism for adjusting a mounting position of the superimposing means;
 a power supply;
 an input/output interface circuit;
 a video signal processing circuit;
 a control circuit for driving and controlling the projector;
 and
 an outer casing for housing the light source, the first and second optical elements, the modulating means, the adjusting mechanism, the power supply, the input-output interface circuit, the video signal processing circuit, and the control circuit.
43. The projector of claim 42, further comprising:
 a color separating optical system that separates the light emitted from the superimposing means into a plurality of color lights;
 a plurality of the modulating means that each modulates the color light separated by the color separating optical system;
 a light guiding system disposed in a longest optical path between the color separating optical system and each of the plurality of modulating means, the light guiding system including two lenses and an intermediate lens disposed between the two lenses; and
 a further adjusting mechanism that adjusts a position of the intermediate lens.
44. The projector of claim 43, further comprising:
 a first adjusting mechanism that adjusts the mounting position of the superimposing means in a first direction that is orthogonal to an optical axis; and
 a second adjusting mechanism that adjusts the mounting position of the superimposing means in a second direction that is orthogonal to the optical axis and the first direction.

31

45. The projector of claim 44, wherein the adjusting mechanism comprises:

a base adjusting plate;

a first adjusting plate slidably movable in the first direction relative to the base adjusting plate; and

a second adjusting plate slidably movable in the second direction relative to the first adjusting plate.

32

46. The projector of claim 45, wherein the adjusting mechanism comprises a first slip prevention mechanism that prevents the first adjusting plate from slipping in the second direction and a second slip prevention mechanism that prevents the second adjusting plate from slipping in the first direction.

* * * * *