



US00RE38040E

(19) **United States**
(12) **Reissued Patent**
Spear et al.

(10) **Patent Number: US RE38,040 E**
(45) **Date of Reissued Patent: Mar. 18, 2003**

(54) **SWEPT TURBOMACHINERY BLADE**

FOREIGN PATENT DOCUMENTS

(75) Inventors: **David A. Spear**, deceased, late of Manchester, CT (US); **by Dennis N. Kantor**, executor, East Hartford, CT (US); **Bruce P. Biederman**, West Hartford, CT (US); **John A. Orosa**, Palm Beach Gardens, FL (US)

EP	0266298	5/1988
EP	0774567	5/1997
EP	0801230	10/1997
FR	2459387	1/1981
SU	1528965	12/1989
WO	WO9107593	5/1991

(73) Assignee: **United Technologies Corporation**, Hartford, CT (US)

OTHER PUBLICATIONS

(21) Appl. No.: **09/343,736**

Leading edge sweep angle profiles of fan blades of Pratt & Whitney PW305 and PW306 gas turbine engines (no date). Puterbaugh et al., "Design of a Rotor Incorporating Meridional Sweep and Circumferential Lean for Shock Loss Attenuation," Feb. 1987, Contract AFWAL-TR-86-2013, Aero Propulsion Laboratories, Air Force Wright Aeronautical Laboratories, Wright-Patterson Air Force Base, Ohio. Cheatham et al., "Parametric Blade Study," Nov. 1989, Report No. WRDC-TR-89-2121, Aero Propulsion and Power Laboratory, Wright Aeronautical Research & Development Center, Wright-Patterson Air Force Base, Ohio. European Search Report, dated Feb. 25, 1998, in EP 774,567.

(22) Filed: **Jun. 30, 1999**

European Patent Office Official Action, dated Sep. 24, 1998, in EP 774,567.

Related U.S. Patent Documents

Reissue of:

(64) Patent No.: **5,642,985**
Issued: **Jul. 1, 1997**
Appl. No.: **08/559,965**
Filed: **Nov. 17, 1995**

Primary Examiner—Christopher Verdier

U.S. Applications:

(63) Continuation of application No. 09/874,931, filed on Jun. 5, 2001.

(74) *Attorney, Agent, or Firm*—David M. Quinlan, P.C.

(51) **Int. Cl.**⁷ **F01D 5/14**

(57) **ABSTRACT**

(52) **U.S. Cl.** **415/181; 416/238; 416/242**

(58) **Field of Search** **415/181, 220; 416/238, 242, 243**

A swept turbomachinery blade for use in a cascade of such blades is disclosed. The blade (12) has an airfoil (22) uniquely swept so that an endwall shock (64) of limited radial extent and a passage shock (66) are coincident and a working medium (48) flowing through interblade passages (50) is subjected to a single coincident shock rather than the individual shocks. In one embodiment of the invention the forwardmost extremity of the airfoil defines an inner transition point (40) located at an inner transition radius $r_{t-inner}$. The sweep angle of the airfoil is nondecreasing with increasing radius from the inner transition radius to an outer transition radius $r_{t-outer}$, radially inward of the airfoil tip (26), and is nonincreasing with increasing radius between the outer transition radius and the airfoil tip.

(56) **References Cited**

U.S. PATENT DOCUMENTS

1,964,525 A	6/1934	McMahan	170/159
2,154,313 A	4/1939	McMahan	230/274
2,628,768 A	2/1953	Kantrowitz	
2,660,401 A *	11/1953	Hull, Jr.	416/243
2,689,681 A	9/1954	Sabatiuk	
2,915,238 A	12/1959	Szydlowski	230/134
2,934,259 A	4/1960	Hausmann	415/181
2,935,246 A	5/1960	Roy	415/181
3,416,725 A	12/1968	Bohanon	230/259

(List continued on next page.)

37 Claims, 7 Drawing Sheets

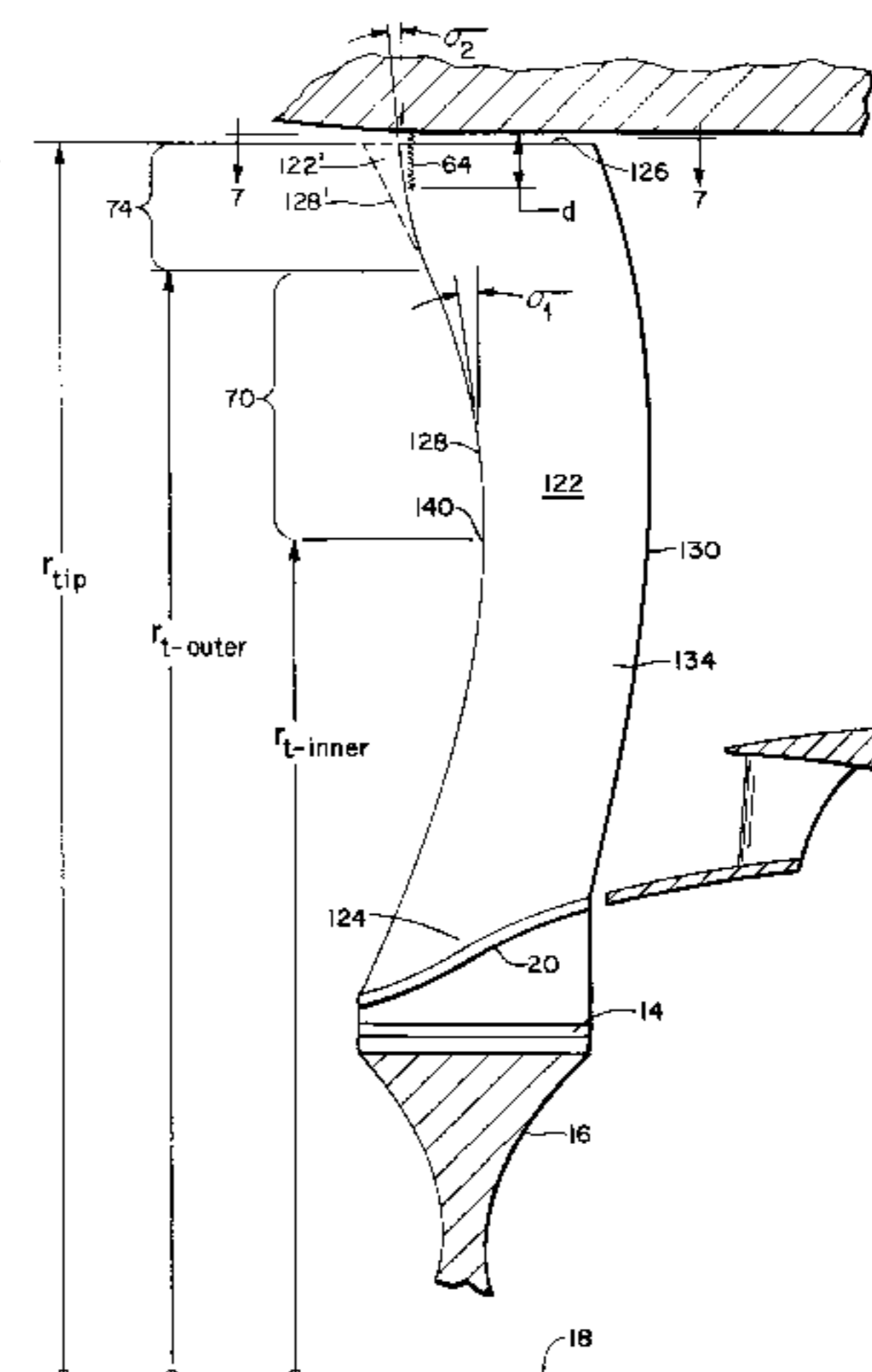
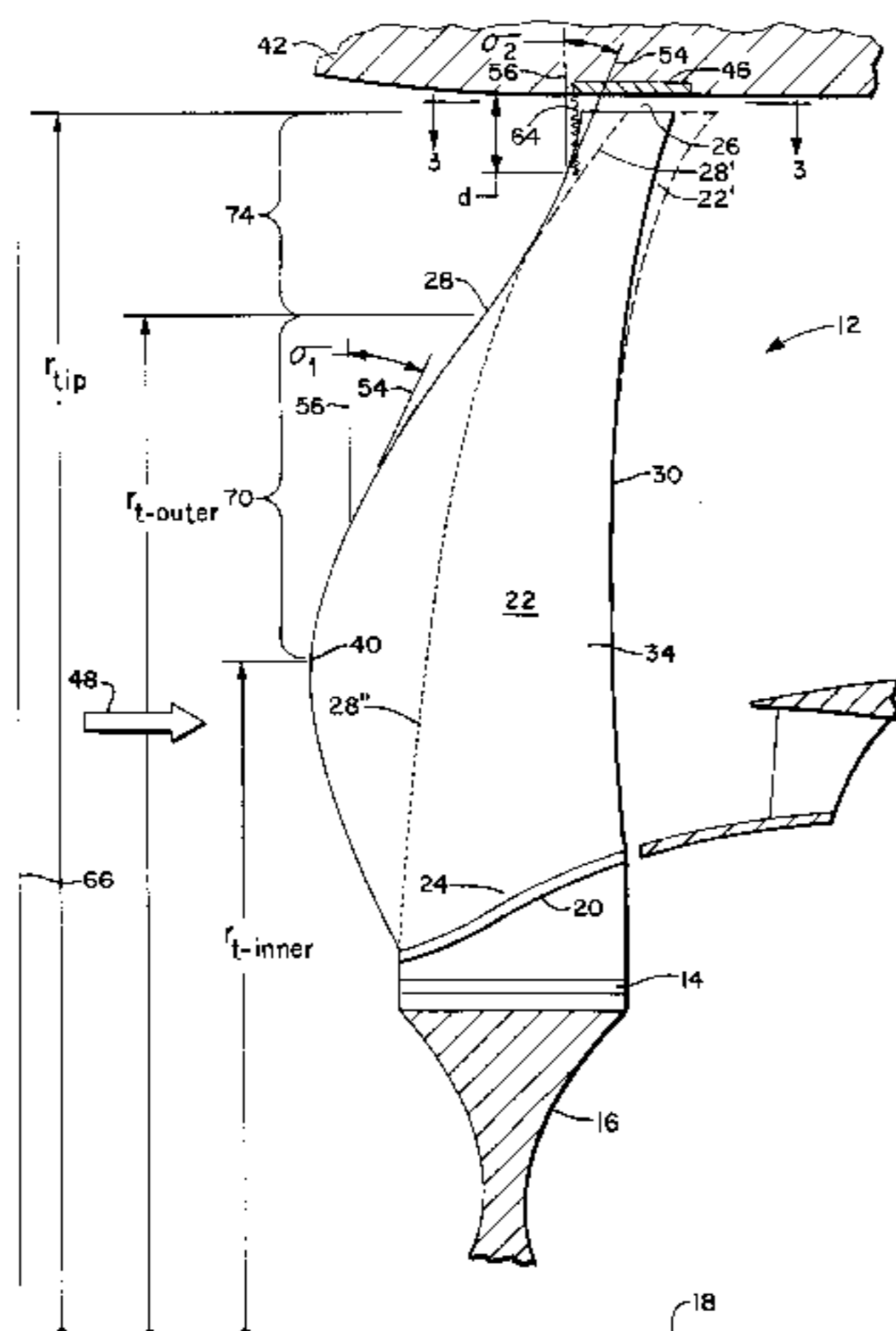

US RE38,040 E

Page 2

U.S. PATENT DOCUMENTS						
3,444,817 A	5/1969	Caldwell	103/88	4,726,737 A	2/1988 Weingold et al.	416/223 A
3,692,425 A	9/1972	Erwin	415/181	4,737,077 A	4/1988 Vera	416/242
3,989,406 A	11/1976	Bliss	415/1	4,784,575 A	11/1988 Nelson et al.	416/226
4,012,165 A	3/1977	Kraig	415/145	5,064,345 A	11/1991 Kimball	416/169 A
4,012,172 A	3/1977	Schwaar et al.	416/228	5,112,192 A	5/1992 Weetman	416/201 A
4,358,246 A	11/1982	Hanson et al.	416/223 R	5,167,489 A	12/1992 Wadia et al.	415/182.1
4,370,097 A	1/1983	Hanson et al.	416/228	5,584,661 A	12/1996 Brooks	416/238
4,408,957 A	10/1983	Kurzock et al.	415/181	6,071,077 A	6/2000 Rowlands	
4,714,407 A	* 12/1987	Cox et al.	415/181			

* cited by examiner

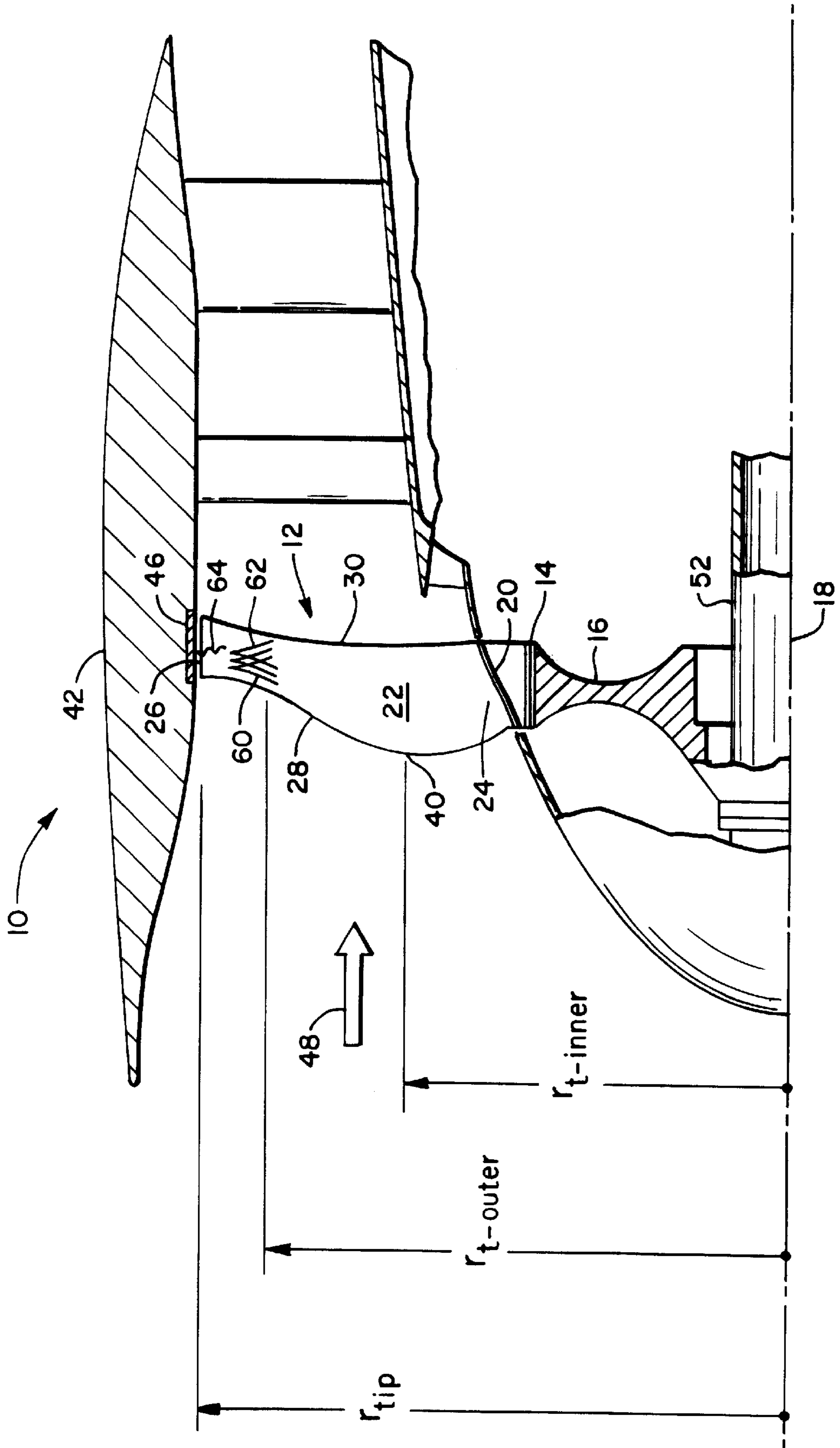
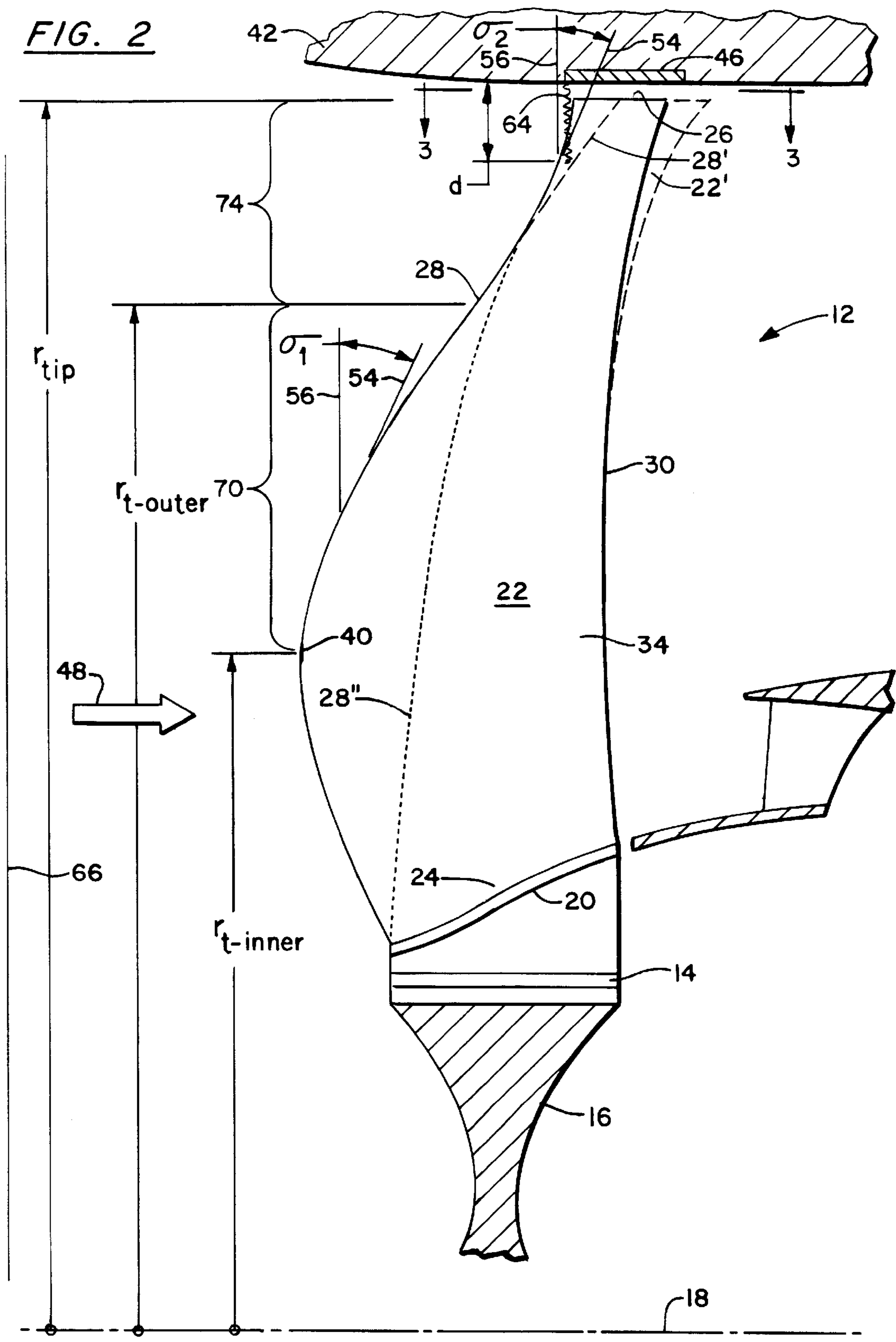

FIG. 1



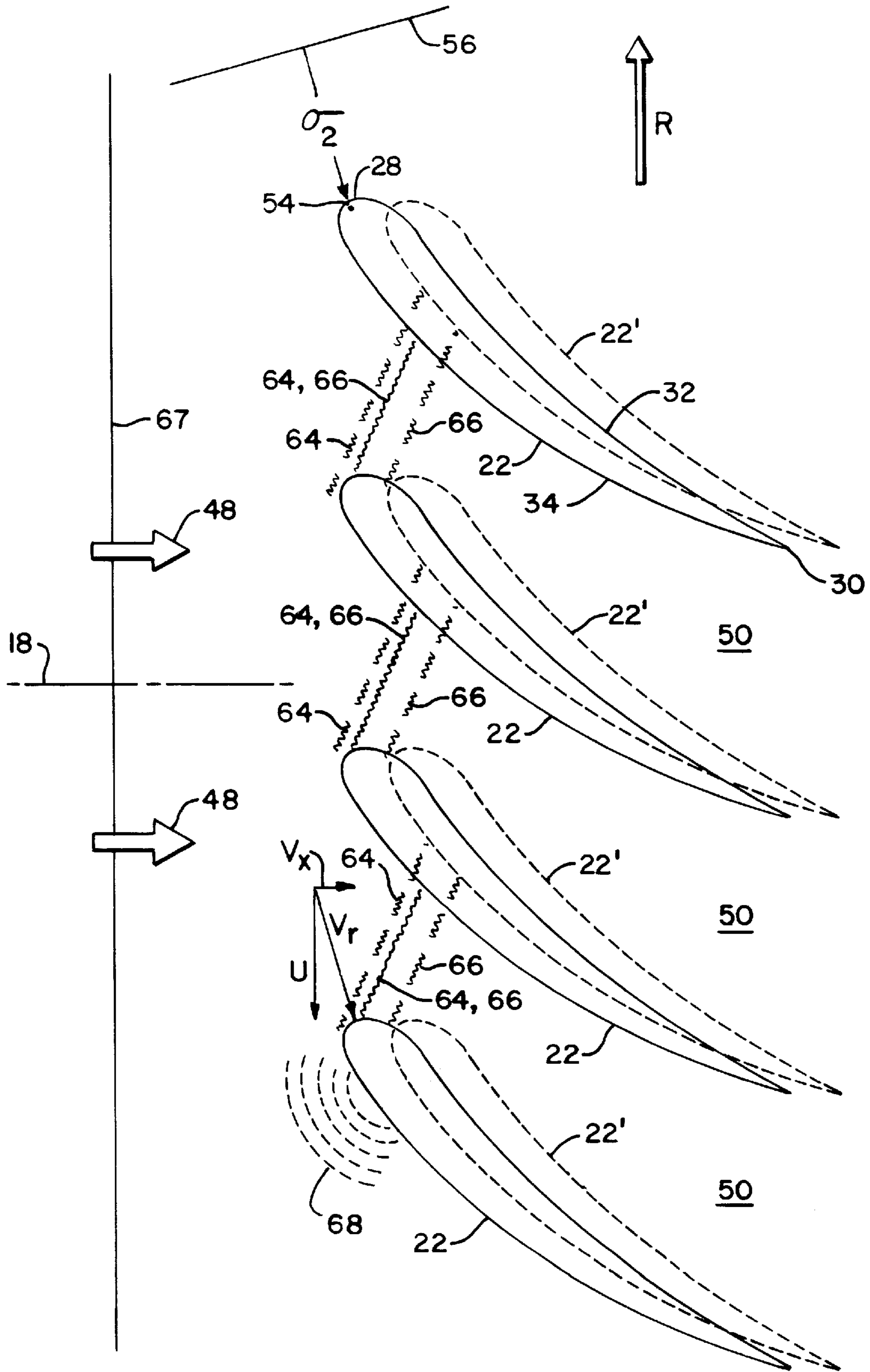

FIG. 3

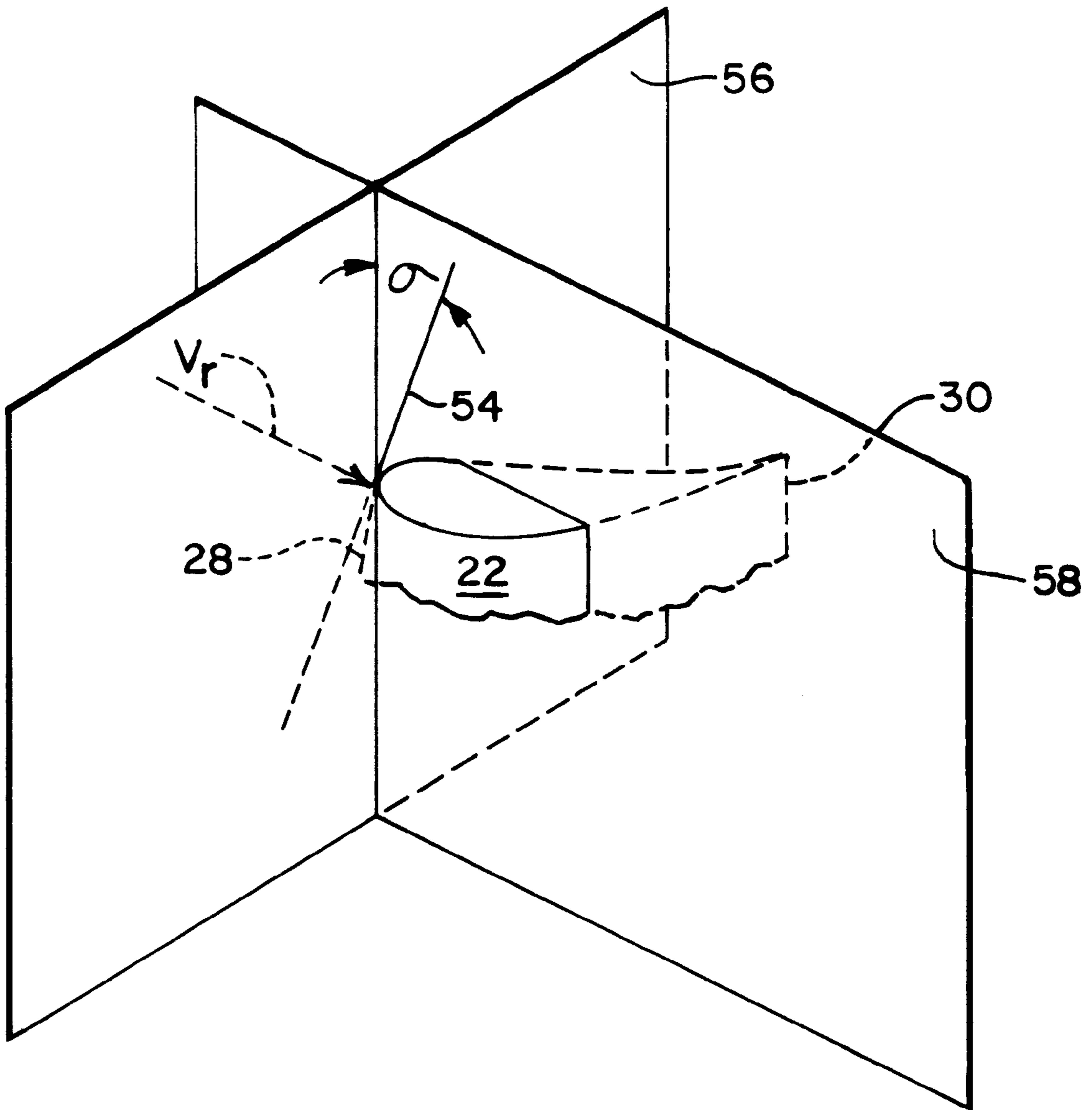

FIG. 4

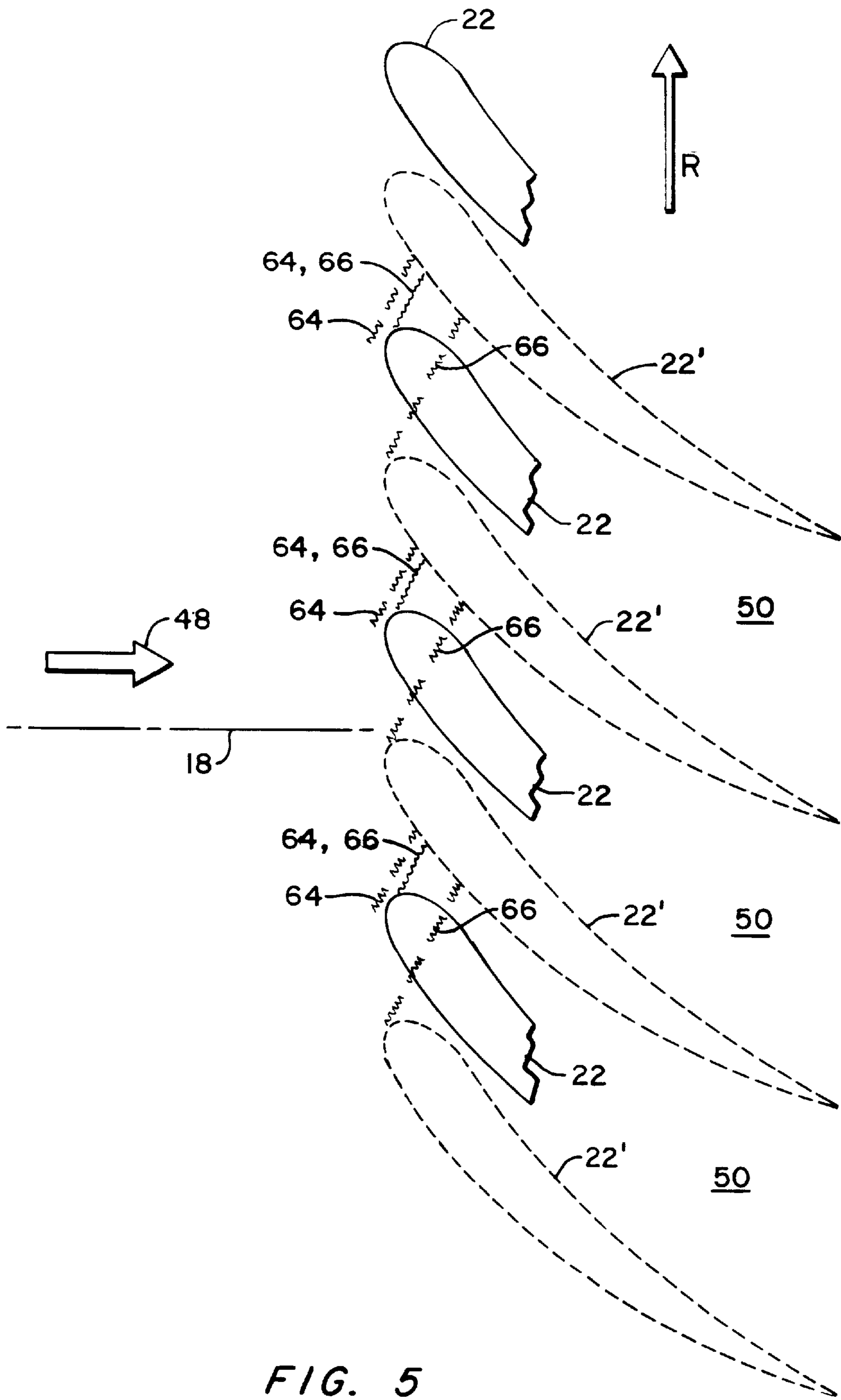
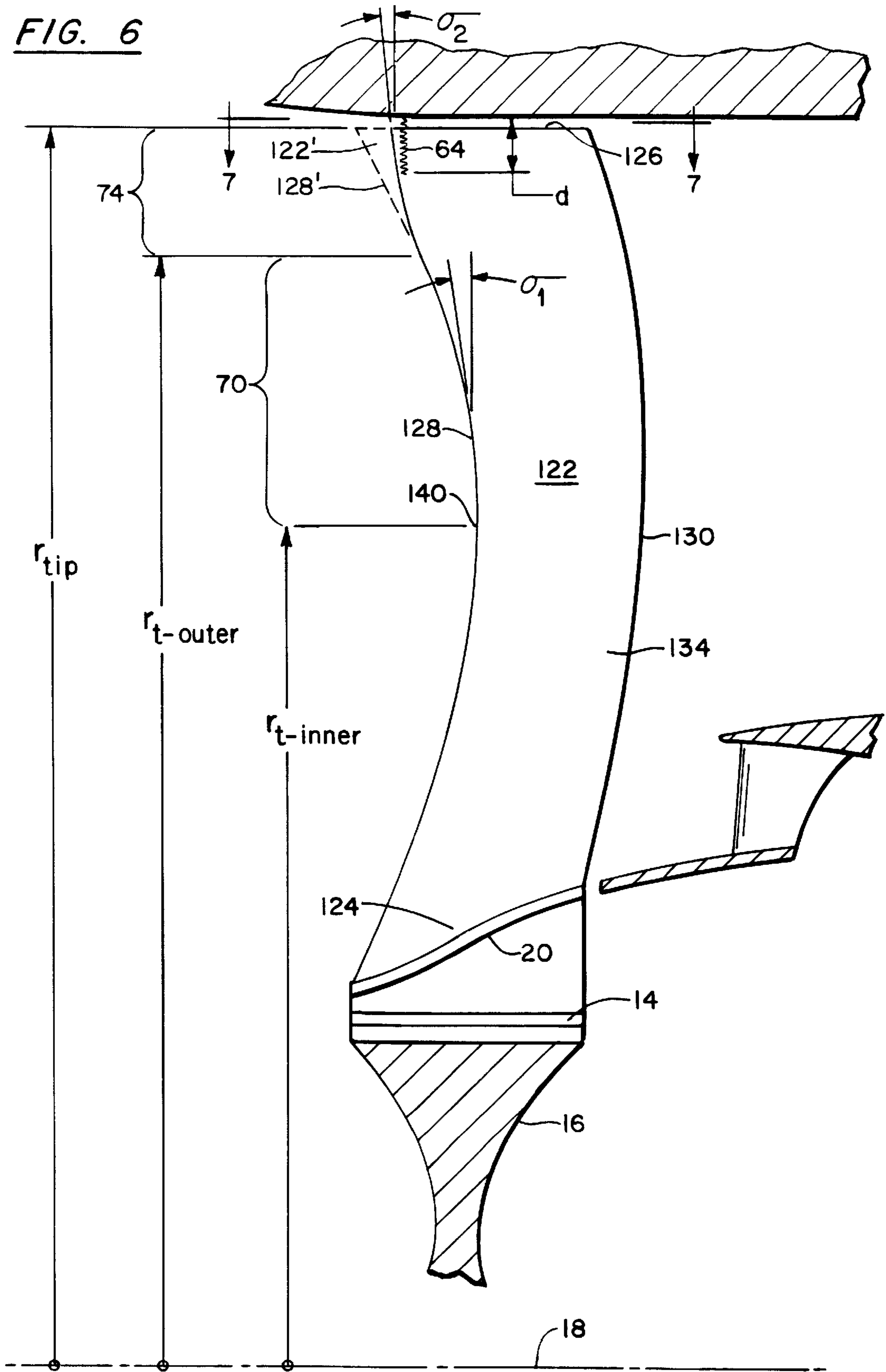

FIG. 5

FIG. 6



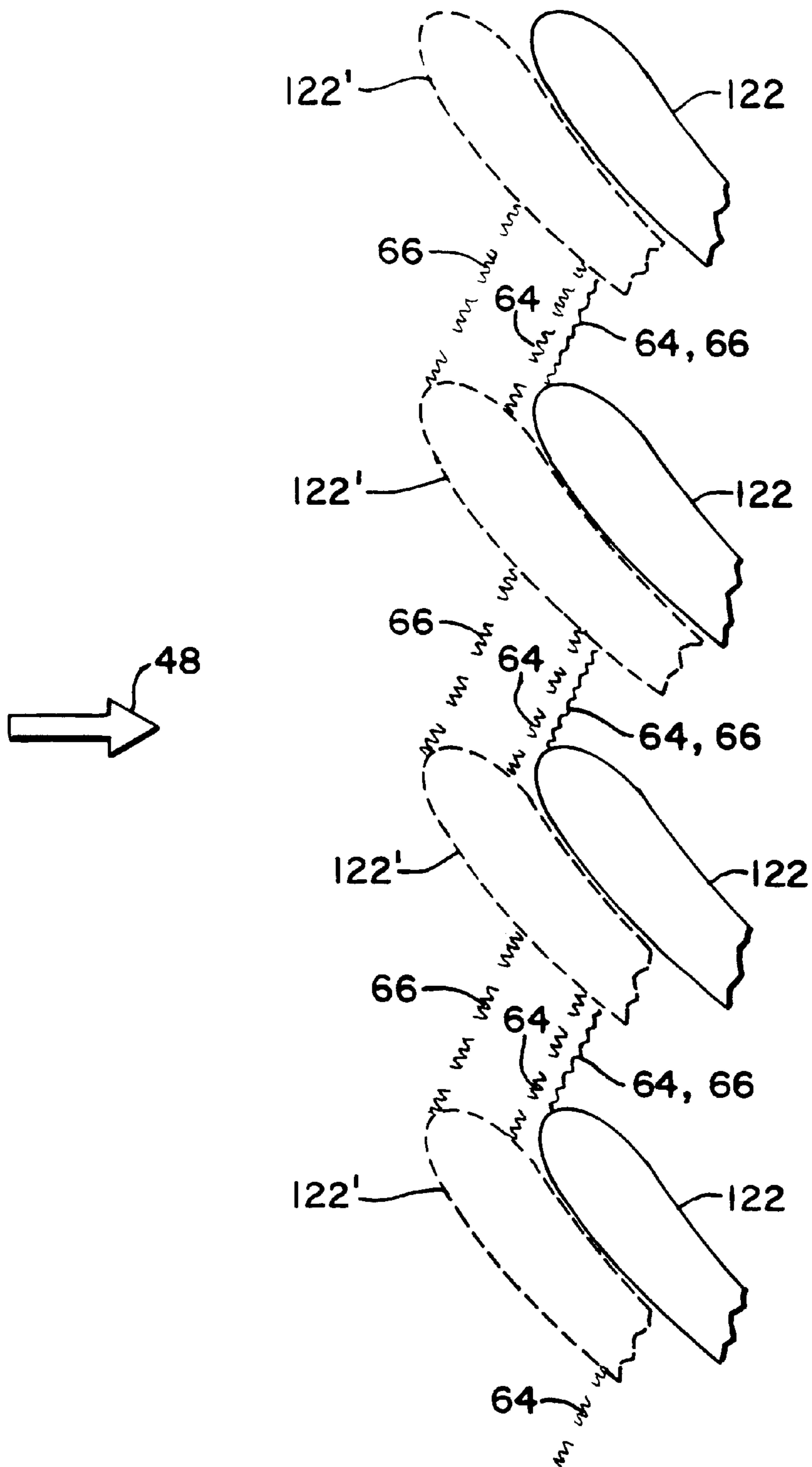

FIG. 7

SWEPT TURBOMACHINERY BLADE

Matter enclosed in heavy brackets [] appears in the original patent but forms no part of this reissue specification; matter printed in italics indicates the additions made by reissue.

CROSS REFERENCE TO RELATED REISSUE APPLICATIONS

This is the parent of a continuation reissue application filed on Jun. 5, 2001, and accorded application Ser. No. 09/874,931.

STATEMENT REGARDING GOVERNMENT RIGHTS

The government has certain rights to this invention under Department of Defense Contract No. N00140-91-C-2793.

TECHNICAL FIELD

This invention relates to turbomachinery blades, and particularly to blades whose airfoils are swept to minimize the adverse effects of supersonic flow of a working medium over the airfoil surfaces.

BACKGROUND OF THE INVENTION

Gas turbine engines employ cascades of blades to exchange energy with a compressible working medium gas that flows axially through the engine. Each blade in the cascade has an attachment which engages a slot in a rotatable hub so that the blades extend radially outward from the hub. Each blade has a radially extending airfoil, and each airfoil cooperates with the airfoils of the neighboring blades to define a series of interblade flow passages through the cascade. The radially outer boundary of the flow passages is formed by a case which circumscribes the airfoil tips. The radially inner boundary of the passages is formed by abutting platforms which extend circumferentially from each blade.

During engine operation the hub, and therefore the blades attached thereto, rotate about a longitudinally extending rotational axis. The velocity of the working medium relative to the blades increases with increasing radius. Accordingly, it is not uncommon for the airfoil leading edges to be swept forward or swept back to mitigate the adverse aerodynamic effects associated with the compressibility of the working medium at high velocities.

One disadvantage of a swept blade results from pressure waves which extend along the span of each airfoil suction surface and reflect off the surrounding case. Because the airfoil is swept, both the incident waves and the reflected waves are oblique to the case. The reflected waves interact with the incident waves and coalesce into a planar aerodynamic shock which extends across the interblade flow channel between neighboring airfoils. These "endwall shocks" extend radially inward a limited distance from the case. In addition, the compressibility of the working medium causes a passage shock, which is unrelated to the above described endwall shock, to extend across the passage from the leading edge of each blade to the suction surface of the adjacent blade. As a result, the working medium gas flowing into the channels encounters multiple shocks and experiences unrecoverable losses in velocity and total pressure, both of which degrade the engine's efficiency. What is needed is a turbomachinery blade whose airfoil is swept to mitigate the effects of working medium compressibility while also avoiding the adverse influences of multiple shocks.

DISCLOSURE OF THE INVENTION

It is therefore an object of the invention to minimize the aerodynamic losses and efficiency degradation associated with endwall shocks by limiting the number of shocks in each interblade passage.

According to the invention, a blade for a blade cascade has an airfoil which is swept over at least a portion of its span, and the section of the airfoil radially coextensive with the endwall shock intercepts the endwall shock extending from the neighboring airfoil so that the endwall shock and the passage shock are coincident.

In one embodiment the axially forwardmost extremity of the airfoil's leading edge defines an inner transition point located at an inner transition radius radially inward of the airfoil tip. An outer transition point is located at an outer transition radius radially intermediate the inner transition radius and the airfoil tip. The outer transition radius and the tip bound a blade tip region while the inner and outer transition radii bound an intermediate region. The leading edge is swept at a first sweep angle in the intermediate region and is swept at a second sweep angle over at least a portion of the tip region. The first sweep angle is generally nondecreasing with increasing radius and the second sweep angle is generally non-increasing with increasing radius.

The invention has the advantage of limiting the number of shocks in each interblade passage so that engine efficiency is maximized.

BRIEF DESCRIPTION OF THE DRAWINGS

FIG. 1 is a cross sectional side elevation of the fan section of a gas turbine engine showing a swept back fan blade according to the present invention.

FIG. 2 is an enlarged view of the blade of FIG. 1 including an alternative leading edge profile shown by dotted lines and a prior art blade shown in phantom.

FIG. 3 is a developed view taken along the line 3—3 of FIG. 2 illustrating the tips of four blades of the present invention along with four prior art blades shown in phantom.

FIG. 4 is a schematic perspective view of an airfoil fragment illustrating the definition of sweep angle.

FIG. 5 is a developed view similar to FIG. 3 illustrating an alternative embodiment of the invention and showing prior art blades in phantom.

FIG. 6 is a cross sectional side elevation of the fan section of a gas turbine engine showing a forward swept fan blade according to the present invention and showing a prior art fan blade in phantom.

FIG. 7 is a developed view taken along the line 7—7 of FIG. 6 illustrating the tips of four blades of the present invention along with four prior art blades shown in phantom.

BEST MODE FOR CARRYING OUT THE INVENTION

Referring to FIGS. 1—3, the forward end of a gas turbine engine includes a fan section 10 having a cascade of fan blades 12. Each blade has an attachment 14 for attaching the blade to a disk or hub 16 which is rotatable about a longitudinally extending rotational axis 18. Each blade also has a circumferentially extending platform 20 radially outward of the attachment. When installed in an engine, the platforms of neighboring blades in the cascade abut each other to form the cascade's inner flowpath boundary. An airfoil 22 extending radially outward from each platform has a root 24, a tip 26, a leading edge 28, a trailing edge 30, a

pressure surface **32** and a suction surface **34**. The axially forwardmost extremity of the leading edge defines an inner transition point **40** at an inner transition radius $r_{t\text{-inner}}$, radially inward of the tip. The blade cascade is circumscribed by a case **42** which forms the cascade's outer flowpath boundary. The case includes a rubstrip **46** which partially abrades away in the event that a rotating blade contacts the case during engine operation. A working medium fluid such as air **48** is pressurized as it flows axially through interblade passages **50** between neighboring airfoils.

The hub **16** is attached to a shaft **52**. During engine operation, a turbine (not shown) rotates the shaft, and therefore the hub and the blades, about the axis **18** in direction **R**. Each blade, therefore, has a leading neighbor which precedes it and a trailing neighbor which follows it during rotation of the blades about the rotational axis.

The axial velocity V_x (FIG. **3**) of the working medium is substantially constant across the radius of the flowpath. However the linear velocity U of a rotating airfoil increases with increasing radius. Accordingly, the relative velocity V_r of the working medium at the airfoil leading edge increases with increasing radius, and at high enough rotational speeds, the airfoil experiences supersonic working medium flow velocities in the vicinity of its tip. Supersonic flow over an airfoil, while beneficial for maximizing the pressurization of the working medium, has the undesirable effect of reducing fan efficiency by introducing losses in the working medium's velocity and total pressure. Therefore, it is typical to sweep the airfoil's leading edge over at least a portion of the blade span so that the working medium velocity component in the chordwise direction (perpendicular to the leading edge) is subsonic. Since the relative velocity V_r increases with increasing radius, the sweep angle typically increases with increasing radius as well. As shown in FIG. **4**, the sweep angle σ at any arbitrary radius is the acute angle between a line **54** tangent to the leading edge **28** of the airfoil **22** and a plane **56** perpendicular to the relative velocity vector V_r . The sweep angle is measured in plane **58** which contains both the relative velocity vector and the tangent line and is perpendicular to plane **56**. In conformance with this definition sweep angles σ_1 and σ_2 , referred to hereinafter and illustrated in FIGS. **2**, **3** and **6** are shown as projections of the actual sweep angle onto the plane of the illustrations.

Sweeping the blade leading edge, while useful for minimizing the adverse effects of supersonic working medium velocity, has the undesirable side effect of creating an endwall reflection shock. The flow of the working medium over the blade suction surface generates pressure waves **60** (shown only in FIG. **1**) which extend along the span of the blade and reflect off the case. The reflected waves **62** and the incident waves **60** coalesce in the vicinity of the case to form an endwall shock **64** across each interblade passage. The endwall shock extends radially inward a limited distance, d , from the case. As best seen in the prior art (phantom) illustration of FIG. **3**, each endwall shock is also oblique to a plane **67** perpendicular to the rotational axis so that the shock extends axially and circumferentially. In principle, an endwall shock can extend across multiple interblade passages and affect the working medium entering those passages. In practice, expansion waves (as illustrated by the representative waves **68**) propagate axially forward from each airfoil and weaken the endwall shock from the airfoil's leading neighbor so that each endwall shock usually affects only the passage wherein the endwall shock originated. In addition, the supersonic character of the flow causes passage shocks **66** to extend across the passages. The passage

shocks, which are unrelated to endwall reflections, extend from the leading edge of each blade to the suction surface of the blade's leading neighbor. Thus, the working medium is subjected to the aerodynamic losses of multiple shocks with a corresponding degradation of engine efficiency.

The endwall shock can be eliminated by making the case wall perpendicular to the incident expansion waves so that the incident waves coincide with their reflections. However other design considerations, such as constraints on the flowpath area and limitations on the case construction, may make this option unattractive or unavailable. In circumstances where the endwall shock cannot be eliminated, it is desirable for the endwall shock to coincide with the passage shock since the aerodynamic penalty of coincident shocks is less than that of multiple individual shocks.

According to the present invention, coincidence of the endwall shock and the passage shock is achieved by uniquely shaping the airfoil so that the airfoil intercepts the endwall shock extending from the airfoil's leading neighbor and results in coincidence between the endwall shock and the passage shock.

A swept back airfoil according to the present invention has a leading edge **28**, a trailing edge **30**, a root **24** and a tip **26** located at a tip radius r_{tip} . An inner transition point **40** located at an inner transition radius $r_{t\text{-inner}}$ is the axially forwardmost point on the leading edge. The leading edge of the airfoil is swept back by a radially varying first sweep angle σ_1 in an intermediate region **70** of the airfoil (in FIG. **2** plane **56** appears as the line defined by the plane's intersection with the plane of the illustration and in FIG. **3** the tangent line **54** appears as the point where the tangent line penetrates the plane of the Figure). The intermediate region **70** is the region radially bounded by the inner transition radius $r_{t\text{-inner}}$ and the outer transition radius $r_{t\text{-outer}}$. The first sweep angle, as is customary in the art, is nondecreasing with increasing radius, i.e. the sweep angle increases, or at least does not decrease, with increasing radius.

The leading edge **28** of the airfoil is also swept back by a radially varying second sweep angle σ_2 in a tip region **74** of the airfoil. The tip region is radially bounded by the outer transition radius $r_{t\text{-outer}}$ and a tip radius r_{tip} . The second sweep angle is nonincreasing (decreases, or at least does not increase) with increasing radius. This is in sharp contrast to the prior art airfoil **22'** whose sweep angle increases with increasing radius radially outward of the inner transition radius.

The beneficial effect of the invention is appreciated primarily by reference to FIG. **3** which compares the invention (and the associated endwall and passage shocks) to a prior art blade (and its associated shocks) shown in phantom. Referring first to the prior art illustration in phantom, the endwall shock **64** originates as a result of the pressure waves **60** (FIG. **1**) extending along the suction surface of each blade. Each endwall shock is oblique to a plane **67** perpendicular to the rotational axis, and extends across the interblade passage of origin. The passage shock **66** also extends across the flow passage from the leading edge of a blade to the suction surface of the blade's leading neighbor. The working medium entering the passages is therefore adversely influenced by multiple shocks. By contrast, the nonincreasing character of the second sweep angle of a swept back airfoil **22** according to the invention causes a portion of the airfoil leading edge to be far enough forward (upstream) in the working medium flow that the section of the airfoil radially coextensive with the endwall shock

extending from the airfoil's leading neighbor intercepts the endwall shock **64** (the unique sweep of the airfoil does not appreciably affect the location or orientation of the endwall shock; the phantom endwall shock associated with the prior art blade is illustrated slightly upstream of the endwall shock for the airfoil of the invention for illustrative clarity). In addition, the passage shock **66** (which remains attached to the airfoil leading edge and therefore is translated forward along with the leading edge) is brought into coincidence with the endwall shock so that the working medium does not encounter multiple shocks.

The embodiment of FIGS. **2** and **3** illustrates a blade whose leading edge, in comparison to the leading edge of a conventional blade, has been translated axially forward parallel to the rotational axis (the corresponding translation of the trailing edge is an illustrative convenience—the location of the trailing edge is not embraced by the invention). However the invention contemplates any blade whose airfoil intercepts the endwall shock to bring the passage shock into coincidence with the endwall shock. For example, FIG. **5** illustrates an embodiment where a section of the tip region is displaced circumferentially (relative to the prior art blade) so that the blade intercepts the endwall shock **64** and brings it into coincidence with the passage shock **66**. As with the embodiment of FIG. **3**, the displaced section extends radially inward far enough to intercept the endwall shock over its entire radial extent and brings it into coincidence with the passage shock **66**. This embodiment functions as effectively as the embodiment of FIG. **3** in terms of bringing the passage shock into coincidence with the endwall shock. However it suffers from the disadvantage that the airfoil tip is curled in the direction of rotation **R**. In the event that the blade tip contacts the rubstrip **46** during engine operation, the curled blade tip will gouge rather than abrade the rubstrip necessitating its replacement. Other alternative embodiments may also suffer from this or other disadvantages.

The invention's beneficial effects also apply to a blade having a forward swept airfoil. Referring to FIG. **6** and **7**, a forward swept airfoil **122** according to the present invention has a leading edge **128**, a trailing edge **130**, a root **124** and a tip **126** located at a tip radius r_{tip} . An inner transition point **140** located at an inner transition radius $r_{t-inner}$ is the axially aftmost point on the leading edge. The leading edge of the airfoil is swept forward by a radially varying first sweep angle σ_1 in an intermediate region **70** of the airfoil. The intermediate region is radially bounded by the inner transition radius $r_{t-inner}$ and the outer transition radius $r_{t-outer}$. The first sweep angle $[\tau_1] \sigma_1$ is nondecreasing with increasing radius, i.e. the sweep angle increases, or at least does not decrease, with increasing radius.

The leading edge **128** of the airfoil is also swept forward by a radially varying second sweep angle σ_2 in a tip region **74** of the airfoil. The tip region is radially bounded by the outer transition radius $r_{t-outer}$ and the tip radius r_{tip} . The second sweep angle is nonincreasing (decreases, or at least does not increase) with increasing radius. This is in sharp contrast to the prior art airfoil **122'** whose sweep angle increases with increasing radius radially outward of the inner transition radius.

In the forward swept embodiment of the invention, as in the swept back embodiment, the nonincreasing sweep angle σ_2 in the tip region **74** causes the endwall shock **64** to be coincident with the passage shock **66** for reducing the aerodynamic losses as discussed previously. This is in contrast to the prior art blade, shown in phantom where the endwall shock and the passage shock are distinct and therefore impose multiple aerodynamic losses on the working medium.

In the swept back embodiment of FIG. **2**, the inner transition point is the axially forwardmost point on the leading edge. The leading edge is swept back at radii greater than the inner transition radius. The character of the leading edge sweep inward of the inner transition radius is not embraced by the invention. In the forward swept embodiment of FIG. **6**, the inner transition point is the axially aftmost point on the leading edge. The leading edge is swept forward at radii greater than the inner transition radius. As with the swept back embodiment, the character of the leading edge sweep inward of the inner transition radius is not embraced by the invention. In both the forward swept and back swept embodiments, the inner transition point is illustrated as being radially outward of the airfoil root. However the invention also comprehends a blade whose inner transition point (axially forwardmost point for the swept back embodiment and axially aftmost point for the forward swept embodiment) is radially coincident with the leading edge of the root. This is shown, for example, by the dotted leading edge **28''** of FIG. **2**.

The invention has been presented in the context of a fan blade for a gas turbine engine, however, the invention's applicability extends to any turbomachinery airfoil wherein flow passages between neighboring airfoils are subjected to multiple shocks.

We claim:

1. A turbomachinery blade for a turbine engine having a cascade of blades rotatable about a rotational axis so that each blade in the cascade has a leading neighbor and a trailing neighbor, and each blade cooperates with its neighbors to define flow passages for a working medium gas, the blade cascade being circumscribed by a case and under some operational conditions an endwall shock extends a limited distance radially inward from the case and also extends axially and circumferentially across the flow passages, and a passage shock also extends across the flow passages, the turbomachinery blade including an airfoil having a leading edge, a trailing edge, a root, a tip and an inner transition point located at an inner transition radius radially inward of the tip, the blade characterized in that at least a portion of the leading edge radially outward of the inner transition point is swept and a section of the airfoil radially coextensive with the endwall shock extending from the leading neighbor intercepts the endwall shock so that the endwall shock and the passage shock are coincident.

2. A turbomachinery blade for a turbine engine having a cascade of blades rotatable about a rotational axis so that each blade in the cascade has a leading neighbor and a trailing neighbor, and each blade cooperates with its neighbors to define flow passages for a working medium gas, the blade cascade being circumscribed by a case and under some operational conditions an endwall shock extends a limited distance radially inward from the case and also extends axially and circumferentially across the flow passages and a passage shock also extends across the flow passages, the turbomachinery blade including an airfoil having a leading edge, a trailing edge, a root, a tip located at a tip radius, an inner transition point located at an inner transition radius radially inward of the tip, and an outer transition point at an outer transition radius radially intermediate the inner transition radius and the tip radius, the blade having a tip region bounded by the outer transition radius and the tip radius, and an intermediate region bounded by the inner transition radius and the outer transition radius, the blade characterized in that the leading edge is swept in the intermediate region at a first sweep angle which is generally nondecreasing with increasing radius, and the leading edge is swept over at least

a portion of the tip region at a second sweep angle which is generally nonincreasing with increasing radius so that the section of the airfoil radially coextensive with the endwall shock extending from the leading neighbor intercepts the endwall shock so that the endwall shock and the passage shock are coincident.

3. The turbomachinery blade of claim 1 or 2 characterized in that the inner transition radius is coincident with the root at the leading edge of the blade.

4. A turbomachinery blade for a gas turbine engine fan comprising a plurality of blades mounted for rotation about a fan axis with neighboring blades forming passages for a working medium gas, wherein:

the blade has a configuration enabling the fan to rotate at speeds providing supersonic flow velocities over the blade in at least a portion of each passage causing the formation of a shock in the gas adjacent an inner wall of a case forming an outer boundary for the working medium gas flowing through the passages;

the blade has a leading edge with an inner region ending at an inward boundary of an intermediate region and a tip region beginning at an outward boundary of the intermediate region and extending to a tip end of the blade, the inner region being swept forward and the intermediate region being swept rearward at a sweep angle that does not decrease; and

the tip region is translated forward relative to a leading edge with the same sweep angle as the outward boundary of the intermediate region, to provide a sweep angle that causes the blade to intercept the shock.

5. The turbomachinery blade of claim 4, wherein throughout the tip region the sweep angle is less than the sweep angle at the outward boundary of the intermediate region.

6. The turbomachinery blade of claim 5, wherein the sweep angle decreases throughout the tip region.

7. The turbomachinery blade of claim 6, wherein the sweep angle increases throughout the intermediate region.

8. The turbomachinery blade of any one of claims 4 to 7, wherein the inner region extends between a root end of the blade and the inward boundary of the intermediate region, and the entire inner region is swept forward.

9. A blade for a gas turbine engine fan comprising a plurality of blades mounted for rotation within a case circumscribing the blades and forming an outer boundary for a working medium gas flowing through passages formed by neighboring blades, wherein:

the blade has a configuration enabling the fan to rotate at speeds providing supersonic flow velocities over the blade in at least a portion of each passage;

the blade has a leading edge with an inner region ending at an inward boundary of an intermediate region and a tip region beginning at an outward boundary of the intermediate region and extending to a tip end of the blade, the inner region being swept forward and the intermediate region being swept rearward at a sweep angle that does not decrease from the inward boundary of the intermediate region to the outward boundary of the intermediate region; and

throughout the tip region the sweep angle is less than the sweep angle at the outward boundary of the intermediate region.

10. The blade of claim 9, wherein the tip region is translated forward relative to a leading edge with the same sweep angle as the outward boundary of the intermediate region.

11. The blade of claim 10, wherein the inner region extends between a root end of the blade and the inward

boundary of the intermediate region, and the entire inner region is swept forward.

12. The blade of claim 11, wherein:

the intermediate region sweep angle increases throughout the intermediate region; and

the tip region sweep angle decreases throughout the tip region.

13. The blade of claim 10, wherein the tip region sweep angle decreases throughout the tip region.

14. The blade of claim 13, wherein the intermediate region sweep angle increases throughout the intermediate region.

15. The blade of claim 9, wherein the tip region maintains a rearward sweep throughout the tip region.

16. A gas turbine engine fan, comprising a plurality of blades mounted for rotation within a case circumscribing the blades and forming an outer boundary for a working medium gas flowing through passages formed by neighboring blades, wherein:

each blade has a configuration enabling the fan to rotate at speeds providing supersonic working medium gas velocities over the blade at least in the vicinity of the passage proximate to the case;

each blade has a leading edge with an inner region ending at an inward boundary of a swept intermediate region and a swept tip region beginning at an outward boundary of the intermediate region and extending to a tip end of the blade, the inner region of each blade being swept forward and the intermediate region of each blade being swept rearward at a sweep angle that does not decrease from the inward boundary of the intermediate region to the outward boundary of the intermediate region; and

throughout the tip region the sweep angle of each blade is less than the sweep angle at the outward boundary of the intermediate region.

17. The gas turbine engine fan of claim 16, wherein the tip region is translated forward relative to a leading edge with the same sweep angle as the outward boundary of the intermediate region.

18. The gas turbine engine fan of claim 17, wherein:
the intermediate region sweep angle of each blade increases throughout the intermediate region; and
the tip region sweep angle of each blade decreases throughout the tip region.

19. The gas turbine engine fan of claim 18, wherein the inner region of the leading edge of each blade begins at a root end of the blade and extends to the inward boundary of the intermediate region, and the entire inner region of each blade is swept forward.

20. A gas turbine engine fan comprising a plurality of identical blades, each blade being mounted for rotation within a case circumscribing the blades and having an inner wall forming an outer boundary for a working medium gas flowing through passages formed by neighboring blades, wherein:

each blade has a configuration enabling the fan to rotate at speeds providing supersonic working medium gas velocities over the blade in the vicinity of the passages proximate to the case;

each blade has a leading edge with an inner region, an intermediate region and a tip region, the inner region extending to an inward boundary of the intermediate region, and the tip region extending from an outward boundary of the intermediate region to a tip end of the blade; and

the inner region is swept forward, the intermediate region is swept rearward at a sweep angle that does not decrease, and the tip region is translated forward relative to a leading edge with the same sweep angle as the outward boundary of the intermediate region.

21. *The gas turbine engine fan of claim 20, wherein the tip region maintains a rearward sweep throughout the tip region.*

22. *The gas turbine engine fan of claim 20, wherein:*

the intermediate region sweep angle of each blade increases throughout the intermediate region; and the tip region of each blade is swept at a sweep angle that decreases throughout the tip region.

23. *The gas turbine engine fan of claim 20, wherein the inner wall of the case is perpendicular to pressure waves that extend spanwise of the blades as they rotate, the waves being incident to the case wall in a region of the blades.*

24. *The gas turbine engine fan of claim 20, wherein a projection of the tip end of each blade onto a radial plane is parallel to the inner wall of the casing in longitudinal cross-section.*

25. *The gas turbine engine fan of claim 20, wherein the inner region of the leading edge of each blade begins at a root end of the blade, and the entire inner region of each blade is swept forward.*

26. *A blade for a gas turbine engine rotatable within a case at speeds providing supersonic flow over at least a portion of the blade, wherein the blade has a leading edge with a forward swept inner region, the inner region ending at a rearward swept middle region having a sweep angle that does not decrease throughout the middle region, the middle region ending at a tip region that is translated forward relative to a leading edge with the same sweep angle as the end of the middle region.*

27. *The blade of claim 26, wherein the tip region maintains a rearward sweep throughout the tip region.*

28. *The blade of claim 26, wherein the inner region extends from a blade root to the middle region and the leading edge is swept forward throughout the inner region.*

29. *The blade of claim 28, wherein the sweep angle of the middle region increases throughout the middle region.*

30. *The blade of claim 29, wherein throughout the tip region the sweep angle is less than the sweep angle at the end of the middle region.*

31. *The blade of claim 30, wherein the sweep angle of the tip region decreases from the end of the middle region to a tip end of the blade.*

32. *A blade for a gas turbine engine rotatable within a case at speeds providing supersonic flow over at least a portion of the blade, wherein the blade has a leading edge with a forward swept middle region having a sweep angle that does not decrease throughout the middle region and ending at a tip region that is translated rearward relative to a leading edge with the same sweep angle as the end of the middle region.*

33. *The blade of claim 32, wherein the tip region maintains a forward sweep throughout the tip region.*

34. *The blade of claim 32, wherein the leading edge has a rear swept inner region.*

35. *The blade of claim 34, wherein the sweep angle of the middle region increases throughout the middle region.*

36. *The blade of claim 35, wherein throughout the tip region the sweep angle is less than the sweep angle at the end of the middle region.*

37. *The blade of claim 36, wherein the sweep angle of the tip region decreases from the end of the middle region to a tip end of the blade.*

* * * * *