



US00RE37743E

(19) **United States**
(12) **Reissued Patent**
Yang

(10) **Patent Number: US RE37,743 E**
(45) **Date of Reissued Patent: Jun. 11, 2002**

(54) **DISTRIBUTED DIFFERENTIAL MIXING
COMBINED POWER SYSTEM**

(76) **Inventor: Tai-Her Yang**, No. 32, Lane 29, Taipin
St., Si-Hu Town, Dzan-Hwa (TW)

(21) **Appl. No.: 09/580,967**

(22) **Filed: May 30, 2000**

Related U.S. Patent Documents

Reissue of:

(64) **Patent No.: 5,562,566**
Issued: Oct. 8, 1996
Appl. No.: 08/317,633
Filed: Oct. 3, 1994

(51) **Int. Cl.⁷ B60K 1/02**

(52) **U.S. Cl. 477/3; 475/5; 180/65.2;**
180/65.6

(58) **Field of Search 477/3; 475/1, 5;**
180/65.2, 65.3, 65.4, 65.6, 65.7

(56) **References Cited**

U.S. PATENT DOCUMENTS

4,309,620	A	*	1/1982	Bock	180/65.2
4,405,029	A	*	9/1983	Hunt	180/65.2
5,120,282	A	*	6/1992	Fjallstrom	475/5
5,327,987	A	*	7/1994	Abdelmalek	180/65.2
5,346,031	A	*	9/1994	Gardner	180/64.2

* cited by examiner

Primary Examiner—Dirk Wright
(74) *Attorney, Agent, or Firm*—Bacon & Thomas

(57) **ABSTRACT**

A drive side power unit, which may include the rotational output shaft of an internal combustion engine, drives a front section load, and is also coupled to a differential drive device made up of an electrical machine and a rear differential gear box. The electrical machine is coupled, via a transmission gear, to two differential output shafts and an input shaft, while the two wheel shafts of the differential gears are respectively coupled with a transmission middle shaft driven by the drive side rotational power unit and with the input shaft of the rear differential gear box through a clutch so as to drive a rear section load. Alternatively, the three end shaft differential gear system can be replaced by a planetary gear train and the transmission gear can be replaced by a friction wheel. A brake installed between the rotor and stator of the electrical machine can be controlled to generate motor driving functions when an input current is applied or to generate variable speed coupling functions through an output current when the electrical machine is employed as a generator. The engine can be operated at constant speed or at a partially adjustable speed to maximize engine efficiency and reduce pollution, with one part of the differential speed output power generated throughout the differential mixing drive device being used for driving the load while the remainder of the power is converted through the generator function of the electrical machine to charge the battery and thereby increase energy efficiency.

23 Claims, 8 Drawing Sheets

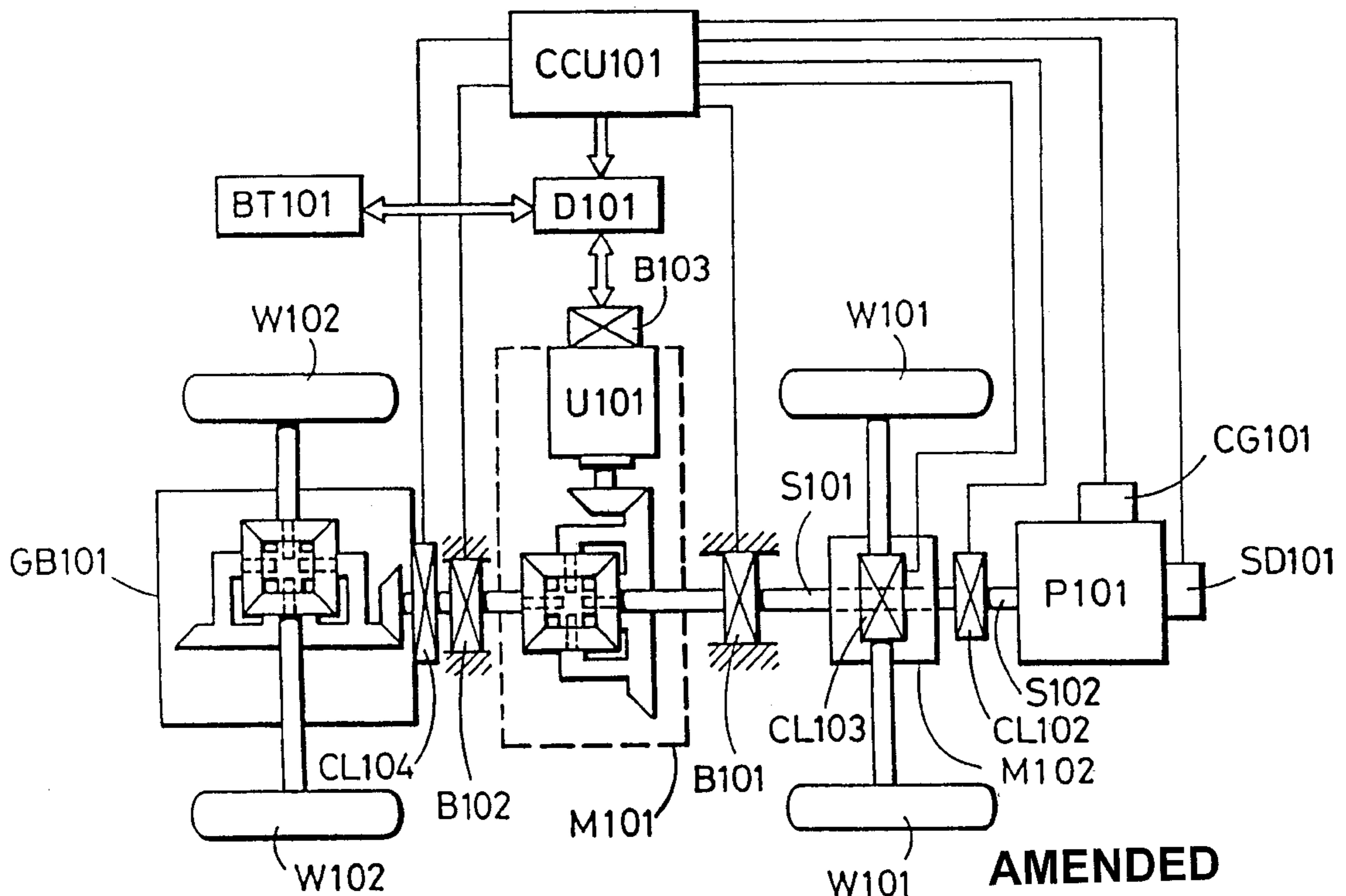

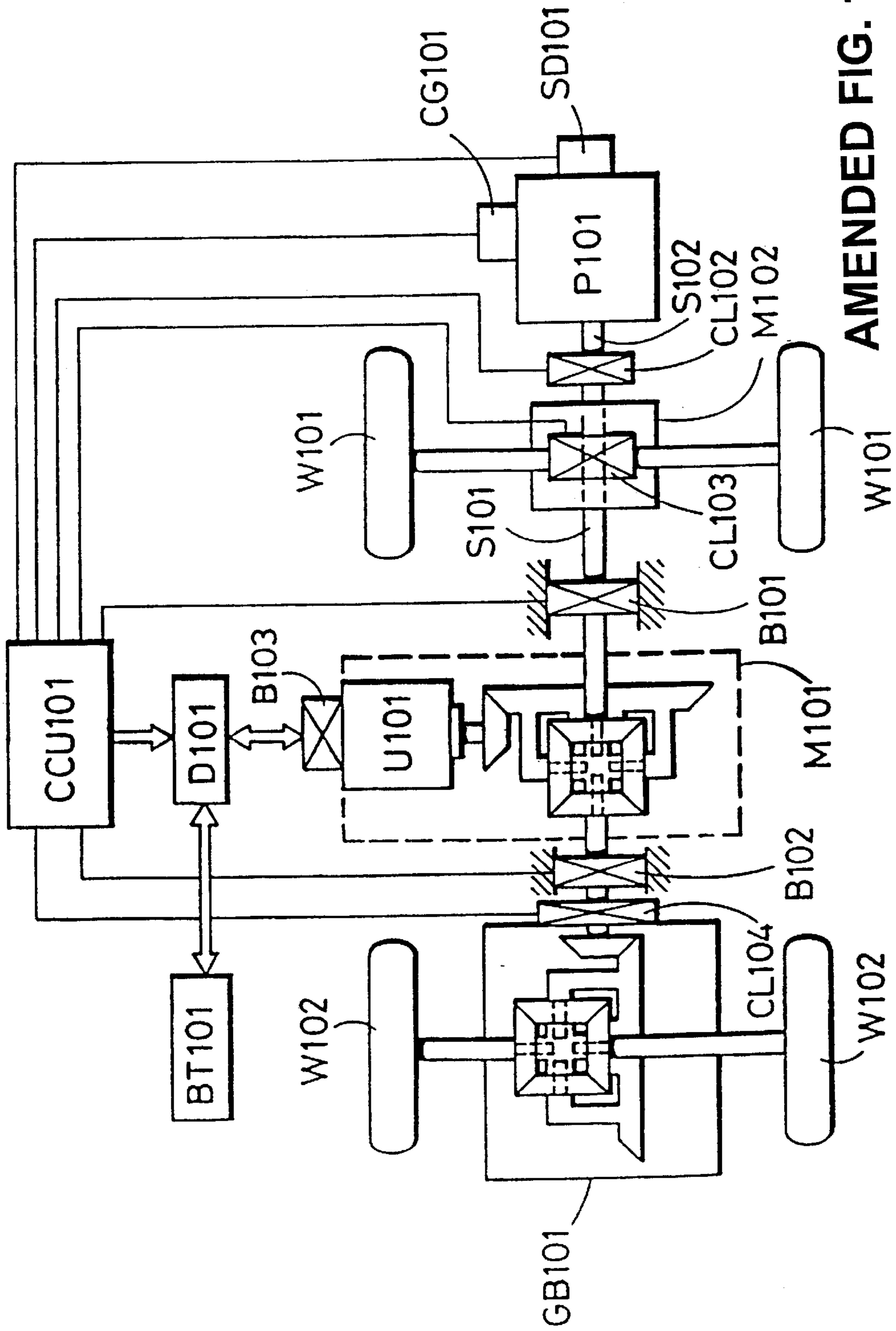

AMENDED FIG. 1

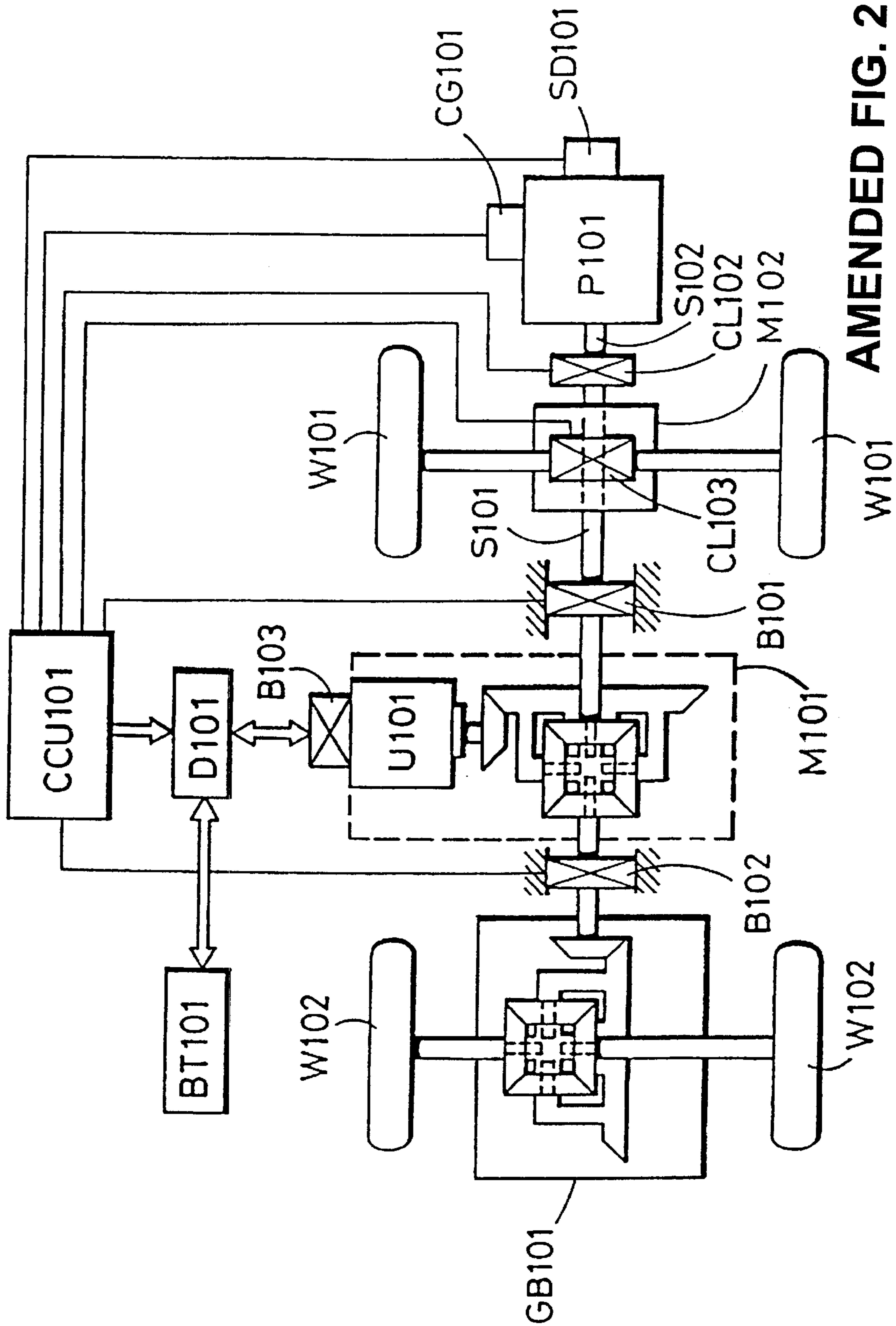

AMENDED FIG. 2

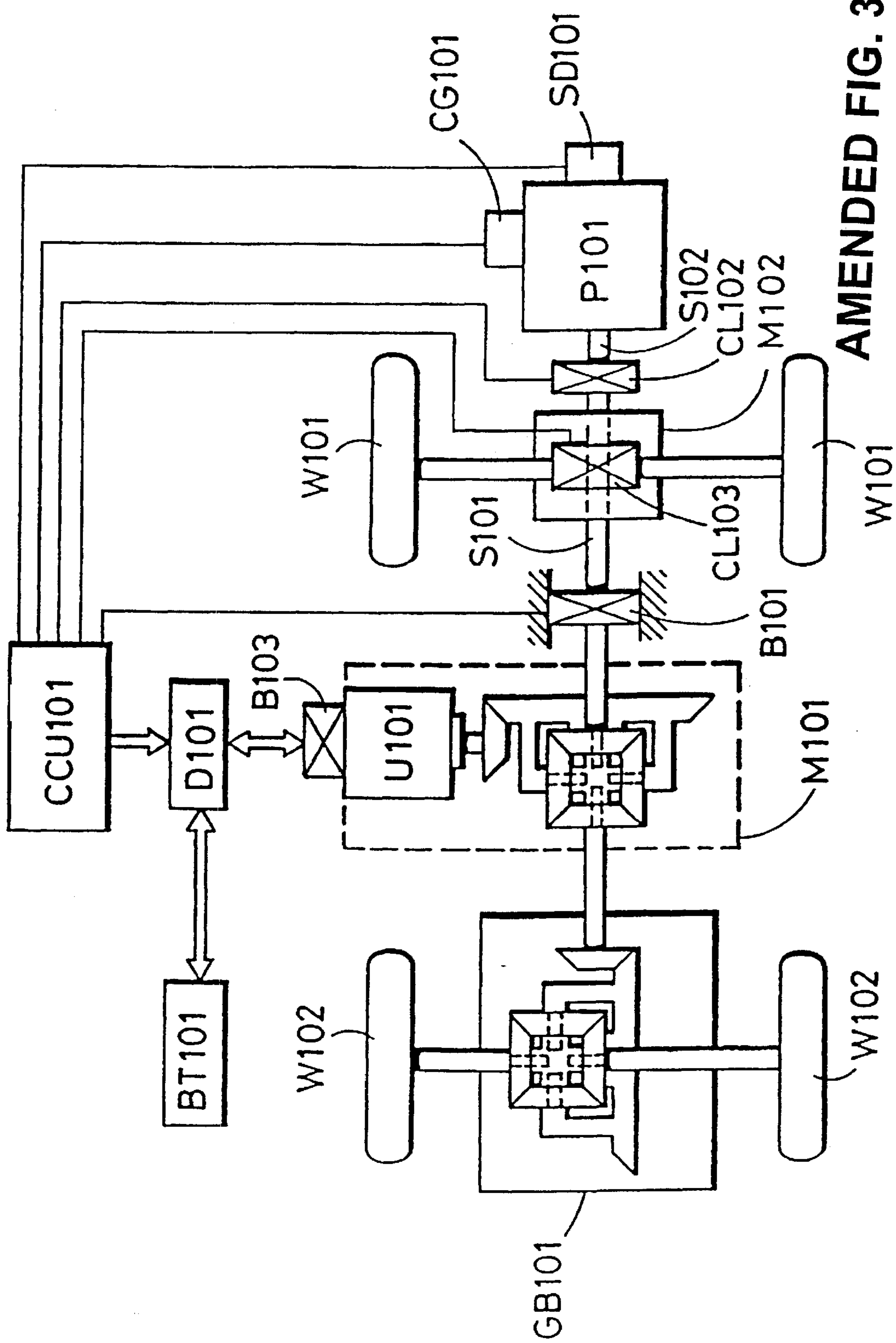

AMENDED FIG. 3

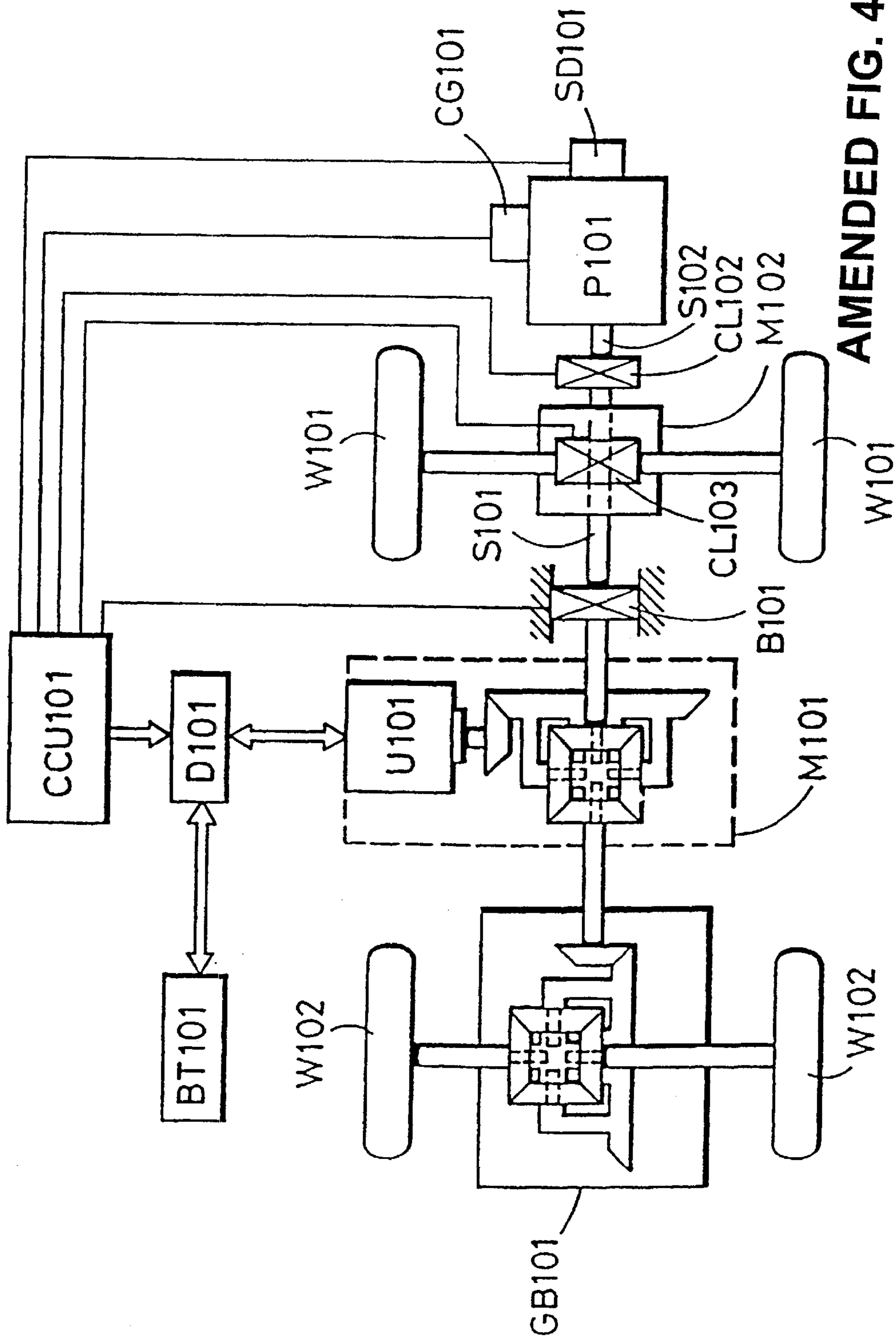

AMENDED FIG. 4

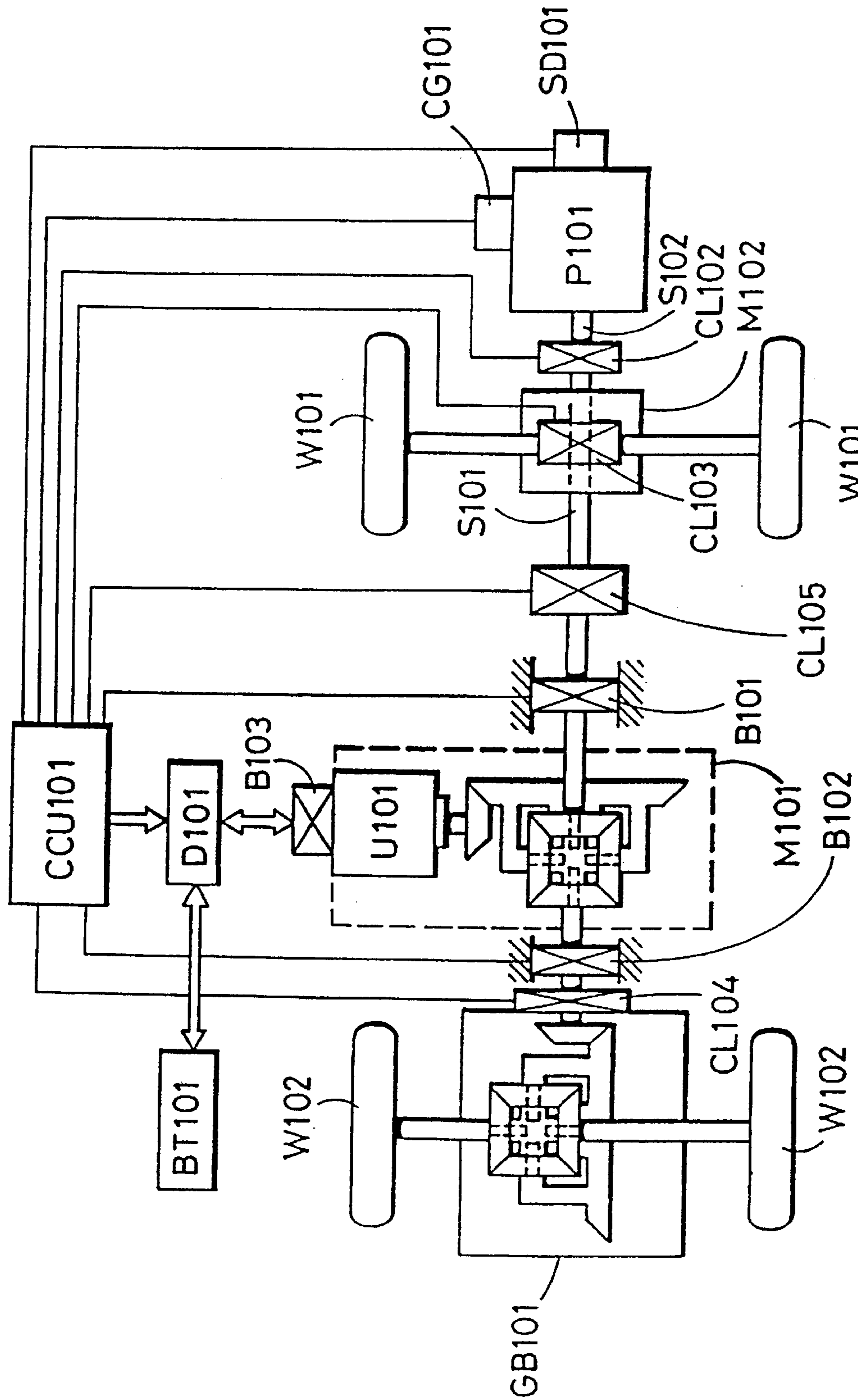

AMENDED FIG. 5

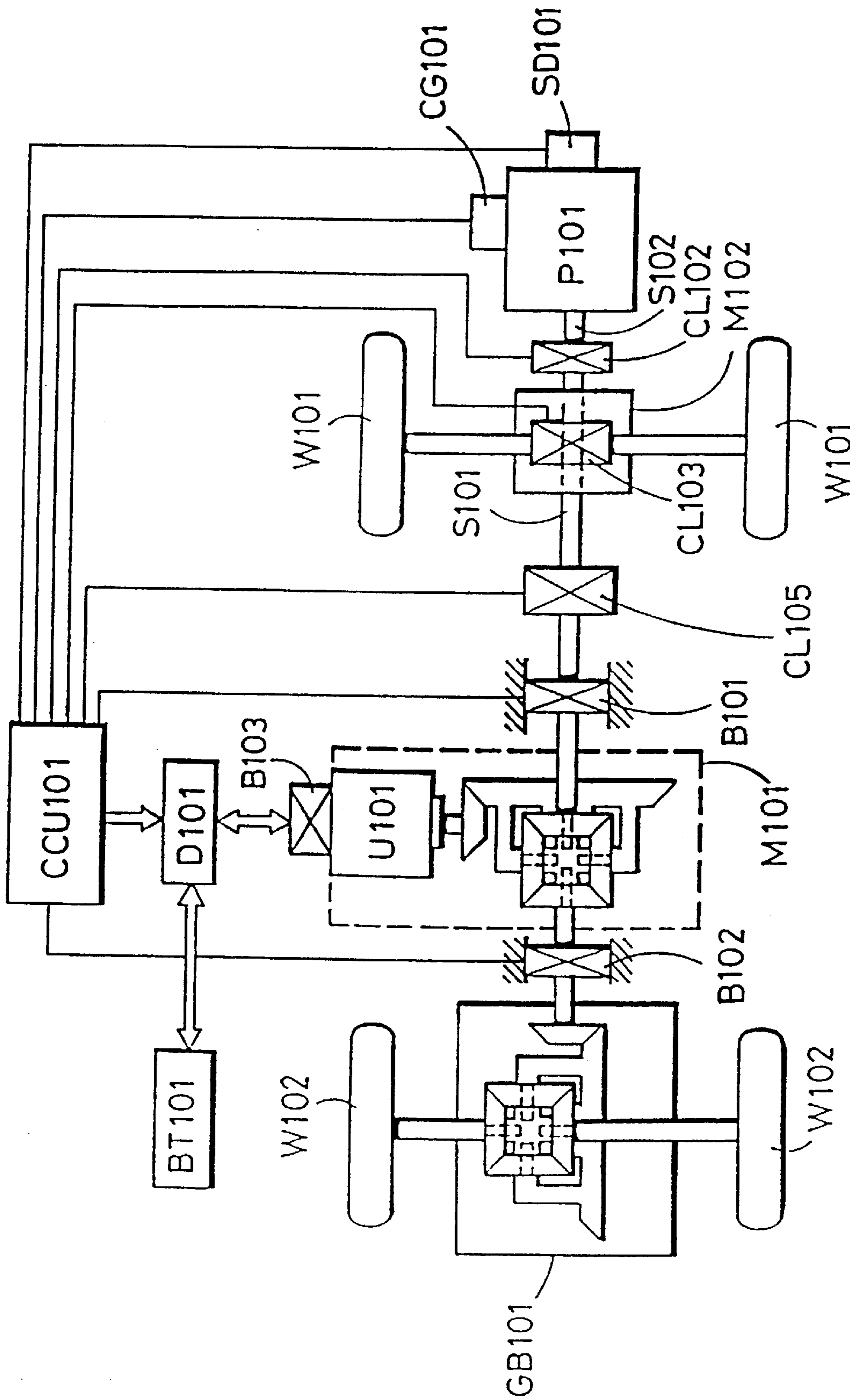

AMENDED FIG. 6

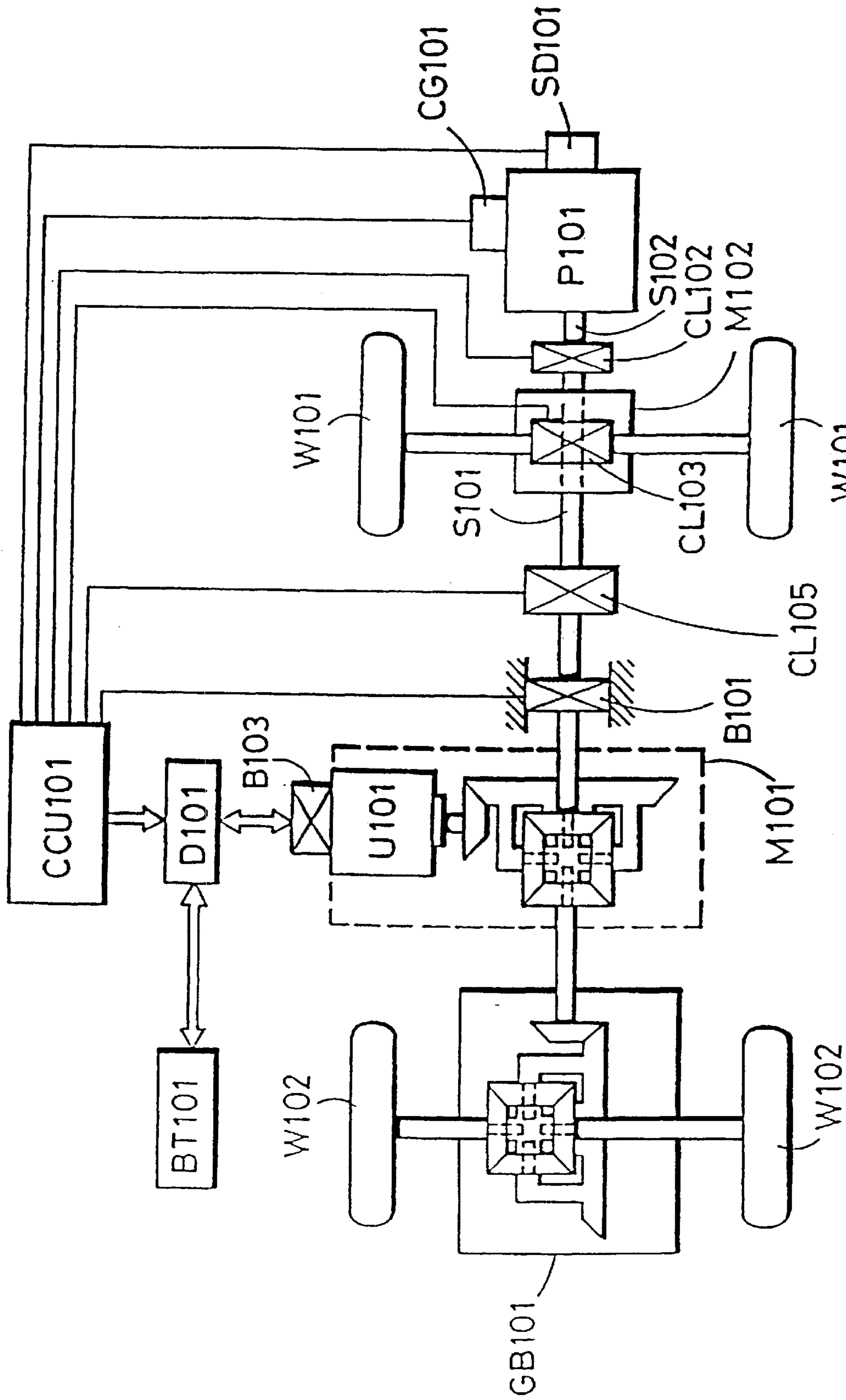

W101 AMENDED FIG. 7

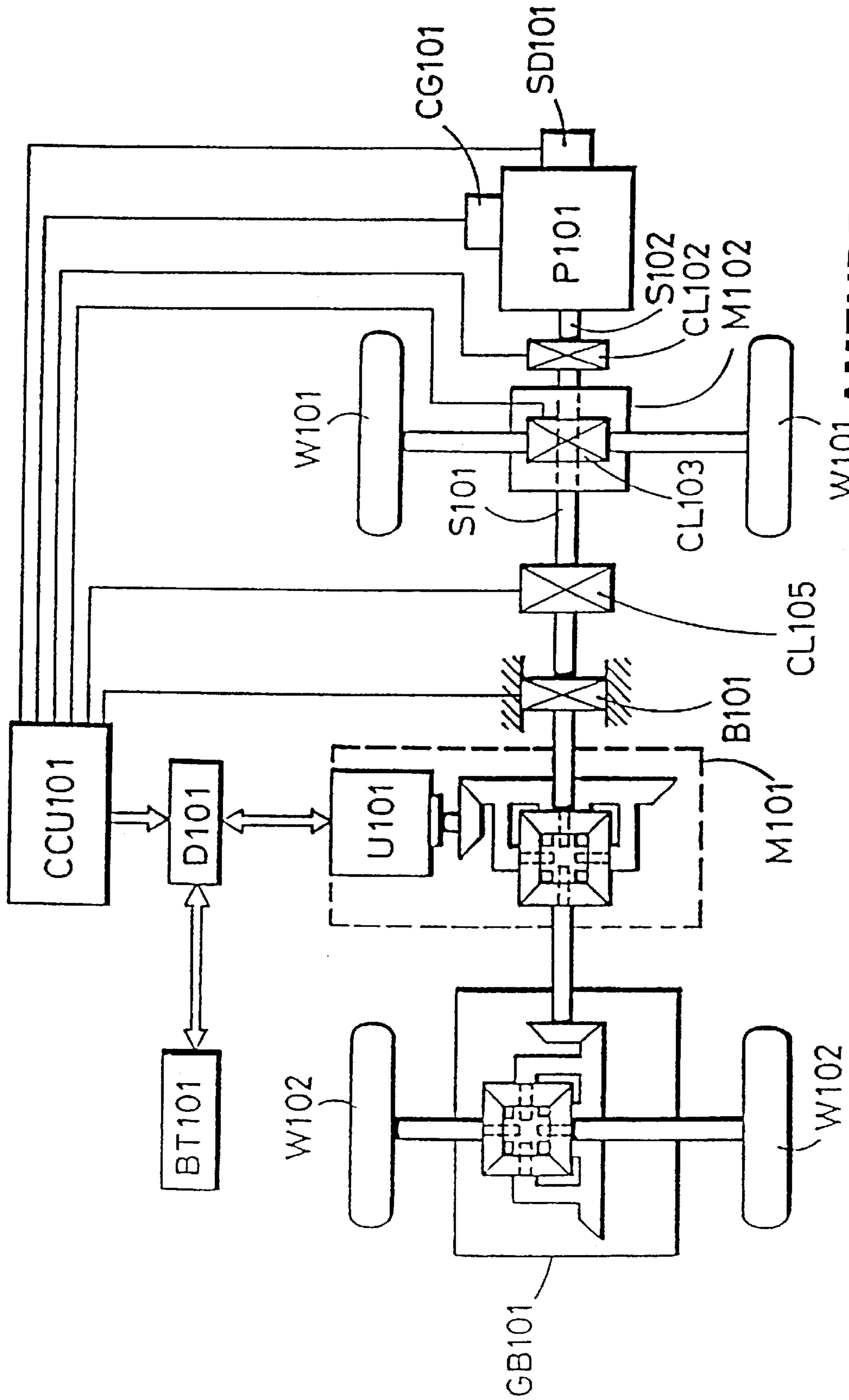

AMENDED FIG. 8

DISTRIBUTED DIFFERENTIAL MIXING COMBINED POWER SYSTEM

Matter enclosed in heavy brackets [] appears in the original patent but forms no part of this reissue specification; matter printed in italics indicates the additions made by reissue.

SUMMARY OF THE INVENTION

The distributed differential mixing combined power system is used in driving the traffic machinery such as vehicles, ships, flying machines or other mechanical structures (or other industrial or process equipment) in rotational driving applications, wherein it is chiefly comprised of that the rotational output shaft of the internal combustion engine (or other rotational power sources) is not only used to drive the front section load directly or through the transmission devices such as the transmission gears, belt or chain or the couplers, but is also coupled with the input shaft of the differential mixing drive unit to drive the rear section load. The said differential mixing drive device is comprised of an electrical machine combined with a three-end shaft differential wheels transmission system which is embodied in a three-end shaft differential gears structure, wherein the two differential output shaft and a input shaft are coupled with the electrical device through a transmission gear, while the two wheel shafts of the differential gears are respectively coupled with the transmission middle shaft driven by the drive side rotational power unit and are coupled with the input shaft of the rear differential gear box through a clutch to drive the two side differential acting rear section load; wherein the above said three-end shaft differential gears system can be substituted by a planetary gear train and the transmission gear can be substituted by a friction wheel; further, a brake is installed between the rotor and the stator of the electrical machine and the said brake is controlled by the operating device to generate motor driving functions when the input current is applied or to generate the variable speed coupling functions through the output current when it is employed as a generator, or to be used for starting the engine and the power regeneration brake which is particularly for case when the engine is the main transmission power source to charge the battery through the electrical machine of the differential mixing drive device, wherein the speed difference with the rear load section can be adjusted by controlling the charging current. The said engine can be at a constant speed or at a partially adjustable speed thereby to maintain at a working speed of higher operating efficiency and lower pollution and one part of the differential speed output power generated through the differential mixing drive device is used for driving the load while the rest part of the power is converted through the generator function of the electrical machine of the differential mixing drive device to charge the battery, thereby to promote the engine efficiency in the variable speed driving at the low driving speed range, to acquire the charging power to the battery while reducing the pollution, and to provide the variable speed coupling. Besides, it can also be used as a driving motor to generate rotational output to drive the load independently or to drive the load with the engine together.

BRIEF DESCRIPTION OF THE DRAWINGS

FIG. 1 is a embodying example of the invention
 FIG. 2 is the first application system of FIG. 1
 FIG. 3 is the second application system of FIG. 1
 FIG. 4 is the third application system of FIG. 1

FIG. 5 is the fourth application system of FIG. 1
 FIG. 6 is the fifth application system of FIG. 1
 FIG. 7 is the sixth application system of FIG. 1
 FIG. 8 is the seventh application system of FIG. 1

DETAILED DESCRIPTION OF THE INVENTION

In recent years, the energy and noise pollution issues are becoming more and more serious, and a better solution to alleviate the problems is to use the electrical power driven carriers. However, the R&D of the electrical power driven carriers up to now is limited by the capacity of the batteries to achieve a larger moving range, while to increase the battery volume or the quantities will correspondingly increase the self-weight of the carrier resulting in consuming more electrical energy and does not meet the economic requirements. Therefore, before there us a big breakthrough in solving the battery technical problems, the more practical driving method is to use the combined driving structure designs, wherein the developed ones include:

(A) Series Combined Power design: This design is the most typical structure for the electrical driven vehicle, wherein the generator is driven by the engine to generate electricity and charge the battery, then the battery provides electricity to the driven motor to drive the vehicle. As the energy is converted several times, the overall efficiency of this design is low, such as the GM HX3 of General Motors.

(B) Synchronized Power on common shaft design: It is by directly series combining the engine power output shaft and the rotating shaft of the driven motor, thereby to generate driving and speed controlling functions, such as the West Germany sedan VW CHICO

For the case of the engine or the motor described in (B), only one of them can be selected for output transmission and the combination of their power output is not available.

The disclosed distributed differential mixing combined power system of the invention is characterized that the output power from the output shaft of the engine (or other rotational power source) is not only used to drive the front section load, but is also combined with a differential mixing drive device to drive the rear section load, wherein the electrical machine of the said differential mixing drive device is constituted by an AC or DC, brushed or brushless electric machine combined with the three-end shaft differential wheels transmission system which is embodied in a three-end shaft differential gears structure, wherein the two differential output shaft and a input shaft are coupled with the electrical device through a transmission gear, while the two wheel shafts of the differential gears are respectively coupled with the transmission middle shaft driven by the drive side rotational power unit and are coupled with the input shaft of the rear differential gear box through a clutch to drive the two side differential acting rear section load; wherein the above said three-end shaft differential gears system can be substituted by a planetary gear train and the transmission gear can be substituted by a friction wheel; further, a brake is installed between the rotor and the stator of the electrical machine and the said brake is controlled by the operating device to generate motor functions when the input current is applied or to generate the generator output functions pulled by the external force. This design can add up the power and speed of the engine output to the rear load section and the output generated by the electrical machine itself while the adding process is not affected by the speed relationship between the two; and in general, it has a smaller system volume and saves the cost and space. The said

electrical machine can be controlled by the operating device to generate motor driving functions when the input current is applied to drive the front section load or the rear section load, or to drive them simultaneously, or to start the engine, or to provide the generator output due to the rotation speed difference between the engine rotational power input and the driven load and to provide the differential adjusting function for the controllable speed change through the coupling torque generated by the output current, or to be used as the power regeneration brake which is particularly for case when the engine is the main-transmission power source to charge the battery through the speed difference between the two differential shafts of the three-end shaft differential gears system in the differential mixing drive device structure, wherein the speed difference with the rear load section can be adjusted by controlling the charging current. The said engine can be at a constant speed or at a partially adjustable speed thereby to maintain at a working speed of higher operating efficiency and lower pollution and one part of the differential speed output power generated through the differential mixing drive device is used for driving the load while the rest part of the power is converted through the generator function of the electromagnetic coupling device to charge the battery, thereby to promote the engine efficiency in the variable speed driving at the low driving speed range, to acquire the charging power to the battery while reducing the pollution, and to provide the variable speed coupling. Besides, it can also be used as a driving motor to generate rotational output to drive the load independently or to drive the load with the engine together.

The invention is illustrated according to the embodying examples shown in the enclosed drawings as follows:

FIG. 1 is the embodying example of the distributed differential mixing combined power system, which is characterized in:

A drive side rotational power source **P101**, wherein its output is first supplied to control the front section load and is then transmitted to the input end of the differential mixing drive device **M101** to drive the rear section load.

A differential mixing drive device **M101**, wherein the transmission methods of its output end and its rear end include the direct transmission to another load (or through a transmission component to another load), or transmission to the differential acting load through the rear differential wheels train (such as the vehicle side rear wheels), and it is mainly comprised of the following:

A drive side rotational power unit **P101**: It is an internal engine or other power source, wherein the rotational output shaft **S102** is coupled to the middle transmission device and the control interface **M102** through the clutch **CL102**, and the said internal engine is further installed with a speed sensor **SD101** to transmit the engine rotation signal to the central controller **CCU101**, wherein the controllable fuel valve **CG101** is controlled by the said central controller **CCU101** to change the engine speed or to keep the engine maintained at a constant speed;

A middle transmission device and a control interface **M102** which is comprised of the automatic or manual speed change control system in the conventional front wheel driven system to drive the front section load only or to drive the whole loads; the clutch **CL103** is installed between the middle input shaft **S101** and the front section load to provide the transmission coupling or to cut off the transmission relationship between the middle transmission device and the front wheels, and the said clutch **CL103** can also be substituted by the neutral shift or co-installed with the neutral shift

when the shift interface is at the neutral shift status. The said middle shaft **S101** is coupled at the output end of the clutch **CL102** is either directly rear extended or through a transmission device to render the rotation speeds between the middle shaft **S101** and the output presented in a constant speed ratio or a non-constant speed ratio (it is similar to the rear extended rear wheel transmission shaft in the four wheel drive). A brake **B101** controlled by the central controller **CCU101** is further installed between the middle shaft **S101** and the fixed casing;

A direct driven front section load **W101**: It is comprised of one or more than one drive wheels with driven resistance of the load;

A differential mixing drive device **M101**: It is comprised of an electric machine **U101** combined with the three-end shaft differential wheels transmission system which is embodied in a three-end shaft differential gears structure, wherein the two differential output shaft and a input shaft are coupled with the electrical device **U101** through a transmission gear, while the two wheel shafts of the differential gears are respectively coupled with the transmission middle shaft **S101** driven by the drive side rotational power unit and are coupled with the input shaft of the rear differential gear box **GB101** through a clutch **CL104** to drive the two side differential acting rear section load **W102**; wherein the above said three-end shaft differential gears system can be substituted by a planetary gear train and the transmission gear can be substituted by a friction wheel.

An electrical machine **U101**: Wherein between its rotor and its stator, a brake **B103** is installed to be controlled by the central controller **CCU101** to make a direct mechanical synchronous interlock on the rotor and stator of the electrical machine **U101**, wherein the above said electrical machine **U101** is comprised of an AC or DC, brushed or brushless electrical machine structure, and is particularly suitable to be constituted by a series excited or auxiliary compound excited electrical machine with the electrical characteristic of rotational speed increased corresponding to the decreasing load, or an AC or DC brush or brushless machine able to perform current control (including constant current control) through the operating control of the drive circuit **D101** to help provide the additional torque on the driven load;

A drive circuit device **D101** which is installed between the electrical machine **U101** and the battery **BT101**, wherein it receives the operating commands from the central controller **CCU101** to control the electrical machine **U101** functioned as a generator to charge the battery or supply power to the other load or to provide a current controllable generation output;

A central controller **CCU101** which follows the commands from the operator and the operating status of the drive side rotational power unit **P101** to generate the corresponding control commands to the drive circuit device **D101**;

A brake **B102** can be installed as needed between the casing and the jointing side of the clutch **CL104** which is located between the differential acting output shaft of the differential mixing drive device **M101** and the coupled rear differential gear box, thereby to drive the front section load or to start the engine, or to provide power generation at standstill, wherein the electrical machine **U101** is driven by the engine to function as a generator to charge the battery or supply power to the other loads. For the case of AC power generation output functions, the said **U101** is selected to employ the electrical machine with AC power generating functions comprised of a permanent magnet or winding

excited, varied frequency driven field type electrical device, or a brushed alternator type electrical device, wherein its armature winding is commonly installed the conducting rings for AC output and the commutators for DC input/output, whereby the AC output can be a varied frequency output or a constant frequency output through the engine constant speed control;

The afore said direct driven load and the distributed differential load are comprised of one or more than one rotational power sources, or one or more than one direct driven load, or one or more than one differential mixing drive device **M101** and its driven load groups in sequential series combinations of an enlarged type compound series combined structure.

Functions of the embodying example shown in FIG. 1 as is delineated in Table 1 as follows:

F1-A F1-B F1-C F1-D: They are the various system operations when the engine drives the load at low speed output;

F2 and F3: They are the system operations when the electrical machine **U101** is powered by the battery to drive the load as a motor;

F4-A and F4-B: They are the system operations when the electrical machine **U101** is powered by the battery to be operated as a motor and is driving the load with the engine together, thereby to have large power output through the output power addition;

F5, F6 and F7: They are the system operations when the electrical machine **U101** is operated as a generator driven by the feedback mechanical energy of the load to charge the battery or to function as a brake by utilizing the friction damping of the engine itself;

F8: It is the system operation when the electrical machine **U101** is driven by the engine to operated as a generator to charge the battery: This function can be further included with a charging timing control to stop automatically at a preset time. For the case of AC power generation output functions, the said **U101** is selected to employ the electrical machine with AC power generating functions comprised of a permanent magnet or winding excited, varied frequency driven field type electrical device, or a brushed alternator type electrical device, wherein its armature winding is commonly installed the conducting rings for AC output and the commutators for DC input/output, whereby the AC output can be a varied frequency output or a constant frequency output through the engine constant speed control;

F9: The electrical machine **U101** is operated as a motor and is powered by the battery to start the engine;

F10: The neutral sliding is that all the system clutches and brakes are at "OFF" state to provide low loss sliding operation;

The above system operating functions are described as follows:

F1-A: The engine fuel valve is controlled to drive the engine from low speed to high speed which is comprised of the following:

The internal engine is the drive side rotational power source which is controlled by the engine fuel valve to drive the rear section load, wherein the clutches **CL102** and **CL104** are at ON state while the **CL103** is at OFF state and the brakes **B101** and **B102** are at OFF state while the **B103** is at the ON state.

The internal engine is the drive side rotational power source which is controlled by the engine fuel valve to drive the front and rear section loads, wherein the clutches **CL102**,

CL103 and **CL104** are all at ON state and the brakes **B101** and **B102** are at OFF state, while the brake **B103** is at the ON state;

The internal engine is the drive side rotational power source which is controlled by the engine fuel valve to drive the front section load, wherein the clutches **CL102** and **CL103** are at ON state while the **CL104** are at OFF state and the brakes **B101**, **B102**, **B103** are all at the OFF state;

F1-B: The engine fuel valve and the electrical machine **U101** is controlled simultaneously to drive the engine from low speed to high speed and to charge the battery simultaneously, which is comprised of the following:

The internal engine is the drive side rotational power source which is controlled by the engine fuel valve on the engine speed change and to operate the electrical machine **U101** is a generator to charge the battery and to drive the rear section load, wherein the clutch **CL103** is at OFF state while the **CL102** and **CL104** are at ON state and the brakes **B101**, **B102** and **B103** are all at OFF state;

The internal engine is the drive side rotational power source which is controlled by the engine fuel valve on the engine speed change and to operate the electrical machine **U101** as a generator to charge the battery and to drive the front and rear section loads together with the engine, wherein the clutches **CL102**, **CL103** and **CL104** are at ON state and the brakes **B101**, **B102** and **B103** are all at OFF state;

The internal engine is the drive side rotational power source which is controlled by the engine fuel valve on the engine speed change and to drive the front section load as well as to operate the electrical machine **U101** as a generator to charge the battery at the same time, wherein the clutch **CL104** is at OFF state while the **CL102** and **CL103** are at ON state; Further, the brakes **B101** and **B103** are OFF while the **B102** is at ON state;

F1-C: The engine is speed controlled or operated at a constant speed, wherein the battery charging current from the electrical machine **U101** is controlled to change the output power to the load and it is comprised of the following:

The internal engine is the drive side rotational power source, wherein the engine is controlled by the engine fuel valve and the speed feedback signal to operate at constant speed as well as to operate the electrical machine **U101** to charge the battery, thereby to adjust the coupling torque to drive the rear section load, wherein the clutches **CL103** is at OFF state while the **CL102** and **CL104** are at ON state and the brakes **B101**, **B102** and **B103** are at OFF state;

The internal engine is the drive side rotational power source, wherein the engine speed is controlled by the engine fuel valve and the speed feedback signal to drive the front section load as well as to operate the electrical machine **U101** to charge the battery, thereby to adjust the coupling torque to drive the rear section load, wherein the clutches the **CL102**, **CL103** and **CL104** are at ON state and the brakes **B101**, **B102** and **B103** are at OFF state;

F1-D: The electrical machine **U101** generates short cut current to control the output-shaft torque, thereby to change the engine speed and is comprised of the following:

The internal engine is the drive side rotational power source, wherein the engine fuel valve and the speed feedback signal are utilized to control the engine speed and simultaneously to operate the electrical machine **U101** as a generator and control on the generated short cut circuit current to change its coupled torque, thereby to change the

transmission power to the front and rear section loads, wherein the clutch CL103 is at OFF state, while the CL102 and CL104 are at ON state and the brake B101, B102 and B103 are at OFF state;

The internal engine is the drive side rotational power source, wherein the engine fuel valve and the speed feedback signal are utilized to control the engine speed and simultaneously to operate the electrical machine U101 as a generator and control on the generated short cut circuit current to charge its coupled torque, thereby to change the transmission power to the front and rear section loads, wherein the CL102, CL103 and CL104 are at ON state and the brakes B101 and B102 are at OFF state;

F2: The electrical machine U101 is powered by the battery to change the speed or the rotation direction of the rear section load, which is comprised of the following:

The electrical machine U101 is powered by the battery to drive the rear section load: At this time, the said electrical machine U101 is operated as a motor and the brake B101 is at ON state while the brake B102 and B103 are at OFF state. The clutch CL102 and the clutch CL103 for controlling the front section load are at OFF state, and the CL104 is at ON state;

F3: The electrical machine U101 is powered by the battery to change the speed or the rotation direction of the front section load, which is comprised of the following:

The electrical machine U101 is powered by the battery to drive the front section load: At this time, the electrical machine U101 is operated as a motor while the brake B102 is at the ON state and the B101 and B103 are at OFF state, the clutches CL102 and CL104 are at OFF state, and the CL103 is at ON state;

F4-A: The engine is operated at a preset speed while the electrical machine U101 is operated as a motor to provide added power output to drive the rear section load, which is comprised of the following:

The internal engine is the drive side rotational power source, wherein the engine is operated at a varied or constant speed and the electrical machine U101 is powered by the battery at the same time, thereby to provide the added power output to drive the rear section load simultaneously. At this time, the clutch CL103 is at OFF state while the CL102 and CL104 are at ON state and the brakes B101, B102 and B103 are all at OFF state;

F4-B: The engine is operated at a preset speed while the electrical machine U101 is operated as a motor to provide added power output to drive the front and rear section loads, which is comprised of the following:

The internal engine is the drive side rotational power source, wherein the engine is operated at a variant or constant speed and the electrical machine U101 is powered by the battery at the same time, thereby to provide the added power output to drive the front and rear section loads simultaneously. At this time, the CL102, CL103 and CL104 are at ON state and the brake B101, B102 and B103 are at OFF state;

F5: The electrical machine U101 is operated as a generator to charge the battery using the recovered rear section kinetic energy, which is comprised of the following:

The engine speed is reduced or the fuel valve is closed and the electrical machine U101 is operated as a generator to convert the rotational mechanical energy of the rear section load into the electric power to charge the battery, or to consume the electric power by the other loads, thereby to obtain the friction damping and together with the engine

piston friction damping to constitute the braking friction damping, wherein the brakes B101, B102 and B103 are at OFF state, the clutch CL103 is at OFF state, the CL102 and CL104 are at ON state, and the engine can be stopped or slowly operated;

The electrical machine U101 is operated as a generator to convert the rotational mechanical energy of the rear section load into the electric power to charge the battery, or to consume the electric power by the other loads, thereby to obtain the friction damping, wherein the brake B101 is at ON state while the B102 and B103 are at OFF state, and the clutches CL102 and CL103 are at OFF state, and the engine can be stopped or operated at a slower speed than the sliding speed, and when the CL104 is at ON state, the engine can be at operating or stop;

F6: The electrical machine U101 is operated as a generator to charge the battery using the recovered front section kinetic energy, which is comprised of the following:

The engine speed is reduced or the fuel valve is closed and the electrical machine U101 is operated as a generator to convert the rotational mechanical energy of the front section load into the electric power to charge the battery, or to consume the electric power by the other loads, thereby to obtain the friction damping and together with the engine piston friction damping to constitute the braking friction damping, wherein the brakes B101 and B103 are at OFF state, while the B102 is at ON state, and the clutch CL104 is at OFF state, while the CL102 and CL103 are at ON state, and the engine can be stopped or slowly operated;

The electrical machine U101 is operated as a generator to convert the rotational mechanical energy of the front section load into the electric power to charge the battery, or to consume the electric power by the other loads, thereby to obtain the friction damping, wherein the brake B102 is at ON state, and the B101 and B103 are at OFF state, the clutches CL102 and CL104 are at OFF state, while the CL103 is at ON state and the engine can be stopped or operated at a slower speed than the sliding speed, and when the CL102 is at OFF state, the engine can be at operating state or stopped;

F7: All the loads are braked by the engine friction damping, which is comprised of the following:

The engine speed is reduced or the fuel valve is closed and the generator is operated to convert the rotational mechanical energy of the front and rear section loads into the friction damping and together with the engine piston friction damping to constitute the braking friction damping, wherein the brake B101, B102 and B103 are at OFF state, the clutches the CL102, CL103 and CL104 are at ON state, and the engine can be stopped or slowly operated;

F8: The system is self charged, which is comprised of the following:

The electrical machine U101 is driven by the drive side rotational power source to be operated as a generator to charge the battery or supply power to the other loads. At this time when the engine is started, the brakes B101 and B103 are at OFF state, while the B102 is at ON state, and the clutches CL103 and CL104 are at OFF state, while the CL102 is at ON state; and the timer can be further utilized to preset the engine charging time or control the charging capacity for automatic stop. For the case of AC power output function, the said U101 is selected to employ the electrical machine with AC power generating functions comprised of

a permanent magnet or winding excited, varied frequency driven field type electrical device, or a brushed alternator type electrical device, wherein its armature winding is commonly installed the conducting rings for AC output and the commutators for DC input/output, wherein the AC output can be provided at a varied frequency or a constant frequency through the engine constant speed control;

F9: The electrical machine **U101** is operated as a motor to start the engine, which is comprised of the following:

The electrical machine **U101** is used to start the drive side engine: At this time, the brake **B102** is at ON state, while the **B101** and **B103** is at OFF state, and the front section operating interface **M102** and the front section coupled clutches **CL103** and **CL104** are at OFF state, while the Clutch **CL102** is at ON state;

F10: Neutral slide: It is the slide function of the system when no power output and brake are activated, which is comprised of the following:

The engine can be at operating state or stopped, the brake **B101**, **B102** and **B103** are at OFF state, the clutches **CL102**, **CL103** and **CL104** are all at OFF state.

The embodying example of the distributed differential mixing combined power system in FIG. 1 are comprised of the following variations in the practical applications:

FIG. 2 is the first application system of FIG. 1: It discloses the application example of eliminating the clutch **CL104**, and the system functions are delineated in Table 2.

FIG. 3 is the second application system of FIG. 1: It discloses the application example of eliminating the clutch **CL104** and the brake **B102**, and the system functions are delineated in Table 3.

FIG. 4 is the third application system of FIG. 1: It discloses the application example of eliminating the **B102**, **B103** and **CL104**, and the system functions are delineated in Table 4.

FIG. 5 is the fourth application system of FIG. 1: It discloses the application example of further installing the clutch **CL105** between rear section output middle shaft and middle transmission device while the clutch **CL103** for controlling the front section load is reserved (or the said clutch is replaced by the speed change shift of the middle transmission device), and the system functions are delineated in Table 5, wherein besides of the functions delineated in Table 1, the additional functions are described as follows:

F11: The engine is used to drive the front section load, and the electrical machine **U101** is powered by the battery to drive the rear section load, and both are independently operated to drive the respective loads, wherein the brake **B101** is at ON state, while the **B102** and **B103** are at OFF state, and the clutch **CL105** is at OFF state, while the **CL102**, **CL103** and **CL104** are at ON state;

F12: The engine is used to drive the front section load and the electrical machine **U101** is pulled to be operated as a generator to charge the battery, wherein the brake **B101** is at ON state, while the **B102** and **B103** are at OFF state, and the clutch **CL105** is at OFF state, while the **CL102**, **CL103** and **CL104** are at ON state.

FIG. 6 is the fifth application system of FIG. 1: It discloses the application example of further installing the clutch **CL105** between the rear section output middle shaft and the middle transmission device and eliminating the clutch **CL104**, and the system functions are delineated in Table 6.

FIG. 7 is the sixth application system of FIG. 1: It discloses the application example of further installing the clutch **CL105** between the rear section output middle shaft and the middle transmission device and eliminating the clutch **CL104** and brake **B102**, and the system functions are delineated in Table 7.

FIG. 8 is the seventh application system of FIG. 1: It discloses the application example of further installing the clutch **CL105** and eliminating the clutch **CL104** and brakes **B102** and **B103**, and the system functions are delineated in Table 8.

The above described application examples are for reference only, wherein the practical applications can be achieved by rendering the front and the rear section loads constituted in a distributed differential mixing structure of the combined driving characteristics on the loads according to the performance requirements without changing the design of this invention to select the corresponding operating and control components.

For the case when the system of the embodying examples in FIG. 1-8 are applied on the carriers, the angle displacement relationships between the front and rear section loads and the drive power source resulted from the transmission ratio and the wheel outside diameter differences include: The angle displacement speed of the two loads and the drive side rotational power source are operated according to the wheel system ratio relationships, or the angle displacement relationship between the two loads and their operations with the drive side rotational power source are not according to the wheel system ratio (such as slipping on the road surface), particularly, the relationships between the angle displacement of the rear section load and the drive side power source or between the front and rear section loads can be specially set not to operate according to the wheel system ratio relationship, but to operate through the differential acting adjustment by the electrical machine **U101**;

The differential acting adjustment of the electrical machine **U101** includes the active adjustment through input power to function as a motor or the passive adjustment through functioning as a generator to output power;

In the carrier driving applications of the afore said front section load and the rear section load, the front section load can be the front wheel or the rear wheel, the rear section-load can be the matched front wheel or rear wheel structure with the afore said definition;

The distributed differential mixing combined power system has numerous operating functions in the section differential driving characteristic structure, therefore in the practical applications, it can be embodied to be comprised of all the functions or part of the functions.

As summarized from the above descriptions, the distributed differential mixing combined power system can be applied at vehicles, boats or utilized as other fixed combined driving power. The afore said embodying examples disclose the various application modes of the distributed differential mixing combined power system of the invention and in practical applications, the peripheral components for the output functions can be selected according to needs, thereby to flexibly select the required system.

TABLE 1

FUNCTIONS	COMPONENTS		
	B101	P101	CL102
F1-A The engine fuel valve is controlled to drive the engine from low speed to high speed	OFF	0-MAX	ON
F1-B The engine fuel valve and the U101 is controlled simultaneously to drive the engine from low speed to high speed and to charge the battery simultaneously	OFF	0-MAX	ON
F1-C The engine is speed controlled or operated at a constant speed, wherein the battery charging current from the U101 is controlled to change the output power to the load;	OFF	*0-MAX OR CONSTANT SPEED **0-MAX	ON
F1-D The engine is speed controlled or operated at a constant speed, wherein the U101 generates short cut current to control the output shaft torque, thereby to change the engine speed	OFF	*0-MAX OR CONSTANT SPEED **0-MAX	ON
F2 The U101 is powered by the battery to change the speed or the rotation direction of the rear section load	ON	STOP	OFF
F4-A The engine is operated at a preset speed while the U101 is operated as a motor to provide added power output to drive the rear section load	OFF	0-MAX OR CONSTANT SPEED	ON
F4-B The engine is operated at a preset speed while the U101 is operated as a motor to provide added power output to drive the front and rear section loads	OFF	0-MAX CONSTANT SPEED	ON
F5 The U101 is operated as a generator to charge the battery using the recovered rear section kinetic energy	*OFF **ON	*SLOW OR STOP **STOP-MAX	*ON **OFF
F6 The U101 is operated as a generator to charge the battery using the recovered front section kinetic energy	OFF	*SLOW OR STOP **STOP-MAX	*ON **OFF
F7 All the loads are braked by the engine friction damping	OFF	SLOW OR STOP	ON
F8 The system is self charged (It can be stopped at a preset time or controlled by the capacity) through that the U101 is driven by the engine to be operated as a generator to charge the battery or to provide varied or constant frequency AC generation output	OFF	0-MAX OR CONSTANT SPEED	ON
F9 The U101 is operated as a motor to start the engine	OFF	STOP TO START	ON
F10 Neutral Slide	OFF	STOP OR 0-MAX	OFF

FUNCTIONS	COMPONENTS			
	CL103	G/M (U101)	BT101	REMARK
F1-A The engine fuel valve is controlled to drive the engine from low speed to high speed	*OFF **ON ***ON	*READY **READY ***READY	*READY **READY ***READY	*Drive the rear section load
F1-B The engine fuel valve and the U101 is controlled simultaneously to drive the engine from low speed to high speed and to charge the battery simultaneously	*OFF **ON ***ON	GEN-	CHARGE	**Drive the front and rear section loads simultaneously ***Drive the front section load
F1-C The engine is speed controlled or operated at a constant speed, wherein the battery charging current from the U101 is controlled to change the output power to the load;	*OFF **ON	GEN-	DIS-CHARGE	
F1-D The engine is speed controlled or operated at a constant speed, wherein the U101 generates short cut current to control the output shaft torque, thereby to change the engine speed	*OFF **ON	GEN-	READY	
F2 The U101 is powered by the battery to change the speed or the rotation direction of the rear section load	OFF	MOTOR	DIS-CHARGE	
F4-A The engine is operated at a preset speed while the U101 is operated as a motor to provide added power output to drive the rear section load	OFF	MOTOR	DIS-CHARGE	
F4-B The engine is operated at a preset speed while the U101 is operated as a motor to provide added power output to drive the front and rear section loads	ON	MOTOR	DIS-CHARGE	
F5 The U101 is operated as a generator to charge the battery using the recovered rear section kinetic energy	OFF	GEN-	CHARGE	*The engine piston friction damping is activated simultaneously **Recovery of the kinetic energy
F6 The U101 is operated as a generator to charge the battery using the recovered front section kinetic energy	ON	GEN-	CHARGE	

TABLE 1-continued

F7	All the loads are braked by the engine friction damping	ON	READY	READY	
F8	The system is self charged (It can be stopped at a preset time or controlled by the capacity) through that the U101 is driven by the engine to be operated as a generator to charge the battery or to provide varied or constant frequency AC generation output	OFF	GEN-	CHARGE	The operation is limited to when the engine is stopped and the rear load brake is locked.
F9	The U101 is operated as a motor to start the engine	OFF	MOTOR	DIS-CHARGE	
F10	Neutral Slide	OFF	READY	READY	

Notes:

- 1) CHARGE current of F1-B is load following distributed
- 2) The U101 is an electrical machine
- 3) BT101 is the battery
- 4) GEN- is a generator
- 5) For the case of engine, the P101 is the drive side rotational power source which is employed to drive the front section load and is series combined with the U101 to drive the rear section load
- 6) For the case of AC power output function in F8, the said U101 is selected to employ the electrical machine with AC power generating functions comprised of a permanent magnet or winding excited, varied frequency driven field type electrical device, or a brushed alternator type electrical device, wherein its armature winding is commonly installed the conducting rings for AC output and the commutators for DC input/output.

TABLE 2

FUNCTIONS	COMPONENTS				
	B101	B102	P101	B103	CL102
F1-A The engine fuel valve is controlled to drive the engine from low speed to high speed	OFF	*OFF **OFF ***OFF	0-MAX	*ON **ON ***OFF	ON
F1-B The engine fuel valve and the U101 is controlled simultaneously to drive the engine from low speed to high speed and to charge the battery simultaneously	OFF	*OFF **OFF ***ON	0-MAX	*OFF	ON
F1-C The engine is speed controlled or operated at a constant speed, wherein the battery charging current from the U101 is controlled to change the output power to the load;	OFF	OFF	*0-MAX OR CONSTANT SPEED **0-MAX	OFF	ON
F1-D The engine is speed controlled or operated at a constant speed, wherein the U101 generates short cut current to control the output shaft torque, thereby to change the engine speed	OFF	OFF	*0-MAX OR CONSTANT SPEED **0-MAX	OFF	ON
F2 The U101 is powered by the battery to change the speed or the rotation direction of the rear section load	ON	OFF	STOP	OFF	OFF
F4-A The engine is operated at a preset speed while the U101 is operated as a motor to provide added power output to drive the rear section load	OFF	OFF	0-MAX OR CONSTANT SPEED	OFF	ON
F4-B The engine is operated at a preset speed while the U101 is operated as a motor to provide added power output to drive the front and rear section loads	OFF	OFF	0-MAX	OFF	ON
F5 The U101 is operated as a generator to charge the battery using the recovered rear section kinetic energy	*OFF **ON	OFF	*SLOW OR STOP **STOP-MAX	OFF	*ON **OFF
F7 All the loads are braked by the engine friction damping	OFF	OFF	SLOW OR STOP	OFF	ON
F8 The system is self charged (It can be stopped at a preset time or controlled by the capacity) through that the U101 is driven by the engine to be operated as a generator to charge the battery or to provide varied or constant frequency AC generation output	OFF	ON	0-MAX OR CONSTANT SPEED	OFF	ON
F9 The U101 is operated as a motor to start the engine	OFF	ON	STOP TO START	OFF	ON
F10 Neutral Slide	OFF	OFF	STOP OR 0-MAX	OFF	OFF

FUNCTIONS	COMPONENTS			
	CL103	G/M (U101)	BT101	REMARK
F1-A The engine fuel valve is controlled to drive the engine from low speed to high speed	*OFF **ON ***ON	*READY **READY ***READY	*READY **READY ***READY	*Drive the rear section load
F1-B The engine fuel valve and the U101 is controlled simultaneously to drive the engine from low speed to high speed and to charge the battery simultaneously	*OFF **ON ***ON	GEN-	CHARGE	**Drive the front and rear

TABLE 2-continued

F1-C	The engine is speed controlled or operated at a constant speed, wherein the battery charging current from the U101 is controlled to change the output power to the load;	*OFF **ON	GEN-	DIS- CHARGE	section loads simultaneously ***Drive
F1-D	The engine is speed controlled or operated at a constant speed, wherein the U101 generates short cut current to control the output shaft torque, thereby to change the engine speed	*OFF **ON	GEN-	READY	the front section load
F2	The U101 is powered by the battery to change the speed or the rotation direction of the rear section load	OFF	MOTOR	DIS- CHARGE	
F4-A	The engine is operated at a preset speed while the U101 is operated as a motor to provide added power output to drive the rear section load	OFF	MOTOR	DIS- CHARGE	
F4-B	The engine is operated at a preset speed while the U101 is operated as a motor to provide added power output to drive the front and rear section loads	ON	MOTOR	DIS- CHARGE	
F5	The U101 is operated as a generator to charge the battery using the recovered rear section kinetic energy	OFF	GEN-	CHARGE	*The engine piston friction damping is activated simultaneously **Recovery of the kinetic energy
F7	All the loads are braked by the engine friction damping	ON	READY	READY	
F8	The system is self charged (It can be stopped at a preset time or controlled by the capacity) through that the U101 is dried by the engine to be operated as a generator to charge the battery or to provide varied or constant frequency AC generation output	OFF	GEN-	CHARGE	The operation is limited to when the engine is stopped.
F9	The U101 is operated as a motor to start the engine	OFF	MOTOR	DIS- CHARGE	
F10	Neutral Slide	OFF	READY	READY	

Notes:

- 1) CHARGE current of F1-B is load following distributed
- 2) The U101 is an electrical machine
- 3) BT101 is the battery
- 4) GEN- is a generator
- 5) For the case of engine, the P101 is the drive side rotational power source which is employed to drive the front section load and is series combined with the U101 to drive the rear section load
- 6) For the case of AC power output function in F8, the said U101 is selected to employ the electrical machine with AC power generating functions comprised of a permanent magnet or winding excited, varied frequency driven field type electrical device, or a brushed alternator type electrical device, wherein its armature winding is commonly installed the conducting rings for AC output and the commutators for DC input/output.

TABLE 3

FUNCTIONS	COMPONENTS			
	B101	P101	B103	CL102
F1-A The engine fuel valve is controlled to drive the engine from low speed to high speed	OFF	0-MAX	*ON **ON ***OFF	ON
F1-B The engine fuel valve and the U101 is controlled simultaneously to drive the engine from low speed to high speed and to charge the battery simultaneously	OFF	0-MAX	*OFF	ON
F1-C The engine is speed controlled or operated at a constant speed, wherein the battery charging current from the U101 is controlled to change the output power to the load;	OFF	*0-MAX OR CONSTANT SPEED **0-MAX	OFF	ON
F1-D The engine is speed controlled or operated at a constant speed, wherein the U101 generates short cut current to control the output shaft torque, thereby to change the engine speed	OFF	*0-MAX OR CONSTANT SPEED **0-MAX	OFF	ON
F2 The U101 is powered by the battery to change the speed or the rotation direction of the rear section load	ON	STOP	OFF	OFF
F4-A The engine is operated at a preset speed while the U101 is operated as a motor to provide added power output to drive the rear section load	OFF	0-MAX OR CONSTANT SPEED	OFF	ON

TABLE 3-continued

F4-B	The engine is operated at a preset speed while the U101 is operated as a motor to provide added power output to drive the front and rear section loads	OFF	0-MAX	OFF	ON
F5	The U101 is operated as a generator to charge the battery using the recovered rear section kinetic energy	*OFF **ON	*SLOW OR STOP **STOP-MAX	OFF	*ON **OFF
F7	All the loads are braked by the engine friction damping	OFF	SLOW OR STOP	OFF	ON
F8	The system is self charged (It can be stopped at a preset time or controlled by the capacity) through that the U101 is driven by the engine to be operated as a generator to charge the battery or to provide varied or constant frequency AC generation output	OFF	0-MAX OR CONSTANT SPEED	OFF	ON
F9	The U101 is operated as a motor to start the engine	OFF	STOP TO START	OFF	ON
F10	Neutral Slide	OFF	STOP OR 0-MAX	OFF	OFF

FUNCTIONS	COMPONENTS				REMARK
	CL103	G/M (U101)	BT101		
F1-A	The engine fuel valve is controlled to drive the engine from low speed to high speed	*OFF **ON ***ON	*READY **READY ***READY	*READY **READY ***READY	*Drive the rear section load
F1-B	The engine fuel valve and the U101 is controlled simultaneously to drive the engine from low speed to high speed and to charge the battery simultaneously	*OFF **ON ***ON	GEN-	CHARGE	**Drive the front and rear section loads simultaneously
F1-C	The engine is speed controlled or operated at a constant speed, wherein the battery charging current from the U101 is controlled to change the output power to the load;	*OFF **ON	GEN-	DIS- CHARGE	***Drive the front section load
F1-D	The engine is speed controlled or operated at a constant speed, wherein the U101 generates short cut current to control the output shaft torque, thereby to change the engine speed	*OFF **ON	GEN-	READY	
F2	The U101 is powered by the battery to change the speed or the rotation direction of the rear section load	OFF	MOTOR	DIS- CHARGE	
F4-A	The engine is operated at a preset speed while the U101 is operated as a motor to provide added power output to drive the rear section load	OFF	MOTOR	DIS- CHARGE	
F4-B	The engine is operated at a preset speed while the U101 is operated as a motor to provide added power output to drive the front and rear section loads	ON	MOTOR	DIS- CHARGE	
F5	The U101 is operated as a generator to charge the battery using the recovered rear section kinetic energy	OFF	GEN-	CHARGE	*The engine piston friction damping is activated simultaneously
F7	All the loads are braked by the engine friction damping	ON	READY	READY	**Recovery of the kinetic energy
F8	The system is self charged (It can be stopped at a preset time or controlled by the capacity) through that the U101 is driven by the engine to be operated as a generator to charge the battery or to provide varied or constant frequency AC generation output	OFF	GEN-	CHARGE	The operation is limited to when the engine is stopped and the rear load brake is locked.
F9	The U101 is operated as a motor to start the engine	OFF	MOTOR	DIS- CHARGE	
F10	Neutral Slide	OFF	READY	READY	

Notes:

- 1) CHARGE current of F1-B is load following distributed
- 2) The U101 is an electrical machine
- 3) BT101 is the battery
- 4) GEN- is a generator
- 5) For the case of engine, the P101 is the drive side rotational power source which is employed to drive the front section load and is series combined with the U101 to drive the rear section load
- 6) For the case of AC power output function in F8, the said U101 is selected to employ the electrical machine with AC power generating functions comprised of a permanent magnet or winding excited, varied frequency driven field type electrical device, or a brushed alternator type electrical device, wherein its armature winding is commonly installed the conducting rings for AC output and the commutators for DC input/output.

TABLE 4

FUNCTIONS	COMPONENTS		
	B101	P101	CL102
F1-A The engine fuel valve is controlled to drive the engine from low speed to high speed	OFF	0-MAX	ON
F1-B The engine fuel valve and the U101 is controlled simultaneously to drive the engine from low speed to high speed and to charge the battery simultaneously	OFF	0-MAX	ON
F1-C The engine is speed controlled or operated at a constant speed, wherein the battery charging current from the U101 is controlled to change the output power to the load;	OFF	*0-MAX OR CONSTANT SPEED **0-MAX	ON
F1-D The engine is speed controlled or operated at a constant speed, wherein the U101 generates short cut current to control the output shaft torque, thereby to change the engine speed	OFF	*0-MAX OR CONSTANT SPEED **0-MAX	ON
F2 The U101 is powered by the battery to change the speed or the rotation direction of the rear section load	ON	STOP	OFF
F4-A The engine is operated at a preset speed while the U101 is operated as a motor to provide added power output to drive the rear section load	OFF	0-MAX OR CONSTANT SPEED	ON
F4-B The engine is operated at a preset speed while the U101 is operated as a motor to provide added power output to drive the front and rear section loads	OFF	0-MAX CONSTANT SPEED	ON
F5 The U101 is operated as a generator to charge the battery using the recovered rear section kinetic energy	*OFF **ON	*SLOW OR STOP **STOP-MAX	*ON **OFF
F6 The U101 is operated as a generator to charge the battery using the recovered front section kinetic energy	OFF	*SLOW OR STOP **STOP-MAX	*ON **OFF
F7 All the loads are braked by the engine friction damping	OFF	SLOW OR STOP	ON
F8 The system is self charged (It can be stopped at a preset time or controlled by the capacity) through that the U101 is driven by the engine to be operated as a generator to charge the battery or to provide varied or constant frequency AC generation output	OFF	0-MAX OR CONSTANT SPEED	ON
F9 The U101 is operated as a motor to start the engine	OFF	STOP TO START	ON
F10 Neutral Slide	OFF	STOP OR 0-MAX	OFF

FUNCTIONS	COMPONENTS				
	CL103	CL104	G/M (U101)	BT101	REMARK
F1-A The engine fuel valve is controlled to drive the engine from low speed to high speed	*OFF **ON ***ON	*ON **ON ***OFF	*READY **READY ***READY	*READY **READY ***READY	*Drive the rear section load
F1-B The engine fuel valve and the U101 is controlled simultaneously to drive the engine from low speed to high speed and to charge the battery simultaneously	*OFF **ON ***ON	*ON **ON ***OFF	GEN-	CHARGE	**Drive the front and rear section loads simultaneously ***Drive the front section load
F1-C The engine is speed controlled or operated at a constant speed, wherein the battery charging current from the U101 is controlled to change the output power to the load;	*OFF **ON	ON	GEN-	DIS- CHARGE	loads simultaneously ***Drive the front section load
F1-D The engine is speed controlled or operated at a constant speed, wherein the U101 generates short cut current to control the output shaft torque, thereby to change the engine speed	*OFF **ON	ON	GEN-	READY	the front section load
F2 The U101 is powered by the battery to change the speed or the rotation direction of the rear section load	OFF	ON	MOTOR	DIS- CHARGE	
F4-A The engine is operated at a preset speed while the U101 is operated as a motor to provide added power output to drive the rear section load	OFF	ON	MOTOR	DIS- CHARGE	
F4-B The engine is operated at a preset speed while the U101 is operated as a motor to provide added power output to drive the front and rear section loads	ON	ON	MOTOR	DIS- CHARGE	
F5 The U101 is operated as a generator to charge the battery using the recovered rear section kinetic energy	OFF	ON	GEN-	CHARGE	*The engine piston friction damping is activated simultaneously **Recovery of the kinetic energy
F6 The U101 is operated as a generator to charge the battery using the recovered front section kinetic energy	ON	OFF	GEN-	CHARGE	

TABLE 4-continued

F7	All the loads are braked by the engine friction damping	ON	ON	READY	READY
F8	The system is self charged (It can be stopped at a preset time or controlled by the capacity) through that the U101 is driven by the engine to be operated as a generator to charge the battery or to provide varied or constant frequency AC generation output	OFF	OFF	GEN-	CHARGE
F9	The U101 is operated as a motor to start the engine	OFF	OFF	MOTOR	DIS-CHARGE
F10	Neutral Slide	OFF	OFF	READY	READY

Notes:

- 1) CHARGE current of F1-B is load following distributed
- 2) The U101 is an electrical machine
- 3) BT101 is the battery
- 4) GEN- is a generator
- 5) For the case of engine, the P101 is the drive side rotational power source which is employed to drive the front section load and is series combined with the U101 to drive the rear section load
- 6) For the case of AC power output function in F8, the said U101 is selected to employ the electrical machine with AC power generating functions comprised of a permanent magnet or winding excited, varied frequency driven field type electrical device, or a brushed alternator type electrical device, wherein its armature winding is commonly installed the conducting rings for AC output and the commutators for DC input/output.

TABLE 5

FUNCTIONS	COMPONENTS		
	B101	B102	P101
F1-A The engine fuel valve is controlled to drive the engine from low speed to high speed	OFF	*OFF **OFF ***OFF	0-MAX
F1-B The engine fuel valve and the U101 is controlled simultaneously to drive the engine from low speed to high speed and to charge the battery simultaneously	OFF	*OFF **OFF ***OFF	0-MAX
F1-C The engine is speed controlled or operated at a constant speed, wherein the battery charging current from the U101 is controlled to change the output power to the load;	OFF	OFF	*0-MAX OR CONSTANT SPEED **0-MAX
F1-D The engine is speed controlled or operated at a constant speed, wherein the U101 generates short cut current to control the output shaft torque, thereby to change the engine speed	OFF	OFF	*0-MAX OR CONSTANT SPEED **0-MAX
F2 The U101 is powered by the battery to change the speed or the rotation direction of the rear section load	ON	OFF	STOP
F3 The U101 is powered by the battery to change the speed or the rotation direction of the front section load	OFF	ON	STOP
F4-A The engine is operated at a preset speed while the U101 is operated as a motor to provide added power output to drive the rear section load	OFF	OFF	0-MAX OR CONSTANT SPEED
F4-B The engine is operated at a preset speed while the U101 is operated as a motor to provide added power output to drive the front and rear section loads	OFF	OFF	0-MAX
F5 The U101 is operated as a generator to charge the battery using the recovered rear section kinetic energy	*OFF **ON	OFF	*SLOW OR STOP **STOP-MAX
F6 The U101 is operated as a generator to charge the battery using the recovered front section kinetic energy	OFF	ON	*SLOW OR STOP **STOP-MAX
F7 All the loads are braked by the engine friction damping	OFF	OFF	SLOW OR STOP
F8 The system is self charged (It can be stopped at a preset time or controlled by the capacity) through that the U101 is driven by the engine to be operated as a generator to charge the battery or to provide varied or constant frequency AC generation output	OFF	ON	0-MAX OR CONSTANT SPEED
F9 The U101 is operated as a motor to start the engine	OFF	ON	STOP TO START
F10 Neutral Slide	OFF	OFF	STOP OR 0-MAX
F11 The engine is used to drive the front section load, and the U101 is used to drive the rear section load, and both are independently operated	ON	OFF	0-MAX
F12 The engine is used to drive the front section load and the U101 is pulled to be operated as a generator to charge the battery.	ON	OFF	0-MAX

FUNCTION	COMPONENTS				
	CL101	CL102	CL103	CL104	CL105
F1-A The engine fuel valve is controlled to drive the engine from low speed to high speed	*ON **ON ***OFF	ON	*OFF **ON ***ON	*ON **ON ***OFF	*ON **ON ***OFF

TABLE 5-continued

F1-B	The engine fuel valve and the U101 is controlled simultaneously to drive the engine from low speed to high speed and to charge the battery simultaneously	*OFF	ON	*OFF **ON ***ON	*ON **ON ***OFF	*ON **ON ***OFF
F1-C	The engine is speed controlled or operated at a constant speed, wherein the battery charging current from the U101 is controlled to change the output power to the load;	OFF	ON	*OFF **ON	ON	ON
F1-D	The engine is speed controlled or operated at a constant speed, wherein the U101 generates short cut current to control the output shaft torque, thereby to change the engine speed	OFF	ON	*OFF **ON	ON	ON
F2	The U101 is powered by the battery to change the speed or the rotation direction of the rear section load	OFF	OFF	OFF	ON	ON
F3	The U101 is powered by the battery to change the speed or the rotation direction of the front section load	OFF	OFF	ON	OFF	OFF
F4-A	The engine is operated at a preset speed while the U101 is operated as a motor to provide added power output to drive the rear section load	OFF	ON	OFF	ON	ON
F4-B	The engine is operated at a preset speed while the U101 is operated as a motor to provide added power output to drive the front and rear section loads	OFF	ON	ON	ON	ON
F5	The U101 is operated as a generator to charge the battery using the recovered rear section kinetic energy	OFF	*ON **OFF	OFF	ON	ON
F6	The U101 is operated as a generator to charge the battery using the recovered front section kinetic energy	OFF	*ON **OFF	ON	OFF	OFF
F7	All the loads are braked by the engine friction damping	OFF	ON	ON	ON	ON
F8	The system is self charged (It can be stopped at a preset time or controlled by the capacity) through that the U101 is driven by the engine to be operated as a generator to charge the battery or to provide varied or constant frequency AC generation output	OFF	ON	OFF	OFF	OFF
F9	The U101 is operated as a motor to start the engine	OFF	ON	OFF	OFF	OFF
F10	Neutral Slide	OFF	OFF	OFF	OFF	OFF
F11	The engine is used to drive the front section load, and the U101 is used to drive the rear section load, and both are independently operated	OFF	ON	ON	ON	OFF
F12	The engine is used to drive the front section load and the U101 is pulled to be operated as a generator to charge the battery.	OFF	ON	ON	ON	OFF

FUNCTIONS	COMPONENTS		
	G/M (U101)	BT101	REMARK
F1-A The engine fuel valve is controlled to drive the engine from low speed to high speed	*READY **READY ***READY	*READY **READY ***READY	*Drive the rear section load
F1-B The engine fuel valve and the U101 is controlled simultaneously to drive the engine from low speed to high speed and to charge the battery simultaneously	GEN-	CHARGE	**Drive the front and rear section loads simultaneously
F1-C The engine is speed controlled or operated at a constant speed, wherein the battery charging current from the U101 is controlled to change the output power to the load;	GEN-	DIS-CHARGE	***Drive the front section load
F1-D The engine is speed controlled or operated at a constant speed, wherein the U101 generates short cut current to control the output shaft torque, thereby to change the engine speed	GEN-	READY	
F2 The U101 is powered by the battery to change the speed or the rotation direction of the rear section load	MOTOR	DIS-CHARGE	
F3 The U101 is powered by the battery to change the speed or the rotation direction of the front section load	MOTOR	DIS-CHARGE	
F4-A The engine is operated at a preset speed while the U101 is operated as a motor to provide added power output to drive the rear section load	MOTOR	DIS-CHARGE	
F4-B The engine is operated at a preset speed while the U101 is operated as a motor to provide added power output to drive the front and rear section loads	MOTOR	DIS-CHARGE	
F5 The U101 is operated as a generator to charge the battery using the recovered rear section kinetic energy	GEN-	CHARGE	*The engine piston friction damping is activated simultaneously
F6 The U101 is operated as a generator to charge the battery using the recovered front section kinetic energy	GEN-	CHARGE	**Recovery of the kinetic energy

TABLE 5-continued

F7	All the loads are braked by the engine friction damping	READY	READY
F8	The system is self charged (It can be stopped at a preset time or controlled by the capacity) through that the U101 is driven by the engine to be operated as a generator to charge the battery or to provide varied or constant frequency AC generation output	GEN-	CHARGE
F9	The U101 is operated as a motor to start the engine	MOTOR	DIS-CHARGE
F10	Neutral Slide	READY	READY
F11	The engine is used to drive the front section load, and the U101 is used to drive the rear section load, and both are independently operated	MOTOR	DIS-CHARGE
F12	The engine is used to drive the front section load and the U101 is pulled to be operated as a generator to charge the battery.	GEN-	CHARGE

Notes:

- 1) CHARGE current of F1-B is load following distributed
- 2) The U101 is an electrical machine
- 3) BT101 is the battery
- 4) GEN- is a generator
- 5) For the case of engine, the P101 is the drive side rotational power source which is employed to drive the front section load and is series combined with the U101 to drive the rear section load
- 6) For the case of AC power output function in F8, the said U101 is selected to employ the electrical machine with AC power generating functions comprised of a permanent magnet or winding excited, varied frequency driven field type electrical device, or a brushed alternator type electrical device, wherein its armature winding is commonly installed the conducting rings for AC output and the commutators for DC input/output.

TABLE 6

FUNCTIONS	COMPONENTS		
	B101	B102	P101
F1-A The engine fuel valve is controlled to drive the engine from low speed to high speed	OFF	*OFF **OFF ***OFF	0-MAX
F1-B The engine fuel valve and the U101 is controlled simultaneously to drive the engine from low speed to high speed and to charge the battery simultaneously	OFF	*OFF **OFF ***ON	0-MAX
F1-C The engine is speed controlled or operated at a constant speed, wherein the battery charging current from the U101 is controlled to change the output power to the load;	OFF	OFF	*0-MAX OR CONSTANT SPEED **0-MAX
F1-D The engine is speed controlled or operated at a constant speed, wherein the U101 generates short cut current to control the output shaft torque, thereby to change the engine speed	OFF	OFF	*0-MAX OR CONSTANT SPEED **0-MAX
F2 The U101 is powered by the battery to change the speed or the rotation direction of the rear section load	ON	OFF	STOP
F4-A The engine is operated at a preset speed while the U101 is operated as a motor to provide added power output to drive the rear section load	OFF	OFF	0-MAX OR CONSTANT SPEED
F4-B The engine is operated at a preset speed while the U101 is operated as a motor to provide added power output to drive the front and rear section loads	OFF	OFF	0-MAX
F5 The U101 is operated as a generator to charge the battery using the recovered rear section kinetic energy	*OFF **ON	OFF	*SLOW OR STOP **STOP-MAX
F7 All the loads are braked by the engine friction damping	OFF	OFF	SLOW OR STOP
F8 The system is self charged (It can be stopped at a preset time or controlled by the capacity) through that the U101 is driven by the engine to be operated as a generator to charge the battery or to provide varied or constant frequency AC generation output	OFF	ON	0-MAX OR CONSTANT SPEED
F9 The U101 is operated as a motor to start the engine	OFF	ON	STOP TO START
F10 Neutral Slide	OFF	OFF	STOP OR 0-MAX
F11 The engine is used to drive the front section load, and the U101 is used to drive the rear section load, and both are independently operated	ON	OFF	0-MAX
F12 The engine is used to drive the front section load and the U101 is pulled to be operated as a generator to charge the battery.	ON	OFF	0-MAX

FUNCTION	COMPONENTS			
	B103	CL102	CL103	CL105
F1-A The engine fuel valve is controlled to drive the engine from low speed to high speed	*ON **ON ***OFF	ON	*OFF **ON ***ON	*ON **ON ***OFF

TABLE 6-continued

F1-B	The engine fuel valve and the U101 is controlled simultaneously to drive the engine from low speed to high speed and to charge the battery simultaneously	*OFF	ON	*OFF **ON ***ON	*ON **ON ***OFF
F1-C	The engine is speed controlled or operated at a constant speed, wherein the battery charging current from the U101 is controlled to change the output power to the load;	OFF	ON	*OFF **ON	ON
F1-D	The engine is speed controlled or operated at a constant speed, wherein the U101 generates short cut current to control the output shaft torque, thereby to change the engine speed	OFF	ON	*OFF **ON	ON
F2	The U101 is powered by the battery to change the speed or the rotation direction of the rear section load	OFF	OFF	OFF	OFF
F4-A	The engine is operated at a preset speed while the U101 is operated as a motor to provide added power output to drive the rear section load	OFF	ON	OFF	ON
F4-B	The engine is operated at a preset speed while the U101 is operated as a motor to provide added power output to drive the front and rear section loads	OFF	ON	ON	ON
F5	The U101 is operated as a generator to charge the battery using the recovered rear section kinetic energy	OFF	*ON **OFF	OFF	*ON **OFF
F7	All the loads are braked by the engine friction damping	OFF	ON	ON	ON
F8	The system is self charged (It can be stopped at a preset time or controlled by the capacity) through that the U101 is driven by the engine to be operated as a generator to charge the battery or to provide varied or constant frequency AC generation output	OFF	ON	OFF	ON
F9	The U101 is operated as a motor to start the engine	OFF	ON	OFF	ON
F10	Neutral Slide	OFF	OFF	OFF	OFF
F11	The engine is used to drive the front section load, and the U101 is used to drive the rear section load, and both are independently operated	OFF	ON	ON	OFF
F12	The engine is used to drive the front section load and the U101 is pulled to be operated as a generator to charge the battery.	OFF	ON	ON	OFF

FUNCTIONS	COMPONENTS			REMARK
	G/M (U101)	BT101		
F1-A	The engine fuel valve is controlled to drive the engine from low speed to high speed	*READY **READY ***READY	*READY **READY ***READY	*Drive the rear section load
F1-B	The engine fuel valve and the U101 is controlled simultaneously to drive the engine from low speed to high speed and to charge the battery simultaneously	GEN-	CHARGE	**Drive the front and rear section loads simultaneously
F1-C	The engine is speed controlled or operated at a constant speed, wherein the battery charging current from the U101 is controlled to change the output power to the load;	GEN-	DIS-CHARGE	***Drive the front section load
F1-D	The engine is speed controlled or operated at a constant speed, wherein the U101 generates short cut current to control the output shaft torque, thereby to change the engine speed	GEN-	READY	
F2	The U101 is powered by the battery to change the speed or the rotation direction of the rear section load	MOTOR	DIS-CHARGE	
F4-A	The engine is operated at a preset speed while the U101 is operated as a motor to provide added power output to drive the rear section load	MOTOR	DIS-CHARGE	
F4-B	The engine is operated at a preset speed while the U101 is operated as a motor to provide added power output to drive the front and rear section loads	MOTOR	DIS-CHARGE	
F5	The U101 is operated as a generator to charge the battery using the recovered rear section kinetic energy	GEN-	CHARGE	*The engine piston friction damping is activated simultaneously **Recovery of the kinetic energy
F7	All the loads are braked by the engine friction damping	READY	READY	
F8	The system is self charged (It can be stopped at a preset time or controlled by the capacity) through that the U101 is driven by the engine to be operated as a generator to charge the battery or to provide varied or constant frequency AC generation output	GEN-	CHARGE	The operation is limited to when the engine is

TABLE 6-continued

F9	The U101 is operated as a motor to start the engine	MOTOR	DIS-CHARGE	stopped
F10	Neutral Slide	READY	READY	
F11	The engine is used to drive the front section load, and the U101 is used to drive the rear section load, and both are independently operated	MOTOR	DIS-CHARGE	
F12	The engine is used to drive the front section load and the U101 is pulled to be operated as a generator to charge the battery.	GEN-	CHARGE	

Notes:

- 1) CHARGE current of F1-B is load following distributed
- 2) The U101 is an electrical machine
- 3) BT101 is the battery
- 4) GEN- is a generator
- 5) For the case of engine, the P101 is the drive side rotational power source which is employed to drive the front section load and is series combined with the U101 to drive the rear section load
- 6) For the case of AC power output function in F8, the said U101 is selected to employ the electrical machine with AC power generating functions comprised of a permanent magnet or winding excited, varied frequency driven field type electrical device, or a brushed alternator type electrical device, wherein its armature winding is commonly installed the conducting rings for AC output and the commutators for DC input/output.

TABLE 7

FUNCTIONS	COMPONENTS		
	B101	P101	B103
F1-A The engine fuel valve is controlled to drive the engine from low speed to high speed	OFF	0-MAX	*ON **ON ***OFF
F1-B The engine fuel valve and the U101 is controlled simultaneously to drive the engine from low speed to high speed and to charge the battery simultaneously	OFF	0-MAX	*OFF
F1-C The engine is speed controlled or operated at a constant speed, wherein the battery charging current from the U101 is controlled to change the output power to the load;	OFF	*0-MAX OR CONSTANT SPEED **0-MAX	OFF
F1-D The engine is speed controlled or operated at a constant speed, wherein the U101 generates short cut current to control the output shaft torque, thereby to change the engine speed	OFF	*0-MAX OR CONSTANT SPEED **0-MAX	OFF
F2 The U101 is powered by the battery to change the speed or the rotation direction of the rear section load	ON	STOP	OFF
F4-A The engine is operated at a preset speed while the U101 is operated as a motor to provide added power output to drive the rear section load	OFF	0-MAX OR CONSTANT SPEED	OFF
F4-B The engine is operated at a preset speed while the U101 is operated as a motor to provide added power output to drive the front and rear section loads	OFF	0-MAX	OFF
F5 The U101 is operated as a generator to charge the battery using the recovered rear section kinetic energy	*OFF **ON	*SLOW OR STOP **STOP-MAX	OFF
F7 All the loads are braked by the engine friction damping	OFF	SLOW OR STOP	OFF
F8 The system is self charged (It can be stopped at a preset time or controlled by the capacity) through that the U101 is driven by the engine to be operated as a generator to charge the battery or to provide varied or constant frequency AC generation output	OFF	0-MAX OR CONSTANT SPEED	OFF
F9 The U101 is operated as a motor to start the engine	OFF	STOP TO START	OFF
F10 Neutral Slide	OFF	STOP OR 0-MAX	OFF
F11 The engine is used to drive the front section load, and the U101 is used to drive the rear section load, and both are independently operated	ON	0-MAX	OFF
F12 The engine is used to drive the front section load and the U101 is pulled to be operated as a generator to charge the battery.	ON	0-MAX	OFF

FUNCTION	COMPONENTS		
	CL102	CL103	CL105
F1-A The engine fuel valve is controlled to drive the engine from low speed to high speed	ON	*OFF **ON ***ON	*ON **ON ***OFF
F1-B The engine fuel valve and the U101 is controlled simultaneously to drive the engine from low speed to high speed and to charge the battery simultaneously	ON	*OFF **ON ***ON	*ON **ON ***OFF
F1-C The engine is speed controlled or operated at a constant speed, wherein the battery charging current from the U101 is controlled to change the output power to the load;	ON	*OFF **ON	ON

TABLE 7-continued

F1-D	The engine is speed controlled or operated at a constant speed, wherein the U101 generates short cut current to control the output shaft torque, thereby to change the engine speed	ON	*OFF **ON	ON
F2	The U101 is powered by the battery to change the speed or the rotation direction of the rear section load	OFF	OFF	OFF
F4-A	The engine is operated at a preset speed while the U101 is operated as a motor to provide added power output to drive the rear section load	ON	OFF	ON
F4-B	The engine is operated at a preset speed while the U101 is operated as a motor to provide added power output to drive the front and rear section loads	ON	ON	ON
F5	The U101 is operated as a generator to charge the battery using the recovered rear section kinetic energy	*ON **OFF	OFF	*ON **OFF
F7	All the loads are braked by the engine friction damping	ON	ON	ON
F8	The system is self charged (It can be stopped at a preset time or controlled by the capacity) through that the U101 is driven by the engine to be operated as a generator to charge the battery or to provide varied or constant frequency AC generation output	ON	OFF	ON
F9	The U101 is operated as a motor to start the engine	ON	OFF	ON
F10	Neutral Slide	OFF	OFF	OFF
F11	The engine is used to drive the front section load, and the U101 is used to drive the rear section load, and both are independently operated	ON	ON	OFF
F12	The engine is used to drive the front section load and the U101 is pulled to be operated as a generator to charge the battery.	ON	ON	OFF

		COMPONENTS		
FUNCTIONS		G/M (U101)	BT101	REMARK
F1-A	The engine fuel valve is controlled to drive the engine from low speed to high speed	*READY **READY ***READY	*READY **READY ***READY	*Drive the rear section load
F1-B	The engine fuel valve and the U101 is controlled simultaneously to drive the engine from low speed to high speed and to charge the battery simultaneously	GEN-	CHARGE	**Drive the front and rear section loads
F1-C	The engine is speed controlled or operated at a constant speed, wherein the battery charging current from the U101 is controlled to change the output power to the load;	GEN-	DIS-CHARGE	loads simultaneously
F1-D	The engine is speed controlled or operated at a constant speed, wherein the U101 generates short cut current to control the output shaft torque, thereby to change the engine speed	GEN-	READY	***Drive the front section load
F2	The U101 is powered by the battery to change the speed or the rotation direction of the rear section load	MOTOR	DIS-CHARGE	
F4-A	The engine is operated at a preset speed while the U101 is operated as a motor to provide added power output to drive the rear section load	MOTOR	DIS-CHARGE	
F4-B	The engine is operated at a preset speed while the U101 is operated as a motor to provide added power output to drive the front and rear section loads	MOTOR	DIS-CHARGE	
F5	The U101 is operated as a generator to charge the battery using the recovered rear section kinetic energy	GEN-	CHARGE	*The engine piston friction damping is activated simultaneously **Recovery of the kinetic energy
F7	All the loads are braked by the engine friction damping	READY	READY	
F8	The system is self charged (It can be stopped at a preset time or controlled by the capacity) through that the U101 is driven by the engine to be operated as a generator to charge the battery or to provide varied or constant frequency AC generation output	GEN-	CHARGE	The operation is limited to when the engine is stopped and the rear load brake is locked.
F9	The U101 is operated as a motor to start the engine	MOTOR	DIS-CHARGE	

TABLE 7-continued

F10	Neutral Slide	READY	READY
F11	The engine is used to drive the front section load, and the U101 is used to drive the rear section load, and both are independently operated	MOTOR	DIS-CHARGE
F12	The engine is used to drive the front section load and the U101 is pulled to be operated as a generator to charge the battery.	GEN-	CHARGE

Notes:

- 1) CHARGE current of F1-B is load following distributed
- 2) The U101 is an electrical machine
- 3) BT101 is the battery
- 4) GEN- is a generator
- 5) For the case of engine, the P101 is the drive side rotational power source which is employed to drive the front section load and is series combined with the U101 to drive the rear section load
- 6) For the case of AC power output function in F8, the said U101 is selected to employ the electrical machine with AC power generating functions comprised of a permanent magnet or winding excited, varied frequency driven field type electrical device, or a brushed alternator type electrical device, wherein its armature winding is commonly installed the conducting rings for AC output and the commutators for DC input/output.

TABLE 8

FUNCTIONS	COMPONENTS			
	B101	P101	C102	CL103
F1-A The engine fuel valve is controlled to drive the engine from low speed to high speed	OFF	0-MAX	ON	*OFF **ON ***ON
F1-B The engine fuel valve and the U101 is controlled simultaneously to drive the engine from low speed to high speed and to charge the battery simultaneously	OFF	0-MAX	ON	*OFF **ON ***ON
F1-C The engine is speed controlled or operated at a constant speed, wherein the battery charging current from the U101 is controlled to change the output power to the load;	OFF	*0-MAX OR CONSTANT SPEED **0-MAX	ON	*OFF **ON
F1-D The engine is speed controlled or operated at a constant speed, wherein the U101 generates short cut current to control the output shaft torque, thereby to change the engine speed	OFF	*0-MAX OR CONSTANT SPEED **0-MAX	ON	*OFF **ON
F2 The U101 is powered by the battery to change the speed or the rotation direction of the rear section load	ON	STOP	OFF	OFF
F4-A The engine is operated at a preset speed while the U101 is operated as a motor to provide added power output to drive the rear section load	OFF	0-MAX OR CONSTANT SPEED	ON	OFF
F4-B The engine is operated at a preset speed while the U101 is operated as a motor to provide added power output to drive the front and rear section loads	OFF	0-MAX	ON	ON
F5 The U101 is operated as a generator to charge the battery using the recovered rear section kinetic energy	*OFF **ON	*SLOW OR STOP **STOP-MAX	*ON **OFF	OFF
F7 All the loads are braked by the engine friction damping	OFF	SLOW OR STOP	ON	ON
F8 The system is self charged (It can be stopped at a preset time or controlled by the capacity) through that the U101 is dried by the engine to be operated as a generator to charge the battery or to provide varied or constant frequency AC generation output	OFF	0-MAX OR CONSTANT SPEED	ON	OFF
F9 The U101 is operated as a motor to start the engine	OFF	STOP TO START	ON	OFF
F10 Neutral Slide	OFF	STOP OR 0-MAX	OFF	OFF
F11 The engine is used to drive the front section load, and the U101 is used to drive the rear section load, and both are independently operated	ON	0-MAX	ON	ON
F12 The engine is used to drive the front section load and the U101 is pulled to be operated as a generator to charge the battery.	ON	0-MAX	ON	ON

FUNCTIONS	COMPONENTS			
	CL105	G/M (U101)	BT101	REMARK
F1-A The engine fuel valve is controlled to drive the engine from low speed to high speed	*OFF **ON ***OFF	*READY **READY ***READY	*READY **READY ***READY	*Drive the rear section load
F1-B The engine fuel valve and the U101 is controlled simultaneously to drive the engine from low speed to high speed and to charge the battery simultaneously	*ON **ON ***OFF	GEN-	CHARGE	**Drive the front and rear section loads
F1-C The engine is speed controlled or operated at a constant speed, wherein the battery charging current from the U101 is controlled to change the output power to the load;	ON	GEN-	DIS-CHARGE	simultaneously ***Drive

TABLE 8-continued

F1-D	The engine is speed controlled or operated at a constant speed, wherein the U101 generates short cut current to control the output shaft torque, thereby to change the engine speed	ON	GEN-	READY	the front section load
F2	The U101 is powered by the battery to change the speed or the rotation direction of the rear section load	OFF	MOTOR	DIS-CHARGE	
F4-A	The engine is operated at a preset speed while the U101 is operated as a motor to provide added power output to drive the rear section load	ON	MOTOR	DIS-CHARGE	
F4-B	The engine is operated at a preset speed while the U101 is operated as a motor to provide added power output to drive the front and rear section loads	ON	MOTOR	DIS-CHARGE	
F5	The U101 is operated as a generator to charge the battery using the recovered rear section kinetic energy	*ON **OFF	GEN-	CHARGE	*The engine piston friction damping is activated simultaneously **Recovery of the kinetic energy
F7	All the loads are braked by the engine friction damping	ON	READY	READY	
F8	The system is self charged (It can be stopped at a preset time or controlled by the capacity) through that the U101 is driven by the engine to be operated as a generator to charge the battery or to provide varied or constant frequency AC generation output	ON	GEN-	CHARGE	The operation is limited to when the engine is stopped and the rear load brake is locked.
F9	The U101 is operated as a motor to start the engine	ON	MOTOR	DIS-CHARGE	
F10	Neutral Slide	OFF	READY	READY	
F11	The engine is used to drive the front section load, and the U101 is used to drive the rear section load, and both are independently operated	OFF	MOTOR	DIS-CHARGE	
F12	The engine is used to drive the front section load and the U101 is pulled to be operated as a generator to charge the battery.	OFF	GEN-	CHARGE	

Notes:

- 1) CHARGE current of F1-B is load following distributed
- 2) The U101 is an electrical machine
- 3) BT101 is the battery
- 4) GEN- is a generator
- 5) For the case of engine, the P101 is the drive side rotational power source which is employed to drive the front section load and is series combined with the U101 to drive the rear section load
- 6) For the case of AC power output function in F8, the said U101 is selected to employ the electrical machine with AC power generating functions comprised of a permanent magnet or winding excited, varied frequency driven field type electrical device, or a brushed alternator type electrical device, wherein its armature winding is commonly installed the conducting rings for AC output and the commutators for DC input/output.

I claim:

1. A differential mixing combined power distribution system for use in rotational driving applications, 50
a rotational output shaft of a rotational power source coupled to drive a front section load, and also coupled with the input shaft of a different mixing drive unit to drive a differentially acting two-sided rear section load, wherein the differential mixing drive device comprises an 55
electrical machine combined with a differential gear transmission system; and
further comprising a brake installed between a rotor and a stator of the electrical machine, and means for controlling the brake to generate motor driving functions 60
when an input current is applied and the electric machine is employed as a motor, or to generate variable speed coupling functions through an output current when the electrode machine is employed as a generator, the electric machine also being used for starting the 65
engine and as a power regeneration brake when the engine is the main power source for the front and rear

section loads, the electric machine being connected to charge the battery at which time a speed difference with the rear load section can be adjusted by controlling the charging current,

wherein the rotational power source can be driven at a constant speed and at a partially adjustable speed to improve operating efficiency and decrease pollution, with one part of the differential speed output power generated through the differential mixing drive device being used for driving the load while the remainder of the output power is converted through the generator function of the electrical machine of the differential mixing drive device to charge the battery.

2. A differential mixing combined power distribution system, comprising:

a drive side rotational power source (P101) having an output which is first supplied to a front section load and is then transmitted to an input end of a differential mixing drive device (M101) to drive a rear section load;

the drive side rotational power source (P101) including a rotational output shaft (S102) coupled to a middle

transmission device and a control interface (M102) through a clutch (CL102), the rotational power source further including a speed sensor (SD101) to transmit the engine rotation signal to a central controller (CCU101) and a controllable fuel valve (CG101) controlled by the central controller (CCU101) to carry out the functions of changing the engine speed and keeping the engine maintained at a constant speed;

the middle transmission device and control interface (M102) including a speed change control system for driving the front section lead only and also for driving both loads;

a middle input shaft (S101) coupled at the output end of the clutch (CL102);

a brake (B101) controlled by the central controller CCU101 and installed between the middle shaft (S101) and a fixed casing;

a differential mixing drive device (M101) including an electric machine (U101) connected to a battery (BT101) and combined with a differential transmission system coupled with the transmission middle shaft (S101) and driven by the drive side rotational power unit, and also coupled with the input shaft of the rear differential gear box (GB101) through a clutch (CL104) to drive the rear section lead;

a drive circuit (D101) installed between the electrical machine (UB101) and the battery (BT101) and arranged to receive operating commands from the central controller (CCU101) to control the electrical machine (U101) to at least carry out the functions of driving the front section lead, starting the engine, and providing power generation at standstill, the electrical machine (U101) being driven by the engine at standstill to function as a generator to charge the battery and supply power to any other loads connected thereto.

3. A system as claimed in claim 2, wherein the electrical machine is arranged such that a rotational speed of the rotor is increased with a decreasing load on the rotor.

4. A system as claimed in claim 2, wherein the electrical machine is arranged to be controlled by the drive circuit (D101) to provide additional torque on a driven load.

5. A system as claimed in claim 2, further comprising a brake (B103) installed between a rotor and stator of the electrical machine and arranged to be controlled by the central controller (CCU101) to thereby provide a direct mechanical synchronous interlock for the rotor and stator of the electrical machine (U101).

6. A system as claimed in claim 5, further comprising a brake (B 102) located between the differentially acting output shafts of the differential mixing drive device (M101) and the coupled rear differential gear box.

7. A system as claimed in claim 6, further comprising a clutch (CL104) positioned between the brake (B102) and the rear section load.

8. A system as claimed in claim 5, further comprising a clutch (CL103) installed between the middle input shaft (S101) and the front section load to provide a transmission coupling between the middle transmission device and the front section load.

9. A system as claimed in claim 8, further comprising a brake (B102) located between the differentially acting output shafts of the differential mixing drive device (M101) and the coupled rear differential gear box.

10. A system as claimed in claim 9, further comprising a clutch (CL104) positioned between the brake (B102) and the rear section load.

11. A system as claimed in claim 10, wherein the central controller includes means for causing the system to carry out the following functions:

controlling the engine fuel valve to drive the engine from low speed to high speed;

controlling the engine fuel valve and the electrical machine simultaneously to drive the engine from low speed to high speed and to charge the battery simultaneously;

changing a speed of the engine by causing the electrical machine to generate a current for controlling an output shaft torque;

causing the electrical machine to be powered by the battery to change a rotation direction of the rear section load;

powering the electrical machine by the battery to change a speed or direction of the front section load;

operating the engine at a preset speed while the electrical machine is operated as a motor to provide additional power for driving the rear section load;

operating the engine as a generator to charge the battery using kinetic energy recovered from the rear section load;

operating the electrical machine as a generator to charge the battery using kinetic energy recovered from the front section load;

causing all loads to be braked by engine friction damping; and

causing the electrical machine to be driven by the engine to function as generator for charging the battery and to provide an electrical output to any additional loads connected thereto.

12. A system as claimed in claim 9, wherein the central controller includes means for causing the system to carry out the following functions:

controlling the engine fuel valve to drive the engine from low speed to high speed;

controlling the engine fuel valve and the electrical machine simultaneously to drive the engine from low speed to high speed and to charge the battery simultaneously;

changing a speed of the engine by causing the electrical machine to generate a current for controlling an output shaft torque;

causing the electrical machine to be powered by the battery to change a rotation direction of the rear section load;

operating the engine at a preset speed while the electrical machine is operated as a motor to provide additional power for driving the rear section load;

operating the engine as a generator to charge the battery using kinetic energy recovered from the rear section load;

causing all loads to be braked by engine friction damping; and

causing the electrical machine to be driven by the engine to function as generator for charging the battery and to provide an electrical output to any additional loads connected thereto.

13. The system as in claim 8, wherein the central controller includes means for causing the system to carry out the following functions:

controlling the engine fuel valve to drive the engine from low speed to high speed;

39

controlling the engine fuel valve and the electrical machine simultaneously to drive the engine from low speed to high speed and to charge the battery simultaneously;

changing a speed of the engine by causing the electrical machine to generate a current for controlling an output shaft torque;

causing the electrical machine to be powered by the battery to change a rotation direction of the rear section load;

operating the engine at a present speed while the electrical machine is operated as a motor to provide additional power for driving the rear section load;

operating the engine as a generator to charge the battery using kinetic energy recovered from the rear section load;

causing all loads to be braked by engine friction damping; and

causing the electrical machine to be driven by the engine to function as generator for charging the battery and to provide an electrical output to any additional loads connected thereto.

14. A system as claimed in claim 7, wherein the central controller includes means for causing the system to carry out the following functions:

controlling the engine fuel valve to drive the engine from low speed to high speed;

controlling the engine fuel valve and the electrical machine simultaneously to drive the engine from low speed to high speed and to charge the battery simultaneously;

changing a speed of the engine by causing the electrical machine to generate a current for controlling an output shaft torque;

causing the electrical machine to be powered by the battery to change a rotation direction of the rear section load;

operating the engine at a preset speed while the electrical machine is operated as a motor to provide additional power for driving the rear section load;

operating the engine as a generator to charge the battery using kinetic energy recovered from the rear section load;

operating the engine as a generator to charge the battery using kinetic energy recovered from the front section load;

causing all loads to be braked by engine friction damping; and

causing the electrical machine to be driven by the engine to function as generator for charging the battery and to provide an electrical output to any additional loads connected thereto.

15. A system as claimed in claim 7, further including a clutch (CL105) between the rear section output middle shaft and the middle transmission device, wherein the central controller includes means for causing the system to carry out the following functions:

controlling the engine fuel valve to drive the engine from low speed to high speed;

controlling the engine fuel valve and the electrical machine simultaneously to drive the engine from low speed to high speed and to charge the battery simultaneously;

changing a speed of the engine by causing the electrical machine to generate a current for controlling an output shaft torque;

40

causing the electrical machine to be powered by the battery to change a rotation direction of the rear section load;

causing the electrical machine to be powered by the battery to change a rotation or speed of the front section load;

operating the engine at a preset speed while the electrical machine is operated as a motor to provide additional power for driving the rear section load;

operating the engine as a generator to charge the battery using kinetic energy recovered from the rear section load;

operating the engine as a generator to charge the battery using kinetic energy recovered from the front section load;

causing all loads to be braked by engine friction damping; causing the electrical machine to be driven by the engine to function as generator for charging the battery and to provide an electrical output to any additional loads connected thereto;

operating the engine to drive the front section load and independently operating the electrical machine to drive the rear section load; and

operating the engine to drive the front section load and causing the engine to also drive the electrical machine to charge the battery.

16. A system as claimed in claim 6, further comprising clutch (CL105) between the rear section output middle shaft and the middle transmission device, wherein the central controller includes means for causing the system to carry out the following functions:

controlling the engine fuel valve to drive the engine from low speed to high speed;

controlling the engine fuel valve and the electrical machine simultaneously to drive the engine from low speed to high speed and to charge the battery simultaneously;

changing a speed of the engine by causing the electrical machine to generate a current for controlling an output shaft torque;

causing the electrical machine to be powered by the battery to change a rotation direction of the rear section load;

causing the electrical machine to be powered by the battery to change a rotation or speed of the front section load;

operating the engine at a preset speed while the electrical machine is operated as a motor to provide additional power for driving the rear section load;

operating the engine as a generator to charge the battery using kinetic energy recovered from the rear section load;

causing all loads to be braked by engine friction damping; causing the electrical machine to be driven by the engine to function as generator for charging the battery and to provide an electrical output to any additional loads connected thereto;

operating the engine to drive the front section load and independently operating the electrical machine to drive the rear section load; and

operating the engine to drive the front section load and causing the engine to also drive the electrical machine to charge the battery.

17. A system as claimed in claim 8, further comprising a clutch (CL105) between the rear section output middle shaft

and the middle transmission device, wherein the central controller includes means for causing the system to carry out the following functions:

- controlling the engine fuel valve to drive the engine from low speed to high speed;
- controlling the engine fuel valve and the electrical machine simultaneously to drive the engine from low speed to high speed and to charge the battery simultaneously;
- changing a speed of the engine by causing the electrical machine to generate a current for controlling an output shaft torque;
- causing the electrical machine to be powered by the battery to change a rotation direction of the rear section load;
- causing the electrical machine to be powered by the battery to change a rotation or speed of the front section load;
- operating the engine at a preset speed while the electrical machine is operated as a motor to provide additional power for driving the rear section load;
- operating the engine as a generator to charge the battery using kinetic energy recovered from the rear section load;
- causing all loads to be braked by engine friction damping;
- causing the electrical machine to be driven by the engine to function as generator for charging the battery and to provide an electrical output to any additional loads connected thereto;
- operating the engine to drive the front section load and independently operating the electrical machine to drive the rear section load; and
- operating the engine to drive the front section load and causing the engine to also drive the electrical machine to charge the battery.

18. A system as claimed in claim 2, further comprising a clutch (CL103) installed between the middle input shaft (S101) and the front section load to provide a transmission coupling between the middle transmission device and the front section load, and a clutch (CL105) between the rear section output middle shaft and the middle transmission device, wherein the central controller includes means for causing the system to carry out the following functions:

- controlling the engine fuel valve to drive the engine from low speed to high speed;
- controlling the engine fuel valve and the electrical machine simultaneously to drive the engine from low speed to high speed and to change the battery simultaneously;
- changing a speed of the engine by causing the electrical machine to generate a current for controlling an output shaft torque;

- causing the electrical machine to be powered by the battery to change a rotation direction of the rear section load;
- causing the electrical machine to be powered by the battery to change a rotation or speed of the front section load;
- operating the engine at a preset speed while the electrical machine is operated as a motor to provide additional power for driving the rear section load;
- operating the engine as a generator to charge the battery using kinetic energy recovered from the rear section load;
- causing all loads to be braked by engine friction damping;
- causing the electrical machine to be driven by the engine to function as generator for charging the battery and to provide an electrical output to any additional loads connected thereto;
- operating the engine to drive the front section load and independently operating the electrical machine to drive the rear section load; and
- operating the engine to drive the front section load and causing the engine to also drive the electrical machine to charge the battery.

19. A system as claimed in claim 2, wherein the front and rear section loads are wheels and relationships between the front and rear section loads is set not to operate according to the wheel system ratio relationship, but to operate through a differentially acting adjustment by the electrical machine (U101).

20. A system as claimed in claim 19, wherein the differentially acting adjustment of the electrical machine (U101) includes an active adjustment of the input power when the electrical machine functions as a motor and a passive adjustment of the output power when the electrical machine functions as a generator.

21. A system as claimed in claim 2, wherein the front section load is one of front and rear sets of wheels of a vehicle, and the rear section load is the other of the front and rear sets of wheels.

22. A system as claimed in claim 2, wherein said transmission gear system includes two differential output shafts and an input shaft coupled with the electrical device through a transmission gear, the two wheel shafts of the differential gears being respectively coupled with a transmission middle shaft driven by the rotational power source and with the input shaft of a rear differential gear box through a clutch to drive the two-side differentially acting rear section load.

23. A system as claimed in claim 2, wherein said transmission gear system comprising a planetary gear train and a friction wheel.

* * * * *