



US00RE37665E

(19) **United States**
(12) **Reissued Patent**
Ralph et al.

(10) **Patent Number:** **US RE37,665 E**
(45) **Date of Reissued Patent:** **Apr. 16, 2002**

(54) **POLYAXIAL PEDICLE SCREW HAVING A
THREADED AND TAPERED COMPRESSION
LOCKING MECHANISM**

5,443,467 A * 8/1995 Biedermann et al. 606/65
5,520,690 A * 5/1996 Errico et al. 606/61
5,607,426 A * 3/1997 Ralph et al. 606/61
5,669,911 A * 9/1997 Errico et al. 606/61

(75) Inventors: **James D. Ralph**, Oakland; **Stephen Tatar**, Montvale, both of NJ (US)

* cited by examiner

(73) Assignee: **Fastenetix, LLC**, Summit, NJ (US)

Primary Examiner—David O. Reip

(21) Appl. No.: **09/774,915**

(74) *Attorney, Agent, or Firm*—Morrison & Foerster, LLP

(22) Filed: **Jan. 30, 2001**

(57) **ABSTRACT**

Related U.S. Patent Documents

Reissue of:

(64) Patent No.: **5,882,350**
Issued: **Mar. 16, 1999**
Appl. No.: **09/002,535**
Filed: **Jan. 2, 1998**

A polyaxial orthopedic device for use with rod implant apparatus includes a screw having a curvate head, a two-piece interlocking coupling element which mounts about the curvate head, and a rod receiving cylindrical body member having a tapered socket into which both the screw and the interlocking coupling element are securely nested. The interlocking coupling element includes a socket portion which is slotted and tapered so that when it is radially compressed by being driven downwardly into the tapered socket in the cylindrical body it crush locks to the screw. The securing of the rod in the body member provides the necessary downward force onto the socket portion through a contact force on the top of the cap portion. Prior to the rod being inserted, therefore, the screw head remains polyaxially free with respect to the coupling element and the body. In a preferred embodiment, the cap portion and the socket portion are formed and coupled in such a way that when the cap portion is compressed toward the socket portion, there is an additional inward radial force applied by the cap portion to the socket portion, thereby enhancing the total locking force onto the head of the screw.

U.S. Applications:

(63) Continuation-in-part of application No. 08/663,383, filed on Jun. 13, 1996, now Pat. No. 5,669,911, which is a continuation-in-part of application No. 08/421,087, filed on Apr. 13, 1995, now Pat. No. 5,520,690.

(51) **Int. Cl.**⁷ **A61B 17/70**

(52) **U.S. Cl.** **606/61; 606/73**

(58) **Field of Search** **606/60, 61, 69, 606/70, 71, 72, 73**

(56) **References Cited**

U.S. PATENT DOCUMENTS

5,207,678 A * 5/1993 Harms et al. 606/61

23 Claims, 9 Drawing Sheets

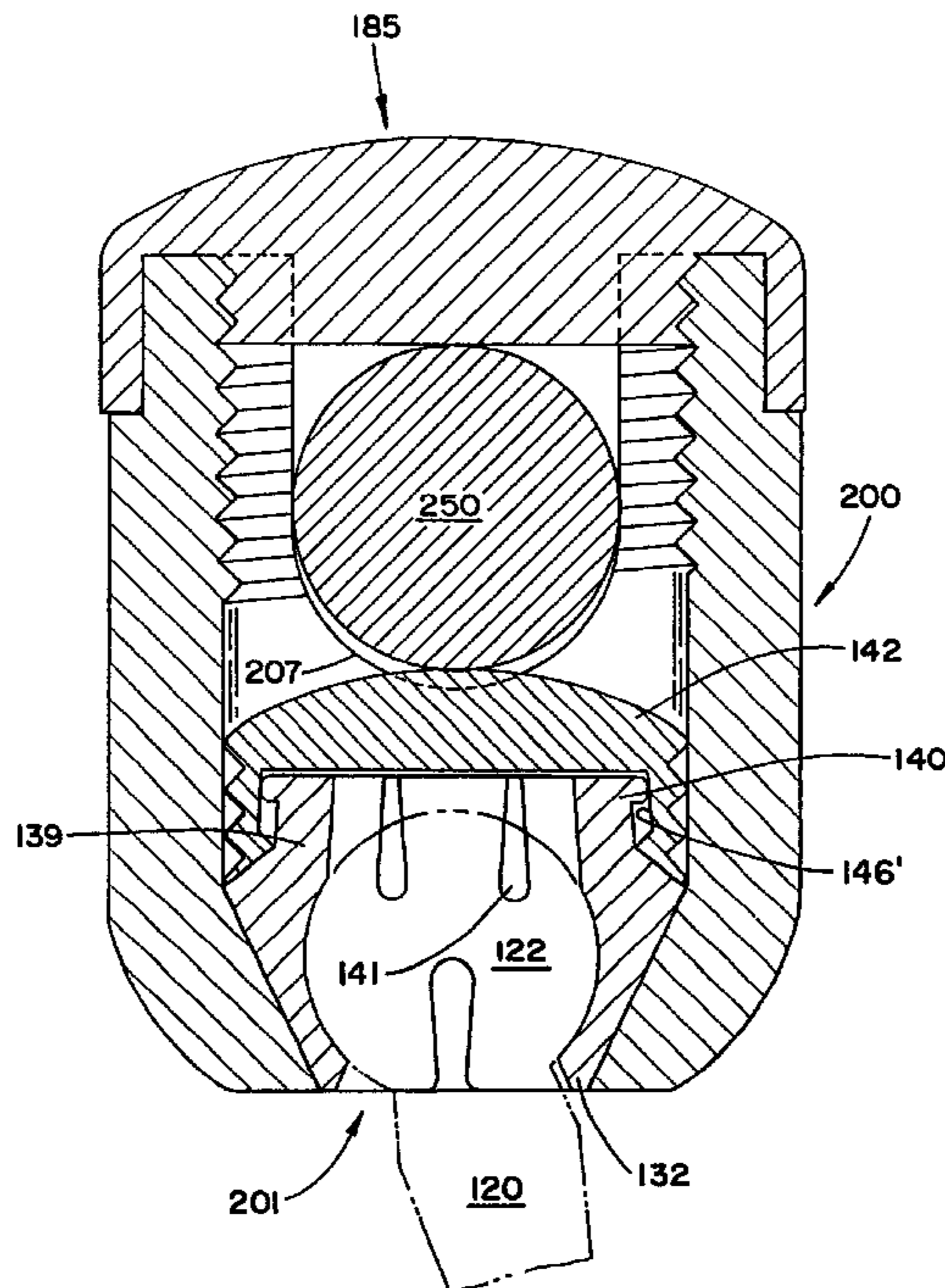

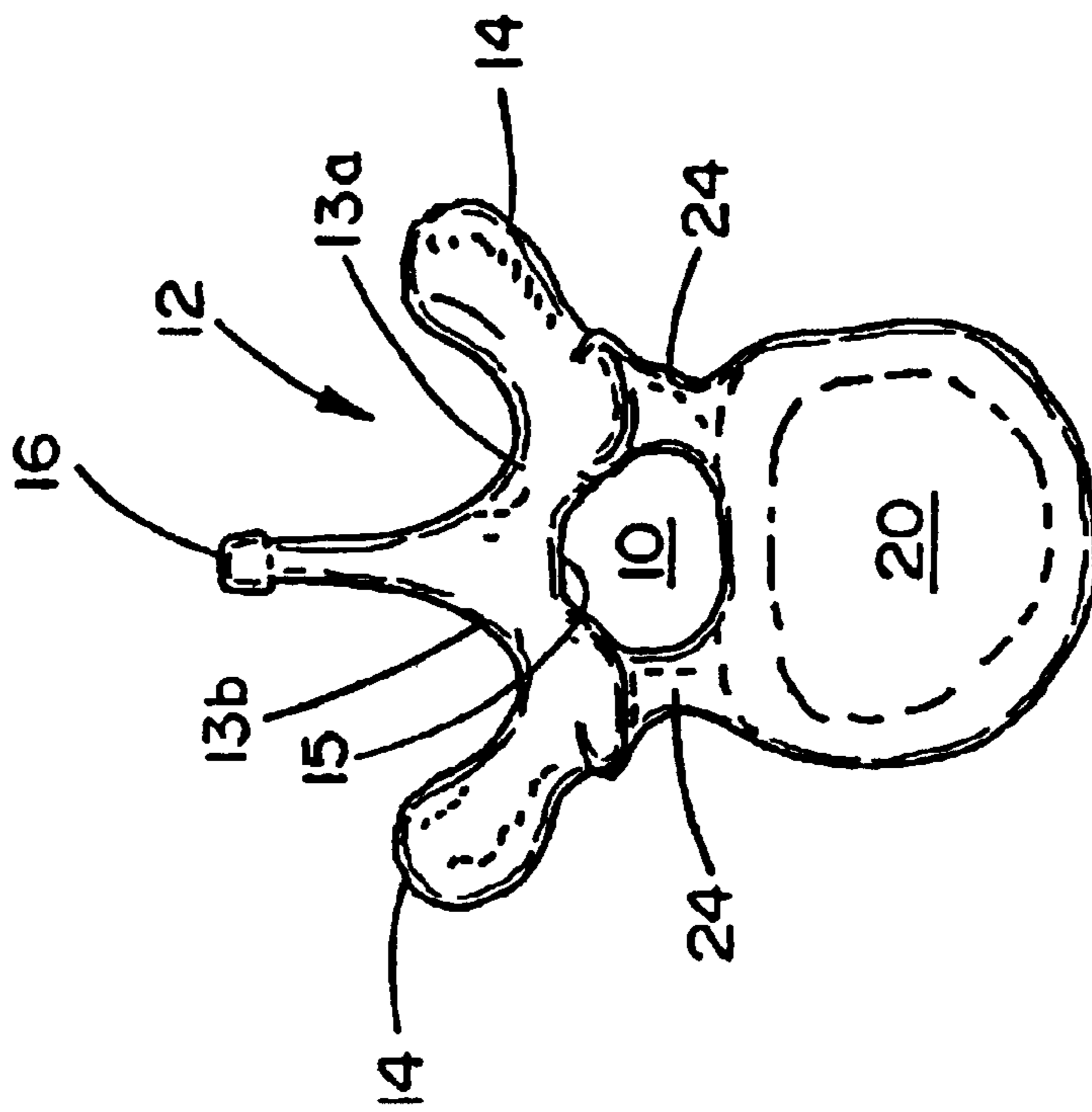

FIG. 1

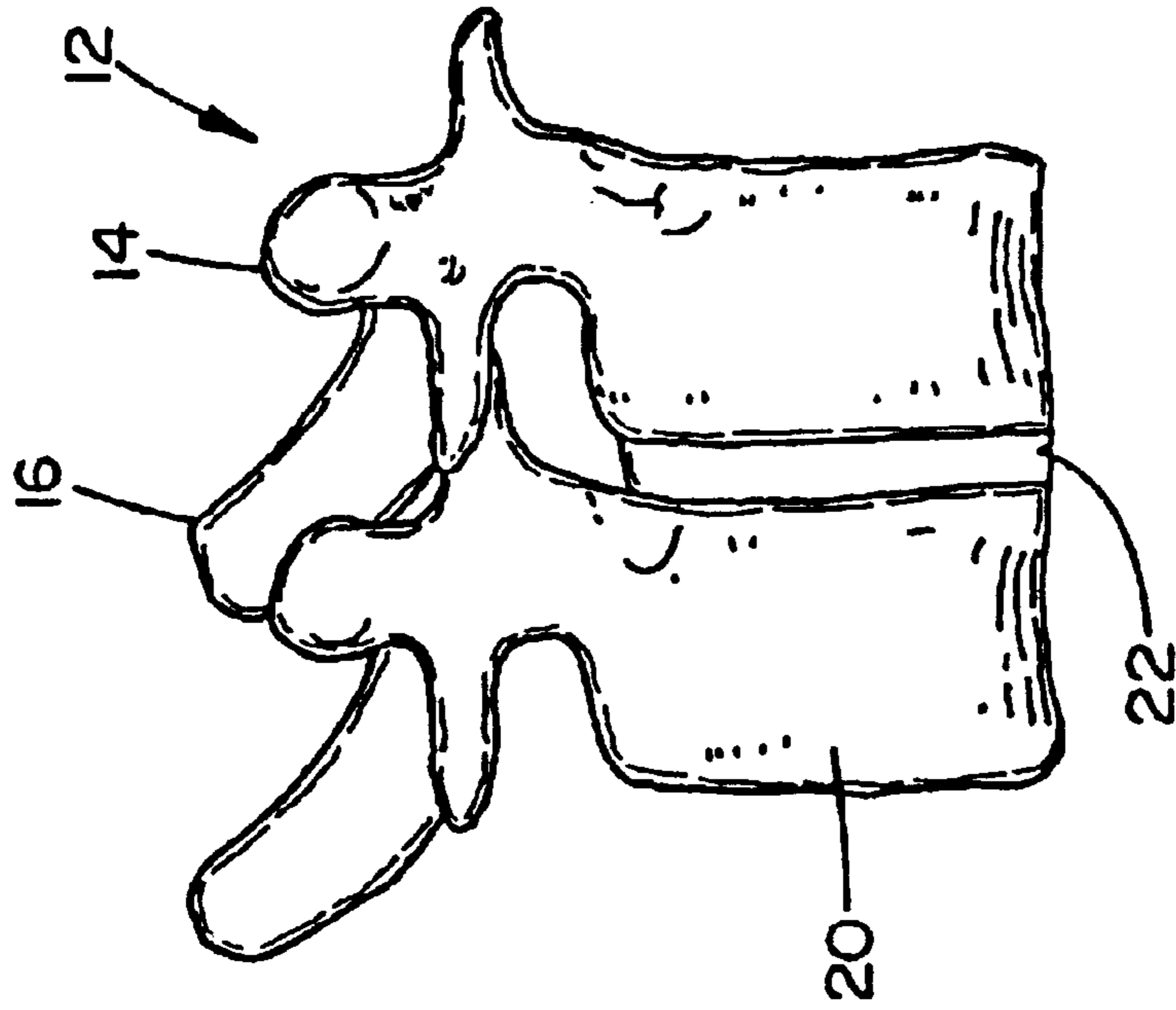

FIG. 2

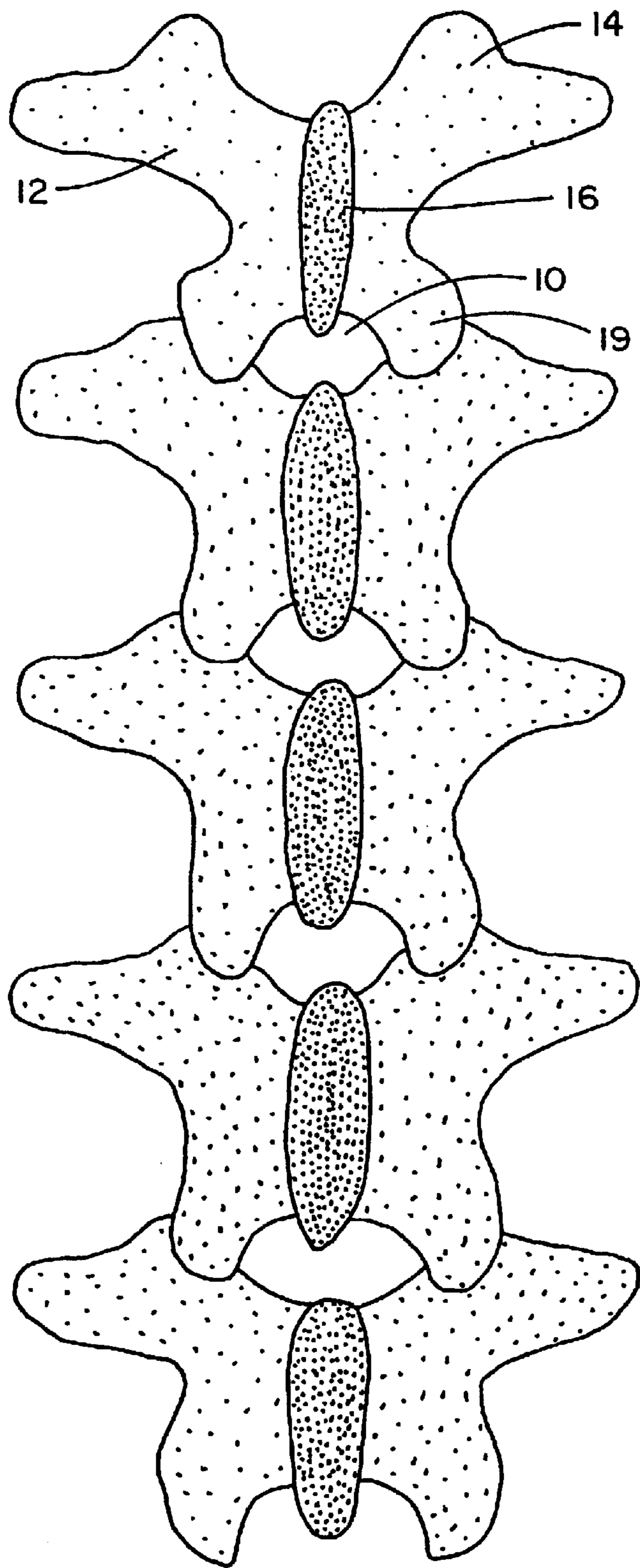

FIG. 3

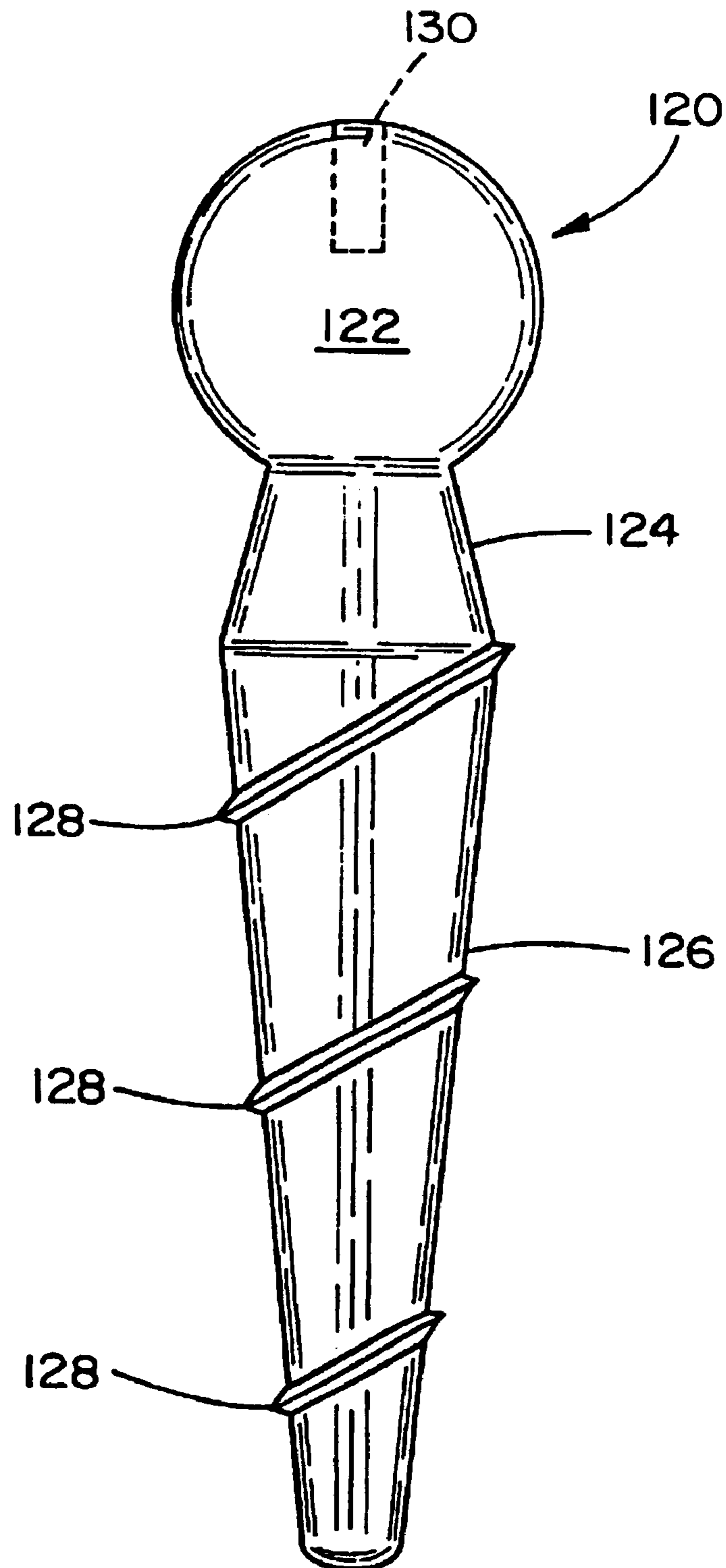
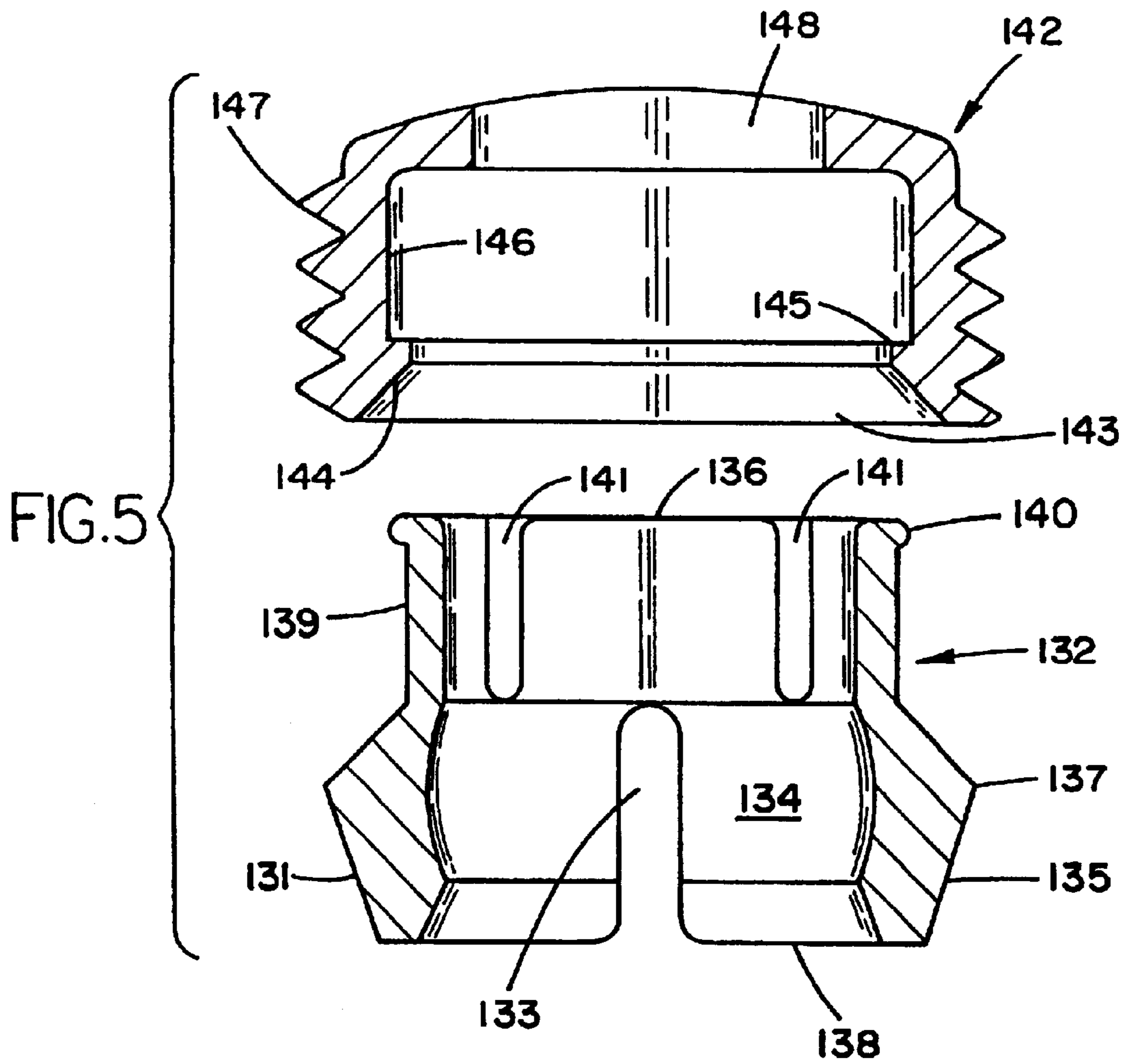

FIG. 4



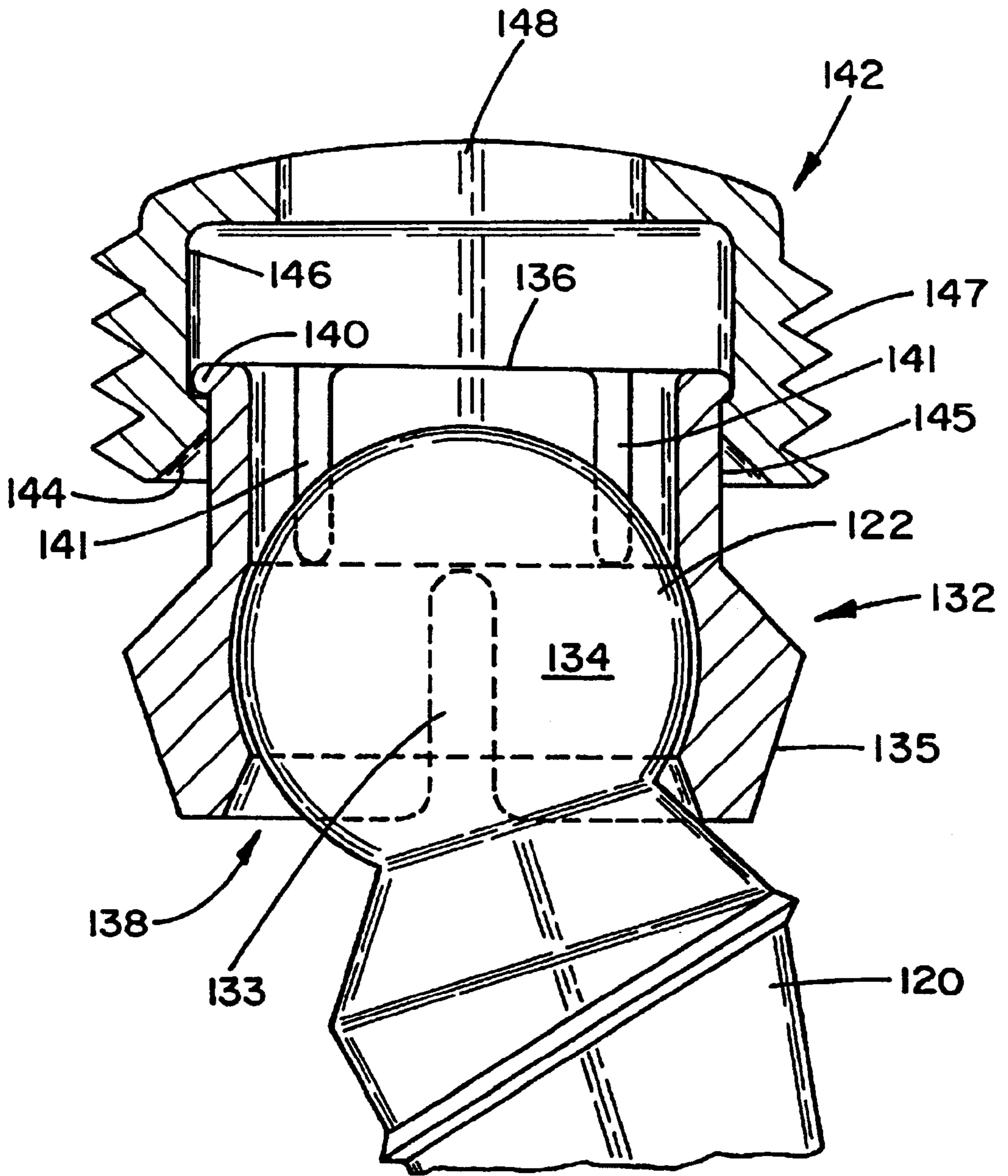

FIG. 6

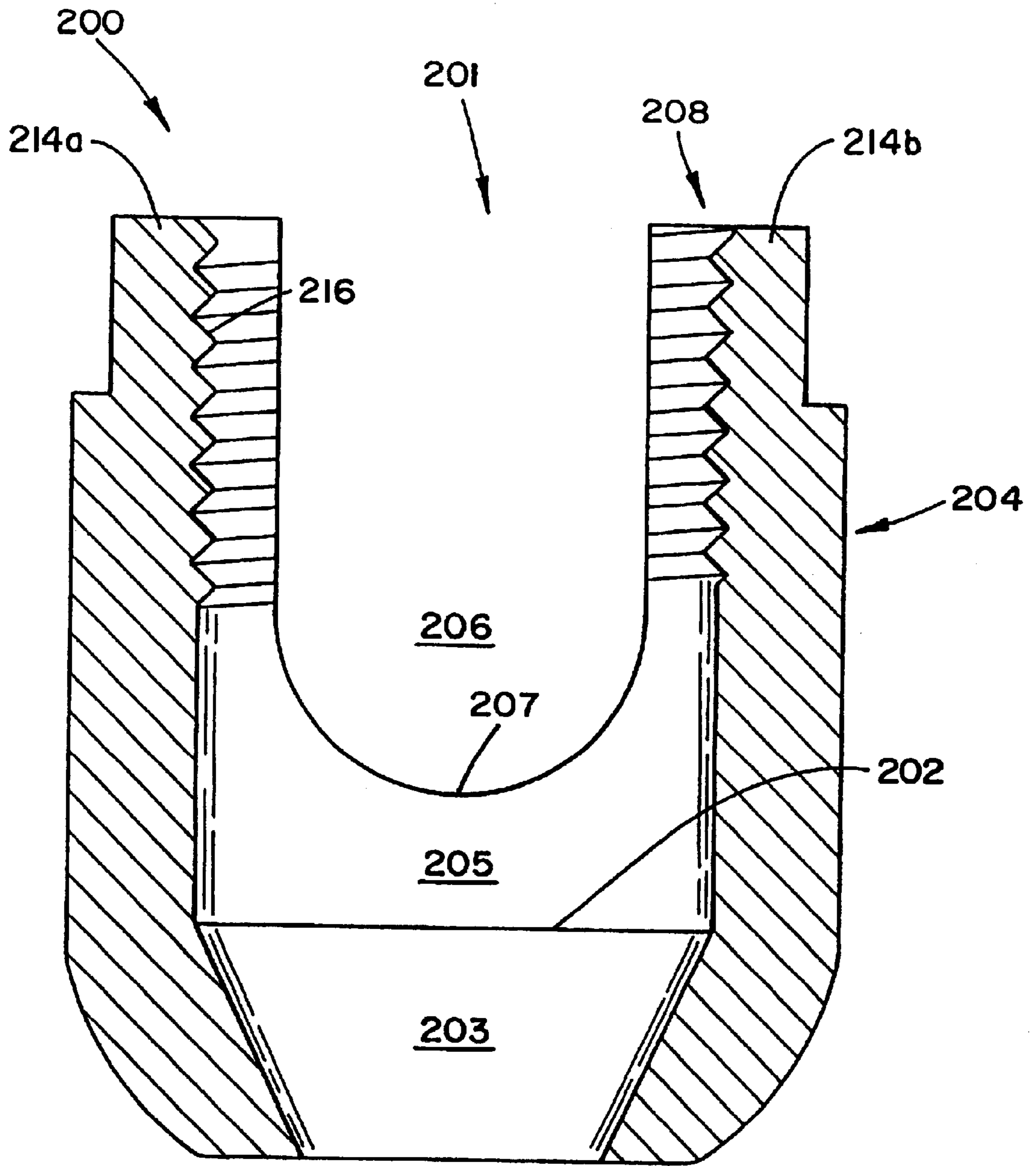

FIG. 7

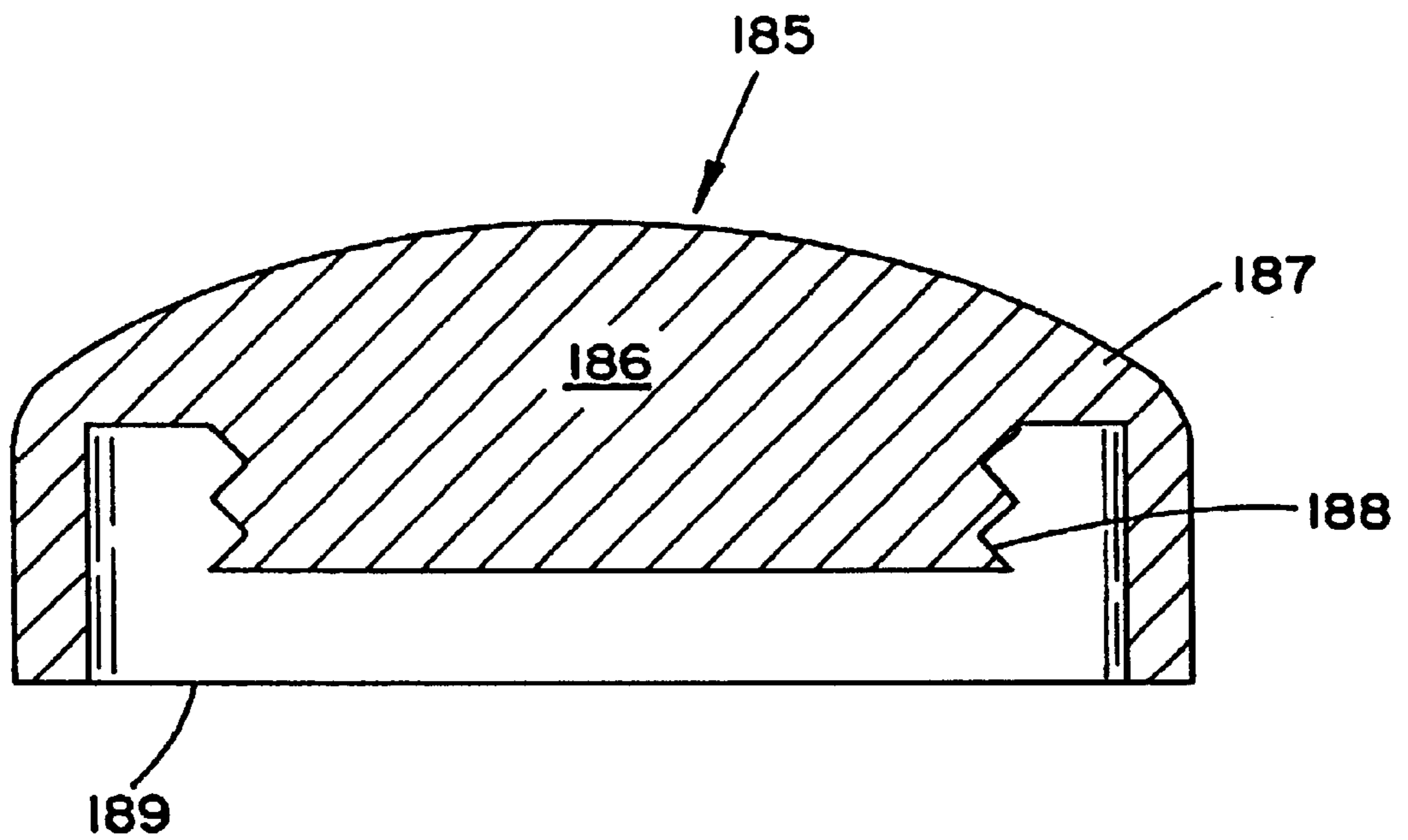

FIG. 8

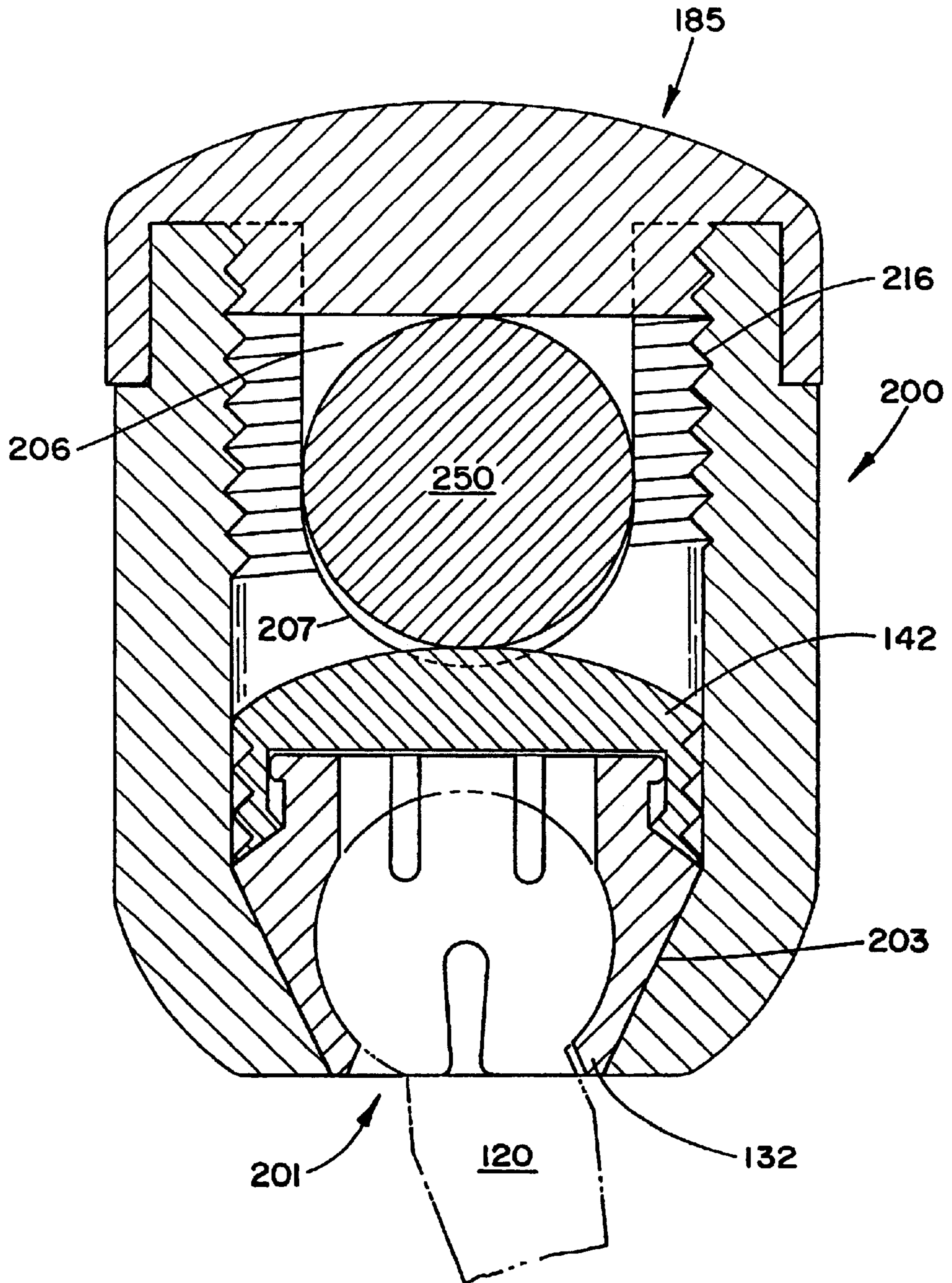

FIG. 9

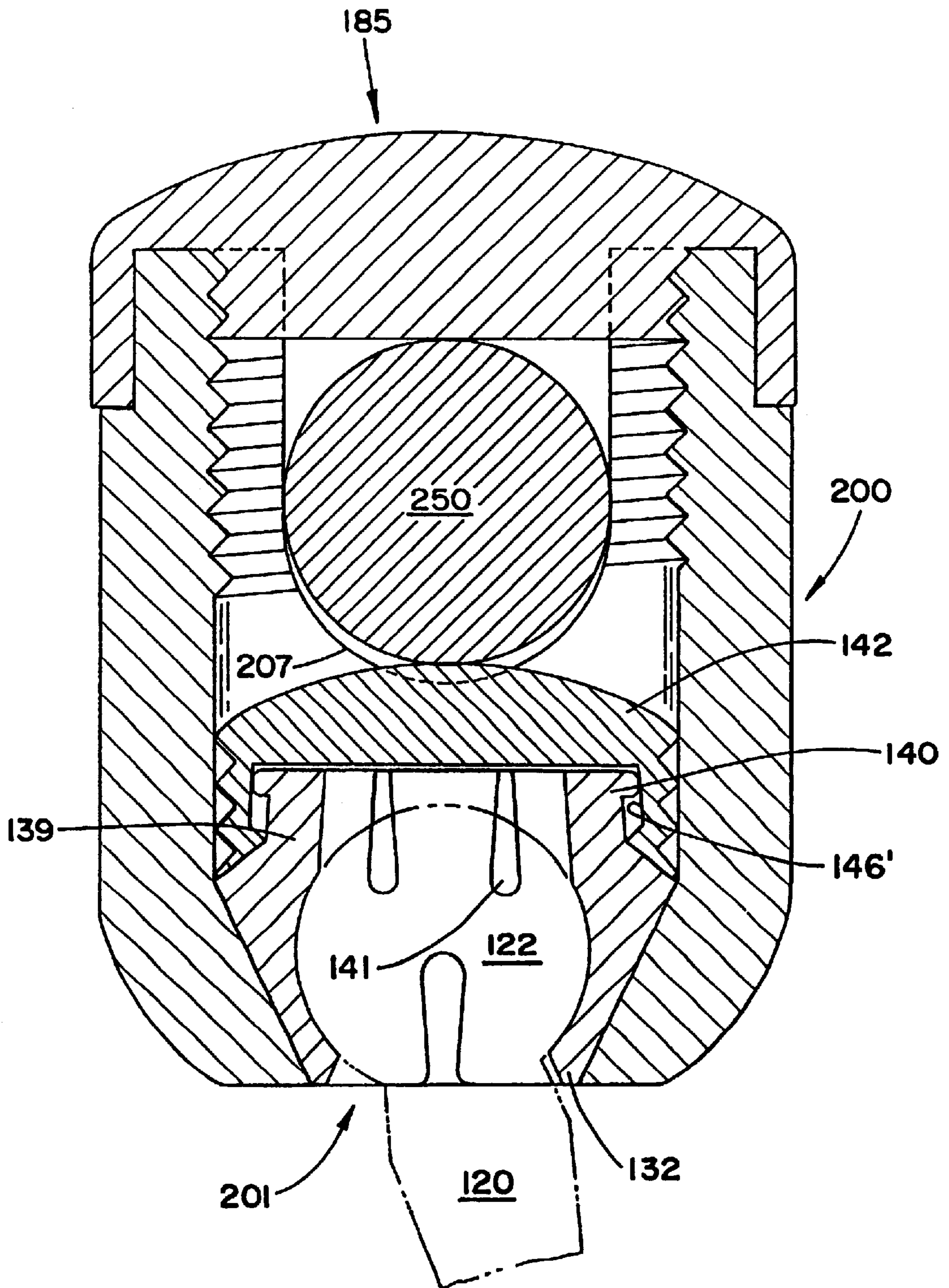

FIG. 10

**POLYAXIAL PEDICLE SCREW HAVING A
THREADED AND TAPERED COMPRESSION
LOCKING MECHANISM**

Matter enclosed in heavy brackets [] appears in the original patent but forms no part of this reissue specification; matter printed in italics indicates the additions made by reissue.

CROSS-REFERENCE TO PRIOR APPLICATION

This application is a continuation-in-part of prior application U.S. Ser. No. 08/663,383, entitled "A Polyaxial Pedicle Screw", filed Jun. 13, 1996, now U.S. Pat. No. 5,669,911 and which, in turn, was a continuation-in-part of Ser. No. 08/421,087, filed Apr. 13, 1995, now issued U.S. Pat. No. 5,520,690, entitled "An Anterior Spinal Polyaxial Locking Screw Plate Assembly".

BACKGROUND OF THE INVENTION

1. Field of the Invention

This invention relates generally to a polyaxial screw and coupling apparatus for use with orthopedic fixation systems. More particularly, the present invention relates to a screw for insertion into spinal bone, and a coupling element polyaxially mounted thereto, via a two-piece interlocking coupling element having a socket portion and a threaded compression member, for coupling the screw to an orthopedic implantation structure, such as a rod, therein enhancing the efficacy of the implant assembly by providing freedom of angulation among the rod, screw and coupling element.

2. Description of the Prior Art

The bones and connective tissue of an adult human spinal column consists of more than 20 discrete bones coupled sequentially to one another by a tri-joint complex which consist of an anterior disc and the two posterior facet joints, the anterior discs of adjacent bones being cushioned by cartilage spacers referred to as intervertebral discs. These more than 20 bones are anatomically categorized as being members of one of four classifications: cervical, thoracic, lumbar, or sacral. The cervical portion of the spine, which comprises the top of the spine, up to the base of the skull, includes the first 7 vertebrae. The intermediate 12 bones are the thoracic vertebrae, and connect to the lower spine comprising the 5 lumbar vertebrae. The base of the spine is the sacral bones (including the coccyx). The component bones of the cervical spine are generally smaller than those of the thoracic and lumbar spine. For the purposes of this disclosure, however, the word spine shall refer only to the cervical region.

Referring now to FIGS. 1, 2, and 3, top, side, and posterior views of a vertebral body, a pair of adjacent vertebral bodies, and a sequence of vertebral bodies are shown, respectively. The spinal cord is housed in the central canal 10, protected from the posterior side by a shell of bone called the lamina 12. The lamina 12 includes a rearwardly and downwardly extending portion called the spinous process 16, and laterally extending structures which are referred to as the transverse processes 14. The anterior portion of the spine comprises a set of generally cylindrically shaped bones which are stacked one on top of the other. These portions of the vertebrae are referred to as the vertebral bodies 20, and are each separated from the other by the intervertebral discs 22. The pedicles 24 comprise bone bridges which couple the anterior vertebral body 20 to the corresponding lamina 12.

The spinal column of bones is highly complex in that it includes over twenty bones coupled to one another, housing

and protecting critical elements of the nervous system having innumerable peripheral nerves and circulatory bodies in close proximity. In spite of these complexities, the spine is a highly flexible structure, capable of a high degree of curvature and twist in nearly every direction. Genetic or developmental irregularities, trauma, chronic stress, tumors, and disease, however, can result in spinal pathologies which either limit this range of motion, or which threaten the critical elements of the nervous system housed within the spinal column. A variety of systems have been disclosed in the art which achieve this immobilization by implanting artificial assemblies in or on the spinal column. These assemblies may be classified as anterior, posterior, or lateral implants. As the classifications suggest, lateral and anterior assemblies are coupled to the anterior portion of the spine, which is the sequence of vertebral bodies. Posterior implants generally comprise pairs of rods, which are aligned along the axis which the bones are to be disposed, and which are then attached to the spinal column by either hooks which couple to the lamina or attach to the transverse processes, or by screws which are inserted through the pedicles.

"Rod assemblies" generally comprise a plurality of such screws which are implanted through the posterior lateral surfaces of the laminae, through the pedicles, and into their respective vertebral bodies. The screws are provided with upper portions which comprise coupling elements, for receiving and securing an elongate rod therethrough. The rod extends along the axis of the spine, coupling to the plurality of screws via their coupling elements. The rigidity of the rod may be utilized to align the spine in conformance with a more desired shape.

It has been identified, however, that a considerable difficulty is associated with inserting screws along a misaligned curvature and simultaneously exactly positioning the coupling elements such that the rod receiving portions thereof are aligned so that the rod can be passed therethrough without distorting the screws. Attempts at achieving proper alignment with fixed screws is understood to require increased operating time, which is known to enhance many complications associated with surgery. Often surgical efforts with such fixed axes devices cannot be achieved, thereby rendering such instrumentation attempts entirely unsuccessful.

The art contains a variety of attempts at providing instrumentation which permit a limited freedom with respect to angulation of the screw and the coupling element. These teachings, however, are generally complex, inadequately reliable, and lack long-term durability. These considerable drawbacks associated with prior art systems also include difficulty properly positioned the rod and coupling elements, and the tedious manipulation of the many small parts in the operative environment.

It is, therefore, the principal object of the present invention to provide a pedicle screw and coupling element assembly which provides a polyaxial freedom of implantation angulation with respect to rod reception.

In addition, it is an object of the present invention to provide such an assembly which comprises a reduced number of elements, and which correspondingly provides for expeditious implantation.

Accordingly it is also an object of the present invention to provide an assembly which is reliable, durable, and provides long term fixation support.

Other objects of the present invention not explicitly stated will be set forth and will be more clearly understood in conjunction with the descriptions of the preferred embodiments disclosed hereafter.

SUMMARY OF THE INVENTION

The preceding objects of the invention are achieved by the present invention which is a polyaxial locking screw and coupling element for use with rod stabilization and immobilization systems in the spine. More particularly, the polyaxial screw and coupling element assembly of the present invention comprises a bone screw having a head which is curvate in shape, for example semi-spherical, and a two-piece interlocking coupling element mounted thereto. This combination is mounted inside the bottom of an internal channel of a cylindrical body member.

More specifically, with respect to the cylindrical body member, the tubular body comprises a rod receiving channel formed in the upper portion thereof, with a threading formed on the remaining upper elements so that a rod securing nut and/or set screw may be threaded thereon once a rod has been placed in the channel. The body further includes an axial bore which includes extends from the rod receiving channel through to the bottom of the cylinder. The portion of the axial bore which is below the channel forms a receiving chamber, the upper portion thereof having a constant diameter, and the lower portion of the chamber being inwardly tapered. The inner surface of the upper portion of the chamber and/or the inner surface of the portion of the axial bore which is above the chamber may further include a threading.

The two-piece interlocking coupling element comprises and socket portion and a cap portion. The socket portion is designed with an interior semi-spherical volume, so that it may receive the semi-spherical head of a corresponding bone screw. The interior volume of the socket portion is open at both axial ends thereof. The exterior surface of the socket portion, at the bottom thereof, includes a first set of slots which extend upwardly from the opening so that the interior semi-spherical volume may be expanded or contracted by the application of a radial force. In addition, the exterior surface at the bottom is tapered so that it is narrower at the bottom than at a midpoint. This taper is designed to mate with and nest in the tapered lower portion of the socket portion of the axial bore of the body member.

The upper exterior surface of the socket portion comprises a second set of slots, directed axially along the element to the midpoint, such that the upper opening of the socket element may expand and contract in accordance with the application of a radial force thereon. The exterior surface of this upper section of the socket portion is not tapered and is narrower than the widest taper position of the bottom of the socket portion. The upper section, however, does further include an outwardly extending annular lip at the uppermost axial position. This upper section is designed to be inserted into, and joined with, the cap portion of the coupling element.

The cap portion has a generally cylindrical shape, having an open bottom. The open bottom is inwardly tapered, forming an inwardly extending annular lip, so that as the upper end of the socket portion is inserted, its upper slots are narrowed. Once axially inserted beyond this taper, the upper section of the socket portion expands outward over the inwardly extending annular lip. The inwardly extending annular lip engages the outwardly extending lip of the socket portion so as to prevent disengagement of the two pieces. The socket portion is then permitted to slide into the cap portion, until the larger diameter of the tapered lower portion of the socket contacts the entrance of the cap portion.

The exterior surface of the cap portion may be threaded, so that it may engage a threading of the upper portion of the socket portion and/or the inner surface of the axial bore

which is above the socket portion. In addition, the top of the cap includes an opening so that a screw driving tool may directly engage the top of the screw.

The assembly of the entire device begins with the joining of the socket portion to the cap portion of the two-piece interlocking coupling element. This is achieved by the slideable interlocking mating of the two elements. Next, the semi-spherical head of the screw is inserted into the socket portion through the lower expandable opening in the taper portion. Once these parts have been assembled the screw and coupling element should be polyaxially rotateable relative to one another. The screw and coupling element are then inserted through the axial bore of the body (which may require the threading the cap portion of the coupling element along the threading on the inner surface of the axial bore and/or the threading of the cap along the threading of the upper portion of the chamber) until the socket portion nests in the tapered lower portion of the axial bore. If the upper portion of the chamber includes a threading it should not extend beyond the point of the initial nesting of the coupling element in the chamber. This is important because the cap portion must be able to move relative to the socket portion.

In this initial position, the top of the cap portion should rest above the bottom of the rod receiving channel so that a rod, when placed therein, seats directly onto the top of the cap. This direct contact provides the downward force necessary to compress the coupling element into the chamber so that the socket portion is compressed in the tapered portion and locks to the head of the screw.

In a preferred variation of this embodiment, the interior surface of the cap portion includes a slight narrowing taper so that as the cap is compressed downward by the rod, the upper slots of the socket portion are also narrowed, further increasing the crush locking effect on the head of the screw.

The implantation of this screw by a surgeon may proceed first by the assembly of the screw into its initial state. The shaft of the screw is then driven into the vertebral bone at the desired angulation. A rod is then introduced into the rod receiving channel, and the body is angulated into the most ideal position for receiving the rod. A nut and/or set screw is then used to secure the rod in the channel, and simultaneously to provide a sufficient downward translational force to cause the socket portion to be driven into the tapered portion of the chamber in the axial bore, and further to cause the cap portion to drive downwardly also (this further compression locking the screw head in the embodiment wherein the sliding of the cap portion toward the socket portion provides an additional compression on the top of the socket portion and therefore onto the head of the screw).

In a preferred variation, the locking nut comprises a cap nut which has a central post which is designed to provide additional structural support to the inner walls of the element at the top thereof, as well as providing a central seating pressure point for locking the rod in the channel. In either variation, the locking nut seats against the rod and prevents it from moving translationally, axially and rotationally.

Multiple screw assemblies are generally necessary to complete the full array of anchoring sites for the rod immobilization system, however, the screw assembly of the present invention is designed to be compatible with alternative rod systems so that, where necessary, the present invention may be employed to rectify the failures of other systems when the surgery may have already begun.

BRIEF DESCRIPTION OF THE FIGURES

FIG. 1 is a top view of a human vertebra, which is representative of the type for which the present invention is useful for coupling thereto a rod apparatus;

FIG. 2 is a side view of a pair of adjacent vertebrae of the type shown in FIG. 1;

FIG. 3 is a posterior view of a sequence of vertebrae of the type shown in FIGS. 1 and 2;

FIG. 4 is a side view of a screw having a curvate head which is an aspect of the present invention;

FIG. 5 is a side view of a two-piece interlocking coupling element of present invention;

FIG. 6 is a side view of a two-piece interlocking coupling element of present invention mounted around the head of a screw of the type shown in FIG. 4;

FIG. 7 is a side cross-sectional view of a cylindrical body having a chamber for receiving the two-piece interlocking coupling element and the screw of the present invention;

FIG. 8 is a side cross-sectional view of a top locking nut which is an aspect of the present invention;

FIG. 9 is a side cross-sectional view of an embodiment of the present invention in its fully assembled disposition having a rod securely locked therein;

FIG. 10 is a side view of an alternative embodiment of the present invention in its fully assembled disposition having a rod securely locked therein.

DETAILED DESCRIPTION OF THE PREFERRED EMBODIMENT

While the present invention will be described more fully hereinafter with reference to the accompanying drawings, in which particular embodiments and methods of implantation are shown, it is to be understood at the outset that persons skilled in the art may modify the invention herein described while achieving the functions and results of this invention. Accordingly, the descriptions which follow are to be understood as illustrative and exemplary of specific structures, aspects and features within the broad scope of the present invention and not as limiting of such broad scope.

Referring now to FIG. 4, a side view of the screw portion of the present invention, comprising a curvate head, is shown. The screw 120 comprises a head portion 122, a neck 124, and a shaft 126. In FIG. 4, the shaft 126 is shown as having a tapered shape with a high pitch thread 128. It shall be understood that a variety of shaft designs are interchangeable with the present design. The specific choice of shaft features, such as thread pitch, shaft diameter to thread diameter ratio, and overall shaft shape, should be made by the physician with respect to the conditions of the individual patient's bone, however, this invention is compatible with a wide variety of shaft designs.

The head portion 122 of the screw 120 comprises a semi-spherical shape, which has a recess 130 in it. It is understood that the semi-spherical shape is a section of a sphere, in the embodiment shown the section is greater in extent than a hemisphere, and it correspondingly exhibits an external contour which is equidistant from a center point of the head. In a preferred embodiment, the major cross-section of the semi-spherical head 122 (as shown in the two dimensional illustration of FIG. 4) includes at least 270 degrees of a circle.

The recess 130 defines a receiving locus for the application of a torque for driving the screw 120 into the bone. The specific shape of the recess 122 may be chosen to cooperate with any suitable screw-driving tool. For example, the recess 130 may comprise a slot for a screwdriver, a hexagonally shaped hole for receiving an allen wrench, or most preferably, a threading for a correspondingly threaded post. It is further preferable that the recess 130 be co-axial with

the general elongate axis of the screw 120, and most particularly with respect to the shaft 126. Having the axes of the recess 130 and the shaft 126 co-linear facilitates step of inserting the screw 120 into the bone.

The semi-spherical head portion 122 is connected to the shaft 126 at a neck portion 124. While it is preferable that the diameter of the shaft 126 be less than the diameter of the semi-spherical head 122, it is also preferable that the neck 124 of the screw 120 be narrower than the widest portion of the shaft 126. This preferable dimension permits the screw to swing through a variety of angles while still being securely joined to the locking collar (as set forth more fully with respect to FIGS. 5, 8-9).

Referring now to FIG. 5, the two elements which form the two-piece interlocking coupling element of the present invention are shown in a side cross-section view. Phantom lines show the interior structure of the elements along the diametrical cross section. With specific reference to the socket portion 132, the coupling element comprises a roughly cylindrical shape having an interior volume 134 in which the semi-spherical head 122 of the screw 120 is disposed. The interior volume 134 is open at the top 136 of the socket portion 132 and at the bottom thereof 138. The lower section 131 of the socket portion 132 comprises a set of slots 133 which extend vertically from the bottom 138 of the socket portion 132 to a position above the maximum diameter of the semi-spherical interior volume 134. These slots 133 permit the interior volume to expand and contract in accordance with the application of a radial force thereon. The external surface 135 of the lower section 131 of the socket portion 132 is tapered such that the narrowest part of the lower section 131 is at the bottom 138.

The upper section 139 of the socket portion 132 has a generally constant diameter, which is less than the diameter at the uppermost position 137 of the taper of the lower section 131. A second set of vertical slots 141 are provided in this upper section 139 so that it may also expand and contract in accordance with radial forces applied thereto. In addition, the uppermost end of this upper section 139 comprises an outwardly extending annular lip 140.

The cap portion 142 of the coupling element comprises an opening 143 in the bottom thereof, having an inwardly tapered entrance surface conformation 144. As the upper section 139 of the socket portion 132 is inserted into the opening 143 in the cap portion 142, the taper 144 of the opening 143 provides an inwardly directed force which causes the upper section 139 to contract (causes the slots 141 to narrow). This tapered entrance 144 opens to form an annular lip 145 which is useful for engaging and retaining the annular lip 140 of the upper section 139 of the socket portion 132. The interior surface 146 of the cap portion has a constant diameter, therein permitting the inserted upper section 139 of the socket portion 132 to slide and rotate relative to the cap portion 142.

The exterior surface of the cap portion 142 comprises a threading 147 which is designed to engage threadings 211 disposed in the axial bore of the rod receiving body member (see FIG. 7). In addition, the cap portion 142 comprises an axial hole 148 through which a surgeon may insert a screw driving tool to access the head of the screw which is positioned in the interior volume 134 of the socket portion 132.

More particularly, with respect to the disposition of the head 122 of the screw 120 in the socket portion 132, and with reference to FIG. 6, a partially assembled screw 120 and coupling element is shown in a side cross-section view.

The top **136** of the socket portion **132** is inserted into the opening in the cap portion **142** until the annular lip **140** of the socket **132** seats into the cap **142**. The screw **120** is loosely held within the socket **132**, which is, in turn, loosely retained within the cap **142**.

Referring now to FIG. 7, the rod receiving body member **200** of the present invention is shown in a side view, wherein critical features of the interior of the element are shown in phantom. The body member **200**, which comprises a generally cylindrical tubular body having an axial bore **201** extending therethrough, may be conceptually separated into a chamber portion **202** at the bottom of the axial bore **201**, and an upper rod receiving channel portion **204**, each of which shall be described more fully hereinbelow.

The upper rod receiving channel portion **204** of the body **200** includes a channel **206** formed therein, having rounded bottom surfaces **207**. The channel **206**, in turn, divides the walls of the cylindrical body of the upper portion **204** into a pair of upwardly extending members **214a**, **214b**. As shown in the embodiment illustrated in FIG. 7, the vertical distance from the top **208** of the channel to the curvate bottom **207** thereof, is larger than the diameter of the rod which is to be provided therein. This distance is necessarily larger than the diameter of the rod (see FIGS. 9 and 10) so that the rod may be fully nested in the channel **206**. In addition, the depth of the bottom curvate surface **207** of the channel is such that the cap portion **142** of the two-piece interlocking coupling element initially seats above the curvate bottom **207** of the body **200**.

The upwardly extending members **214a**, **214b** further have, disposed thereon, a threading **216** (which may be provided on the inner and/or outer circumferential surfaces, but which is shown in FIGS. 7, 9 and 10 as being on the inner circumferential surface). This threading **216** is ideally suited for receiving a top locking nut (see FIG. 8).

Referring now to the lower portion of the body, the chamber portion **202** can further be subdivided into a lower chamber portion **203** which includes an inwardly tapered surface, and an upper chamber portion **205** which has a constant diameter. The inwardly tapered portion **203** defines a nesting volume into which the socket portion **132** may nest. Prior to its being fully driven into this nesting volume, the socket portion **132** and the screw **120** disposed therein may be angulated relative to one another, and the screw **120** may be angulated relative to the body **200**. Once driven fully into the tapered lower chamber portion **203**, however, the taper of the axial bore **201** provides the necessary inwardly directed radial force to cause the socket portion **132** to crush lock to the head **122** of the screw **120**.

The force which causes the socket portion **132** to be driven downwardly into the tapered lower chamber portion **203** is provided by the cap portion **142**. More specifically, as stated above, when the initially assembled screw **120** and coupling element combination **132** and **142** (see FIG. 6) is advanced into the bottom of the axial bore **201** of the body **200**, and the socket portion **132** nests in the lower chamber portion **203**, the top of the cap portion **142** is positioned to receive the rod (see FIGS. 9 and 10) directly thereon. The locking of the rod in the channel **206** of the body **200** causes the cap portion **142** to be forced downwardly onto the socket portion **132**, which in turn drives the socket portion **132** into the tapered lower chamber portion **203** and causes it of compression lock to the head **122** of the screw **120**.

Referring now to FIG. 8, a top locking nut **185** is shown in side cross-section view. The nut **185** comprises post portion **186** and a flange portion **187**, each of which is

rotationally free, relative to the other. The post portion **186** includes a threading **188** thereon, for engaging and advancing along a threading **216** on the inner surface of the upwardly extending members **214a**, **214b** of the upper portion **204** of the body **200**. The bottom surface **189** of the flange portion **187** (which does not rotate relative to the body as the post portion **186** is rotationally advanced) is intended to seat against the top surface of the rod **250**.

Referring now to FIG. 9, in which the fully assembled and body member **200**, screw **120**, coupling element portions **132** and **142**, rod **250** and locking nut **185** are shown in side cross-section views, the implantation of this embodiment is described. First, the screw **120** and the two portions **132** and **142** of the coupling element are assembled into their initial association (see FIG. 6). The combination of the screw **120** and the two coupling element portions **132** and **142** are then advanced down the axial bore **201** of the body **200** until the socket portion **132** nests in the lower chamber **203** and the top of the cap portion **142** seats above the bottom **207** of the channel **206**. (This insertion of the subassembly of the screw **120** and coupling element portions **132** and **142** into the axial bore **201** of the body **200** may require the threaded advance of the cap portion **142** along the interior threads **216** of the body.)

The shaft of the screw **120** is then inserted and driven downward into the vertebral bone at the desired angle. Once properly positioned, the body **200** is rotated into the ideal rod receiving position. The rod **250** is then inserted into the channel **206** and the top locking nut **185** is threaded onto the threading **216** and compresses the rod **250** to securely lock it in the channel **206**. This downward force of the nut **185** and the rod **250** onto the cap portion **142** causes the cap portion to translate downward thus causing the socket portion **132** to translate downward in the tapered chamber **203** and contract to crush against the head **122** of the screw **120**. The assembly is thereby fully locked in position.

Referring to FIG. 10, a variation of the above device is shown in a similar cross-section view. In this embodiment, the inner surface **146'** of the cap portion **142** is tapered inwardly in the vertical direction so that the downward translation of the cap portion **142** causes the annular lip **140** of the socket portion **132** to be compressed inwardly. This causes the slots **141** of the upper section **139** of the socket portion **132** to narrow. This may be utilized to further clamp the interior volume **134** against the head **122** of the screw **120**.

While there has been described and illustrated embodiments of a polyaxial screw and coupling element assembly for use with posterior spinal rod implantation apparatus, it will be apparent to those skilled in the art that variations and modifications are possible without deviating from the broad spirit and principle of the present invention. The present invention shall, therefore, be limited solely by the scope of the claims appended hereto.

We claim:

1. A polyaxial screw and coupling element assembly for use with orthopedic rod implantation apparatus, comprising:
 - a screw having a semi-spherical head;
 - a cylindrical body including an axial bore defining a bottom chamber portion at a bottom end thereof and a rod receiving channel at a top end thereof, said bottom chamber portion further defining a tapered lower portion and a constant diameter upper chamber portion, and said top end having a threading thereon;
 - a two-piece interlocking coupling element including
 - a socket portion having a semi-spherical interior volume for receiving therein the head of said screw,

upper and lower sections, and vertical slots formed in said upper and lower sections, at least one of said slots rendering said interior volume expandable and contractable, said lower section having a tapered exterior surface for nesting in said tapered lower chamber portion of said cylindrical body such that forceable advancement of socket portion along the tapered lower chamber portion of the axial bore causes the at least one of said slots to narrow such that the semi-spherical interior volume contract, and a cap portion having an opening in a bottom thereof and an interior chamber extending upwardly therefrom for joining with, and slideably retaining therein, the upper section of said socket portion, said cap portion initially seating with a portion thereof extending into a bottom portion of said rod receiving channel; and a top locking nut, mateable with said threading, for locking a rod in said channel and for applying there-through a downward force onto said cap portion, wherein said semi-spherical head portion is rotationally freely mounted within the semi-spherical interior volume of the socket portion prior to said socket portion being forceably advanced into the tapered lower chamber portion of the axial bore, and whereby downward compression of a rod in said channel portion of said body member, by said top locking nut, onto the cap portion causes the forceable advancement of the socket portion into the tapered lower chamber portion of the axial bore, and locks the screw, coupling element and body relative to one another.

2. The polyaxial screw as set forth in claim 1, wherein said semi-spherical head of said screw further includes a recess formed therein for receiving therein a screwdriving tool such that said screw may be threadably advanced into a vertebral bone.

3. The polyaxial screw as set forth in claim 1, wherein said threading on said top end is on the interior surface of said channel.

4. The polyaxial screw as set forth in claim 3, wherein said cap portion further includes a threading and wherein said cap portion needs to be threadably advanced along the threading to be seated in the bore into its initial position.

5. The assembly as set forth in claim 1,

wherein said socket portion further comprises a substantially constant diameter upper section having an outwardly annular extending lip at an extreme end thereof, wherein said opening in the bottom of the cap portion comprises an inwardly directed annular lip, and wherein at least one of said vertical slots in the upper section of said socket portion renders the upper section thereof to be expandable and contractable such that the upper section of the socket portion may be forceably inserted into the opening in the bottom of the cap portion so that it may be retained in the interior chamber therein by mutual interference engagement of the inwardly directed annular lip of the cap portion and the outwardly extending annular lip of the socket portion.

6. The assembly as set forth in claim 5, wherein the interior chamber of the cap portion comprises a tapered surface such that advancement thereof into the hole causes an inwardly directed force against the upper section of the socket portion, therein causing the at least one of said vertical slots in the upper section to narrow and causes the upper section to contract and further lock the head of the screw within the interior semi-spherical volume of the socket portion.

7. An orthopaedic implant apparatus having a rod and a plurality of screw and coupling element assemblies, comprising:

at least one screw having a semi-spherical head;

at least one cylindrical body including an axial bore defining a bottom chamber portion at a bottom end thereof and a rod receiving channel at a top end thereof, said bottom chamber portion further defining a tapered lower portion and a constant diameter upper chamber portion, and said top end having a threading thereon;

at least one corresponding two-piece interlocking coupling element including

a socket portion having a semi-spherical interior volume for receiving therein the head of said corresponding screw, upper and lower sections, and vertical slots formed in said upper and lower sections, at least one of said slots rendering said interior volume expandable and contractable, said lower section having a tapered exterior surface for nesting in said corresponding tapered lower chamber portion of said cylindrical body such that forceable advancement of socket portion along the tapered lower chamber portion of the axial bore causes the at least one of said slots to narrow such that the semi-spherical interior volume contract, and

a cap portion having an opening in a bottom thereof and an interior chamber extending upwardly therefrom for joining with, and slideably retaining therein, the upper section of said socket portion, said cap portion initially seating with a portion thereof extending into a bottom portion of said rod receiving channel; and

at least one corresponding top locking nut, mateable with said threading, for locking a rod in said channel and for applying therethrough a downward force onto said cap portion,

wherein said semi-spherical head portion is rotationally freely mounted within the semi-spherical interior volume of the socket portion prior to said socket portion being forceably advanced into the tapered lower chamber portion of the axial bore, and

whereby downward compression of a rod in said channel portion of said body member, by said top locking nut, onto the cap portion causes the forceable advancement of the socket portion into the tapered lower chamber portion of the axial bore, and locks the screw, coupling element and body relative to one another.

8. The apparatus as set forth in claim 7, wherein said threading on said top end is on the interior surface of said channel.

9. The apparatus as set forth in claim 8, wherein said cap portion further includes a threading and wherein said cap portion needs to be threadably advanced along the threading to be seated in the bore into its initial position.

10. The apparatus as set forth in claim 7,

wherein said socket portion further comprises a substantially constant diameter upper section having an outwardly annular extending lip at an extreme end thereof, wherein said opening in the bottom of the cap portion comprises an inwardly directed annular lip, and

wherein at least one of said vertical slots in the upper section of said socket portion renders the upper section thereof to be expandable and contractable such that the upper section of the socket portion may be forceably inserted into the opening in the bottom of the cap portion so that it may be retained in the interior chamber therein by mutual interference engagement of

the inwardly directed annular lip of the cap portion and the outwardly extending annular lip of the socket portion.

11. The apparatus as set forth in claim 10, wherein the interior chamber of the cap portion comprises a tapered surface such that advancement thereof into the hole causes an inwardly directed force against the upper section of the socket portion, therein causing the at least one of said vertical slots in the upper section to narrow and causes the upper section to contract and further lock the head of the screw within the interior semi-spherical volume of the socket portion.

12. An orthopedic fixation assembly for securing an orthopedic rod implantation apparatus, comprising:

a cylindrical body including an axial bore extending therethrough, said body including a channel at a top end of said body, said axial bore defining a chamber portion at a bottom end of said body, said chamber portion having an upper chamber portion and a bottom chamber portion, said bottom chamber portion further including a retaining surface, and said top end of said body having a threading thereon;

a screw having a semi-spherical head, said semi-spherical head is mounted within said bottom chamber portion of said axial bore of said body;

a coupling assembly comprising:

a retaining portion having an inner surface for seating said semi-spherical head of said screw, said retaining portion further including a slot formed therein, said slot rendering a volume of said retaining portion to be adjustable, said retaining portion further being shaped to seat in said retaining surface of said bottom chamber of said axial bore of said cylindrical body, such that advancement of semi-spherical head against said retaining portion causes said head of said screw to be compression locked thereagainst, a cap portion slidably located within said upper chamber portion and adapted for location between a rod and said top surface of said screw head; and

a top locking nut, mateable with said threading of said body,

wherein said semi-spherical head portion is freely rotational within said retaining portion prior to being compressed onto said retaining portion, and

whereby when the rod is in said channel, downward movement of said top locking nut onto the rod results in a force upon said cap portion causing forcible advancement of the semi-spherical head of said screw thereby locking said screw, said coupling assembly and said body relative to one another.

13. The orthopedic fixation assembly set forth in claim 12, wherein said axial bore has a substantially constant diameter at said upper chamber portion.

14. The orthopedic fixation assembly set forth in claim 12, wherein said semi-spherical head of said screw further includes a recess for receiving a screwdriving tool such that said screw may be threadably advanced into a vertebral bone.

15. The orthopedic fixation assembly set forth in claim 12, wherein said threading on said top end is on a surface of said axial bore.

16. The orthopedic fixation assembly set forth in claim 15, wherein said cap portion further includes a threading mating with said threading on said axial bore and wherein said cap portion is threadably advanced along said threading of said axial bore to be seated into said upper chamber portion.

17. The orthopedic fixation assembly set forth in claim 12 wherein said channel extends through a top surface of said body creating at least one pair of upwardly extending members.

18. An orthopedic fixation assembly for use with an orthopedic rod implantation apparatus, comprising:

a body comprising an axial bore extending therethrough and a channel extending perpendicularly to said axial bore at a top end of said body, said axial bore having a threaded portion at said top end of said body member and a chamber portion at a bottom end of said body member, said chamber portion defining an upper chamber portion and a bottom chamber portion, said bottom chamber portion including a nesting surface defining a nesting volume;

a screw having a semi-spherical head, said semi-spherical head being located within said chamber portion of said body member;

a coupling element comprising:

a retaining portion having an inner surface which seats said semi-spherical head of said screw permitting angulation of said screw relative to said body, and an outer surface being seated within said nesting volume, said retaining portion further including a slot extending between said inner and outer surfaces, said slot rendering at least said outer surface of retaining portion to be deformable; and

a cap portion moveably located within said upper chamber portion and over said semi-spherical head of said screw; and

a locking nut having a threaded portion which is mateable with said threaded portion of said axial bore allowing a portion of said locking nut to advance into said axial bore;

wherein when a rod is placed in said channel, advancement of said locking nut produces a downward force on the rod translating into a downward movement of at least said cap portion and said screw causing deformation of said outer surface of said retaining portion within said nesting surface resulting in a locking force applied by said retaining portion against said semi-spherical head causing said screw to be compression locked within said body.

19. The orthopedic fixation assembly of claim 18, where said semi-spherical head of said screw further comprises a recess formed therein for receiving a screwdriving tool such that said screw may be threadably advanced into a vertebral bone.

20. The orthopedic fixation assembly of claim 18, wherein said axial bore has a constant diameter at said upper chamber portion.

21. The orthopedic fixation assembly of claim 18, wherein said cap portion further includes a threading and wherein said cap portion is threadably advanced along said threaded portion of said axial bore prior to seating in said chamber portion.

22. The orthopedic fixation assembly of claim 18, wherein said locking nut includes a post position which is seated in said axial bore, wherein when the rod is in said channel, a bottom surface of said post portion contacts the rod.

23. The orthopedic fixation assembly set forth in claim 18 wherein said channel extends through a top surface of said body creating at least one pair of upwardly extending members.

UNITED STATES PATENT AND TRADEMARK OFFICE
CERTIFICATE OF CORRECTION

PATENT NO. : RE 37,665 E
DATED : April 16, 2002
INVENTOR(S) : James D. Ralph and Stephen Tatar

Page 1 of 1

It is certified that error appears in the above-identified patent and that said Letters Patent is hereby corrected as shown below:

Column 12,

Line 59, please replace "position" with -- portion --.

Signed and Sealed this

Fourth Day of June, 2002

Attest:

A handwritten signature in black ink, appearing to read "James E. Rogan", written over a horizontal line.

Attesting Officer

JAMES E. ROGAN
Director of the United States Patent and Trademark Office

UNITED STATES PATENT AND TRADEMARK OFFICE
CERTIFICATE OF CORRECTION

PATENT NO. : RE 37,665 E
DATED : April 16, 2002
INVENTOR(S) : Ralph et al.

Page 1 of 1

It is certified that error appears in the above-identified patent and that said Letters Patent is hereby corrected as shown below:

Column 1,

Line 1, insert -- Notice: More than one reissue application has been filed for the reissue of patent 5,882,350. The reissue applications are application numbers 09/774,915 (the present application), and 09/992,612, which is a continuation of U.S. Patent RE37,665. --

Signed and Sealed this

Fourteenth Day of June, 2005

A handwritten signature in black ink on a light gray dotted background. The signature reads "Jon W. Dudas" in a cursive style.

JON W. DUDAS

Director of the United States Patent and Trademark Office