



US00RE37559E

(19) **United States**  
(12) **Reissued Patent**  
Marue et al.

(10) **Patent Number: US RE37,559 E**  
(45) **Date of Reissued Patent: Feb. 26, 2002**

(54) **TELESCOPING MAST WITH INTEGRAL PAYLOAD**  
  
(76) Inventors: **Edward A. Marue**, 7570 Calle Sin Controversia, Tucson, AZ (US) 85718; **Kenneth J. Pereira**, 8178 E. Grangeville, Hanford, CA (US) 93230

797,464 A	8/1905	Sjastram	182/232
1,426,276 A	8/1922	Christie	52/118
2,499,137 A	2/1950	Friedberg et al.	250/33
2,861,268 A	11/1958	Tinsley	343/902
3,158,865 A	11/1964	McCorkle	343/709
3,347,003 A	10/1967	Lapp	52/169
3,373,285 A	3/1968	Barrett	250/91
3,688,455 A	9/1972	Zebuhr	52/115
4,062,156 A	12/1977	Roth	52/111
4,180,850 A	12/1979	Bivens	362/285
4,254,423 A	3/1981	Reinhard	52/118
4,577,827 A	3/1986	Eliscu	248/656
4,663,900 A	5/1987	Rehm et al.	52/118 X
4,725,846 A	2/1988	Hendershot	343/792
4,871,138 A	10/1989	Sauter	248/408
4,932,176 A	6/1990	Roberts et al.	52/118
5,101,215 A	3/1992	Creaser, Jr.	343/883
5,117,595 A	6/1992	Brendel	52/115
5,163,650 A	11/1992	Adams et al.	248/405
5,168,679 A	12/1992	Featherstone	52/118
5,218,375 A	6/1993	Hillman	52/118

(21) Appl. No.: **09/283,843**  
(22) Filed: **Mar. 31, 1999**

**Related U.S. Patent Documents**

Reissue of:  
(64) Patent No.: **5,615,855**  
Issued: **Apr. 1, 1997**  
Appl. No.: **08/353,118**  
Filed: **Dec. 9, 1994**

**U.S. Applications:**

(63) Continuation-in-part of application No. 08/072,817, filed as application No. PCT/US92/08721 on Oct. 6, 1992, now Pat. No. 5,593,129, which is a continuation-in-part of application No. 07/772,167, filed on Oct. 7, 1991, now Pat. No. 5,163,650.  
(51) **Int. Cl.<sup>7</sup>** ..... **F16M 11/00**  
(52) **U.S. Cl.** ..... **248/405; 52/40; 52/117; 52/118; 82/141; 248/188.5; 248/333; 248/406.1; 343/713; 343/883; 343/901**  
(58) **Field of Search** ..... 248/405, 454.3, 248/454.4, 651, 406.1, 411, 422, 188.5, 334.1, 333, 335; 343/883, 878, 880, 901, 713; 52/67, 105, 118, 117, 40; 82/141

**FOREIGN PATENT DOCUMENTS**

CA	671611	10/1963	248/405
DE	1260800	2/1968	248/405
DE	3434517	3/1986	52/118
DE	3611810	8/1986	52/118
DE	3636893	7/1987	52/118
FR	1430168	1/1966	
FR	2 555 820	5/1985	52/118
FR	2 575 780	7/1986	52/118
GB	124268	3/1919	

*Primary Examiner*—Ramon O. Ramirez  
(74) *Attorney, Agent, or Firm*—Drummond & Duckworth

(57) **ABSTRACT**

In an integrated telescoping mast-payload assembly, the payload forms the top telescoping section.

(56) **References Cited**

**U.S. PATENT DOCUMENTS**

388,491 A 8/1888 Hill ..... 182/232

**17 Claims, 5 Drawing Sheets**

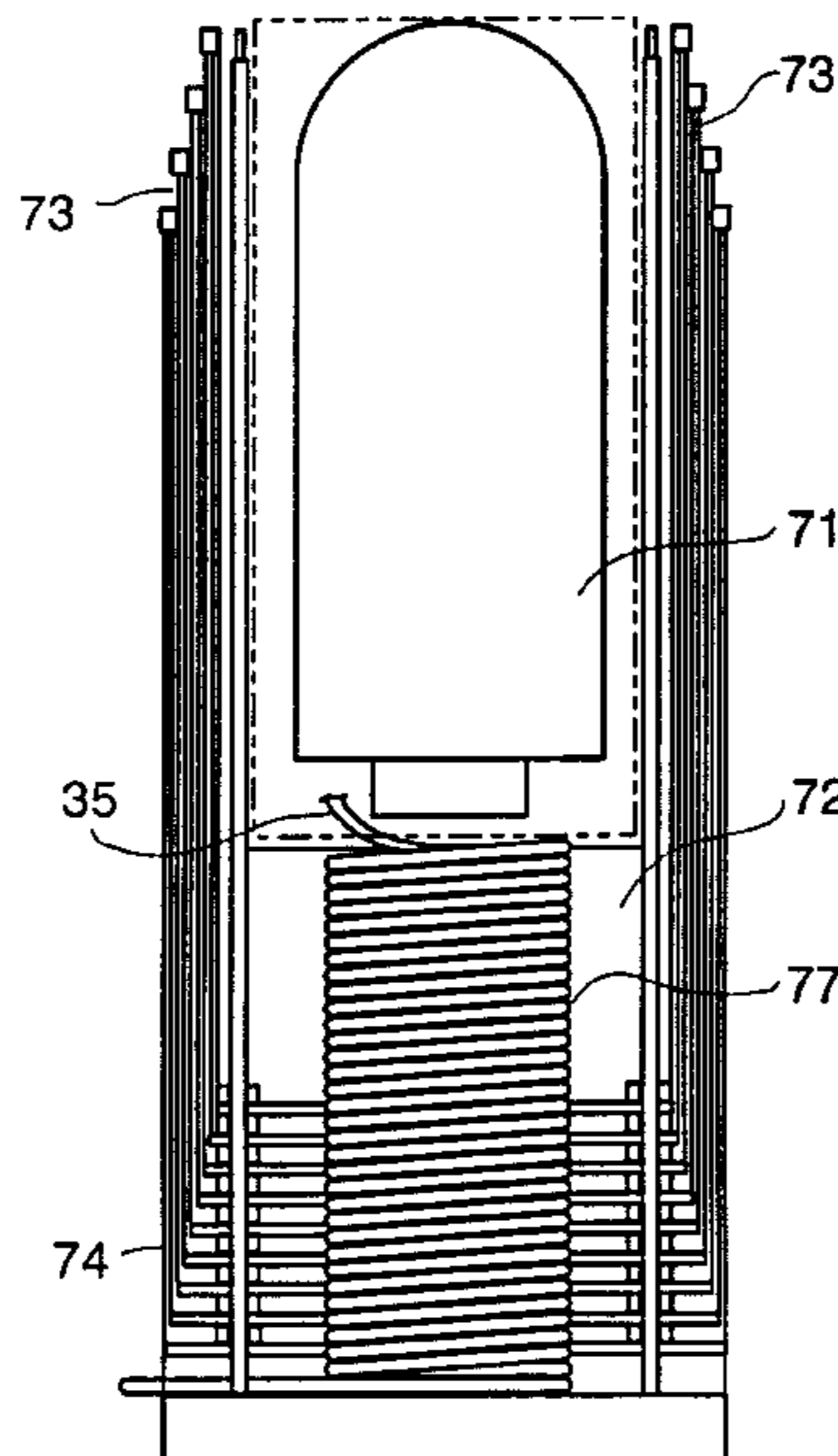

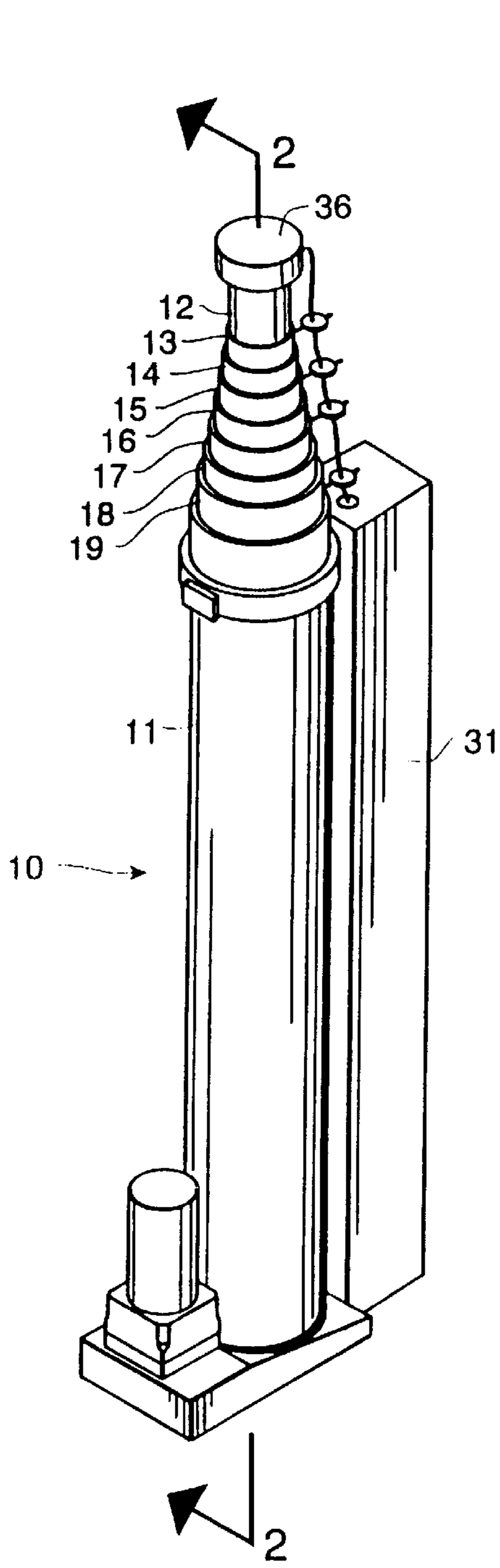

FIG. 1

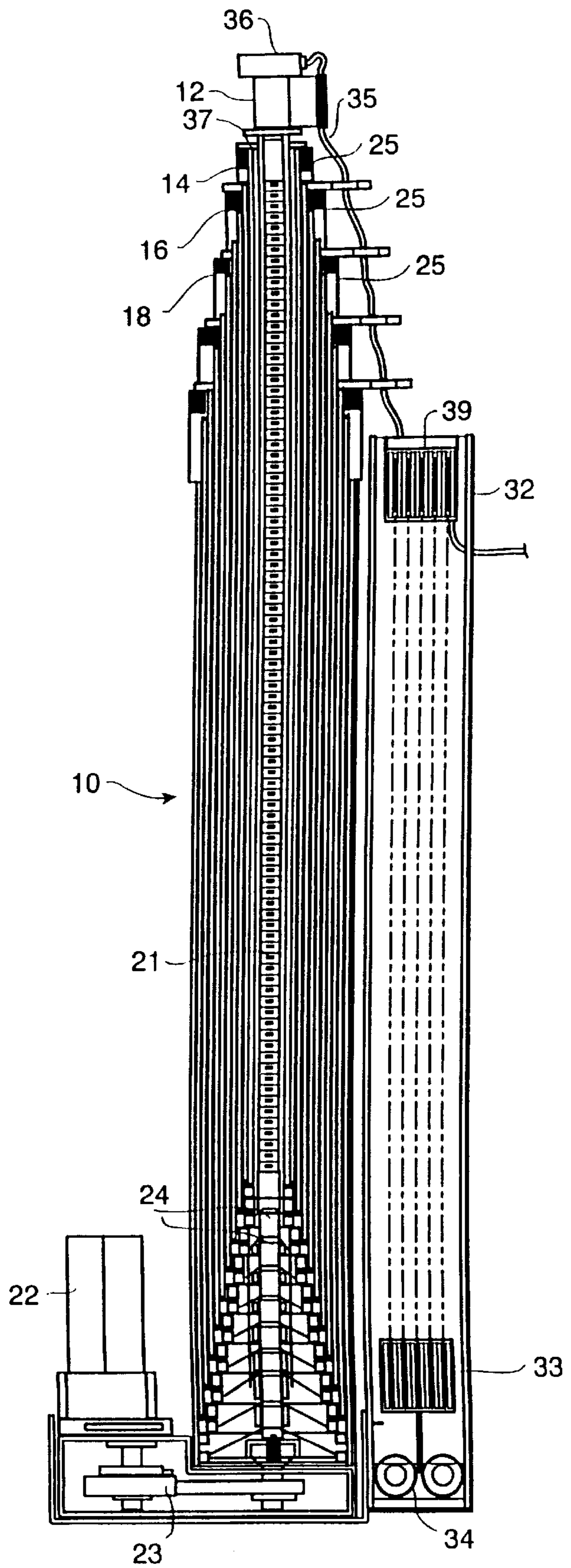

FIG. 2

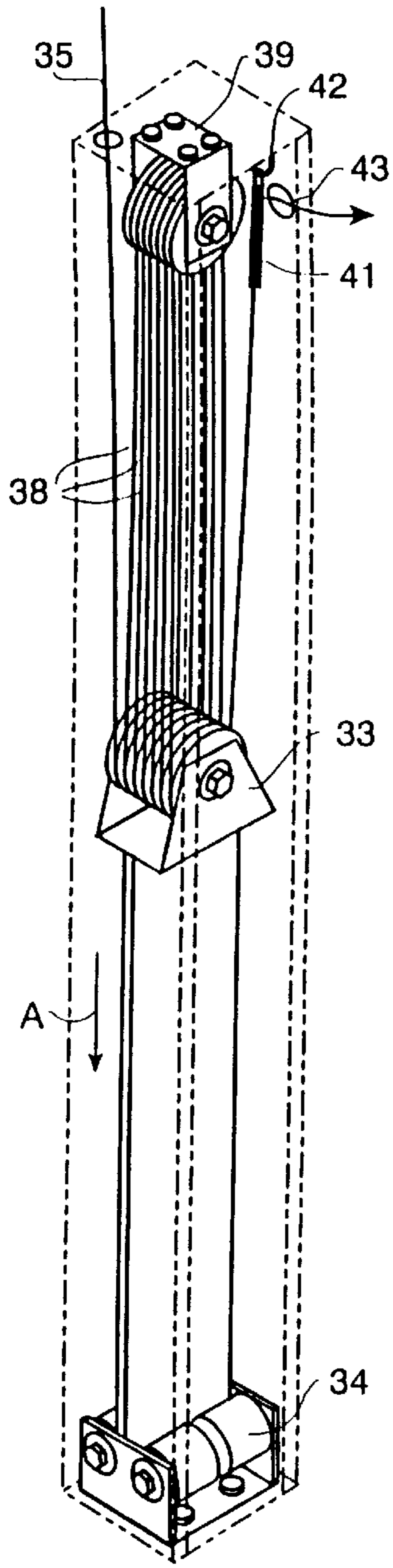

FIG. 3

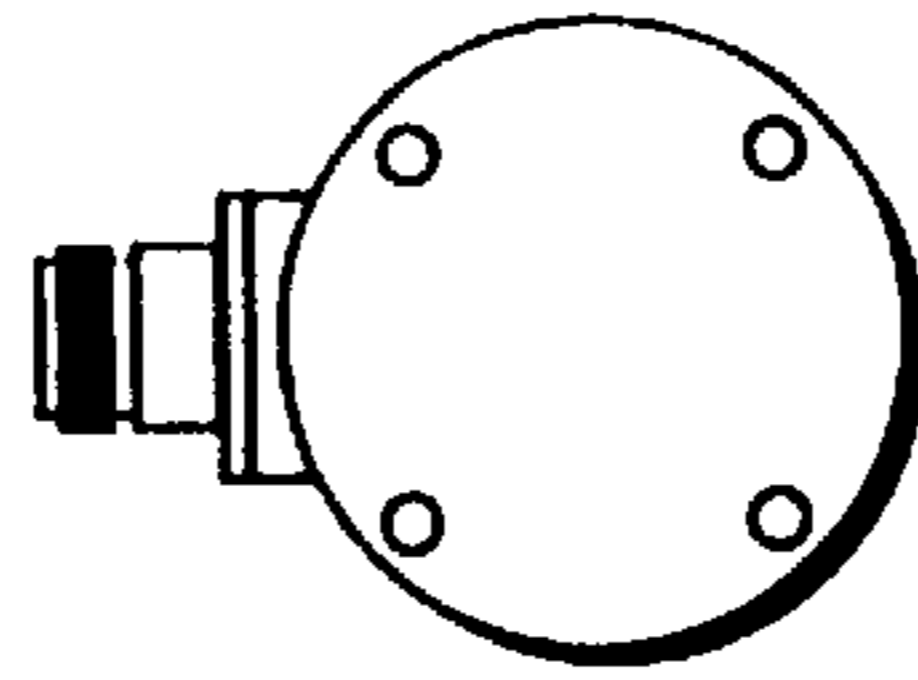

FIG. 4c

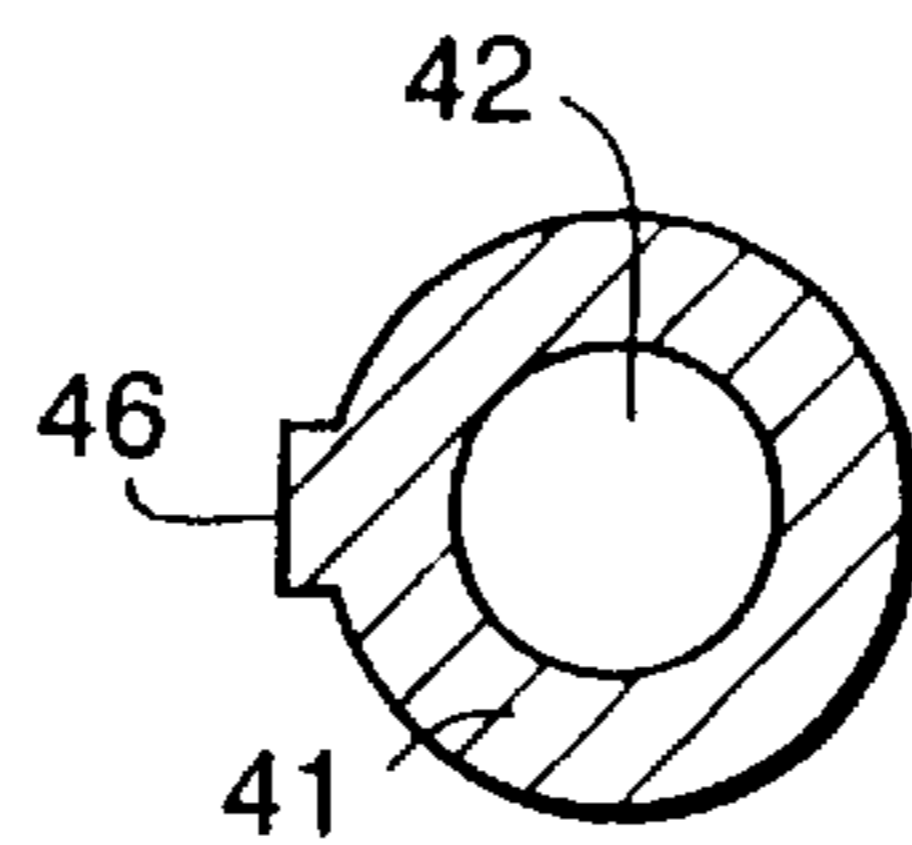

FIG. 4b

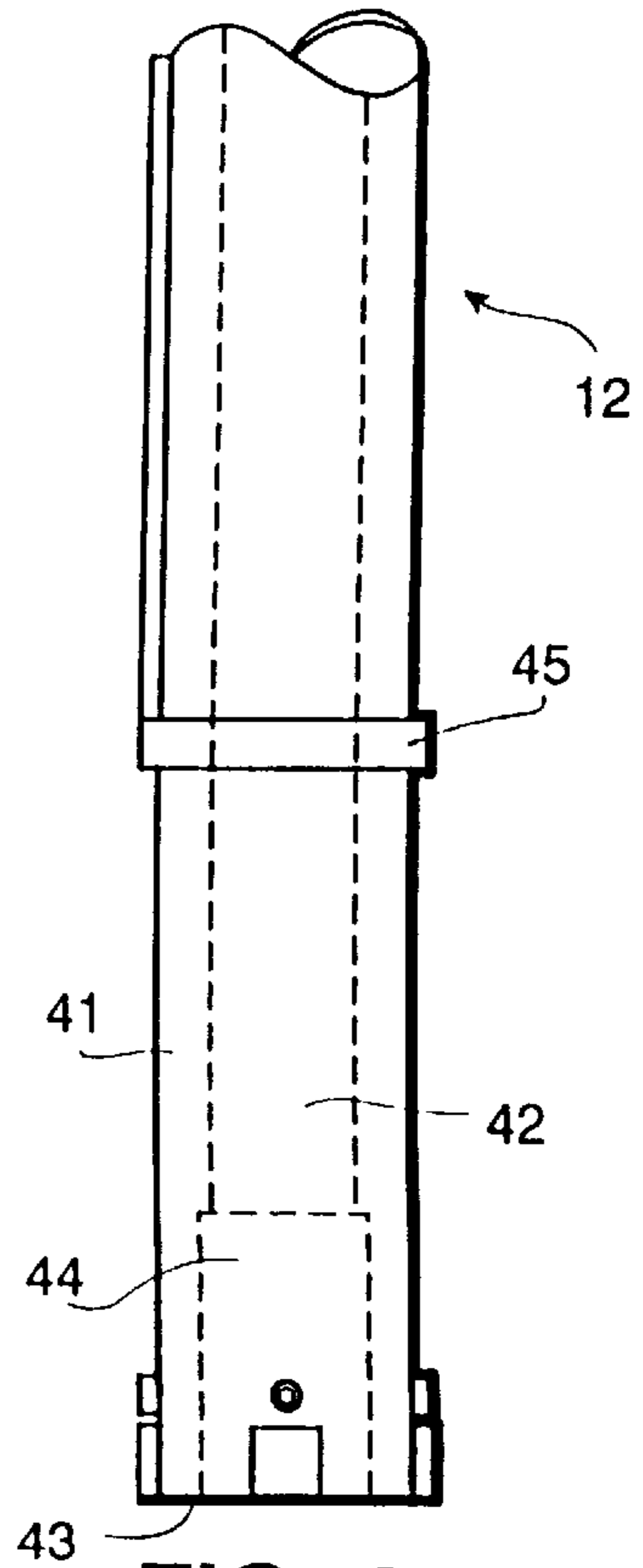
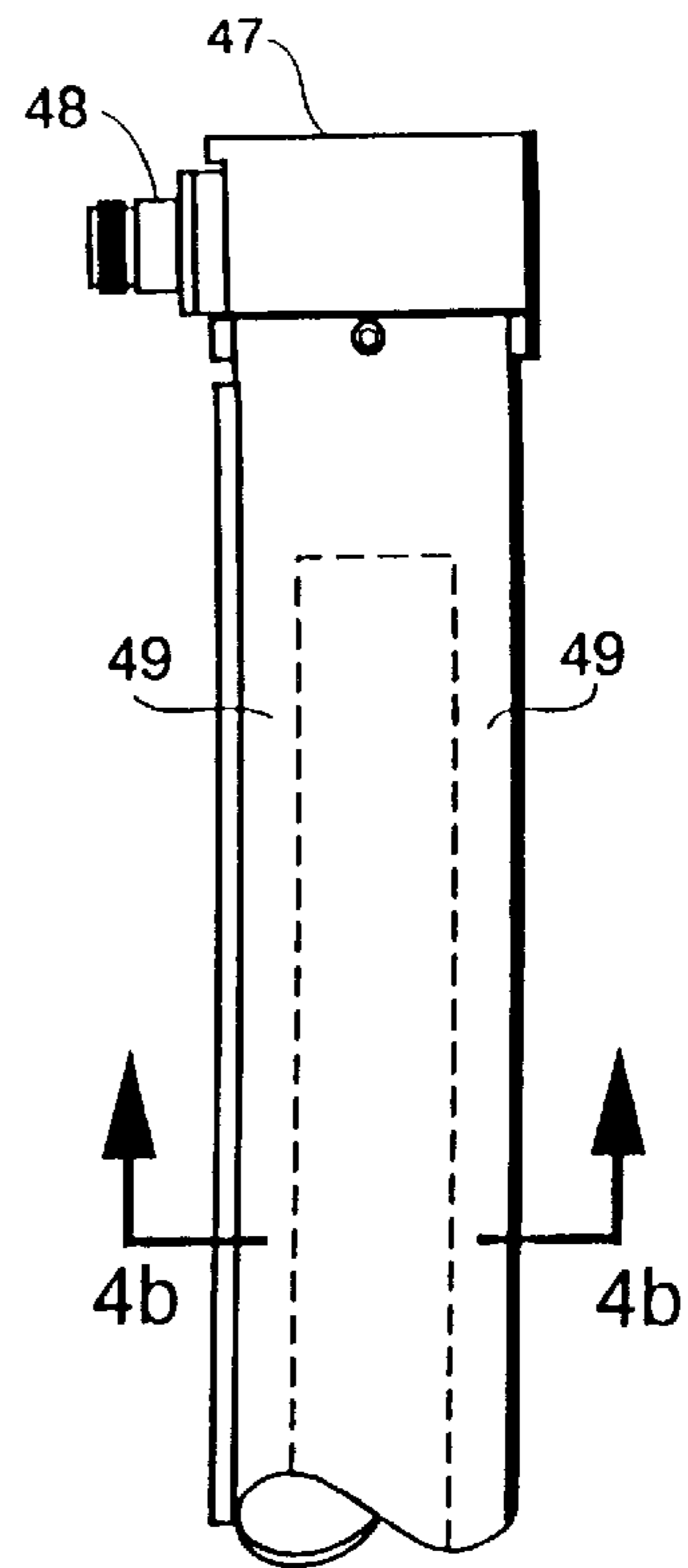

FIG. 4a



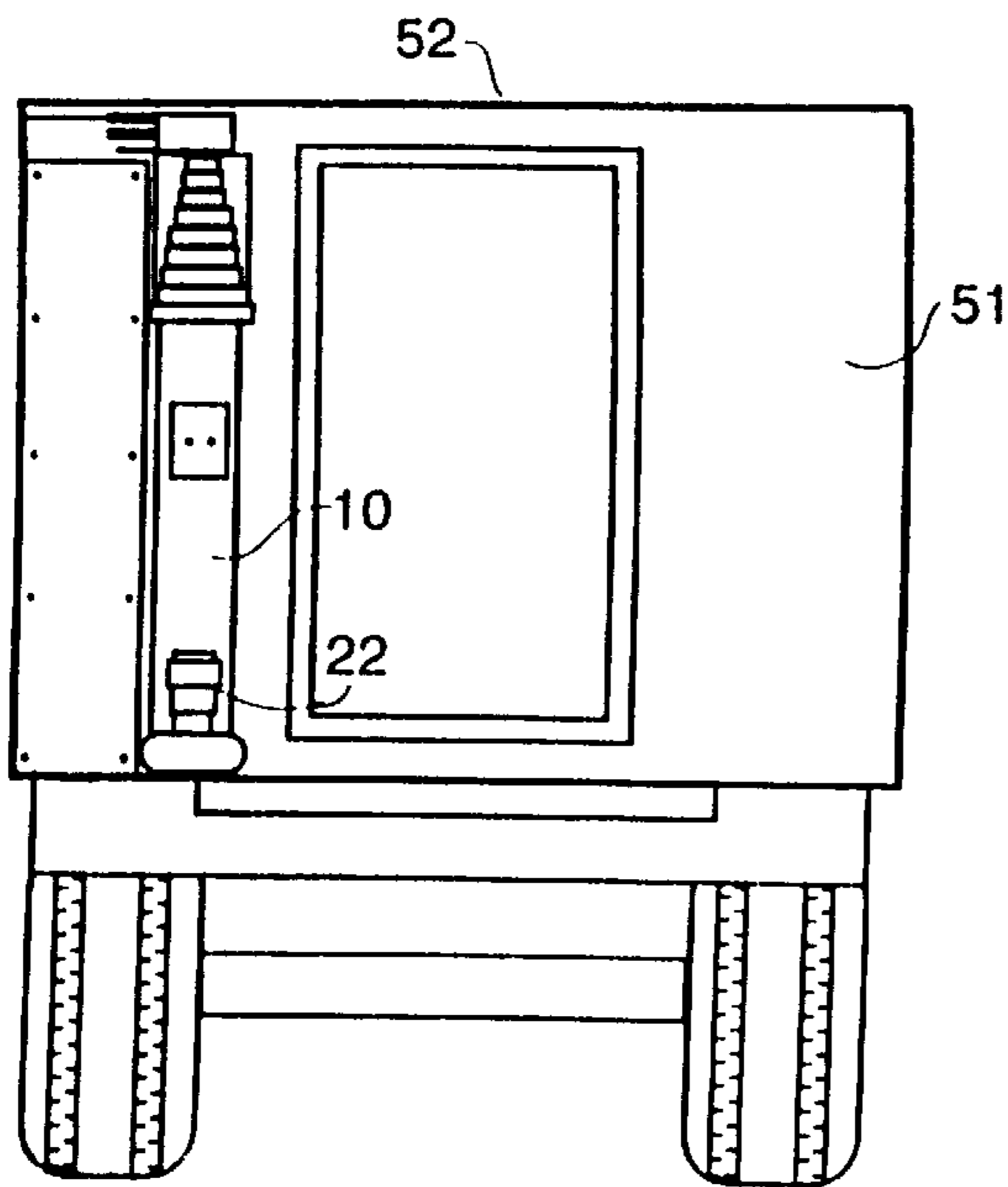

FIG. 5

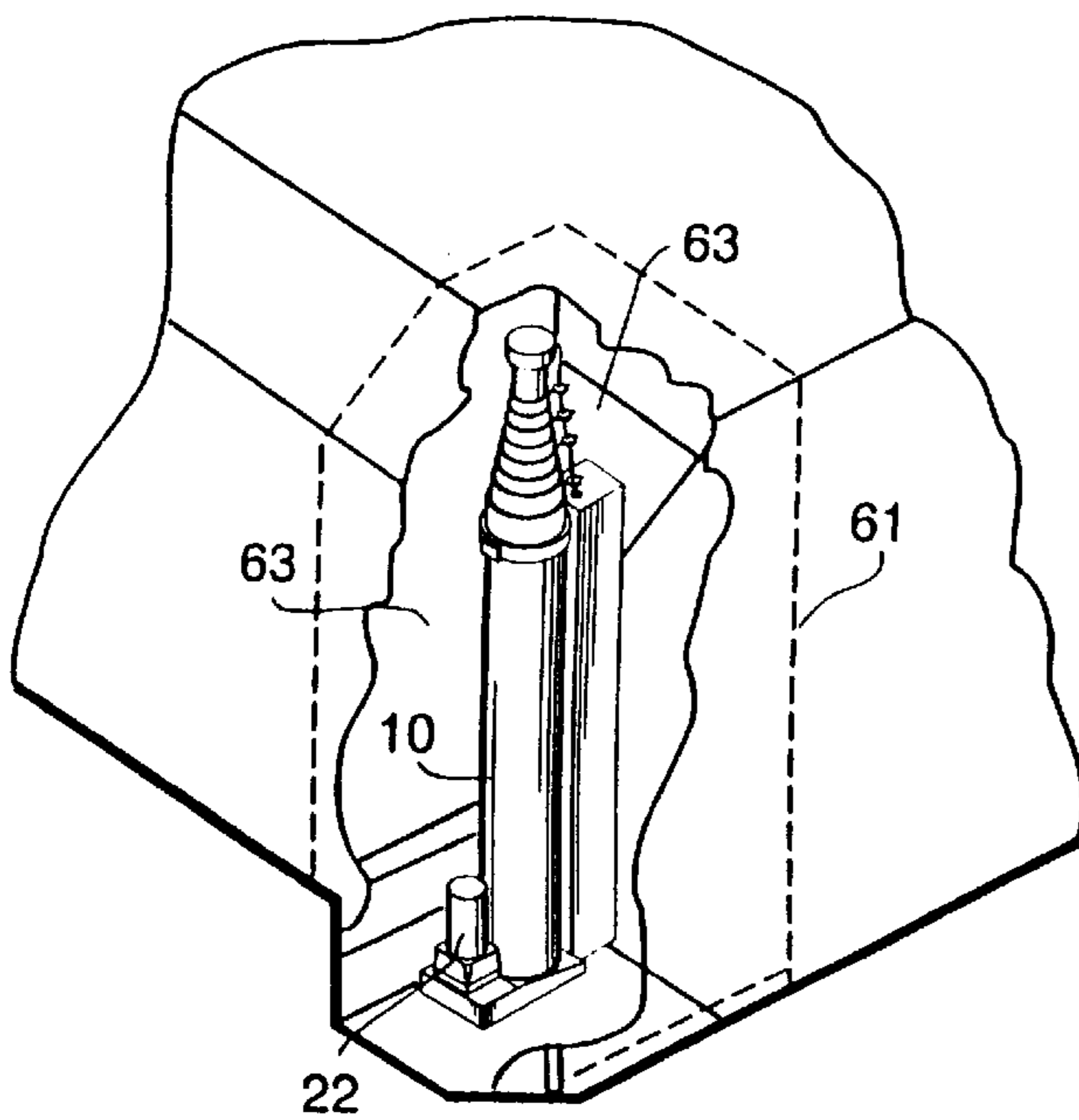

FIG. 6

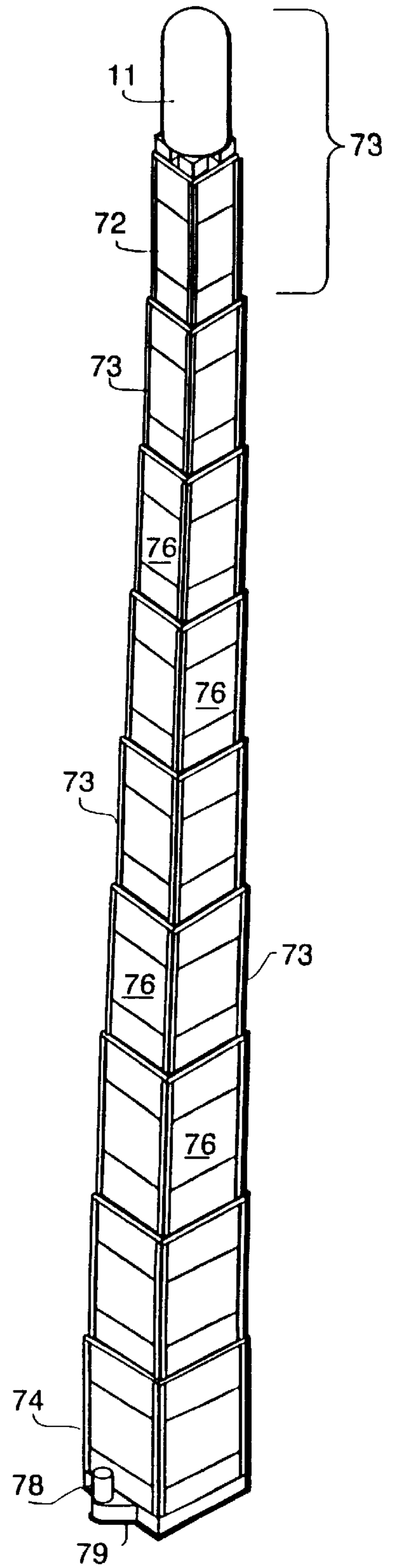

FIG. 7



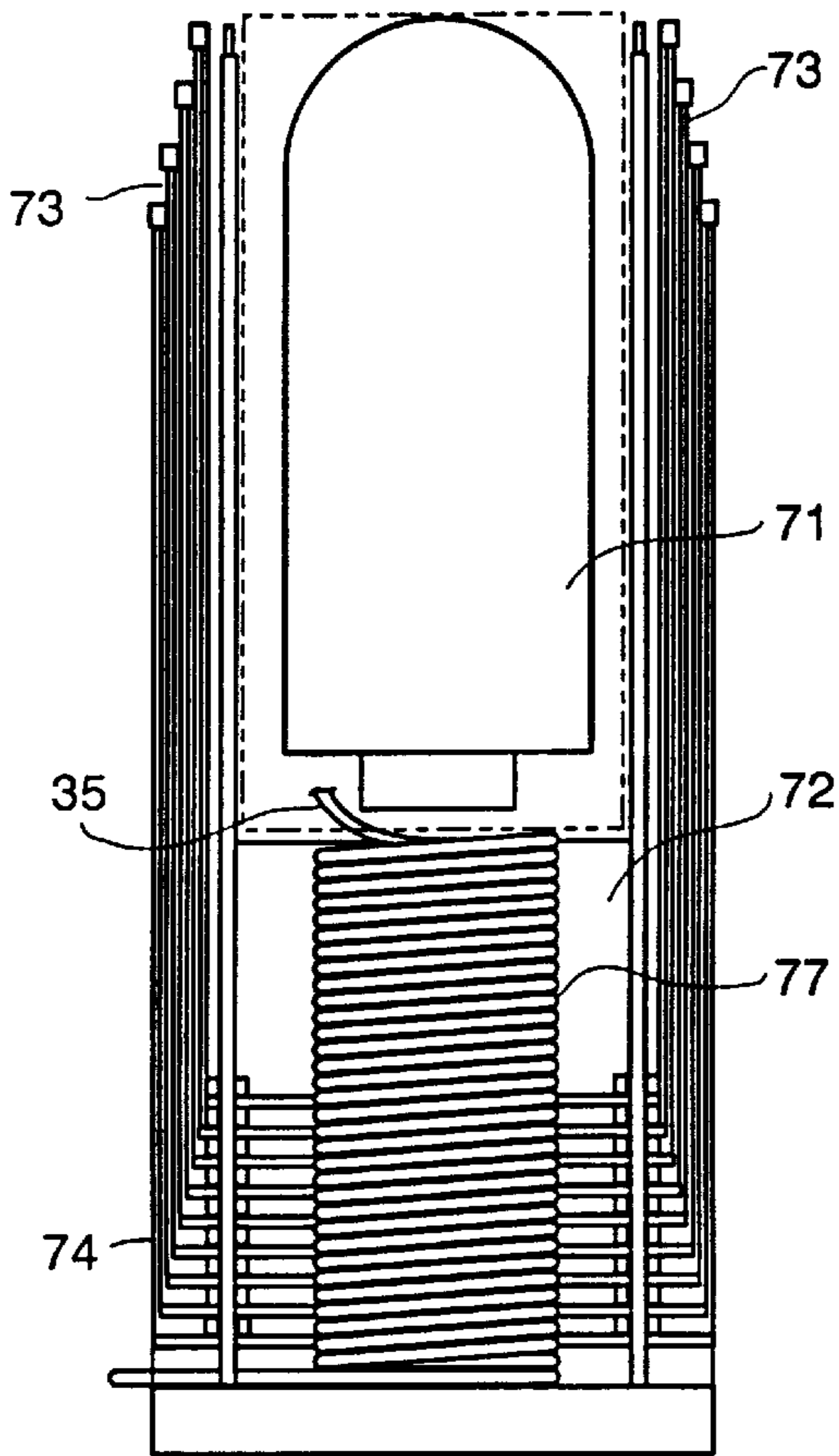

FIG. 8

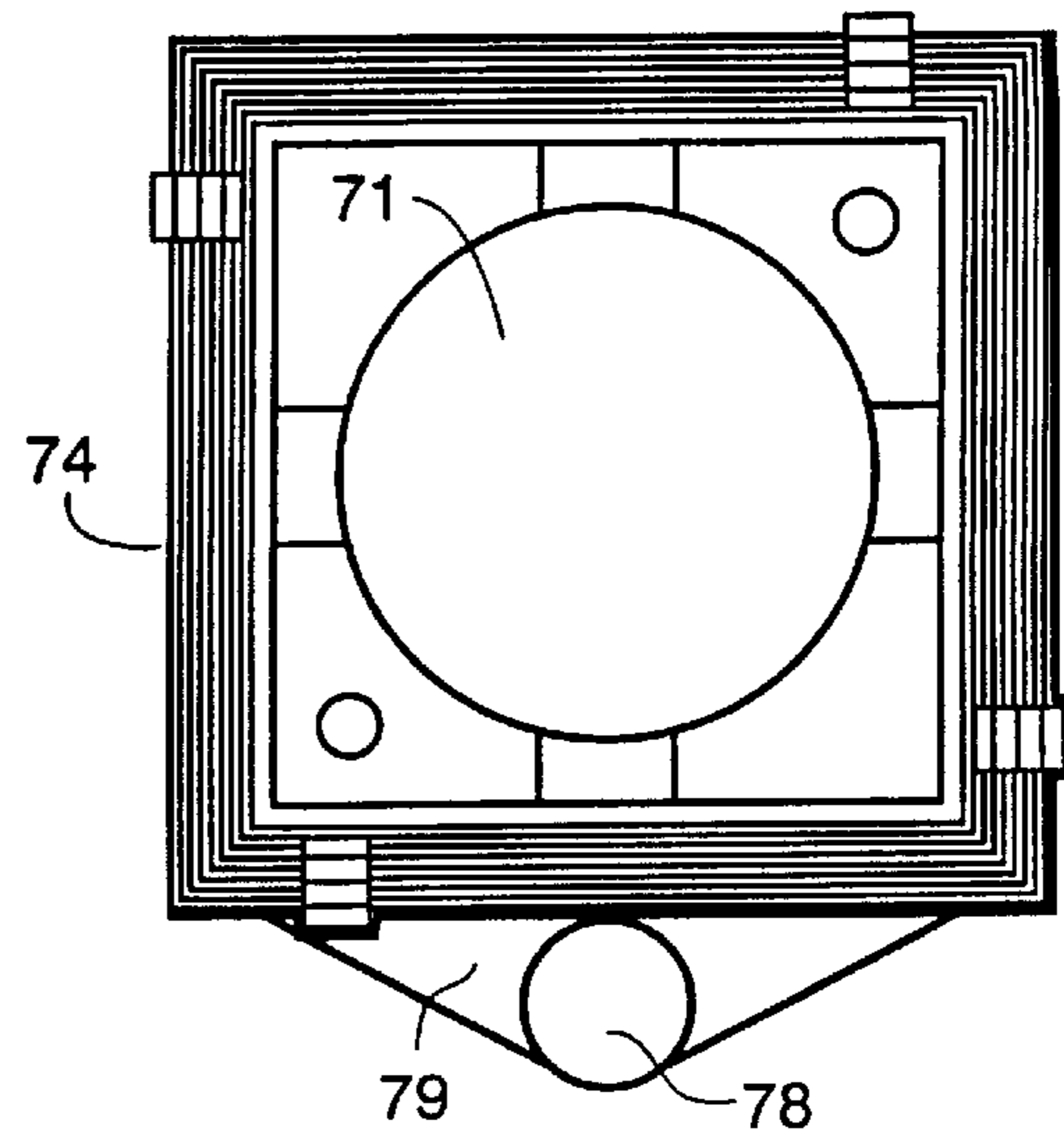

FIG. 10

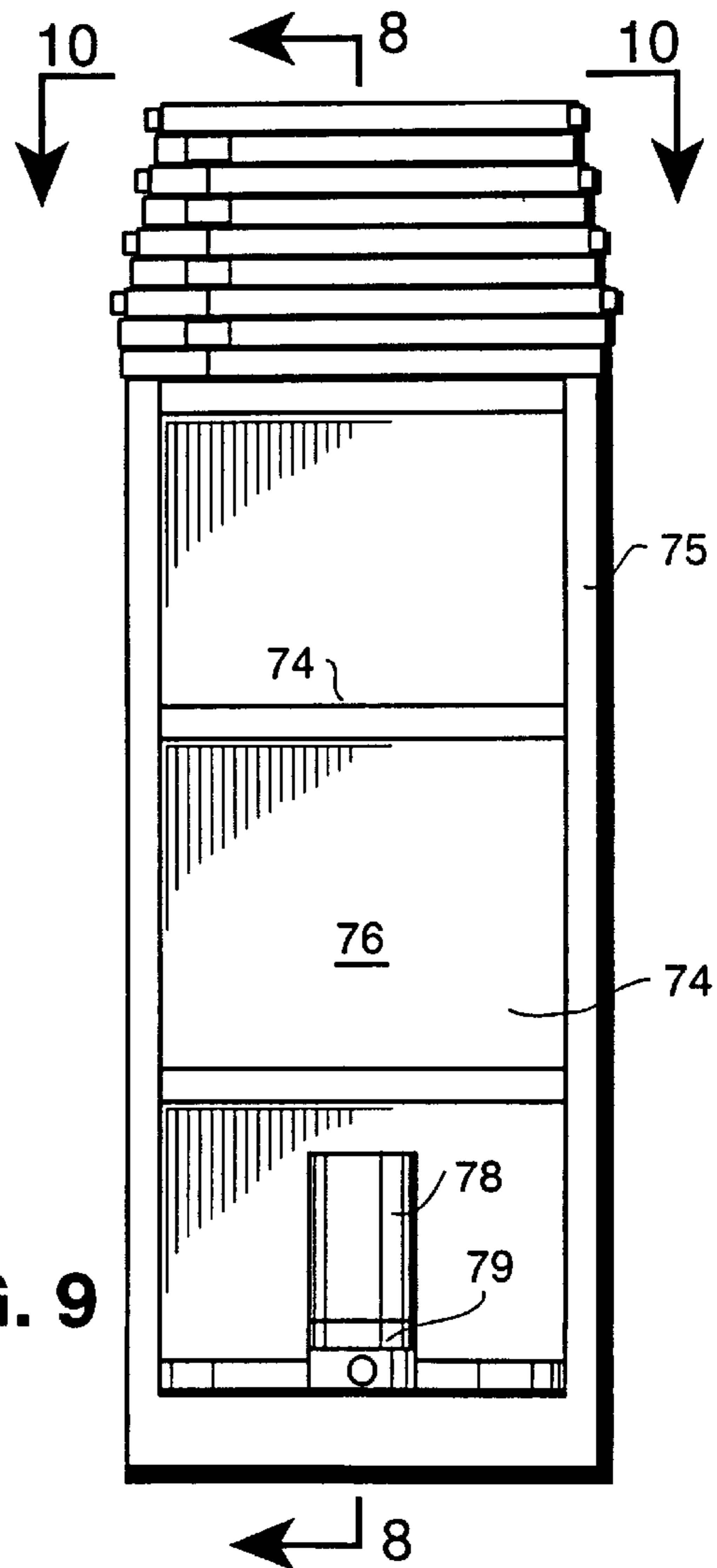
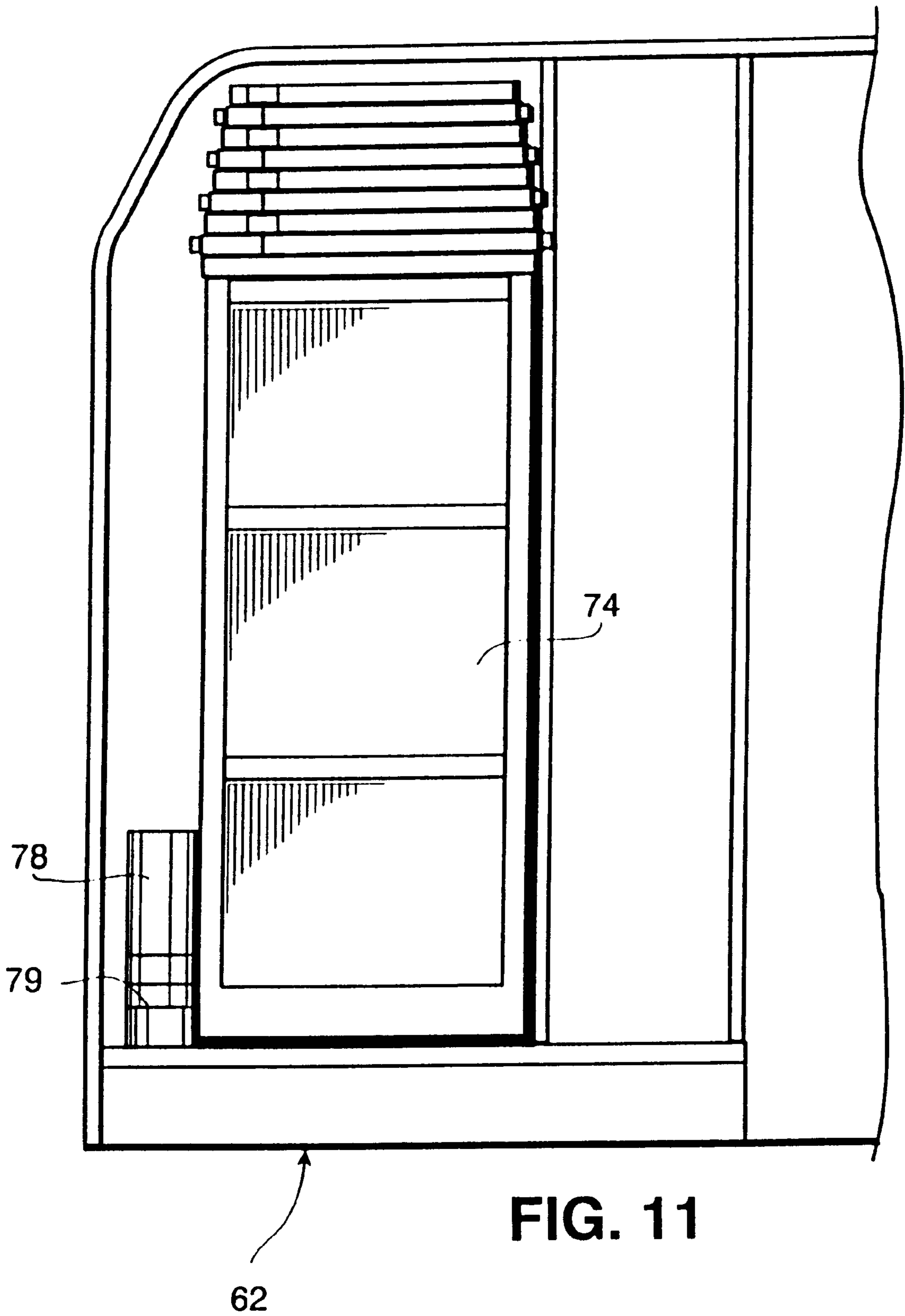

FIG. 9





## TELESCOPING MAST WITH INTEGRAL PAYLOAD

**Matter enclosed in heavy brackets [ ] appears in the original patent but forms no part of this reissue specification; matter printed in italics indicates the additions made by reissue.**

This application is a Reissue of application Ser. No. 08/353,118, filed Dec. 9, 1994, now U.S. Pat. No. 5,615,855, and copending with continuation application Ser. No. 09/596,850, filed Jun. 19, 2000, which is a CIP of PCT/US94/0354 filed Mar. 31, 1994 which is a Continuation-in-Part of the U.S. application Ser. No. 08/072,817, filed Jun. 7, 1993, now U.S. Pat. No. 5,593,129 issued Jan. 14, 1997 a national-stage application derived from PCT international application PCT/US92/08721, filed Oct. 6, 1992, which is, in turn, a Continuation-in-Part of U.S. application Ser. No. 07/772,167, filed Oct. 7, 1991, now U.S. Pat. No. 5,163,650, issued Nov. 17, 1992.

This invention relates to a telescoping mast which includes an integral payload.

More particularly, the invention pertains to an integrated telescoping mast-payload assembly which is specially adapted for mobile and portable use.

In another respect the invention relates to a telescoping mast-payload assembly which is specially configured for use under hazardous ambient conditions, in conjunction with protective shelters for operating personnel.

Telescoping masts have been widely employed for radio antennas, lights and a variety of other fixtures, such as instrumentation and telemetry packages for robotic vehicles, television cameras, mast-mounted antenna rotators, preamplifiers, radiation sensors and similar fragile electronic and electro-mechanical instrument packages.

Under extreme environmental conditions encountered during transport and use of portable telescoping masts which carry such fragile or environmentally sensitive packages, it would be highly desirable to provide improved mechanical, electrical and other forms of protection for the payload when the telescoping mast is retracted. Additionally, since the nested mast height and, in turn, the operational deployed height are often critical operational parameters of a telescoping mast, it would be desirable to provide a telescoping mast-payload assembly which provides minimum nested, (fully retracted) height and in turn, maximum deployed, (fully extended) operational height.

Accordingly, the principal object of the present invention is to provide an improved telescoping mast-payload assembly.

Still another object of the invention is to provide such an assembly which has minimum nested height and maximum deployable height for a given number of telescoping mast sections.

Yet another object of the invention is to provide such an integrated telescoping mast-payload assembly which is specially adapted for mobile or portable use.

A further object of the invention is to provide an integrated mast-payload assembly which protects the payload during storage and transportation while the mast is fully retracted.

A still further object of the invention is to provide an integrated mast-payload assembly which obviates the need to remove and reinstall the payload during transportation and in which there is no need for human interaction with the assembly to install or remove a payload during storage transportation or use.

This and other, further and more specific objects of the invention will be apparent to those skilled in the art from the

following detailed description, taken in conjunction with the drawings in which:

FIG. 1 is a perspective view of an integrated telescoping mast-payload assembly which embodies the present invention;

FIG. 2 is a cross-sectional view of the assembly of FIG. 1 taken along section 2—2 thereof;

FIG. 3 is a perspective cut-away view of the cable stowage-dispensing assembly of the embodiment of FIGS. 1—2;

FIGS. 4a—4c are, respectively, cut-away views of the radiating antenna element of the assembly of FIGS. 1—3, cross-sectional views thereof (along section line 4—4 of FIG. 4a) and the upper end view thereof;

FIG. 5 depicts the assembly of FIGS. 1—4, mounted externally on an operational vehicle, e.g., on the SICPS shelter of an HMMWV/CUCV transporter;

FIG. 6 depicts an alternate mobile installation of the assembly of 1—4, e.g., in the antenna mast cavity of a C2V Bradley vehicle;

FIG. 7 is a perspective view of another embodiment of the integrated telescoping mast-payload assembly of the present invention, in which the payload package does not have a central axial aperture, in which the mast sections have a polygonal cross-section and which utilizes multiple axial drive screws, and in which a cable assemble is enclosed internally of the mast and protected thereby;

FIG. 8 is a sectional view of the assembly of FIG. 7 in the fully retracted (nested) condition, taken along section line 8—8 of FIG. 9;

FIG. 9 is a side view of the assembly of FIGS. 7—8, with the mast fully retracted;

FIG. 10 is a sectional view of the assembly of FIGS. 8—9 taken along section line 10—10 thereof;

FIG. 11 is a cut-away rear view depicting a mast-payload assembly of FIGS. 7—10, mounted in the antenna mast cavity of a vehicle such as the Bradley C2V;

Briefly, in accordance with the broadest aspects of the invention, I provide an integrated telescoping mast-payload assembly comprising at least two or more nesting, telescoping mast sections, each section having an upper end and a lower end. The telescoping sections include one or more lower sections and a top section which is dimensioned to slidably nest within the next-lower section. Means are provided for extending and retracting the top section relative to the next-lower section and each of the lower sections relative to the section next below (except for the bottom section). A payload forms at least the upper end of the top section and at least a portion of the payload is received within the next-lower section when the top section is fully retracted. The lower section or sections provide protection for the payload when the top section is fully retracted.

According to a preferred embodiment, the assembly is mounted upon or in a vehicle or upon or in a transportable shelter.

In another presently preferred embodiment, the payload is an antenna for transmitting and/or receiving electro-magnetic energy such as radio signals.

In yet another preferred embodiment, one or more of the lower sections is radiopaque to shield the payload from stray electro-magnetic radiation, particularly EMP, when the assembly is retracted.

According to the best mode contemplated at present, the integrated mast-payload assembly includes means for mechanical locking the upper and lower sections together when the upper section is fully extended and when it is fully retracted, but preventing relative sequentially movement



between the sections when the upper section is between the fully retracted and fully extended positions.

In another preferred embodiment of the invention, when the nature of the payload prevents forming it with a central longitudinal parameter, a plurality of axial drive screws (at least two), are employed and these drive screws are laterally spaced from the longitudinal center line of the telescoping mast sections.

The drawings are provided to further illustrate to those skilled in the art how to make and use the invention and are not intended as a limitation on the scope of the invention. In the drawings, like reference characters identify the same elements in the several views.

Referring to FIGS. 1-3, the telescoping mast-payload assembly, generally indicated by reference numeral 10 includes a bottom mast section 11, a top mast section 12 and one or more lower sections 13-19. Each of the mast sections 12-19 is dimensioned to be slidably received within the next-lower section. The top section 12 and each of the one or more lower sections 13-19 can be extended and retracted relative to the next lower section from a fully retracted position, as shown in FIGS. 1-2 to a fully extended position (not shown). A single axial drive screw 21, which is rotated by operation of an electric motor 22 which transmits rotational force through a drive train 23, engages nuts 24 carried internally at the bottom end of each of the mast sections 12-19. Rotation of the axial drive screw 21 causes upward or downward movement of the nuts 24 on the drive screw 21 and corresponding relative motion of the mast section associated with each of the nuts 24. Holddown locking mechanisms 25 are provided to cause sequential deployment and retraction of each of the mast sections 12-19, to lock adjacent sections together when the mast is fully nested and when each section is fully extended relative to its next-lower section. A cable stowage/dispensing sub-assembly 31 includes an elongate frame 32, a moveable multi-sheave pulley 33 and a spring 34 connected to the pulley 33 which urges the pulley 33 downwardly in the direction of the arrow A. The transmission line cable 35 is connected at its upper end to the connector portion 36 of an antenna element 37 which forms the hollow antenna element which forms the upper section of the telescoping assembly 10. The transmission line passes into the frame 32 forming windings 38 on the moveable pulley 33 and stationary pulley 39. A terminal portion 41 of the cable 35 is fixed by means of a hook 42 to the frame 32 and passes through an outlet aperture 43 to its point of connection with another component, e.g., radio transceiver, (not shown). Further details of the operation of the drive components 21-24, the locking devices 25 and the cable stowage/dispensing assembly 32 are disclosed in the published international application No. PCT/US92/08721 (International Publication Number WO 93/07395, published 15 Apr. 1993), which is incorporated herein by reference.

FIGS. 4a-4c depict the top section 12 of the telescoping mast of FIGS. 1-3, the major length thereof being formed as a hollow cylinder 42 having a longitudinal bore 42. At the lower end 43 the diameter of the bore 42 is increased to provide a socket 44 which receives a nut which engages threads on the axial drive screw 21. The annular shoulder 45 cooperates with the locking mechanism on the upper end of mast section 13, in the manner previously described, a key 46 is formed as a longitudinal shoulder on the outer surface of the cylindrical section 41 to prevent rotation of the upper section 12. The upper end 47 of the top section 12 is provided with a coaxial connector 48 for attaching to rf transmission cable 35 with the rf rotated/receiving components which are embedded into side walls 49 of the top section 12.

FIG. 5 depicts the integrated mast-payload assembly 10 of FIGS. 1-4, mounted externally on the rear wall 51 of an SICPS shelter 52 carried on a suitable vehicle, e.g., the HMMWV/CUCV transporter. Alternatively, as depicted in FIG. 6, the assembly 10 can be mounted within a special radio antenna enclosure, indicated by the dash lines 61 of an enclosed vehicle such as the Bradley C2V. In either case, the electrical power lines, and control cables for the drive mechanism 22 and the coaxial cable 35 are routed through the bulkheads 51 (FIG. 5) or 63 (FIG. 6) to the interior of the vehicle, which protectively houses the human operators, such that the mast and payload can be extended and retracted from within vehicles 52, 62, without requiring personnel to operate outside these shelters.

Another embodiment of the invention is depicted in FIGS. 7-11. This embodiment is useful when the character of the payload does not permit it to be formed as a hollow cylinder (as shown in FIG. 4).

As shown in FIGS. 7-11, a complex payload such as the J-STARS SCDL antenna 71 is operatively mounted on a base 72. The antenna 71 and base 72 form the upper section 73 of a multi-section telescoping mast comprising a plurality of intermediate lower sections 73 and a bottom section 74, each of the sections 72-74 are formed of aluminum frame members 75, covered and stiffened by graphite composite panels 76. Alternatively, panels 76 can be omitted, thereby reducing the wind load on the mast. The extended assembly of FIG. 7 is shown in cross-section in FIGS. 8 and 10 and in a side view in FIG. 9. In the embodiment of FIG. 7-9, the antenna cable 35 is preformed as an extensible coil 77. Power to extend and retract the assembly is provided by an electric motor 78 and associated drive mechanism 79. As shown in FIG. 11, the assembly of FIGS. 7-10 can also be mounted internally of a radio antenna well 91 formed in an appropriate vehicle such as the C2V Bradley.

Having described the invention in such terms as to enable those skilled in the art to make and use it and having identified the presently known and preferred best modes thereof, I claim:

- [1. In a telescoping mast assembly, including:
  - a plurality of nesting, telescoping mast sections, including a top section and at least one lower section, each of said sections having upper and lower ends, and
  - means for extending and retracting each of said sections relative to the next-lower section,
 the improvement comprising:
  - a payload, located only in said top section,
  - said top section, including said payload, being dimensioned to be received and nest within the next-lower section,
  - at least a portion of said payload being received within said next-lower section when said top section is fully retracted,
  - such that said next-lower section provides protection for said payload when said top section is fully retracted, said payload being a member of the group consisting of radio antennas, lights, instrumentation and telemetry packages for robotic vehicles, television cameras, antenna rotators, preamplifiers, radiation sensors and electronic and electro-mechanical instrument packages.]
- [2. The assembly of claim 1 mounted on a vehicle.]
- [3. The assembly of claim 1, in which said payload is an antenna for electromagnetic energy.]
- [4. The assembly of claim 1, in which said lower section is radiopaque.]



5

- [5. The assembly of claim 1 which further includes:  
 (a) a transmission line cable for transmitting a signal to or from said payload; and  
 (b) a sub-assembly for stowing and dispensing said cable when said mast assembly is retracted and extended.]

6. A telescoping mast-payload assembly for reducing the retracted height of a mast-payload assembly and for providing protection of a payload when said mast-payload assembly is fully retracted, said mast-payload assembly comprising:

- (a) a telescoping mast component extending and retracting along the mast's longitudinal axis defining a mast axis, said telescoping mast component comprising:  
 a telescoping mast, adapted to telescope upwardly along said mast axis to an extended position and to telescope downwardly along said mast axis to a retracted position, said telescoping mast comprising:  
 a fixed bottom section being shaped and dimensioned to include a hollow region for telescopically receiving a next higher mast section;  
 a plurality of extending and retracting intermediate mast sections, each section having upper and lower ends and being shaped and dimensioned to include a hollow region for telescopically receiving the next higher mast section; and  
 an extending and retracting payload section defining the top section of said telescoping mast, said payload section shaped and dimensioned to be telescopically received within the hollow region of the uppermost section of said intermediate sections;

said intermediate support sections and said payload section being constructed to telescopically retract along said mast axis within the hollow region of the next lower mast section and to telescopically extend along said mast axis above the next lower mast section, said plurality of intermediate support sections supporting said payload section when said mast is extended to said extended position and receiving and protecting said payload section when said top section is fully retracted; and

- (b) a payload component of said assembly forming at least a portion of said payload section and being located only in said payload section, said payload component being shaped and dimensioned to extend along said mast axis to be supported above the next-lower support section when said mast-payload assembly is extended to said extended position and to retract along said mast axis and to be at least partially received and protected within said intermediate support sections when said mast is fully retracted.

7. The telescoping mast-payload assembly of claim 6 wherein the payload is a member of the group consisting of radio antennas, lights, television cameras, antenna rotators, preamplifiers, radiation sensors, instrumentation and telemetry packages for robotic vehicles, and electronic and electro-mechanical instrument packages.

8. The telescoping mast-payload assembly of claim 6 wherein the payload is a radio antenna.

9. The telescoping mast-payload assembly of claim 8 being mounted on a vehicle.

10. The telescoping mast-payload assembly of claim 6 being mounted on a vehicle.

11. The telescoping mast-payload assembly of claim 6, further including motor drive means for extending and retracting said payload section and said intermediate support sections relative to said bottom section.

6

12. A telescoping mast-payload assembly for reducing the retracted height of a mast-payload assembly and for providing protection of a payload when said mast-payload assembly is fully retracted, said mast-payload assembly comprising:

- (a) a telescoping mast component extending and retracting along the mast's longitudinal axis defining a mast axis, said telescoping mast component comprising:  
 a telescoping mast, adapted to telescope upwardly along said mast axis to an extended position and to telescope downwardly along said mast axis to a retracted position, said telescoping mast comprising:  
 a fixed bottom section being shaped and dimensioned to include a hollow region for telescopically receiving a next higher mast section;  
 a plurality of extending and retracting intermediate mast sections, each section having upper and lower ends and being shaped and dimensioned to include a hollow region for telescopically receiving the next higher mast section; and  
 an extending and retracting payload section defining the top section of said telescoping mast, said payload section shaped and dimensioned to be telescopically received within the hollow region of the uppermost section of said intermediate sections;

said intermediate support sections and said payload section being constructed to telescopically retract along said mast axis within the hollow region of the next lower mast section and to telescopically extend along said mast axis above the next lower mast section, said plurality of intermediate support sections supporting said payload section when said mast is extended to said extended position and receiving and protecting said payload section when said mast is fully retracted;

- (b) a payload component of said assembly forming at least a portion of said payload section and being located only in said payload section, said payload section being shaped and dimensioned to extend along said mast axis to be supported above the next-lower support section, when said mast-payload assembly is extended to said extended position and to retract along said mast axis and to be at least partially received and protected within said intermediate support sections when said mast is fully retracted; and

(c) motor drive means for extending and retracting said payload section and said intermediate support sections relative to said bottom section.

13. The telescoping mast-payload assembly of claim 12 wherein the payload is a member of the group consisting of radio antennas, lights, television cameras, antenna rotators, preamplifiers, radiation sensors, instrumentation and telemetry packages for robotic vehicles, and electronic and electro-mechanical instrument packages.

14. The telescoping mast-payload assembly of claim 13 being mounted on a vehicle.

15. The telescoping mast-payload assembly of claim 13 wherein the payload is a radio antenna.

16. The telescoping mast-payload assembly of claim 15 being mounted on a vehicle.

17. The telescoping mast-payload assembly of claim 12 further comprising:

- a transmission line cable for transmitting a signal to or from said payload; and  
 a subassembly for stowing and dispensing said cable when said mast assembly is retracted and extended.



18. A vehicular mounted telescoping mast-payload assembly for reducing the retracted height of a mast-payload assembly and for providing protection of a payload when said mast-payload assembly is fully retracted, said mast-payload assembly comprising:

(a) a telescoping mast component extending and retracting along the mast's longitudinal axis defining a mast axis, said telescoping mast component comprising:

a telescoping mast, adapted to telescope upwardly along said mast axis to an extended position and to telescope downwardly along said mast axis to retracted position, said mast comprising:

a fixed bottom section being shaped and dimensioned to include a hollow region for telescopically receiving a next higher mast section;

an extending and retracting intermediate mast section, said section having an upper and lower end and being shaped and dimensioned to include a hollow region for telescopically receiving a next higher mast section; and

an extending and retracting payload section defining the top section of said telescoping mast, said payload section shaped and dimensioned to be telescopically received within the hollow region of the uppermost section;

said intermediate support sections and said payload section being constructed to telescopically retract along said mast axis within the hollow region of the next lower mast section and to telescopically extend along said mast axis above the next lower mast section, said intermediate support section supporting said payload section when said mast is extended to said extended position and receiving and protecting said payload section when said mast is fully retracted;

(b) a payload component of said assembly forming at least a portion of said payload section and being located only in said payload section, said payload component being shaped and dimensioned to extend along said mast axis to be supported above the next-lower support section when said mast-payload assembly is extended to said extended position and to retract along said mast axis and to be at least partially received and protected within said intermediate support section when said mast is fully retracted; and

(c) attachment means for attaching said bottom section to a vehicle.

19. The telescoping mast-payload assembly of claim 18 wherein the payload is a member of the group consisting of radio antennas, lights, television cameras, antenna rotators, preamplifiers, radiation sensors, instrumentation and telemetry packages for robotic vehicles, and electronic and electro-mechanical instrument packages.

20. The telescoping mast-payload assembly of claim 19 further comprising:

a transmission line cable for transmitting a signal to or from said payload; and

a subassembly for stowing and dispensing said cable when said mast assembled is retracted and extended.

21. The telescoping mast-payload assembly of claim 18 wherein the payload is a radio antennae.

22. The telescoping mast-payload assembly of claim 18, further including motor drive means for extending and retracting said payload section and said intermediate support section relative to said bottom section.

\* \* \* \* \*