



US00RE37549E

(19) **United States**
(12) **Reissued Patent**
Mahendran et al.

(10) **Patent Number: US RE37,549 E**
(45) **Date of Reissued Patent: Feb. 19, 2002**

(54) **VERTICAL SKEIN OF HOLLOW FIBER MEMBRANES AND METHOD OF MAINTAINING CLEAN FIBER SURFACES WHILE FILTERING A SUBSTRATE TO WITHDRAW A PERMEATE**

5,403,479 A * 4/1995 Smith et al. 210/636
5,480,553 A * 1/1996 Yamamori et al. 210/650
5,607,593 A * 3/1997 Cote et al. 210/650

(75) Inventors: **Mailvaganam Mahendran**, Hamilton;
Carlos Fernando F. Rodrigues,
Brampton; **Steven Kristian Pedersen**,
Mississauga, all of (CA)

FOREIGN PATENT DOCUMENTS

JP 61-107905 * 5/1986 210/500.23
JP 62-201610 * 9/1987 210/500.23
JP 63-143905 * 6/1988
SU 1692626 * 11/1991 210/500.23

(73) Assignee: **Zenon Environmental Inc.**, Oakville
(CA)

OTHER PUBLICATIONS

Translated Abstract for Japan document #63-143,905, Jun. 1988.*

(*) Notice: This patent issued on a continued prosecution application filed under 37 CFR 1.53(d), and is subject to the twenty year patent term provisions of 35 U.S.C. 154(a)(2).

* cited by examiner

Primary Examiner—Joseph W. Drodge
(74) *Attorney, Agent, or Firm*—Alfred D. Lobo

(21) Appl. No.: **09/333,669**

(57) **ABSTRACT**

(22) Filed: **Jun. 15, 1999**

A vertical skein of “fibers”, opposed terminal portions of which are held in headers unconfined in a modular shell, is aerated with a gas-distribution means which produces a mass of bubbles serving the function of a scrub-brush for the outer surfaces of the fibers. The membrane device is surprisingly effective with relatively little cleansing gas, the specific flux through the membranes reaching an essentially constant relatively high value because the vertical deployment of fibers allows bubbles to rise upwards along the outer surfaces of the fibers. Further, bubbles flowing along the outer surfaces of the fibers make the fibers surprisingly resistant to being fouled by build-up of deposits of inanimate particles or microorganisms in the substrate provided that the length of each fiber is only slightly greater than the direct center-to-center distance between opposed faces of the headers, preferably in the range from at least 0.1% to about 5% greater. For use in a large reservoir, a bank of skeins is used with a gas distributor means and each skein has fibers preferably >0.5 meter long, which together provide a surface area >10 m². The terminal end portions of fibers in each header are kept free from fiber-to-fiber contact with a novel method of potting fibers.

Related U.S. Patent Documents

Reissue of:

(64) Patent No.: **5,639,373**
Issued: **Jun. 17, 1997**
Appl. No.: **08/514,119**
Filed: **Aug. 11, 1995**

(51) **Int. Cl.**⁷ **B01D 65/02**
(52) **U.S. Cl.** **210/636; 210/321.69; 210/321.8; 210/500.23; 210/356; 264/258**
(58) **Field of Search** 210/220, 355, 210/356, 257.2, 321.69, 321.79, 321.8, 321.85, 321.89, 500.23, 636, 641, 650; 264/258

(56) **References Cited**

U.S. PATENT DOCUMENTS

3,708,071 A * 1/1973 Crowley et al. 210/500.23
4,647,377 A * 3/1987 Miura et al. 210/500.23
5,248,424 A * 9/1993 Cote et al. 210/636

29 Claims, 12 Drawing Sheets

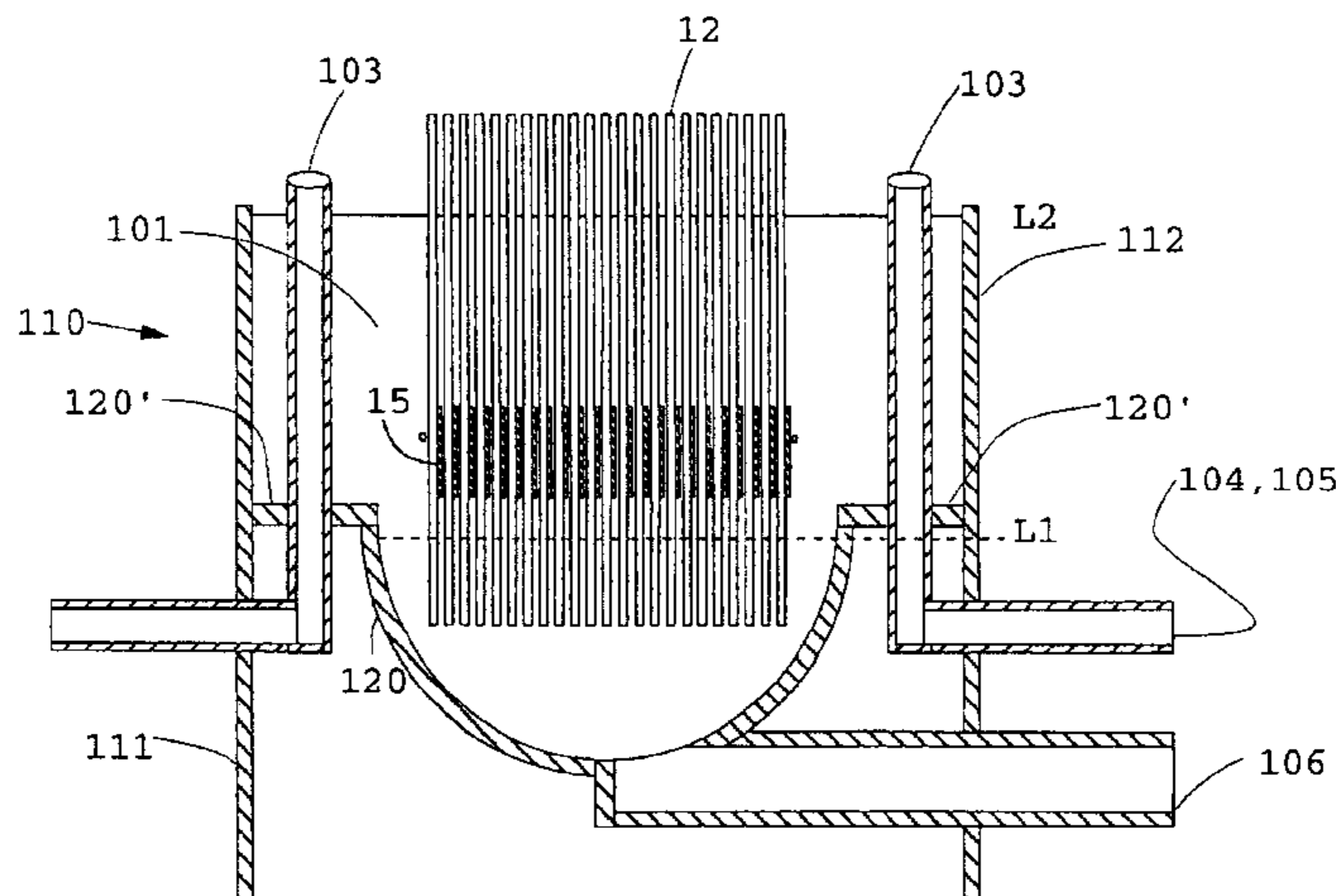

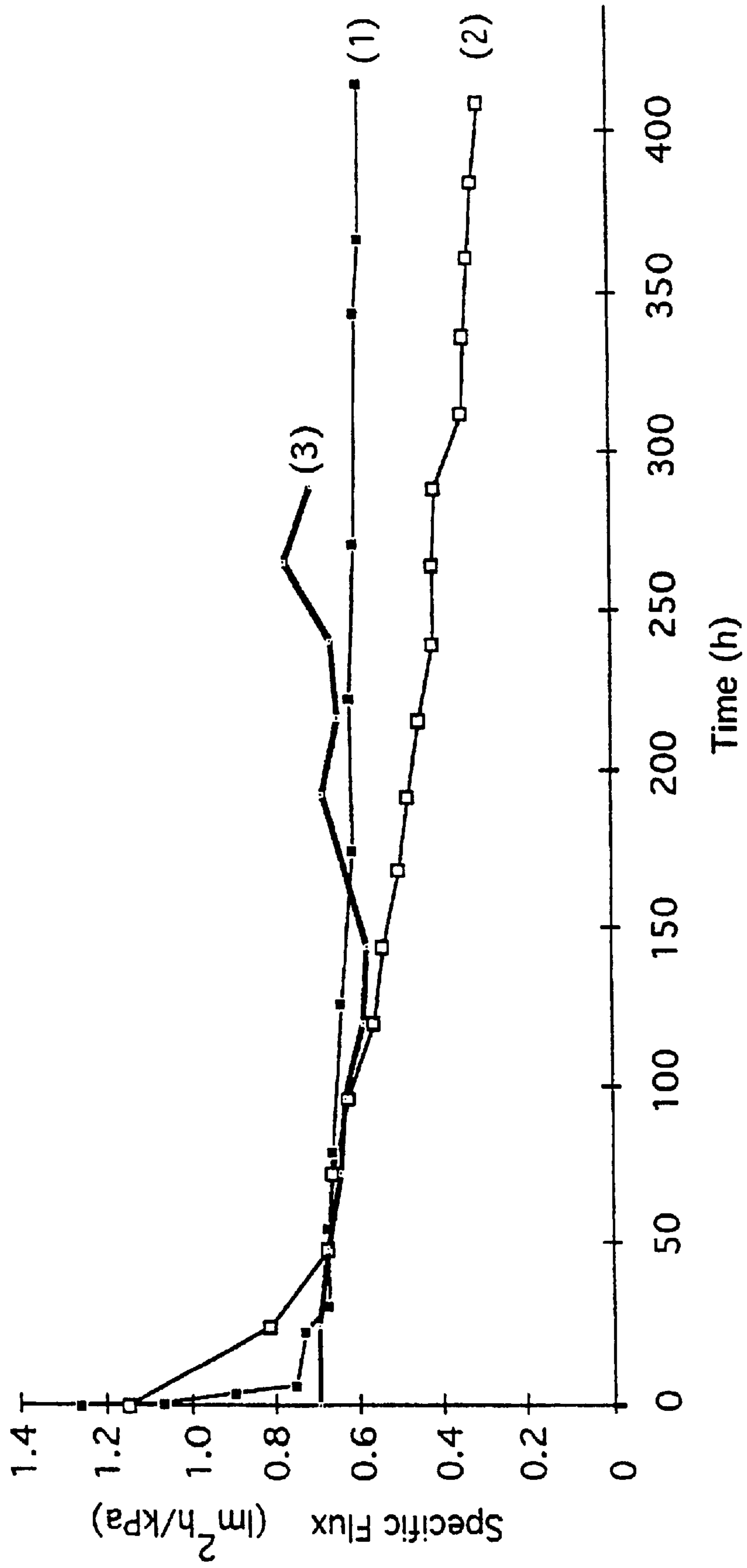

Figure 1

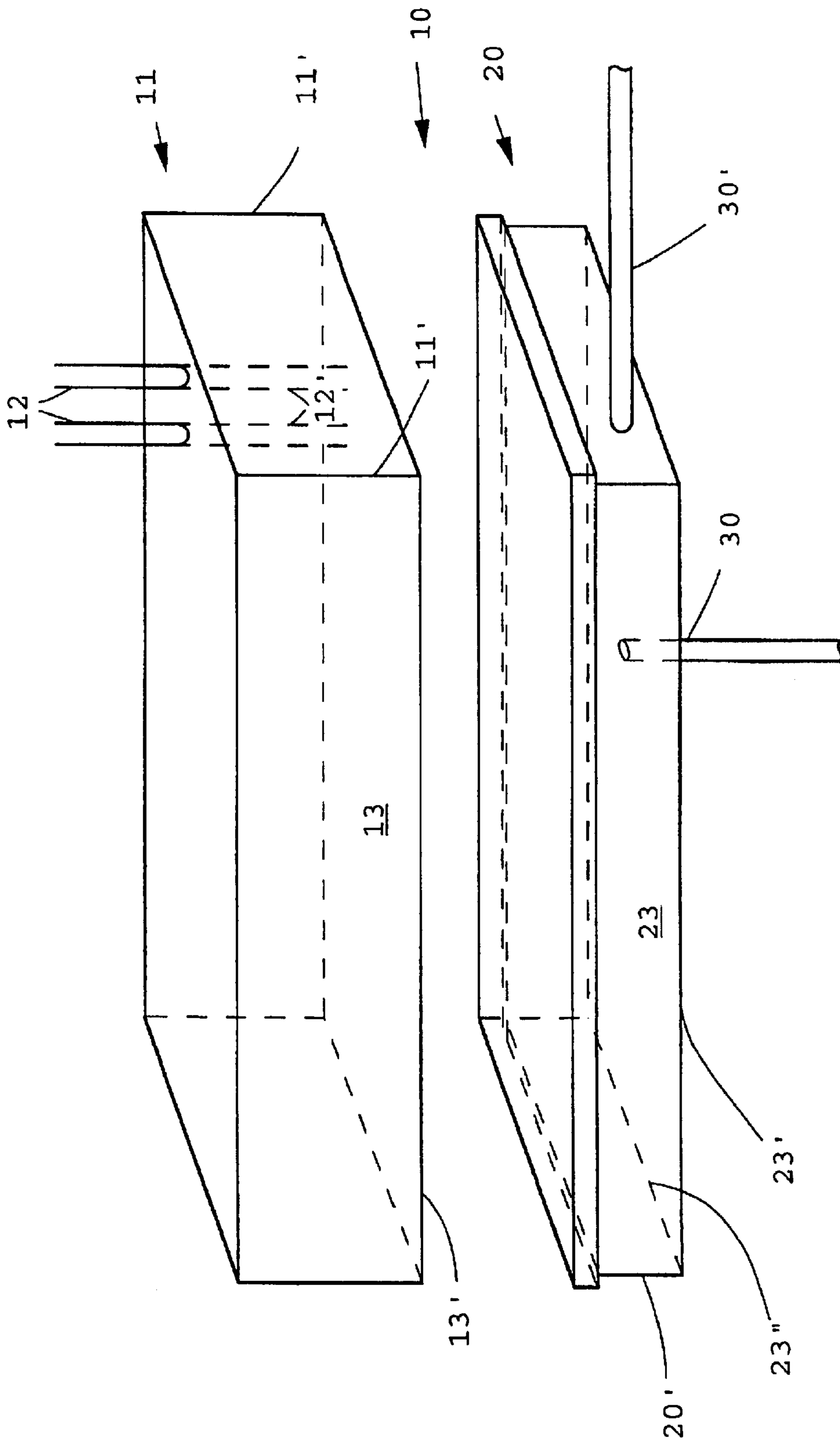

FIG. 2

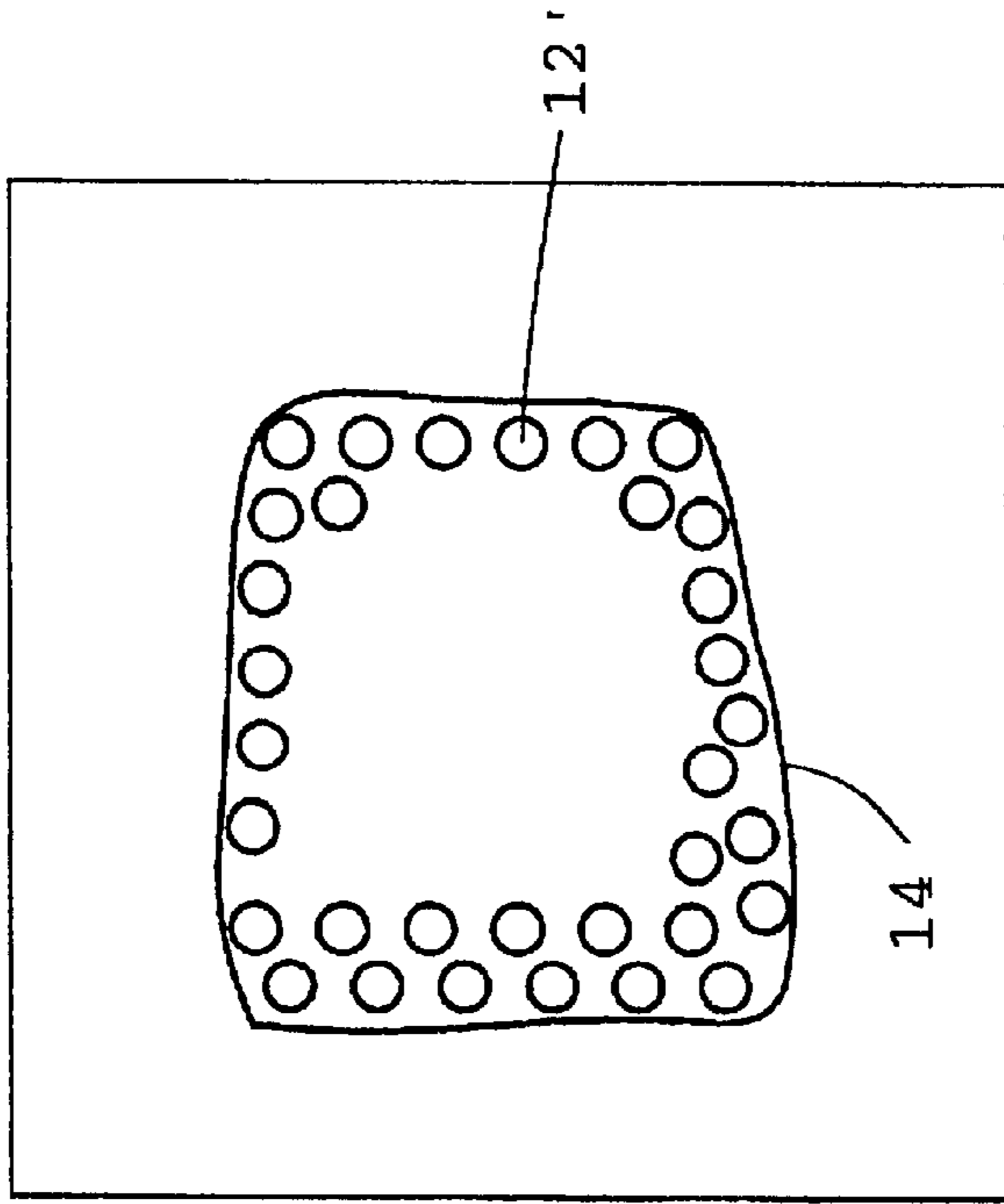

FIG. 2A

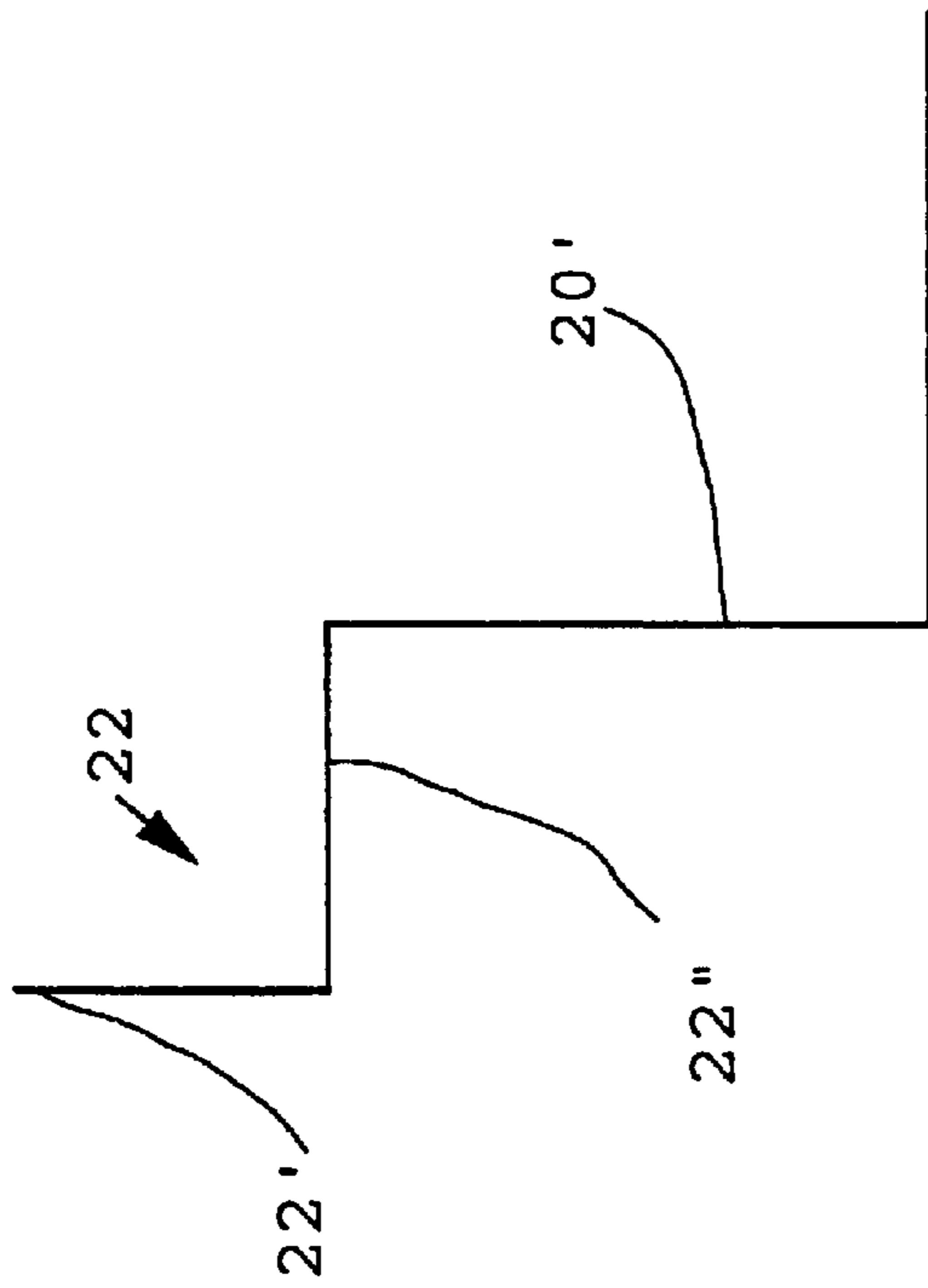

FIG. 2B

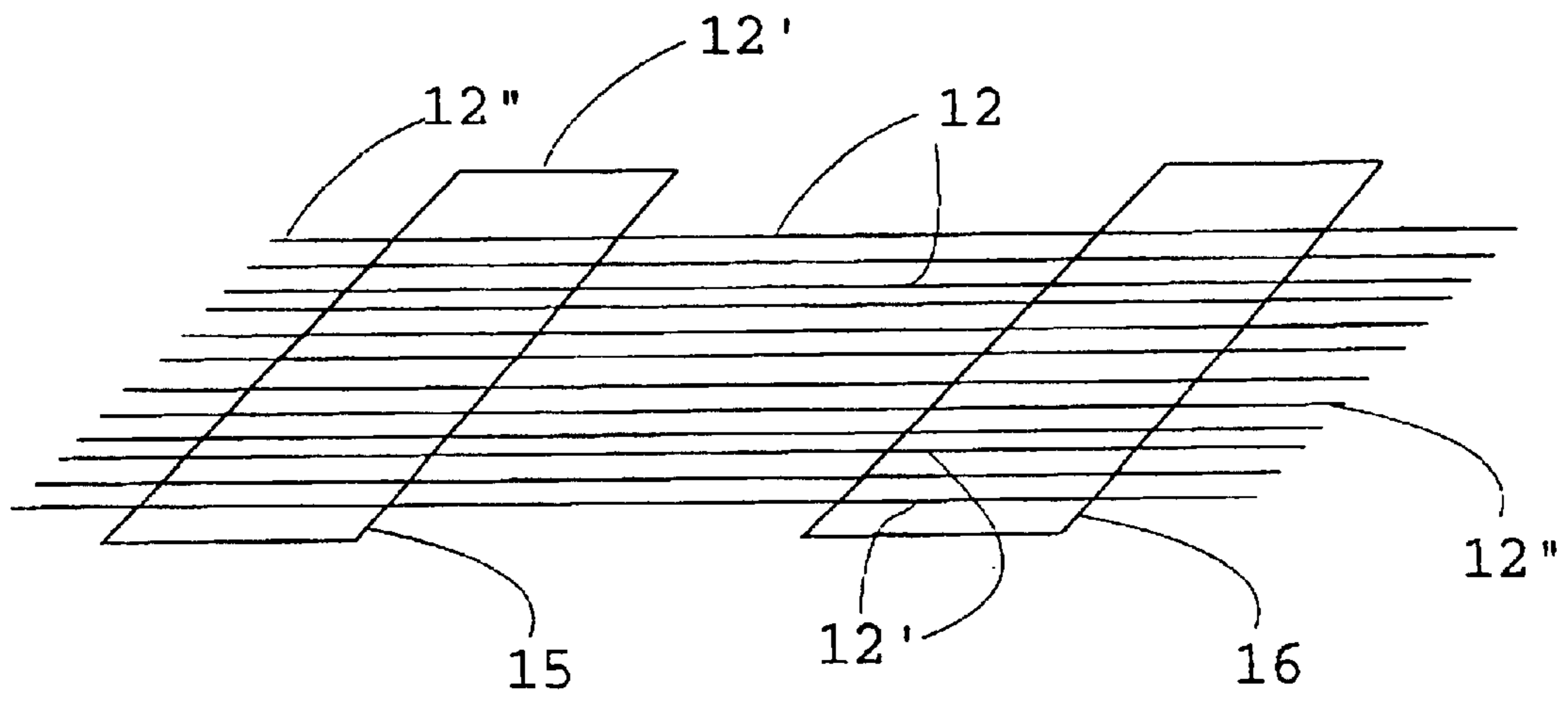

FIG. 3

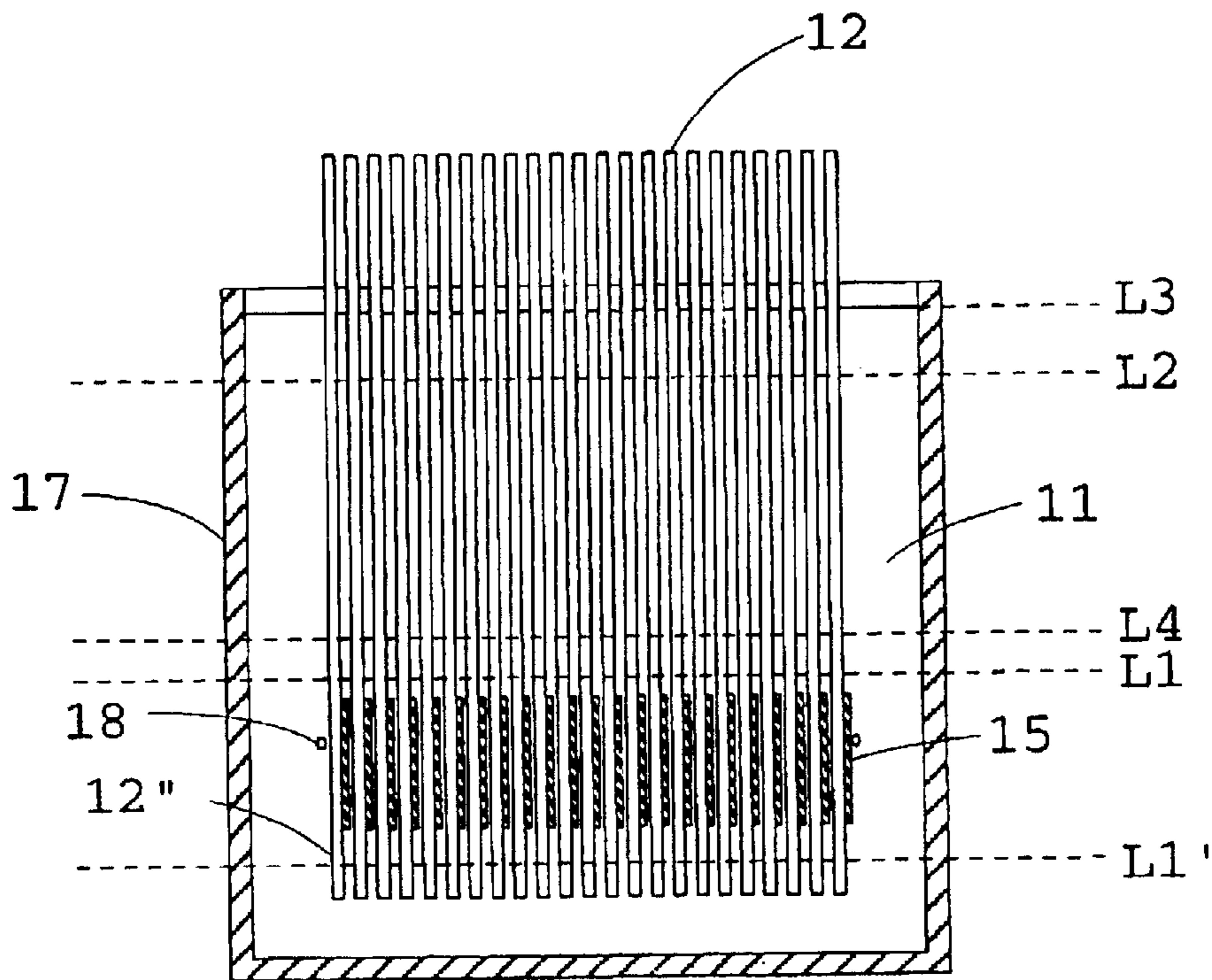

FIG. 4

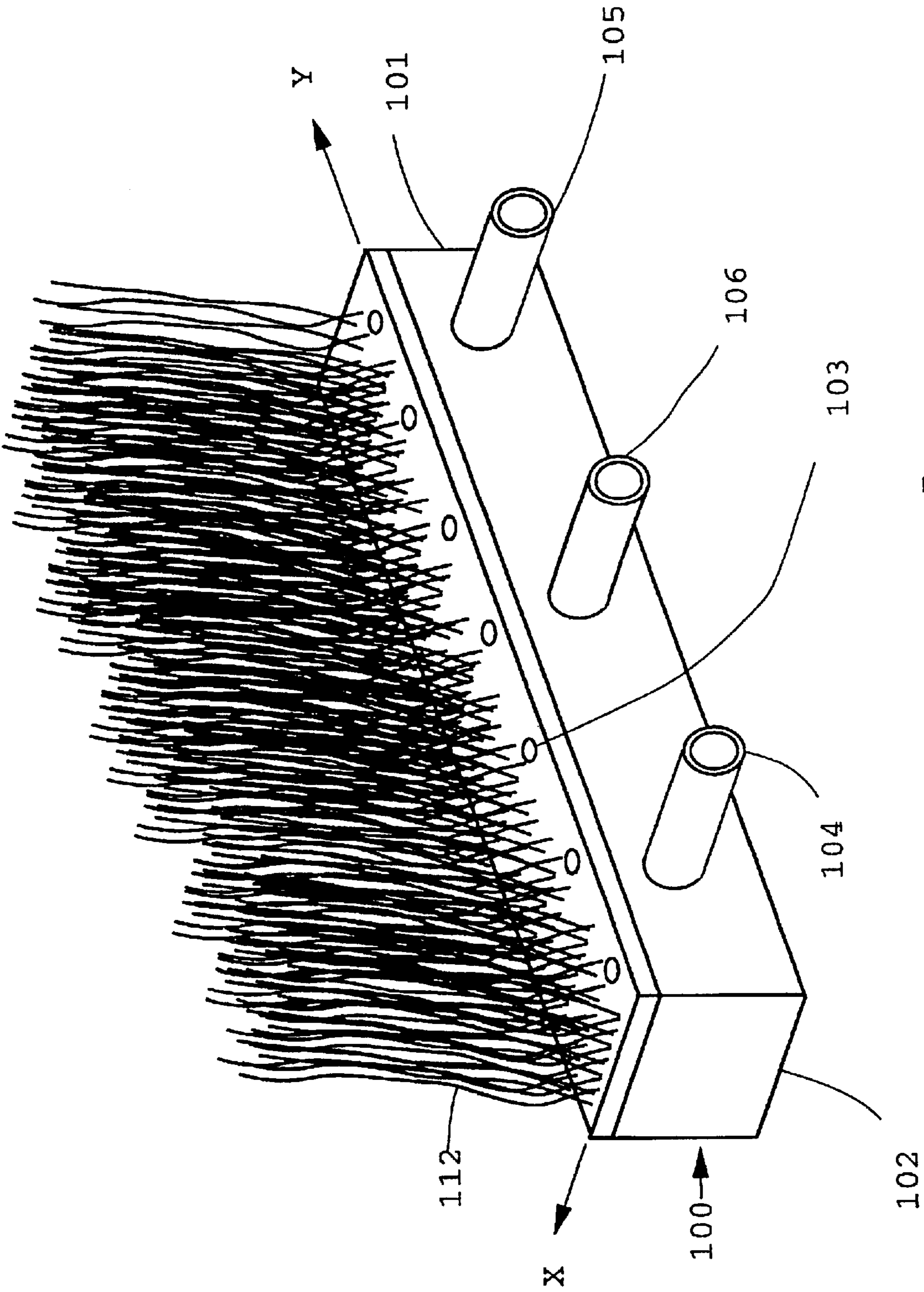

FIG. 5

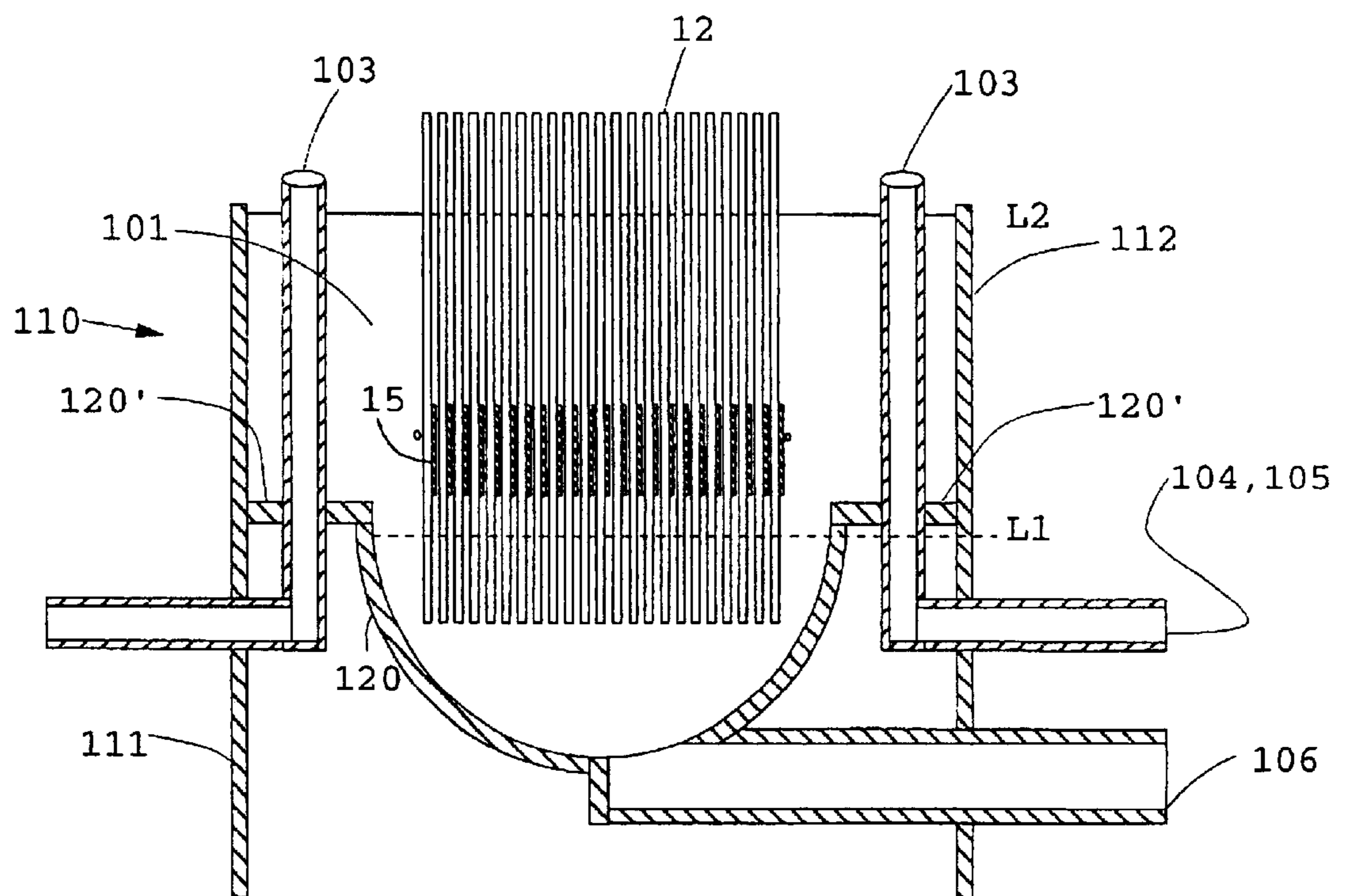

FIG. 6

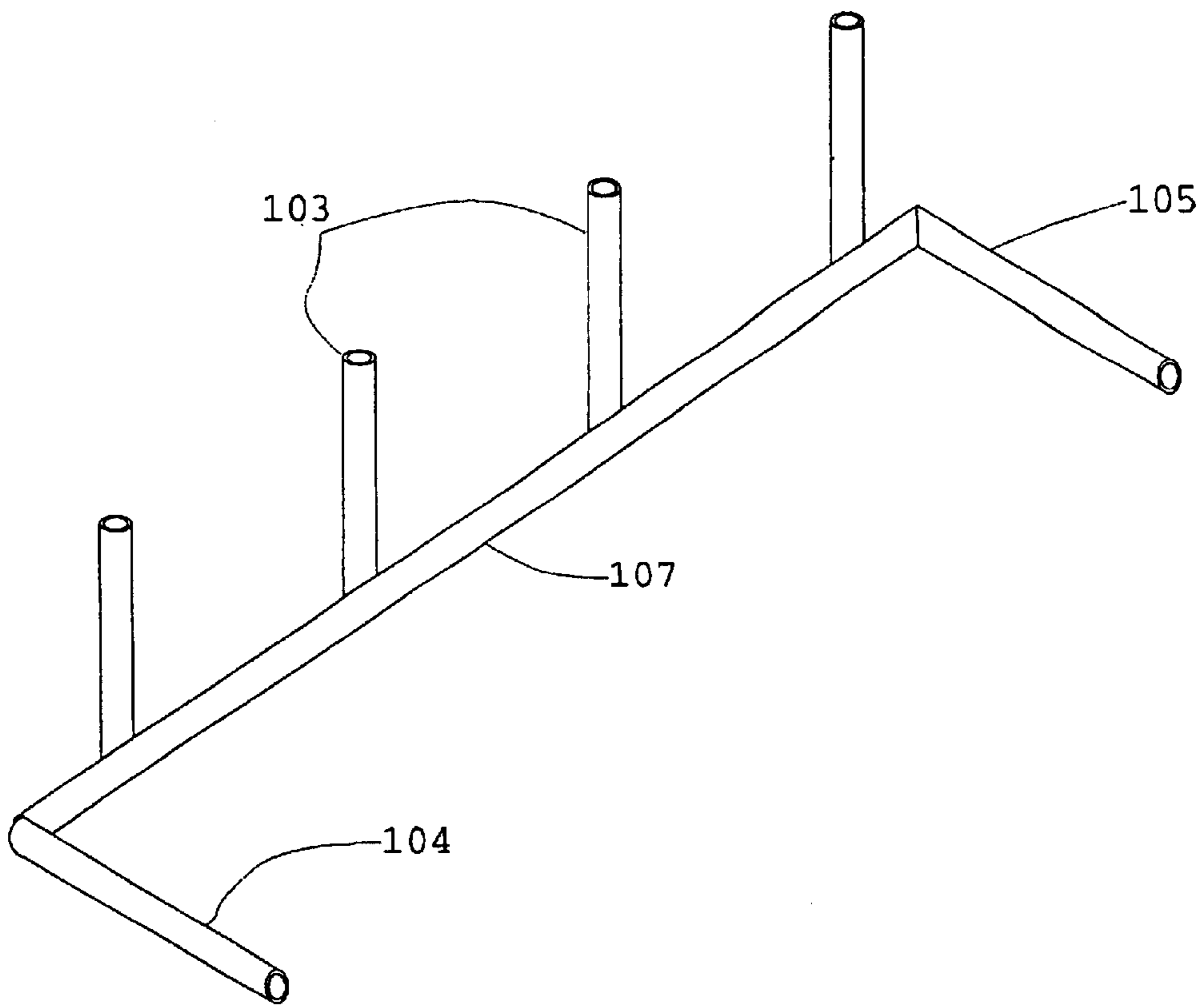

FIG. 7A

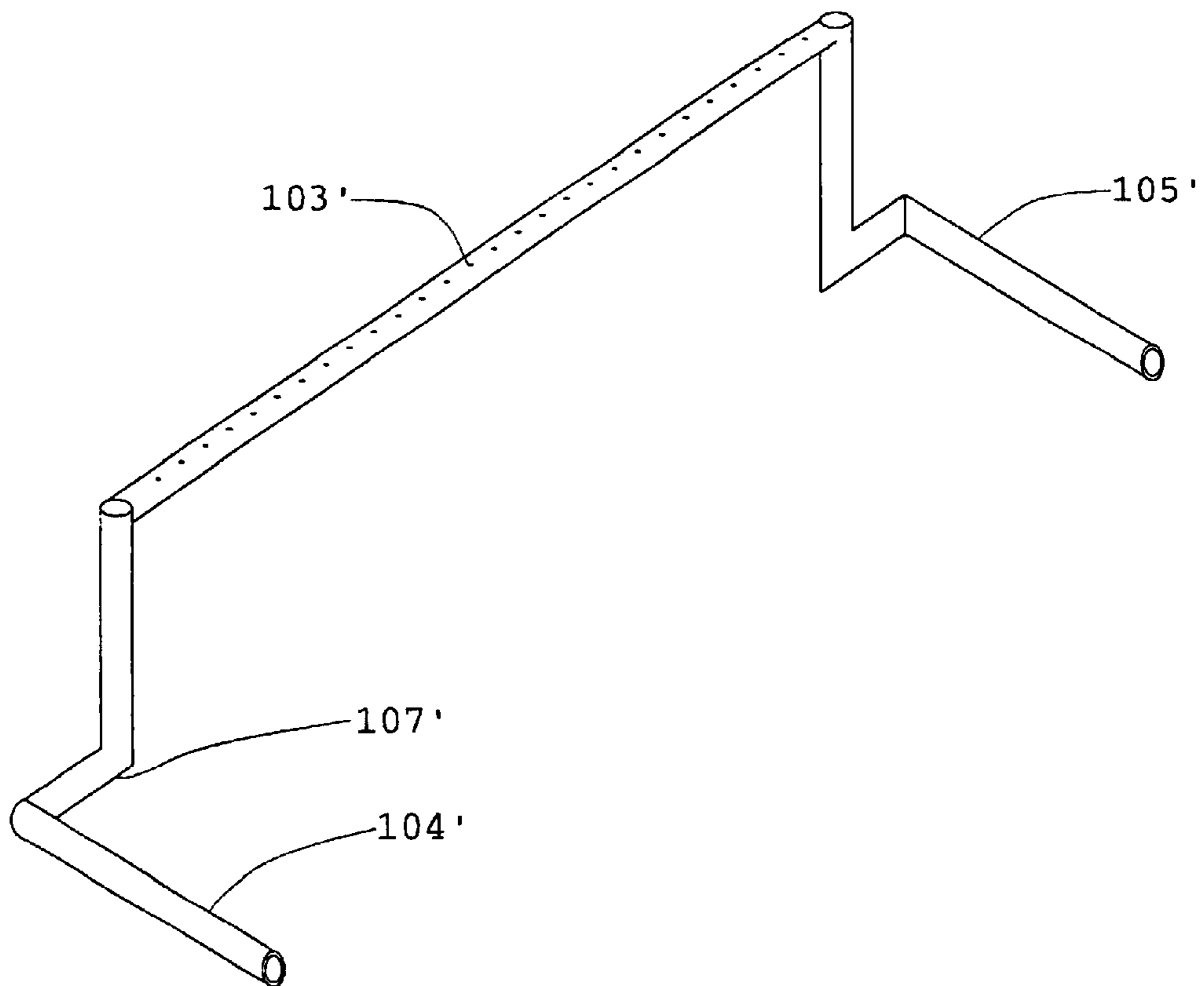

FIG. 7B

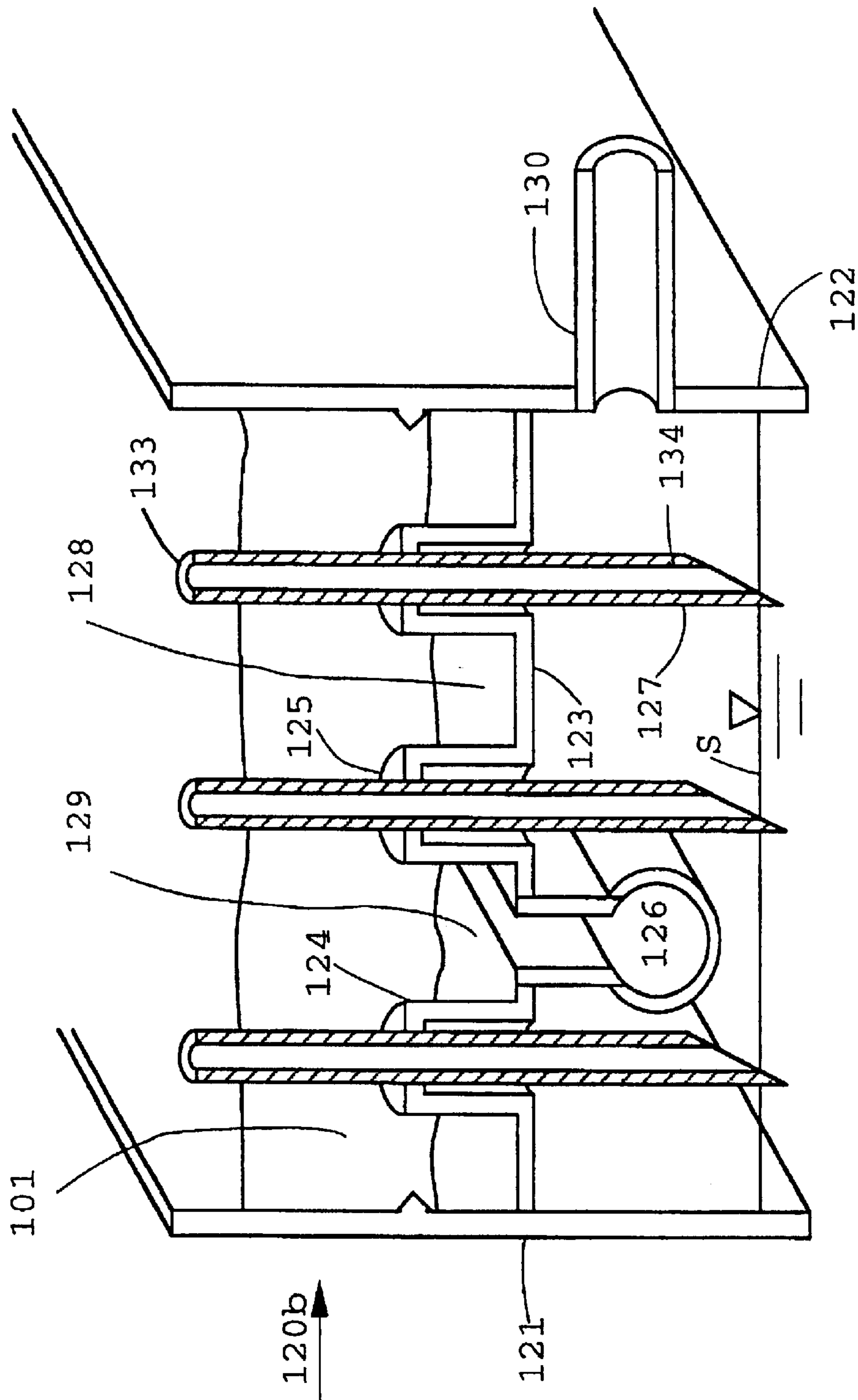
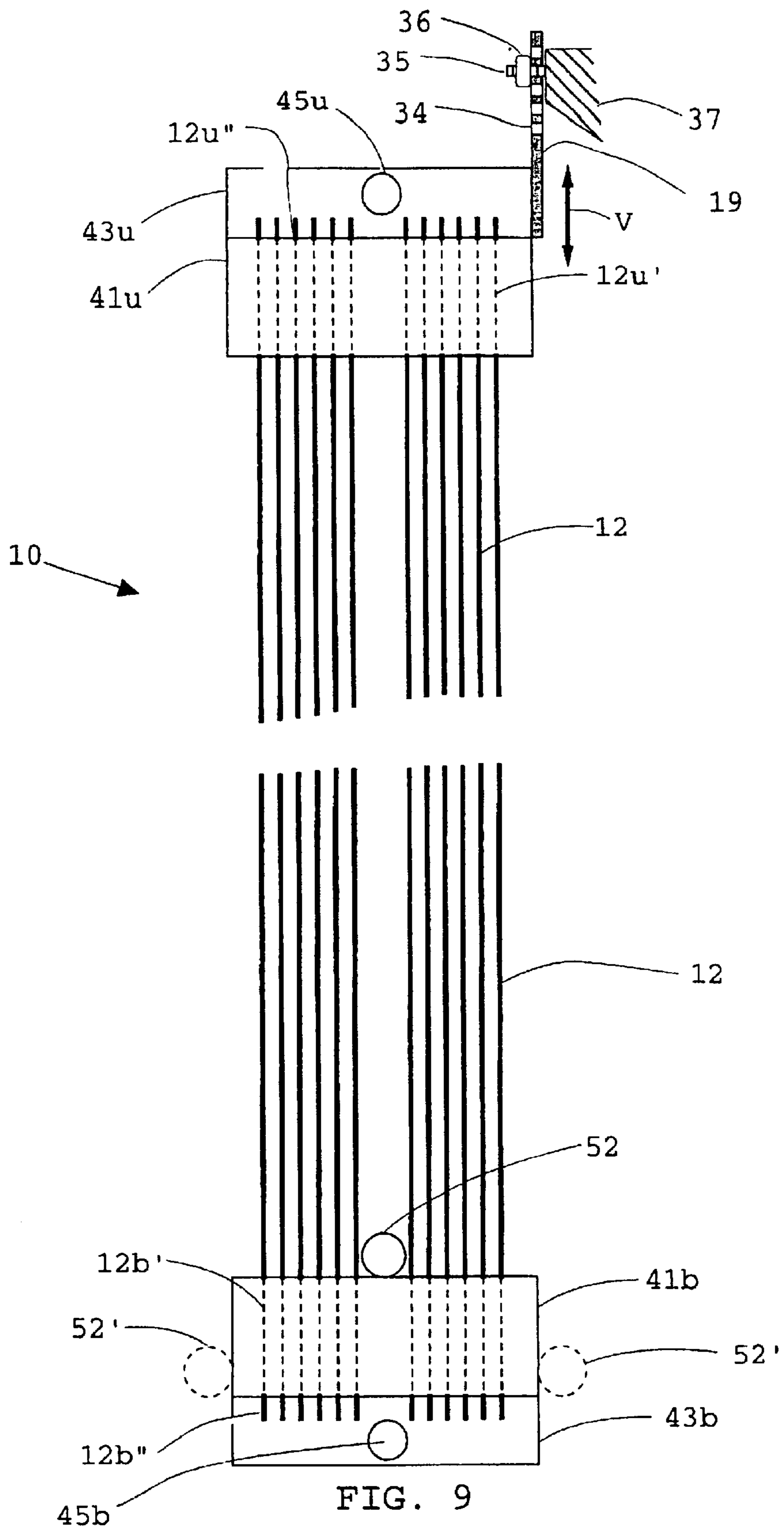

FIG. 8



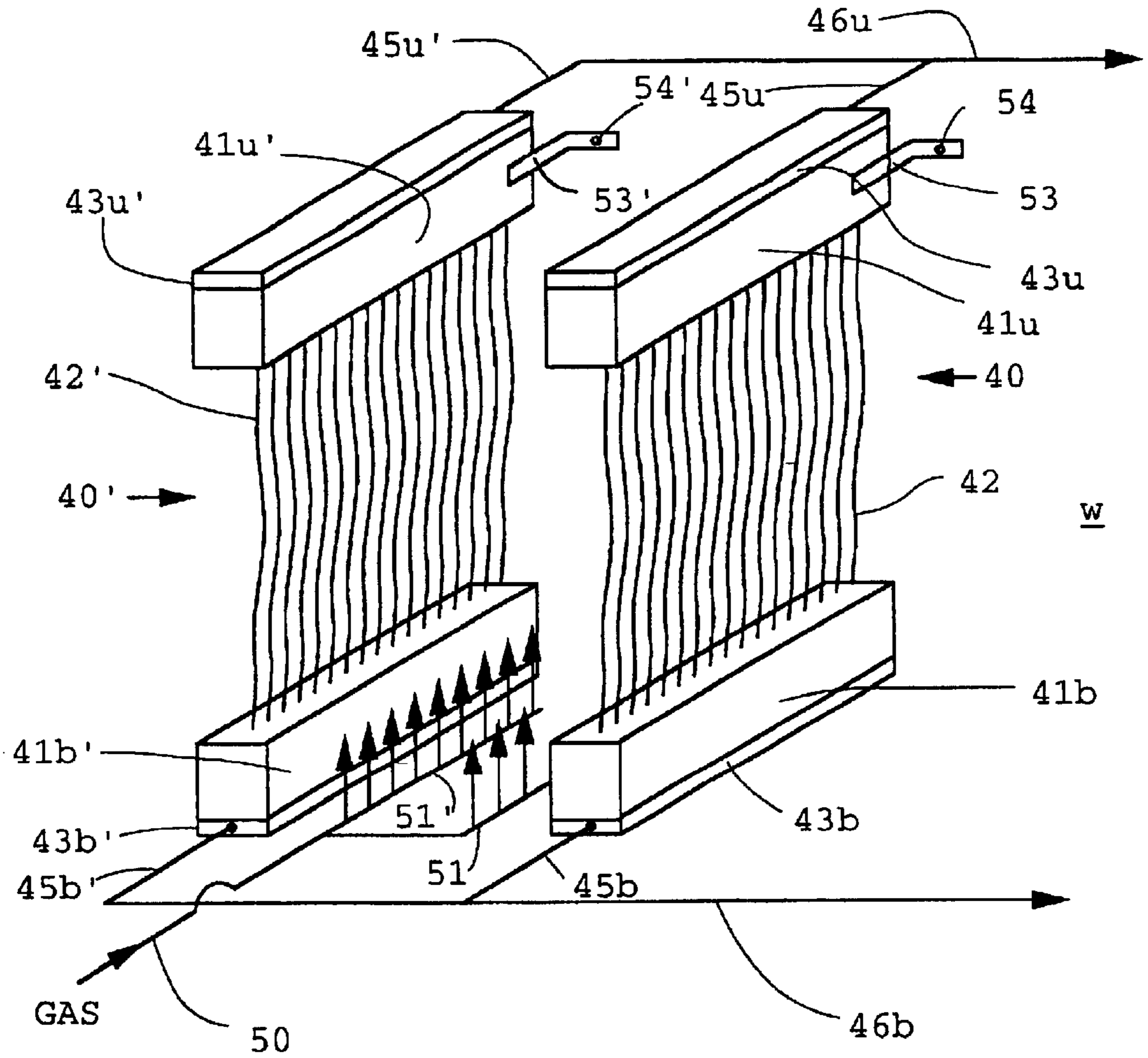

FIG. 10

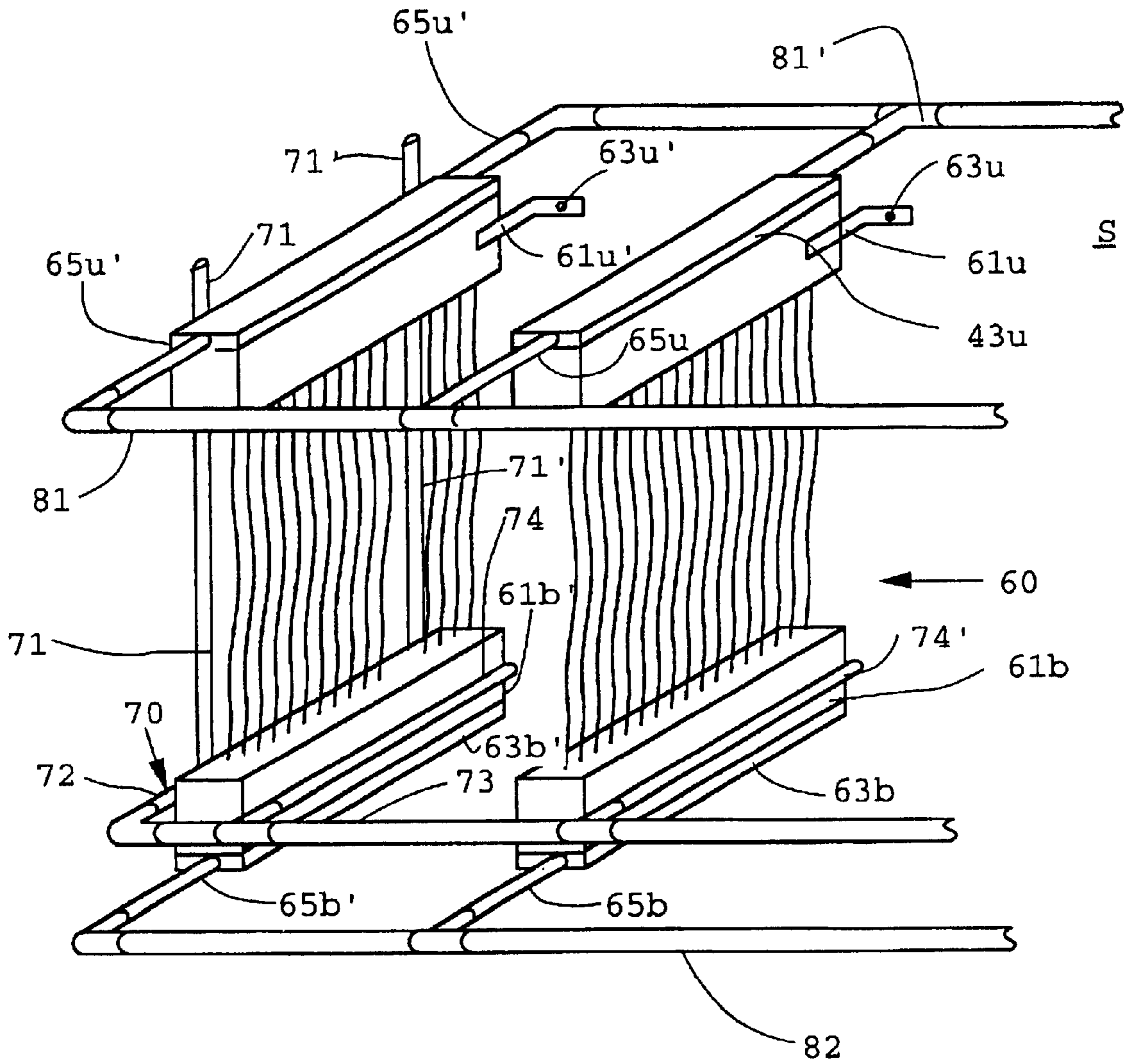

FIG. 11

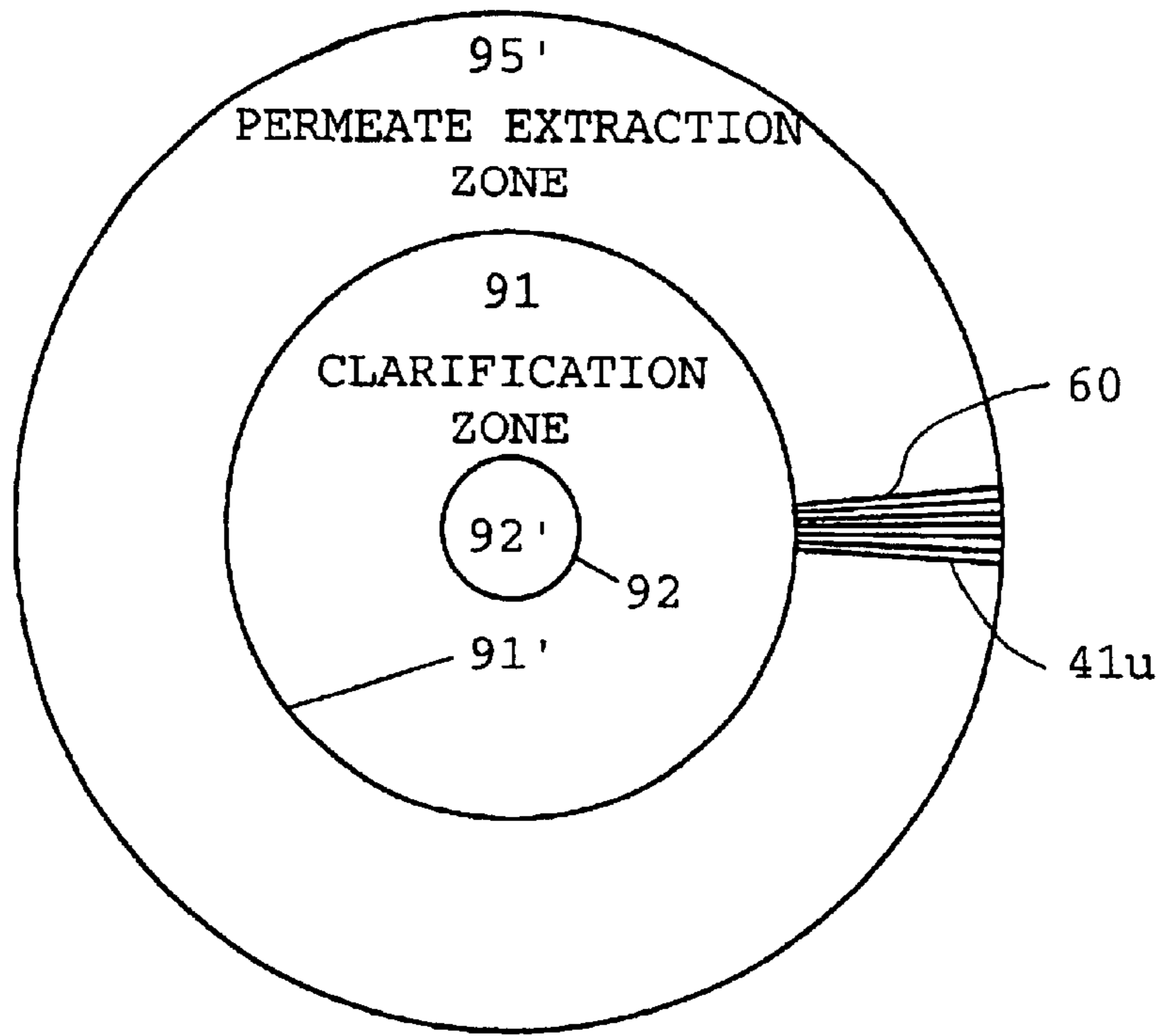
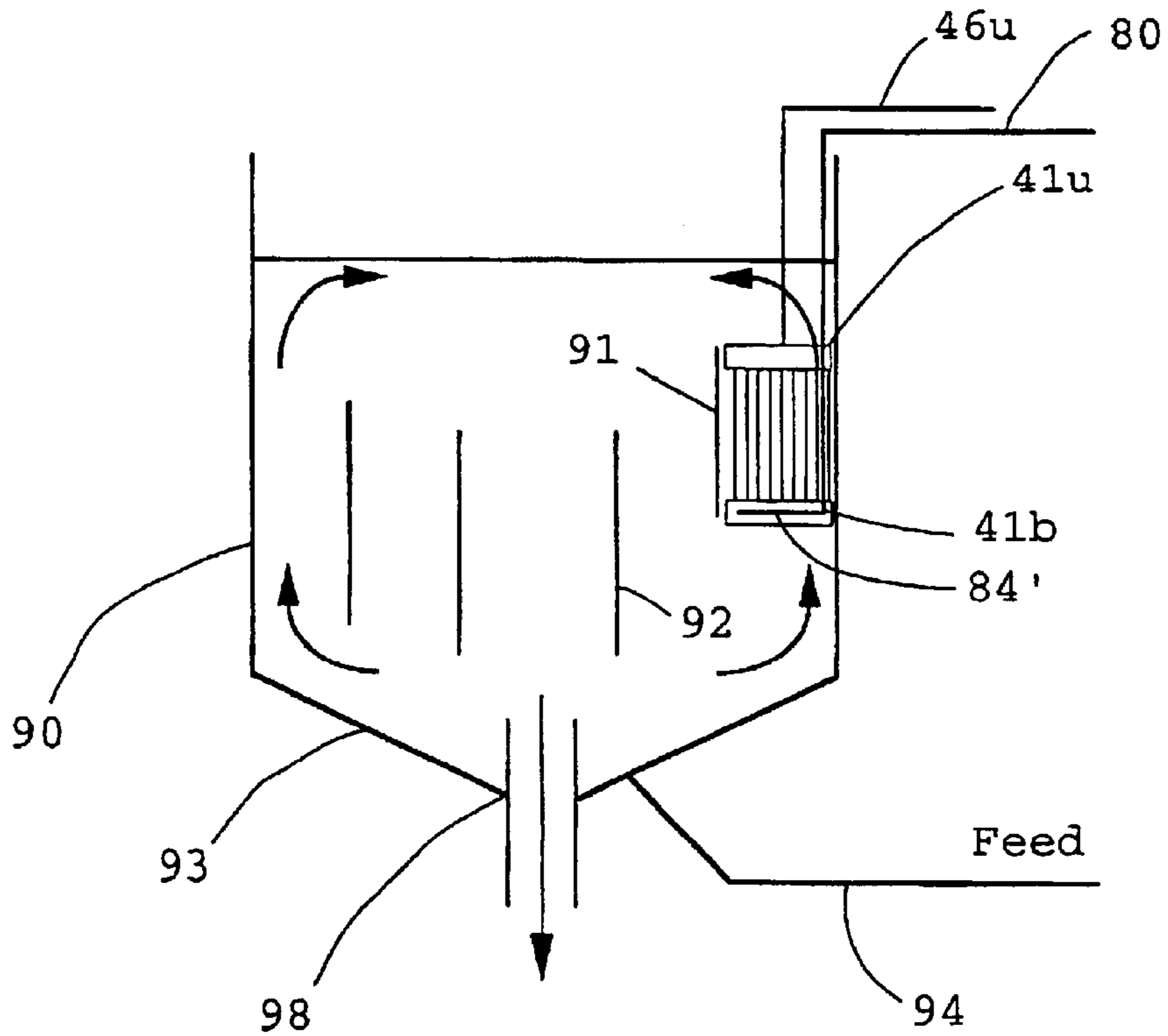

FIG. 13



SLUDGE REMOVAL

FIG. 12

**VERTICAL SKEIN OF HOLLOW FIBER
MEMBRANES AND METHOD OF
MAINTAINING CLEAN FIBER SURFACES
WHILE FILTERING A SUBSTRATE TO
WITHDRAW A PERMEATE**

Matter enclosed in heavy brackets [] appears in the original patent but forms no part of this reissue specification; matter printed in italics indicates the additions made by reissue.

BACKGROUND OF THE INVENTION

This invention relates to a membrane device which is an improvement on a frameless array of hollow fiber membranes and a method of maintaining clean fiber surfaces while filtering a substrate to withdraw a permeate, which is also the subject of U.S. Pat. No. 5,248,424; and, to a method of forming a header for a skein of fibers. The term "vertical skein" in the title (hereafter "skein" for brevity), specifically refers to an integrated combination of structural elements including (i) a multiplicity of vertical fibers of substantially equal length; (ii) a pair of headers in each of which are potted the opposed terminal portions of the fibers so as to leave their ends open; and, (iii) permeate collection means held peripherally in fluid-tight engagement with each header so as to collect permeate from the ends of the fibers.

The term "fibers" is used for brevity, to refer to "hollow fiber membranes" of porous or semipermeable material in the form of a capillary tube or hollow fiber. The term "substrate" refers to a multicomponent liquid feed. A "multicomponent liquid feed" in this art refers, for example, to fruit juices to be clarified or concentrated; wastewater or water containing particulate matter; proteinaceous liquid dairy products such as cheese whey, and the like. The term "particulate matter" is used to refer to micron-sized (from 1 to about 44 μm) and sub-micron sized (from about 0.1 μm to 1 μm) filtrable matter which includes not only particulate inorganic matter, but also dead and live biologically active microorganisms, colloidal dispersions, solutions of large organic molecules such as fulvic acid and humic acid, and oil emulsions.

The term "header" is used to specify a solid body in which one of the terminal end portions of each one of a multiplicity of fibers in the skein, is sealingly secured to preclude substrate from contaminating the permeate in the lumens of the fibers. Typically, a header is a continuous, generally rectangular parallelepiped of solid resin (thermoplastic or thermosetting) of arbitrary dimensions formed from a natural or synthetic resinous material. In the novel method described hereinbelow, the end portions of individual fibers are potted in spaced-apart relationship in cured resin, most preferably by "potting" the end portions sequentially in at least two steps, using first and second potting materials. The second potting material (referred to as "fixing material") is solidified or cured after it is deposited upon a "fugitive header" (so termed because it is removable) formed by solidifying the first liquid. Upon removing the fugitive header, what is left is the "finished" or "final" header formed by the second potting material. Of course, less preferably, any prior art method may be used for forming finished headers in which opposed terminal end portions of fibers in a stack of arrays are secured in proximately spaced-apart relationship with each other.

The '424 patent required potting the opposed ends of a frameless array of fibers and dispensed with the shell of a module; it was an improvement on two preceding configura-

rations disclosed in U.S. Pat. Nos. 5,182,019, and 5,104,535, each of which used frameless arrays and avoided potting the fibers. The efficiency of gas-scrubbing '424 array was believed to be due, at least in large part, to a substantial portion of the fibers of the fibers in the array lying in transverse relationship to a mass of rising bubbles, referred to herein as a "column of rising bubbles", so as to intercept the bubbles. Specific examples are illustrated in FIGS. 9, 9A, 10 and 11 of the '424 patent.

A '424 "array" referred to a bundle of arcuate fibers the geometry of which array was defined by the position of a pair of transversely spaced headers in which the fibers were potted. In the '424 array, as in the array of this invention, each fiber is free to move independently of the others, but the degree of movement in the '424 is unspecified and arbitrary, while in the vertical skein of this invention, movement is critically restricted by the defined length of the fibers between opposed headers. Except for their opposed ends being potted, there is no physical restraint on the fibers of a skein. To avoid confusion with the term "array" as used for the '424 bundle of arcuate fibers, the term "skein fibers" is used herein to refer to plural arrays. An "array" in this invention refers to plural, essentially vertical fibers of substantially equal lengths, the one ends of each of which fibers are closely spaced-apart, either linearly in the transverse (y-axis herein) direction to provide at least one row, and typically plural rows of equidistantly spaced apart fibers. Less preferably, a multiplicity of fibers may be spaced in a random pattern. Typically, plural arrays are potted in a header and enter its face in a generally x-y plane (see FIG. 5). The width of a rectangular parallelepiped header is measured along the x-axis, and is the relatively shorter dimension of the rectangular upper surface of the header; and, the header's length, which is its relatively longer dimension, is measured along the y-axis.

This invention is particularly directed to relatively large systems for the microfiltration of liquids, and capitalizes on the simplicity and effectiveness of a configuration which dispenses with forming a module in which the fibers are confined. As in the '424 patent, the novel configuration efficiently uses a cleansing gas, typically air, discharged near the base of a skein to produce bubbles in a specified size range, and in an amount large enough to scrub the fibers, and to cause the fibers to scrub themselves against one another. Unlike in the '424 system the fibers in a skein are vertical and do not present an arcuate configuration above a horizontal plane through the horizontal center-line of a header. As a result, the path of the rising bubbles is generally parallel to the fibers and is not crossed by the fibers of a vertical skein. Yet the bubbles scrub the fibers. The restrictedly swayable fibers, because of their defined length, do not get entangled, and do not abrade each other excessively, as is likely in the '424 array. The defined length of the fibers herein minimizes (i) shearing forces where the upper fibers are held in the upper header, (ii) excessive rotation of the upper portion of the fibers, as well as (iii) excessive abrasion between fibers. The fibers of this invention are confined so as to sway in a "zone of confinement" (or "bubble zone") through which bubbles rise along the outer surfaces of the fibers. The side-to-side displacement of an intermediate portion of each fiber within the bubble zone is restricted by the fiber's length. The bubble zone, in turn, is determined by one or more columns of vertically rising gas bubbles, preferably of air, generated near the base of a skein.

Since there is no module in the conventional sense, the main physical considerations which affect the operation of a vertical skein in a reservoir of substrate relate to intrinsic

considerations, namely, (a) the fiber chosen, (b) the amount of air used, and (c) the substrate to be filtered. Such considerations include the permeability and rejection properties of the fiber, the process flow conditions of substrate such as pressure, rate of flow across the fibers, temperature, etc., the physical and chemical properties of the substrate and its components, the relative directions of flow of the substrate (if it is flowing) and permeate, the thoroughness of contact of the substrate with the outer surfaces of the fibers, and still other parameters, each of which has a direct effect on the efficiency of the skein. The goal is to filter a slow moving or captive substrate in a large container under ambient or elevated pressure, but preferably under essentially ambient pressure, and to maximize the efficiency of a skein which does so (filters) practically and economically.

In the skein of this invention, all fibers in the plural rows of fibers, staggered or not, rise generally vertically while fixedly held near their opposed terminal portions in a pair of opposed, substantially identical headers to form the skein of substantially parallel, vertical fibers. This skein typically includes a multiplicity of fibers, the opposed ends of which are potted in closely-spaced-apart profusion and bound by potting resin, assuring a fluid-tight circumferential seal around each fiber in the header and presenting a peripheral boundary around the outermost peripheries of the outermost fibers. The position of one fiber relative to another in a skein is not critical, so long as all fibers are substantially codirectional through one face of each header, open ends of the fibers emerge from the opposed other face of each header, and substantially no terminal end portions of fibers are in fiber-to-fiber contact. We found that the skein of fibers, deployed to be restrictedly swayable, were as ruggedly durable as they were reliable in operation.

The fibers are stated to be "restrictedly swayable", because the extent to which they may sway is determined by the free length of the fibers relative to the fixedly spaced-apart headers, and the turbulence of the substrate. When a large number of fibers is used in a skein, as is typically the case herein, the movement of a fiber adjacent to others may be modulated by the movement of the others, but the movement of fibers within a skein is constricted. This system is therefore limited to the use of a skein of fibers having a critically defined length relative to the vertical distance between headers of the skein. The defined length limits the side-to-side movement of the fibers in the substrate in which they are deployed, except near the headers where there is negligible movement.

In the prior art a vertical skein of fibers in a substrate is typically avoided due to expected problems relating to channelling of the feed. However, because the fibers are restrictedly swayable in a "bubble zone" as described herebelow the fibers are substantially evenly contacted over their individual surfaces with substrate and provide filtration performance based on a maximized surface which is substantially the sum of the surface areas of a fibers in contact with the substrate. Moreover, because of the ease with which the substrate coats the surfaces of the vertical fibers in a skein, and the accessibility of those surfaces by air bubbles, the fibers may be densely arranged in a header to provide a large membrane surface of up to 1000 m² and more.

One header of a skein is displaceable in any direction relative to the other, either longitudinally (x-axis) or transversely (y-axis), only prior to the headers being vertically fixed in spaced apart parallel relationship within a reservoir, for example, by mounting one header above another, against a vertical wall of the reservoir which functions as a spacer mess. This is also true prior to spacing one header above

another with other spacer means such as bars, rods, struts, I-beams, channels, and the like, to assemble plural skeins into a "bank of skeins" ("bank" for brevity), in which bank a row of lower headers is directly beneath a row of upper headers. After assembly into a bank, a segment intermediate the potted ends of each individual fiber is displaceable along either the x- or the y-axis, because the fibers are loosely held in the skein. There is essentially no tension on each fiber because the opposed faces of the headers are spaced apart at a distance less than the length of an individual fiber.

By operating at ambient pressure, mounting the headers of the skein within a reservoir of substrate, and by allowing the fibers restricted movement within the bubble zone in a substrate, we minimize damage to the fibers. Because, a header secures at least 10, preferably from 50 to 50,000 fibers, each generally at least 0.5 m long, in a skein, it provides a high surface area for filtration of the substrate.

The fibers divide a reservoir into a "feed zone" and a withdrawal zone referred to as a "permeate zone". The feed of substrate is introduced externally (referred to as "outside-in" flow) of the fibers, and resolved into "permeate" and "concentrate" streams. The skein, or a bank of skeins of this invention is most preferably used for microfiltration with "outside-in" flow. Typically a bank is used in a relatively large reservoir having a volume in excess of 10 L (liters), preferably in excess of 1000 L, such as a flowing stream, more typically a reservoir (pond or tank). Most typically, a bank or plural banks with collection means for the permeate, are mounted in a tank under atmospheric pressure, and permeate is withdrawn from the tank.

Where a bank or plural banks of skeins are placed within a tank or bioreactor, and no liquid other than the permeate is removed the tank is referred to as a "dead end tank". Alternatively, a bank or plural banks may be placed within a bioreactor, permeate removed, and sludge disposed of; or, in a tank or clarifier used in conjunction with a bioreactor, permeate removed, and sludge disposed of.

Operation of the system relies upon positioning at least one skein, preferably a bank, close to a source of sufficient air or gas to maintain a desirable flux, and, to enable permeate to be collected from at least one header. A desirable flux is obtained, and provides the appropriate transmembrane pressure differential of the fibers under operating process conditions. "Transmembrane pressure differential" refers to the pressure difference across a membrane wall, resulting from the process conditions under which the membrane is operating.

The relationship of flux to permeability and transmembrane pressure differential is set forth by the equation:

$$J=k \Delta P$$

wherein, J=flux; k=permeability constant; ΔP =transmembrane pressure differential; and $k=1/\mu R_m$ where μ =viscosity of water and, R_m =membrane resistance,

The transmembrane pressure differential is preferably generated with a conventional non-vacuum pump if the transmembrane pressure differential is sufficiently low in the range from 0.7 kPa (0.1 psi) to 101 kPa (1 bar), provided the pump generates the requisite suction. The term "non-vacuum pump" refers to a pump which generates a net suction side pressure difference, or, net positive suction head (NPSH), adequate to provide the transmembrane pressure differential generated under the operating conditions. By "vacuum pump" we refer to one capable of generating a suction of at least 75 cm of Hg. A pump which generates minimal suction may be used if an adequate "liquid head" is

provided between the surface of the substrate and the point at which permeate is withdrawn; or, by using a pump, not a vacuum pump. A non-vacuum pump may be a centrifugal, rotary, crossflow, flow-through, or other type. Moreover, as explained in greater detail below, once the permeate flow is induced by a pump, the pump may not be necessary, the permeate continuing to flow under a "siphoning effect". Clearly, operating with fibers subjected to a transmembrane pressure differential in the range up to 101 kPa (14.7 psi), a non-vacuum pump will provide adequate service in a reservoir which is not pressurized: and, in the range from 101 kPa to about 345 kPa (50 psi), by superatmospheric pressure generated by a high liquid head, or, by a pressurized reservoir.

The fibers are not required to be subjected to a narrowly critical transmembrane pressure differential though fibers which operate under a small transmembrane pressure differential are preferred. A fiber which operates under a small transmembrane pressure differential in the range from about 0.7 kPa (0.1 psi) to about 70 kPa (10 psi) may produce permeate under gravity alone, if appropriately positioned relative to the location where the permeate is withdrawn. In the range from 3.5 kPa (0.5 psi) to about 206 kPa (30 psi) a relatively high liquid head may be provided with a pressurized vessel. The longer the fiber, which greater the area and the more the permeate.

In the specific instance where a bank is used in combination with a source of cleansing gas such as air, both to scrub the fibers and to oxygenate a mixed liquor substrate, most, if not all of the air required, is introduced either continuously or intermittently, near the base of the fibers near the lower header. The perforations through which the gas is discharged near the header are located close enough to the fibers so as to provide columns of relatively large bubbles, preferably larger than about 1 mm in nominal diameter, which codirectionally contact the fibers and flow vertically along their outer surfaces, scrubbing them. The outer periphery of the columns of bubbles define the zone of confinement in which the scrubbing force exerted by the bubbles on the fibers, keeps their surfaces sufficiently free of attached microorganisms and deposits of inanimate particles to provide a relatively high and stable flow of permeate over many weeks, if not months of operation. The significance of this improvement will be better appreciated when it is realized that the surfaces of fibers in conventional modules are cleaned nearly every day, and sometimes more often.

Because this system, like the '424 system, does away with using a shell, there is no void space within a shell to be packed with fibers; and, because of gas being introduced proximately to, and near the base of skein fibers, there is no need to maintain a high substrate velocity across the surface of the fibers to keep the surfaces of the fibers clean. As a result, there is virtually no limit to the number of restrictedly swayable fibers which may be used in a skein, the practical limit being set by (i) the ability to pot the ends of the fibers reliably; (ii) the ability to provide sufficient air to the surfaces of essentially all the fibers, and (iii) the number of banks which may be deployed in a tank, pond or lake, the number to be determined by the size of the body of water, the rate at which permeate is to be withdrawn, and, the cost of doing so.

Typically, a relatively large number of long fibers, at least 100, is used in a skein of restrictedly swayable fibers, the fibers operate under a relatively low transmembrane pressure differential, and permeate is withdrawn with a non-vacuum pump. If the liquid head, measured as the vertical distance between the level of substrate and the level from

which permeate is to be withdrawn, is greater than the transmembrane pressure differential under which the fiber operates, the permeate will be separated from the remaining substrate, due to gravity.

Irrespective of whether a non-vacuum pump, vacuum pump, or other type of pump is used, or permeate is withdrawn with a siphoning effect, it is essential that the fibers in a skein be positioned in a generally vertical attitude, rising above the lower header. An understanding of how a vertical skein operates will make it apparent that, since fibers in a skein are anchored at the base of the skein by the lower header, the specific gravity of the fibers relative to that of the substrate is immaterial and will not affect their vertical disposition.

The unique method of forming a header disclosed herein allows one to position a large number of fibers, in closely-spaced apart relationship, randomly relative to one another, or, in a chosen geometric pattern, within each header of synthetic resinous material. It is preferred to position the fibers in arrays before they are potted to ensure that the fibers are spaced apart from each other precisely, and, to avoid wasting space on the face of a header; it is essential, for greatest reliability, that the fibers not be contiguous. By sequentially potting the terminal portions of fibers in stages as described herein, the fibers may be cut to length in an array, either after, or prior to being potted. The use of a razor-sharp knife, or scissors, or other cutting means to do so, does not decrease the open cross sectional area of the fibers' bores ("lumens"). The solid resin forms a circumferential seal around the exterior terminal portions of each of the fibers, open ends of which protrude through the permeate-discharging face of each header, referred to as the "aft" face.

Further, one does not have to cope with the geometry of a frame, the specific function of which is to hold fibers in a particular arrangement within the frame. In a skein, the sole function of the header spacing means is to maintain a fixed vertical distance between headers which are not otherwise spaced apart. In a skein of this invention, there is no frame.

The skein of this invention is most preferably used to treat wastewater in combination with a source of an oxygen-containing gas which is bubbled within the substrate, near the base of a lower header, either within a skein or between adjacent skeins in a bank, for the specific purpose of scrubbing the fibers and oxygenating the mixed liquor in activated sludge, such as is generated in the bioremediation of wastewater. It was found that, as long as enough air is introduced near the base of each lower header to keep the fibers awash in bubbles, and the fibers are restrictedly swayable in the activated sludge, a build-up of growth of microbes on the surfaces of the fibers is inhibited while permeate is directly withdrawn from activated sludge, and excellent flow of permeate is maintained over a long period. Because essentially all surface portions of the fibers are contacted by successive bubbles as they rise, whether the air is supplied continuously or intermittently, the fibers are said to be "awash in bubbles."

The use of an array of fibers in the direct treatment of activated sludge in a bioreactor, is described in an article titled "Direct Solid-Liquid Separation Using Hollow Fiber Membrane in an Activated Sludge Aeration Tank" by Kazuo Yamamoto et al in *Wat. Sci. Tech.* Vol. 21, Brighton pp 43-54, 1989, and discussed in the '424 patent, the disclosure of which is incorporated by reference thereto as if fully set forth herein. The relatively poor performance obtained by Yamamoto et al was mainly due to the fact that they did not realize the critical importance of maintaining flux by aerat-

ing a skein of fibers from within and beneath the skein. They did not realize the necessity of thoroughly scrubbing substantially the entire surfaces of the fibers by flowing bubbles through the skein to keep the fibers awash in bubbles. This requirement becomes more pronounced as the number of fibers in the skein increases.

As will presently be evident, since most substrates are contaminated with micron and submicron size particulate material, both organic and inorganic, the surfaces of the fibers in any practical membrane device must be maintained in a clean condition to obtain a desirable specific flux. To do this, the most preferred use of the skein as a membrane device is in a bank, in combination with a gas-distribution means, which is typically used to distribute air, or oxygen-enriched air between the fibers, from within the skein, or between adjacent skeins, at the bases thereof.

Tests using the device of Yamamoto et al indicate that when the air is provided outside the skein the flux decreases much faster over a period of as little as 50 hr, confirming the results obtained by them. This is evident in FIG. 1 described in greater detail below, in which the graphs show results obtained by Yamamoto et al, and the '424 array, as well as those with the vertical skein, all three assemblies using essentially identical fibers, under essentially identical conditions.

The investigation of Yamamoto et al with downwardly suspended fibers was continued and recent developments were reported in an article titled "Organic Stabilization and Nitrogen Removal in Membrane Separation Bioreactor for Domestic Wastewater Treatment" by C. Chiemchaisri et al delivered in a talk to the Conference on Membrane Technology in Wastewater Management, in Cape Town, South Africa. Mar. 2-5, 1992, also discussed in the '424 patent. The fibers were suspended downwardly and highly turbulent flow of water in alternate directions, was essential.

It is evident that the disclosure in either the Yamamoto et al or the Chiemchaisri et al reference indicated that the flow of air across the surfaces of the suspended fibers did little or nothing to inhibit the attachment of microorganisms from the substrate.

SUMMARY OF THE INVENTION

It has been discovered that bubbles of a fiber-cleansing gas ("scrubbing gas") flowing parallel to fibers in a vertical skein are more effective than bubbles which are intercepted by arcuate fibers crossing the path of the rising bubbles. Bubbles of an oxygen-containing gas to promote growth of microbes unexpectedly fails to build-up growth of microbes on the surfaces of the fibers because the surfaces are "vertically air-scrubbed". Deposits of animate and/or inanimate particles upon the surfaces of fibers are minimized when the restrictedly swayable fibers are kept awash in codirectionally rising bubbles which rise with sufficient velocity to exert a physical scrubbing force (momentum provides the energy) to keep the fibers substantially free of deleterious deposits. Thus, an unexpectedly high flux is maintained over a long period during which permeate is produced by outside-in flow through the fibers.

It has also been discovered that permeate may be efficiently withdrawn from a substrate for a surprisingly long period, in a single stage, essentially continuous filtration process, by mounting a pair of headers in vertically spaced apart relationship, one above another, within the substrate which directly contacts a multiplicity of long vertical fibers in a "gas-scrubbed assembly" comprising a skein and a gas-distribution means. The skein has a surface area which is at least $>1 \text{ m}^2$, and opposed spaced-apart ends of the fibers

are secured in spaced-apart headers, so that the fibers, when deployed in the substrate, acquire a generally vertical profile therewithin and sway within the bubble zone defined by at least one column of bubbles. The length of fibers between opposed surfaces of headers from which they extend, is in a critical range from at least 0.1% (per cent) longer than the distance separating those opposed faces, but less than 5% longer. Usually the length of fibers is less than 2% longer, and most typically, less than 1% longer, so that sway of the fibers is confined within a vertical zone of movement, the periphery of which zone is defined by side-to-side movement of outer fibers in the skein; and, the majority of the fibers near the periphery move in a slightly larger zone than one defined by the projected area of one header upon the other. Though the distance between headers is fixed during operation, the distance is preferably adjustable to provide an optimum length of fibers, within the aforesaid ranges, between the headers. It has been found that for no known reason, fibers which are more than 5% but less than 10% longer than the fixed distance between the opposed faces of the headers of a skein, tend to shear off at the face; and those 10% longer tend to clump up in the bubble zone.

The terminal end portions of the fibers are secured non-contiguously in each header, that is, the surface of each fiber is sealingly separated from that of another adjacent fiber with cured potting resin. Preferably, for maximum utilization of space on a header, the fibers are deliberately set in a geometrically regular pattern. Typically permeate is withdrawn from the open ends of fibers which protrude from the permeate-discharging aft (upper) face of a header. The overall geometry of potted fibers is determined by a 'fiber-setting form' used to set individual fibers in an array. The skein operates in a substrate held in a reservoir at a pressure in the range from 1 atm to an elevated pressure up to about 10 atm in a pressurized vessel, without being confined within the shell of a module.

It is therefore a general object of this invention to provide a novel, economical and surprisingly trouble-free membrane device, for providing an alternative to both, a conventional module having plural individual arrays therewithin, and also to a frameless array of arcuate fibers; the novel device includes, (i) a vertical skein of a multiplicity of restrictedly swayable fibers, together having a surface area in the range from 1 m^2 to 1000 m^2 , preferably from 10 m^2 to 100 m^2 . secured only in spaced-apart headers; and (ii) a gas-scrubbing means which produces at least one column of bubbles engulfing the skein. A skein includes permeate pans disposed, preferably non-removably, within a substrate held in a reservoir of arbitrary proportions, the reservoir typically having a volume in excess of 100 L (liters). generally in excess of 1000 L. A fluid component is to be selectively removed from the substrate.

It is a specific object of this invention to provide a membrane device having hollow fibers for removing permeate from a substrate, comprising, a skein of a multiplicity of fibers restrictedly swayable in the substrate, the opposed terminal end portions of which fibers in spaced-apart relationship, are potted in a pair of headers, one upper and one lower, each adapted to be mounted in vertically spaced apart generally parallel relationship, one above the other, within the substrate; essentially all the ends of fibers in both headers are open so as to pass permeate through the headers; the fibers in a skein have a length in the range from at least 0.1% greater, but less than 5% greater than the direct distance between opposed faces of the upper and lower headers, so as to present the fibers, when they are deployed, in an essentially vertical configuration; permeate is collected

in a collection means, such as a permeate pan; and, permeate is withdrawn through a ducting means including one or more conduits and appropriate valves.

It has also been discovered that skein fibers are maintained sufficiently free from particulate deposits with surprisingly little cleansing gas, so that the specific flux at equilibrium is maintained over a long period, typically from 50 hr to 1500 hr, because the skein is immersed so as to present a generally vertical profile, and, the skein is maintained awash in bubbles either continuously or intermittently generated by a gas-distribution means ("air manifold"). The air-manifold is disposed adjacent the skein's lower header to generate a column of rising bubbles within which column the fibers are awash in bubbles. A bank of skeins is "gas-scrubbed" with plural air-tubes disposed between the lower headers of adjacent skeins, most preferably, also adjacent the outermost array of the first and last skeins, so that for "n" headers there are "n+1" air-manifolds. Each header is preferably in the shape of a rectangular parallelepiped, the upper and lower headers having the same transverse (y-axis) dimension, so that plural headers are longitudinally stackable (along the x-axis). Common longitudinally positioned linear air-tubes, or, individual, longitudinally spaced apart vertically rising air-tubes, service the bank, and one or more permeate tubes withdraw permeate.

It is therefore a general object of this invention to provide a gas-scrubbed assembly of fibers for liquid filtration, the assembly comprising, (a) bank of gas-scrubbed skeins of fibers which separate a desired permeate from a large body of multicomponent substrate having finely divided particulate matter in the range from 0.1 μm –44 μm dispersed therein, (b) each skein comprising at least 20 fibers having upper and lower terminal portions potted spaced-apart, in upper and lower headers, respectively, the fibers being restrictedly swayable in a bubble zone, and (c) a shaped gas distribution means adapted to provide a profusion of vertically ascending bubbles near the lower header, the length of the fibers being from at least 0.1% but less than 5% greater than the distance between the opposed faces of the headers. The gas-distribution means has through-passages therein through which gas is flowed at a flow rate which is proportional to the number of fibers. The flow rate is generally in the range from 0.47–14 cm^3/sec per fiber (0.001–0.03 scfm/fiber (standard ft^3 per minute per fiber), typically in the range from 1.4–4.2 $\text{cm}^3/\text{sec}/\text{fiber}$ (0.003–0.009 scmf/fiber). The surface area of the fibers is not used to define the amount of air used because the air travels substantially vertically along the length of each fiber. The gas generates bubbles having an average diameter in the range from about 0.1 mm to about 25 mm, or even larger.

It is a specific object of this invention to provide the aforesaid novel gas-scrubbed assembly comprising a bank of vertical skeins and a shaped gas-distribution means for use with the bank, in a substrate in which microorganisms grow, the assembly being used in combination with vertically adjustable spacer means for mounting the headers in vertically spaced apart relationship, and in open fluid communication with collection means for collecting the permeate; means for withdrawing the permeate; and, sufficient air is flowed through the shaped gas-distribution means to generate enough bubbles flowing upwardly through the skein, between and parallel to the fibers so as to keep the surfaces of the fibers substantially free from deposits of live microorganisms as well as small inanimate particles which may be present in the substrate.

It has still further been discovered that a system utilizing a bank of vertical skeins of fibers potted in headers vertically

spaced-apart by spacer means, and deployed in a substrate containing particulate material, in combination with a proximately disposed gas-distribution means to minimize fouling of the membranes, may be operated to withdraw permeate under gravity alone, so that the cost of any pump to withdraw permeate is avoided, provided the net positive suction head corresponding to the vertical height between the level of substrate, and the location of withdrawal of permeate, provides the transmembrane pressure differential under which the fibers function in the skein.

It is therefore a general object of this invention to provide the foregoing system in which opposed terminal end portions of skein fibers are essentially free from fiber-to-fiber contact after being potted in upper and lower headers kept vertically spaced-apart with spacer means, the skein being unconfined in a shell of a module and deployed in the substrate without the fibers being supported during operation except by the spacer means which support only the headers; the headers being mounted so that the fibers present a generally vertical profile yet are restrictedly swayable in a zone of confinement defined by rising bubbles; means for mounting each header in open fluid communication with collection means for collecting permeate, and, means for withdrawing the permeate; and, shaped gas-distribution means adapted to generate bubbles from micron-size to 25 mm in nominal diameter, most preferably in the size range from 1 mm to 20 mm, the bubbles flowing upwardly through and parallel to the fibers at a flow rate chosen from the range specified hereabove; whereby the fibers are scrubbed with bubbles and resist the attachment of growing microorganisms and any other particulate matter to the surfaces of the fibers, so as to maintain a desirable specific flux during operation.

Still further, a low cost process has been discovered for treating a multicomponent substrate under pressure ranging from 1–10 atm in a pressurizable vessel, particularly for example, an aqueous stream containing finely divided inorganic matter such as silica, silicic acid, or, activated sludge, when the substrate is confined in a large tank or pond, by using a bank of vertical skeins each comprising restrictedly swayable unsupported fibers potted in headers in open fluid communication with a means for withdrawing permeate, in combination with a source of air which generates bubbles near the lower header.

It is therefore a general object of this invention to provide a process for maintaining relatively clean fiber surfaces in an array of a membrane device while separating a permeate from a substrate, the process comprising, submerging a skein of restrictedly swayable substantially vertical fibers within the substrate so that upper and lower headers of the skein are mounted one above the other with a multiplicity of fibers secured between said headers, the fibers having their opposed terminal portions in open fluid communication with permeate collecting means in fluid-tight connection with said headers; the fibers operating under a transmembrane pressure differential in the range from about 0.7 kPa (0.1 psi) to about 345 kPa (50 psi), and a length from at least 0.1% to about 2% greater than the direct distance between the opposed faces of upper and lower headers, so as to present, when the fibers are deployed, a generally vertical skein of fibers;

maintaining an essentially constant flux substantially the same as the equilibrium flux initially obtained, indicating that the surfaces of the fibers are substantially free from further build-up of deposits once the equilibrium flux is attained;

collecting the permeate; and,
withdrawing the permeate.

It has still further been discovered that the foregoing process may be used in the operation of an anaerobic or aerobic biological reactor which has been retrofitted with the membrane device of this invention. The anaerobic reactor is a closed vessel and the scrubbing gas is a molecular oxygen-free gas, such as nitrogen.

It is therefore a general object of this invention to provide an aerobic biological reactor retrofitted with at least one gas scrubbed bank of vertical skeins, each skein made with from 500 to 5000 fibers in the range from 1 m to 3 m long, in combination with a permeate collection means, and to provide a process for the reactor's operation without being encumbered by the numerous restrictions and limitations imposed by a secondary clarification system.

A novel composite header is provided for a bundle of hollow fiber membranes or "fibers", the composite header comprising a molded, laminated body of arbitrary shape, having an upper lamina formed from a "fixing" (potting) material which is laminated to a lower lamina formed from a "fugitive" potting material. The terminal portions of the fibers are potted in the fugitive potting material when it is liquid, preferably forming a generally rectangular parallel-piped in which the open ends of the fibers (until potted) are embedded and plugged, keeping the fibers in closely spaced-apart substantially parallel relationship. The plugged ends of the fibers fail to protrude through the lower (aft) face of the lower lamina, while the remaining lengths of the fibers extend through the upper face of the lower lamina. The upper lamina extends for a height along the length of the fibers sufficient to maintain the fibers in the same spaced-apart relationship relative to one and another as their spaced-apart relationship in the lower portion. If desired, the composite header may include additional lamina, for example, a "cushioning" lamina overlying the fixing lamina, to cushion each fiber around its embedded outer circumference; and, a "gasketing" lamina to provide a suitable gasketing material against which the permeate collection means may be mounted.

BRIEF DESCRIPTION OF THE DRAWINGS

The foregoing and additional objects and advantages of the invention will best be understood by reference to the following detailed description, accompanied by schematic illustrations of preferred embodiments of the invention, in which illustrations like reference numerals refer to like elements, and in which:

FIG. 1 is a graph in which the variation of flux is plotted as a function of time, showing three curves for three runs made with three different arrays, in each case, using the same amount of air, the identical membranes and the same membrane surface area. The results obtained by Yamamoto et al are plotted as curve 2 (under conditions modified to give them the benefit of doubt as to the experimental procedure employed, as explained, below); the flux obtained using the gas-scrubbed assembly of the '424 patent is shown as curve 1; and the flux obtained using the gas scrubbed assembly of this invention is shown as curve 3.

FIG. 2 is a perspective exploded view schematically illustrating a membrane device comprising a skein of fibers, unsupported during operation of the device, with the ends of

the fibers potted in a lower header, along with a permeate collection pan, and a permeate withdrawal conduit. By "unsupported" is meant 'not supported except for spacer means to space the headers'.

FIG. 2A is an enlarged detail side elevational view of a side wall of a collection pan showing the profile of a header retaining step atop the periphery of the pan.

FIG. 2B is a bottom plan view of the header showing a random pattern of open ends protruding from the aft face of a header when fibers are potted after they are stacked in rows and glued together before being potted.

FIG. 3 is a perspective view of a single array, schematically illustrated, of a row of substantially coplanarly disposed parallel fibers secured near their opposed terminal ends between spaced apart cards. Typically, multiple arrays are assembled before being sequentially potted.

FIG. 4 illustrates a side elevational view of a stack of arrays near one end where it is clamped together, showing that the individual fibers (only the last fiber of each linear array is visible, the remaining fibers in the array being directly behind the last fiber) of each array are separated by the thickness of a strip with adhesive on it, as the stack is held vertically in potting liquid.

FIG. 5 is a perspective view schematically illustrating a skein with its integral finished header, its permeate collection pan, and twin air-tubes feeding an integral air distribution manifold potted in the header along an outer edge of the skein fibers.

FIG. 6 is a side elevational view of an integral finished header showing details of a permeate pan submerged in substrate, the walls of the header resting on the bottom of a reservoir, and multiple air-tubes feeding integral air distribution manifolds potted in the header along each outer edge of the skein fibers.

FIG. 7A is a perspective view schematically illustrating an air-manifold from which vertical air-tubes rise.

FIG. 7B is a perspective view schematically illustrating a tubular air-manifold having a transverse perforated portion, positioned by opposed terminal portions.

FIG. 8 is a perspective view of an integral finished header having plural skeins potted in a common header molded in an integral permeate collection means with air-tubes rising vertically through the header between adjacent skeins, and along the outer peripheries of the outer skeins.

FIG. 9 is a detail, not to scale, illustratively showing a gas distribution means discharging gas between arrays in a header, and optionally along the sides of the lower header.

FIG. 10 is a perspective view schematically illustrating a pair of skeins in a bank in which the upper headers are mounted by their ends on the vertical wall of a tank. The skeins in combination with a gas-distribution means form a "gas-scrubbing assembly" deployed within a substrate, with the fibers suspended essentially vertically in the substrate. Positioning the gas-distribution means between the lower headers (and optionally, on the outside of skein fibers) generate masses (or "columns") of bubbles which rise vertically, codirectionally with the fibers, yet the bubbles scrub the outer surfaces of the fibers.

FIG. 11 is a perspective view of another embodiment of the scrubbing-assembly showing plural skeins (only a pair is shown) connected in a bank with gas-distribution means disposed between successive skeins, and, optionally, with additional gas-distribution means fore and aft the first and last skeins, respectively.

FIG. 12 is an elevational view schematically illustrating a bank of skeins mounted against the wall of a bioreactor,

showing the convenience of having all piping connections outside the liquid.

FIG. 13 is a plan view of the bioreactor shown in FIG. 12 showing how multiple banks of skeins may be positioned around the circumference of the bioreactor to form a large permeate extraction zone while a clarification zone is formed in the central portion with the help of baffles.

DETAILED DESCRIPTION OF PREFERRED EMBODIMENTS

The skein of this invention may be used in a liquid-liquid separation process of choice, and more generally, in various separation processes. The skein is specifically adapted for use in microfiltration processes used to remove large organic molecules, emulsified organic liquids and colloidal or suspended solids, usually from water. Typical applications are (i) in a membrane bioreactor, to produce permeate as purified water and recycle biomass; for (ii) tertiary filtration of wastewater to remove suspended solids and pathogenic bacteria; (iii) clarification of aqueous streams including filtration of surface water to produce drinking water (removal of colloids, long chain carboxylic acids and pathogens); (iv) separation of a permeable liquid component in biotechnology broths; (v) dewatering of metal hydroxide sludges; and, (vi) filtration of oily wastewater, inter alia.

The problem with using a conventional membrane module to selectively separate one fluid from another, particularly using the module in combination with a bioreactor, and the attendant costs of operating such a system, have been avoided. In those instances where an under-developed country or distressed community lacks the resources to provide membrane modules, the most preferred embodiment of this invention is adapted for use without any pumps. In those instances where a pump is conveniently used, a vacuum pump is unnecessary, adequate driving force being provided by a simple centrifugal pump incapable of inducing a vacuum of 75 cm Hg on the suction side.

The fibers used to form the skein may be formed of any conventional membrane material provided the fibers are flexible and have an average pore cross sectional diameter for microfiltration, namely in the range from about 1000 Å to 10000 Å. Preferred fibers operate with a transmembrane pressure differential in the range from 7 kPa (1 psi)–69 kPa (10 psi) and are used under ambient pressure with the permeate withdrawn under gravity. The fibers are chosen with a view to perform their desired function, and the dimensions of the skein are determined by the geometry of the headers and length of the fibers. It is unnecessary to confine a skein in a modular shell, and a skein is not.

Preferred fibers are made of organic polymers and ceramics, whether isotropic, or anisotropic, with a thin layer or "skin" on the outside surface of the fibers. Some fibers may be made from braided cotton covered with a porous natural rubber latex or a water-insoluble cellulosic polymeric material. Preferred organic polymers for fibers are polysulfones, poly(styrenes), including styrene-containing copolymers such as acrylonitrile-styrene, butadiene styrene and styrene-vinylbenzylhalide copolymers, polycarbonates, cellulosic polymers, polypropylene, poly(vinyl chloride), poly(ethylene terephthalate), and the like disclosed in U.S. Pat. No. 4,230,463 the disclosure of which is incorporated by reference thereto as if fully set forth herein. Preferred ceramic fibers are made from alumina, by E.I. dupont deNemours Co, and disclosed in U.S. Pat. No. 4,069,157.

Typically there is no cross flow of substrate across the surface of the fibers in a "dead end" tank. If there is any flow

of substrate through the skein in a dead end tank, the flow is due to aeration provided beneath the skein, or to such mechanical mixing as may be employed to maintain the solids in suspension. There is more flow through the skein in a tank into which substrate is being continuously flowed, but the velocity of fluid across the fibers is generally too insignificant to deter growing microorganisms from attaching themselves, or suspended particles, e.g, microscopic siliceous particles, from being deposited on the surfaces of the fibers.

For hollow fiber membranes, the outside diameter of a fiber is at least 20 μm and may be as large as about 3 mm, typically being in the range from about 0.1 mm to 2 mm. The larger the outside diameter the less desirable the ratio of surface area per unit volume of fiber. The wall thickness of a fiber is at least 5 μm and may be as much as 1.2 mm, typically being in the range from about 15% to about 60% of the outside diameter of the fiber, most preferably from 0.5 mm to 12 mm.

As in a '424 array, but unlike in a conventional module, the length of a fiber in a skein is essentially independent of the strength of the fiber, or its diameter, because the skein is buoyed both by bubbles and the substrate in which it is deployed. The length of fibers in the skein is preferably determined by the conditions under which the skein is to operate. Typically fibers range from 1 m to about 5 m long, depending upon the dimensions of the body of substrate (depth and width) in which the skein is deployed.

The fixing material to fix the fibers in a finished header is most preferably either a thermosetting or thermoplastic synthetic resinous material, optionally reinforced with glass fibers, boron or graphite fibers and the like. Thermoplastic materials may be crystalline, such as polyolefins, polyamides (nylon), polycarbonates and the like, semi-crystalline such as polyetherether ketone (PEEK), or substantially amorphous, such as poly(vinyl chloride) (PVC), polyurethane and the like. Thermosetting resins commonly include polyesters, polyacetals, polyethers, cast acrylates, thermosetting polyurethanes and epoxy resins. Most preferred as a "fixing" material (so termed because it fixes the locations of the fibers relative to each other) is one which when cured is substantially rigid in a thickness of about 2 cm, and referred to generically as a "plastic" because of its hardness. Such a plastic has a hardness in the range from about Shore D 50 to Rockwell R 110 and is selected from the group consisting of epoxy resins, phenolics, acrylics, polycarbonate, nylon, polystyrene, polypropylene and ultra-high molecular weight polyethylene (UHMW PE). Polyurethane such as is commercially available under the brand names Adiprene® from Uniroyal Chemical Company and Airthane® from Air Products, and commercially available epoxy resins such as Epon 828 are excellent fixing materials.

The number of fibers in an array is arbitrary, typically being in the range from about 1000 to about 10000 for commercial applications, and the preferred surface area for a skein is in the range from 10 m² to 100 m².

The particular method of securing the fibers in each of the headers is not narrowly critical, the choice depending upon the materials of the header and the fiber, and the cost of using a method other than potting. However, it is essential that each of the fibers be secured in fluid-tight relationship within each header to avoid contamination of permeate. This is effected by potting the fibers essentially vertically, in closely-spaced relationship, either linearly in plural equally spaced apart rows across the face of a header in the x-y plane; or alternatively, randomly, in non-linear plural rows.

In the latter, the fibers are displaced relative to one another in the lateral direction.

FIG. 1 presents the results of a comparison of three runs made, one using the teachings of Yamamoto in his '89 publication (curve 2), but using an aerator which introduced air from the side and directed it radially inwards, as is shown in Chiemehaisri et al. A second run (curve 1) uses the gas-scrubbed assembly of the '424 patent, and the third run (curve 3) uses the gas-scrubbed skein of this invention. The specific flux obtained with an assembly of an inverted parabolic array with an air distributor means (Yamamoto et al). as disclosed in Wat. Sci. Tech. Vol. 21. Brighton pp 43-54, 1989, and, the parabolic array by Cote et al in the '424 patent, are compared to the specific flu obtained with the vertical skein of this invention.

The comparison is for the three assemblies having fibers with nominal pore size $0.2 \mu\text{m}$ with essentially identical bores and surface area in 80 L tanks filled with the same activated sludge substrate. The differences between the stated experiment of Yamamoto et al, and that of the '424 patent are of record in the '424 patent, and the conditions of the comparison are incorporated by reference thereto as if fully set forth herein. The vertical skein used herein differs from the '424 skein only in the vertical configuration of the 280 fibers each of which was about 1% longer than the distance between the spaced apart headers during operation. The flow rate of air for the vertical skein is $1.4 \text{ m}^3/\text{hr}/\text{m}^2$ using a coarse bubble diffuser.

It will be evident from FIG. 1 in which the specific flux, liters/meter² hr/kPa (conventionally written as (lmh/kPa), is plotted as a function of operating time for the three assemblies, that the curve, identified as reference numeral 3 for the flux for the vertical skein, provides about the same specific flu as the parabolic skein, identified as reference numeral 1. As can be seen, each specific flu reaches an equilibrium condition within less than 50 hr, but after about 250 hr, it is seen that the specific flux for the inverted parabolic array keeps declining but the other two assemblies reach an equilibrium.

Referring to FIG. 2 there is illustrated, in exploded view a portion of a membrane device referred to as a "vertical skein" 10, comprising a lower header 11 of a pair of headers, the other upper header (not shown) being substantially identical; a collection pan 20 to collect the permeate; and, a permeate withdrawal conduit 30. The header shown is a rectangular prism since this is the most convenient shape to make. If one is going to pot fibers 12 in a potting resin such as a polyurethane or an epoxy. Through the fibers 12 are not shown as close together as they would normally be, it is essential that the fibers are not in contact with each other but that they be spaced apart by the cured resin between them.

As illustrated, the open ends of the terminal portions 12' of the fibers are in the same plane as the lower face of the header 11 because the fibers are conventionally potted and the header sectioned to expose the open ends. A specific potting procedure in which the trough of a U-shaped bundle of fibers is potted, results in forming two headers. This procedure is described in the '424 patent (col 17, lines 44-61); however, even cutting the potted fibers with a thin, high speed diamond blade, tends to damage the fibers and initiate the collapse of the circumferential wall. In another conventional method of potting fibers, described in U.S. Pat. No. 5,202,023, bundled fibers have their ends dipped in resin or paint to prevent potting resin penetration into the bores of the fibers during the potting process. The ends of the bundle are then placed in molds and uncured resin added to saturate

the ends of the fiber bundle and fill the spaces between the individual fibers in the bundle and the flexible tubing in which the bundle is held. The cured molded ends are removed from the molds and the molded ends cut off (see, bridging cols 11 and 12). In each prior art method, sectioning the mold damages the embedded fibers.

Therefore a novel method is used to form, a header 11 in the form of a rectangular prism. The method requires forming a composite header with two liquids. A first liquid fugitive material, when solidified (cured). forms a "fugitive lamina" of the composite header; a second liquid of non-fugitive fixing material forms a "fixing lamina". By a "fugitive material" we refer to a material which is either (i) soluble in a medium in which the fibers and fixing material are not soluble, or (ii) fluidizable by virtue of having a melting point (if the material is crystalline) below that which might damage the fibers or fixing material; or, the material has a glass transition temperature T_g (if the material is non-crystalline), below that which might damage the fibers or material(s) forming the non-fugitive header; or (iii) both soluble and fluidizable.

The first liquid is poured around terminal portions of fibers, allowed to cool and solidify into a fugitive lamina; the fibers in the fugitive lamina are then again potted, this time by pouring the second liquid over the solid fugitive lamina.

In greater detail, the method for forming a finished header for skein fibers comprises, forming a stack of at least two superimposed essentially coplanar and similar arrays, each array comprising a chosen number of fibers supported on a support means having a thickness corresponding to a desired lateral spacing between adjacent arrays;

holding the stack in a first liquid with terminal portions of the fibers submerged, until the liquid solidifies into a first shaped lamina, provided that the first liquid is unreactive with material of the fibers;

pouring a second liquid over the first shaped lamina to embed the fibers to a desired depth, and solidifying the second liquid to form a fixing lamina upon the first shaped lamina, the second liquid also being substantially unreactive with either the material of the fibers or that of the first shaped lamina;

whereby a composite header is formed in which terminal portions of the fibers are potted, preferably in a geometrically regular pattern, the composite header comprising a laminate of a fugitive lamina of fugitive material and a contiguous finished header of fixing lamina; and thereafter,

removing the first shaped lamina without removing a portion of the fixing lamina so as to leave the ends of the fibers open and protruding from the aft face of the header, the open ends having a circular cross-section.

The step-wise procedure for forming an array "A" with the novel header is described with respect to an array illustrated in FIG. 3, as follows:

A desired number of fibers 12 are each cut to about the same length with a sharp blade so as to leave both opposed ends of each fiber with an essentially circular cross-section. The fibers are coplanarly disposed side-by-side in a linear array on a planar support means such as strips or cards 15 and 16. Preferably the strips are coated with an adhesive, e.g. a commercially available polyethylene hot-melt adhesive, so that the fibers are glued to the strips and opposed terminal portions 12' respectively of the fibers, extend beyond the strips. Intermediate portions 12' of the fibers are thus secured on the strips. Alternatively the strips may be grooved with parallel spaced-apart grooves which snugly accommodate the fibers. The strips may be flexible or rigid. If flexible,

strips with fibers adhered thereto, are in turn, also adhered to each other successively so as to form a progressively stiffer stack for a header having a desired geometry of potted fibers. To avoid gluing the strips, a regular pattern of linear rows may be obtained by securing multiple arrays on rigid strips in a stack, with rubber bands **18** or other clamping means. The terminal portions **12"** are thus held in spaced-apart relationship, with the center to center distance of adjacent fibers preferably in the range from 1.2 (1.2 d) to about 5 times (5 d) the outside diameter meter 'd' of a fiber. Spacing the fibers further apart wastes space and spacing them closer increases the risk of fiber-to-fiber contact near the terminal end portions when the ends are potted. Preferred center-to-center spacing is from about 1.5 d to 2 d. The thickness of a strip and/or adhesive is sufficient to ensure that the fibers are kept spaced apart. Preferably, the thickness is about the same as, or relatively smaller than the outside diameter of a fiber, preferably from about 0.5 d to 1 d thick, which becomes the spacing between adjacent outside surfaces of fibers in successive linear arrays.

Having formed a first array, a second array (not shown because it would appear essentially identical to the first) is prepared in a manner analogous to the first, strip **15** of the second array is overlaid upon the intermediate portions **12'** on strip **15** of the first array, the strip **15** of the second array resting on the upper surfaces of the fibers secured in strip **15** of the first array. Similarly, strip **16** of the second array is overlaid upon the intermediate portions **12'** on strip **16** of the first array.

A third array (essentially identical to the first and second) is prepared in a manner analogous to the first, and then overlaid upon the second, with the strips of the third array resting on the upper surfaces of the fibers of the second array.

Additional arrays are overlaid until the desired number of arrays are stacked in rows forming a stack of arrays with the adhesive-coated strips forming the spacing means between successive rows of fibers. The stack of arrays on strips is then held vertically to present the lower portion of the stack to be potted first.

Referring to FIG. 4, there is schematically illustrated a rectangular potting pan **17** the length and width dimensions of which correspond substantially to the longitudinal (x-axis) and transverse (y-axis) dimensions respectively, of the desired header. The lower stack is submerged in a first liquid which rises to a level indicated by L1, in the pan **17**. Most preferred is a liquid wax, preferably a water-soluble wax having a melting point lower than 75° C., such as a polyethylene glycol (PEG) wax.

The depth to which the first liquid is poured will depend upon whether the strips **15** are to be removed from, or left in the finished header.

A. First illustrated is the potting of skein fibers in upper and lower headers from which the strips will be removed.

(1) A first shaped lamina having a thickness L1 (corresponding to the depth to which the first liquid was poured) is formed to provide a fugitive lamina from about 5–10 cm thick. The depth of the first liquid is sufficient to ensure that both the intermediate portions **12'** on the strips and terminal portions **12"** will be held spaced apart when the first liquid solidifies and plugs all the fibers.

(2) The second liquid, a curable, water-insoluble liquid potting resin, or reactive components thereof, is poured over the surface of the fugitive lamina to surround the fibers, until the second liquid rises to a level L2. It is solidified to form the fixing lamina (which will be the finished header) having a thickness measured from the level L1 to the level L2 (the

thickness is written "L1-L2"). The thickness L1-L2 of the fixing lamina, typically from about 1 cm to about 5 cm, is sufficient to maintain the relative positions of the vertical fibers. A first composite header is thus formed having the combined thicknesses of the fugitive and fixing laminae.

(3) In a manner analogous to that described immediately hereinabove, a stack is potted in a second composite header.

(4) The composite headers are demolded from their potting pans and hot air blown over them to melt the fugitive laminae, leaving only the finished headers, each having a thickness L1-L2. The fugitive material such as the PEG wax, is then reused. Alternatively, a water-soluble fugitive material may be placed in hot water to dissolve the wax, and the material recovered from its water solution.

(5) The adhered strips and terminal portions of the fibers which were embedded within the fugitive lamina are left protruding from the permeate-discharging aft faces of the headers with the ends of the fibers being not only open, but essentially circular in cross section. The fibers may now be cut above the strips to discard them and the terminal portions of the fibers adhered to them, yet maintaining the circular open ends. The packing density of fibers, that is, the number of fibers per unit area of header preferably ranges from 4 to 50 fibers/cm² depending upon the diameters of the fibers.

B. Illustrated second is the potting of skein fibers in upper and lower headers from which the strips will not be removed, to avoid the step of cutting the fibers.

(1) The first liquid is poured to a level L1' below the cards, to a depth in the range from about 1–2.5 cm, and solidified, forming fugitive lamina L1'.

(2) The second liquid is then poured over the fugitive lamina to depth L2 and solidified, forming a composite header with a fixing lamina having a thickness L1'-L2.

(3) The composite header is demolded and the fugitive lamina removed, leaving the terminal portions **12"** protruding from the aft face of the finished header, which aft face is formed at what had been the level L1'. The finished header having a thickness L1'-L2 embeds the strips **15** (along with the rubber bands **18**, if used).

C. Illustrated third is the potting of skein fibers to form a finished headers with a cushioning lamina embedding the fibers on the opposed (fore) faces of the headers from which the strips will be removed.

The restricted swayability of the fibers generates some intermittent 'snapping' motion of the fibers. This motion has been found to break the potted fibers around their circumferences, at the interface of the fore face and substrate. The hardness of the fixing material which forms a "fixing lamina" was found to initiate excessive shearing forces at the circumference of the fiber. The deleterious effects of such forces is minimized by providing a cushioning lamina of material softer than the fixing lamina. Such a cushioning lamina is formed integrally with the fixing lamina by pouring cushioning liquid (so termed for its function when cured) over the fixing lamina to a depth L3 as shown in FIG. 4, which depth is sufficient to provide enough 'give' around the circumferences of the fibers to minimize the risk of shearing. Such cushioning liquid, when cured is rubbery, having a hardness in the range from about Shore A 30 to Shore D 45, and is preferably a polyurethane or silicone or other rubbery material which will adhere to the fixing lamina. Upon removal of the fugitive lamina, the finished header thus formed has the combined thicknesses of the fixing lamina and the cushioning lamina, namely L1-L3 when the strips **15** are cut away.

D. illustrated fourth is the formation a finished header with a gasketing lamina embedding the fibers on the header's

aft face, and a cushioning lamina embedding the fibers on the header's fore face; the strips are to be removed.

Whichever finished header is made, it is preferably fitted into a permeate pan **20** as illustrated in FIG. 2 with a peripheral gasket. It has been found that it is easier to seal the pan against a gasketing lamina, than against a peripheral narrow gasket. A relatively soft gasketing material having a hardness in the range from Shore A 40 to Shore D 45, is desirable to form a gasketing lamina integrally with the aft face of the finished header. In the embodiment in which the strips are cut away, the fugitive lamina is formed as before, and a gasketing liquid (so termed because it forms the gasket when Cured) is poured Over the surface of the fugitive lamina to a depth **L4**. The gasketing liquid is then cured. Upon removal of the fugitive lamina, when the strips **15** are cut away, the finished header thus formed has the combined thicknesses of the gasketing lamina (**L1-L4**), the fixing lamina (**L4-L2**) and the cushioning lamina (**L2-L3**), namely an overall **L1-L3**.

In another embodiment, to avoid securing the pan to the header with a gasketing means, and, to avoid positioning one or more gas-distribution manifolds in an optimum location near the base of the skein fibers after a skein is made, the manifolds are formed integrally with a header. Referring to FIG. 5 there is illustrated in perspective view an "integral single skein" referred to generally by reference numeral **100**. The integral single skein is so termed because it includes an integral finished header **101** and permeate pan **102**. The pan **102** is provided with a permeate withdrawal nipple **106**, and fitted with vertical air-tubes **103** which are to be embedded in the finished header. The air-tubes are preferably manifolded on either side of the skein fibers, to feeder air-tubes **104** and **105** which are snugly inserted through grommets in the walls of the pan. The permeate nipple **106** is then plugged, and a stack of arrays is held vertically in the pan in which a fugitive lamina is formed embedding both the ends of the fibers and the lower portion of the vertical air-tubes **103**. A fixing lamina is then formed over the fugitive lamina, embedding the fibers to form a fixing lamina through which protrude the open ends of the air-tubes **103**. The fugitive lamina is then melted and withdrawn through the nipple **106**. In operation, permeate collects in the permeate pan and is withdrawn through nipple **106**.

FIG. 6 illustrates a cross-section of an integral single skein **110** with another integral finished header **101** having a thickness **L1-L2**, but without a cushioning lamina, formed in a procedure similar to that described hereinabove. A permeate pan **120** with outwardly flared sides **120'** and transversely spaced-apart through-apertures therein, is prefabricated between side walls **111** and **112** so the pan is spaced above the bottom of the reservoir.

A pair of air-manifolds **107** such as shown in FIGS. 7A or 7B, is positioned and held in mirror-image relationship with each other adjacent the permeate pan **120**, with the vertical air-tubes **103** protruding through the apertures in sides **120'**, and the ends **104** and **105** protrude from through-passages in the vertical walls on either side of the permeate pan. Permeate withdrawal nipple **106** (FIG. 6) is first temporarily plugged. The stack of strips **15** is positioned between air-tubes **103**, vertically in the pan **120** which is filled to level **L1** to form a fugitive lamina, the level being just beneath the lower edges of the strips **15** which will not be removed. When solidified, the fugitive lamina embeds the terminal portions of the fibers **12** and also fills permeate tube **106**. Then the second liquid is poured over the upper surface of the fugitive lamina until the liquid covers the strips **15** but leaves the upper ends of the air-tubes **103** open. The second

liquid is then cured to form the fixing lamina of the composite header which is then heated to remove the fugitive material through the permeate nozzle **106** after it is unplugged.

FIG. 7A schematically shows in perspective view, an air-manifold **107** having vertical air-tubes **103** rising from a transverse header-tube which has longitudinally projecting feeder air-tubes **104** and **105**. The bore of the air-tubes which may be either "fine bubble diffusers", or "coarse bubble diffusers", or "aerators", is chosen to provide bubbles of the desired diameter under operating conditions, the bore typically being in the range from 0.1 mm to 5 mm. Bubbles of smaller diameter are preferably provided with a perforated transverse tube **103'** of an air-manifold **107'** having feeder air tubes **104'** and **105'**, illustrated in FIG. 7B. In each case, the bubbles function as a mechanical brush.

The skein fibers for the upper header of the skein are potted in a manner analogous to that described above in a similar permeate pan to form a finished header, except that no air manifolds are inserted.

Referring to FIG. 8 there is schematically illustrated, in a cross-sectional perspective view, an embodiment in which a bank of two skeins is potted in a single integral finished header enclosure, referred to generally by reference numeral **120b**. The term "header enclosure" is used because its side walls **121** and **122**, and end walls (not shown) enclose a plenum in which air is introduced. Instead of a permeate pan, permeate is collected from a permeate manifold which serves both skeins. Another similar upper enclosure **120u** (not shown), except that it is a flat-bottomed channel-shaped pan (inverted for use as the upper header) with no air-tubes molded in it, has the opposed terminal portions of all the skein fibers potted in the pan. For operation, both the lower and upper enclosures **120b** and **120u**, with their skein fibers are lowered into a reservoir of the substrate to be filtered. The side walls **121** and **122** need not rest on the bottom of the reservoir, but may be mounted on a side wall of the reservoir.

The side walls **121** and **122** and end walls are part of an integrally molded assembly having a platform **123** connecting the walls, and there are aligned multiple risers **124** molded into the platform. The risers resemble an inverted test-tube, the diameter of which need only be large enough to have an air-tube **127** inserted through the top **125** of the inverted test-tube. As illustrated, it is preferred to have "n+1" rows of air-tubes for "n" stacks of arrays to be potted. Crenelated platform **123** includes risers **124** between which lie channels **128** and **129**. Channels **128** and **129** are each wide enough to accept a stack of arrays of fibers **12**, and the risers are wide enough to have air-tubes **127** of sufficient length inserted therethrough so that the upper open ends **133** of the air-tubes protrude from the upper surface of the fixing material **101**. The lower ends **134** of the air-tubes are sectioned at an angle to minimize plugging, and positioned above the surface **S** of the substrate. The channel **129** is formed so as to provide a permeate withdrawal tube **126** integrally formed with the platform **123**. Side wall **122** is provided with an air-nipple **130** through which air is introduced into the plenum formed by the walls of the enclosure **120b**, and the surface **S** of substrate under the platform **123**. Each stack is potted as described in relation to FIG. 6 above, most preferably by forming a composite header of fugitive PEG Wax and epoxy resin around the stacks of arrays positioned between the rows of risers **124**, making sure the open ends of the air-tubes are above the epoxy fixing material, and melting out the wax through the permeate withdrawal tube **126**. When air is introduced into the enclo-

sure the air will be distributed through the air-tubes between and around the skeins.

Referring to FIG. 9 there is shown a schematic illustration of a skein having upper and lower headers 41u and 41b respectively, and in each, the protruding upper and lower ends 12u" and 12b" are evidence that the face of the header was not cut to expose the fibers. The height of the contiguous intermediate portions 12u' and 12b' respectively, corresponds to the cured depth of the fixing material.

It will now be evident that the essential feature of the foregoing potting method is that a fugitive lamina is formed which embeds the openings of the terminal portions of the fibers before their contiguous intermediate portions 12u' and 12u" and 12b' and 12b" are fixed respectively in a fixing lamina of the header. An alternative choice of materials is the use of a fugitive potting compound which is soluble in a non-aqueous liquid in which the fixing material is not soluble. Still another choice is to use a water-insoluble fugitive material which is also insoluble in non-aqueous liquids typically used as solvents, but which fugitive material has a lower melting point than the final potting material which may or may not be water-soluble.

The fugitive material is inert relative to both, the material of the fibers as well as the final potting material to be cast, and the fugitive material and fixing material are mutually insoluble. Preferably the fugitive material forms a substantially smooth-surfaced solid, but it is critical that the fugitive material be at least partially cured, sufficiently to maintain the shape of the header, and remain a solid above a temperature at which the fixing material is introduced into the header mold. The fugitive lamina is essentially inert and insoluble in the final potting material, so that the fugitive lamina is removably adhered to the fixing lamina.

The demolded header is either heated or solvent extracted to remove the fugitive lamina. Typically, the fixing material is cured to a firm solid mass at a first curing temperature no higher than the melting point or Tg of the fugitive lamina and preferably at a temperature lower than about 60° C.; the firm solid is then post-cured at a temperature high enough to melt the fugitive material but not high enough to adversely affect the curing of the fixing material or the properties of the fibers. The fugitive material is removed as described hereinafter, the method of removal depending upon the fugitive material and the curing temperature of the final potting material, used.

Since, during operation, a high flux is normally maintained if cleansing air contacts substantially all the fibers, it will be evident that when it is desirable to have a skein having a cross-section which is other than generally rectangular, for example elliptical or circular, or having a geometrically irregular periphery, and it is desired to have a large number of skein fibers, it will be evident that the procedure for stacking consecutive peripheral arrays described above will be modified. Further, the transverse central air-tube 52 (see FIG. 9) is found to be less effective in skeins of non-rectangular cross-section than a vertical air-tube which discharges air radially along its vertical length and which vertical air-tube concurrently serves as the spacing means. Such skeins with a generally circular or elliptical cross-section with vertical air-tubes are less preferred to form a bank, but provide a more efficient use of available space in a reservoir than a rectangular skein.

Referring further to FIG. 2, the header 11 has front and rear walls defined by vertical (z-axis) edges 11' and longitudinal (x-axis) edges 13'; side walls defined by edges 11' and transverse (y-axis) edges 13"; and a base 13 defined by edges 13' and 13".

The collection pan 20 is sized to snugly accommodate the base 13 above a permeate collection zone within the pan. This is conveniently done by forming a rectangular pan having a base 23 of substantially the same length and width dimensions as the base 13. The periphery of the pan 20 is provided with a peripheral step as shown in FIG. 2A, in which the wall 20' of the pan terminates in a step section 22, having a substantially horizontal shoulder 22" and a vertical retaining wall 22'.

FIG. 2B is a bottom plan view of the lower face of header 13 showing the open ends of the fibers 12' prevented from touching each other by potting resin. The geometrical distribution of fibers provides a regular peripheral boundary 14 (shown in dotted outline) which bounds the peripheries of the open ends of the outermost fibers.

Permeate flows from the open ends of the fibers onto the base 23 of the pan 20, and flows out of the collection zone through a permeate withdrawal conduit 30 which may be placed in the bottom of the pan in open flow communication with the inner portion of the pan. When the skein is backwashed, backwashing fluid flows through the fibers and into the substrate. If desired, the withdrawal conduit may be positioned in the side of the pan as illustrated by conduit 30'. Whether operating under gravity alone, or with a pump to provide additional suction, it will be apparent that a fluid-tight seal is necessary between the periphery of the header 11 and the peripheral step 22 of the pan 20. Such a seal is obtained by using any conventional means such as a suitable sealing gasket or sealing compound, typically a polyurethane or silicone resin, between the lower periphery of the header 11 and the step 22. As illustrated in FIG. 2, permeate drains downward, but it could also be withdrawn from upper permeate port 45u in the upper permeate pan 43u (see FIG. 9).

It will now be evident that a header with a circular periphery may be constructed, if desired. Headers with geometries having still other peripheries (for example, an ellipse) may be constructed in an analogous manner. If desired, but rectangular headers are most preferred for ease of construction with multiple linear arrays.

Referring to FIGS. 9 and 2A, six rows of fibers 12 are shown on either side of a gas distribution line 52 which traverses the length of the rows along the base of the fibers. The potted terminal end portions 12b" open into permeate pan 43b. Because portions 12u and 12b" of individual fibers 12 are potted, and the fibers 12 are preferably from 1% to 2% longer than the fixed distance between upper and lower headers 41u and 41b, the fibers between opposed headers are generally parallel to one another, but are particularly parallel near each header. Also held parallel are the terminal end portions 12u" and 12b" of the fibers which protrude from the headers with their open ends exposed. The fibers protrude below the lower face of the bottom header 41b, and above the upper face of the upper header 41u. The choice of fiber spacing in the header will determine packing density of the fibers near the headers, but fiber spacing is not a substantial consideration because spacing does not substantially affect specific flux during operation. It will be evident however, that the more fibers, the more tightly packed they will be giving more surface area.

Since the length of fibers tends to change while in service, the extent of the change depending upon the particular composition of the fibers, and the spacing between the upper and lower headers is critical, it is desirable to mount the headers so that one is adjustable in the vertical direction relative to the other, as indicated by the arrow V. This is conveniently done by attaching the pan 43u to a plate 19

having vertically spaced apart through-passages **34** through which a threaded stud **35** is inserted and secured with a nut **36**. Threaded stud **35** is in a fixed mounting block **37**.

The density of fibers in a header is preferably chosen to provide the maximum membrane surface area per unit volume of substrate without adversely affecting the circulation of substrate through the skein. A gas-distribution means **52** such as a perforated air-tube, provides air within the skein so that bubbles of gas (air) rise upwards while clinging to the outer surfaces of the fibers, thus efficiently scrubbing them. If desired, additional air-tubes **52'** may be placed on either side of the skein near the lower header **41b**, as illustrated in phantom outline, to provide additional air-scrubbing power. Whether the permeate is withdrawn from the upper header through port **45u** or the lower header through port **45b**, or both, depends upon the particular application, but in all instances, the fibers have a substantially vertical orientation.

The vertical skein is deployed in a substrate to present a generally vertical profile, but has no structural shape. Such shape as it does have changes continuously, the degree of change depending upon the flexibility of the fibers, their lengths, the overall dimensions of the skein, and the degree of movement imparted to the fibers by the substrate and also by the oxygen-containing gas from the gas-distribution means.

Referring to FIG. **10** there is illustrated a typical assembly referred to as a "wall-mounted bank" which includes at least two side-by-side skeins, indicated generally by reference numerals **40** and **40'** with their fibers **42** and **42'**; fibers **42** are potted in upper and lower headers **41u** and **41b** respectively; and fibers **42'** in headers **41u'** and **41b'**; headers **41u** and **41b** are fitted with permeate collecting means **46u** and **46b** respectively; headers **41u'** and **41b'** are fitted with permeate collecting means **46u'** and **46b'** respectively; and, the skeins share a common gas-distribution means **50**. A "bank" of skeins is typically used to retrofit a huge, deep tank from which permeate is to be withdrawn using a vacuum pump. In a large reservoir, several banks of skeins may be used in side-by-side relationship within a tank. Each skein includes multiple rows (only one row is shown) of fibers **42** and **42'** in upper headers **41u** and **41u'**, and lower headers **41b** and **41b'** respectively, and arms **51** and **51'** of gas-distribution means **50** are disposed between the lower headers **41b** and **41b'** near their bases. The upper headers **44u** and **44u'** are mounted by one of their ends to a vertical interior surface of the wall **W** of a tank, with mounting brackets **53** and **53'** and suitable fastening means such as bolts **54**. The wall **W** thus functions as a spacer means which fixes the distance between the upper and lower headers. Each upper header is provided with a permeate collection pan **43u** and **43u'**, respectively, connected to permeate withdrawal conduits **45u** and **45u'** and manifolded to permeate manifold **46u** through which permeate being filtered into the collection pans is continuously withdrawn. Each header is sealingly bonded around its periphery, to the periphery of each collection pan.

The skein fibers (only one array of which is shown for clarity) shown in this perspective view have an elongated rectangular parallelepiped shape the sides of which are irregularly shaped when immersed in a substrate, because of the random side-to-side displacement of fibers as they sway. An elongated rectangular parallelepiped shape is preferred since it permits a dense packing of fibers, yet results in excellent scrubbing of the surfaces of the fibers with bubbles. With this shape, a skein may be formed with from 10 to 50 arrays of fibers across the longitudinal width 'w' of

the headers **41u**, **41b**, and **41u'**, **41b'** with each array having fibers extending along the transverse length 'l' of each header. Air-tubes on either side of a skein effectively cleanse the fibers if there are less than about 30 arrays between the air-tubes. A skein having more than 30 arrays is preferably also centrally aerated as illustrated by the air-tube **52** in FIG. **9**.

Thus, if there are about **100** fibers closely spaced-apart along the transverse length 'l' of an array, and there are 25 arrays in a skein in a header of longitudinal width 'w', then the opposed terminal end portions of 2500 fibers are potted in headers **41u** and **41b**. The open ends of all fibers in headers **41b** and **41b'** point downwards into collection zones in collection pans **43b** and **43b'** respectively, and those of all fibers in headers **41u** and **41u'** point upwards into collection zones in collection pans **43u** and **43u'** respectively. Withdrawal conduits **45u** and **45u'** are manifolded to permeate manifold **46u** through which permeate collecting in the upper collection pans **41u** and **43u'** is typically continuously withdrawn. If the permeate flow is high enough, it may also be withdrawn from the collection pans **43b** and **43b'** through withdrawal conduits **45b** and **45b'** which are manifolded to permeate manifold **46b**. When permeate is withdrawn in the same plane as the permeate withdrawal conduits **45u**, **45u'** and manifold **46u**, and the transmembrane pressure differential of the fibers is in the range from 35–75 kPa (5–10 psi), manifold **46u** may be connected to the suction side of a centrifugal pump which will provide adequate NPSH.

In general, the permeate is withdrawn from both the upper and lower headers, until the flux declines to so low a level as to require that the fibers be backwashed. The skeins may be backwashed by introducing a backwashing fluid through the upper permeate collection manifold **46u**, and removing the fluid through the lower manifold **46b**. Typically, from 3 to 30 skeins may be coupled together for internal fluid communication with one and another through the headers, permeate withdrawal means and the fibers; and, for external fluid communication with one another through an air manifold. Since the permeate withdrawal means is also used for backflushing it is generally referred to as a 'liquid circulation means', and as a permeate withdrawal means only when it is used to withdraw permeate.

When deployed in a substrate containing suspended and dissolved organic and inorganic matter, most fibers of organic polymers remain buoyant in a vertical position. The fibers in the skein are floatingly buoyed in the substrate with the ends of the fibers anchored in the headers. This is because (i) the permeate is essentially pure water which has a specific gravity less than that of the substrate, and most polymers from which the fibers are formed also have a specific gravity less than 1, and, (ii) the fibers are buoyed by bubbles which contact them. Fibers made from ceramic, or, glass fibers are heavier than water.

Adjacent the skeins, an air-distribution manifold **50** is disposed below the base of the bundle of fibers, preferably below the horizontal plane through the horizontal center-lines of the headers. The manifold **50** is preferably split into two foraminous arms **51** and **51'** adjacent the bases of headers **41b** and **41b'** respectively, so that when air is discharged through holes in each portion **51** and **51'**, columns of bubbles rise adjacent the ends of the fibers and thereafter flow along the fibers through the skeins. If desired, additional portions (not shown) may be used adjacent the bases of the lower headers but located on the outside of each, so as to provide additional columns of air along the outer surfaces of the fibers.

The type of gas (air) manifold is not narrowly critical provided it delivers bubbles in a preferred size range from

about 1 mm to 25 mm, measured within a distance of from 1 cm, to 50 cm from the through-passages generating them. If desired, each portion **51** and **51'** may be embedded in the upper surface of each header, and the fibers potted around them, making sure the air-passages in the portions **51** and **51'** are not plugged with potting compound. If desired, additional arms of air-tubes may be disposed on each side of each lower header, so that fibers from each header are scrubbed by columns of air rising from either transverse side.

The air may be provided continuously or intermittently, better results generally being obtained with continuous air flow. The amount of air provided depends upon the type of substrate, the requirements of the type of microorganisms, if any, and the susceptibility of the surfaces of the fibers to be plugged, there always being sufficient air to produce desired growth of the microorganisms when operated in a substrate where maintaining such growth is essential.

Referring to FIG. **11**, there is schematically illustrated another embodiment of an assembly, referred to as a "stand-alone bank" of skeins, two of which are referenced by numeral **60**. The bank is referred to as being a "stand-alone" because the spacer means between headers is supplied with the skeins, usually because mounting the skeins against the wall of a reservoir is less effective than placing the bank in spaced-apart relationship from a wall. In other respects, the bank **60** is analogous to the wall-mounted bank illustrated in FIG. **10**.

Each bank **60** with fibers **62** (only a single row of the multiple, regularly spaced apart generally vertical arrays is shown for the sake of clarity) is deployed between upper and lower headers **61u** and **61b** in a substrate 'S'. The lower headers rest on the floor of the reservoir. The upper headers are secured to rigid vertical air tubes **71** and **71'** through which air is introduced into a tubular air manifold identified generally by reference numeral **70**. The manifold **70** includes (i) the vertical tubular arms **71** and **71'**; (ii) a lower transverse arm **72** which is perforated along the length of the lower header **61b'** and secured thereto; the arm **72** communicates with longitudinal tubular arm **73**, and optionally another longitudinal arm **73'** (not shown) in mirror-image relationship with arm **73** on the far side of the headers; and (iii) transverse arms **74** and **74'** in open communication with **72** and **73**; arms **74** and **74'** are perforated along the visible transverse faces of the headers **61b** and **61b'**, and **74** and **74'** may communicate with tubular arm **73'** if it is provided. The vertical air-tubes **71** and **71'** conveniently provide the additional function of a spacer means between the first upper header and the first lower header, and because the remaining headers in the bank are also similarly (not shown) interconnected by rigid conduits, the headers are maintained in vertically and transversely spaced-apart relationship. Since all arms of the air manifold are in open communication with the air supply, it is evident that uniform distribution of air is facilitated.

As before, headers **61u** and **61u'** are each secured in fluid-tight relationship with collection zones in collection pans **63u** and **63u'** respectively, and each pan has withdrawal conduits **65u** and **65u'** which are manifolded to longitudinal liquid conduits **81** and **81'**. Analogously, headers **61b** and **61b'**, are each secured in fluid-tight relationship with collection zones in collection pans **63b** and **63b'** respectively, and each pan has withdrawal conduits **65b** and **65b'** which are manifolded to longitudinal conduits **82** and **82'**. As illustrated withdrawal conduits are shown for both the upper and the lower headers, and both fore and aft the headers. In many instances, permeate is withdrawn from only an upper manifold which is provided on only one side of the upper

headers. A lower manifold is provided for backwashing. Backwashing fluid is typically flowed through the upper manifold, through the fibers and into the lower manifold. The additional manifolds on the aft ends of the upper and lower headers not only provides more uniform distribution of backwashing fluid but support for the interconnected headers. It will be evident that, absent the aft interconnecting upper conduit **81'**, an upper header such as **61u** will require to be spaced from its lower header by some other interconnection to header **61u'** or by a spacer strut between headers **61u** and **61b**.

In the best mode illustrated, each upper header is provided with rigid PVC tubular nipples adapted to be coupled with fittings such as ells and tees to the upper conduits **81** and **81'** respectively. Analogously, each lower header is connected to lower conduits **82** and **82'** (not shown) and/or spacer struts are provided to provide additional rigidity, depending upon the number of headers to be interconnected, permeate is withdrawn through an upper conduit, and all piping connections, including the air connection, are made above the liquid level in the reservoir.

The length of fibers (between headers) in a skein is generally chosen to obtain efficient use of an economical amount of air, so as to maintain optimum flux over a long period of time. Other considerations include the depth of the tank in which the bank is to be deployed, the positioning of the liquid and air manifolds, and the convection patterns within the tank, inter alia.

In another embodiment of the invention, a bioreactor is retrofitted with plural banks of skeins schematically illustrated in the elevational view shown in FIG. **12**, and the plan view shown in FIG. **13**. The clarifier tank is a large circular tank **90** provided with a vertical circular outer baffle **91**, a vertical circular inner baffle **92**, and a bottom **93** which slopes towards the center (apex) for drainage of accumulating sludge. Alternatively, the baffles may be individual, closely spaced rectangular plates arranged in outer and inner circles, but continuous cylindrical baffles (shown) are preferred. Irrespective of which baffles are used, the baffles are located so that their bottom peripheries are located at a chosen vertical distance above the bottom. Feed is introduced through feed line **94** in the bottom of the tank **90** until the level of the substrate rises above the outer baffle **91**.

A bank **60** of plural skeins **10**, analogous to those in the bank depicted in FIG. **10**, each of which skeins is illustrated in FIG. **9**, is deployed against the periphery of the inner wall of the bioreactor with suitable mounting means in an outer annular permeate extraction zone **95'** (FIG. **13**) formed between the circular outer baffle **91** and the wall of the tank **90**, at a depth sufficient to submerge the fibers. A clarification zone **91'** is defined between the outer circular baffle **91** and inner circular baffle **92**. The inner circular baffle **92** provides a vertical axial passage **92'** through which substrate is fed into the tank **90**. The skeins form a dense curtain of fibers in radially extending, generally planar vertical arrays as illustrated in FIG. **9**, potted between upper and lower headers **41u** and **41b**. Permeate is withdrawn through manifold **46u** and air is introduced through air-manifold **80**, extending along the inner wall of the tank, and branching out with air-distribution arms between adjacent headers, including outer distribution arms **84'** on either side of each lower header **41b** at each end of the bank. The air manifold **80** is positioned between skeins in the permeate extraction zone **95'** in such a manner as to have bubbles contact essentially the entire surface of each fiber which is continuously awash with bubbles. Because the fibers are generally vertical, the air is in contact with the surfaces of the fibers longer than if

they were arcuate, and the air is used most effectively to maintain a high flux for a longer period of time than would otherwise be maintained.

It will be evident that if the tank is at ground level, there will be insufficient liquid head to induce a desirable liquid head under gravity alone. Without an adequate siphoning effect, a centrifugal pump may be used to produce the necessary suction. Such a pump should be capable of running dry for a short period, and of maintaining a vacuum on the suction side of from 25.5 cm (10")–51 cm (20") of Hg, or –35 kPa (–5 psi) to –70 kPa (–10 psi). Examples of such pumps rated at 18.9 L/min (5 gpm) @15" Hg, are (i) flexible-impeller centrifugal pumps, e.g. Jabsco #30510-2003; (ii) air operated diaphragm pumps, e.g. Wilden M2; (iii) progressing cavity pumps, e.g. Ramoy 3561; and (iv) hosepumps, e.g. Waukesha SP 25.

The skein may also be potted in a header which is not a rectangular prism, preferably in cylindrical upper and lower headers in which substantially concentric arrays of fibers are non-removably potted in cylindrical permeate pans, and the headers are spaced apart by a central gas tube which functions as both the spacer means and the gas-distribution means which is also potted in the headers. As before, the fibers are restrictedly swayable, but permeate is withdrawn from both upper and lower headers through a single permeate pan so that all connections for the skein, when it is vertically submerged, are from above. Permeate is preferably withdrawn from the lower permeate pan through a central permeate withdrawal tube which is centrally axially held within the central gas (air) tube. The concentric arrays are formed by wrapping successive sheets of flat arrays around the central air-tube, and gluing them together before they are potted. This configuration permits the use of more filtration surface area per unit volume of a reservoir, compared to skeins with rectangular prism headers, using the same diameter and length of fibers.

EXAMPLE

Microfiltration of an activated sludge at 30° C. having a concentration of 25 g/L (2.5% TSS) is carried out with a skein of polysulfone fibers in a pilot plant tank. The fibers are "air scrubbed" at a flow rate of 12 CFM (0.34 m³/min) with a coarse bubble diffuser generating bubbles in the range from about 5 mm to 25 mm, in nominal diameter. The air is sufficient not only for the oxidation requirements of the biomass but also for adequate scrubbing. The fibers have an outside diameter of 1.7 mm, a wall thickness of about 0.5 mm, and a surface porosity in the range from about 20% to 40% with pores about 0.2 μm in diameter, both latter physical properties being determined by a molecular weight cut off at 200,000 Daltons. The skein which has 1440 fibers with a surface area of 12 m², is wall-mounted in the tank, the vertical spaced apart distance of the headers being about 1% less than the length of a fiber in the skein. The opposed ends of the fibers are potted in upper and lower headers respectively, each about 41 cm long and 10 cm wide. The fixing material of the headers is an epoxy having a hardness of about 70 Shore D with additional upper and lower laminae of softer polyurethane (about 60 Shore A and 30 Shore D respectively) above and below the epoxy lamina, and the fibers are potted to a depth sufficient to have their open ends protrude from the bottom of the header. The average transmembrane pressure differential is about 34.5 kPa (5 psi). Permeate is withdrawn through lines connected to the collection pan of each header with a pump generating about 34.5 kPa (5 psi) suction. Permeate is withdrawn at a specific flux of about 0.7 l/m²h/kPa yielding about 4.8 l/min of

permeate which has an average turbidity of <0.8 NTU, which is a turbidity not discernible to the naked eye.

It will now be evident that the membrane device and basic separation processes of this invention may be used in the recovery and separation of a wide variety of commercially significant materials, some of which, illustratively referred to, include the recovery of water from ground water containing micron and submicron particles of siliceous materials, preferably "gas scrubbing" with carbon dioxide; or, the recovery of solvent from paint-contaminated solvent. In each application, the choice of membrane will depend upon the physical characteristics of the materials and the separation desired. The choice of gas will depend on whether oxygen is needed in the substrate.

In each case, the simple process comprises, disposing a skein of a multiplicity of hollow fiber membranes, or fibers each having a length >0.5 meter, together having a surface area >1 m², in a body of substrate which is unconfined in a modular shell, so that the fibers are essentially restrictedly swayable in the substrate. The substrate is typically not under pressure greater than atmospheric. The fibers have a low transmembrane pressure differential in the range from about 3.5 kPa (0.5 psi) to about 350 kPa (50 psi), and the headers, the terminal portions of the fibers, and the ends of the fibers are disposed in spaced-apart relationship as described hereinabove, so that by applying a suction on the aft face of at least one of the headers, preferably both, permeate is withdrawn through the collection means in which each header is mounted in fluid-tight communication. Having thus provided a general discussion, and specific illustrations of the best mode of constructing and deploying a membrane device comprising a skein of long fibers in a substrate from which a particular component is to be produced as permeate, how the device is used in a gas-scrubbed skein, and having provided specific illustrative systems and processes in which the skein is used, it is to be understood that no undue restrictions are to be imposed by reason of the specific embodiments illustrated and discussed, and particularly that the invention is not restricted to a slavish adherence to the details set forth herein.

We claim:

1. In a microfiltration membrane device, for withdrawing permeate essentially continuously from a multicomponent liquid substrate while increasing the concentration of particulate material therein, said membrane device including:

a multiplicity of hollow fiber membranes, or fibers, unconfined in a shell of a module, said fibers together having a surface area >1 m², said fibers being swayable in said substrate, said fibers being subject to a transmembrane pressure differential in the range from about 0.7 kPa (0.1 psi) to about 345 kPa (50 psi), and each fiber having a length >0.5 meter;

a first header and a second header disposed in transversely spaced-apart relationship with said second header within said substrate;

said first header and said second header having opposed terminal end portions of each fiber sealingly secured therein, all open ends of said fibers extending from a permeate-discharging face of at least one header;

permeate collection means to collect said permeate, sealingly connected in open fluid communication with a permeate-discharging face of each of said headers; and, means to withdraw said permeate;

[the improvement comprising.]

said fibers, said headers and said permeate collection means together forming a vertical skein wherein said

fibers are essentially vertically disposed and terminal end portions of individual fibers are potted in proximately spaced-apart relationship in cured resin;

said first header being upper and disposed in vertically spaced-apart relationship above said second header, with opposed faces at a fixed distance; each of said fibers having substantially the same length, said length being from 0.1% to less than 5% greater than said fixed distance so as to permit restricted displacement of an intermediate portion of each fiber, independently of the movement of another fiber[.];

the improvement comprising,

each said header having said fibers spaced apart by a support means having a thickness corresponding to a desired lateral spacing between adjacent fibers, said support means extending over only each terminal portion of said fibers near their ends, so as to maintain said ends in spaced apart relationship.

2. The membrane device of claim 1 wherein each said header is a mass of synthetic resinous material in which said terminal end portions are potted and said fibers are formed from an organic resinous material or a ceramic.

3. The membrane device of claim 2 wherein each said hollow fiber has an outside diameter in the range from about 20 μm to about 3 mm, a wall thickness in the range from about 5 μm to about 2 mm, and, said fiber is formed from a material selected from the group consisting of natural and synthetic polymers, and pore size in the range from 1000 \AA to 10000 \AA , and, said displacement is in the lateral or horizontal direction.

4. The membrane device of claim 3 wherein said transmembrane pressure differential is in the range from 3.5 kPa (0.5 psi) to about 175 kPa (25 psi), said fibers are in the range from 0.5 m to 5 m long, and said terminal end portions of said fibers are potted within said mass of thermosetting synthetic resinous material to a depth in the range from about 1 cm to about 5 cm.

5. The membrane device of claim 3 wherein said substrate is maintained at a pressure in the range from about 1–10 atm, said fibers extend as a skein upwardly from a fiber-supporting face of each of said headers, each header is a rectangular prism having substantially the same dimensions, said fibers extend downwardly through the permeate-discharging face of said headers, and said permeate is discharged upwardly relative to said upper header.

6. The membrane device of claim 4 wherein said terminal end portions of said fibers are potted within a mass of thermosetting synthetic resinous material to a depth in the range from about 1 cm to about 5 cm and protrude through a permeate-discharging face of each said header in a range from about 0.1 mm, to about 1 cm.

7. The membrane device of claim 6 wherein said open ends of fibers are bounded by a geometrically regular peripheral boundary around the outermost peripheries of the outermost fibers in the boundary, and the length of a fiber is essentially independent of the strength of said fiber, or its diameter.

8. The membrane device of claim 7 wherein said fibers together have a surface area in the range from 10 to 10^3 m^2 .

9. The membrane device of claim 8 wherein said first and second headers are each a rectangular parallelepiped and said first header is disposed parallel to said second header.

10. In a gas-scrubbed assembly comprising, a microfiltration membrane device in combination with a gas distribution means to minimize build-up of particulate deposits on the surfaces of hollow fiber membranes (“fibers”) in said device, and to recover permeate from a multicomponent

liquid substrate while leaving particulate matter therein, said membrane device comprising,

a multiplicity of fibers, unconfined in a shell of a module, said fibers together having a surface area $>1 \text{ m}^2$, said fibers being swayable in said substrate, said fibers being subject to a transmembrane pressure differential in the range from about 0.7 kPa (0.1 psi) to about 345 kPa (50 psi), and each having a length >0.5 meter;

a first and second header disposed in spaced-apart relationship within said substrate;

said first header and said second header having opposed terminal end portions of each fiber sealingly secured therein, all open ends of said fibers extending from a permeate-discharging face of at least one header;

permeate collection means to collect said permeate, sealingly connected in open fluid communication with a permeate-discharging face of each of said headers; and, means for withdrawing said permeate; and,

said gas-distribution means is located within a zone near the base of said skein, having through-passages therein adapted to have sufficient gas flowed therethrough to generate enough bubbles flowing in a column of rising bubbles through and around said skein fibers, to keep surfaces of said fibers awash in bubbles;

[the improvement comprising.]

said fibers, said headers and said permeate collection means together forming a skein wherein said fibers are essentially vertically disposed and terminal end portions of individual fibers are potted in proximately spaced-apart relationship in cured resin;

said first header being upper and disposed in vertically spaced-apart relationship above said second header at a fixed distance;

each of said fibers having substantially the same length, said length being from at least 0.1% greater, to less than 5% greater than said fixed distance so as to permit restricted displacement of an intermediate portion of each fiber, independently of the movement of another fiber;

the improvement comprising,

each said header having said fibers spaced apart by a support means having a thickness corresponding to a desired lateral spacing between adjacent fibers, said support means extending over only each terminal portion of said fibers near their ends, so as to maintain said ends in spaced apart relationship; and,

said gas distribution means having through-passages therein to discharge a cleansing gas in an amount in the range from 0.47–14 cm^3/sec per fiber (0.001 scfm/fiber to about 0.03 scfm/fiber) in a column of bubbles which rise vertically substantially parallel to, and in contact with said fibers, movement of which is restricted within said column;

whereby said permeate is essentially continuously withdrawn while concentration of said particulate matter in said substrate is increased.

11. The gas-scrubbed assembly of claim 10 wherein said fixed distance is adjustable, said gas-distribution means includes at least two distribution means disposed, one on each side of said skein, said gas-distribution means generate bubbles having an average diameter in the range from about 0.1 mm to about 25 mm which bubbles contact said fibers, maintain their buoyancy, and maintain said fibers’ outer surfaces essentially free from build-up of deposits of said particulate matter.

12. The gas-scrubbed assembly of claim 11 wherein said through-passages in said gas-distribution means generate bubbles in the size range from 1 mm to 25 mm in relatively close proximity, in the range from 1 cm to about 50 cm, to said through-passages.

13. The gas-scrubbed assembly of claim 10 wherein said fibers have pores in the size range from about 1000 Å to 10000 Å, each said header is a rectangular prism having substantially the same dimensions, said gas is an oxygen-containing gas, and said particulate matter comprises biologically active microorganisms growing in said substrate.

14. The gas-scrubbed assembly of claim 10 wherein said particulate matter comprises finely divided inorganic particles.

15. In a process for maintaining the outer surfaces of hollow fiber membranes essentially free from a build-up of deposits of particulate material while separating a permeate from a multicomponent liquid substrate in a reservoir, said process comprising,

submerging skein fibers within said substrate unconfined in a modular shell, said fibers being securely held in laterally opposed, spaced-apart first and second headers, said fibers having a transmembrane pressure differential in the range from about 0.7 kPa (0.1 psi) to about 345 kPa (50 psi), a total surface area $>1 \text{ m}^2$, and a length sufficiently greater than the direct distance between opposed faces of said first and second headers so as to present said skein in a swayable configuration above a horizontal plane through the horizontal centerline of a header;

mounting said headers in fluid-tight open communication with collection means to collect said permeate;

flowing a fiber-cleansing gas through a gas-distribution means proximately disposed relative to said skein, within a zone near the base of said skein, and contacting surfaces of said fibers with sufficient physical impact of bubbles of said gas to maintain essentially the entire length of each fiber in said skein awash with bubbles and essentially free from said build-up;

maintaining an essentially constant flux through said fibers substantially the same as an equilibrium flux initially obtained after commencing operation of said process;

collecting said permeate in said collection means; and, withdrawing said permeate,

the improvement comprising,

introducing a cleansing gas in an amount in the range from 0.47–14 cm^3/sec per fiber (0.001 scfm/fiber to about 0.03 scfm/fiber) to generate a column of said bubbles alongside and in contact with outer surfaces of said fibers;

deploying said skein fibers within said column in an essentially vertical configuration, with said headers in fixed spaced apart relationship at a fixed distance, said skein having fibers of substantially the same length and from at least 0.1% greater, to about 5% greater than said fixed distance, said fibers being independently swayable from side-to-side within a vertical zone of movement with terminal end portions of individual fibers potted in proximately spaced-apart relationship in cured resin;

restricting movement of said fibers to said vertical zone defined by lateral movement of outer fibers in said skein;

vertically gas-scrubbing said fibers' outside surfaces with bubbles which flow upward in contact with said surfaces;

maintaining said surfaces substantially free from said deposits of particulate matter during a period when specific flux through said fibers has attained equilibrium; and,

5 simultaneously, essentially continuously withdrawing said permeate while increasing the concentration of said particulate material in said substrate.

16. The process of claim 15 wherein each said hollow fiber has an outside diameter in the range from about 20 μm to about 3 mm, and a wall thickness in the range from about 5 μm to about 1 mm; each said header is formed from a mass of thermosetting or thermoplastic synthetic resinous material; terminal end portions of said fibers are potted within said resinous material to a depth in the range from about 1 cm to about 5 cm;

said particulate matter is selected from the group consisting of microorganisms and finely divided inorganic particles; and,

said gas-distribution means generates bubbles having an average diameter in the range from about 1 mm to about 25 mm.

17. A method of forming a header for a skein of a multiplicity of fibers, comprising,

forming a stack of at least two superimposed essentially coplanar and similar arrays, each array comprising a chosen number of fibers supported on a support means having a thickness corresponding to a desired lateral spacing between adjacent arrays;

holding the stack in a first liquid with terminal portions of the fibers submerged, until the liquid solidifies into a first shaped lamina provided that the first liquid is unreactive with material of the fibers;

pouring a second liquid over the first shaped lamina to embed the fibers to a desired depth, and solidifying the second liquid to form a fixing lamina upon the first shaped lamina, the second liquid also being substantially unreactive with either the material of the fibers or that of the first shaped lamina;

forming a composite header in which terminal portions of the fibers are potted, the composite header comprising a laminate of a fugitive lamina of fugitive material, and a contiguous finished header of fixing lamina; and,

removing the first shaped lamina without removing a portion of the fixing lamina so as to leave the ends of the fibers open and protruding from the aft face of the header,

whereby the open ends having a circular cross-section are exposed without cutting the fibers.

18. The method of claim 17 wherein said second liquid upon solidification forms a thermosetting or thermoplastic synthetic resin, and said first liquid upon solidification forms a solid which has a melting point or glass transition temperature lower than the melting point or glass transition temperature of said synthetic resin.

19. The method of claim 18 wherein said first liquid upon solidification is flowable at a temperature at which said second liquid upon solidification remains solid.

20. The method of claim 18 wherein said first liquid upon solidification is soluble in a chosen solvent, and said second liquid upon solidification is insoluble in said solvent.

21. A header in which a multiplicity of hollow fiber membranes or "fibers" is potted, said header comprising,

a molded body of arbitrary shape striated in a fixing lamina and a fugitive lamina, said fugitive lamina formed from a fugitive potting material and said fixing lamina formed from a fixing material;

said fibers having terminal portions thereof potted in said fugitive potting material which when solidified plugs ends of said fibers, plugged ends having an essentially circular cross-section, said fugitive lamina maintaining said ends in closely spaced-apart substantially parallel relationship;

said fugitive lamina having an aft face towards which said plugged ends protrude, and a fore face through which said fibers extend vertically;

said fugitive lamina having said fixing lamina adhered thereto, said fixing lamina having a thickness sufficient to maintain said fibers in substantially the same spaced-apart relationship relative to one and another as the spaced apart relationship in said lower portion.

22. The header of claim 21 wherein said fixing lamina has a cushioning lamina embedding said fibers and coextensively adhered to said fixing lamina, said fixing lamina has a hardness in the range from about Shore D 50 to Rockwell R 110, and said cushioning layer has a hardness in the range from Shore A 30 to Shore D 45.

23. In a microfiltration membrane device, for withdrawing permeate essentially continuously from a multicomponent liquid substrate while increasing the concentration of particulate material therein, said membrane device including:

a multiplicity of hollow fiber membranes, or fibers, unconfined in a shell of a module, said fibers together having a surface area $>1 \text{ m}^2$, said fibers being swayable in said substrate, said fibers being subject to a transmembrane pressure differential in the range from about 0.7 kPa (0.1 psi) to about 345 kPa (50 psi), and each fiber having a length >0.5 meter;

a first header and a second header disposed in transversely spaced-apart relationship with said second header within said substrate;

said first header and said second header having opposed terminal end portions of each fiber sealingly secured therein, all open ends of said fibers extending from a permeate-discharging face of at least one header;

permeate collection means to collect said permeate, sealingly connected in open fluid communication with a permeate-discharging face of each of said headers; and, means to withdraw said permeate;

said fibers, said headers and said permeate collection means together forming a vertical skein wherein said fibers are essentially vertically disposed and terminal end portions of individual fibers are potted in proximately spaced-apart relationship in cured resin;

said first header being upper and disposed in vertically spaced-apart relationship above said second header, with opposed faces at a fixed distance; each of said fibers having substantially the same length, said length being from 0.1% to less than 5% greater than said fixed distance so as to permit restricted displacement of an intermediate portion of each fiber, independently of the movement of another fiber;

the improvement comprising,

an air distribution means within said skein, said air distribution means having through-passages for bubbles rising through said skein, and including an air-tube maintaining said first and second headers in spaced-apart relationship.

24. The device of claim 23 wherein the upper and lower headers are cylindrical and said air tube is centrally located.

25. In a microfiltration membrane device, for withdrawing permeate essentially continuously from a multicompo-

nent liquid substrate while increasing the concentration of particulate material therein, said membrane device including:

a multiplicity of hollow fiber membranes, or fibers, unconfined in a shell of a module, said fibers together having a surface area $>1 \text{ m}^2$, said fibers being swayable in said substrate, said fibers being subject to a transmembrane pressure differential in the range from about 0.7 kPa (0.1 psi) to about 345 kPa (50 psi), and each fiber having a length >0.5 meter;

a first header and a second header disposed in transversely spaced-apart relationship with said second header within said substrate;

said first header and said second header having opposed terminal end portions of each fiber sealingly secured herein, all open ends of said fibers extending from a permeate-discharging face of at least one header;

permeate collection means to collect said permeate, sealingly connected in open fluid communication with a permeate-discharging face of each of said headers; and, means to withdraw said permeate;

said fibers, said headers and said permeate collection means together forming a vertical skein wherein said fibers are essentially vertically disposed and terminal end portions of individual fibers are potted in proximately spaced-apart relationship in cured resin;

said first header being upper and disposed in vertically spaced-apart relationship above said second header, with opposed faces at a fixed distance; each of said fibers having substantially the same length, said length being from 0.1% to less than 5% greater than said fixed distance so as to permit restricted displacement of an intermediated portion of each fiber, independently of the movement of another fiber;

the improvement comprising,

a gas distribution means having through-passages for bubbles rising through said skein, and said through-passages are integral with said lower header.

26. The device of claim 25, wherein said through-passages in said lower header are in open communication with a plenum integral with said lower header.

27. In a microfiltration membrane device, for withdrawing permeate essentially continuously from a multicomponent liquid substrate while increasing the concentration of particulate material therein, said membrane device including:

a multiplicity of hollow fiber membranes, or fibers, unconfined in a shell of a module, said fibers together having a surface area $>1 \text{ m}^2$, said fibers being swayable in said substrate, said fibers being subject to a transmembrane pressure differential in the range from about 0.7 kPa (0.1 psi) to about 345 kPa (50 psi), and each fiber having a length >0.5 meter;

a first header and a second header disposed in transversely spaced-apart relationship with said second header with said substrate;

said first header and said second header having opposed terminal end portions of each fiber sealingly secured therein, all open ends of said fibers extending from a permeate-discharging face of at least one header;

permeate collection means to collect said permeate, sealingly connected in open fluid communication with a permeate-discharging face of each of said headers; and, means to withdraw said permeate;

said fibers, said headers and said permeate collection means together forming a vertical skein wherein said

35

fibers are essentially vertically disposed and terminal end portions of individual fibers are potted in proximately spaced-apart relationship in cured resin;

said first header being upper and disposed in vertically spaced-apart relationship above said second header, with opposed faces at a fixed distance, each of said fibers having substantially the same length, said length being from 0.1% to less than 5% greater than said fixed distance so as to permit restricted displacement of an intermediate portion of each fiber, independently of the movement of another fiber;

the improvement comprising,

(a) a reservoir under essentially ambient pressure containing substrate in which said fibers are immersed;

36

(b) a pump to withdraw permeate from within said fibers; and,

(c) an air distribution means within said skein said air distribution means including through-passages for bubbles which contact said fibers.

28. The device of claim 27 wherein through-passages are within said skein.

29. The device of claim 28 including in addition, air-tubes on either side of a skein providing sufficient air to cleanse said skein having less than about 30 arrays of fibers between said air-tubes.

* * * * *

UNITED STATES PATENT AND TRADEMARK OFFICE
CERTIFICATE OF CORRECTION

PATENT NO. : RE 37,549 E
DATED : February 19, 2002
INVENTOR(S) : Mailvaganam Mahendran et al.

Page 1 of 1

It is certified that error appears in the above-identified patent and that said Letters Patent is hereby corrected as shown below:

The present reissue patent issued from an application that is one of a family of divisional reissue applications resulting from Patent No. 5,639,373. The present reissue patent has issued without the cross reference to the other reissue application(s) of the family which is required pursuant to 37 CFR 1.177(a).

Title page,

Insert item -- [*] Notice: More than one reissue application has been filed for the reissue of patent 5,639,373. The reissue applications are 09/333,669 and 09/975,220. --

Column 1,

Under the title insert: -- Application 09/975,220 filed October 11, 2001, and co-pending application 09/033,669 filed June 15, 1999, are each reissues of U.S. Patent No. 5,639,373. --

Signed and Sealed this

Twenty-fifth Day of November, 2003

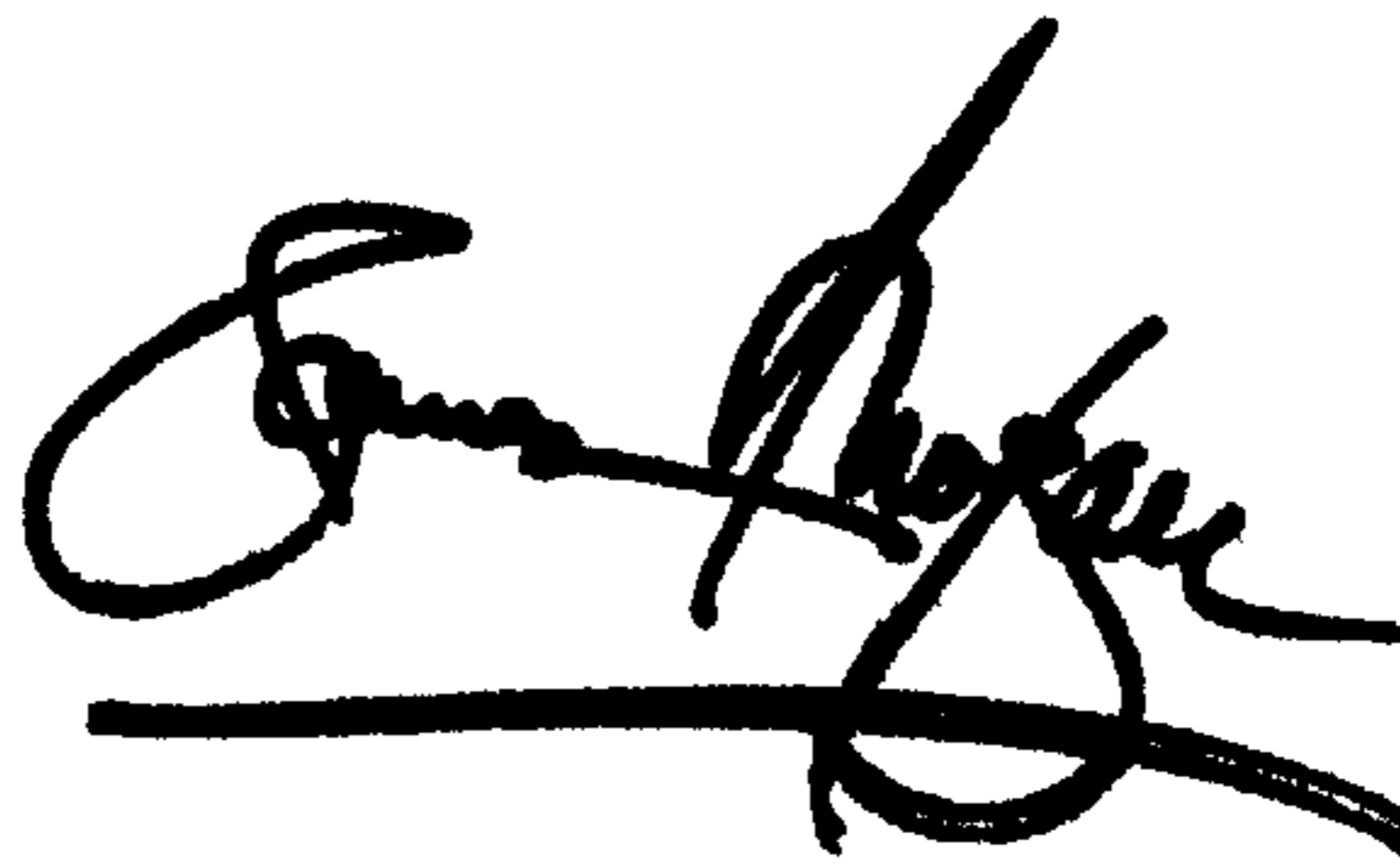
A handwritten signature in black ink, appearing to read "James E. Rogan", written over a horizontal line.

JAMES E. ROGAN
Director of the United States Patent and Trademark Office