



US00RE37528E

(19) **United States**
(12) **Reissued Patent**
Hannaford et al.

(10) **Patent Number: US RE37,528 E**
(45) **Date of Reissued Patent: Jan. 22, 2002**

(54) **DIRECT-DRIVE MANIPULATOR FOR PEN-BASED FORCE DISPLAY**

FOREIGN PATENT DOCUMENTS

(75) Inventors: **Blake Hannaford**, Seattle, WA (US);
Pietro Buttolo, Dearborn, MI (US)

JP	4-34610	2/1992
WO	WO9426167	11/1994
WO	WO9520787	8/1995
WO	WO9532459	11/1995

(73) Assignee: **Immersion Corporation**, San Jose, CA (US)

OTHER PUBLICATIONS

(21) Appl. No.: **09/110,370**

Millman et al., "Design of a Four Degree-of-Freedom Force-Reflecting Manipulandum with a Specified Force/Torque Workspace", Proceedings of 1991 IEEE INT'l Conf on Robotics & Auto, Apr. 1991.*

(22) Filed: **Jun. 30, 1998**

Ramstein et al., "The Pantograph: A Large Workspace Haptic Device For A Multimodal Human-Computer Interaction".*

Related U.S. Patent Documents

"The Phantom Force-Reflecting Interface", Senable Devices Inc.*

Reissue of:

(64) Patent No.: **5,642,469**
Issued: **Jun. 24, 1997**
Appl. No.: **08/334,621**
Filed: **Nov. 3, 1994**

(List continued on next page.)

- (51) **Int. Cl.**⁷ **G05B 15/00**
- (52) **U.S. Cl.** **700/264; 345/179; 345/161; 318/568.11**
- (58) **Field of Search** **700/188, 264; 345/161, 156, 157, 163, 167, 146, 145, 158, 339, 179; 318/500, 568.11, 568.17, 568.19, 568.23; 463/30, 38**

Primary Examiner—William Grant
Assistant Examiner—Chad Rapp
(74) *Attorney, Agent, or Firm*—James R. Riegel

(56) **References Cited**

ABSTRACT

U.S. PATENT DOCUMENTS

- 3,490,059 A 1/1970 Paulsen et al. 73/862.043
- 3,795,150 A 3/1974 Eckhardt 74/5.4
- 3,875,488 A 4/1975 Crocker et al. 318/648
- 3,919,691 A 11/1975 Noll 345/419
- 4,148,014 A 4/1979 Burson 345/161
- 4,216,467 A 8/1980 Colston 341/20
- 4,398,889 A 8/1983 Lam et al. 434/45
- 4,436,188 A 3/1984 Jones 188/378
- 4,477,043 A 10/1984 Repperger 244/223
- 4,638,798 A 1/1987 Shelden et al. 606/130
- 4,653,011 A 3/1987 Iwano 700/258
- 4,775,289 A 10/1988 Kazerooni 414/735
- 4,795,296 A * 1/1989 Jan 414/5

A pen-based direct-drive manipulator enables precision manipulation and force display of a control point within three degrees of freedom. The control point exhibits substantially no backlash, very low friction and very low inertia making it useful as a force display. The manipulator also has a very high force generation bandwidth allowing high frequency force components to be displayed. A parallel actuator structure controls motion over two degrees of freedom in a horizontal plane. The parallel structure is a redundant structure including three chains in parallel coupled at the control point. The redundant structure provides a uniform force capability throughout the manipulator workspace. A pair of rotational actuators rotate the parallel structure about an axis to approximate a linear motion along a third axis. The rotational actuators provide a third degree of freedom for the control point. Motion about the third axis is substantially decouple from motion about the horizontal plane.

(List continued on next page.)

29 Claims, 3 Drawing Sheets

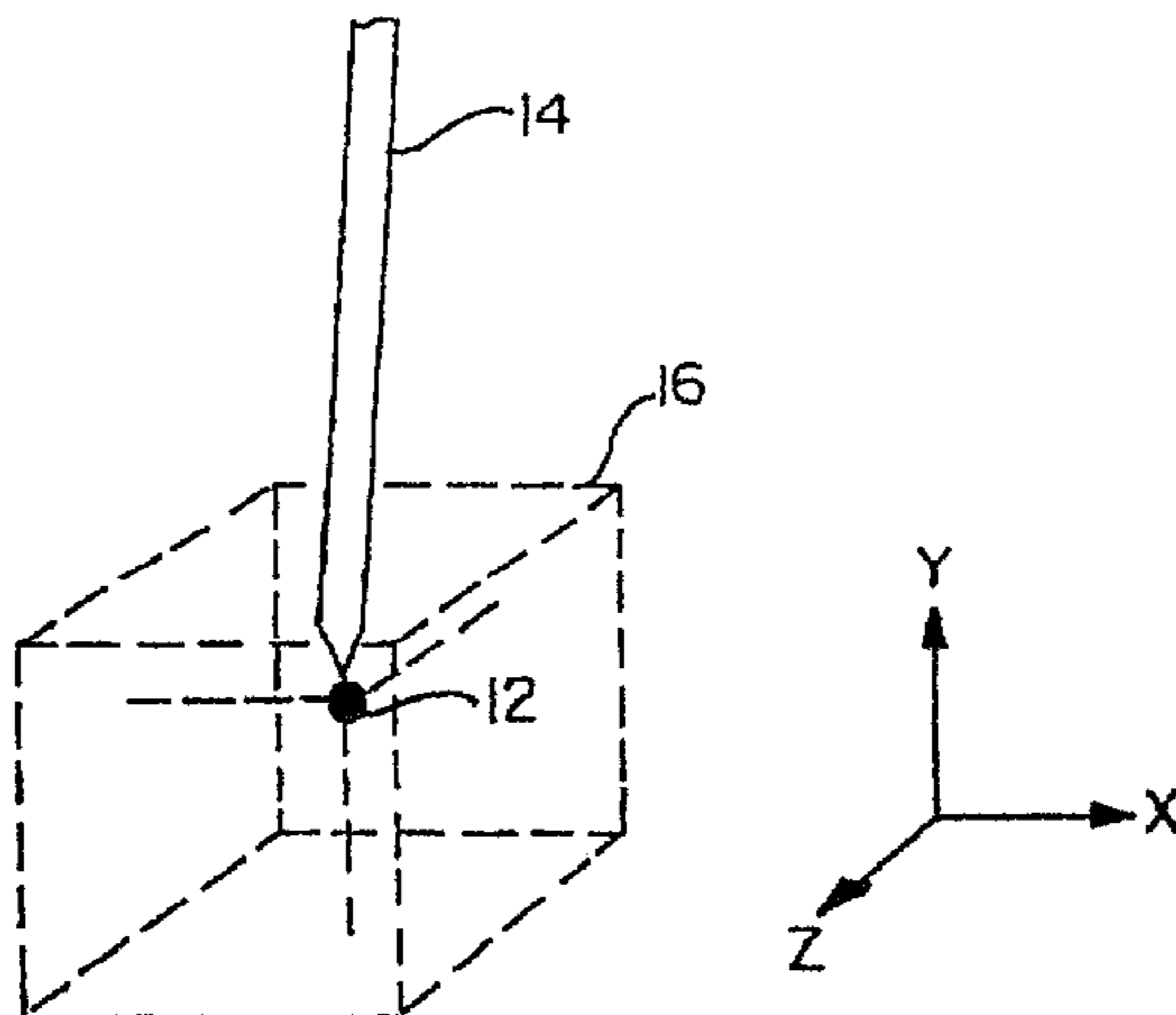

U.S. PATENT DOCUMENTS

4,800,721 A	1/1989	Cemenska et al.	60/393
4,803,413 A	2/1989	Kendig et al.	318/648
4,811,608 A	3/1989	Hilton	73/862.04
4,879,556 A	11/1989	Duimel	341/20
4,907,970 A	3/1990	Meenen, Jr.	434/45
4,961,267 A	10/1990	Herzog	33/503
4,962,448 A	10/1990	DeMaio et al.	364/146
5,004,391 A *	4/1991	Burdea	414/6
5,007,300 A	4/1991	Siva	74/471 XY
5,044,956 A	9/1991	Behensky et al.	434/45
5,072,361 A *	12/1991	Davis et al.	700/66
5,103,404 A	4/1992	McIntosh	318/568.22
5,107,080 A	4/1992	Rosen	200/6 A
5,142,931 A	9/1992	Menahem	74/471 XY
5,143,505 A	9/1992	Burdea et al.	414/5
5,184,319 A	2/1993	Kramer	345/500.26
5,185,561 A	2/1993	Good et al.	318/432
5,193,963 A	3/1993	McAffee et al.	414/5
5,201,838 A *	4/1993	Roudaut	294/88
5,223,776 A	6/1993	Radke et al.	318/568.1
5,228,356 A	7/1993	Chuang	74/471 XY
5,231,693 A *	7/1993	Backes et al.	700/264
5,264,768 A	11/1993	Gregory et al.	318/561
5,266,875 A *	11/1993	Slotine et al.	318/568.11
5,267,956 A *	12/1993	Beuchat	604/30
5,289,273 A	2/1994	Lang	348/121
5,296,846 A	3/1994	Ledley	345/161
5,297,057 A	3/1994	Kramer et al.	345/500.28
5,382,885 A *	1/1995	Salcudean et al.	318/568.11
5,389,865 A	2/1995	Jacobus et al.	318/568.11
5,397,323 A	3/1995	Taylor et al.	606/130
5,410,638 A *	4/1995	Colgate et al.	700/264
5,414,337 A	5/1995	Schuler	318/561
5,436,640 A	7/1995	Reeves	345/161
5,491,477 A	2/1996	Clark et al.	341/20
5,513,100 A	4/1996	Parker et al.	700/56
5,524,180 A *	6/1996	Wang et al.	600/118
5,576,727 A	11/1996	Rosenberg et al.	345/179
5,589,854 A	12/1996	Tsai	345/161
5,591,924 A	1/1997	Hilton	73/862.043
5,623,582 A	4/1997	Rosenberg	700/264
5,625,576 A	4/1997	Massie et al.	395/500.27
5,643,087 A	7/1997	Marcus et al.	463/38
5,709,219 A	1/1998	Chen et al.	600/595
5,731,804 A	3/1998	Rosenberg	345/156
5,734,373 A *	3/1998	Roenberg et al.	345/161
5,742,278 A	4/1998	Chen	345/156
5,755,577 A	5/1998	Gillio	434/262
5,767,839 A	6/1998	Rosenberg	345/161
5,769,640 A	7/1998	Jacobus et al.	434/262
5,790,108 A	8/1998	Salcudean et al.	345/184
5,805,140 A	9/1998	Rosenberg et al.	345/161
5,808,665 A *	9/1998	Green	348/65
5,825,308 A *	10/1998	Rosenberg	341/20
5,828,197 A	10/1998	Martin et al.	318/567
6,004,134 A	12/1999	Marcus et al.	434/45
6,024,576 A	2/2000	Bevirt et al.	434/262

OTHER PUBLICATIONS

Wong et al., "A Force Reflecting Teleoperation System with Magnetically Levitated Master and Wrist", Proceedings of 1992 IEEE INT'l Conf. on Robotics and Automation; France May 1992.*

Bostrom et al., "Design of an Interactive Lumbar Puncture Simulator with Tactile Feedback", IEEE Pub #0-7803-1363, Jan. 1993.*

Hirota et al., "Development of Surface Display", IEEE Pub. No. 0-7803-1363, Jan. 1993.*

Magic Mouse: Tactile and Kinesthetic Feedback in the Human-Computer Interface using an Electromagnetically Actuated Input/Output Device, Oct. 1993.*

Hayward, V. et al., "Design and Multi-Objective Optimization of a Linkage for a Haptic Interface," *Advances in Robot Kinematics and Computed Geometry*, 1994, pp. 359-368

Buttolo et al., "Hard Disk Actuators for Mini Teleoperation," Proceedings SPIE, Telemanipulator and Telepresence Technologies Symposium, pp. 55-61, Oct. 1994.

Ouh-Young, Ming, "Force Display in Molecular Docking," Chapel Hill 1990, pp. 1-85.

Ellis, R.E. et al., "Design and Evaluation of a High-Performance Prototype Planar Haptic Interface," ASME Dec. 3, 1993, DSC-Vol. 49, pp. 55-64.

Adelstein, B. et al., "A High Performance Two Degree-of-Freedom Kinesthetic Interface," pp. 108-112.

Fischer, Patrick et al., "Specification and Design of Input Devices for Teleoperation," 1990.

Adachi et al., "Sensory Evaluation of Virtual Haptic Push-Buttons," Technical Research Center, Suzuki Motor Corp., Nov. 1994.

Tan, Hong Z et al., "Manual Resolution of Compliance When Work and Force Cues are Minimized," ASME 1993, DSC-vol. 49, pp. 99-104.

Iwata, Hiroo, "Pen-based Haptic Virtual Environment," Institute of Engineering Mechanics, University of Tsukuba, Japan, pp. 287-292.

Howe, Robert D., "Task Performance with a Dextrous Teleoperated Hand System," Proceedings of SPIE, Nov. 1992, vol. 1833, pp. 1-9.

Schmult, Brian et al., "Application Areas for a Force-Feedback Joystick," ASME 1993, DSC-vol. 49, pp. 47-54.

Winey III, Calvin Mccoy, "Computer Simulated Visual and Tactile Feedback as an Aid to Manipulator and Vehicle Control," MIT, Jun. 1981.

Kilpatrick, Paul Jerome, "The Use of a Kinesthetic Supplement in an Interactive Graphics System", University of North Carolina at Chapel Hill, 1976.

Iwata, Hiroo, "Artificial Reality with Force-feedback", Computer Graphics vol. 24, No. 4, Aug. 1990.

Slocum, Alexander, "Precision Machine Design," Prentice Hall, New Jersey, 1992, pp. 661-664.

Minsky, Margaret et al., "Feeling and Seeing: Issues in Force Display," ACM 1990, pp. 235-242.

Brooks, Jr., et al., "Project Grope—Haptic Displays for Scientific Visualization," Computer Graphics, vol. 24, No. 4, Aug. 1990, pp. 177-185.

Rosenberg, Louis B., "Virtual Haptic Overlays Enhance Performance in Telepresence Tasks," SPIE 1994.

Adelstein, Bernard D. et al., "Design and Implementation of a Force Reflecting Manipulandum for Manual Control Research," 1992, pp. 1-24.

Atkinson, William D. et al, "Computing with Feeling," Comput. & Graphics vol. 2, No. 2-E, pp. 97-103.

Noll, A. Michael, "Man-Machine Tactile Communication Dissertation," Polytechnic Institute of Brooklyn, Jun. 1971, pp. 1-88.

Tavkheldze, D.S. et al., "Kinematic Analysis of Five-Link Spherical Mechanisms," Mechanism and Machine Theory, Pergamon Press, 1974, pp. 181-190.

Jacobsen, S.C. et al., "High Performance, High Dexterity, Force Reflective Teleoperator II," ANS Topical Meeting on Robotics & Remote Systems, Albuquerque, New Mexico Feb. 24-27, 1991, pp. 1-10.

Iwata, Hiroo et al, Volume Haptization, IEEE 1993, pp. 16-18.

Rosenberg, Louis B., "The Use of Virtual Fixtures to Enhance Operator Performance in Time Delayed Teleoperation", Armstrong Laboratory, Mar. 1993, pp. 1-45.

Rosenberg, Louis B., "Perceptual Design of a Virtual Rigid Surface Contact," Center for Design Research Stanford University, Air Force Material Command, Apr. 1993, pp. 1-41.

Snow, E. et al., "Compact Force-Reflecting Hand Controller," JPL, Apr. 1991, vol. 15, No. 3, Item No. 153, pp. 1-15a.

McAfee, Douglas A., "Teleoperator System/Telerobot Demonstrator: Force Reflecting Hand Controller Equipment Manual," JPL Jan. 1988, pp. 3-8, 11, and A-34.

Russo, Massimo Andrea, "The Design and Implementation of a Three Degree-of-Freedom Force Output Joystick," Department of Mechanical Engineering, May 11, 1990, pp. 9-40 & 96 & 97.

* cited by examiner

FIG. 1

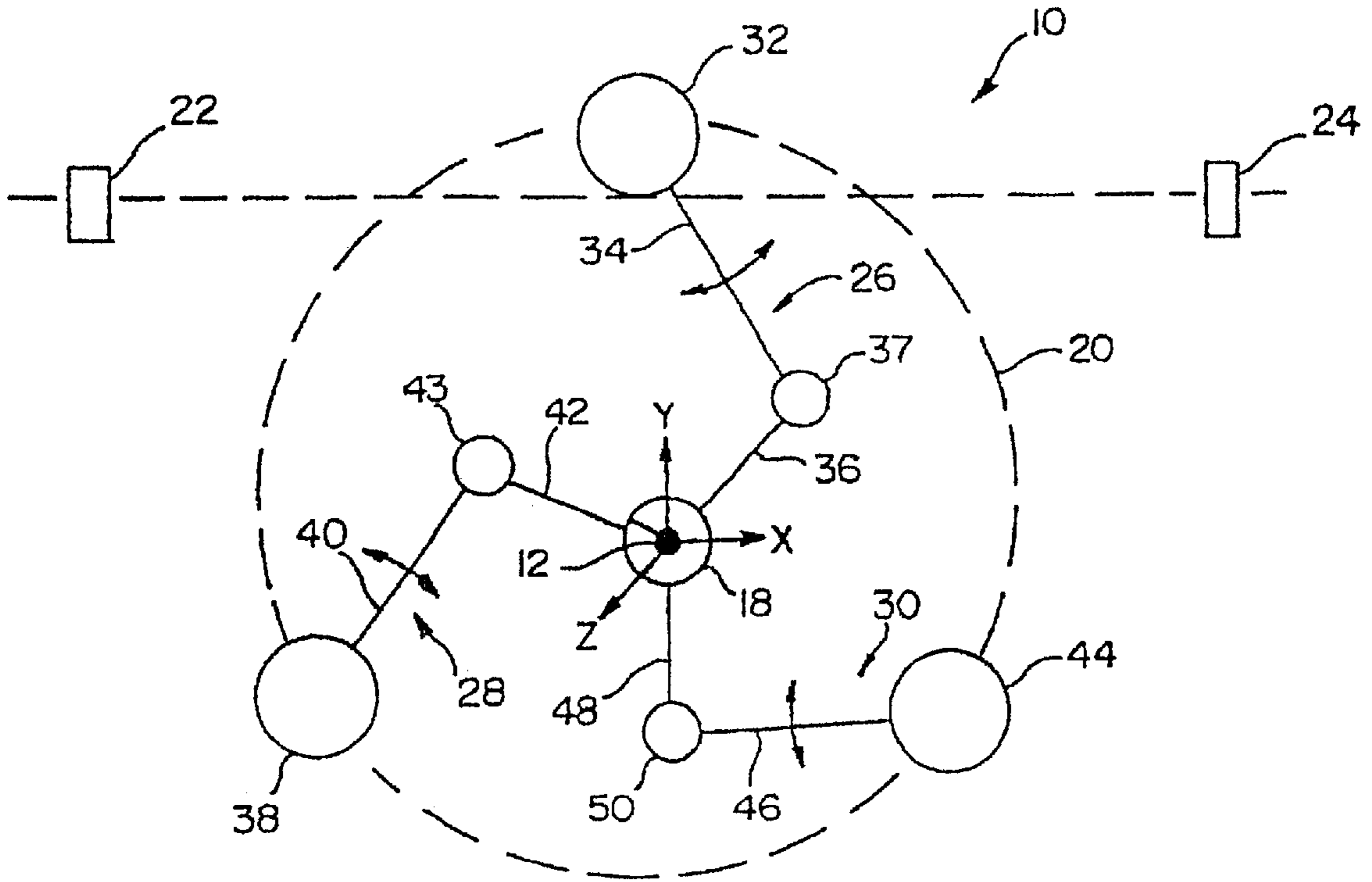
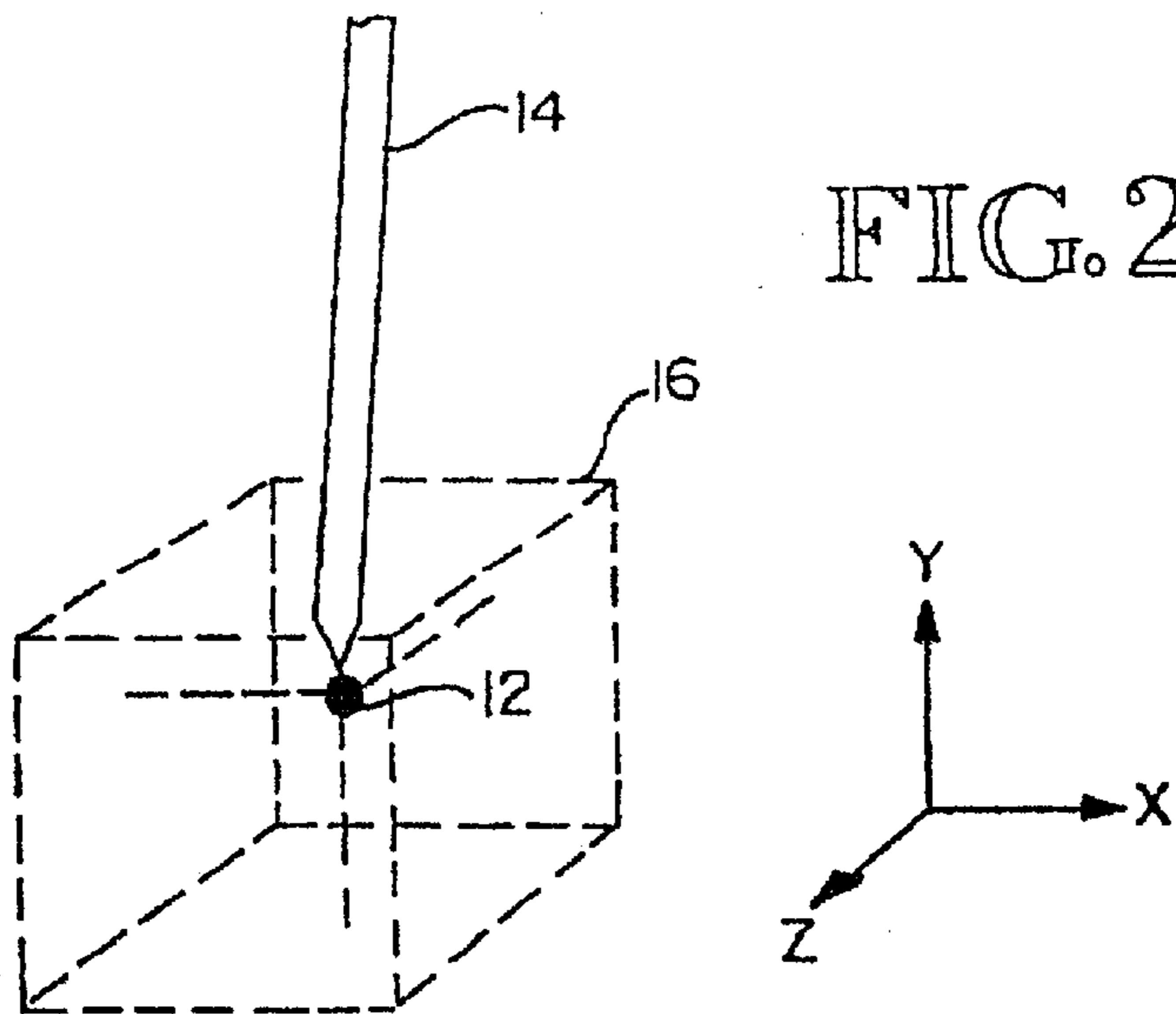

FIG. 2



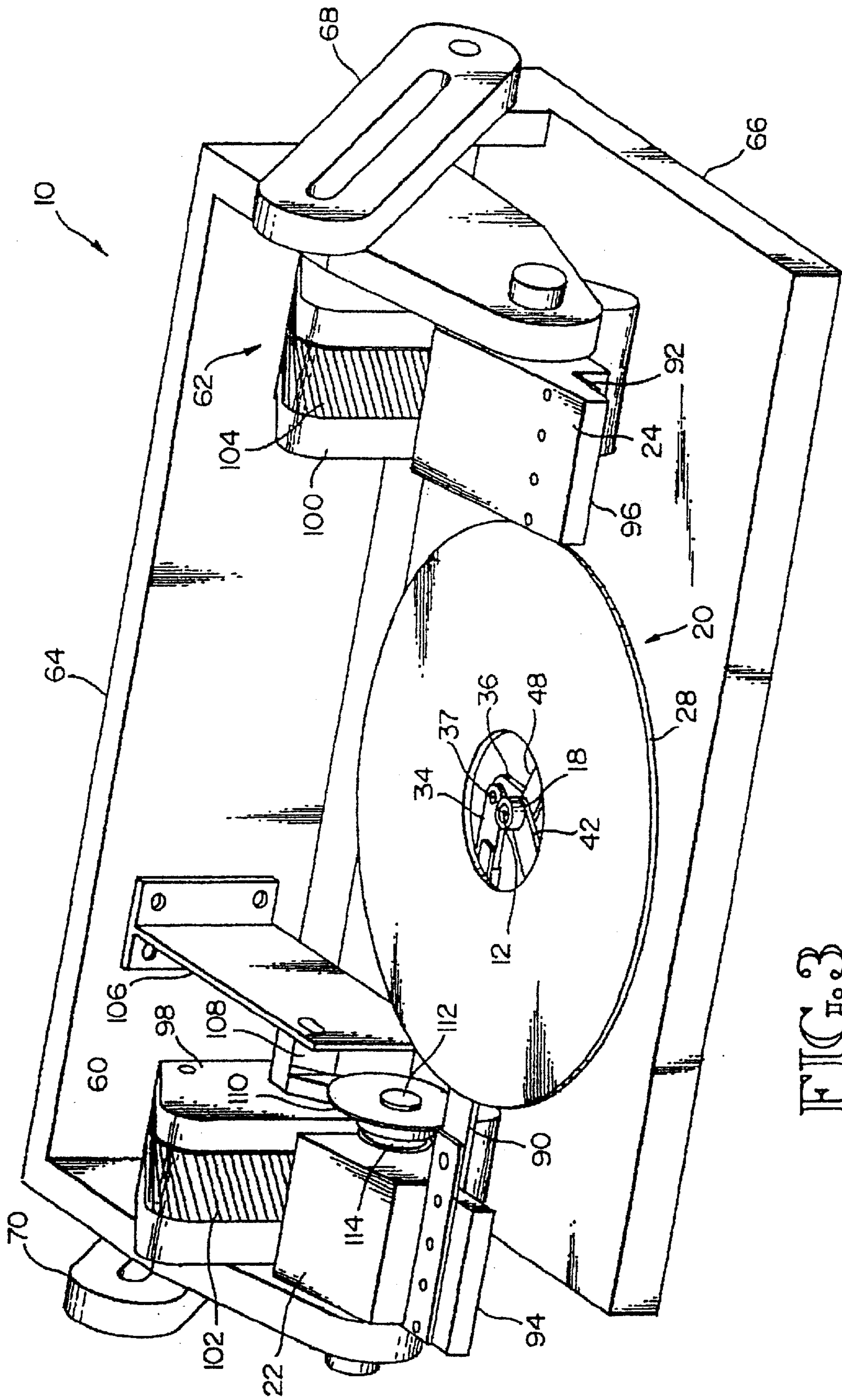

FIG. 3

FIG. 4

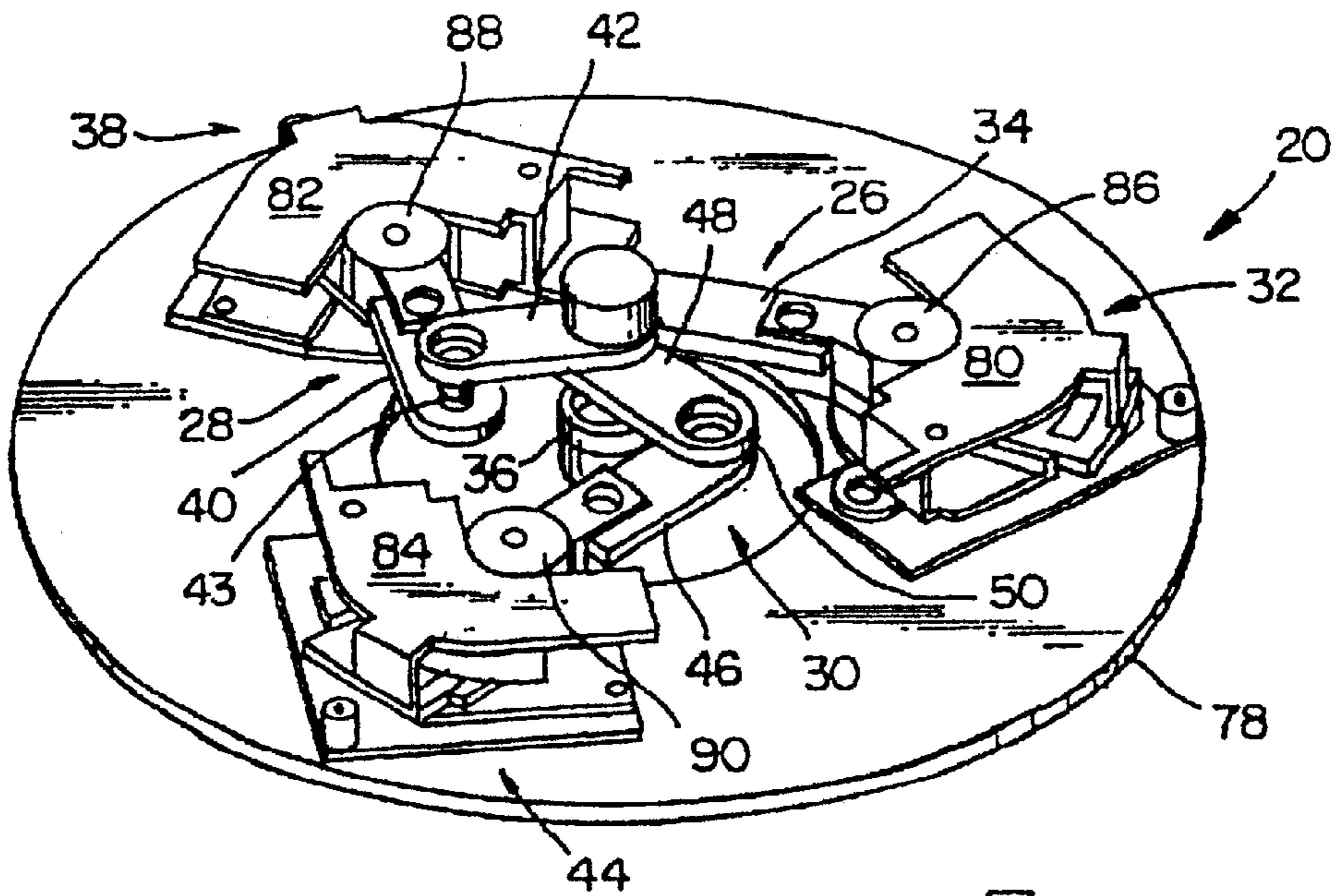
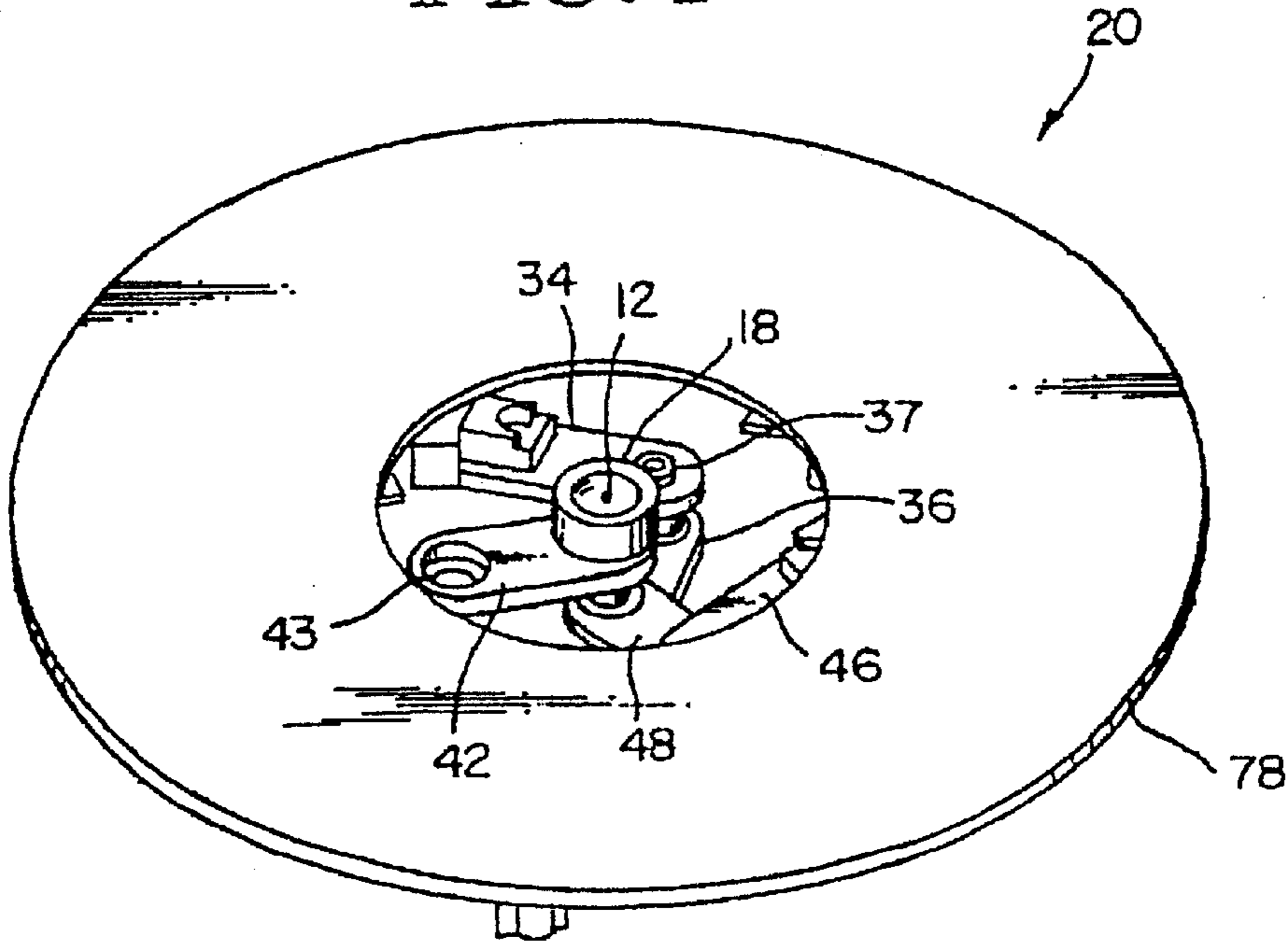

FIG. 5

DIRECT-DRIVE MANIPULATOR FOR PEN-BASED FORCE DISPLAY

Matter enclosed in heavy brackets [] appears in the original patent but forms no part of this reissue specification; matter printed in italics indicates the additions made by reissue.

FEDERAL FUNDING AGREEMENT

This invention was made with government support under grant number BCS 9058408 awarded by the National Science Foundation. The government has certain rights in the invention.

BACKGROUND OF THE INVENTION

This invention relates to direct-drive manipulators and force feedback devices. More particularly this invention relates to a direct-drive manipulator having three degrees of freedom and suitable for use as a pen-based force display for a virtual reality or telerobotic environment.

A manipulator can serve as an input device for controlling movement of a robot or other real or simulated device. A direct drive manipulator responds to operator manipulations using one or more actuators directly coupled to a load (on the output side) or an operator contact point (on the input side). This contrasts with an indirectly driven manipulator which responds to operator manipulations using one or more actuators indirectly coupled to the load or operator contact point through gears or other scaling devices.

A pen-based manipulator is characterized by an elongated member having a contact point for applying operator input forces and displacements. The manipulator enables an operator holding the elongated member to move the member within a workspace under the control of manipulator components (e.g., actuators, joints and links).

A force feedback device is characterized as an output device in which forces are applied to an operator holding the feedback device. In several telerobotic applications, for example, a master manipulator located away from a robot controls a slave manipulator located at the robot. The master manipulator serves as an input device for commanding movement of the robot via forces or displacements applied to the manipulator by an operator. In addition, the master manipulator sometimes serves as a force feedback device for exhibiting force sensations felt by the operator. In a force reflection application, for example, the forces encountered by the robot under control are reflected back to the operator at the manipulator to enable improved coordination of robot motion and dexterity. U.S. Pat. No. 5,072,361 (Davis et al.) discloses a force-reflective tele-operation control system in which a master station includes an actuator exhibiting force resistance to movement in a master link. Such resistance is to be comparable to the resistance encountered by a slave device so that movement of the master device by an operator tracks movement of the slave device being controlled.

A force feedback device also is referred to as a force display. In the computer field the term display refers to a visual output device upon which ephemeral images are shown. The display serves as a visual interface between an end user and a computer environment. An operator uses his visual sense to experience the images. Analogously, the term "force display" is coined to refer to an output device upon which ephemeral forces are exhibited. The force display serves as a force-reflective, haptic, kinaesthetic, or tactile interface between an operator and a real or simulated environment. The operator uses his sense of touch to experience

the forces. The force display, however, typically is more than a display in that it also serves as an input device. A force display is a bidirectional mechanical interface through which an operator both applies and receives forces and displacements.

SUMMARY OF THE INVENTION

According to the invention, a direct-drive manipulator enables precision manipulation and force display at a control point. By using a pen-like or other end-effector an operator applies forces to the control point. The manipulator responds to the applied forces allowing movement of the control point within a workspace domain over three degrees of freedom. When combined with a controller implementing a control algorithm for a specific application environment, force sensations are reflected back to the control point to be experienced by the operator. Virtual reality, telerobotic, and other simulated, real or remote applications can be created to define a control algorithm. For example, a control algorithm may define immovable object shapes. An operator then is able to trace the virtual object shapes and feel the object boundaries. In another example, a control algorithm may define tissue having shape, texture and force resistance variables at different locations. An operator then may perform a virtual reality surgery, in which the control point is the cutting point of a scalpel. Depending on the position of the control point and force applied, the operator experiences the sensation of cutting through the virtual tissue. In a telerobotic application for remotely controlling a robot, the control algorithm is defined as a reflection of forces encountered by the robot. There are many other examples of a control algorithm that could be created to use with the manipulator. This invention is directed toward the manipulator with control point to be used as a force display.

To serve as a force display it is desirable that the manipulator have substantially no backlash, very low friction, and very low inertia. Backlash, friction and inertia detract from a natural feel of a control point. No matter how sophisticated a control algorithm, if the manipulator suffers from significant amounts of backlash, friction or inertia, then its use as a force display is compromised. It also is desirable that the manipulator have a high bandwidth so that high frequency force components can be displayed.

According to one aspect of the invention, direct drive actuators are used for the manipulator. Direct drive actuators have force display advantages over indirect drive actuators. Indirect drive geared actuators have unacceptable backlash and friction characteristics. Also, indirect drive actuators typically have lower bandwidth capability. Direct drive actuators are implemented here in a configuration for a control point having no backlash, very low friction and very high force generation bandwidth.

According to another aspect of the invention, a parallel actuator structure is used to control motion in a horizontal plane to achieve very low inertia of the control point. The parallel structure provides two degrees of freedom in a horizontal plane of motion.

According to another aspect of the invention, the parallel structure is a redundant structure including three chains in parallel coupled at the control point. Each chain includes an actuator and two links. Each actuator is positioned at a fixed origin. One end of an inner link is coupled to the actuator. An opposite end of the inner link is coupled to one end of an outer link. A joint is formed at the connection of the inner and outer links. The opposite end of the outer link is coupled to the control point. The three chains define a planar

structure in which three actuators provide two degrees of freedom with redundancy.

The parallel redundant (3-chain) structure of this invention improves over prior parallel 2-chain structures by enabling a more uniform force capability throughout the manipulator workspace. In the workspace of a conventional 2-chain structure the maximum force that can be applied to a control point varies depending on where the control point currently is positioned. According to the 3-chain structure of this invention, however, the maximum force that can be applied is substantially uniform throughout the workspace.

According to another aspect of the invention redundant sensing also is performed by including a sensor at each actuator in the parallel structure. Redundant sensing enables more uniform high resolution position sensing throughout the workspace.

According to another aspect of the invention the end-effector defines an open tool interface point as the control point. An operator holds his finger, a pen-like tool or other tool to the interface point and applies forces or displacements to manipulate the control point. By providing an open interface there is no friction or backlash introduced by a device that would hold the tool tip in place at the control point. Similarly the operator can apply or remove the tool from the control point with a natural feel. For example if the tool is a scalpel in a surgical virtual reality application, the trainee physician can manipulate the scalpel as during a real operation, then apply the scalpel to the control point to perform a cutting/surgical maneuver. The operator therefore achieves a more realistic making and breaking of contact.

According to another aspect of the invention, a pair of rotational actuators rotate the parallel structure about an axis to approximate a linear motion along a third axis, and provide a third degree of freedom for the control point.

One advantage of the manipulator of this invention is that embodiments have substantially no backlash, very low friction, very low inertia and a very high force generation bandwidth enabling a natural feel when implemented as a force display. Another advantage is that embodiments have a substantially uniform force capability throughout their workspace. These and other aspects and advantages of the invention will be better understood by reference to the following detailed description taken in conjunction with the accompanying drawings.

BRIEF DESCRIPTION OF THE DRAWINGS

FIG. 1 is a schematic diagram of the pen-based direct-drive manipulator according to an embodiment of this invention;

FIG. 2 is a diagram of the control point and workspace for the manipulator of FIG. 1 with a pen-like tool used by an operator;

FIG. 3 is a perspective view of the pen-based direct-drive manipulator according to an embodiment of this invention;

FIG. 4 is a perspective view of the planar assembly portion of the manipulator of FIG. 1 which defines two degrees of freedom; and

FIG. 5 is another perspective view of the planar assembly portion of the manipulator of FIG. 1 which defines two degrees of freedom; and

DESCRIPTION OF SPECIFIC EMBODIMENTS

Overview

FIG. 1 shows a schematic diagram of the pen-based direct-drive manipulator **10** according to one embodiment of

the invention. The function of the manipulator **10** is to enable precision manipulation and force display at a control point **12**. Referring to FIG. 2, an operator uses a pen-like or other tool **14** to apply forces/displacements to the control point **12**. The manipulator **10** responds to the applied forces allowing control point **12** movement with three degrees of freedom within a workspace **16**. The control point **12** is defined at an end-effector **18**. The manipulator **10** includes a planar structure **20** enabling motion in an xy plane to define two degrees of freedom. The planar structure **20** is moved along a z-axis by actuators **22**, **24** to define a third degree of freedom.

FIG. 3 shows an assembled direct-drive manipulator **10** according to an embodiment of this invention. The manipulator includes a planar assembly **20** mounted to rotational actuation assemblies **60**, **62**. The rotational actuation assemblies **60**, **62** are mounted to a yoke plate **64**. The yoke plate is adjustably mounted to a base plate **66** via links **68**, **70**. The base plate **66** rests on a surface. The yoke plate **64** is adjustable relative to the base plate **66** to provide a desirable position and orientation to the planar assembly **20**. For a given application an operator may prefer the xy plane to have a specific position and orientation relative to the operator's tool **14**. By adjusting the yoke plate relative to the base **66** a desired orientation is achieved. In an alternative embodiment, the rotational actuation assemblies **60**, **62** are replaced with vertical actuation assemblies. As implemented in the embodiment shown, the rotational assemblies generate motion approximating vertical motion along the z-axis of workspace **16**.

Planar Actuation Structure

Referring to FIGS. 1, 4 and 5, the planar structure **20** is a parallel, redundant actuator assembly, including three chains **26**, **28**, **30** in parallel coupled at an end effector **18**. Each chain includes an actuator and two links. A first chain **26** includes an actuator **32**, inner link **34** and outer link **36**. A joint **37** is formed between the inner link **34** and outer link **36**. A second chain **28** includes an actuator **38**, inner link **40** and outer link **42**. A joint **43** is formed between the inner link **40** and outer link **42**. A third chain **30** includes an actuator **44**, inner link **46** and outer link **48**. A joint **50** is formed between the inner link **46** and outer link **48**. Low friction ball bearings, washers and rigid connecting axes are included at joints **37**, **43** and **50** and where outer links **36**, **42**, **48** couple to the end effector **18**. Each actuator **32**, **38**, **44** is fixed relative to the planar structure **20**, and thus, relative to the xy plane.

Referring to FIGS. 4 and 5 the chains **26**, **28**, **30** are mounted to a rigid disk **78** having a planar surface. In one embodiment the disk **78** is the media disk of a 3.5 inch hard disk drive. The inner links **34**, **40**, **46** and outer links **36**, **42**, **48** are machined from 3.5 inch hard disk drive media. Also, each actuator **32**, **38**, **44** is a direct drive actuator like those used in computer hard disk drives, such as a 1.8 inch hard disk drive. Each actuator **32**, **38**, **44** structure is implemented as a direct drive actuator and includes a flat coil, magnet, encoder, encoder base, codewheel, codewheel screw and codewheel base. Encoder bases **86**, **88**, **90** are shown. In an alternative embodiment, the planar structure **20** includes redundant actuators (e.g., 3), but not redundant encoders, (e.g., only two are used). In one embodiment the codewheels are Hewlett Packard codewheel part no. HEDM-5120-J03 and the encoders are Hewlett Packard encoder module part no. HEDS-9100-J00. The magnets and flat coils are from a 1.8 inch hard disk drive and the magnet frames **80**, **82**, **84** are machined from a 1.8 inch hard disk drive frame. Although 3.5 inch and 1.8 inch hard disk drive scaling is used on the

described embodiment, the components may be scaled to larger or smaller dimension to increase or decrease the workspace **16** (see FIG. **2**). In addition other types of actuators may be used. Preferably the actuators have low friction, low inertia and substantially no backlash.

Rotational Actuation Structure

Referring again to FIG. **3** the rotational actuation structures **60, 62** are shown. The planar structure **20** is coupled to the rotational actuation structures **60, 62** at fixed links **90, 92**. The links **90, 92** are mounted to respect rotational actuator frames **94, 96**. In one embodiment the frames **94, 96** are moved by 5.25 inch hard disk drive flat coil and magnet assemblies which serve as actuators **22, 24**. Magnets **98, 100** and flat coils **102, 104** are shown. An encoder module is formed by encoder module base **106**, encoder **108**, code-wheel **110**, codewheel screw **112**, codewheel base **114** and washers. In one embodiment the codewheel is a Hewlett Packard codewheel part no. HEDM-5120-J03 and the encoder is a Hewlett Packard encoder module HEDS-9100-J00. Although 5.25 inch hard disk drive scaling is used on the described embodiment, the components may be scaled to larger or smaller dimension to increase or decrease the workspace **16** (see FIG. **2**). In the described embodiment, the rotational actuation structures **60, 62** define motion approximating vertical motion along the z axis of the workspace domain. If the vertical dimension of the workspace is desired to be increased outside the range of the vertical approximation, then the motion in the z direction is coupled to the motion in the x and y directions. In the preferred embodiment such motions are substantially decoupled.

Kinematic Characteristics

The manipulator **10** enables movement of a control point **12** within a workspace **16** over three degrees of freedom. Two degrees of freedom are provided by the planar actuation structure **20** allowing motion within an xy plane. A third degree of freedom is provided by the rotational actuation structures **60, 62** allowing motion along a z-axis. The workspace of the described embodiment is approximately 2 cm×2 cm×2 cm. For the rotational actuators **20, 22** this represents approximately ±20°. Over such rotation, the rotary motion is approximated as linear motion along the z-axis. By approximating the motion as linear, the planar xy motion and the vertical z motion are substantially decoupled allowing for simpler kinematic modelling and simpler control algorithms.

In the following static and dynamic equations of the manipulator **10**, the following notations are used:

${}^i\Theta_1$ =angle of inner link in i-th serial chain
 ${}^i\Theta_2$ =angle of outer link in i-th serial chain
 ${}^i\Theta_{12}={}^i\Theta_1+{}^i\Theta_2$
 ${}^i x_o, {}^i y_o$ =position of origin of i-th serial chain in xy plane
 ${}^i x_{in}, {}^i y_{in}$ =position of intermediate joint in i-th serial chain in xy plane

x_e, y_e =position of end effector in xy plane

z_e =vertical position of end effector

Also, in one embodiment, the following manipulator parameters are implemented:

l_1 =length of inner link for each serial chain=2 cm

l_2 =length of outer link for each serial chain=1.25 cm

l =length between the origins of a first and a second actuator in the planar actuating structure=4.05 cm

l_z =displacement of end effector from the z-axis=2 cm

Position of end effector:

Because the motions in the xy plane are substantially decoupled from the motion along the z-axis, x_e, y_e is independent of z_e . The end effector position in the xy plane is:

$$\begin{bmatrix} x_e \\ y_e \end{bmatrix} = R \begin{bmatrix} dtxdir \\ dtydir \end{bmatrix} + \begin{bmatrix} {}^1x_{in} \\ {}^1y_{in} \end{bmatrix}$$

where, R=frame rotation and more specifically

$$R = \begin{bmatrix} ({}^2x_{in} - {}^1x_{in}) & ({}^2y_{in} - {}^1y_{in}) \\ ({}^2y_{in} - {}^1y_{in}) & -({}^2x_{in} - {}^1x_{in}) \end{bmatrix} / l_{endir}$$

$$dtxdir = l_{endir} / 2$$

$$dtydir = \pm \sqrt{l_z^2 - dtxdir^2}$$

$$l_{endir} = \sqrt{({}^2x_{in} - {}^1x_{in})^2 + ({}^2y_{in} - {}^1y_{in})^2}$$

The end effector position along the z-axis is:

$$z_e = l_z \sin \Theta_z \approx l_z \Theta_z$$

The position of the intermediate joints formed by the inner and outer links of a respective serial chain are:

$$({}^1x_{in}, {}^1y_{in}) = (-l_1 \cos ({}^1\Theta_1), -l_1 \sin ({}^1\Theta_1)) + ({}^1x_o, {}^1y_o)$$

$$({}^2x_{in}, {}^2y_{in}) = (-l_1 \cos ({}^2\Theta_1), -l_1 \sin ({}^2\Theta_1)) + ({}^2x_o, {}^2y_o)$$

$$({}^3x_{in}, {}^3y_{in}) = (-l_1 \cos ({}^3\Theta_1), -l_1 \sin ({}^3\Theta_1)) + ({}^3x_o, {}^3y_o)$$

The joint angles, ${}^i\Theta_1$, are defined as:

$${}^i\Theta_1 = \alpha \tan [({}^i y_{in} - {}^i y_o) / ({}^i x_{in} - {}^i x_o)] \text{ for } {}^i x_{in} - {}^i x_o \geq 0;$$

and

$${}^i\Theta_1 = \alpha \tan [({}^i y_{in} - {}^i y_o) / ({}^i x_{in} - {}^i x_o)] + \pi \text{ for } {}^i x_{in} - {}^i x_o < 0$$

The actuated link displacement and overall actuator displacements in the xy plane are given as:

$${}^i\phi_1 = \begin{bmatrix} \cos {}^i\Theta_{12} & \sin {}^i\Theta_{12} \\ l_1 \sin {}^i\Theta_2 & l_1 \sin {}^i\Theta_1 \end{bmatrix} \dot{x}_e$$

and

$$\vec{\Theta} = \begin{bmatrix} {}^1\phi_1 \\ {}^2\phi_1 \\ {}^3\phi_1 \end{bmatrix} = J_c^{-1}(\vec{\Theta}) \dot{x}_e$$

The force exerted on the end effector in the xy plane as a function of actuator displacements and torques is given as:

$$\vec{F}_e = J_c^{-\gamma}(\vec{\Theta}) \begin{bmatrix} \tau_1 \\ \tau_2 \\ \tau_3 \end{bmatrix}$$

The torque vector for the third degree of freedom is given as:

$$\tau_z = l_z(mg + F_z)$$

Dynamic Equations

At the end effector alone with no outside force applied, the equation of the i-th serial chain is:

$${}^i\tau = {}^iM({}^i\vec{\Theta}){}^i\ddot{\Theta} + {}^iV({}^i\vec{\Theta}, {}^i\dot{\Theta}) + {}^iG({}^i\vec{\Theta})$$

and in the cartesian frame is:

$$\bar{F}_e = {}^i M_e(\bar{\Theta}) \ddot{x}_e + {}^i V_e(\bar{\Theta}, \dot{\bar{\Theta}}) + {}^i G_e(\bar{\Theta})$$

Assuming the gravity force to be zero because the planar actuation structure works in the horizontal plane, the interaction forces between the chains are given as:

$${}^1 \bar{F}_e + {}^1 M_e(\bar{\Theta}) \ddot{x}_e = {}^1 V_e(\bar{\Theta}, \dot{\bar{\Theta}}) + \bar{F}_{21} + \bar{F}_{31}$$

$${}^2 \bar{F}_e + {}^2 M_e(\bar{\Theta}) \ddot{x}_e = {}^2 V_e(\bar{\Theta}, \dot{\bar{\Theta}}) + \bar{F}_{12} + \bar{F}_{32}$$

$${}^3 \bar{F}_e + {}^3 M_e(\bar{\Theta}) \ddot{x}_e = {}^3 V_e(\bar{\Theta}, \dot{\bar{\Theta}}) + \bar{F}_{13} + \bar{F}_{23}$$

where F_{ij} is the force exerted by the i -th serial chain on the j -th serial chain. Because the force are endogenous, they sum to zero:

$$F_{21} + F_{31} + F_{12} + F_{32} + F_{13} + F_{23} = 0$$

Adding together the three dynamic equations and considering an external force F_{ext} , we get the dynamic equations of the 2-dof planar actuating structure in the cartesian frame of reference:

$$\Sigma \bar{F}_e + \bar{F}_{ext} = \Sigma M_e(\Theta) \ddot{x}_e + \Sigma V_e(\Theta, \dot{\Theta})$$

The equation for the third degree of freedom is approximately:

$$\tau_z = l_z mg + l_z F_z + l_z \dot{\omega}_z$$

where $\dot{\omega}_z$ is the angular rotation of the Θ_z joint.

Actuation Redundancy

Because there are three actuators **32**, **38**, **44** providing two degrees of freedom, there are an infinite number of possible torque vectors that provide the same force. One approach is to select the torque vector that minimizes the energy spent by the serial chains **26**, **28**, **30**. A preferable approach is to choose the torque vector that maximizes the force that can be applied at the control point **12** (subject to actuator limits). Accordingly, the serial chains are controlled to move in response to external forces at the control point **12** in a manner that minimizes the following:

$$\max (|\tau_1|, |\tau_2|, |\tau_3|)$$

where τ_i is the torque magnitude of the i -th actuator in the planar structure **20**.

In one embodiment a given controller implements a simplex algorithm to identify $\max (|\tau_1|, |\tau_2|, |\tau_3|)$. Inputs are the end effector position x_e and the desired force F_e . The following steps then are performed:

Step 1: Calculate $J^{-T}(x_e(t_0))$;

Step 2: Calculate $\beta_1, \beta_2, \beta_3$, where

$$\beta_1 = (J^{-T}_{e11} F_{ey} - J^{-T}_{e21} F_{ex})$$

$$\beta_2 = (J^{-T}_{e12} F_{ey} - J^{-T}_{e22} F_{ex})$$

$$\beta_3 = (J^{-T}_{e13} F_{ey} - J^{-T}_{e23} F_{ex})$$

Step 3: Set $i3=1, i1=2, i2=3$;

Step 4: Calculate γ_{i1}, γ_{i2} , where

$$\gamma_{i1} = J^{-T}_{e(1,i1)} - J^{-T}_{e(1,i3)} (\beta_{i1}/\beta_{i3})$$

$$\gamma_{i2} = J^{-T}_{e(1,i2)} - J^{-T}_{e(1,i3)} (\beta_{i2}/\beta_{i3})$$

Step 5: Set $\gamma_{i1} = \text{sign}(Y_{i1}) \tau_{sat}, \text{sign}(Y_{i2}) \tau_{sat}$;

Step 6: Calculate τ_{i3} ; and

$$\gamma_{i3} = (\beta_{i1}/\beta_{i3}) \tau_{i1} + (\beta_{i2}/\beta_{i3}) \tau_{i2}$$

Step 7: If $|\tau_{i3}| \geq \tau_{sat}$ permute $i3=i2, i2=i1, i1=i3$ and start again from step 4.

The output solution is $\tau_{i1}, \tau_{i2}, \tau_{i3}$.

Experimental Results

In one embodiment, a manipulator **10** includes actuation structures machined in part from computer hard disk drive actuators. Characteristically these actuators have low inertia and low friction. Using 1.8" actuators for the planar actuation structure **20** and 5.25" actuators for the rotational actuating structures **60**, **62**, the following parameters were measured:

Steady state current at 120° C.: 1.8" actuators=0.65 A

5.25" actuators=0.52 A

Continuous torque that can be generated: 1.8" act=0.01

Nm 5.25" act.=0.06 Nm

Short term peak torque: for 1.8"=0.03 Nm (at 2 A) for

5.25"=0.24 Nm (at 2 A)

Serial chain parameters:

$l_1=2$ cm

$l_2=1.25$ cm

$l=4.05$ cm

$l_z=2$ cm

The mass of each inner link **34**, **40**, **46** is approximately $m=1.0$ grams. The mass of each outer link **36**, **42**, **48** is approximately 0.5 grams. The mass of the end effector is less than one gram. The moment of inertia of the inner links **34**, **40**, **46** about the axis passing through the center of mass and parallel to the z -axis is $I_1=0.083$ gr-cm². The moment of inertia of the outer links **36**, **42**, **48** about the axis passing through the center of mass and parallel to the z -axis is $I_1=0.016$ gr-cm². The total mass of the planar actuating structure **20** is approximately 150 grams.

Peak force applied by end effector in upward direction is 13.50N.

Maximum continuous force applied by end effector in upward direction is 4.5N.

Peak force applied by end effector in xy plane is 1.5N.

Maximum continuous force applied by end effector in xy plane is approximately 0.55N and substantially uniform throughout the workspace.

The practical range of maximum force applied in xy plane is 0.5–1.5N using a simplex algorithm.

In one embodiment the simplex algorithm is executed at 10 kHz as part of a controller written in assembly and C language on a 486DX 66 MHz general purpose microcomputer.

These values are for an end effector workspace of approximately 1.5 cm³.

Operation—Manipulation and Force Display

The manipulator **10** implemented as a force display is driven in one embodiment by a controller program executed on a general purpose microcomputer. The controller program defines a virtual reality environment or reflects a tele-environment. An operator using his finger, pen-like tool or other device applies forces to the control point **12** moving the control point **12** within the end effector workspace **16**. For forces applied in the xy plane, the planar actuating structure responds to allow movement of the end effector **14**. For forces applied in the z direction, the rotational actuating structures respond to allow common movement of the end effector **14** and planar structure **20** along the z -axis.

By using precision direct-drive actuators and serial-link components, substantially frictionless movement of the con-

trol point is achieved. During testing friction was less than 1 gr-f, backlash nonexistent, and inertia very low. As a result, a control algorithm is able to effectively define a virtual reality or tele-operational environment with a substantially natural feel. The feel is able to be as good as the controller program allows, rather than be limiting by the mechanics of the manipulator.

Concluding Remarks

Although a preferred embodiment of the invention has been illustrated and described, various alternatives, modifications and equivalents may be used. Therefore, the foregoing description should not be taken as limiting the scope of the inventions which are defined by the appended claims.

What is claimed is:

1. A direct drive actuator system responsive to operator manipulation of a control point, comprising:

an end effector defining a control point accessible to manipulation by an operator within an end effector workspace;

first, second and third kinematic chains coupled in parallel to the end effector in common alignment to the control point to define a redundant actuator structure for allowing motion of the control point within a first plane of the workspace to not more than two degrees of freedom;

the first kinematic chain comprising: a first actuator, a first inner link and a first outer link, the first actuator fixed relative to the first plane and coupled to the first inner link, the first inner link coupled to the first outer link to define a first joint, the first outer link coupled to the end effector in alignment with the control point;

the second kinematic chain comprising: a second actuator, a second inner link and a second outer link, the second actuator fixed relative to the first plane and coupled to the second inner link, the second inner link coupled to the second outer link to define a second joint, the second outer link coupled to the end effector in alignment with the control point; and

the third kinematic chain comprising: a third actuator, a third inner link and a third outer link, the third actuator fixed relative to the first plane and coupled to the third inner link, the third inner link coupled to the third outer link to define a third joint, the third outer link coupled to the end effector in alignment with the control point.

2. The actuator system of claim 1 in which positions of the first, second and third actuators in response to operator manipulation at the control point are determined by choosing a torque vector for the respective first, second and third kinematic chains that substantially maximizes the force that can be applied at the control point.

3. The actuator system of claim 1 in which the first kinematic chain further comprises a first optical encoder for sensing position of the first actuator, the second kinematic chain further comprises a second optical encoder for sensing position of the second actuator, and the third kinematic chain further comprises a third optical encoder for sensing position of the third actuator.

4. The actuator system of claim 1 in which the end effector defines a free control point interface allowing an operator to apply a pen-like tool to the control point without the system holding the tool to the control point.

5. The actuator system of claim 1 in which the first, second and third kinematic chains define a common structure, and further comprising a fourth actuator for moving the common structure substantially orthogonal to the first plane within the end effector workspace, wherein the

orthogonal movement movement is substantially decoupled from movement within the first plane within the end effector workspace.

6. The actuator system of claim 1 in which the first, second and third kinematic chains each have a respective anchor point and are coupled in parallel at a common joint; and wherein the control point is aligned with the common joint along a line perpendicular to the first plane; and wherein joint angle for the first joint, second joint and third joint are controlled respectively to define the redundant actuator structure which enables motion of the control point within the first plane of motion to not more than two degrees of freedom.

7. The actuator system of claim 1 in which the first, second and third kinematic chains each have a respective anchor point and are coupled in parallel at a common joint; and wherein the control point is aligned with the common joint along a line perpendicular to the first plane; and wherein output torque for each one of the first actuator, second actuator and third actuator are controlled to define the redundant actuator structure which enables motion of the control point within the first plane of motion to not more than two degrees of freedom.

8. A kinematic system responsive to operator manipulation of a control point, comprising:

first, second and third kinematic chains each having a respective anchor point and being coupled in parallel at a common joint;

an end effector in alignment with the common joint along a line perpendicular to a first plane of motion, the end effector defining a control point accessible to manipulation by an operator to move the control point within an end effector workspace;

wherein position of the common joint with respect to each one of the respective anchor points is controlled respectively to define a redundant control structure which allows motion of the control point within the first plane of motion to not more than two degrees of freedom.

9. The system of claim 8, further comprising a tool for being held to the control point only by a force applied by an operator via the tool, the tool being free to make contact and discontinue contact with the control point under operator control.

10. The system of claim 8 in which the position of the common joint with respect to each anchor point is controlled for each of the first, second and third kinematic chain by applying a respective torque vector to the respective first, second and third kinematic chains that substantially maximizes the force that can be applied at the control point.

11. The system of claim 8 in which the position of the common joint with respect to each anchor point is controlled respectively for each of the first, second and third kinematic chain by defining a joint angle for the respective first, second and third kinematic chains that substantially maximizes the force that can be applied at the control point.

12. A direct drive actuator system responsive to operator manipulation of a control point, comprising:

a tool being held by an operator;

an end effector defining a control point accessible to the tool for manipulation via the tool within an end effector workspace, wherein the tool is free to make contact and discontinue contact with the contact point;

first, second and third kinematic chains coupled in parallel to the end effector in common alignment with the control point to define a redundant actuator structure for allowing motion of the control point within a first plane of the workspace to not more than two degrees of freedom;

the first kinematic chain comprising: a first actuator, a first inner link and a first outer link, the first actuator fixed relative to the first plane and coupled to the first inner link, the first inner link coupled to the first outer link to define a first joint, the first outer link coupled to the end effector in alignment with the control point;

the second kinematic chain comprising: a second actuator, a second inner link and a second outer link, the second actuator fixed relative to the first plane and coupled to the second inner link, the second inner link coupled to the second outer link to define a second joint, the second outer link coupled to the end effector in alignment with the control point; and

the third kinematic chain comprising: a third actuator, a third inner link and a third outer link, the third actuator fixed relative to the first plane and coupled to the third inner link, the third inner link coupled to the third outer link to define a third joint, the third outer link coupled to the end effector in alignment with the control point.

13. The system of claim 12 in which output torque for each one of the first, second and third actuators is chosen in response to operator manipulation at the control point to define a torque vector for the respective first, second and third kinematic chains that substantially maximizes the force that can be applied at the control point.

14. The system of claim 12 in which joint angle for each one of the first joint, second joint and third joint are controlled respectively to define the redundant actuator structure which enables motion of the control point within the first plane of motion to not more than two degrees of freedom.

15. A force feedback interface device for providing low inertia, low backlash, low friction force feedback, comprising:

a reference surface;

an end effector defining a control point for engagement by a user, wherein said control point is translatable in two degrees of freedom with respect to said reference surface;

a first chain coupled between said reference surface and said end effector, said first chain including a first direct drive flat-coil actuator, a first inner link coupled to said first direct drive flat-coil actuator, and a first outer link coupled between said first inner link and said end effector; and

a second chain coupled between said reference surface and said end effector, said second chain including a second direct drive actuator, a second inner link coupled to said second direct drive actuator, and a second outer link coupled between said second inner link and said end effector;

wherein said first chain and said second chain provide parallel couplings between said reference surface and said control point, said first chain and said second chain providing not more than said two degrees of freedom to said control point.

16. The force feedback interface device as recited in claim 15 wherein said second direct drive actuator is a flat-coil actuator, and wherein said first direct drive flat-coil actuator includes a first movable flat coil coupled to a first fixed

magnet and said second drive flat-coil actuator includes a second movable flat coil coupled to a second fixed magnet.

17. The force feedback interface device as recited in claim 15 wherein said reference surface is a base plate.

18. The force feedback interface device as recited in claim 15 wherein said reference surface is a ground surface.

19. The force feedback interface device as recited in claim 16 wherein said first chain includes a first rotary joint coupling the first inner link and the first outer link and said second chain includes a second rotary joint coupling the second inner link and the second outer link.

20. The force feedback interface device as recited in claim 19 wherein said two degrees of freedom are in a horizontal plane of motion.

21. The force feedback interface device as recited in claim 20 wherein said end-effector includes a pen-like elongated member engaged and manipulated by the user.

22. The force feedback interface device as recited in claim 19 wherein said end-effector includes an open tool interface point that can be engaged by a pen-like elongated member wherein the user can freely apply and remove the pen-like elongated member from the end-effector.

23. The force feedback interface device as recited in claim 19 wherein said end-effector includes an open tool interface point that can be engaged by the user's finger.

24. The force feedback interface device as recited in claim 20 further comprising:

a first sensor for detecting the position of the control point within said horizontal plane of motion; and

a second sensor for detecting the position of the control point within said horizontal plane of motion.

25. The force feedback interface device as recited in claim 24 wherein said first and second sensors are optical encoders.

26. The force feedback interface device as recited in claim 19 further including a third chain coupled between said reference surface and said end effector, said third chain including a third direct drive actuator, a third inner link, and a third outer link, one end of said third inner link being coupled to said third actuator through a rotary joint, another end of said third inner link being coupled to one end of said third outer link, another end of said third outer link being coupled to the end effector, wherein said first, second, and third chains provide parallel couplings between said reference surface and said control point.

27. The force feedback interface device as recited in claim 20 further including a rotational actuation assembly coupled to said reference surface for providing an additional degree of motion to the control point by allowing the horizontal plane of motion to be rotated about an axis of rotation.

28. The force feedback interface device as recited in claim 20 further including a vertical actuation assembly coupled to said reference surface for providing an additional degree of freedom to the control point by allowing the horizontal plane of motion to be translated along a z-axis of motion.

29. The force feedback interface device as recited in claim 28 further including a fourth actuator for applying a force along said z-axis of motion.

UNITED STATES PATENT AND TRADEMARK OFFICE
CERTIFICATE OF CORRECTION

PATENT NO. : RE 37,528 E
DATED : January 22, 2002
INVENTOR(S) : Hannaford et al.

Page 1 of 1

It is certified that error appears in the above-identified patent and that said Letters Patent is hereby corrected as shown below:

Title page,

Item [73], change the Assignee from "**Immersion Corporation, San Jose, CA**" to
-- **University of Washington, Seattle, Wash.** --.

Signed and Sealed this

Eighteenth Day of June, 2002

Attest:

A handwritten signature in black ink, appearing to read "James E. Rogan", written over a horizontal line.

Attesting Officer

JAMES E. ROGAN
Director of the United States Patent and Trademark Office