



US00RE37174E

(19) **United States**
(12) **Reissued Patent**
Grawey et al.

(10) **Patent Number: US RE37,174 E**
(45) **Date of Reissued Patent: May 15, 2001**

(54) **FRICTIONALLY DRIVEN BELTED WORK VEHICLE**

FOREIGN PATENT DOCUMENTS

(75) Inventors: **Charles E. Grawey; Robert J. Grob; Cullen P. Hart**, all of Peoria, IL (US)

77535 9/1915 (AT) .
678785 * 6/1939 (DE) .
855960 11/1952 (DE) .
1 201 201 4/1966 (DE) .
223515 10/1924 (FR) .

(73) Assignee: **Caterpillar Inc.**, Peoria, IL (US)

(List continued on next page.)

(21) Appl. No.: **08/674,423**

OTHER PUBLICATIONS

(22) Filed: **Oct. 7, 1996**

Related U.S. Patent Documents

Reissue of:

(64) Patent No.: **5,363,936**
Issued: **Nov. 15, 1994**
Appl. No.: **08/136,837**
Filed: **Oct. 18, 1993**

“Firestone Champion Ground Grips Out Pull All Other Tractor Tires”, *Agricultural Engineering*, May 1948, p. 187.
“No Clanks in These Tracks—and They Love Sand”, *Farm Implement News*, Jun. 21, 1943, p. 28.
“Oliver Model HG Cletrac”, The Oliver Corporation, Cleveland, OH Form No. Spec. H-3, 50M-10-45, U.S.A.
“Rubber Tracks for Agriculture”, C.O. Slemmons, *SAE Journal (Transactions)*, vol. 53, No. 12, Dec. 1945, pp. 713-718.

(List continued on next page.)

U.S. Applications:

(60) Division of application No. 06/938,685, filed on Dec. 3, 1986, now Pat. No. 5,279,378, which is a continuation-in-part of application No. 06/563,338, filed on Dec. 20, 1983, now abandoned.

Primary Examiner—Kevin Hurley

(74) *Attorney, Agent, or Firm*—Claude F. White; Larry G. Cain; Jeffrey A. Greene

(51) **Int. Cl.**⁷ **B62D 55/088; B62D 55/104; B62D 55/24**

(57) **ABSTRACT**

(52) **U.S. Cl.** **180/9.21; 305/111; 305/170**

(58) **Field of Search** 180/9.1, 9.21, 180/9.36, 9.54, 9.5, 10; 305/100, 114, 115, 132, 133, 134, 135, 136, 157, 165, 167, 170, 178, 143, 145, 180, 193, 184, 138

An elastomeric belt laying vehicle is disclosed for transmitting greater tractive effort to the earth as compared to comparably powered wheel vehicles and being operable at high speed on improved road surfaces without inflicting damage thereto. A pair of the wheels are arranged on each lateral side of the vehicle's chassis for support thereof. An inextensible, endless belt is highly tensioned throughout its length, is entrained about each pair of wheels, and is frictionally, drivingly coupled to at least one wheel of each pair. The structure of the belt, structure of the wheels and cooperating components thereof ensure engagement therebetween, provides long service with minimum maintenance thereof, and supplies the necessary frictional couple to effectively transmit driving torque from the wheels to the belt.

(56) **References Cited**

U.S. PATENT DOCUMENTS

107,702 9/1870 Minniss .
990,648 4/1911 Hamilton .
1,170,755 2/1916 Huddle .
1,196,922 9/1916 Black .
1,275,670 8/1918 Fry et al. .

(List continued on next page.)

26 Claims, 9 Drawing Sheets

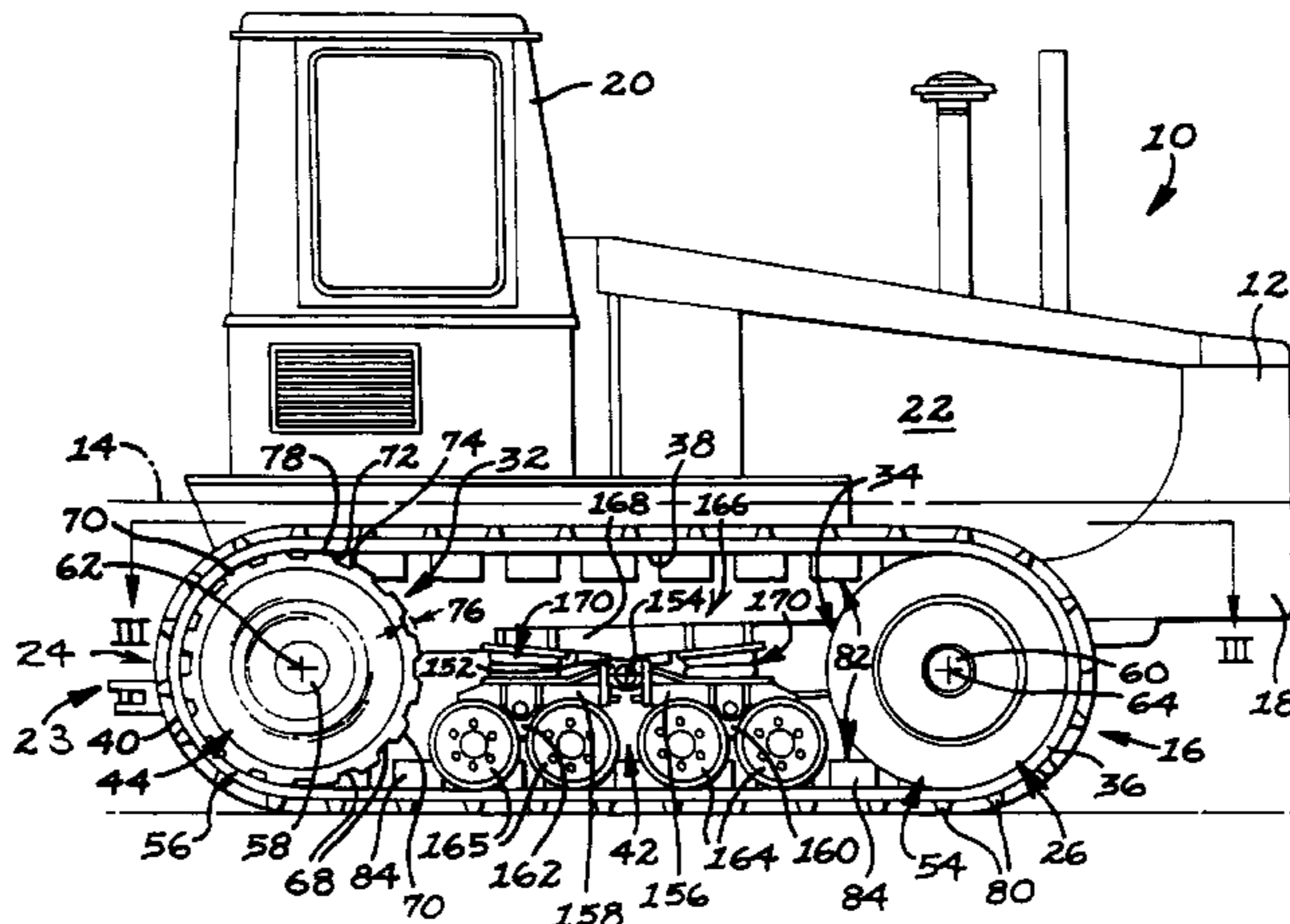

US RE37,174 E

Page 2

U.S. PATENT DOCUMENTS

1,297,104	*	3/1919	Colahan	305/134
1,335,421		3/1920	Black	.
1,355,540		10/1920	Cox	.
1,397,139		11/1921	Muscott	.
1,397,314		11/1921	Cox	.
1,434,239		10/1922	Williams	.
1,522,157		1/1925	Tracy et al.	.
1,539,582	*	5/1925	Landry	305/134
1,800,979		4/1931	Bayard et al.	.
1,821,196		9/1931	Worley	.
1,861,866		6/1932	Knox et al.	.
1,959,972		5/1934	Wanamaker	.
1,986,865		1/1935	Tschappat	305/10
2,043,235		6/1936	Colby	305/10
2,064,890		12/1936	Dorst	305/10
2,107,490		2/1938	Mayne	305/10
2,303,945		12/1942	Mayne et al.	305/9
2,325,690		8/1943	Leguillon	305/10
2,338,817	*	1/1944	Mayne	305/170
2,342,953		2/1944	Mayne	305/10
2,416,679		3/1947	Curtis	305/9
2,449,421		9/1948	Slemmons et al.	305/10
2,452,671		11/1948	Merrill	305/9
2,461,850		2/1949	Slemmons	305/8
2,476,828		7/1949	Skromme	305/10
2,533,271		12/1950	Livermon	305/9
2,541,943		2/1951	Sherman et al.	180/9.1
2,575,845		11/1951	Singer	305/10
2,592,441		4/1952	Louthan	43/43.11
2,592,541		4/1952	Curtis	305/10
2,707,403		5/1955	Thomson et al.	74/230.7
2,829,013		4/1958	Patrick	305/10
2,865,214		12/1958	Runton	74/231
2,887,343		5/1959	West	305/10
2,891,821		6/1959	Mayr	305/3
2,992,863	*	7/1961	Fredricks et al.	305/111 X
2,998,998	*	9/1961	Hylar et al.	305/145
3,082,044		3/1963	Klemm et al.	305/12
3,107,128	*	10/1963	Ruane	305/178
3,112,727		12/1963	Kiefer	115/1
3,113,805	*	12/1963	Nodwell	305/15
3,155,436		11/1964	Bonmartini	305/13
3,216,520	*	11/1965	Blonsky	305/138
3,354,735		11/1967	Holz	74/230.7
3,378,314		4/1968	Knowles	305/13
3,392,594		7/1968	Van Gorp	74/230.6
3,451,728		6/1969	Sherbrooke	305/13
3,484,140		12/1969	Grenier	305/35
3,592,279		7/1971	Donelson, Jr.	180/5
3,600,044		8/1971	Cushman	305/20
3,606,496		9/1971	Haycock	305/29
3,609,804		10/1971	Morrison	180/9
3,683,728		8/1972	Meserve	83/12
3,688,858		9/1972	Jespersen	180/9.62
3,801,164		4/1974	Mazzarins	305/23
3,820,580		6/1974	Meserve et al.	157/230.7
3,886,788		6/1975	Jeter, Jr.	73/117
4,040,464		8/1977	Skidmore	152/361 R
4,081,016		3/1978	Clayton	.
4,089,565		5/1978	Loegering et al.	.
4,093,318		6/1978	Edwards	305/11
4,144,923		3/1979	Curry	157/13

4,198,103	*	4/1980	Ward et al.	305/110 X
4,233,853		11/1980	Holz	74/185
4,281,882		8/1981	van der Lely	305/35 EB
4,284,409		8/1981	Van Teslaar	474/185
4,306,607		12/1981	Curry	157/13
4,351,572		9/1982	Fujiwara et al.	305/27
4,362,340		12/1982	van der Lely	305/31
4,364,426		12/1982	Mills et al.	152/209 R
4,410,219		10/1983	van der Lely	305/35 EB
4,448,273		5/1984	Barbieri	180/9.21
4,449,756	*	5/1984	Weeks	305/115 X
4,519,654	*	5/1985	Satzler et al.	180/9.54 X
4,537,267	*	8/1985	Satzler	305/155 X
4,560,018	*	12/1985	Satzler	180/9.1
4,781,257	*	11/1988	Gee et al.	180/9.5
4,906,054	*	3/1990	Edwards et al.	305/167 X
5,161,866	*	11/1992	Johnson	305/136
5,246,246	*	9/1993	Kendall	305/155 X
5,279,378	*	1/1994	Grawey et al.	305/114 X
5,352,029	*	10/1994	Nagorcka	305/115 X

FOREIGN PATENT DOCUMENTS

594998		3/1925	(FR)	.
622093		7/1926	(FR)	.
650960		3/1928	(FR)	.
728403		12/1931	(FR)	.
1075239		12/1952	(FR)	.
1355528		2/1964	(FR)	.
1 427 191		12/1965	(FR)	.
2 502 573		3/1982	(FR)	B62D/55/30
256796		8/1926	(GB)	.
278779	*	10/1927	(GB)	.
452982		9/1936	(GB)	.
702974		1/1954	(GB)	.
2 104 015		3/1983	(GB)	.
81/01395		5/1981	(WO)	.

OTHER PUBLICATIONS

“Siping Improves Tire Traction and Tread Life”, from National Louis University.

“The ‘Square–Wheel’ Tractor Goes to Town”, Robert Mayne and H.W. Delzell, SAE Journal (Transactions), vol. 50, Mar. 1942, pp. 97–101.

“The New Cletrac Model HG With Full View Features”, The Cleveland Tractor Co., Cleveland, OH, Form No. 907–12–39, U.S.A.

“These Tracks Don’t Clank”, Farm Implement News, Dec. 26, 1940, p. 39.

“Track and Tire Performance in Agricultural Soils”, J.H. Taylor and E.C. Burt, ASAE Paper No. 73–1509, Dec. 1973.

“Tread Design Effect on Winter Traction”, Thomas R. King and Frank E. Matyja, SAE Technical Paper Series 810067, Feb. 1981.

Mechanical Engineers’ Handbook, edited by Lionel S. Marks, Fifth Edition, McGraw–Hill Book Co., Inc. N.Y., 1951, pp. 228–229, 1381–1389.

Photocopy of photograph of “Oliver HGR–47”.

Copy a portion of publication “Implement & Tractor” 1947.

* cited by examiner

FIG 1

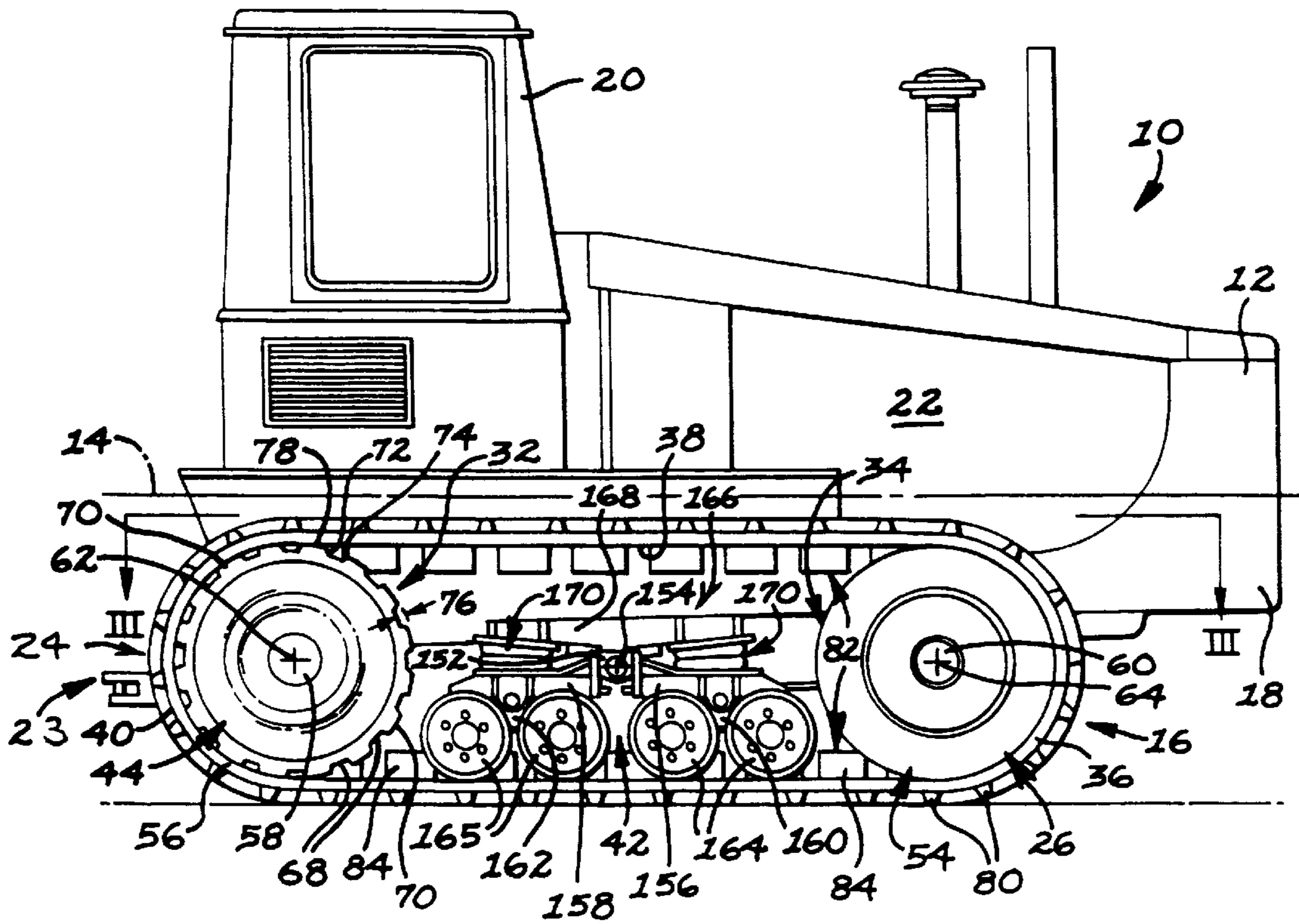

FIG 2

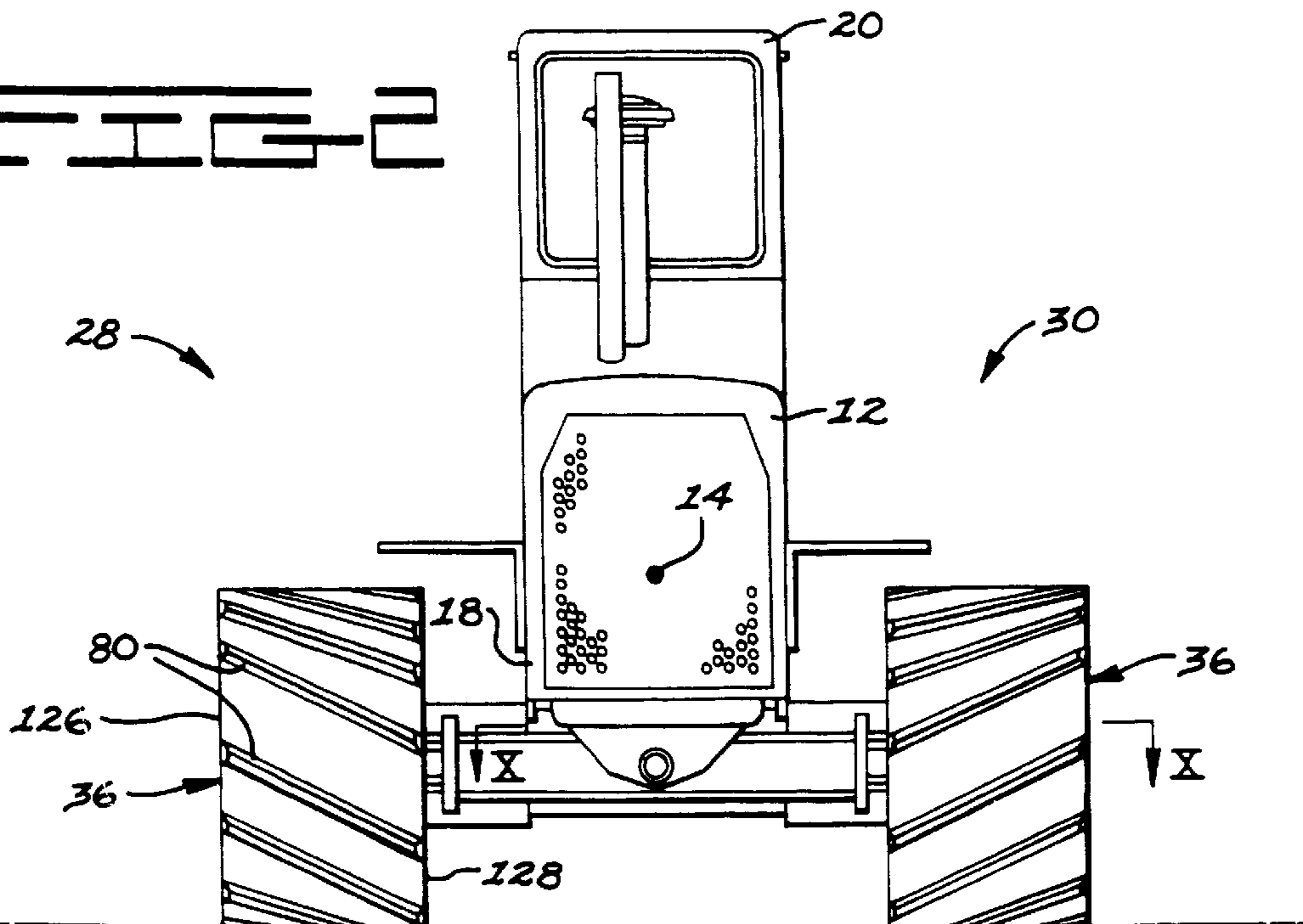

FIG 3

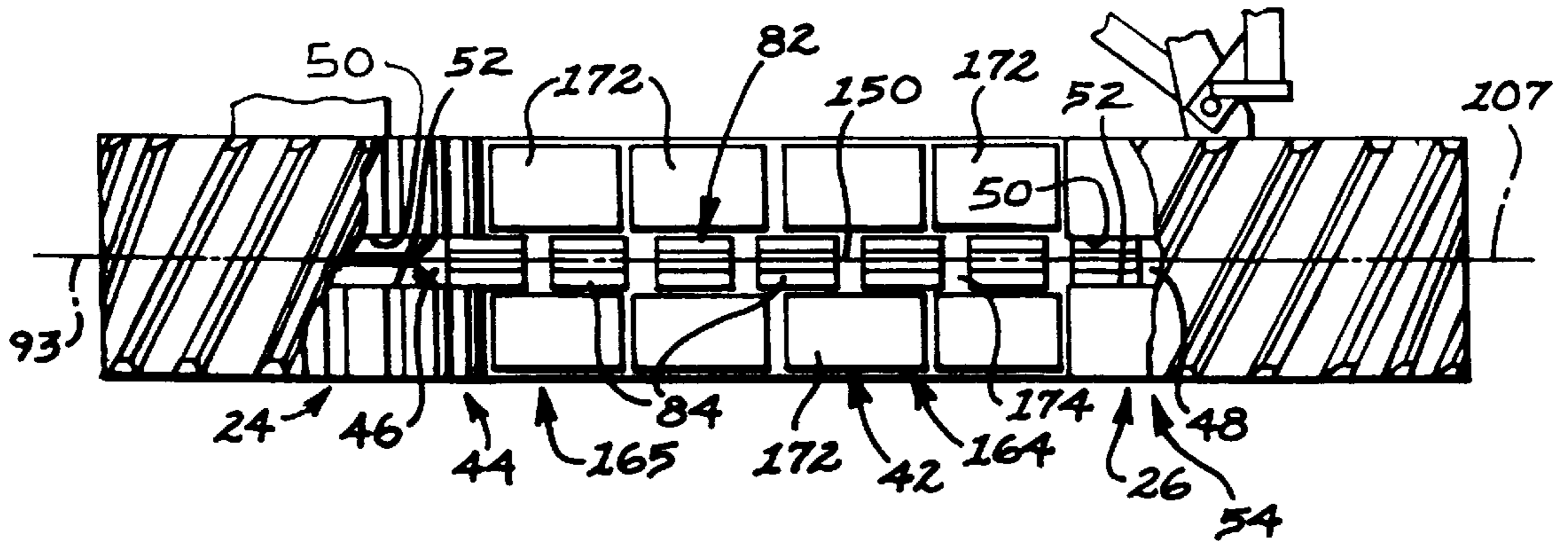

FIG 4

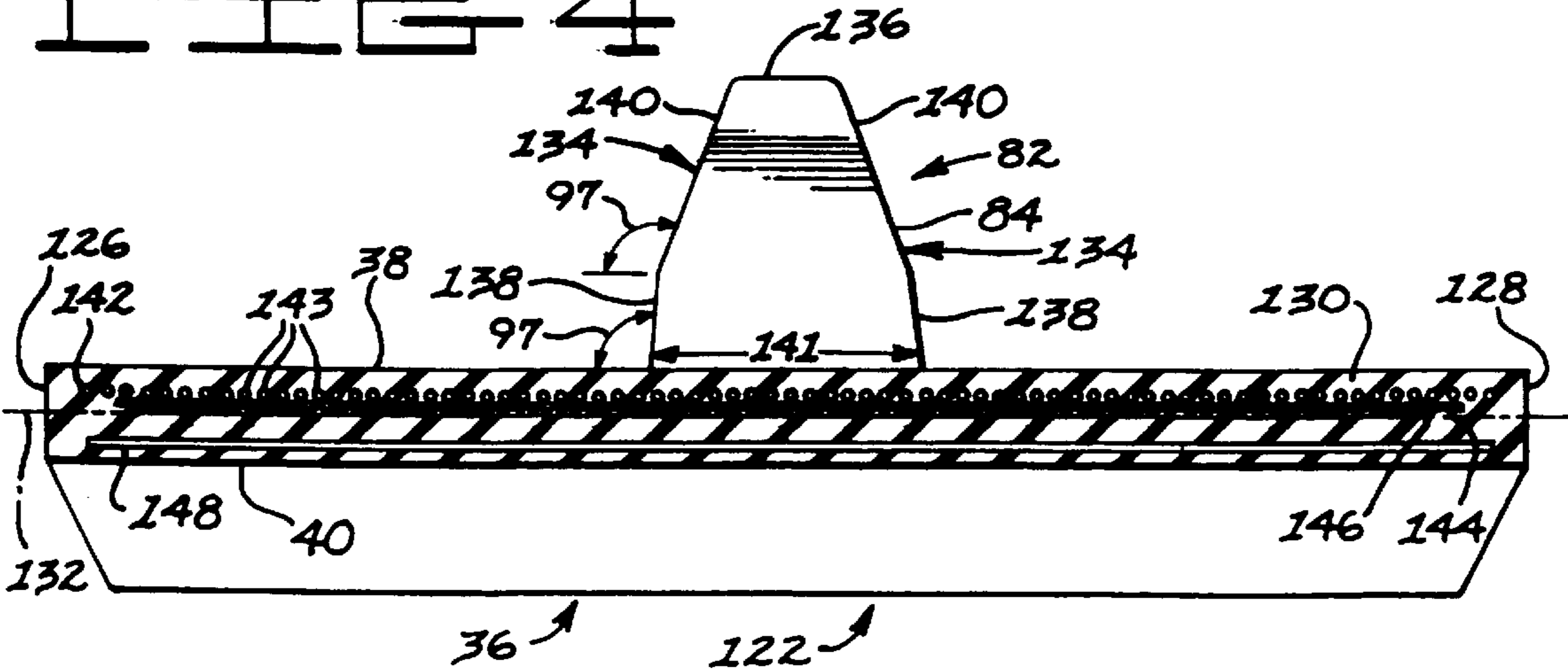
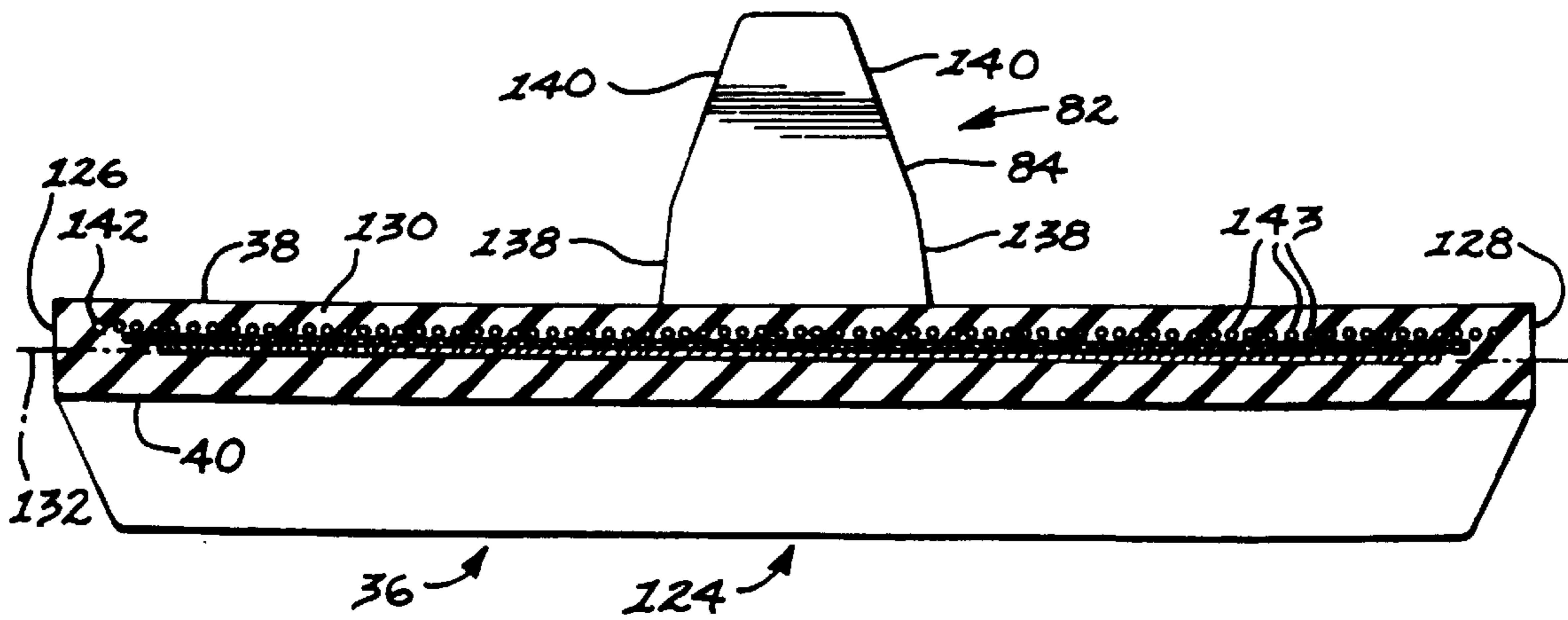
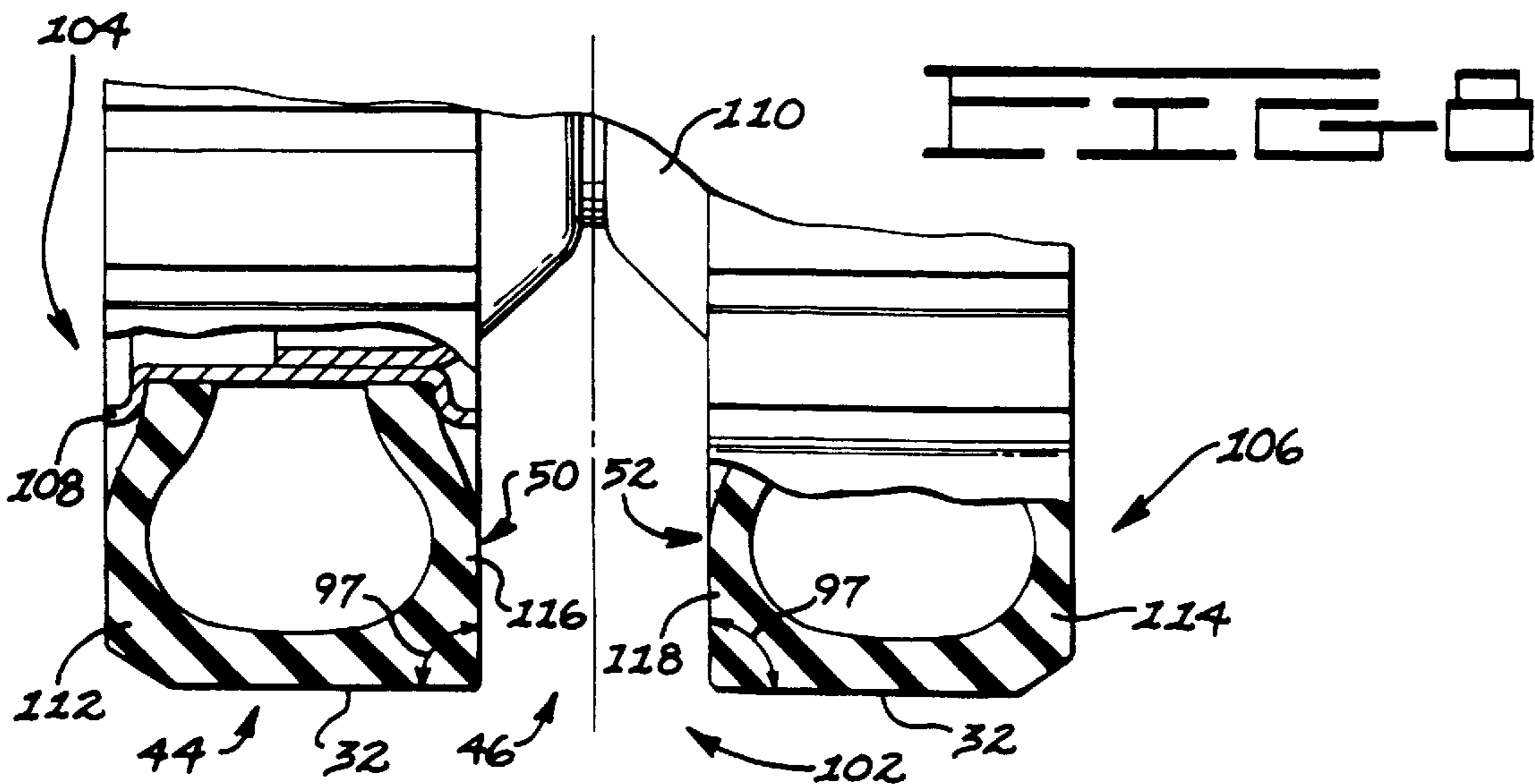
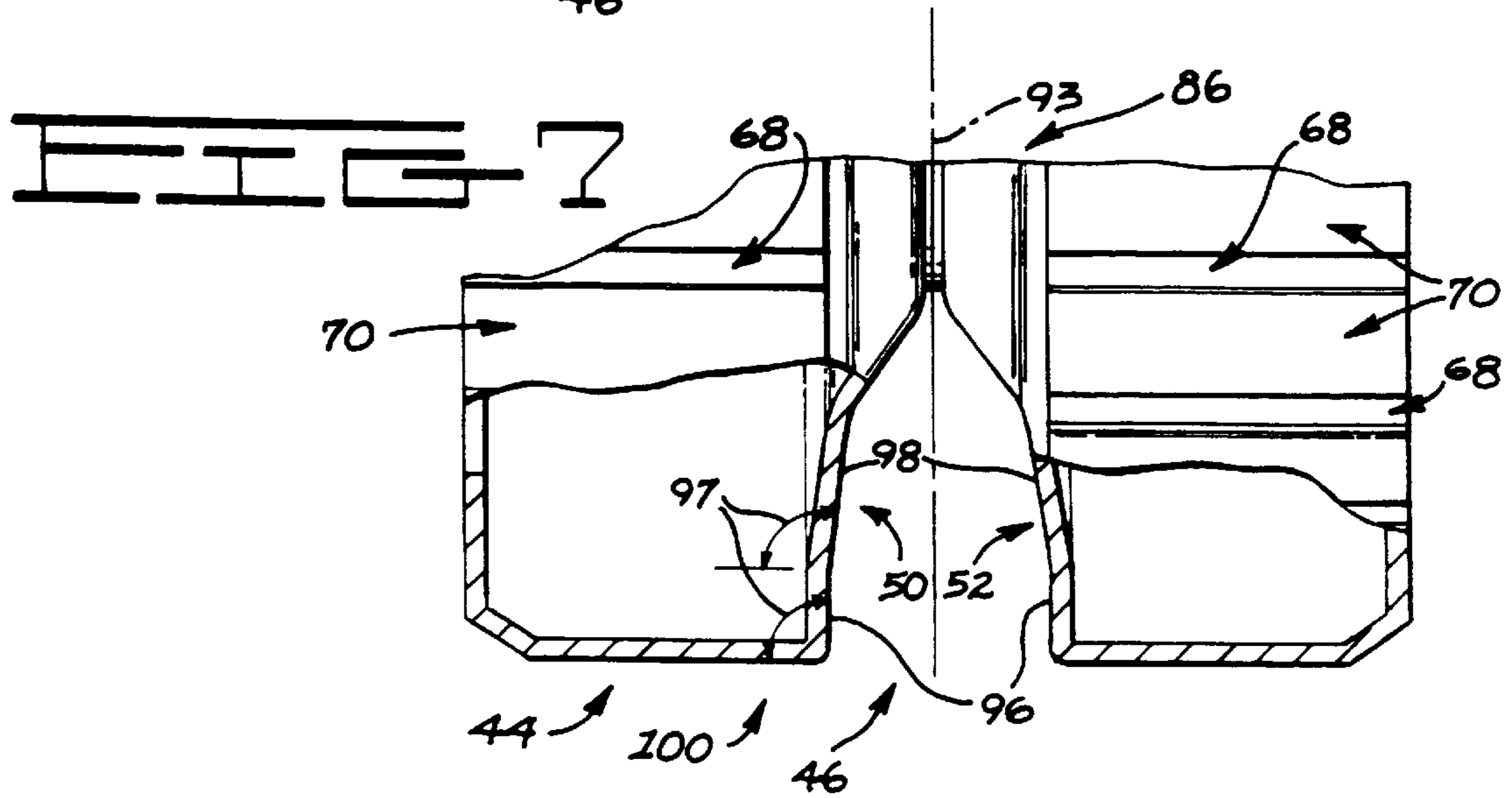
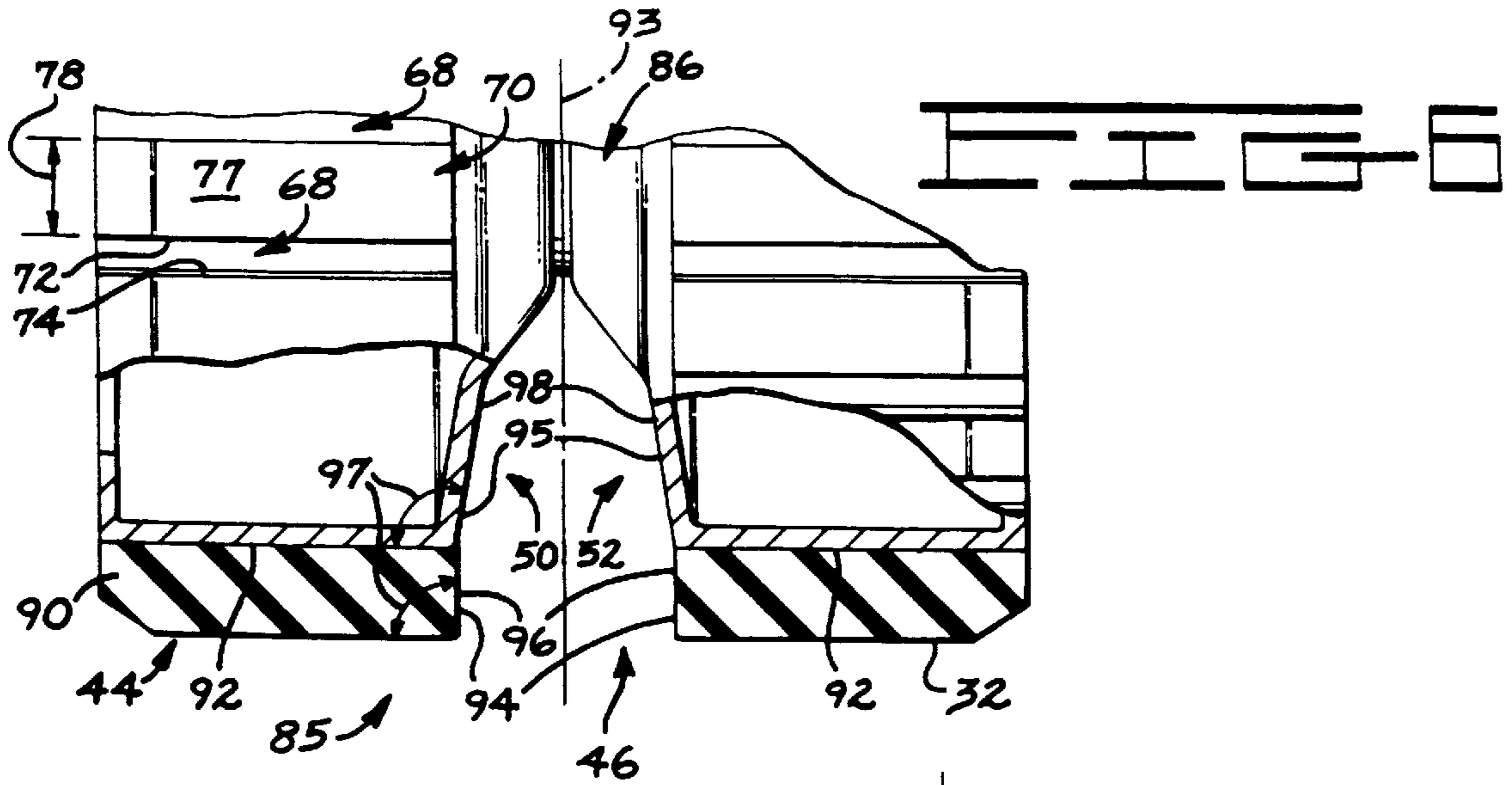

FIG 5





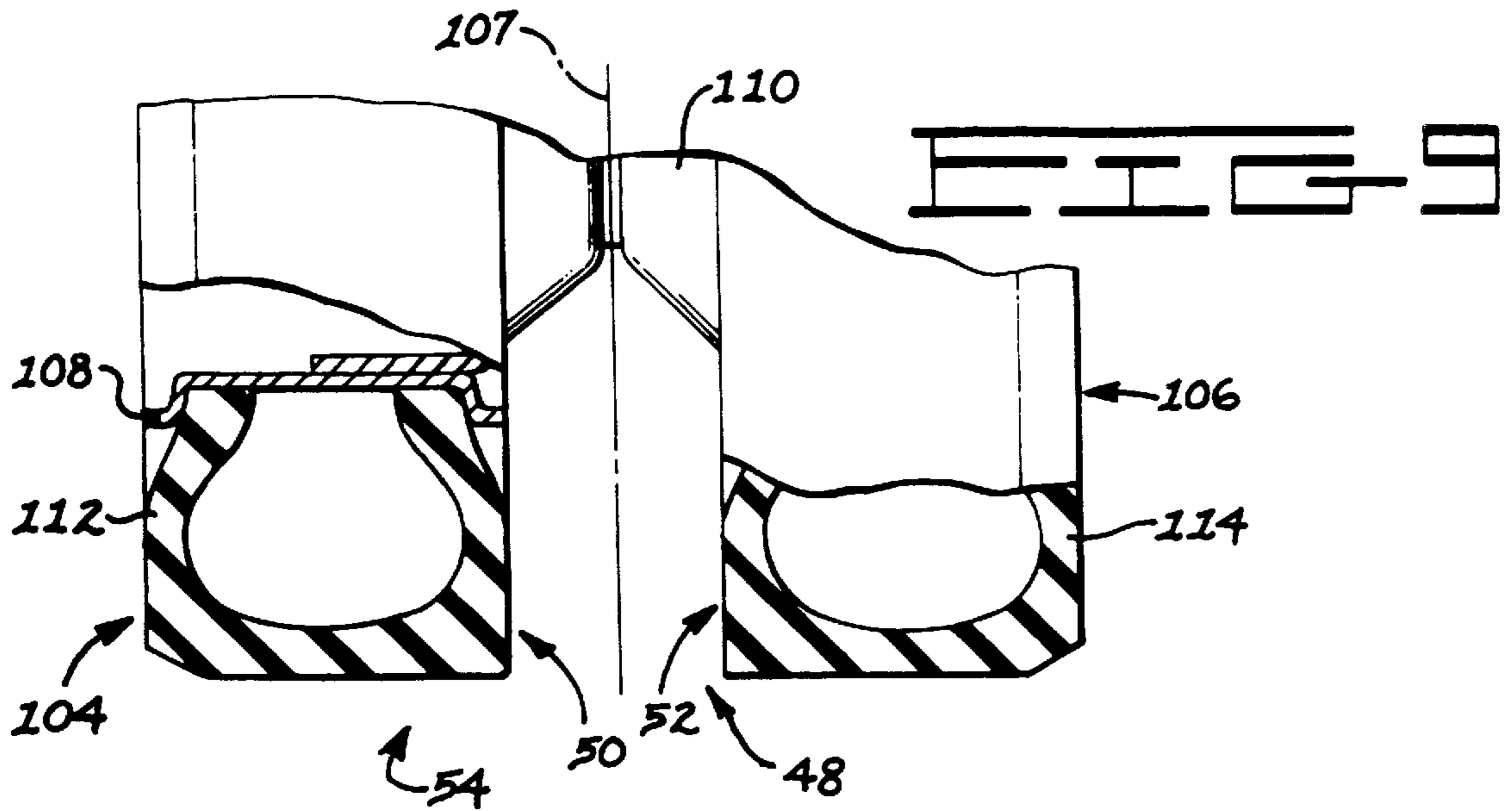

FIG. 11A

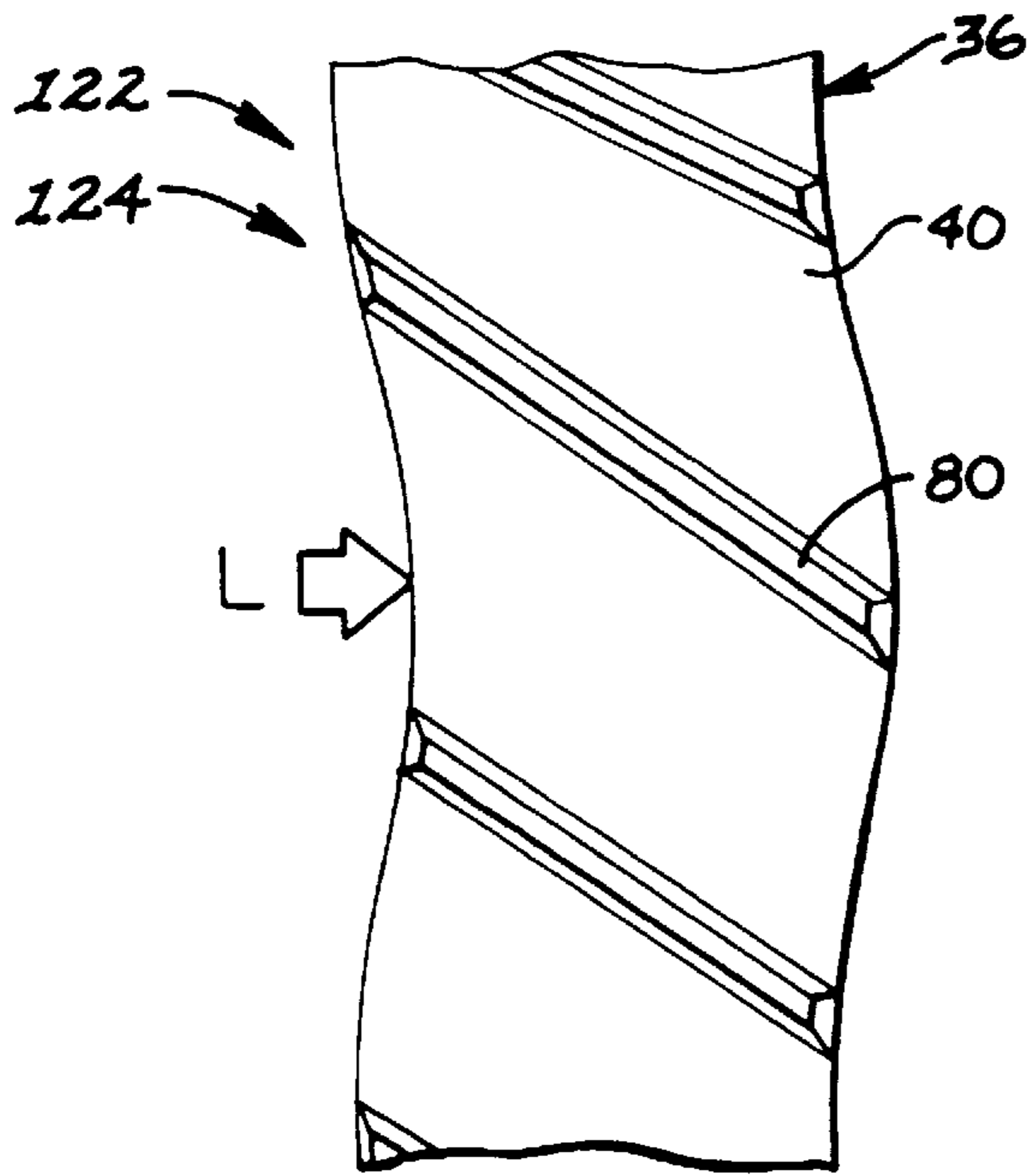

FIG. 11B

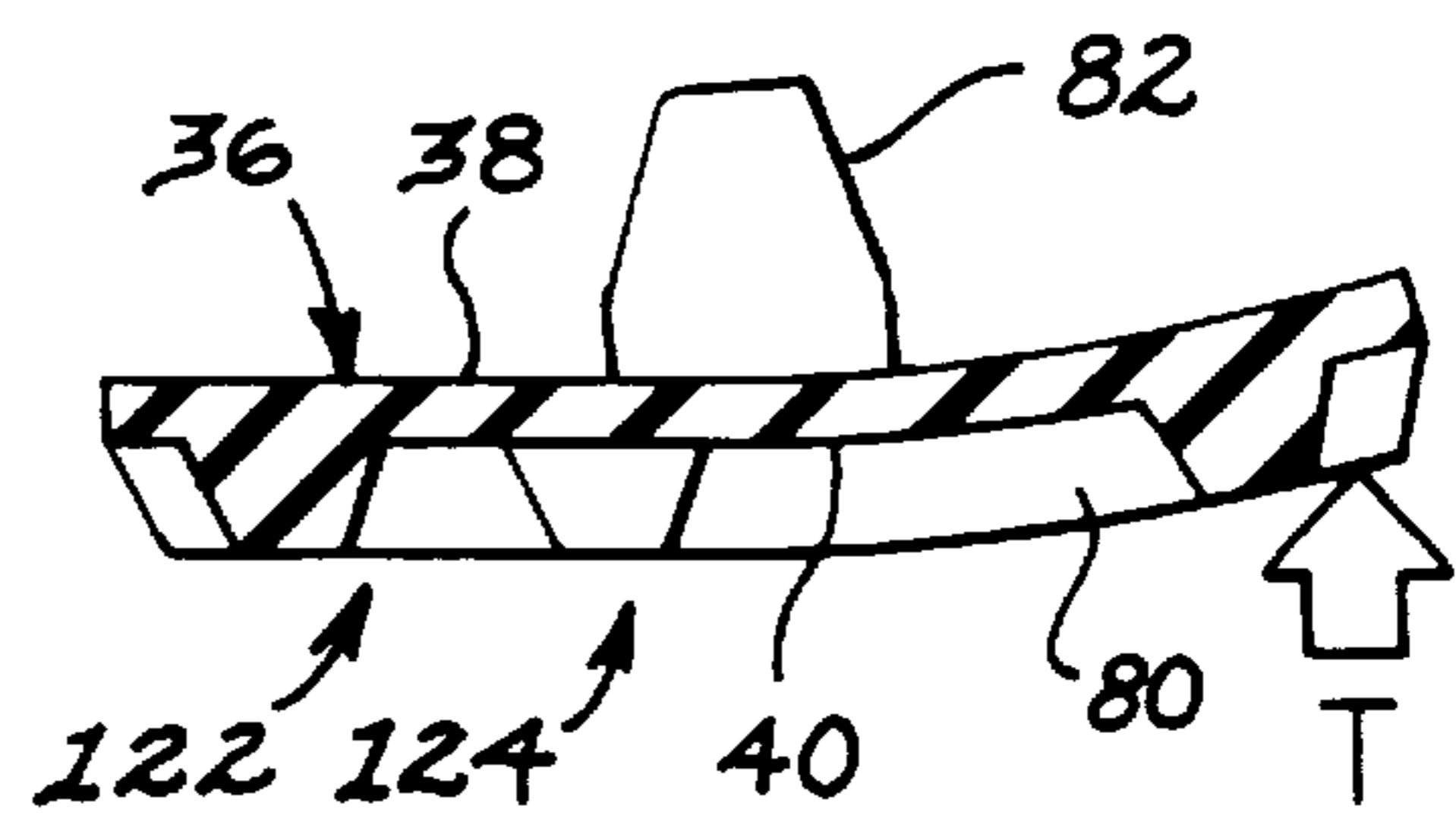

FIG 10

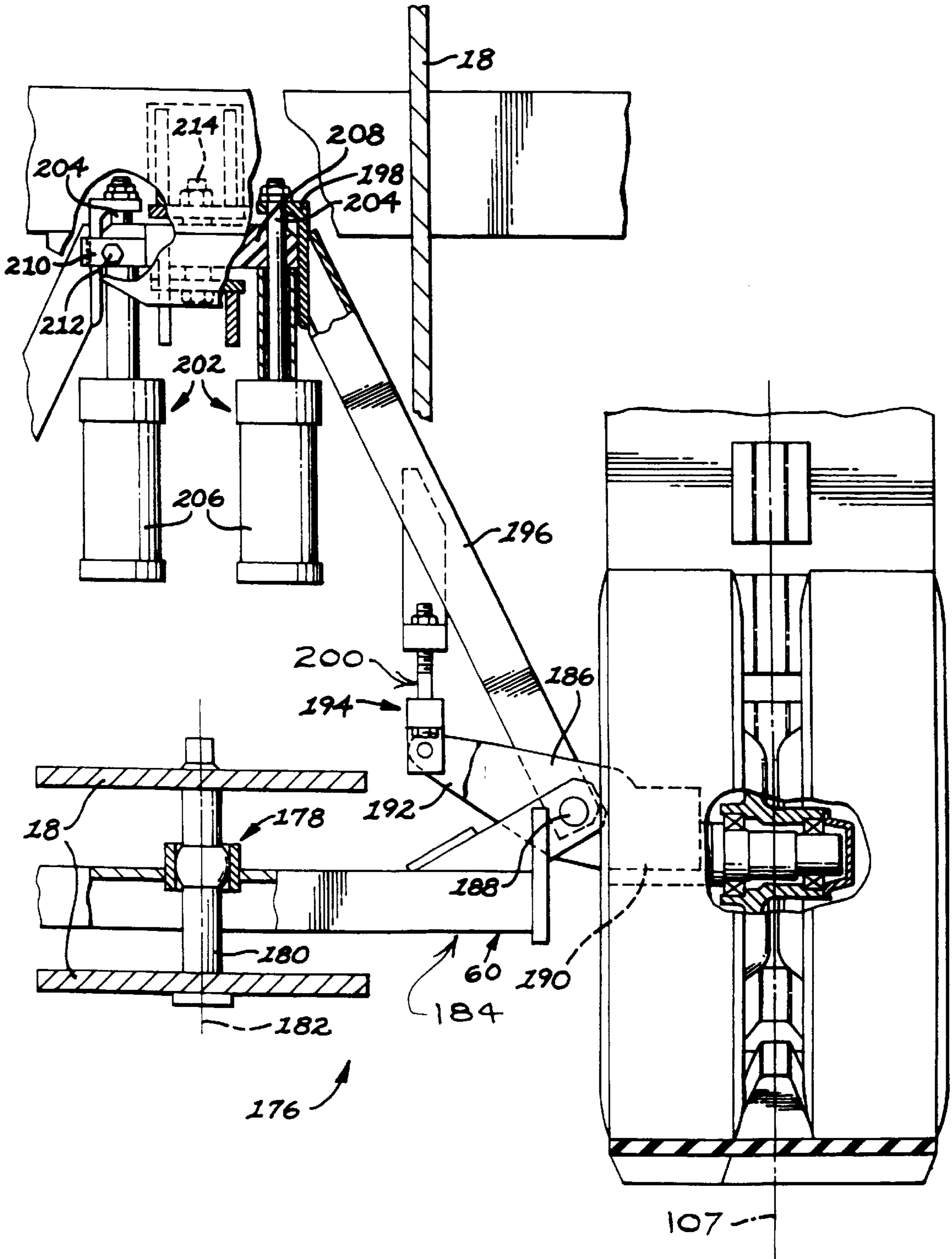

FIG-12A

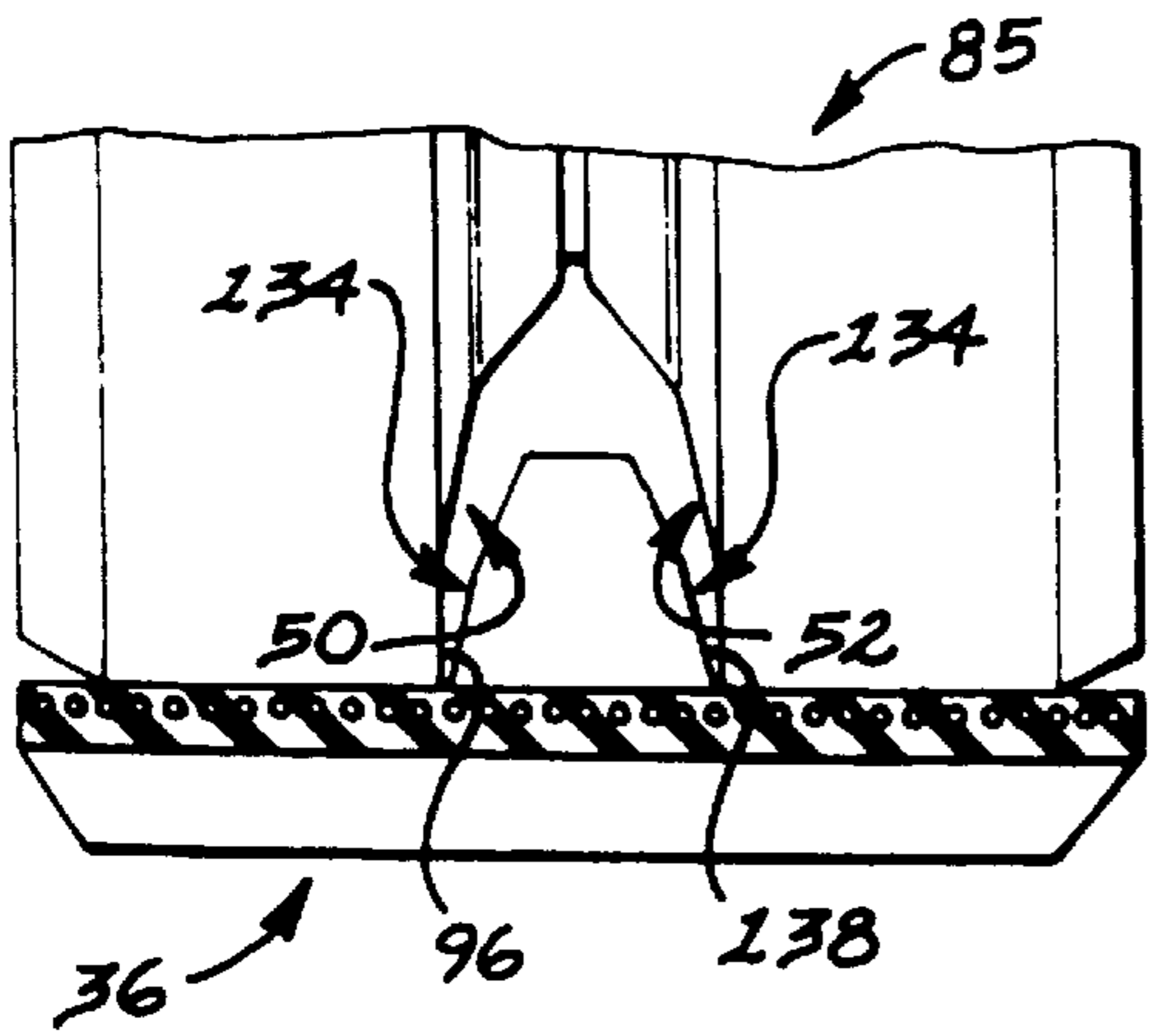

FIG-12B

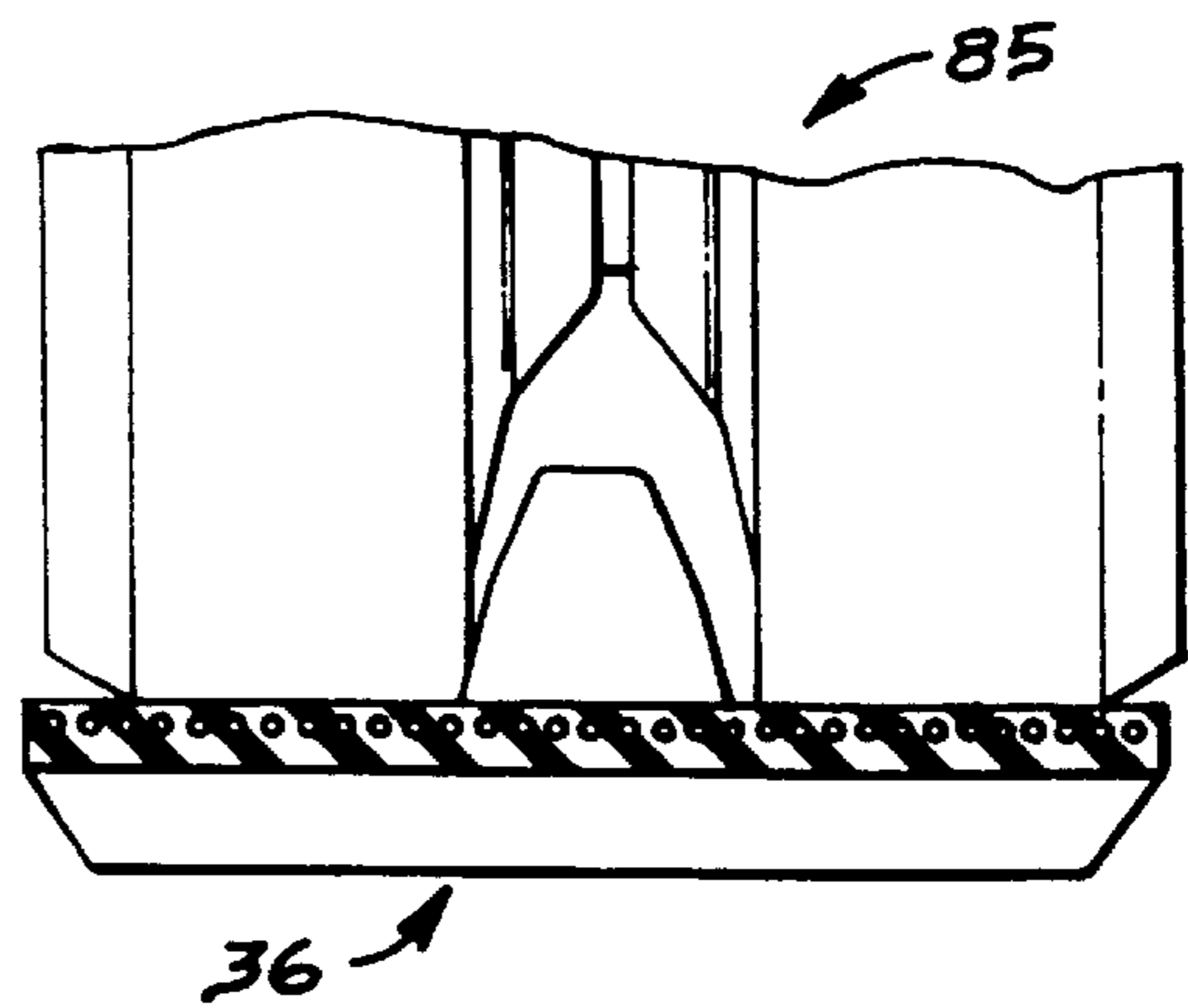

FIG-12C

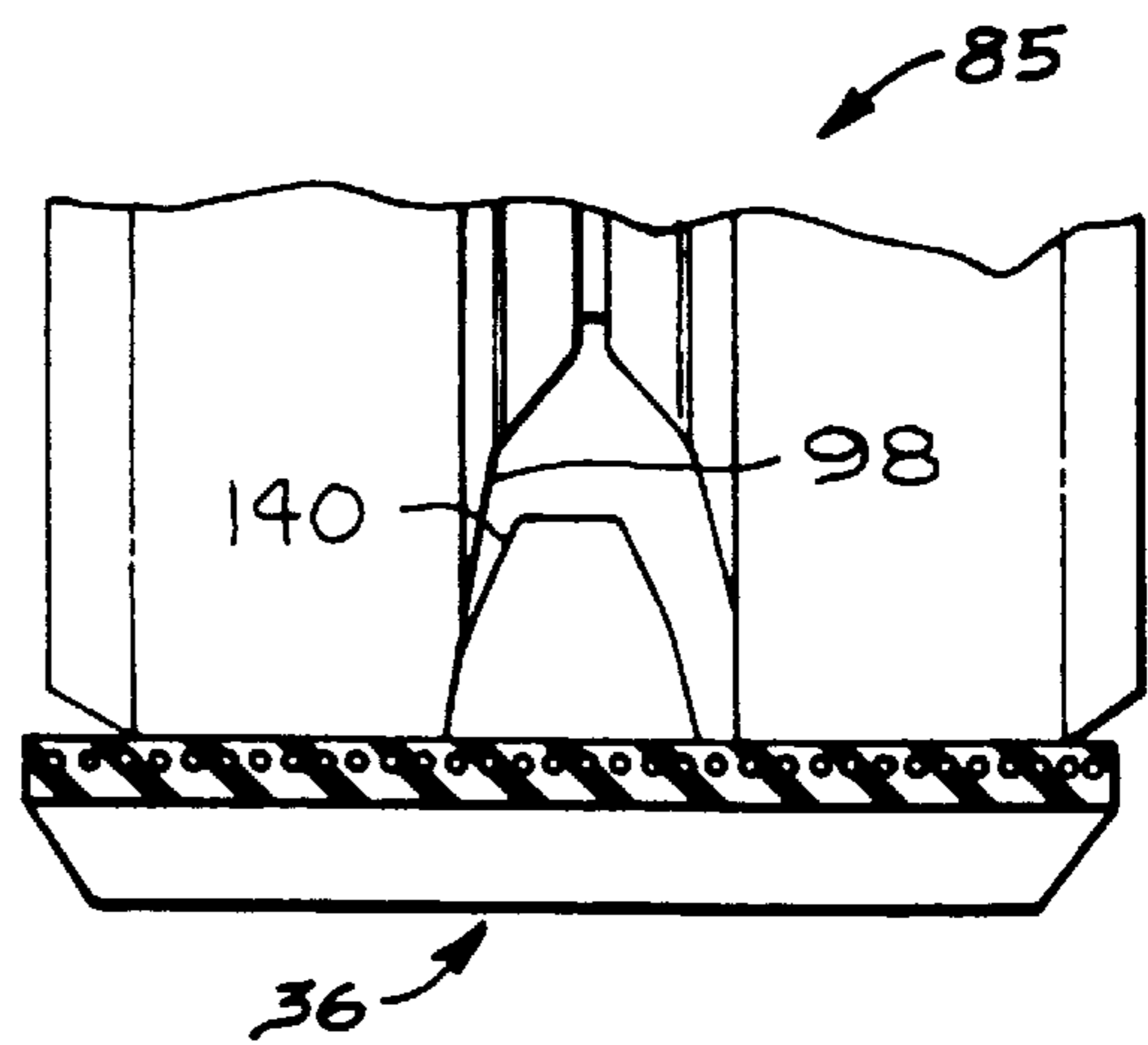
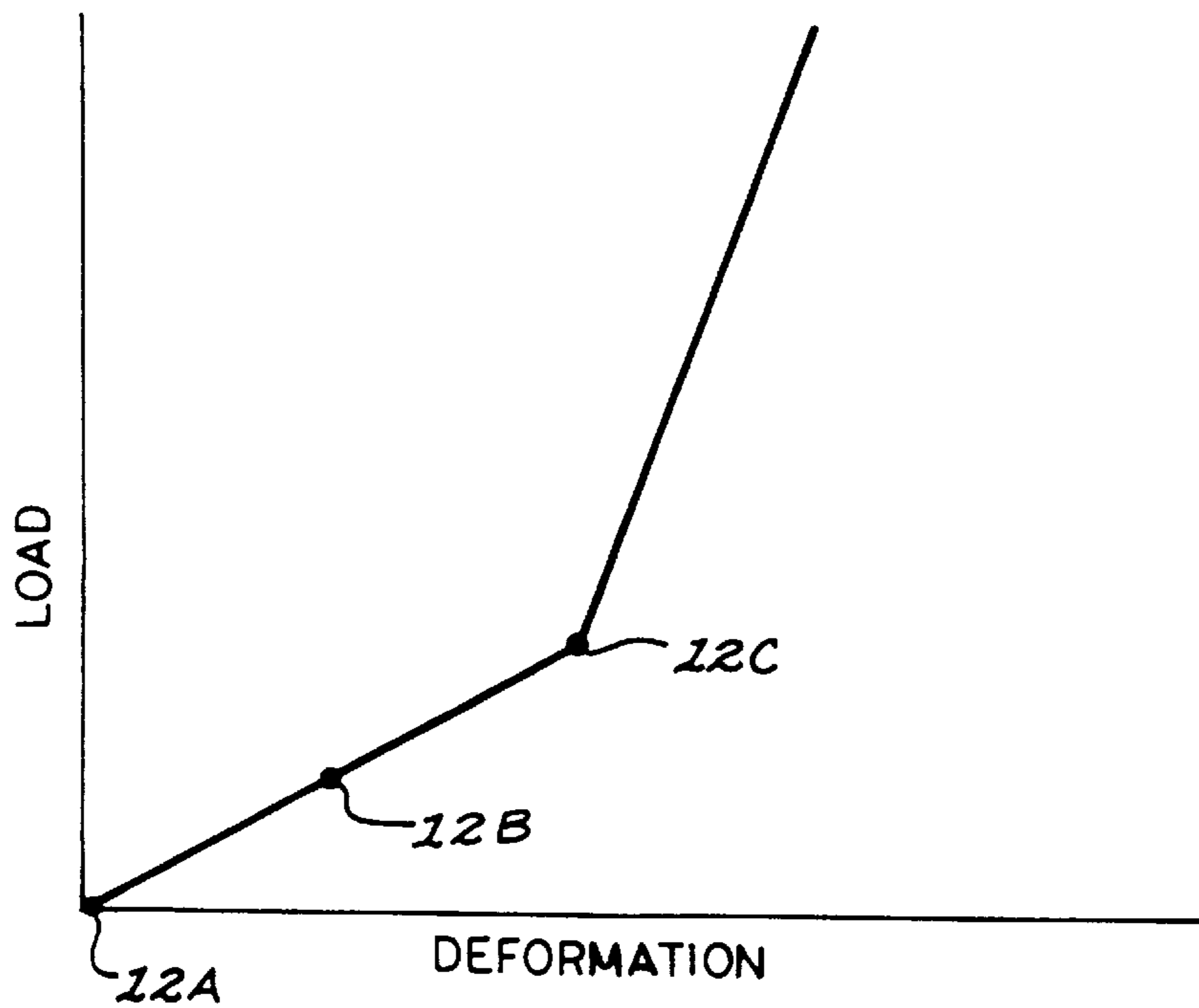
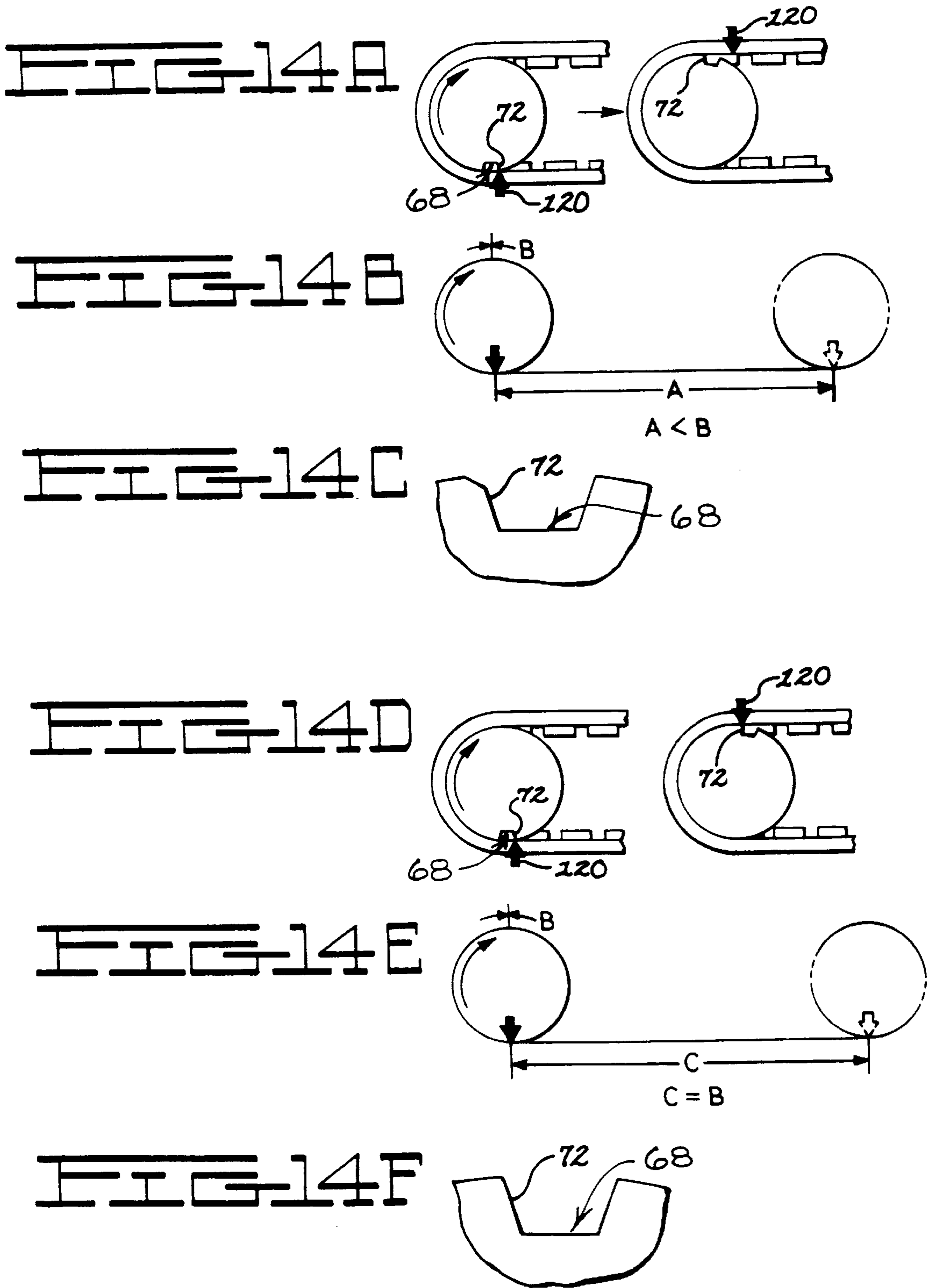

FIG-13





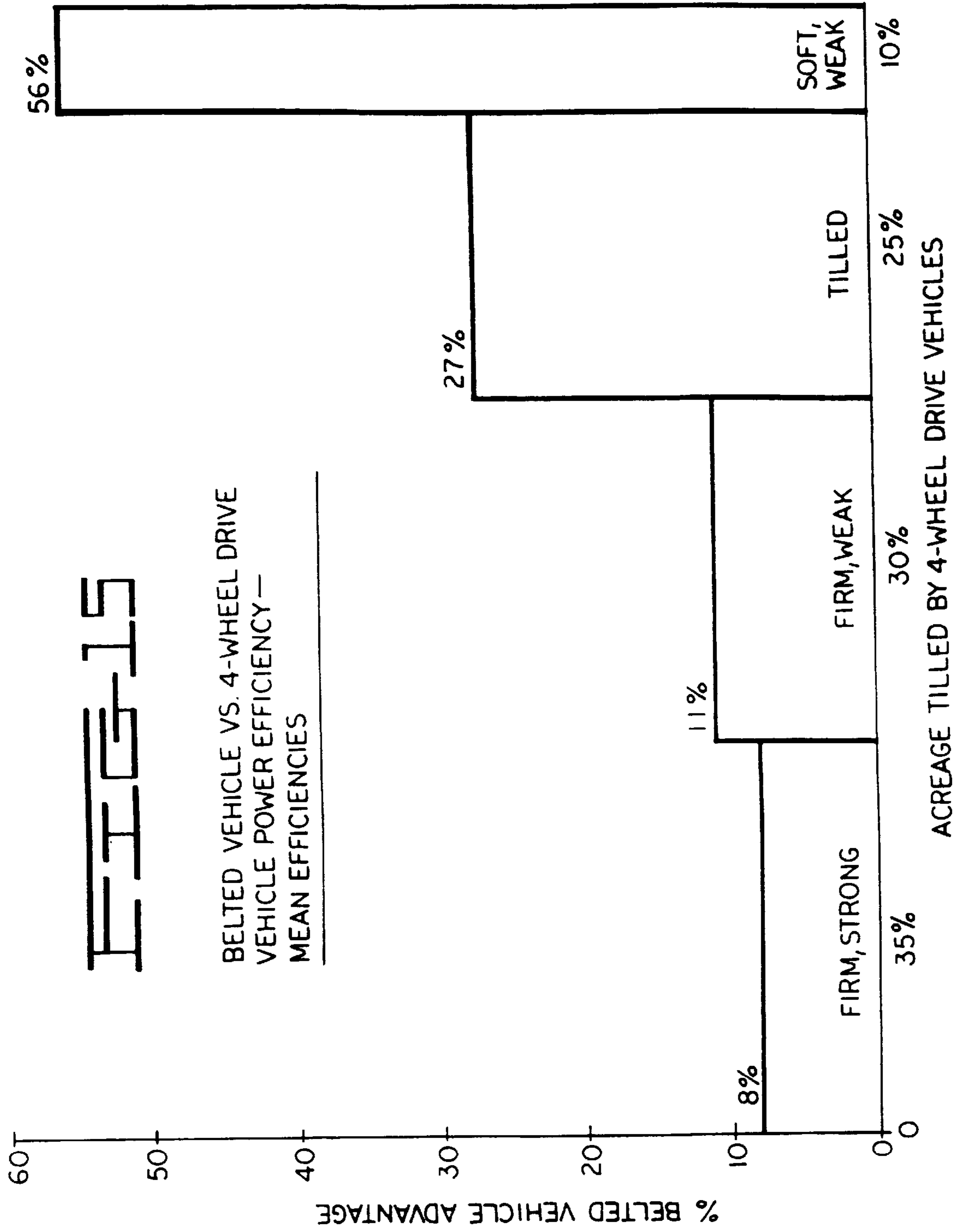
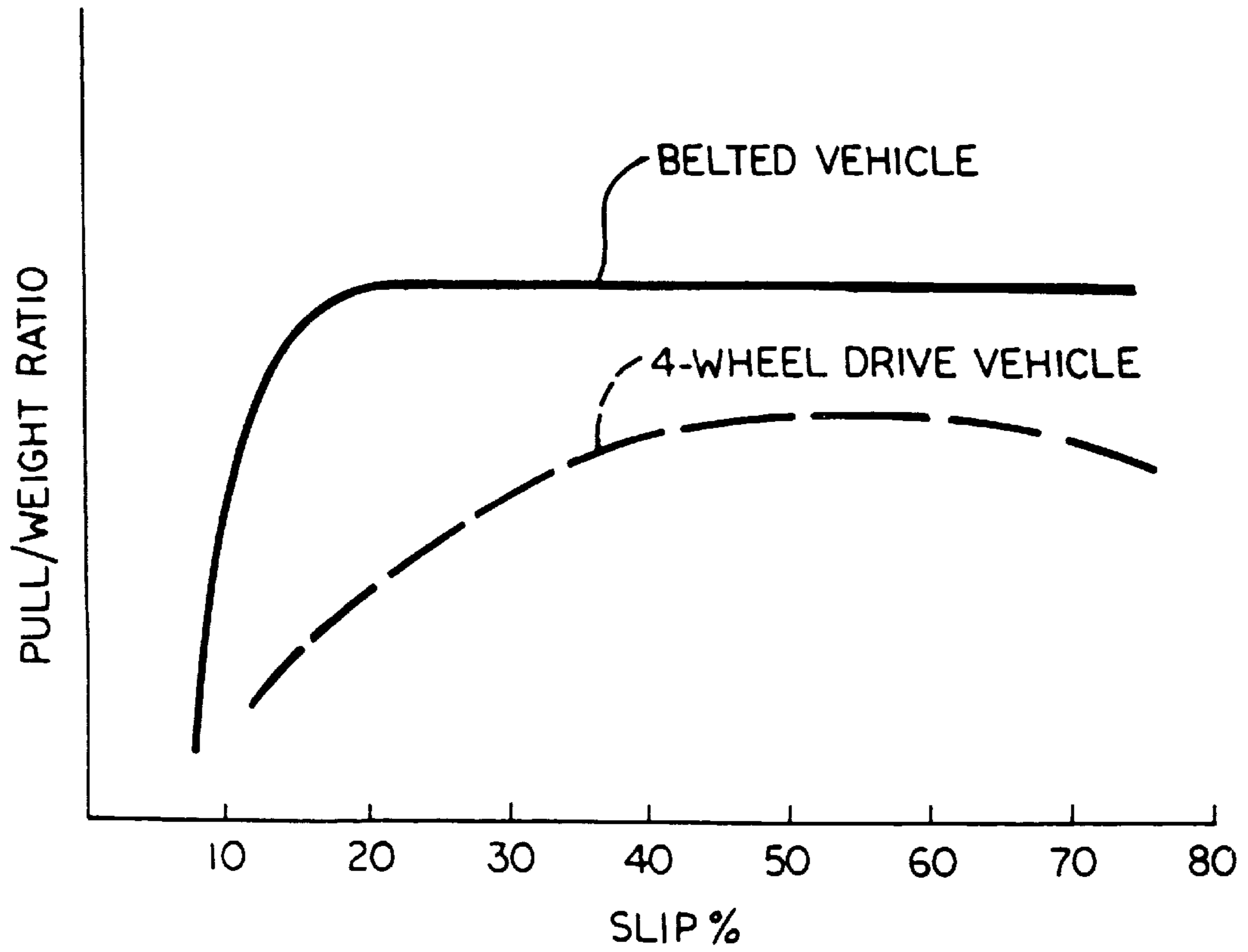

FIG. 16



FRICTIONALLY DRIVEN BELTED WORK VEHICLE

Matter enclosed in heavy brackets [] appears in the original patent but forms no part of this reissue specification; matter printed in italics indicates the additions made by reissue.

CROSS REFERENCE TO RELATED APPLICATION

This is a divisional of application Ser. No. 06/938,685, filed Dec. 3, 1986, U.S. Pat. No. 5,279,378 which is a continuation-in-part of application Ser. No. 563,338, filed Dec. 20, 1983, now abandoned.

TECHNICAL FIELD

This invention relates to crawler-type vehicles, tractors or equipment having tracks over wheels for providing both ground support and tractive effort, and more particularly, to a system for frictionally transmitting motive force through an interface between a wheel and a ground engaging belt.

BACKGROUND ART

It has long been recognized that vehicles having ground engaging/propulsion systems which utilize track have higher traction in soil and cause less ground compaction than vehicles of comparable weight equipped with propulsion systems utilizing solid or pneumatic-tire-equipped wheels. The "footprint" or engagement area of track propulsion systems with the ground is larger than the footprint which is practically achievable by wheel propulsion systems due to the footprint of each wheel being relatively small. In an attempt to compensate for such reduced footprint, large wheel vehicles such as agricultural tractors often have four and sometimes six wheels mounted on each axle. Propulsion systems for agricultural applications today, however, nearly exclusively utilize pneumatic tires rather than track. Present day efforts to increase traction and reduce soil compaction have centered around optimizing wheel propulsion systems even though track systems inherently provide such objectives. As stated in the *Agricultural Engineer*, Winter 1982 Edition, page 109, "Now that the pneumatic tire provides the almost universal means of obtaining traction in agriculture, it is timely to incorporate a system of in-work tire pressure control which will enable tire deflection levels to be kept constant throughout the working cycle. The quest for increased traction with reduced levels of soil compaction makes the adoption of such a system increasingly desirable."

The popularity and nearly universal acceptance of wheel propulsion systems rather than track systems in agricultural use stems primarily from the present day track system's relatively higher noise levels, higher initial cost, lower maximum travel speed, and inability to transport itself on improved road surfaces without inflicting unacceptable damage. While the noise level and roading problems exhibited by conventional track may be minimized by cushioning the ground engaging surface thereof, commercially unacceptable high wear rates generally occur at the moveable joints between the rigid track sections when such conventional track is used in high speed applications.

Those skilled in the art have recognized that the foregoing advantages of wheel and track propulsion systems could be realized by utilizing a propulsion system in which a continuous rubber belt is entrained about a pair of wheels. Problems encountered in actually reducing such belt system

to practice include how to drive such belt with the entrained wheels, how to maintain structural integrity of the belt and wheels, how to retain the belt in lateral alignment with the wheels when the wheels are subjected to large lateral loads, how to provide long life for the belt and wheels, and how to accommodate debris ingestion between the wheels and belt while maintaining the driving relationship therebetween without damaging either.

Limited success has been achieved in providing belt systems for some light duty applications such as snowmobiles. Light duty belt systems utilizing positive drives are illustrated, by example, in U.S. Pat. Nos., 3,510,174 and 3,858,948 which issued May 5, 1970 and Jan. 7, 1975, respectively. An example of a light duty vehicle utilizing friction drive is illustrated in U.S. Pat. No. 4,198,103 which issued Apr. 15, 1980. Attempts to expand the use of belt systems to heavy-duty commercial applications have, in general, met with failure. The following U.S. patents are directed toward resolving the previously described belt system problems by utilizing positive belt drives and applying them to heavy-duty applications: U.S. Pat. No. 2,338,817 which issued Jan. 11, 1944; U.S. Pat. No. 2,461,849 which issued Feb. 15, 1949; U.S. Pat. No. 3,703,321 which issued Nov. 21, 1972; and U.S. Pat. No. 4,241,956 which issued Dec. 30, 1980. The 'U.S. Pat. No. 849 patent which is assigned to B. F. Goodrich explained why positive drive was preferred over others: "It has also been proposed to eliminate the use of cross bars and to drive the track by friction alone, but use of such a construction requires a great area of angular contact or 'wrap' about the driving wheel and confines the use of such tracks to drives for light vehicles providing great angular contact of the drive wheel."

Notwithstanding the 'U.S. Pat. No. 849 recommendation, still other U.S. patents sought to apply friction drive to heavy-duty applications: U.S. Pat. No. 2,476,828 issued Jul. 19, 1949; U.S. Pat. No. 2,476,460 issued Jul. 19, 1949; U.S. Pat. No. 2,998,998 issued Sep. 5, 1961; U.S. Pat. No. 1,411,523 issued Apr. 4, 1922; U.S. Pat. No. 2,537,745 issued Jan. 9, 1951; U.S. Pat. No. 2,531,111 issued Nov. 21, 1950; U.S. Pat. No. 2,494,065 issued Jan. 10, 1950; U.S. Pat. No. 2,429,242 issued Oct. 21, 1947; U.S. Pat. No. 2,350,076 issued May 30, 1944; U.S. Pat. No. 2,898,965 issued Aug. 11, 1959; U.S. Pat. No. 2,644,539 issued Jul. 7, 1953; U.S. Pat. No. 3,369,622 issued Feb. 20, 1968; and U.S. Pat. No. 4,281,882 issued Aug. 4, 1981. Other friction drive systems are shown in Otter Tractor Corporation advertising circular, U.K. Patent 1,604,615 published Dec. 9, 1981; U.K. Patent 2,048,800B published Jan. 12, 1983; U.K. Patent 278,779 published Oct. 20, 1927; Netherlands Patent 7,605,810 published Nov. 30, 1977; and German Patent 678,785 granted Jun. 29, 1939. Many of the aforementioned friction drive systems have a dual purpose driving/guiding structure which utilizes a driving slot having sloped lateral facing side surfaces and a belt having cooperatively sloped, laterally facing side surfaces which are frictionally engaged with the slot's side surfaces through an interference fit similar to V-belt drives. The driving slots of such structures tend to accumulate debris which disengages the frictionally engageable side surfaces. Radial grooves in the walls bounding such slots have been used in attempts to expel debris from the slots but have been generally ineffective.

The aforementioned patents are representative of a large body of patents which purport to solve one or more of the belt system implementation problems. Such body of patents constitutes documentary evidence that efforts to achieve this blend of track and wheel propulsion systems have been exerted for over half a century without realizing any prac-

tical measure of success. Solutions to the problems of actually implementing a heavy-duty vehicular belt drive system have proven elusive and scientific scaling techniques have not, to date, been successfully applied to light duty vehicles for purposes of developing a heavy-duty belt system. Thus, despite the long felt need for and the advantages thereof, a heavy-duty application vehicle utilizing such belt system is commercially unavailable today.

It is, thus, the objective of this invention to provide a workable solution to the problems by taking into account that such vehicle's undercarriage, to be truly useful, should be roadable, provide high traction and low ground compression, and minimally disturb the underlying terrain, as well as operate in the heavy-duty working mode and provide a smooth ride for the operator in most soil conditions and topography from level land to steep inclinations while performing useful work without breaking the belts, losing drive capability between engaged wheels and belts, or disengaging the belts from the wheels.

SUMMARY OF THE INVENTION

The present invention generally includes a chassis, a pair of longitudinally spaced wheels arranged on each lateral side of the chassis in supporting relation thereto, and endless belt having an elastomeric exterior surface and being highly tensioned to provide frictional coupling between an interior surface thereof and the outer periphery of at least one wheel of each pair, and guide apparatus for maintaining lateral registry between each belt and the associated wheels. The belt tension is regulated by a tensioning apparatus which maintains the frictional coupling, accommodates debris ingestion between the belt and wheels without damaging either, and augments the guide apparatus in maintaining lateral belt to wheel registry. The belts are longitudinally reinforced to permit their high degree of tensioning and are laterally and transversely reinforced to resist movement in those directions and further augment the guide apparatus in retaining lateral registration.

Brief Description of the Drawings

The advantages of the present invention will become apparent from the following description when read in conjunction with the accompanying drawings in which:

FIG. 1 is a side elevation view of the work vehicle;

FIG. 2 is a front elevation view of the work vehicle illustrated in FIG. 1;

FIG. 3 is a plan view taken along line III—III of FIG. 1;

FIGS. 4 and 5 are respective sectional views of a preferred and an alternate belt construction;

FIGS. 6, 7, and 8 are respective partial sectional views of a preferred, first alternate, and second alternate drive wheel structure;

FIG. 9 is a partial sectional view of a preferred idler wheel structure;

FIG. 10 is a partial sectional view taken along line X—X of FIG. 2;

FIGS. 11A and 11B are diagrammatic views of belt portions respectively defining "lateral" and "transverse" flexibility;

FIGS. 12A, 12B, and 12C are diagrammatic, partial sectional views of an engaged driver wheel-belt structure subjected to varying lateral loads;

FIG. 13 is a graphical representation of belt/wheel structure lateral load carrying as a function of deformation thereof;

FIGS. 14A, 14B, 14C, 14D, 14E, and 14F are diagrammatic representations of the relative operational configurations of a bias tire/belt and a rigid or cushioned wheel/belt and wear characteristics exhibited thereby;

FIG. 15 is a graphical representation contrasting the present invention's mean power efficiencies with 4-wheel drive vehicle's mean power efficiencies for different soil/soil conditions; and

FIG. 16 is a graphical representation of the pull/weight ratio as a function of the propulsion system's slip percentage for the present invention and a 4-wheel drive vehicle.

DESCRIPTION OF THE PREFERRED EMBODIMENT

In general, the greatest problems encountered in providing a belt-over-wheel propulsion system for heavy-duty application are:

- (1) Maintaining lateral registry between each belt and its entrained wheels when the utilizing vehicle is subjected to high lateral loads;
- (2) Maintaining a driving relationship between the driver wheel(s) and the entraining belt; and
- (3) Accommodating debris intrusion between each belt and its entrained wheels without damaging either.

Solutions to the aforementioned problems will be discussed in conjunction with the structure providing such solutions.

Referring now to the drawings in detail, FIG. 1 illustrates an exemplary belt laying work vehicle 10 having a chassis 12 with a longitudinal axis 14 and a propulsion system 16 which resides generally beneath and in supporting relation to a frame 18 which, together with an operator's station 20 and an engine 22, constitutes the chassis 12. A rearwardly protruding drawbar 23 is joined to the frame 18 and constitutes an attachment structure to which draft loads may be connected. Although the exemplary work vehicle 10 constitutes a heavy-duty draft vehicle, the principles inherent in such exemplary structure are applicable to heavy-duty propulsion systems for other vehicles whether such vehicles are used for hauling, pushing, or pulling large loads. The illustrated draft work vehicle 10 was chosen as the exemplary apparatus since it has been actually reduced to practice and tested in a wide range of soil conditions, topographies, and loading characteristics.

The propulsion system 16 includes two pairs of longitudinally spaced apart wheel structures 24,26 which are arranged on opposite lateral sides 28,30 of the vehicle chassis 12 and which have respective radially outwardly facing peripheral surfaces 32,34, a pair of endless, substantially inextensible belts 36 each having an interior 38 and an exterior 40 surface which are respectively engaged with the wheel's outer peripheral surfaces 32,34 and the underlying terrain, and a roller support system 42 which is joined to the frame 18 on each lateral side of the chassis 12 and which is engageable with each belt's interior surface 38 longitudinally between the separated wheel structures 24,26 of each pair. The endless characteristic of the belt 36 means that the belt is continuous and has no connection joint(s).

Inasmuch as the propulsion system 16 has substantially identical components on each lateral side 28,30 of the chassis 12, further reference will only be made to the set of components on the side 28. At least one of the wheel structures on each lateral side of the chassis 12 constitutes a driver wheel structure 44 which frictionally transmits power to the belt 36 from the chassis-mounted engine 22. The wheel structures 24,26 on each side are laterally aligned and

have respective circumferential guide channels **46,48** which are each laterally bounded by positioning surfaces **50,52** and are adapted for receiving belt-resident guide structures. In the illustrated embodiment, the other wheel structure on each side constitutes an idler wheel structure **54** which helps to support the vehicle chassis **12**, cooperates with the driver **44** to provide a path **56** along which the belt **36** can be driven, and, in the illustrated case, provides a measure of recoil capability. For purposes of the present invention, however, the front wheel structure **26** could also constitute a driver. The rear wheel structure **24** of the illustrated draft vehicle constitutes the driver wheel structure **44** and the front wheel structure **26** constitutes the idler wheel structure **54**. The rear **24** and front **26** wheel structures are respectively mounted on laterally protruding axles **58,60** so as to rotate about respective axes **62,64** during vehicle movement.

The driver wheel structure **44** has arcuately spaced, laterally extending grooves **68** distributed in its outer peripheral surface **32**. Each pair of adjacent grooves **68** defines an intermediate protruberance **70** having arcuately bounding walls or edges **72,74** of desired radial height **76** and an outwardly facing drive portion **77** of predetermined arcuate length **78** which constitutes the outer peripheral surface **32**. "Leading" and "trailing" as used herein refers to the relative positioning of like elements during movement thereof. If the frictional couple between either drive wheel **44** and its associated belt **36** is lost as a result of mud or other friction reducing material intruding therebetween, that driver wheel **44** will rotate relative to the interior surface **38** of the belt **36** so as to cause the leading bounding wall, **72** or **74** depending on direction, of each engaged protuberance **70** to wipe that material from the belt's interior surface **38** into the groove **68** leading each protuberance **70**. Such relative rotation continues for short duration, typically less than 90°, until a sufficient part of the belt's interior surface **38** has been cleaned to re-establish the driving frictional couple. Such friction reducing material, subsequent to its deposition into the grooves **68**, is transmitted by those grooves **68** generally laterally and returned to the environment.

For frictionally coupling the driver wheel **44** with the belt **36**, the maximum surface area for torque transmission therebetween is desired and thus the surface area corresponding to grooves **68** in the driver **44** should be minimized. Use of a single groove **68** requires the driver wheel **44** to rotate nearly one revolution relative to the belt **36** to wipe the torque transmitting area of the belt **36** and thus reestablish the frictional coupling between the belt **36** and driver **44**. Such extreme amounts of relative motion results in reduced vehicle productivity, intermittent vehicular movement, and operator discomfort. Moreover, the resultant single groove would have to be very large to effectively conduct the debris wiped from the remainder of the wheel-belt interface. On the other hand, a large number of small grooves **68** would maintain the maximum surface area of frictional torque transmission and avoid the aforementioned disadvantages. However, a minimum cross-sectional area of each groove is necessary to effectively transversely conduct the wiped debris. It has been found that such minimum cross-sectional area has a minimum radial height **76** of about ½ inch. Operational experience indicates that for effective debris conduction, the arcuate length of the grooves **68** need not be greater than the protuberances' arcuate length and should be the minimum consistent with effective conduction of wiped debris. The protuberances **70** will not, for known compounds of rubber and for the tensions required to frictionally couple the belt and drive wheels, effectively transmit torque if their aspect ratio of arcuate length **78** to

radial length **76** is less than about 1:1. For practical sized wheels, however, such aspect ratio is preferably not less than about 3:1.

While the illustrated grooves **68** are arranged in the driver **44** at substantially 90° to the chassis' longitudinal axis and have radially oriented bounding walls **72,74**, it is to be understood that the grooves **68** could be formed in the belt's interior surface **38** and that other angular arrangements of the grooves **68** and other wall orientations are operationally acceptable for purposes of the present invention. The "grooved" configuration thus provides a substantial contribution in maintaining the driving relationship regardless of the environment.

As illustrated in FIGS. 1, 2, and 3, the front wheel structure **26** has a smooth outer peripheral surface **34** about which the belt **36** is entrained and engaged. Inasmuch as the front wheel structure **26** in the illustrated embodiment constitutes an idler **54**, maintaining a friction couple between it and the entraining belt's interior surface **38** is unnecessary.

The interior surfaces **38** of the endless, inextensible belts **36** illustrated in FIGS. 1, 2, and 3 constitute elastomer and are smooth to facilitate frictional engagement thereof with the associated driver **44** while the exterior surfaces **40** have elastomeric cleats **80** protruding therefrom for penetrating the underlying ground and enhancing the belt's tractive capability. The elastomeric character of the cleats **80** permits the illustrated vehicle **10** to travel on improved road surfaces without damaging same. The belts **36** preferably have an ultimate elongation of less than 5% to permit tensioning thereof with reasonable movements of tensioning apparatus and must be capable of sustaining tension loads of approximately 17,000 Newtons per lateral centimeter of belt width to provide the driving friction force typically transmitted by heavy-duty vehicles weighing in excess of about 4,500 Kilograms. As illustrated in FIGS. 1 and 3, each belt **36** has a guide structure **82** which is receivable in the wheels' guide channels **46,48** for maintaining lateral registry between each belt **36** and its entrained wheel structures **24,26**. Each guide structure **82** includes alignment members **84** which are longitudinally separated, by way of example, by about 5.5 centimeters, preferably extend inwardly from the lateral center of the associated belt's interior surface **38**, and have a high modulus of elasticity.

The rear **24** and front **26** wheel structures are relatively rigid in the lateral direction as compared to radial tires so as to promote belt guiding thereon for heavy-duty vehicle operation on side slopes or in other circumstances where the vehicle is subjected to high lateral loading. Due to the character of the exemplary draft vehicle **10** and for reasons to be discussed later relating to wear, greater lateral rigidity of the driver wheel structure **44** is required than of the idler wheel structure **54**. The preferred driver wheel structure **44** constitutes a cushioned wheel structure **85** which is illustrated in FIG. 6, and includes a circular rigid metal drum **86** having a solid layer **90** of elastomer which is radially thin relative to the drum's diameter and which is bonded to the drum's outer periphery **92**. By way of example the elastomer layer's radial thickness is about 5 centimeters and the drum's radius is about 51 centimeters. The material removing, friction enhancing grooves **68** previously described are resident in the elastomer layer **90**. The circumferential guiding channel **46** is arranged about the cushioned wheel structure **85** generally along its mid-circumferential plane **93** to expose opposed inner edges **94** of the elastomeric layer **90** and opposed inner margins **95** of the drum **86**. The guiding channel **46** is defined by the

laterally opposed positioning surfaces **50,52**, each of which includes a base portion **96** and an inner portion **98** which, by way of example, have respective angles of inclination **97** of approximately 90° and 106° . The base portions **96** constitute the inner edges **94** of the elastomeric layer **90** and the inner portions **98** constitute the inner margins **95** of the drums **86**. Such inner portions **98** preferably converge in a radially inward direction.

An alternative to such cushioned driver wheel structure **85** is a rigid wheel structure **100** which includes a completely rigid circular drum **86** as illustrated in FIG. 7. Friction enhancing grooves **68** in the rigid wheel structure's outer periphery provide the same material expulsion capability as do the grooves **68** in the elastomeric layer **90**. The cushioned driver wheel structure's elastomeric layer **90** cooperates with the belt's interior elastomeric surface **38** to envelop in a non-penetration mode any hard, non-flowable elements such as stones which become sandwiched between the wheel structures **24,26** and entrained belt **36**. The rigid driver wheel structure **100** also includes a circumferential guiding channel **46** laterally defined by positioning surfaces **50,52**. The completely rigid wheel structure **100** requires additional elastomeric material on the interior of a mating belt structure **36** which is suitable for use with the cushioned wheel structure **85** so as to provide the same propulsion system capacity to envelop and absorb non-flowable debris without sustaining belt penetration. The embodiment of FIG. 6 wherein the cushioning elastomeric layer **90** is arranged on the outer periphery of the drum **86** and on the interior surface of the belt **36** is less costly, requires less total elastomeric substance, and maintains greater longitudinal flexibility for the belt **36** than utilizing, in combination, a rigid driver wheel **100** and thicker, debris enveloping belt.

FIG. 8 illustrates another alternative driver wheel structure **44** which constitutes a pneumatic wheel structure having a pair of laterally separated pneumatic wheels **104, 106** which respectively include rigid rims **108,110** and inflatable, bias belted carcasses **112,114** mounted thereon. The bias belted carcasses **112,114** have laterally facing adjacent sidewalls **116,118** which are substantially parallel and preferably each have an angle of inclination **97** of 90° relative to the outer peripheral surface **32** thereof. The sidewalls **116,118** respectively include positioning surfaces **50,52** which define the circumferential guide channel **46**. Unlike conventional carcasses, the sidewalls **116,118** of the carcasses **112,114** are thicker and more planar to respectively provide greater lateral rigidity and better positioning surfaces **50,52** for engagement with the guide structure **82** with minimum surface area. Radial tire carcasses have insufficient rigidity in the lateral direction to provide the guiding required in all heavy-duty applications but the bias carcasses **112,114** will, in certain heavy-duty applications, such as motor grader vehicles, provide the requisite lateral stiffness. The lateral stiffness of the driver wheels **44** is an important factor in maintaining lateral registry of the belt **36** and wheels **24,26**.

The outer periphery **32** of the alternate pneumatic driver wheel structure **102** constitutes circumferentially alternating friction enhancing grooves **68** and protuberances **70** whose structure is the same as that shown for the driver wheel structures **44** illustrated in FIGS. 6 and 7. Both the cushioned **85** and rigid **100** driver wheel structures are preferred over the pneumatic carcass driver wheel structure **102** for applications in which pantographing and/or relative motion between the wheel driver structure **44** and belt **36** cannot be tolerated and still provide reasonable wear. Other than the well-known pantographing which all bias tires experience,

bias tires, when under load, also exhibit a phenomenon of tracing out a footprint for one revolution thereof which is shorter by approximately 2%–3% than is the circumference around such tire's outer periphery when unloaded. Such circumferential changing phenomenon causes relative motion between each belt's interior surface **38** and the protuberance's drive portions **77**. Such motion results in wear of the leading edge **72** (for forward vehicle motion) of the protuberances **70** and thus reduces the arcuate length of their drive portions **77**. The practical effect of such wearing substantially reduces the-wiping action of the protuberances **70** on the interior surface **38** of the belt **36** which, in turn, reduces the friction coupling between the drive wheel surfaces **44** and the belt **36** when they are operated in mud or other adverse, friction coefficient reducing environments. Such relative bias wheel-to-belt motion during frictional engagement is illustrated in FIG. 14A where, for purposes of illustration, only one lateral groove **68** and associated protuberance's leading edge **72** are illustrated at the left side of FIG. 14A with the leading edge **72** being in circumferential alignment with a belt mark arrow **120** which marks the matching position of the belt **36**. The right side of FIG. 14A illustrates the relative positioning of the belt mark **120** and the protuberances' leading edge **72** after rotation of the bias wheel in the indicated direction. The belt marker **120** moves a further linear distance than did the protuberances' leading edge **72** so as to demonstrate the relative movement therebetween. FIG. 14B illustrates the principle that when such bias wheel is rotated under load for one revolution, it moves a linear distance A which is less than the bias wheel's circumference B when unloaded. The resulting wear of the protuberance's leading edge **72** is respectively shown in FIG. 14C.

FIGS. 14D and 14E illustrate the lack of relative movement between an entraining belt **36** and a cushioned **85** or rigid **100** wheel structure as respectively shown in FIGS. 6 and 7. The rigid **100** or cushioned wheel **85**, when rotated one revolution under load, traverses a linear distance C, as diagrammatically illustrated in FIG. 14E, which is substantially equal to its unloaded circumference B. No relative movement between the driver's outer periphery **32** and the entraining belt **36** occurs during driver rotation as is sequentially illustrated in FIG. 14D. Accordingly, the leading edge **72** of the single illustrated protuberance **70** exhibits little wear, retains the shape illustrated in FIG. 14F, and maintains its belt wiping capability.

FIG. 9 illustrates the preferred embodiment of the idler wheel structure **54** and constitutes a pair of inflatable pneumatic wheels **104,106** which are similar to those shown in FIG. 8, but lack the lateral, friction enhancing grooves. The lateral separation space or circumferential guiding channel **48** between the wheels **104,106** is arranged along the wheel structure's mid circumferential plane **107** and is bounded and defined by the adjacent, laterally facing positioning surfaces **50,52** which cooperate to provide belt-to-wheel guiding. The work vehicle **10** illustrated in FIG. 1 is primarily intended for agricultural use and thus requires a limited but finite recoil capacity for cases where debris of a specified size may intrude between either of the wheel structures **24,26** and the belt **36**. The pneumatic idler wheel structure **54**, due to its ability to elastically deform, inherently provides the degree of recoil necessary to accommodate debris normally encountered in most agricultural applications while continuing to function and without overstressing the belt, wheels, or support structure for the wheels. Such recoil capability is a contributing factor in non-destructably accommodating debris intrusion.

FIGS. 4 and 5 respectively illustrate the presently preferred belt structure 122 and an alternative belt structure 124. The preferred belt structure 122 includes an elastomeric interior surface 38, an elastomeric exterior surface 40, and a pair of lateral sides 126,128 which respectively engage the wheel structures' outer peripheries 32,34, the underlying terrain, and bound the interior 38 and exterior 40 surfaces. The preferred belt 122 has a body portion 130 which is defined by the interior 38 and exterior 40 surfaces and by the lateral edges 126,128 and has a central plane 132. The guide structure 82 joined to and protruding interiorly from the belt's interior surface 38 constitutes elastomeric material and is receivable in the wheels' guiding channels 46,48 to maintain lateral registry therewith. The longitudinally separated alignment members 84, better illustrated in FIG. 1, each have a pair of opposed, generally laterally facing locating surfaces 134 and a tip surface 136. Each locating surface 134 has a base portion 138 and an inner portion 140 which have respective exemplary angles of inclination 97 of approximately 94° and 110° relative to the laterally adjacent portion of the interior surface 38. The locating surfaces' base portions 138 are radially co-extensive with the guide channel's base portions 96. By way of example, the height of the base 138 and inner 140 portions perpendicular to the interior surface 38 are about 5 and 10.2 centimeters, respectively. Each alignment member 84 has, by way of example, a lateral width 141 of about 11.2 centimeters and a longitudinal length of about 15.2 centimeters. The cleats 80 are attached to the exterior surface 40 of the belt body portion 130 and extend exteriorly therefrom.

A belt reinforcing structure includes at least one inextensible reinforcing filament 142 which is wrapped longitudinally in the body portion 130 from one lateral side 126 thereof to the other lateral side 128 such that when the belt 122 is installed on the wheel structures 24,26, each circumferential wrap or turn 143 of the filament 142 is substantially parallel to the chassis' longitudinal axis 14. The reinforcing filament is interiorly disposed within the body portion 130 and a pair of breaker plies 144,146, well-known in the art and constituting part of the reinforcing structure, are arranged in the body portion between the central plane 132 and the reinforcing filament 142. The breaker ply 144 adjacent the reinforcing filament is laterally more narrow than is the lateral extent of the filament wraps 143. The breaker ply 146 disposed adjacent the central plane 132 is, in turn, laterally more narrow than the other breaker ply 144. Each breaker ply 144,146 has stiffening fibers therein which are preferably arranged at 90° to the stiffening fibers in the adjacent breaker ply 144,146 and, in the installed position of the belt on the vehicle, are preferably oriented at 45° relative to the chassis' longitudinal axis 14. The reinforcing structure includes a plurality of longitudinally separated, laterally extending reinforcing elements 148 which are arranged in the body portion 130 on the opposite side of the central plane 132 from the reinforcing filament 142 and breaker plies 144,146.

The reinforcing filament 142 provides the belt 36 with its longitudinally inextensible yet flexible character which is necessary to resist undesired stretching of the belt 36 when it is subjected to the tension force necessary to frictionally couple it to the entrained driver wheel structure 44. Such longitudinal reinforcement allows, however, sufficient belt flexibility to readily conform to the outer peripheries 32,34 of the wheel structures 24,26 without diverting undue amounts of power from the vehicle's engine 22 for longitudinally conforming the belt to the wheel structure's outer peripheries. The bias plies 144,146 provide lateral stiffness

to the belt 122 while the lateral reinforcing elements 148 provide transverse stiffness to the belt 122 which are respectively necessary to resist the exemplary deformations depicted in FIGS. 11A and 11B of a schematically illustrated belt. The lateral belt stiffness resists "snaking" as illustrated in FIG. 11A and cooperates with the wheel structures 24,26 in maintaining lateral registry therewith by resisting side loads imposed by the vehicle's chassis. The transverse stiffness provided by the reinforcing structure's lateral reinforcing elements 148 resists transversely imposed forces as illustrated in FIG. 11B, tends to promote the correct orientation of the belts' guide structure 82 for suitable reception in the guide channels 46,48, and contributes to maintaining the lateral registry between the belt 122 and wheel structures 24,26. Without such transverse stiffness, the belts 36 could assume the configuration illustrated in 11B causing the alignment members 84 to cock as shown and thus promote disengagement of the guide structure 82 from its guide channels 46,48 and, thus, disengagement of the belt 36 from the associated wheel structures.

An alternate belt structure 124, illustrated in FIG. 5, has an interior surface 38, an exterior surface 40, and opposed lateral edges 126,128 which respectively engage the wheel structures' outer peripheries 32,34, the underlying terrain, and laterally bound the interior 38 and exterior 40 surfaces. The alternate belt structure 124 has a body portion 130 which is defined by the interior 38 and exterior 40 surfaces and the lateral edges 126,128 and has a central plane 132. The alternate belt has a reinforcement structure which includes at least one reinforcing filament 142 similar to that of FIG. 4 which is wrapped in the body portion 130 in a manner and location substantially identical to that of FIG. 4. A pair of breaker plies 144,146, of similar structure and orientation to the breaker plies of FIG. 4, constitute a portion of the reinforcement structure and are arranged between the reinforcing filament 142 and the belts' exterior surface 40 in a similar manner to those of FIG. 4. The reinforcement structure of the alternate belt construction 124 lacks the reinforcing elements 148 of FIG. 4 but, for some applications, provides a satisfactory extent of transverse rigidity. The guide structure 82 of FIG. 5 is identical to that of FIG. 4 and is joined to the alternate belt 124 in a manner and location identical to that of the preferred belt 122. It is to be understood that the longitudinal filament 142 is illustrated by example only and that more filaments could be wrapped in parallel or that multiple filaments could be wrapped in an end-to-end manner rather than each filament 142 being continuous for the entire belt.

FIG. 3 illustrates a partial cutaway view of a portion of the propulsion system 16. The center portion of the top belt run has been removed to expose the cooperative arrangement of the belt 36 and entrained wheel structures 24,26. The front 26 and rear 24 wheel structures have respective mid circumferential planes 107,93 which are preferably aligned along a common longitudinal path 150 which is parallel to the chassis' longitudinal axis 14. The circumferential guiding channels 46,48 on the rear and front wheel structures lie along the path 150 so as to promote entry therein of the belt's guide structure 82.

As best illustrated in FIGS. 1 and 3, the roller support-system 42 distributes a portion of the weight and load imposed on the vehicle frame 18 to the belt's interior surface 38 longitudinally between the entrained wheel structures 24,26. The roller support system 42 includes a mounting structure 152 which is pivotally connected to the frame 18 about a mounting axis 154, a leading 156 and a trailing 158 support arm connected to the mounting structure 152 and

adapted to rotate about the mounting axis **154**, a leading **160** and a trailing **162** connection structure which are respectively pivotally mounted on the leading **156** and trailing **158** support arms, two pair of roller structures **164,165** which are rigid in all directions and which are respectively rotatably mounted on the connection structures **160,162**, and a force reaction structure **166** for biasing either support arm **156,158** increasingly toward the belt's interior surface **38** in response to the belt's interior surface **38** being increasingly biased toward the other support arm **156,158**. The biasing structure **166** includes a force transfer member **168** which is preferably pivotally connected to the mounting structure **152** about the mounting axis **154** and a resilient structure **170** such as rubber springs or inflatable air bags arranged between the force transfer member **168** and each support arm **156,158** for biasingly transmitting forces exerted on the force transfer member **168** by one support arm to the other support arm. Each roller structure **164** constitutes a pair of laterally separated roller elements **172** which are rollingly engaged with the belt's interior surface **38** on the lower belt run. The separation distance between laterally adjacent roller elements **172** constitutes a guide slot **174** which is laterally aligned with the associated circumferential guide channels **46,48**. The belts' guide structures **82** longitudinally-traverse the guide path formed by the wheel structure' circumferential guide channels **46,48** and the roller structures' guide slots **174**. By virtue of the guide structures' residence in the guide slots and channels, lateral registry of the belt **36** with the associated wheel structures **24,26** and roller structures **164,165** is assured.

Frictional coupling of the drive wheel **44** structure and entraining belt **36** requires biasing the belt into engagement with the driver wheel structure **44** with a normal force which, when multiplied by the coefficient of friction therebetween, is at least as great as the force which the engine **22** can exert on the ground through the belt **36** if a positive drive system was provided. Each belt **36** is tensioned by separating the longitudinally distal portions of the cooperating front **24** and rear **26** wheel structures. Common means for separating such longitudinally distal wheel structure portions include inflating the pneumatic carcasses **112, 114** of the entrained wheel structures **24,26** and biasing the cooperating wheel structures **24,26** longitudinally apart either through wheel movement on their mounting axles or longitudinally separating the mounting axles **58,60**. If, as previously described, sufficient recoil capability is provided by one pneumatic wheel structure such as **54** in each cooperating pair **24,26**, the front wheels' pneumatic carcasses **112,114** can provide such recoil as well as tensioning the belts **36**.

If, however, pneumatic wheel structures such as **54** provide insufficient recoil capability or both cooperating wheel structures **24,26** need be rigid, additional recoil capability becomes necessary. Accordingly, in addition to the pneumatic front wheel structure **54**, a recoil/tensioning apparatus **176** was separately provided and is shown in FIG. **10**. The front axle **60** of the exemplary work vehicle **10** is pivotally mounted on the frame **18** through a sliding spherical bearing **178** about a pivot pin **180** which defines a longitudinal pivot axis **182** which is parallel to the chassis' longitudinal axis **14**. The front axle **60** includes a frame mounted base portion **184** and two extension portions **186** which are each pivotally mounted at an intermediate region thereof to the base portion **184** about an adjustment pin **188**. Only one extension portion **186** is shown since the extension portions are identical and are mounted on opposite lateral ends of the base portion **184**. Each axle extension portion **186** has a

laterally outwardly protruding wheel mounting region **190** on which a front wheel structure **26** is mounted and an adjustment region **192** which protrudes inwardly and is connected to a "toe in—toe out" apparatus **194** for adjusting the orientation of the front wheel structures' mid circumferential plane **107**. A strut **196** for tensioning the belt **36** connects the axle **60** at the adjustment pin **188** to a foundation member **198**. The adjusting apparatus **194** includes a screw bolt **200** which threadably joins the axle adjustment region **192** to the strut **196**.

A pair of hydraulic cylinders **202** each have a rod end **204** and a head end **206** which are respectively connected to the foundation member **198** and a thrust block **208** which is longitudinally slideable on the foundation member **198**. A retainer **210** is positioned vertically adjacent the thrust block **208**, extends laterally adjacent the foundation member **198**, and is joined to the thrust block **208** by a screw bolt **212**. Four retainer/screw bolt combinations **210,212**, one above and one below at each lateral end of the thrust block **208**, are utilized with the present invention. The thrust block **208** is pivotally mounted on the frame **18** by a swivel pin **214** which is coaxial with the pivot pin axis **182**. To accommodate applications where insufficient recoil is provided by one or more pneumatic wheel structures such as **54**, where the wheel structures and/or axles cannot be accurately located or precisely oriented to ensure accurate correlation between inflation pressure and the desired engagement pressure, or where the inextensible belt **36** cannot be installed or removed from the entrained wheel structures **24,26** simply by deflating the pneumatic wheels due to interference of the guide structure **82** with such deflated pneumatic wheels, it is believed to be more effective, less costly, and operationally of greater practicality to provide a separate mechanism such as the present invention's axle movement/belt tensioning system **176**. Such tensioning system provides a substantial contribution to enabling debris ingestion without damaging vehicle components.

The alignment members **84** sequentially pass through an alignment phase and a load carrying phase during their residence or partial residence in the wheel structures' guide channels **46,48** and the roller structures' guide slot **174**. The alignment phase begins when the inner locating surface portions **140** of the alignment members and the base positioning surface portions **50,52** move into lateral adjacent relationship. Lateral alignment of the wheel or roller structures and the alignment members **84** is provided by the progressive entry of the alignment members **84** into the guide channels **46,48** and guide slot **174**. If misaligned, the appropriate base positioning surface portion **50,52** serially engages the adjacent inner **140** and base **138** positioning surface portions to initially induce lateral deformation of the alignment members **84** which deformation decreases with increasing entry to cause relative lateral displacement of the alignment members **84** and the wheel or roller structures. The load carrying phase begins upon complete entry of the alignment members **84** in the guide channels **46,48** and slot **174** and continues until alignment members **84** exit therefrom. Discussion herein of the guide structure **82**'s interaction with the wheel and roller structures is limited to the load carrying phase of engagement therebetween.

FIGS. **12A, 12B,** and **12C** illustrate cross-sectional views of the relative configuration of the preferred driver wheel structure **84** and the entraining belt **36** for increasing degrees of side force exerted by the wheel structure **85** on the belt **36**. FIG. **12A** illustrates the engaged wheel structure and entraining belt for linear movement of the vehicle **10** on terrain having no side slope. There is a running clearance at

the outer periphery 32 of the wheel structure 85 between laterally adjacent locating 134 and positioning 50,52 surfaces of approximately 0.3 centimeters. FIG. 12B illustrates the belt/entrained drive wheel structure 85 when the vehicle 10 is operated on a side slope of is making a turn. The respective base portions 138 and 96 of the guide structure's left locating surface and the wheel structure's right positioning surface 50 deform to provide surface engagement therebetween. The deformation illustrated in FIG. 12B is characteristic for most side hill conditions or vehicle turns and constitutes a radial distance of engagement therebetween of approximately 2½% of the wheel's diameter. FIG. 12C illustrates the belt/entrained driver wheel structure 85 when the utilizing vehicle 10 is making a turn on a steep side slope. The base portions 138,96 of adjacent left locating and right positioning surfaces have fully engaged but such surface engagement remains near the wheel structures' outer periphery since the lateral engagement area therebetween is within 5% of the wheel structures' outer periphery.

FIG. 13 is a graphical representation of the lateral loads which are supported by the guide structure 82 as a function of the guide structure's deformation. Numbers have not been placed on FIG. 13 because the load and deformation magnitudes are a function of the vehicle weight, the material characteristics of the drive wheel and entraining belt, and the relative size of the engageable positioning and locating surfaces. FIG. 13 is instructive, however, for purposes of noting the trend in guide structure/driver wheel deformation for increasing load. The configuration of FIG. 12A operates in the region designated 12A on FIG. 13 where there is no load and no deformation. The configuration illustrated in FIG. 12B operates at the point designated 12B on FIG. 13 where some limited locating surface/positioning surface deformation has been sustained in resisting the side load. The belt/driver wheel configuration illustrated in FIG. 12C occurs for the deflection and load indicated on FIG. 13 by the reference numeral 12C. For the configuration of FIG. 12C, the base portions of the elastomeric locating 134 and positioning 50 surfaces have become completely engaged and any more load exerted thereon will be resisted at a higher rate and lower deformation since the location surface's inner portion 140 will thereafter increasingly engage the inner portion 98 of the rigid drum's positioning surface 50. Such increased load acceptance for a given deformation is graphically represented by the relatively steeper slope on the load/deformation curve of FIG. 13 for loads and deformations greater than those corresponding to the point marked 12C.

Maintaining the friction couple between the driver wheel structures and associated belts minimizes the relative motion and reduces wear thereof. Insofar as engagement therebetween is limited to the radially facing driver wheel and belt surfaces, the wear problem does not exist. Maintaining lateral registry of the driver wheel 44 and belt 36 when lateral loads are exerted on either necessitates engagement between lateral surfaces of both. Such lateral surface engagement results in relative motion between the wheel and belt at the points on the wheel where the belt initially engages and disengages therewith. Between such points the lateral engaging surfaces either have no relative motion or are not engaged. At such points, however, the belt is moving in a linear mode while the mating wheel is rotating and relative motion between the laterally engaging surfaces is unavoidable. Increasing relative motion results at increasing radial distances from the wheel's outer peripheral surface 32. It is, accordingly, necessary to minimize the radial extent of lateral surface engagement and still provide lateral guid-

ing therebetween. The belt's alignment members 84 are laterally tapered in a convergent manner such that their locating surfaces 134 diverge from the adjacent positioning surfaces 50,52 to minimize the lateral surface contact therebetween but are not tapered to such an extent that the driver wheel 44 can easily "walk up" the side thereof and unbelt itself. Multiple alignment members 84 are used rather than a continuous member to avoid the elevated levels of compression on the innermost fibers thereof during belt conformance around the entrained wheel structures.

The bond between the elastomeric alignment members 84 and each interior surface 38 has been found to be more durable in operation than the bond formed between elastomeric belt bodies and metal guides partially encased therein and partially protruding therefrom. Inasmuch as vehicle mobility and maneuverability is directly affected by the guiding interaction between the alignment members 84 and the wheel structures, the reliability of the alignment member-belt bond is of critical importance to the operation of the present invention.

The lateral most passes of the belt's longitudinal filament(s) 142 are arranged laterally beyond the driver wheel's outer peripheral surface 32 with which the belt is engaged as illustrated in FIGS. 12A, 12B, and 12C. The purpose of such disposition is to lower the stresses imposed on those laterally outermost filaments when extreme amounts of debris are ingested between the belt 36 and wheels 24,26. Such outer filaments experience the highest stress levels because ingested debris typically has a wedge shaped cross section with the greatest thickness being at the lateral extremes of the belt 36. In the illustrated embodiment the driver wheel 44 is laterally tapered at its outer periphery 32, but an equally effective solution to such problem is to laterally extend the belt and longitudinal filaments beyond the lateral edges of untapered driver wheel structures. Both such arrangements contribute toward the goal of accommodating debris ingestion without damaging propulsion system components.

The data presented in FIG. 15 illustrates the projected relative mean efficiencies of 4-wheel drive agricultural tractors and the present invention belted vehicle 10 in four different soils/soil conditions. Efficiency is defined as the ratio (expressed as a percentage) of the vehicle's drawbar horsepower divided by engine horsepower. Mean efficiency is the average of the vehicle's peak efficiency and the efficiency corresponding to a pulling force 10% less than that exerted at the peak efficiency. Such mean efficiency is considered representative of the actual way an agricultural tractor is used. While it is to be understood that soils and their conditions constitute a continuum based on many factors such as moisture, ground compaction, etc. rather than the discrete classifications shown, such classifications are useful for illustrating the relative vehicular performance for the acreage segments in the United States now tilled with 4-wheel drive vehicles. Soils in other parts of the world exhibit similar characteristics and can be generally categorized into the illustrated classifications, but the existing percentage of each soil/soil condition classification, worldwide, is unknown. The belted vehicle's advantage, however, for the illustrated soil/soil condition classifications remain 8.0%, 11.0%, 27.0%, and 56.0%.

The firm, strong classification is generally represented by Midwest soil, refers to the soil's high resistance to vehicular sinking and high shear strength, and constitutes about 35% of the U.S. acres presently tilled by 4-wheel drive vehicles. The firm, weak classification generally represents Southwest oil, refers to the soil's high resistance to vehicular sinking

and low shear strength and constitutes about 30% of the U.S. acres now tilled with 4-wheel drive vehicles. The tilled classification is generally representative of any farmed soil which has already been plowed or otherwise tilled and constitutes about 25% of the 4-wheel drive-tilled acres in the U.S. The soft, weak classification is generally represented by any soil which is wet and loose, refers to the soil's low resistance to vehicular sinking and low shear strength, and makes up about 10% of the acres presently tilled in the U.S. by 4-wheel drive vehicles. The belted vehicle's advantage varies from 8.0% in firm, strong soil to 56% in soft, weak soil. In general, the softer and looser the soil, the greater will be the belted vehicle's advantage.

These projections are based on data gathered during experimental, side-by-side testing in a variety of soils and soil conditions of a 4-wheel drive agricultural tractor weighing about 14,900 Kg and having a nominal engine rating of 260 Kw and the belted vehicle weighing about 10,900 Kg and having a nominal engine rating of 180 Kw. The final results of one series of tests showed the belted vehicle to have tilled only 4% less ground in the same time period while consuming 26% less fuel than the 4-wheel drive tractor. Insofar as the subject belted vehicle engaged in the testing was an experimental prototype, the results, while dramatic, can be further improved.

Propulsion system "slip percentage" is defined as the following ratio expressed as a percentage: $100 - [(velocity\ of\ the\ vehicle) / (velocity\ of\ the\ propulsion\ system's\ ground\ engaging\ portion)]$. The maximum pull/weight ratio of 4-wheel drive vehicles varies with soil conditions, vehicle balance, load characteristic, etc., but generally corresponds to a slip percentage averaging about 20-40%, as compared to the belted vehicle, whose maximum pull/weight ratio generally corresponds to a slip percentage to about 8-15%. FIG. 16 diagrammatically illustrates a representative set of curves which show the belted vehicle developing its maximum pull/weight ratio at a substantially lower slip percentage than does the 4-wheel drive vehicle. Of course, higher rates of slip result in higher wear rates of all drive components, but most especially the ground engaging portions.

The belted and 4-wheel drive tractors exerted approximate respective ground pressures of 3.45 Newtons per square centimeter and 10.3 Newtons per square centimeter. While it is well-known that crops often grow faster in soils having little compaction as compared to soils having greater compaction, one agriculturist actually observed that crops grown in soil tilled by the belted vehicle grew faster than crops grown in soil tilled by the higher powered, heavier 4-wheel drive tractor.

Vehicle operators reported a smoother ride from the belted vehicle 10 as compared to the wheel tractor which improvement manifests itself in comparatively improved operator performance as the time of operation increases. The ride improvement is also indicative of reduced maintenance requirements of chassis mounted components since those components are isolated from impact loads which commonly occur in traversing uneven terrain.

It should now be apparent that an elastomeric belt laying vehicle 10 has been provided which traverses improved road surfaces at high speed without inflicting damage, which has superior tractive effort and low unit ground pressure as compared with comparably powered wheel vehicles, and which provides improved ride characteristics as compared with wheeled vehicles used in comparable conditions.

We claim:

1. A belt laying work vehicle comprising:
 - a frame having opposed lateral sides;
 - a pair of longitudinally separated wheel structures having radially outwardly facing outer peripheral surfaces and being mounted in supporting relation to said frame on each lateral side thereof and at least one of each pair including a driver;
 - a pair of endless, inextensible belts each having opposite lateral sides and an interior surface and each being entrained about a respective pair of said wheel structures, a plurality of laterally extending grooves being disposed on one of said interior surface and said outer peripheral surface of each belt and entrained driver, respectively, for removing debris from therebetween;
 - means for controllably tensioning and urging each belt's interior surface and said outer peripheral surface of the associated driver into frictional driven engagement;
 - means for distributing a predetermined portion of the weight of said frame to the interior surface of each belt longitudinally between said wheel structures of each pair;
 - means for rotating each of said drivers;
 - guiding means including interengaging portions of said wheel structures and entraining belt for minimizing lateral movement of each belt relative to the respective entrained wheel structures and for radially localizing lateral engagement of each belt and the respective entrained driver to locations substantially adjacent said outer peripheral surface; and
 - said driver wheel structure having a circumference which is maintained substantially constant during rotation and under driving load.
2. A belt laying vehicle, as set forth in claim 1, wherein said weight distribution means includes:
 - a mounting structure connected to said frame;
 - a first and second support arm pivotally connected to said mounting structure about a pivot axis;
 - a first and a second roller structure being respectively rotatably joined to said first and second support arms; and
 - means for biasingly transmitting forces exerted on one of said support arms by the roller structure joined thereto to the other roller structure through said other support arm.
3. A belt laying vehicle, as set forth in claim 2, wherein said guiding means includes a plurality of longitudinally separated alignment members, and each of said roller structures includes a pair of laterally separated rollers which define a guiding slot adapted for receiving said alignment members.
4. A belt laying vehicle, as set forth in claim 3, wherein each of said alignment members has a locating surface and is connected to and extends interiorly from a respective belt, and a positioning surface connected to each wheel structure and positioned laterally adjacent said locating surfaces.
5. A belt laying vehicle, as set forth in claim 2, wherein said means for biasingly transmitting forces includes a force transfer member pivotally connected to said mounting structure and a resilient structure arranged between said force transfer member and each support arm.
6. A belt laying work vehicle comprising:
 - a frame having opposed lateral sides;
 - a pair of longitudinally separated wheel structures being mounted in supporting relation to said frame on each

17

lateral side thereof and at least one of each pair including a driver having a laterally rigid drum and a radially thin layer of elastomer joined directly to said drum, each elastomer layer having a radially outwardly facing outer peripheral surface;

a pair of endless, inextensible belts each having opposite lateral sides and an interior surface and each being entrained about a respective pair of said wheel structures;

means for controllably tensioning and urging each belt's interior surface and said outer peripheral surface of the associated driver into frictional driven engagement;

means for rotating each of said drivers;

guiding means including interengaging portions of said wheel structures and entraining belt for minimizing lateral movement of each belt relative to the respective entrained wheel structures and for radially localizing lateral engagement of each belt and the respective entrained driver to locations substantially adjacent said outer peripheral surface; and

said driver wheel structure having a circumference which is maintained substantially constant during rotation and under driving load.

7. The belt laying vehicle of claim 6, including means for distributing a predetermined fraction of the weight of said frame to the interior surface of each belt longitudinally between said wheel structures of each pair.

8. The belt laying vehicle of claim 7, wherein said weight distribution means includes:

a mounting structure connected to said frame;

a first and second arm pivotally connected to said mounting structure about a pivot axis;

a first and a second roller structure being respectively rotatably joined to said first and second arms; and

means for biasingly transmitting forces exerted on one of said arms by the roller structure joined thereto to the other roller structure through said other arm.

9. The belt laying vehicle of claim 8, wherein each of said roller structures includes a pair of laterally separated rollers which define a guiding slot adapted for guidingly receiving said guide means' enterengaging belt portion.

10. A belt laying work vehicle comprising:

a frame having opposed lateral sides;

a pair of longitudinally separated wheel structures having radially outwardly facing outer peripheral surfaces and being mounted in supporting relation to said frame on each lateral side thereof and at least one of each pair including a driver;

a pair of endless, inextensible belts each being entrained about a respective pair of said wheel structures and including a body portion bounded by opposed interior and exterior surfaces and opposed lateral sides, said body portion having reinforcing structure disposed therein between said lateral sides, a plurality of laterally extending grooves being disposed on one of said interior surface and said outer peripheral surface of each belt and entrained driver, respectively;

means for controllably tensioning and providing a majority of a frictional driven engagement by urging each belt's interior surface and said outer peripheral surface of the associated driver into said frictional driven engagement;

means for rotating each of said drivers;

a plurality of longitudinally separated elastomeric alignment members joined to the interior surfaces laterally

18

between the lateral extremes of said reinforcing structure, said alignment members being laterally engageable with said wheel structures; and said drive wheel structure having a circumference which is maintained substantially constant during rotating and under driving load.

11. A belt laying work vehicle comprising:

a frame having opposed lateral sides;

a pair of longitudinally separated wheel structures having radially outwardly facing outer peripheral surfaces and being mounted in supporting relation to said frame on each lateral side thereof and at least one of each pair including a driver;

a pair of endless, inextensible belts each being entrained about a respective pair of said wheel structures and including a body portion bounded by opposed interior and exterior surfaces and opposed lateral sides, said body portion having reinforcing structure disposed therein between said lateral sides;

means for controllably tensioning and providing a majority of a frictional driven engagement by urging each belt's interior surface and said outer peripheral surface of the associated driver into said frictional driven engagement;

means for distributing a predetermined portion of the weight of said frame to the interior surface of each belt longitudinally between said wheel structures of each pair;

means for rotating each of said drivers; and

guiding means including interengaging portions of said wheel structures and entraining belt for minimizing lateral movement of each belt relative to the respective entrained wheel structures and for radially localizing lateral engagement of each belt and the respective entrained driver to locations substantially adjacent said outer peripheral surface, and said driver wheel structure being rigid and having a circumference which is maintained substantially constant during rotation under driving load.

12. The belt laying work vehicle of claim 11 wherein said wheel structure includes a laterally rigid drum.

13. The belt laying work vehicle of claim 11 wherein said means for distributing a predetermined portion of a weight of said frame includes:

a mounting structure connected to said frame;

a first and second support arm pivotally connected to said mounting structure about a pivot axis;

a first and second roller structure being respectively rotatable joined to said first and second support arms; and

means for biasingly transmitting forces exerted on one of said support arms by the roller structure joined thereto to the other roller structure through said other support arm.

14. A belt laying work vehicle comprising:

a frame having opposed lateral sides;

a pair of longitudinally separated wheel structures being mounted in supporting relation to said frame on each lateral side thereof and at least one of each pair including a driver having a laterally rigid drum and said drum defining a radially outwardly facing outer peripheral surface;

a pair of endless, inextensible belts each having opposite lateral sides and an interior surface and each being entrained about a respective pair of said wheel structures;

means for controllably tensioning and providing a majority of a frictional driven engagement by urging each belt's interior surface and said outer peripheral surface of the associated driver into said frictional driven engagement;

means for distributing a predetermined portion of the weight of said frame to the interior surface of each belt longitudinally between said wheel structure of each pair;

means for rotating each of said drivers;

guiding means including interengaging portions of said wheel structures and entraining belt for minimizing lateral movement of each belt relative to the respective entrained wheel structures and for radially localizing lateral engagement of each belt and the respective entrained driver to locations substantially adjacent said outer peripheral surface; and

said drive wheel structure being rigid and having a circumference which is maintained substantially constant during rotation and under driving load.

15. A belt laying work vehicle comprising:

a frame having opposed lateral sides;

a pair of longitudinally separated wheel structures having radially outwardly facing outer peripheral surfaces and being mounted in supporting relation to said frame on each lateral side thereof and at least one of each pair including a driver;

a pair of endless, inextensible belts each being entrained about a respective pair of said wheel structures and including a body portion bounded by opposed interior and exterior surfaces and opposed lateral sides, said body portion having reinforcing structure disposed therein between said lateral sides;

means for controllably tensioning and providing a majority of a frictional driven engagement by urging each belt's interior surface and said outer peripheral surface of the associated driver into said frictional driven engagement;

means for distributing a predetermined portion of the weight of said frame to the interior surface of each belt longitudinally between said wheel structures of each pair;

means for rotating each of said drivers;

guiding means including interengaging portions of said wheel structures and entraining belt for minimizing lateral movement of each belt relative to the respective entrained wheel structures and for radially localizing lateral engagement of each belt and the respective entrained driver to locations substantially adjacent said outer peripheral surface; and

said drive wheel structure being rigid and having a circumference which is maintained substantially constant during rotation under driving load.

16. A belt laying work vehicle comprising:

a frame having opposed lateral sides;

a pair of longitudinally separated wheel structures having radially outwardly facing outer peripheral surfaces and being mounted in supporting relation to said frame on each lateral side thereof and at least one of each pair including a rigid driver;

a pair of endless, inextensible, reinforced belts each having opposite lateral sides and an interior surface and each being entrained about a respective one of said pair of wheel structures;

a controllable tensioning apparatus including a cylinder arrangement operative to apply a force separating the longitudinally distal portions of each of said pair of longitudinally separated wheel structures providing a majority of a frictional driven engagement by urging each belt's interior surface and the outer peripheral surface of the pair of longitudinally separated wheel structures into said frictional driven engagement;

means for distributing a predetermined portion of the weight of said frame to the interior surface of each belt longitudinally between said wheel structures of each pair;

means for rotating each of said drivers;

guiding means including interengaging portions of said wheel structures and entraining belt for minimizing lateral movement of each belt relative to the respective entrained wheel structures and for radially localizing lateral engagement of each belt and the respective entrained driver to locations substantially adjacent said outer peripheral surface; and

said driver wheel structure being rigid and having a circumference which is maintained substantially constant during rotation under driving load.

17. The belt work vehicle of claim 16 further including a plurality of laterally extending grooves being disposed on one of said interior surface and said radially outwardly facing outer peripheral surface of each belt and each of said rigid drive wheel respectively.

18. An agricultural tractor, comprising:

a frame and an engine supported on the frame;

two pairs of longitudinally spaced wheels, apparatus mounting one pair of wheels on one side of the frame and the other pair on the other side, at least one of each pair including a rigid driver driven by the engine, each wheel having a generally circumferential outer peripheral surface, and each driver being so constructed and arranged that its circumference is maintained substantially constant during rotation under driving loads;

first and second endless, substantially inextensible, reinforced belts each having an interior surface and each being entrained about a respective pair of the wheels;

a plurality of longitudinally spaced rollers located between the wheels of each pair and engaged with the interior surface of the respective belt for distributing a portion of the weight of the tractor to the belt;

a guiding arrangement including interengaging portions of the wheels and entrained belt to minimize lateral movement of each belt relative to the wheels it is entrained about and to radially localize lateral engagement of each belt and its respective driver to locations adjacent the driver's outer peripheral surface; and

a tensioning apparatus including a pair of hydraulic cylinders each having a head end and a rod end and each operatively associated with a respective pair of wheels and their entrained belt to urge the wheels longitudinally further apart, thereby tensioning each belt's interior surface providing a majority of a frictional driven engagement with the outer peripheral surface of its respective driver.

19. The agricultural tractor of claim 18 further including a plurality of laterally extending grooves being disposed on one of said interior surface and said generally circumferential outer peripheral surface of each belt and each of said rigid drive wheel respectively.

20. A belt laying heavy-duty work vehicle, comprising:
 a frame having opposed lateral sides;
 a set of longitudinally separated wheel structures being
 mounted in supporting relation to said frame on each
 lateral side thereof, each of said set of wheel structures
 including a pair of wheels, said wheels having radially
 outwardly facing outer peripheral surfaces, at least one
 of said pair of wheels being a driver;
 a pair of endless, inextensible, reinforced belts each being
 entrained about a respective one of said pair of wheel
 structures and including a body portion bounded by
 opposed interior and exterior surfaces and opposed
 lateral sides;
 a tensioning apparatus including at least one hydraulic
 cylinder operatively associated with each set of wheel
 structures to regulate tension of each of the belts by
 urging the longitudinal separation of said pair of
 wheels of each of said longitudinally separated wheel
 structures maintaining each pair of belt's interior sur-
 face in driving relationship by providing a majority of
 a frictional driven engagement with the respective
 outer peripheral surface of the set of wheel structures;
 a set of rollers carried between each of said longitudinally
 separated wheel structures and disposed to engage the
 interior surface of each belt and to distribute a portion
 of the weight of said frame longitudinally between said
 pair of wheels of each of said wheel structures;
 means for rotating each of said drivers;
 a guide apparatus including a portion of said wheel
 structures that engages a portion of said entraining belt
 to minimize lateral movement of each belt relative to
 the respective entrained wheel structures, each wheel

structure portion and respective belt portion being
 located to radially localize lateral engagement of the
 respective belt and entrained driver to locations sub-
 stantially adjacent said outer peripheral surfaces of
 said wheel structures; and
 each drive being rigid and having a circumference which
 is maintained substantially constant during rotation
 under driving loads.
 21. The belt laying work vehicle of claim 20 wherein said
 tensioning apparatus applies a tension force necessary to
 frictionally couple said endless, inextensible belts and said
 respective drivers.
 22. The belt laying work vehicle of claim 21 wherein said
 tension force, when multiplied by the coefficient of friction
 between the drive wheel structure and the belts, is at least as
 great as the predetermined driving force which the engine
 can exert on the ground through the belts.
 23. The belt laying work vehicle of claim 21 wherein said
 pair of endless, inextensible belts have a width and said
 tension force is about 17,00 Newtons per lateral centimeter
 of belt width.
 24. The belt laying work vehicle of claim 20 wherein said
 tensioning apparatus is arranged to move each of said other
 wheels longitudinally away from its respective driver.
 25. The belt laying work vehicle of claim 20 wherein said
 tensioning apparatus includes a recoil apparatus.
 26. The belt laying heavy-duty work vehicle of claim 20
 further including a plurality of laterally extending grooves
 being disposed on one of said interior surface and said
 radially outwardly facing outer peripheral surface of each
 belt and each of said driver respectively.

* * * * *

UNITED STATES PATENT AND TRADEMARK OFFICE
CERTIFICATE OF CORRECTION

PATENT NO. : RE 37,174 E
DATED : May 15, 2001
INVENTOR(S) : Charles E. Grawey et al.

Page 1 of 1

It is certified that error appears in the above-identified patent and that said Letters Patent is hereby corrected as shown below:

Column 1,

Line 15, insert -- Notice: More than one reissue application has been filed for the reissue of patent 5,363,936. The reissue applications are 09/759,863, which is a continuation of 08/674,423. --

Signed and Sealed this

Fourteenth Day of September, 2004

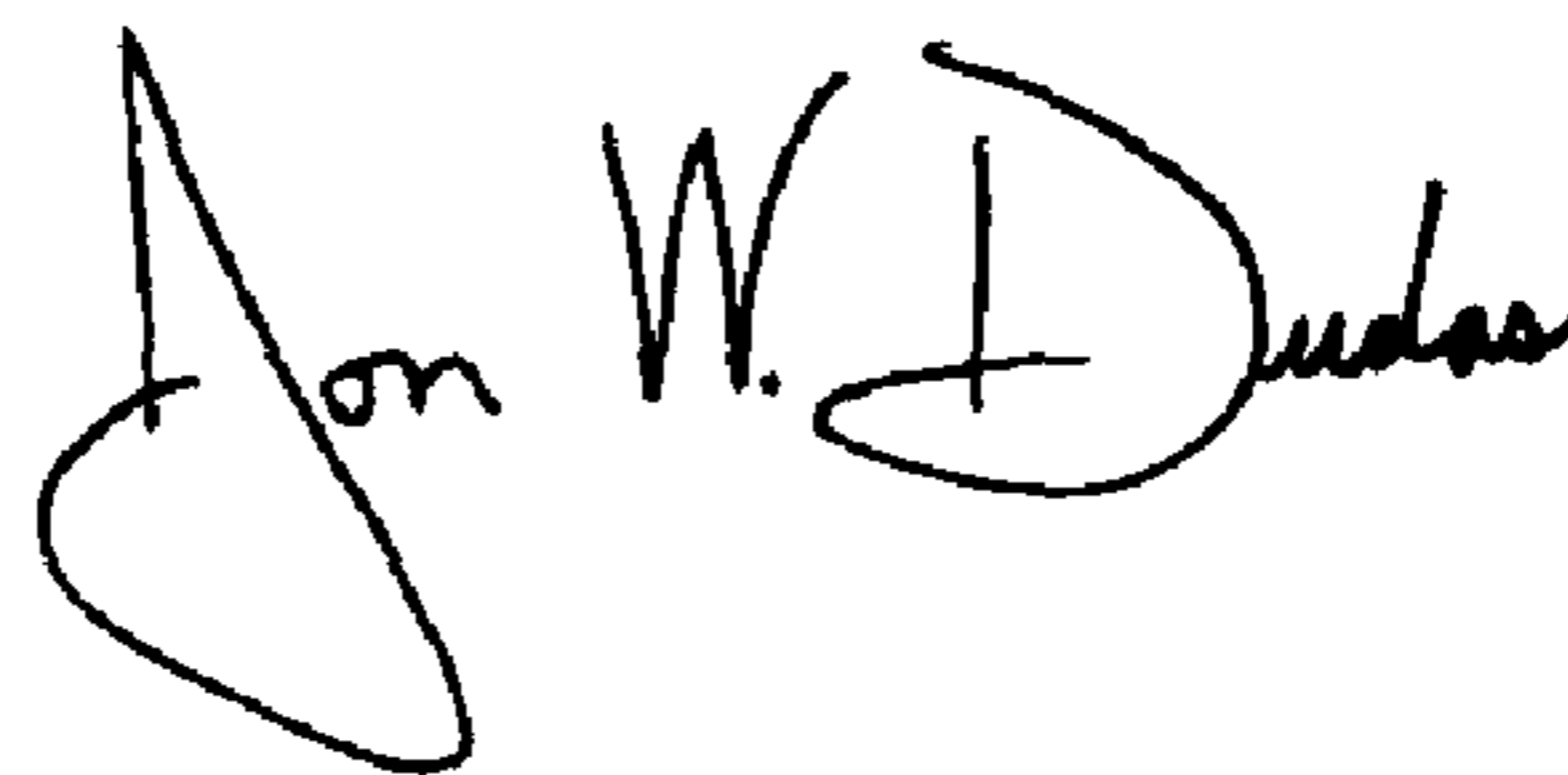
A handwritten signature in black ink that reads "Jon W. Dudas". The signature is written in a cursive style with a large, looped initial "J".

JON W. DUDAS
Director of the United States Patent and Trademark Office