



US00RE37114E

(19) **United States**
(12) **Reissued Patent**
Youngs et al.

(10) **Patent Number: US RE37,114 E**
(45) **Date of Reissued Patent: Mar. 27, 2001**

(54) **SECONDARY CONTAINMENT FLEXIBLE UNDERGROUND PIPING SYSTEM**
(75) Inventors: **Andrew Youngs, Granger, IN (US); Timothy A. Ashcraft, Dover, OH (US)**
(73) Assignee: **Advanced Polymer Technology, Inc., Muskegon, MI (US)**

1,375,363 4/1921 Cary et al. .
1,986,789 1/1935 Bennett .
2,013,193 9/1935 Stadfeld .
2,050,968 8/1936 Gottwald et al. .
2,093,114 9/1937 Sonnenfeld .
2,113,204 4/1938 Wasser .

(List continued on next page.)

FOREIGN PATENT DOCUMENTS

(21) Appl. No.: **08/770,734**
(22) Filed: **Dec. 19, 1996**

1425487 5/1969 (DE) .
0207015 6/1986 (EP) .
0343884 11/1989 (EP) .
1529813 10/1967 (FR) .
875224 8/1961 (GB) .
245418 4/1969 (SU) .
WO90/04157 4/1990 (WO) .
WO93/20372 10/1993 (WO) .

Related U.S. Patent Documents

Reissue of:
(64) Patent No.: **5,494,374**
Issued: **Feb. 27, 1996**
Appl. No.: **08/146,592**
Filed: **Nov. 1, 1993**

OTHER PUBLICATIONS

(51) **Int. Cl.**⁷ **F16L 57/00; F16L 11/12; F16L 11/20**
(52) **U.S. Cl.** **405/52; 73/40.5 R; 405/128; 405/154; 405/157**
(58) **Field of Search** **405/154, 52, 128; 138/121, 139, 151, 108-114, 125, 103; 73/40.5**

Enviroflex TM, The Flexible Double-Wall Piping System, Sep. 1990.
Supplementary European Search Report Dated May 27, 1994 for EPO Appln. No. EP 93909213.
A Verdier Sheet/Special Interrogatories From Civil Action No. 95-7209, E.D. Pennsylvania filed with the court Jul. 30, 1997.

Primary Examiner—Dennis L. Taylor
(74) *Attorney, Agent, or Firm*—Young & Basile, P.C.

(56) **References Cited**

U.S. PATENT DOCUMENTS

216,286 6/1879 Miller .
244,752 7/1881 Hunter et al. .
272,833 2/1883 Goodfellow .
286,938 10/1883 Martin .
291,715 1/1884 Greives et al. .
D. 309,308 7/1990 Webb .
D. 313,418 1/1991 Webb .
347,084 8/1886 Blackmore et al. .
430,010 6/1890 Flad .
470,946 3/1892 Munsie .
648,128 4/1900 Kinniburgh .
745,351 12/1903 Hungerford .
813,918 2/1906 Schmitz .
997,434 7/1911 Barnes .
1,188,446 6/1916 Haines .

(57) **ABSTRACT**

The secondarily contained piping system having two spaced access chambers that are interconnected by a secondary containment pipe to provide a sealed arrangement for a flexible fluid supply pipe, the ends of which are disposed within the access chambers. The outer flexible pipe is sized to permit the insertion and/or removal of the primary flexible pipe during installation and testing of the same and after backfilling of the trench within which the pipe is disposed, the outer flexible tubing partially collapses to engage and prevent relative movement between the two pipes while providing a flow path thereinbetween.

17 Claims, 5 Drawing Sheets

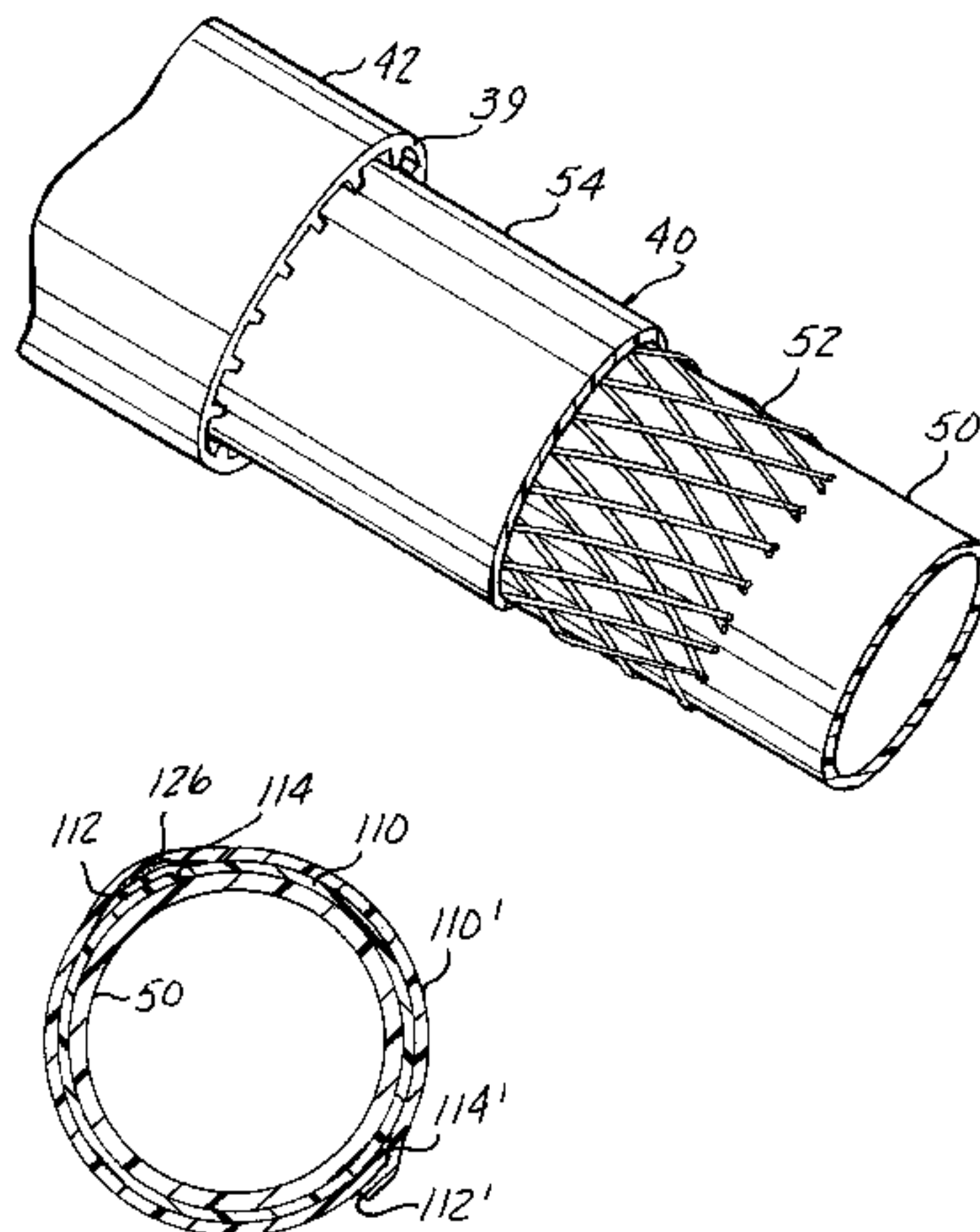

US RE37,114 E

Page 2

U.S. PATENT DOCUMENTS					
2,129,924	9/1938	Galbraith .	4,018,252	4/1977	Burtis et al. .
2,149,602	3/1939	Horvath .	4,020,641	5/1977	Takada .
2,306,331	12/1942	Elmer .	4,036,617	7/1977	Leonard et al. .
2,325,565	7/1943	Williams .	4,058,147	11/1977	Stary et al. .
2,336,150	12/1943	Horvath .	4,062,376	12/1977	McGrath .
2,347,912	5/1944	Komives .	4,090,525	5/1978	Potter .
2,487,939	11/1949	Norton .	4,098,298	7/1978	Vohrer .
2,507,597	5/1950	Holdridge .	4,098,308	7/1978	Purdum .
2,546,348	3/1951	Shuman .	4,100,758	7/1978	Mayer .
2,569,110	9/1951	McGillis et al. .	4,110,947	9/1978	Murray et al. .
2,573,366	10/1951	Scholl .	4,111,466	9/1978	Deregibus .
2,649,769	8/1953	Kaiser .	4,122,968	10/1978	Germain .
2,658,527	11/1953	Kaiser .	4,130,139	12/1978	Haren .
2,735,448	2/1956	Phelps, Jr. .	4,132,083	1/1979	McGrath .
2,740,427	4/1956	Swan .	4,149,568	4/1979	Kuntz .
2,766,614	10/1956	Cook .	4,157,101	6/1979	Ross .
2,800,145	7/1957	Peierls et al. .	4,157,104	6/1979	Lofquist, Jr. .
2,913,011	11/1959	Noyes et al. .	4,157,194	6/1979	Takahashi .
2,952,390	9/1960	Fowler et al. .	4,172,474	10/1979	Stahle .
2,956,586	10/1960	Zeigler et al. .	4,172,607	10/1979	Norton .
3,011,829	12/1961	Wiseman .	4,182,581	1/1980	Uehara et al. .
3,016,928	1/1962	Brandt .	4,232,736	11/1980	Pillette .
3,047,026	7/1962	Kahn .	4,250,927	2/1981	Newburg .
3,073,351	1/1963	Nichols .	4,274,549	6/1981	Germain .
3,117,596	1/1964	Kahn .	4,309,128	1/1982	Williams .
3,183,723	5/1965	Peters .	4,310,033	1/1982	Deters .
3,221,758	12/1965	Morse .	4,318,835	3/1982	Clarke .
3,245,701	4/1966	Leopold, Jr. et al. .	4,330,017	5/1982	Satoh et al. .
3,254,678	* 6/1966	Plummer 138/151 X	4,333,451	6/1982	Paluch .
3,367,370	2/1968	Sherlock .	4,415,389	11/1983	Medford et al. .
3,459,229	8/1969	Croft .	4,431,031	2/1984	Ettlinger .
3,464,450	9/1969	Steffenini .	4,436,987	3/1984	Thalmann et al. .
3,490,496	1/1970	Stearns .	4,449,853	5/1984	Mennella et al. .
3,531,264	9/1970	Greipel .	4,492,089	1/1985	Rohner et al. .
3,531,265	9/1970	Greipel .	4,510,974	4/1985	Natori et al. .
3,543,377	12/1970	Bremner .	4,521,037	6/1985	Knox .
3,559,408	2/1971	Earnhart .	4,561,292	12/1985	Pugnale et al. .
3,561,493	2/1971	Maillard et al. .	4,565,351	1/1986	Conti et al. .
3,580,289	5/1971	James et al. .	4,566,504	1/1986	Furrow et al. .
3,581,776	6/1971	Sheahan .	4,568,925	2/1986	Butts .
3,619,474	11/1971	Beck .	4,570,678	2/1986	Ziemek et al. .
3,672,103	6/1972	Kost .	4,570,686	2/1986	Devine .
3,672,180	6/1972	Davis .	4,573,829	3/1986	Keene et al. .
3,688,801	9/1972	Rohrer .	4,612,744	9/1986	Shamash .
3,720,235	3/1973	Schrock .	4,615,362	10/1986	Hartman et al. .
3,721,270	3/1973	Wittgenstein .	4,618,168	10/1986	Thalmann et al. .
3,732,902	5/1973	Muller .	4,620,569	11/1986	von Glanstätten et al. .
3,753,287	8/1973	Ziemek et al. .	4,629,216	12/1986	Pedersen .
3,756,291	9/1973	McGaney et al. .	4,639,164	1/1987	Pugnale et al. .
3,766,949	10/1973	Champleboux et al. .	4,643,460	2/1987	Lieberg .
3,791,422	2/1974	Johnson et al. .	4,644,780	2/1987	Jeter .
3,799,440	3/1974	Goss et al. .	4,659,251	4/1987	Petter et al. .
3,802,456	4/1974	Wittgenstein .	4,662,655	5/1987	Fliervoet et al. .
3,814,148	6/1974	Wosh .	4,667,505	5/1987	Sharp .
3,837,364	9/1974	Jenner .	4,678,370	7/1987	Allen .
3,841,671	10/1974	Walker .	4,682,911	7/1987	Moreland .
3,863,687	2/1975	Alguist .	4,685,831	8/1987	Mahoney .
3,871,408	3/1975	Wood et al. .	4,700,751	10/1987	Federick .
3,905,398	9/1975	Johansen et al. .	4,702,645	10/1987	Skinner et al. .
3,907,010	9/1975	Burtis et al. .	4,706,712	11/1987	Oglesby et al. .
3,926,230	12/1975	Stary et al. .	4,718,568	1/1988	Dal Palu .
3,929,957	12/1975	Holden et al. .	4,739,648	4/1988	Horner .
3,974,862	8/1976	Fuhrmann .	4,756,339	7/1988	Buluschek .
3,982,776	9/1976	Payne .	4,758,455	7/1988	Campbell et al. .
3,995,472	12/1976	Murray .	4,767,237	8/1988	Cosman et al. .
4,009,739	3/1977	Weatherford .	4,770,562	9/1988	Müller et al. .
4,009,985	3/1977	Hirt .	4,778,310	10/1988	Moreland .
4,010,581	3/1977	Keturi et al. .	4,779,652	10/1988	Sweeney .
4,010,779	3/1977	Pollock et al. .	4,786,088	11/1988	Ziu .
4,014,369	3/1977	Kobres, Jr. .	4,787,772	11/1988	Wagner .
			4,796,669	1/1989	St. Onge .

US RE37,114 E

Page 3

4,796,676	1/1989	Hendershot et al. .	5,098,221	3/1992	Osborne .
4,802,938	2/1989	Kitami et al. .	5,101,918	4/1992	Smet .
4,805,444	2/1989	Webb .	5,102,012	4/1992	Foster .
4,842,027	6/1989	Faeth .	5,109,600	5/1992	Holden et al. .
4,865,359	9/1989	Roberts .	5,129,428	7/1992	Winter et al. .
4,870,856	10/1989	Sharp .	5,129,686	7/1992	Sanders et al. .
4,874,268	10/1989	Akesaka .	5,135,324	8/1992	Bravo .
4,881,576	11/1989	Kitami .	5,141,260	8/1992	Burwell .
4,886,304	12/1989	Kunzman .	5,145,545	9/1992	Winter et al. .
4,886,305	12/1989	Martin .	5,148,836	9/1992	Lawrence .
4,887,647	12/1989	Igarashi et al. .	5,152,635	10/1992	Ziu .
4,896,705	1/1990	Podgers et al. .	5,156,191	10/1992	Walker et al. .
4,903,719	2/1990	Rains .	5,156,699	10/1992	Nakano et al. .
4,906,496	3/1990	Hosono et al. .	5,186,357	2/1993	Foster .
4,926,899	5/1990	Argandona .	5,186,502	2/1993	Martin .
4,930,544	6/1990	Ziu .	5,199,752	4/1993	Sanders et al. .
4,932,257	6/1990	Webb .	5,256,233	10/1993	Winter et al. .
4,951,720	8/1990	Grantham .	5,257,652	11/1993	Lawrence .
4,958,957	9/1990	Berg et al. .	5,259,418	11/1993	Hamrick .
4,967,809	11/1990	Faeth .	5,263,794	11/1993	Webb .
4,968,179	11/1990	Frahm .	5,267,670	12/1993	Foster .
4,971,477	11/1990	Webb et al. .	5,279,332	1/1994	Winter et al. .
4,984,604	1/1991	Nishimura .	5,279,333	1/1994	Lawrence .
4,991,626	2/1991	Grantham .	5,281,757	1/1994	Martin et al. .
5,005,613	4/1991	Stanley .	5,282,744	2/1994	Grantham et al. .
5,018,260	5/1991	Ziu .	5,285,826	2/1994	Sanders et al. .
5,022,459	6/1991	Chiles et al. .	5,297,896	3/1994	Webb .
5,030,033	7/1991	Heintzelman et al. .	5,305,798	4/1994	Driver .
5,037,143	8/1991	Sanders et al. .	5,343,738	9/1994	Skaggs .
5,038,833	8/1991	Brunnhofer .	5,383,087	1/1995	Noone et al. .
5,040,408	8/1991	Webb .	5,433,252	7/1995	Wolf et al. .
5,040,577	8/1991	Pope .	5,488,975	2/1996	Chiles et al. .
5,042,537	8/1991	Grantham .	5,490,419	2/1996	Webb .
5,051,034	9/1991	Goodman .	5,527,130	6/1996	Webb .
5,052,444	10/1991	Messerly et al. .	5,553,971	9/1996	Osborne .
5,056,569	10/1991	Walker et al. .	5,567,083	10/1996	Osborne .
5,060,509	10/1991	Webb .	5,590,981	1/1997	Osborne .
5,076,329	12/1991	Brunnhofer .			
5,089,074	2/1992	Winter et al. .			
5,093,166	3/1992	Nishimura .			

* cited by examiner

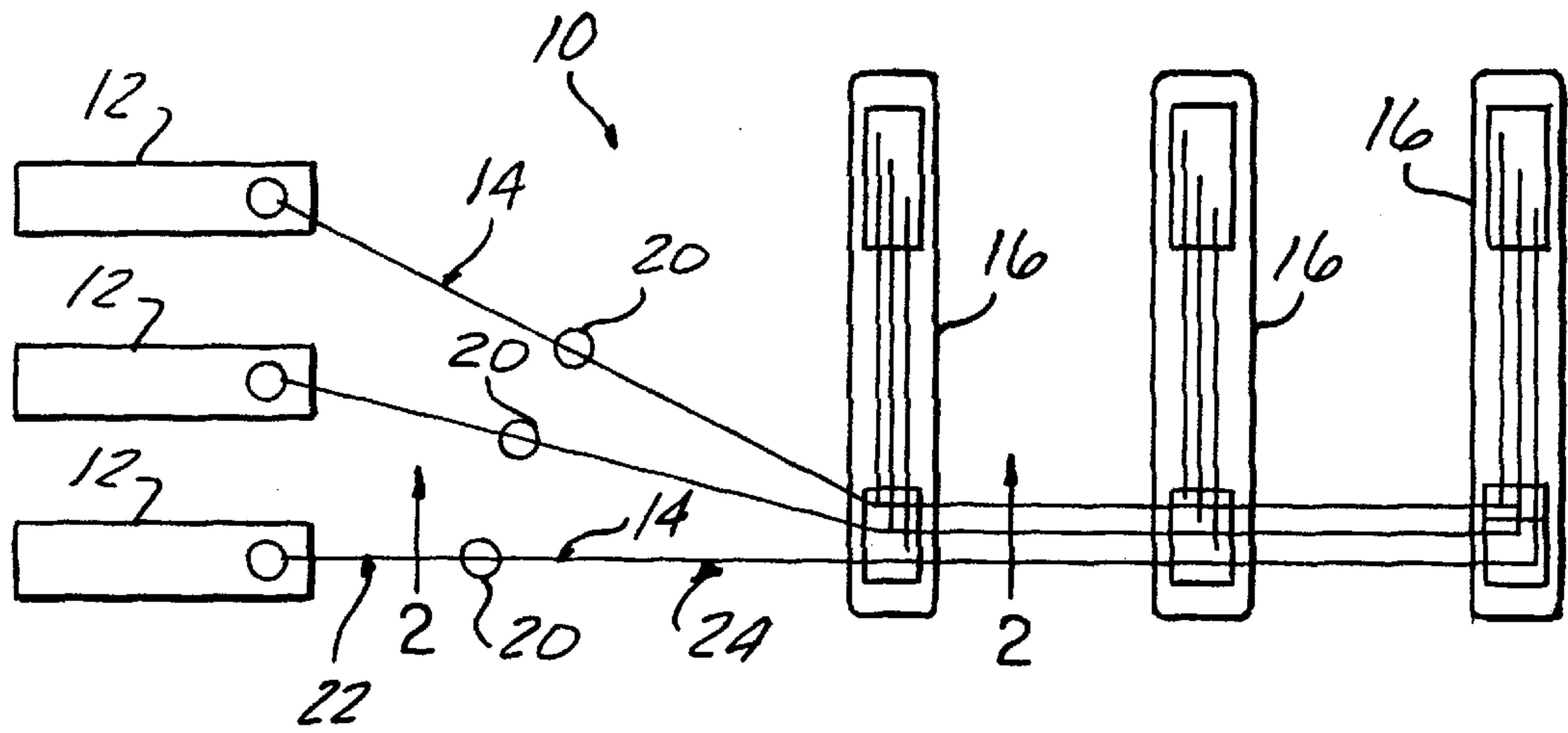

FIG-1

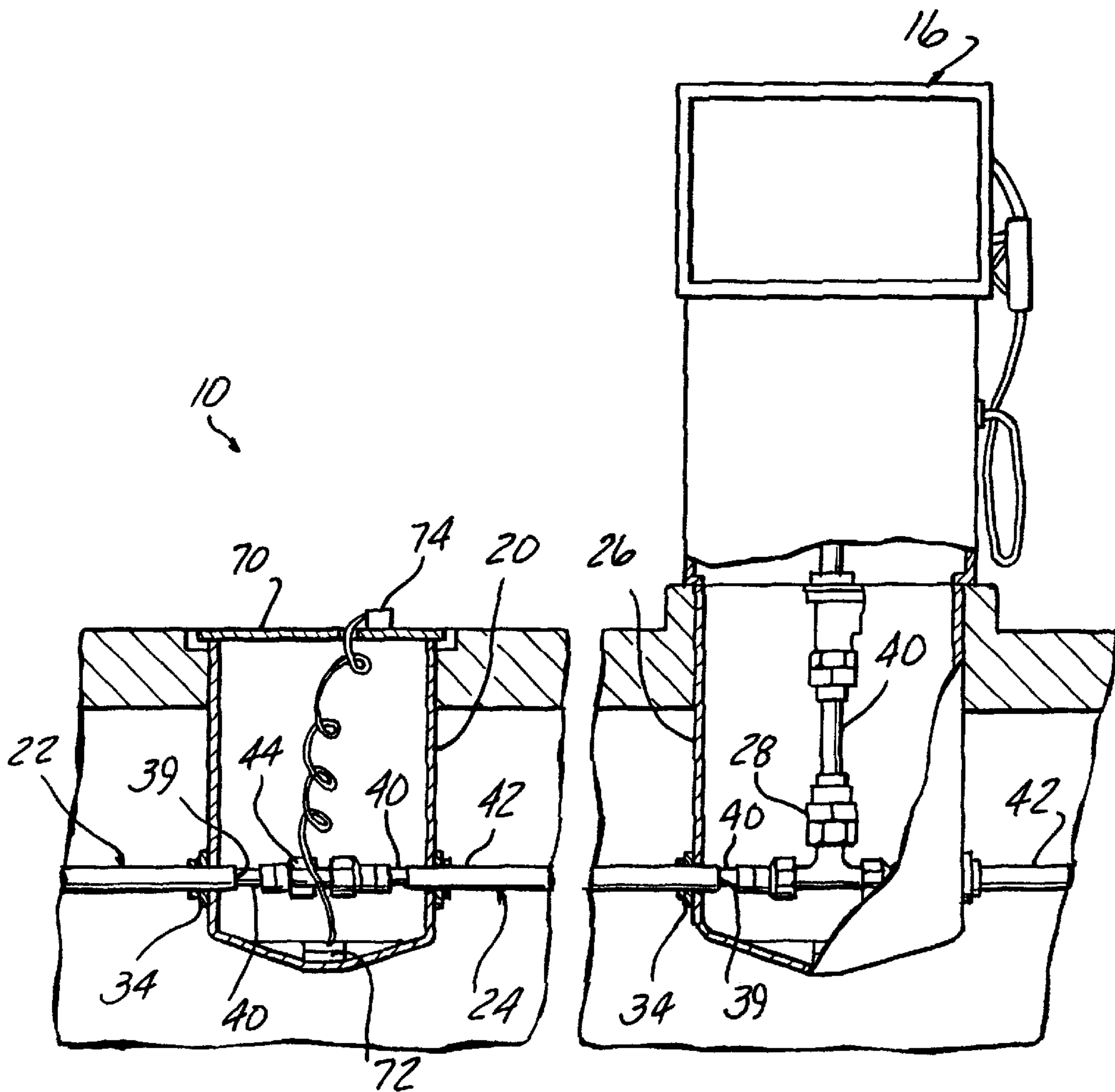

FIG-2

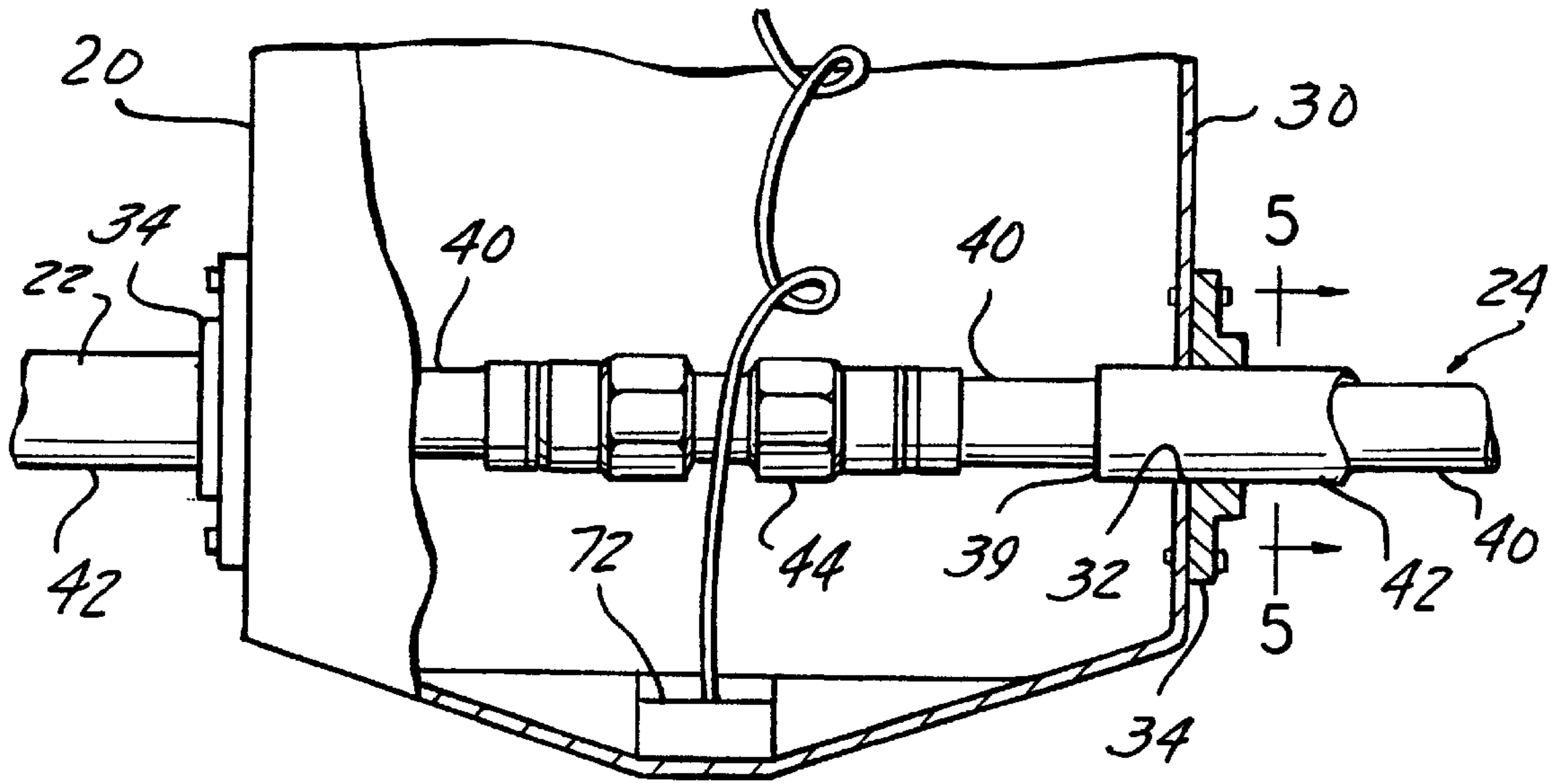

FIG - 3

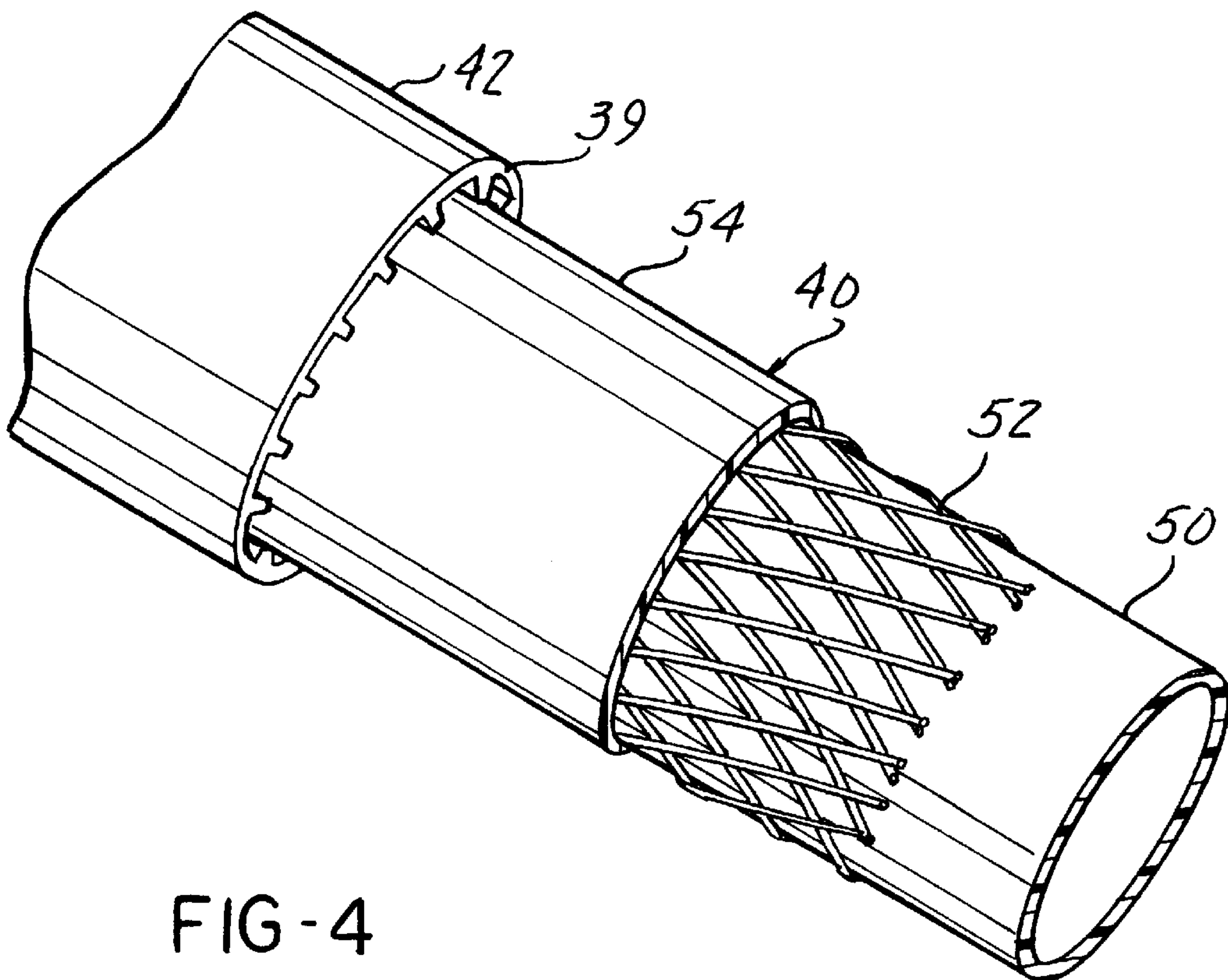

FIG - 4

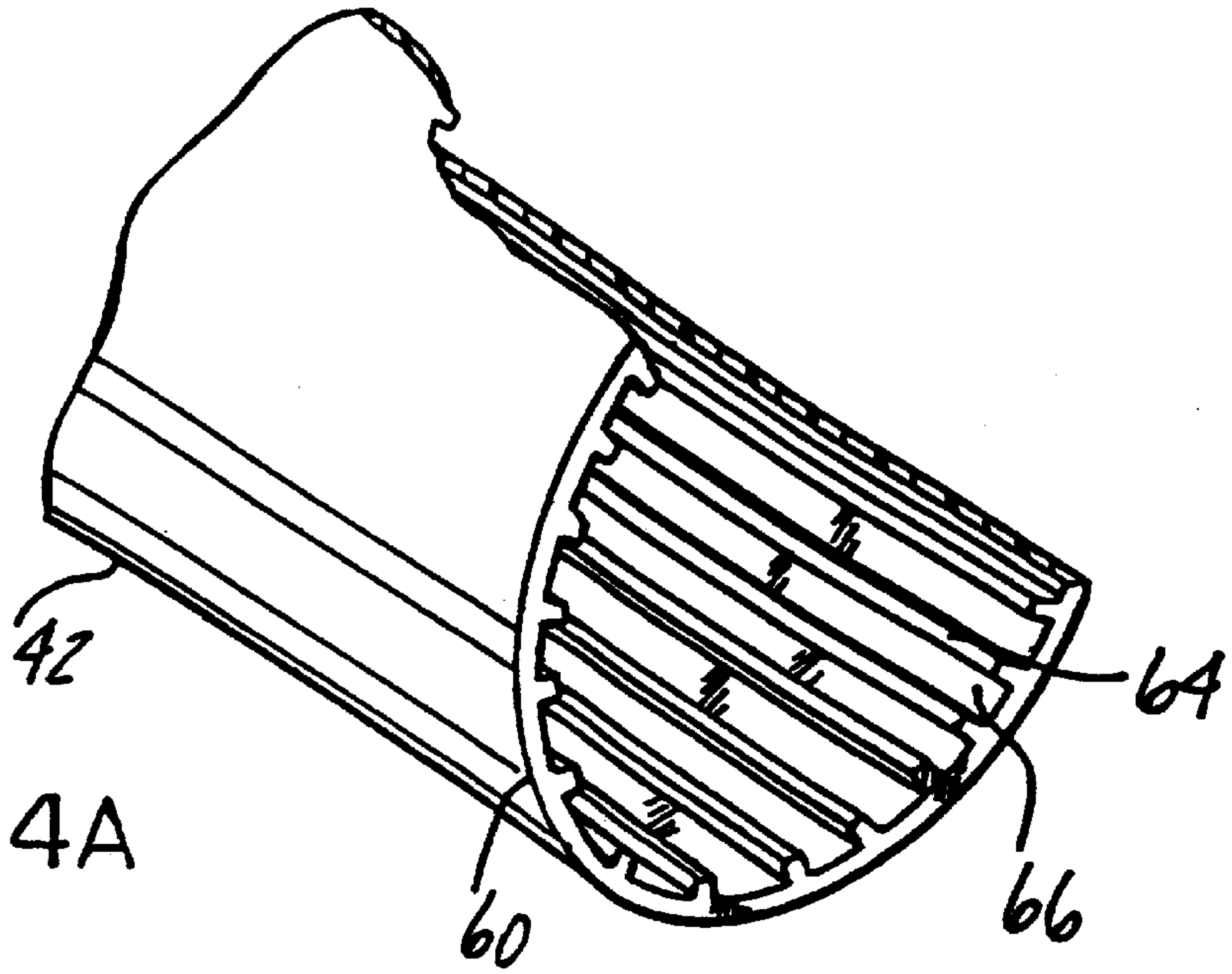

FIG-4A

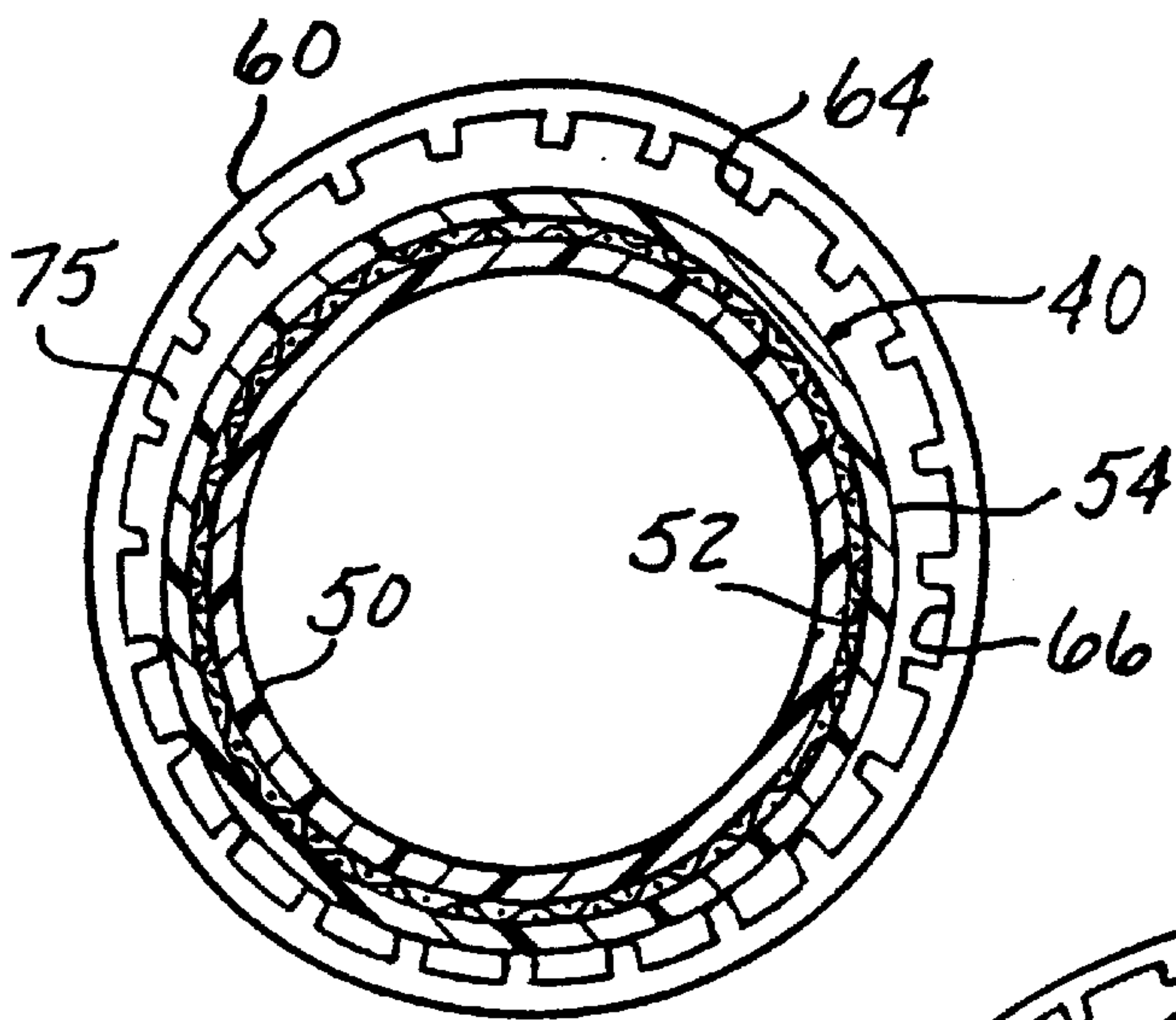

FIG-5
(AMENDED)

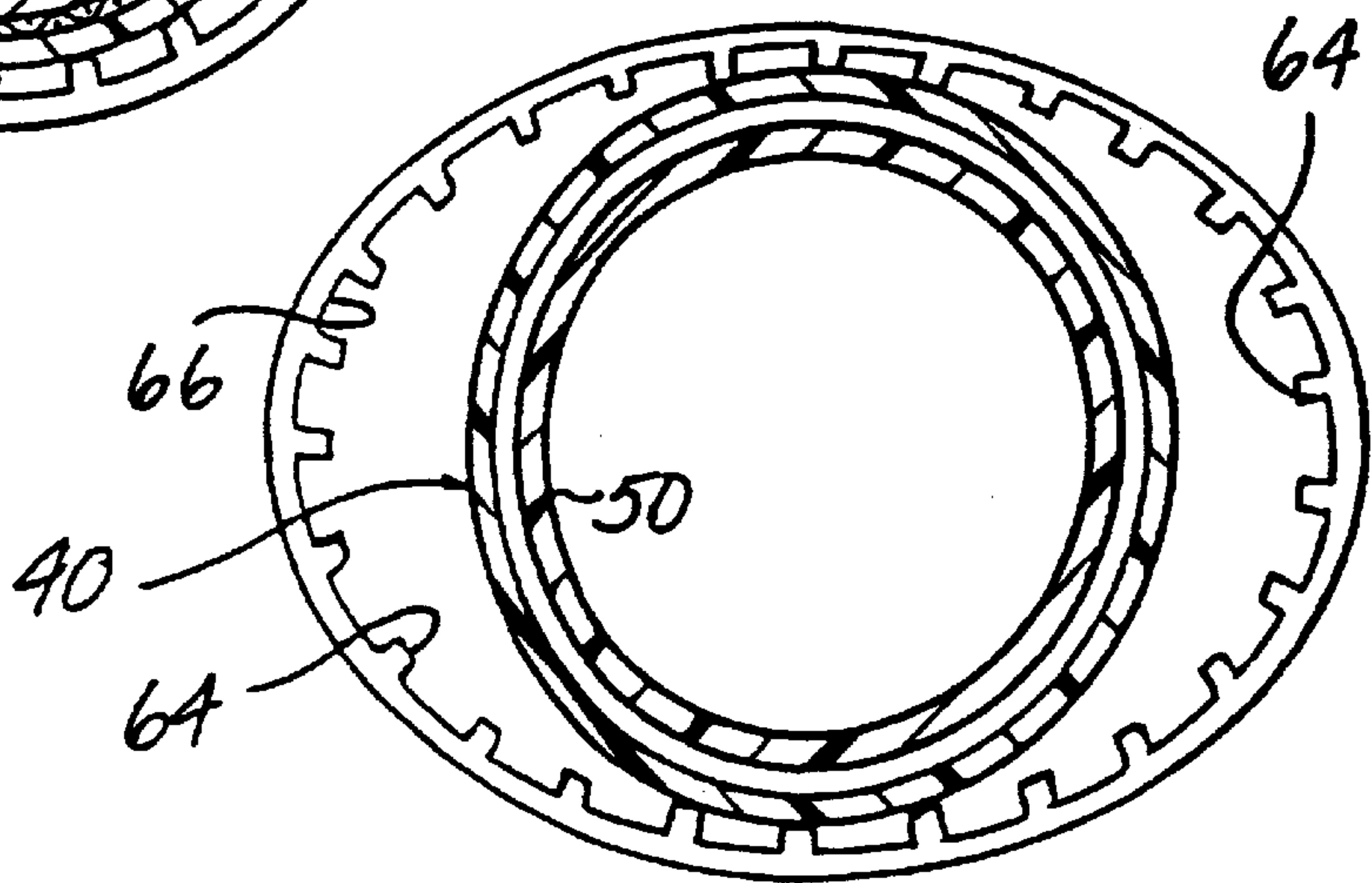

FIG-6
(AMENDED)

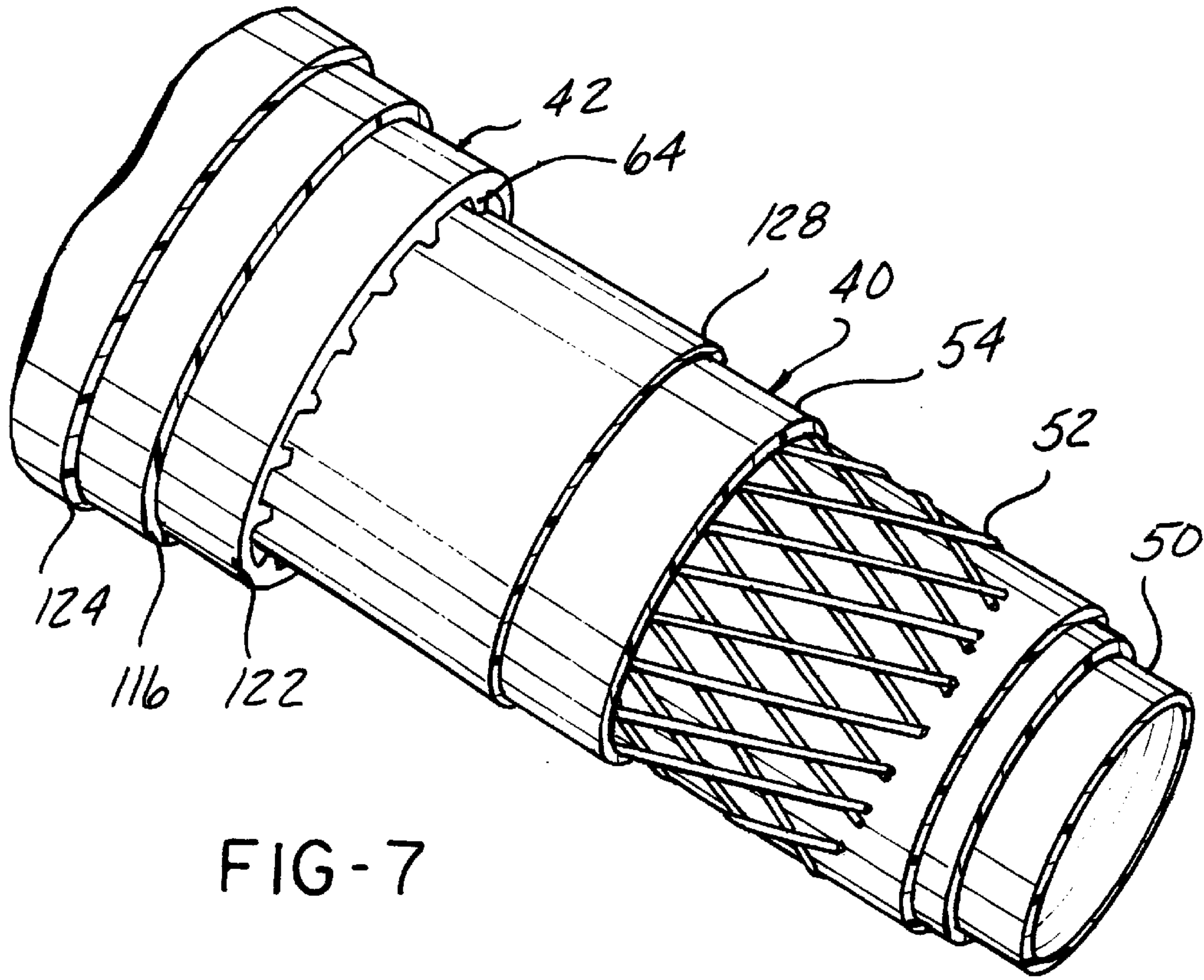

FIG-7

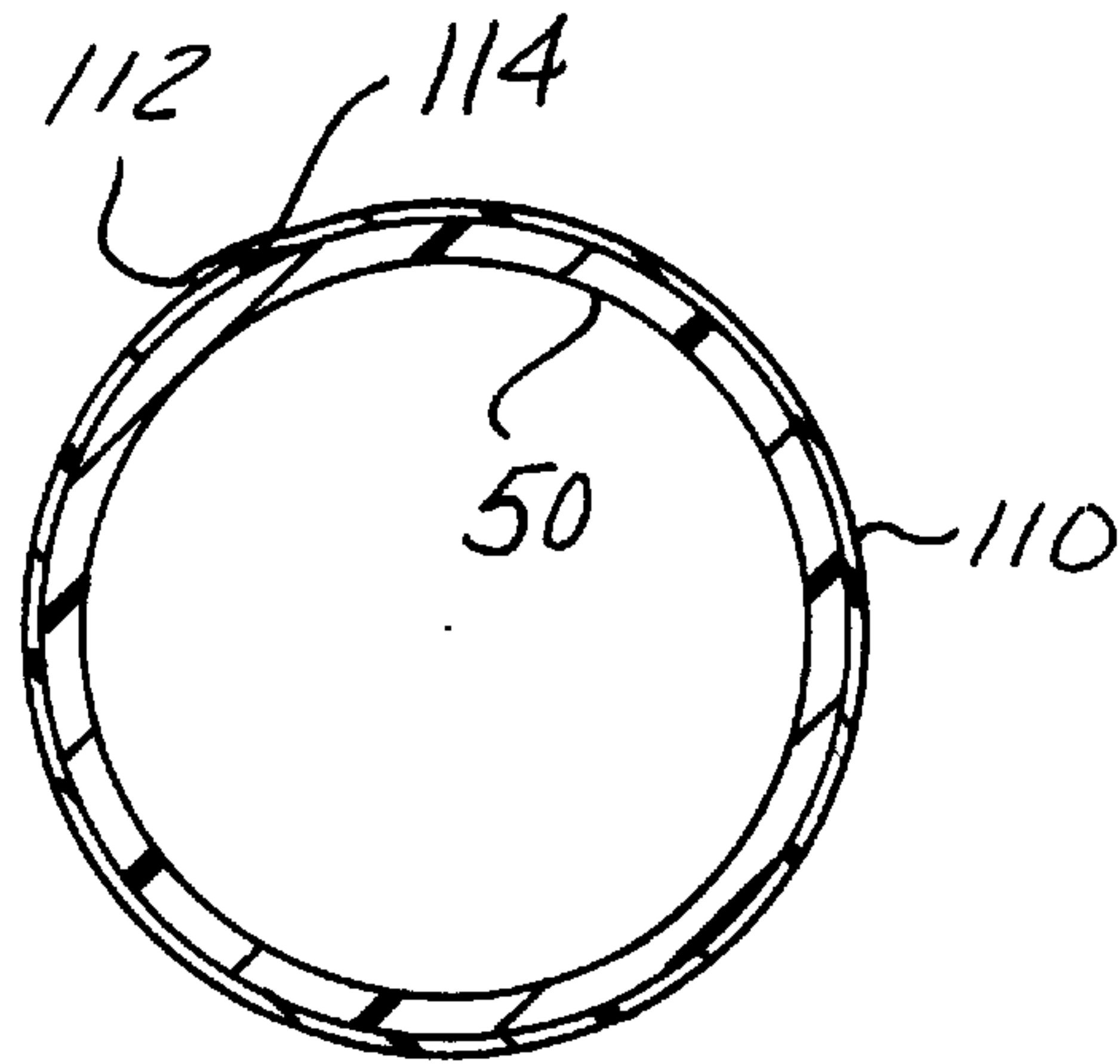

FIG-8

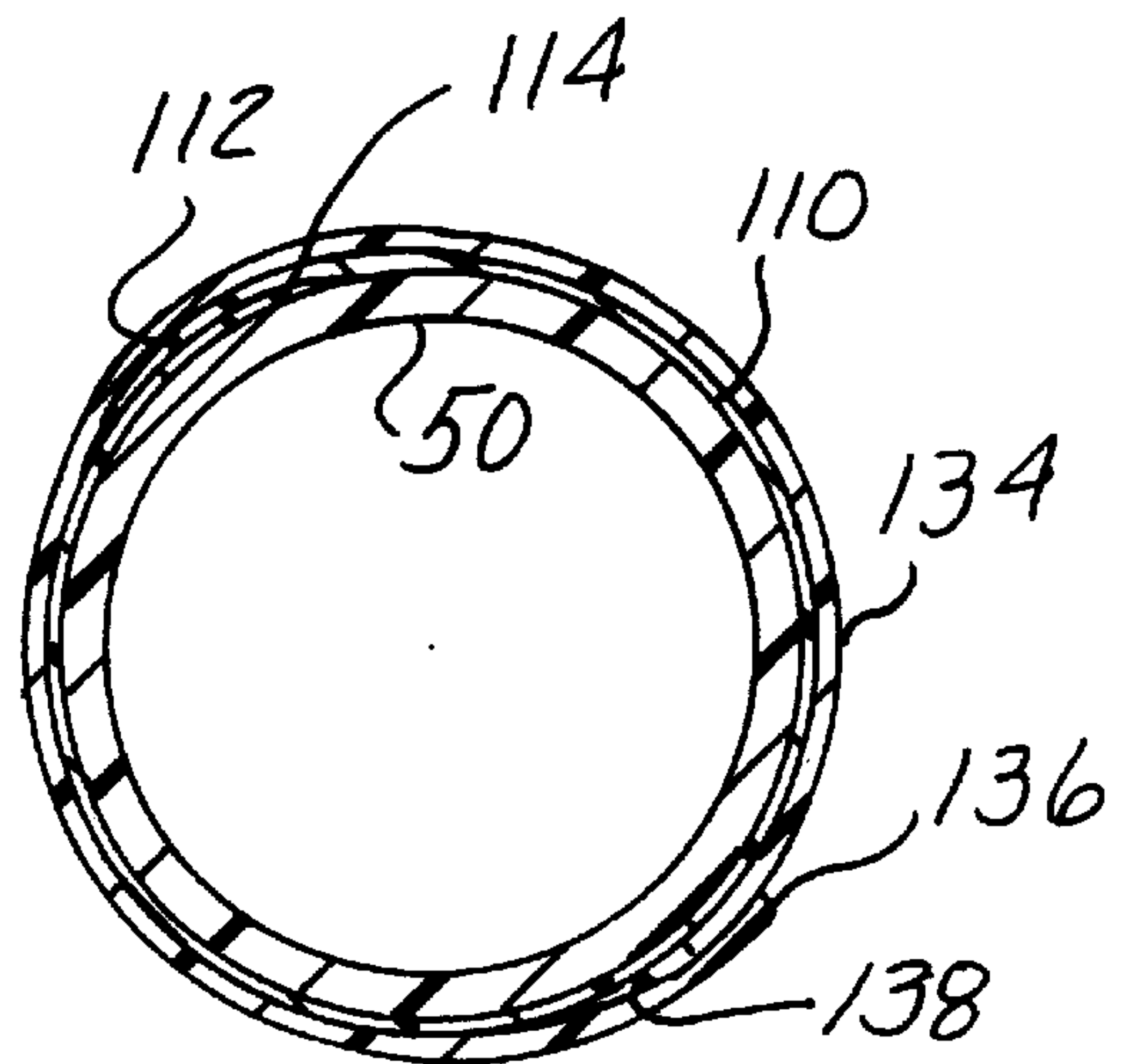

FIG-9

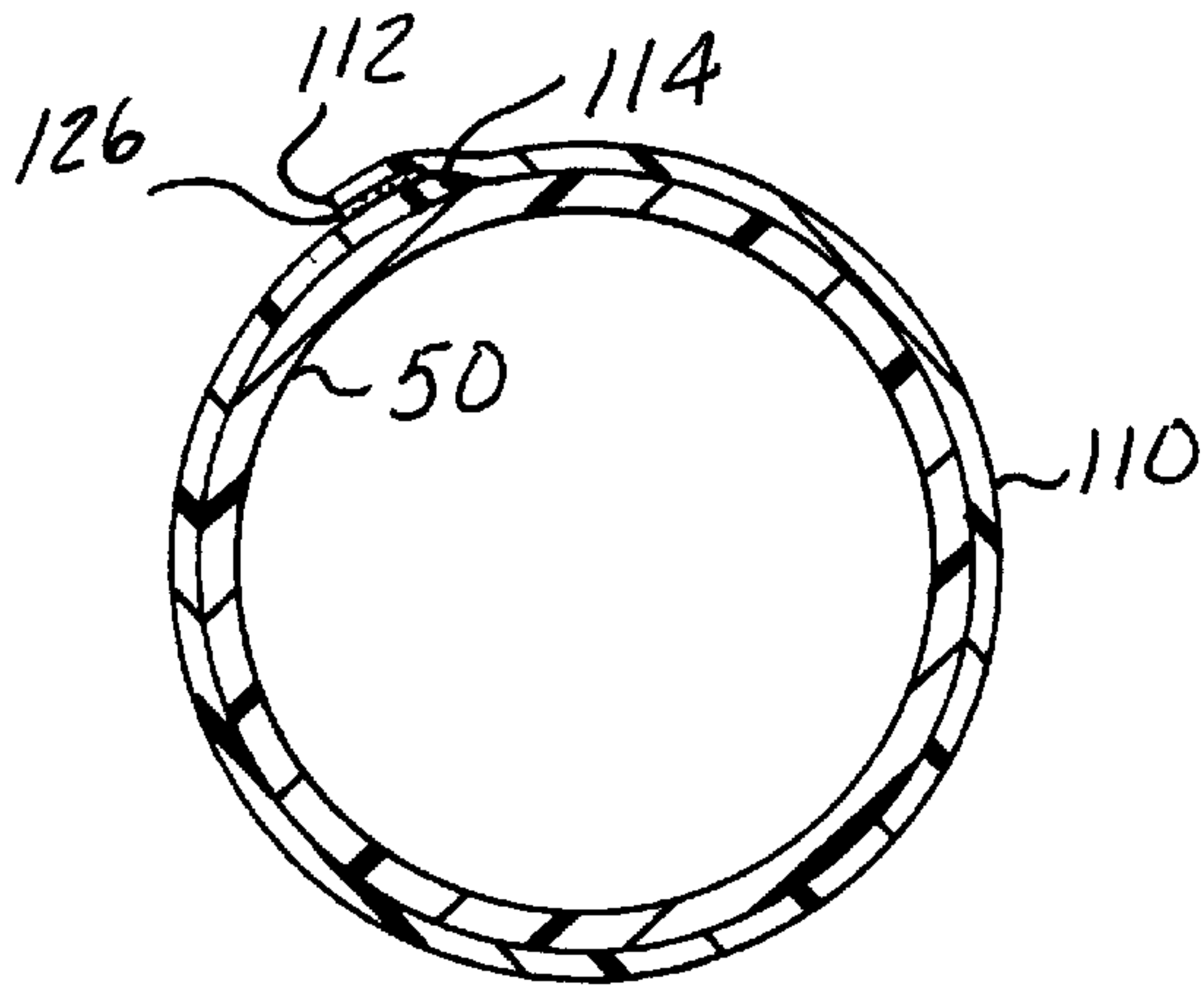

FIG-10

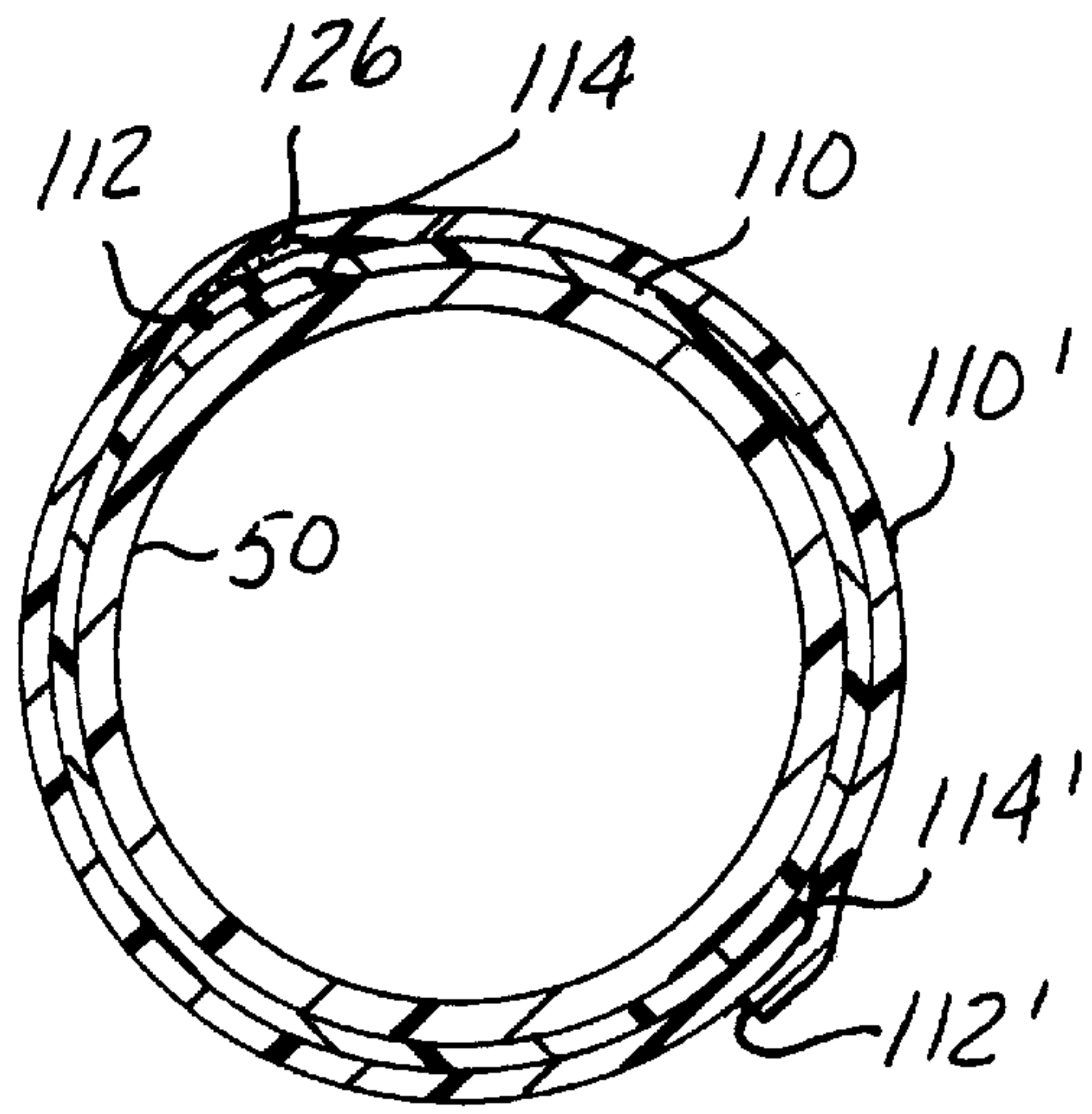

FIG-11

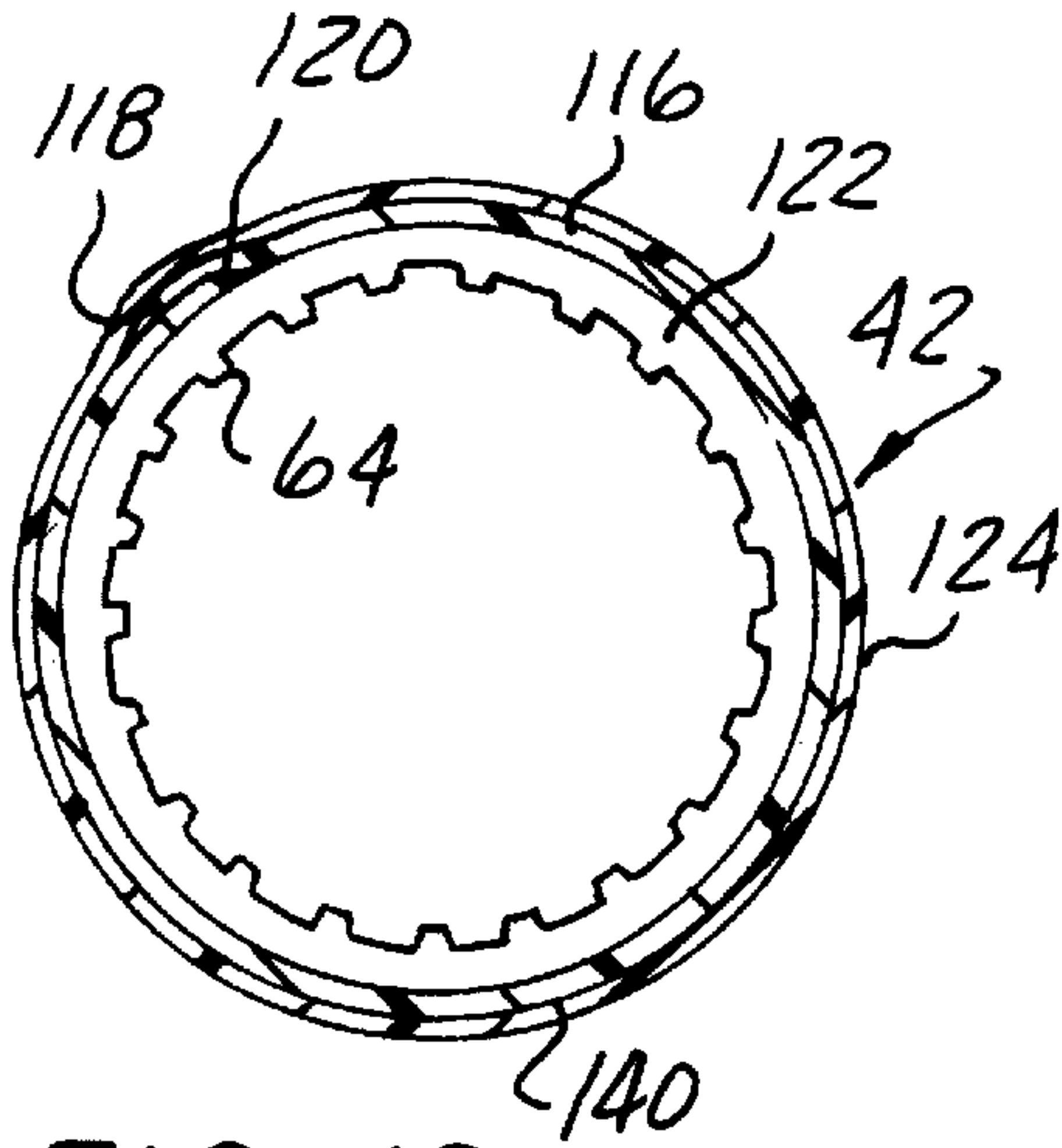

FIG-12

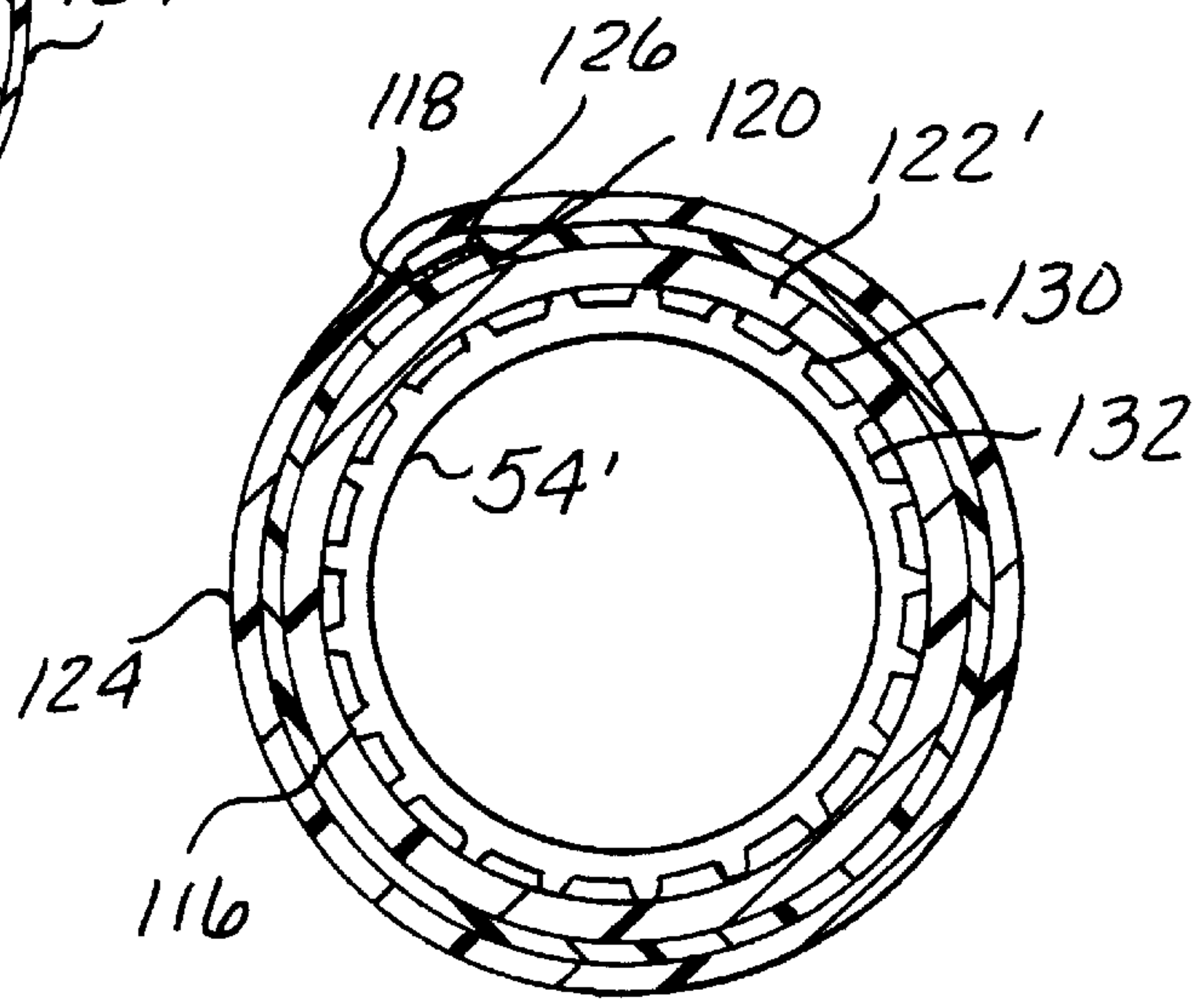

FIG-13

SECONDARY CONTAINMENT FLEXIBLE UNDERGROUND PIPING SYSTEM

Matter enclosed in heavy brackets [] appears in the original patent but forms no part of this reissue specification; matter printed in italics indicates the additions made by reissue.

[CROSS-REFERENCE TO RELATED APPLICATIONS

This application is a continuation-in-part of pending U.S. patent application Ser. No. 07/859,034, filed Mar. 27, 1992.]

BACKGROUND OF THE INVENTION

The present invention relates to secondary containment systems and especially, although not exclusively to a piping construction and a method for providing secondary containment systems for hydrocarbon storage and delivery systems.

A secondary containment system is one which functions to collect and contain the fluids leaking out of another and primary containment system. For example, a primary containment system may store and deliver gasoline at a filling station. A secondary containment system would collect and contain the same gasoline if a primary delivery pipe should rupture or otherwise spill the gasoline. Secondary containment systems have been developed to overcome the environmental problems that have been encountered with respect to leakage of hazardous fluids from tanks and pipe lines. As indicated, this has been a particular problem with respect to underground installations in which undetected leakage of hazardous fluids into the surrounding terrain over long periods of time has produced harmful conditions and extensive pollution which are difficult and expensive to clean.

Today there is great public concern because chemicals are penetrating into underground water supplies contaminating public drinking water and making some of the food supply unusable, among other things. The entire environment is being degraded to a serious level which tends to cast doubt on the future availability of safe water. Therefore, many government agencies have enacted and continue to enact laws which require a secondary containment system designed to capture and contain the spilled gasoline or other liquid materials thus preventing it from leaking into the surrounding earth. The capture gasoline or other liquid material may then be pumped out of the secondary container for proper disposal. The eliminates the possibility of gasoline spillage to contaminate underground water supply.

Manufacturers of containment systems have responded by developing and producing a variety of secondary containment systems for conventional underground piping which are designed to contain and prevent any leakage from escaping into the environment. Many of these systems have proven to be effective containment systems but have been found to be difficult and costly to install.

One known approach to secondary containment systems, and, in particular, the secondary containment of underground conventional piping has been to line the piping trench with an impervious flexible membrane liner or semi-rigid trough. This technique can provide a measure of secondary containment of leaky product but such an approach does not allow for effective leaking detection in that it does not permit the determination of which pipe is leaking and the location of the leak in the piping line when the same occurs. It is also difficult to test such systems using air pressure testing devices. Additionally, these secondary containment systems do not provide 360° containment, and therefore can fill with water and become ineffective.

Another approach toward solving the problem of underground leakage in such conventional piping systems has been to install a large semi-conventional piping system over the conventional underground piping as a means for providing the secondary containment. With such an arrangement, the outer secondary containment rigid pipe is installed simultaneously with the product piping. The outer secondary containment pipe by necessity has a larger diameter than the supply pipe to enable secondary containment pipe to slide over the smaller pipe. The secondary containment pipe fittings are of a clam shell design adapted to fit over the supply pipe fitting and connect to the secondary containment pipe. The clam shell fitting is sealed to itself and the secondary containment pipe by a variety of sealing techniques. Depending on the type of secondary containment system used, these sealing techniques could include metal or plastic fasteners used with a combination of adhesives, sealants and the like. Such secondary systems are generally expensive to install because of the cost of the components which are used and the time required to assemble both the product and the secondary containment piping systems.

Another known approach to solving the aforementioned problems is to employ a semi-conventional piping system over the conventional product piping. This type of containment system differs from the first described system in that it is not an entirely rigid straight pipe but rather a combination of rigid straight pipe with a larger diameter, convoluted plastic pipe over it which produces a telescoping effect. The convoluted section of telescopic containment pipe serves as a fitting of containment of the product, 90° and 45° fittings as well as unions, flexible connectors, swing joints, should they be so attached. The convoluted pipe is designed to be flexible and sized to be shifted around any angles in the production piping system.

Another type of secondary containment piping system has been developed which utilizes spaced access chambers interconnected by a secondary containment pipe to provide a sealed housing for a flexible fluid supply pipe, the ends of which are disposed within the access chambers and have a connector element at each end forming a section adapted to be interconnected to other fluid conduits. The diameter and bending radius of the fluid supply pipe and the size of the access chamber are such as to permit the fluid pipe, after uncoupling, to readily be removed from the secondary containment pipe through one of the access chambers. Should a leak occur in the piping, the secondary containment system allows the piping to be removed and replaced.

It is very difficult and expensive to meet all of the many different environmental and safety standards at a reasonably acceptable cost, particularly in light of the many state and local governments writing individual laws that impose a wide variety of standards which the manufacturers of such systems must meet.

Accordingly, an object of the invention is to provide a new and improved secondary containment system which will draw all spilled fluids that may leak from a primary supply pipe to a preselected collecting point which may be monitored.

Another object of the present invention is to provide a practical secondary containment system which may be manufactured in a factory, shipped and installed at a reasonably low cost in a fully usable manner and yet one which meets all requirements of the environment within which they must be used.

It is a further object of the present invention to provide an economical, easily installed, highly durable and environ-

mentally secure flexible piping system. It is a further object of the present invention to provide such a flexible piping system which may optionally eliminate coextrusion.

SUMMARY OF THE INVENTION

The present invention addresses and solves the problems enumerated above. The present invention comprises a secondary containment piping system, comprising an inner supply pipe. The piping system further comprises a flexible, fuel impervious outer secondary containment pipe, within which the inner supply pipe is carried. One of an outer surface of the inner supply pipe and an inner surface of the outer pipe has a plurality of radially outwardly projecting flanges adapted to engage the other of the outer surface of the inner supply pipe and the inner surface of the outer pipe when the pipes are buried. This provides a locking engagement of the pipes with respect to each other, and provides for a flow passage between the pipes. The inner pipe is comprised of a first, inner layer being fabricated from nylon; a second layer comprising a wrap having two opposed longitudinal edges in overlying relationship, the wrap being fabricated from a polyester film; a third layer comprising a nylon reinforced braid; and a fourth, outer layer comprising a polyethylene material. The outer pipe is comprised of a first, inner layer comprised of one of a polyethylene or an ethylene vinyl acetate material, the first layer having a plurality of radially inwardly projecting flanges; a second layer comprising a wrap having two opposed longitudinal edges, the wrap being fabricated from a metallized polyester film; and a third, outer layer comprising a polyethylene material.

BRIEF DESCRIPTION OF THE DRAWINGS

Other objects, advantages and applications of the present invention will become apparent to those skilled in the art of underground piping systems when one example of the best mode of the present invention is read in conjunction with the accompanying drawings, in which:

FIG. 1 is a schematic layout of an exemplary gasoline storage and delivery system;

FIG. 2 is an enlarged side view of a portion of the fuel dispensing system of FIG. 1 as seen generally along line 2—2 thereof;

FIG. 3 is an enlarged view of a portion of the system illustrated in FIG. 2;

FIG. 4 is an enlarged perspective view of the inner and outer pipes utilized in the secondary containment piping system of the present invention with layers of the inner pipe removed for illustrative purposes;

FIG. 4A is a fragmentary perspective view of the outer secondary containment pipe illustrated in FIG. 4;

FIG. 5 is a cross sectional view taken generally along line 5—5 proper to the backfilling of the trench within which the pipes are located;

FIG. 6 is a view similar to FIG. 5 illustrating, in a slightly exaggerated manner, the secondary containment piping system after backfilling;

FIG. 7 is an enlarged perspective view of the inner and outer pipes utilized in the secondary containment piping system of the present invention with layers of the inner and outer pipes removed for illustrative purposes;

FIG. 8 is a cross sectional view of the first layer of the inner supply pipe showing, in an exaggerated manner, a single polyester film wrap thereover;

FIG. 9 is a cross sectional view of the first layer of the inner supply pipe showing, in an exaggerated manner, a

double polyester film wrap thereover, with the wrap seams rotated 180° from each other;

FIG. 10 is a cross sectional view of the first layer of the inner supply pipe having a single polyester film wrap thereover and showing, in an exaggerated manner, the wrap edges overlapping with a heat seal adhesive therebetween;

FIG. 11 is a view similar to FIG. 10, with an additional polyester film wrap over the first wrap;

FIG. 12 is the outer pipe showing, in an exaggerated manner, a single polyester film wrap thereover and a polyethylene covering layer; and

FIG. 13 shows the outer surface of the inner supply pipe having outward projections, the outer pipe having a smooth inner surface, and showing, in an exaggerated manner, a single polyester film wrap thereover with a heat seal adhesive between the overlapping wrap edges and a polyethylene covering layer.

DESCRIPTION OF THE PREFERRED EMBODIMENTS

Referring now to the drawings, and, in particular, to FIGS. 1 and 2, wherein there is illustrated an underground fuel storage and dispensing system generally indicated at 10 comprising fuel tanks 12 from which a plurality of underground fuel supply pipes 14 extend for distribution of fuel to dispersion areas 16 in a conventional manner. The system includes one or more access chambers 20 which are also disposed below the surface dispensing station 16. The access chambers 20 and the fuel tanks 12 are interconnected by containment pipe segments 22 while the access chambers are connected via pipe segments 24 to a conventional drip pan 26 beneath the dispenser 16 and is connected thereto through suitable elbow connectors 28. The access chamber 20 and the pan 26 are interconnected in a fluid sealing manner through their side walls just above the bases thereof by means of the secondary containment pipe 24.

As can best be seen in FIG. 3, the side wall 30 of the access chamber 20 has an opening 32 through which the end of the pipe 24 extends. A conventional seal 34 surrounds the outer surface of the containment pipe 24 and provides a fluid tight seal for the inner of the access chamber 20.

As will be described in greater detail hereinafter, the secondary containment piping system comprises a flexible inner supply pipe 40 which is completely encased within a flexible outer containment pipe 42. It should be noted by reference to FIG. 3, that the outer containment pipe 42 extends into the access chamber 20 a sufficient distance so that it clears the interior of the wall 30 of the access chamber 20. During fabrication this will permit the insertion on the terminated end 39 of pipe 42 of a suitable air pressure device to permit testing as will be explained hereinafter. The inner pipe 40 extends past the terminated end 39 of the outer pipe 42 a sufficient distance to permit it to be coupled by suitable conventional couplings 44 to another inner pipe 40 which, in turn extends outwardly from the access chamber 20 through an outer containment pipe 42. At the drip pan 26, the pipe 40 exits therethrough and continues through a containment pipe 42 on to the next island.

The access chamber 20 has a removable cover 70 to permit easy access thereto for removal of any fuel that might be captured by the containment pipe 40. A fluid sensor 72 is disposed in the bottom of the access chamber 22 and is electrically connected to an appropriate indicator or alarm 74. When there is an accumulation of fluid, such as due to leakage from the primary pipe 40, the fluid will actuate the alarm.

As can best be seen in FIGS. 4 and 5, the inner pipe 40 is made from a fuel impervious material and is comprised of three layers of material which are extruded together and comprise an interior layer 50, which is fabricated from a nylon 12 material; an intermediate layer 52 consisting of a nylon 6 yarn reinforcement wrap; and an exterior outer material 54 which is preferably fabricated from a polyethylene material. The inner layer 50 is 0.080" thick and the outer layer is preferably 0.060" thick. In the preferred embodiment, the pipe 40 has an inside diameter of 1.68" and an outside diameter of 1.960", a maximum operating pressure of 150 psi and a minimum burst pressure of 750 psi. The material is flexible and has a bend radius of 12" to 24".

The inner pipe 40 is completely encased in the outer containment pipe 42 which, as can best be seen in FIGS. 4, 4A and 5, comprises an integrally extruded member having a wall 60, the interior of which is provided with a plurality of angularly spaced, radially inwardly extending ribs or projections 64 that define thereinbetween U-shaped cross sections [60]66. Outer pipe 42 may be extruded separately from inner pipe 40, or may be coextruded therewith. The projections extend along the full length of the interior of the wall 60 (FIG. 4A). The outer pipe 42 is sized to permit the inner pipe 40 to be inserted therein with little or no resistance and is, preferably, assembled in the combined arrangement at the factory, ready for positioning in the pipe trenches when delivered onsite. The outer pipe 42 is very flexible and can bend as needed to accommodate the bending of the primary inner pipe 40. The outer pipe 42 is made from a fuel impervious material such as a nylon or polyethylene, clear acrylonitrile or clear polyurethane material.

In another preferred embodiment, in order to achieve greater permeation resistance, outer pipe 42 may optionally be formed from a plasticized nylon 11, or a polyester elastomer used as a thermoplastic rubber. One such polyester elastomer is commercially available from E. I. du Pont de Nemours Co. under the tradename HYTREL. Outer pipe 42 may further be optionally formed from a coextrusion of low density polyethylene or SURLYN ionomer as an inner layer, and nylon 11 as an outer layer.

In practice, trenches are laid out and the various lengths of piping are laid in the trenches and connected to the various underground access chambers 20 and drip pans 26 via the sealing members 34. Once connected, a portion of the outer pipe 42 is cut and removed so that a sufficient amount of the inner pipe 40 extends past the termination end 39 of the outer pipe 42 to permit the inner pipe 40 to be attached to a suitable coupling 44.

Before a coupling 44 is attached to the inner pipe 40, an appropriate seal may be placed over the outside of the inner pipe 40 to sealingly engage the outer pipe 42 whereby pressurized air may be communicated to the annular space (FIG. 5) formed between the inner and outer pipes 40 and 42 to test the same to be sure that there are no leakage points in the containment system. Obviously, the opposite ends of the pipe 42 of each of the access chambers 22 and drip pans 26 must be sealed in order to effectively perform such a test. Likewise, the inner pipes 40 can be subjected to air pressure to test their integrity. Once the installer is satisfied that the containment piping system is able to perform its function without concern for leakage, the trenches within which the containment pipes 14 have been laid are backfilled.

The weight of the earth on the flexible outer pipe 42 deforms the pipe 42 in the manner similar to that illustrated in FIG. 6 of the drawings, until the outer ends of the projections 64 abut the outer wall of the inner pipe 40. The

abutment of the projections 64 with the wall 40 provides a two-fold purpose. First, it snugly and lockingly engages the pipe 40 and prevents relative movement between the inner and outer pipes providing for a more secure system. Secondly, the space between U-shaped cross sectional areas and the space between the inner and outer walls always insures a flow path for any fuel may leak into the annular space between the inner and outer pipes. The view illustrated in FIG. 6 is illustrative of the condition that may exist. However, it should be noted that the outer tube 42 may be deformed in a variety of different shapes. Suffice it to say that a continuous flow path will exist in the event there is a leakage from the primary inner pipe 40. While it is preferred that the primary pipe 40 and secondary containment pipe 42 be assembled at a factory location, there may be situations in which the pipes are assembled on site before burial. The pipe 40 may be removed and either pipe may be replaced if a leak is found during testing. Once buried, the weight of the fill collapses appropriate portions of the outer containment pipe 42 around the primary pipe 40 and the primary pipe 40 may no longer be removed after burial.

An alternate preferred embodiment comprises the use of one or multiple wrapped barrier films included in the structure of inner supply pipe 40 and/or outer secondary containment pipe 42. The addition of such barrier films allows for a greater degree of alcohol or hydrocarbon permeation resistance, thereby further enhancing the protection of the environment within which the secondary containment piping system is placed.

Referring now to FIG. 8, there is shown a preferred embodiment of use of a barrier film. The first, inner layer 50 of inner pipe 40 is fabricated from any suitable material, however, in the preferred embodiment, this is a plasticized nylon 12 material. It may be of any suitable diameter and the cross-sectioned wall may be of any suitable width. In the preferred embodiment, the width of first, inner layer is approximately 0.080 inches. A second layer 110 comprises a wrap having two opposed longitudinal edges 112, 114 in overlying relationship. The second layer 110, as with all the barrier films described herein, may be made from any suitable material having barrier properties. However, in the preferred embodiment, this second layer is fabricated from a polyester film having a very high tensile strength. One such polyester film is commercially available from E. I. du Pont de Nemours Company under the trade name MYLAR.

It is to be understood that the embodiment shown in FIG. 8, as well as each of the embodiments shown in FIGS. 7-13, may be used interchangeably with each other, and with the embodiments described more fully above. For example, the embodiment shown in FIG. 8 may further comprise a third layer comprising a nylon reinforced braid 52, such as a nylon 6 yarn. It may further comprise a fourth, outer layer 54 comprising a polyethylene material, such as a low density polyethylene. Examples of suitable widths of the layers just mentioned may be 0.0015 inches for the polyester film layer 110, 0.015 inches for the nylon reinforced braid layer, and 0.060 inches for the polyethylene layer. The nominal inner diameter for inner pipe 40 in the embodiment just described may be about 1.680 inches, with a nominal outer diameter of approximately 1.990 inches.

Referring now to FIG. 12, there is shown a preferred embodiment of the outer secondary containment pipe 42. This pipe 42 has an outer layer 116 having two opposed longitudinal edges 118, 120 in overlying relationship, the wrap being fabricated from a polyester film as described above. More specifically, outer pipe 42 comprises a first, inner layer 122 comprised of one of a polyethylene or an

ethylene vinyl acetate material. It is to be further understood that this layer **122** may be made of any suitable material including, but not limited to any of the exemplary outer pipe **42** materials listed more fully above. First layer **122** has a plurality of radially inwardly projecting flanges **64**.

Wrap layer **116** preferably may comprise a metallized film, and a third, outer layer **124** comprises any suitable polyethylene material.

As stated above, in a similar fashion, the diameters and cross-sectional widths of outer pipe **42** may be determined as desired. In a preferred embodiment, the wrap layer **116** is approximately 0.002 inches, and the outer pipe **42** nominal inner diameter may be 2.050 inches, and the nominal outer diameter may be 2.38 inches.

In addition to opposed edges **118, 120** being in overlying relationship as shown in FIG. **12**, these edges may also be butt sealed. Further, overlying edges **118, 120** may have a polyethylene based heat seal adhesive **126**, as shown with the embodiments in FIGS. **10, 11** and **13**. It is to be understood that these figures are slightly exaggerated for illustrative purposes, in that the edges in overlying relationship would be nearly undetectable, and, when the heat seal adhesive **126** is used, due to its polyethylene base, this will form a substantially undetectable seamless wrap.

Another alternate embodiment of the outer pipe **42** is shown in FIG. **7**. In this embodiment, the outer secondary containment pipe **42** comprises a wrap layer **128** having two opposed longitudinal edges in overlying relationship, the wrap being fabricated from a polyester film. This layer **128** may be used as a separating layer between outer pipe **42** and inner supply pipe **40**. A second layer **122** is comprised of one of a polyethylene and an ethylene vinyl acetate material, the second layer **122** having a plurality of radially inwardly projecting flanges **64**. A third layer **116** comprises a wrap having two opposed longitudinal edges, the wrap being fabricated from a metallized polyester film. A fourth layer **124** comprises a polyethylene material.

Referring now to FIG. **13**, there is shown an alternate embodiment of the outer layer **54** of inner pipe **40**. Outer layer **54'** of inner pipe **40** has a plurality of radially outwardly projecting flanges **130** extending from the outer surface **132** of outer layer **54'**. Modified first layer **122'** has a smooth inner surface and is comprised of one of a polyethylene and an ethylene vinyl acetate material. A second layer comprises a wrap **116** having two opposed longitudinal edges **118, 120** in overlying relationship, the wrap **116** being fabricated from a polyester film. A polyethylene based heat seal adhesive **126** extends between the overlying wrap edges **118, 120** and forms a seamless wrap. A third, outer layer **124** comprises a polyethylene material.

For any of the embodiments shown and those not specifically shown, any of the wrap layers may be "cigarette" wrapped or spiral wrapped, or wrapped by any other suitable method. Further, although one wrap, either simply in overlying relationship, butt sealed or adhesively sealed is sufficient to provide desirable barrier properties, two or more wraps may be successively applied to the inner pipe **40** and/or outer pipe **42**. When this is done, it is preferable to rotate the successive seams 180° from the seam of the immediately preceding wrap.

Further, each wrap does not have to be formed from exactly the same polyester film. For example, a first wrap layer may be formed from a polyester film; a second wrap layer may be formed from a copper foil, with the foil seam rotated 180° from the first polyester film seam; and a third wrap layer may comprise a polyester film, with the polyester film seam rotated 180° from the copper foil seam.

The addition of successive wraps is a safeguard in the event that the alcohol, hydrocarbon, or other environmentally unsafe fluid escapes through the seam of the first wrap. If this did occur, such fluid would have to travel a full 180° in order to escape from the seam of a second wrap; if such occurred, the fluid would have to turn around and travel a full 180° to escape from a third wrap, and so on. It can be seen that, since there is little likelihood that such fluid would escape from the first seam, the chance of the fluid traveling in such a manner through a second, third, fourth, etc. wrap to eventually escape is substantially non-existent. As such, a point of diminishing returns may be reached, and the manufacturer and/or user, may see no necessity in providing more than perhaps one or two barrier film wraps.

Two such wraps are shown in FIG. **9**, and are designated as **110, 134**. Wrap **110** has opposed overlying edges **112, 114**; and wrap **134** has opposed overlying edges **136, 138**. As can be seen in FIG. **9**, the seam formed by edges **136, 138** is rotated 180° from the seam formed by edges **112, 114**.

With any of the single or multiple wrap layers shown, the polyester film may be a metallized polyester film, as stated above. Further, this metallized polyester film more specifically may be aluminized. Further, the wrap layer may be comprised of a polyvinyl fluoride coated polyester film, or a polytetrafluoroethylene plastic-impregnated polyester film. One such polytetrafluoroethylene plastic material is commercially available from E. I. du Pont de Nemours Company under the trade name TEFLON.

Further, the polyethylene based heat seal adhesive **126** may be used in any of the embodiments shown or described. The heat seal adhesive is shown used in FIG. **10** with a single wrap over inner layer **50**. The embodiment shown in FIG. **10** may preferably be suitable for suction piping and/or vent piping. Further, as in FIG. **11**, the heat seal adhesive **126** may be used in conjunction with a second wrap non-adhesively sealed. The second wrap is designated as **110'**, with opposed longitudinal edges **112', 114'**. The embodiment shown in FIG. **11** may preferably be suitable for pressure piping. It is to be understood that the adhesive may be coated in any suitable quantity on the inner or outer surface of wrap layers. Further, in the embodiment shown in FIG. **12**, the wrap layer **116** is adhesively coated along its entire outer surface to outer layer **124** by adhesive **140**.

Some of the many advantages of using a wrapped barrier film layer are as follows. The addition of extra extruders and the time, expense and general problems involved in coextruding is substantially eliminated. Further, since the wrap is applied at a simple and conventional wrapping machine, it allows a manufacturer to use materials like the polyvinyl fluoride coated MYLAR, which material would be very difficult to set up in a coextrusion process.

In an alternate embodiment not shown, the secondary containment system may comprise an inner supply pipe comprising a first layer of crosslinked polyethylene; a second layer comprised of a wire helix material; a third layer comprised of a polyester fiber reinforcing material; and a fourth layer comprised of an oil and gasoline resistant nitrile cover. The outer pipe **42** may be as generally described hereinabove.

It is to be further understood that the barrier films of the alternate preferred embodiment may be used in secondary containment systems having removable/replaceable inner supply pipes, such as any of those systems mentioned hereinabove having rigid outer secondary containment pipes or a combination of rigid straight pipe with the larger diameter, convoluted plastic pipe. Any of the embodiments

of inner supply pipe 40 having one or more barrier film wraps described above, including those embodiments shown in FIGS. 7-13, may be used in conjunction with such a removable or replaceable secondary containment system.

Still further, it is to be understood that the barrier films of the alternate preferred embodiment may be used in primary piping systems. Primary piping systems contemplated include, but are not limited to automotive fuel lines, chemical plant hose, and tank truck hose for unloading, for example, gasoline. Depending upon the application, these primary piping systems may be buried in the ground, run through buildings, motor vehicles, etc. The barrier films mentioned above may prove particularly useful when such primary piping systems are transporting hazardous fluids. Any of the embodiments of inner supply pipe 40 having one or more barrier film wraps described above, including those embodiments shown in FIGS. 7-13, may be adapted for use in conjunction with such primary piping systems. Further, it is contemplated that the outer secondary containment pipe 42 is described above, including any embodiments shown in FIGS. 7-13, may also prove useful in some circumstances in the chemical, automotive, etc. applications listed above.

While preferred embodiments of the invention have been described in detail, it will be apparent to those skilled in the art that the disclosed embodiments may be modified. Therefore, the foregoing description is to be considered exemplary rather than limiting, and the true scope of the invention is that defined in the following claims.

What is claimed is:

1. A secondary containment piping system, comprising an inner supply pipe, and a flexible, hazardous fluid-impervious outer secondary containment pipe, within which the inner supply pipe is carried, one of an outer surface of the inner supply pipe and an inner surface of the outer pipe having a plurality of radially outwardly projecting flanges adapted to engage the other of the outer surface of the inner supply pipe and the inner surface of the outer pipe when the pipes are buried to provide a locking engagement of the pipes with respect to each other, and to provide for a flow passage between the pipes, the improvement comprising:

- a first, inner layer of the inner pipe being fabricated from nylon;
- a second layer comprising a wrap having two opposed longitudinal edges in overlying relationship, the wrap being fabricated from a polyester film;
- a third layer comprising a nylon reinforced braid; and
- a fourth, outer layer comprising a polyethylene material.]

2. The secondary containment piping system as defined in claim 1 wherein the outer secondary containment pipe has an outer layer comprising a wrap having two opposed longitudinal edges in overlying relationship, the wrap being fabricated from a polyester film.]

3. [The secondary containment piping system as defined in claim 1] A secondary containment piping system, comprising an inner supply pipe, and a flexible, hazardous fluid-impervious outer secondary containment pipe, within which the inner supply pipe is carried, one of an outer surface of the inner supply pipe and an inner surface of the outer pipe having a plurality of radially projecting flanges adapted to engage the other of the outer surface of the inner supply pipe and the inner surface of the outer pipe when the pipes are buried to provide a locking engagement of the pipes with respect to each other, and to provide for a flow passage between the pipes, the improvement comprising:

- a first, inner layer of the inner pipe being fabricated from nylon;

a second layer comprising a wrap having two opposed longitudinal edges in overlying relationship, the wrap being fabricated from a polyester film;

a third layer comprising a nylon reinforced braid; and

a fourth, outer layer comprising a polyethylene material;

wherein the outer secondary containment pipe comprises:

a first, inner layer comprised of one of a polyethylene and an ethylene vinyl acetate material, the first layer having a plurality of radially projecting flanges;

a second layer comprising a wrap having two opposed longitudinal edges, the wrap being fabricated from a metallized polyester film; and

a third, outer layer comprising a polyethylene material.

4. The secondary containment piping system as defined in claim 3 wherein the opposed edges are in overlying relationship.

5. The secondary containment piping system as defined in claim 3 wherein the opposed edges are butt sealed.

6. The secondary containment piping system as defined in claim 3 wherein the opposed edges are in overlying relationship, the piping system further comprising a polyethylene based heat seal adhesive extending between the overlying wrap edges and forming a seamless wrap.

7. [The secondary containment piping system as defined in claim 1] A secondary containment piping system, comprising an inner supply pipe, and a flexible, hazardous fluid-impervious outer secondary containment pipe, within which the inner supply pipe is carried, one of an outer surface of the inner supply pipe and an inner surface of the outer pipe having a plurality of radially projecting flanges adapted to engage the other of the outer surface of the inner supply pipe and the inner surface of the outer pipe when the pipes are buried to provide a locking engagement of the pipes with respect to each other, and to provide for a flow passage between the pipes, the improvement comprising:

a first, inner layer of the inner pipe being fabricated from nylon;

a second layer comprising a wrap having two opposed longitudinal edges in overlying relationship, the wrap being fabricated from a polyester film;

a third layer comprising a nylon reinforced braid; and

a fourth, outer layer comprising a polyethylene material;

wherein the outer secondary containment pipe comprises:

a first, inner layer comprising a wrap having two opposed longitudinal edges in overlying relationship, the wrap being fabricated from a polyester film;

a second layer comprised of one of a polyethylene and an ethylene vinyl acetate material, the second layer having a plurality of radially inwardly projecting flanges;

a third layer comprising a wrap having two opposed longitudinal edges in overlying relationship, the wrap being fabricated from a metallized polyester film; and

a fourth, outer layer comprising a polyethylene material.

8. [The secondary containment piping system as defined in claim 1] A secondary containment piping system, comprising an inner supply pipe, and a flexible, hazardous fluid-impervious outer secondary containment pipe, within which the inner supply pipe is carried, one of an outer surface of the inner supply pipe and an inner surface of the outer pipe having a plurality of radially projecting flanges adapted to engage the other of the outer surface of the inner supply pipe and the inner surface of the outer pipe when the pipes are buried to provide a locking engagement of the pipes with respect to each other, and to provide for a flow passage between the pipes, the improvement comprising:

a first, inner layer of the inner pipe being fabricated from nylon;

a second layer comprising a wrap having two opposed longitudinal edges in overlying relationship, the wrap being fabricated from a polyester film;

a third layer comprising a nylon reinforced braid; and

a fourth, outer layer comprising a polyethylene material;

wherein the inner pipe outer surface has a plurality of radially outwardly projecting flanges, and wherein the outer pipe is comprised of:

a first, inner layer comprised of one of a polyethylene and an ethylene vinyl acetate material;

a second layer comprising a wrap having two opposed longitudinal edges in overlying relationship, the wrap being fabricated from a polyester film;

a polyethylene based heat seal adhesive extending between the overlying wrap edges and forming a seamless wrap; and

a third, outer layer comprising a polyethylene material.

9. [The secondary containment piping system as defined in claim 1] *A secondary containment piping system, comprising an inner supply pipe, and a flexible, hazardous fluid-impervious outer secondary containment pipe, within which the inner supply pipe is carried, one of an outer surface of the inner supply pipe and an inner surface of the outer pipe having a plurality of radially projecting flanges adapted to engage the other of the outer surface of the inner supply pipe and the inner surface of the outer pipe when the pipes are buried to provide a locking engagement of the pipes with respect to each other, and to provide for a flow passage between the pipes, the improvement comprising:*

a first, inner layer of the inner pipe being fabricated from nylon;

a second layer comprising a wrap having two opposed longitudinal edges in overlying relationship, the wrap being fabricated from a polyester film;

a third layer comprising a nylon reinforced braid; and

a fourth, outer layer comprising a polyethylene material;

wherein the second layer overlying edges form a first seam, and wherein the inner pipe further comprises:

a first intermediate layer, disposed between the second layer and a second intermediate layer, comprising a wrap having two opposed longitudinal edges in overlying relationship, the overlying edges forming a second seam, the second seam being rotated 180° from the first seam, the wrap being fabricated from a copper foil; and

the second intermediate layer disposed between the first intermediate layer and the third layer, comprising a wrap having two opposed longitudinal edges in overlying relationship, the overlying edges forming a third seam, the third seam being rotated 180° from the second seam, the wrap being fabricated from a polyester film.

10. The secondary containment piping system as defined in claim [1] 3 wherein the second, wrap layer is fabricated from a polyvinyl fluoride coated polyester film.

11. The secondary containment piping system as defined in claim [1] 3 wherein the second layer is fabricated from a polytetrafluoroethylene plastic-impregnated polyester film.

[12. The secondary containment piping system as defined in claim 1 wherein the second layer is fabricated from a metallized polyester film.]

13. The secondary containment piping system as defined in claim [12] 14 wherein the metallized polyester film is aluminized.

14. [The secondary containment piping system as defined in claim 12, further comprising] *A secondary containment piping system, comprising an inner supply pipe, and a flexible, hazardous fluid-impervious outer secondary containment pipe, within which the inner supply pipe is carried, one of an outer surface of the inner supply pipe and an inner surface of the outer pipe having a plurality of radially projecting flanges adapted to engage the other of the outer surface of the inner supply pipe and the inner surface of the outer pipe when the pipes are buried to provide a locking engagement of the pipes with respect to each other, and to provide for a flow passage between the pipes, the improvement comprising:*

a first, inner layer of the inner pipe being fabricated from nylon;

a second layer comprising a wrap having two opposed longitudinal edges in overlying relationship, the wrap being fabricated from a polyester film;

a third layer comprising a nylon reinforced braid;

a fourth, outer layer comprising a polyethylene material; and

a polyethylene based heat seal adhesive extending between the overlying wrap edges and forming a seamless wrap.

15. [The secondary containment piping system as defined in claim 1] *A secondary containment piping system, comprising an inner supply pipe, and a flexible, hazardous fluid-impervious outer secondary containment pipe, within which the inner supply pipe is carried, one of an outer surface of the inner supply pipe and an inner surface of the outer pipe having a plurality of radially projecting flanges adapted to engage the other of the outer surface of the inner supply pipe and the inner surface of the outer pipe when the pipes are buried to provide a locking engagement of the pipes with respect to each other, and to provide for a flow passage between the pipes, the improvement comprising:*

a first, inner layer of the inner pipe being fabricated from nylon;

a second layer comprising a wrap having two opposed longitudinal edges in overlying relationship, the wrap being fabricated from a polyester film;

a third layer comprising a nylon reinforced braid; and

a fourth, outer layer comprising a polyethylene material;

wherein the second layer overlying edges form a first seam, the second layer wrap being fabricated from a metallized polyester film, and wherein the inner pipe further comprises:

a polyethylene based heat seal adhesive extending between the second layer overlying wrap edges and forming a seamless wrap; and

an intermediate layer, disposed between the second layer and the third layer, comprising a wrap having two opposed longitudinal edges in overlying relationship, the overlying edges forming a second seam, the second seam being rotated 180° from the first seam, the wrap being fabricated from a polyvinyl fluoride coated polyester film.

16. A secondary containment piping system, comprising an inner supply pipe, and a flexible, fuel impervious outer secondary containment pipe, within which the inner supply pipe is carried, one of an outer surface of the inner supply pipe and an inner surface of the outer pipe having a plurality of radially [outwardly] projecting flanges adapted to engage the other of the outer surface of the inner supply pipe and the inner surface of the outer pipe when the pipes are buried to provide a locking engagement of the pipes with respect to each other, and to provide for a flow passage between the pipes, the improvement comprising:

the inner supply pipe, comprising:

- a first, inner layer fabricated from nylon;
- a second layer comprising a wrap having two opposed longitudinal edges in overlying relationship, the overlying edges forming a first seam, the wrap being fabricated from a metallized polyester film;
- a polyethylene based heat seal adhesive extending between the overlying wrap edges and forming a seamless wrap;
- a third layer comprising a wrap having two opposed longitudinal edges in overlying relationship, the overlying edges forming a second seam, the second seam being rotated 180° from the first seam, the wrap being fabricated from a polyvinyl fluoride coated polyester film;
- a fourth layer comprising a nylon reinforced braid; and
- a fifth, outer layer comprising a polyethylene material; and

the outer secondary containment pipe, comprising:

- a first, inner layer comprising a wrap having two opposed longitudinal edges in overlying relationship, the wrap being fabricated from a polyester film;
- a second layer comprised of one of a polyethylene and an ethylene vinyl acetate material, the second layer having a plurality of radially inwardly projecting flanges;
- a third layer comprising a wrap having two opposed longitudinal edges, the wrap being fabricated from a metallized polyester film; and
- a fourth, outer layer comprising a polyethylene material.

17. The secondary containment system as defined in claim 16 wherein the third layer is adhesively bonded to the fourth layer.

18. A secondary containment piping system, comprising an inner supply pipe, and a flexible, fuel impervious outer secondary containment pipe, within which the inner supply pipe is carried, one of an outer surface of the inner supply pipe and an inner surface of the outer pipe having a plurality of radially [outwardly] projecting flanges adapted to engage the other of the outer surface of the inner supply pipe and the inner surface of the outer pipe when the pipes are buried to provide a locking engagement of the pipes with respect to each other, and to provide for a flow passage between the pipes, the secondary containment piping system further comprising spaced, underground chambers which are interconnected in a fluid tight manner through walls thereof by the secondary containment pipe which passes therethrough, the inner supply pipe having end couplings attached to the ends thereof, the end couplings being disposed within the chambers at a point beyond the termination of the outer secondary containment pipe, the inner and outer pipes being impervious to the fluids to be transmitted therethrough, the improvement comprising:

the inner supply pipe, comprising:

- a first, inner layer fabricated from nylon;
- a second layer comprising a wrap having two opposed longitudinal edges in overlying relationship, the wrap being fabricated from a polyester film;
- a third layer comprising a nylon reinforced braid; and
- a fourth layer comprising a polyethylene material; and

the outer secondary containment pipe, comprising:

- a first layer comprised of one of a polyethylene and an ethylene vinyl acetate material, the first layer having a plurality of radially inwardly projecting flanges;

a second layer comprising a wrap having two opposed longitudinal edges, the wrap being fabricated from a metallized polyester film; and

a third, outer layer comprising a polyethylene material.

19. The secondary containment piping system as defined in claim 18, wherein the second layer overlying edges form a first seam, the second layer wrap being fabricated from a metallized polyester film, and wherein the inner supply pipe further comprises:

a polyethylene based heat seal adhesive extending between the second layer overlying wrap edges and forming a seamless wrap; and

an intermediate layer, disposed between the second layer and the third layer, comprising a wrap having two opposed longitudinal edges in overlying relationship, the overlying edges forming a second seam, the second seam being rotated 180° from the first seam, the wrap being fabricated from a polyvinyl fluoride coated polyester film;

and wherein the outer secondary containment pipe further comprises a separating layer extending around the outer pipe first layer, the separating layer comprising a wrap having two opposed longitudinal edges in overlying relationship, the wrap being fabricated from a polyester film.

20. A secondary containment piping system, comprising an inner supply pipe, and a hazardous fluid-impervious outer secondary containment pipe, within which the inner supply pipe is carried, a flow passage being defined between the pipes, the improvement comprising:

a first, inner layer of the inner pipe being fabricated from nylon;

a second layer comprising a wrap having two opposed longitudinal edges in overlying relationship, the wrap being fabricated from a polyester film;

a third layer comprising a nylon reinforced braid; and

a fourth, outer layer comprising a polyethylene material.]

21. [The secondary containment piping system as defined in claim 20] A secondary containment piping system, comprising an inner supply pipe, and a hazardous fluid-impervious outer secondary containment pipe, within which the inner supply pipe is carried, one of an outer surface of the inner supply pipe and an inner surface of the outer pipe having a plurality of radially projecting flanges adapted to engage the other of the outer surface of the inner supply pipe and the inner surface of the outer pipe when the pipes are buried to provide a locking engagement of the pipes with respect to each other, and to provide for a flow passage between the pipes, the improvement comprising:

a first, inner layer of the inner pipe being fabricated from nylon;

a second layer comprising a wrap having two opposed longitudinal edges in overlying relationship, the wrap being fabricated from a polyester film;

a third layer comprising a nylon reinforced braid; and

a fourth, outer layer comprising a polyethylene material;

wherein the second layer overlying edges form a first seam, the second layer wrap being fabricated from a metallized polyester film, and wherein the inner pipe further comprises:

a polyethylene based heat seal adhesive extending between the second layer overlying wrap edges and forming a seamless wrap; and

an intermediate layer, disposed between the second layer and the third layer, comprising a wrap having two opposed longitudinal edges in overlying relationship, the overlying edges forming a second seam, the second seam being rotated 180° from the first seam, the wrap being fabricated from a polyvinyl fluoride coated polyester film.