



US00RE37091E

(19) **United States**
(12) **Reissued Patent**
Tanaka et al.

(10) **Patent Number: US RE37,091 E**
(45) **Date of Reissued Patent: Mar. 13, 2001**

(54) **MOTION COMPENSATED PREDICTION INTERFRAME CODING SYSTEM**

4,821,119 * 4/1989 Gharai 348/402
4,972,260 * 11/1990 Fujikawa et al. 348/405
4,984,076 * 1/1991 Watanabe et al. 348/405
5,016,010 * 5/1991 Sugiyama 341/67

(75) Inventors: **Akiyoshi Tanaka**, Kawasaki; **Satoshi Matsuya**, deceased, late of Sagamihara, by Yasue Matsuya, legal heir; **Wataru Fujikawa**, Yokohama; **Hiroyuki Uwabo**, Tokyo; **Ikuo Inoue**, Yokohama; **Atsushi Nagata**, Katano, all of (JP)

OTHER PUBLICATIONS

Multidimensional Signal Processing of TV Picture, Nikkan Kogyo Shinbun Company, Chapter 7 "Efficient Coding", pp. 213-291 (Nov. 15, 1988).*

(73) Assignee: **Matsushita Electric Industrial Co., Ltd.**, Osaka (JP)

CCITT (Comite Consultatif Internationale Telegraphique et Telephonique) SGXV Document # 525: Description of Ref. Model 8 (RM 8), Working Party XV/4 Specialist Group on Coding for Visual Telephony (Jun. 9, 1989).*

(21) Appl. No.: **08/298,684**

(22) Filed: **Aug. 31, 1994**

Related U.S. Patent Documents

Reissue of:

(64) Patent No.: **5,144,426**
Issued: **Sep. 1, 1992**
Appl. No.: **07/597,853**
Filed: **Oct. 12, 1990**

* cited by examiner

Primary Examiner—Howard Britton

(74) *Attorney, Agent, or Firm*—Lowe Hauptman Gopstein Gilman & Berner

(30) **Foreign Application Priority Data**

Oct. 13, 1989 (JP) 1-266478
Oct. 13, 1989 (JP) 1-266479
Jan. 19, 1990 (JP) 2-11284
Jun. 19, 1990 (JP) 2-160520

(57) **ABSTRACT**

A motion compensated prediction interframe coding system which first measures characteristics regarding the fineness of a pattern or texture of a picture, which is represented by an input television signal and is divided into a group of continuous blocks each quantized by using a quantization step size, and changes the quantization step size into a smaller one if quantizes a block having a picture pattern or texture finer than patterns of the other blocks. Thereby, an amount of generated codes can be limited but a motion compensated prediction frame coding operation can be performed without degrading the fineness of the texture of the original input picture.

(51) **Int. Cl.**⁷ **H04N 7/50**
(52) **U.S. Cl.** **348/409; 348/400; 348/405; 348/416; 348/420**
(58) **Field of Search** 348/400, 402, 348/405, 409, 416, 419, 420; H04N 7/133, 7/137, 7/30, 7/50

(56) **References Cited**

U.S. PATENT DOCUMENTS

4,517,596 * 5/1985 Suzuki 348/419

33 Claims, 7 Drawing Sheets

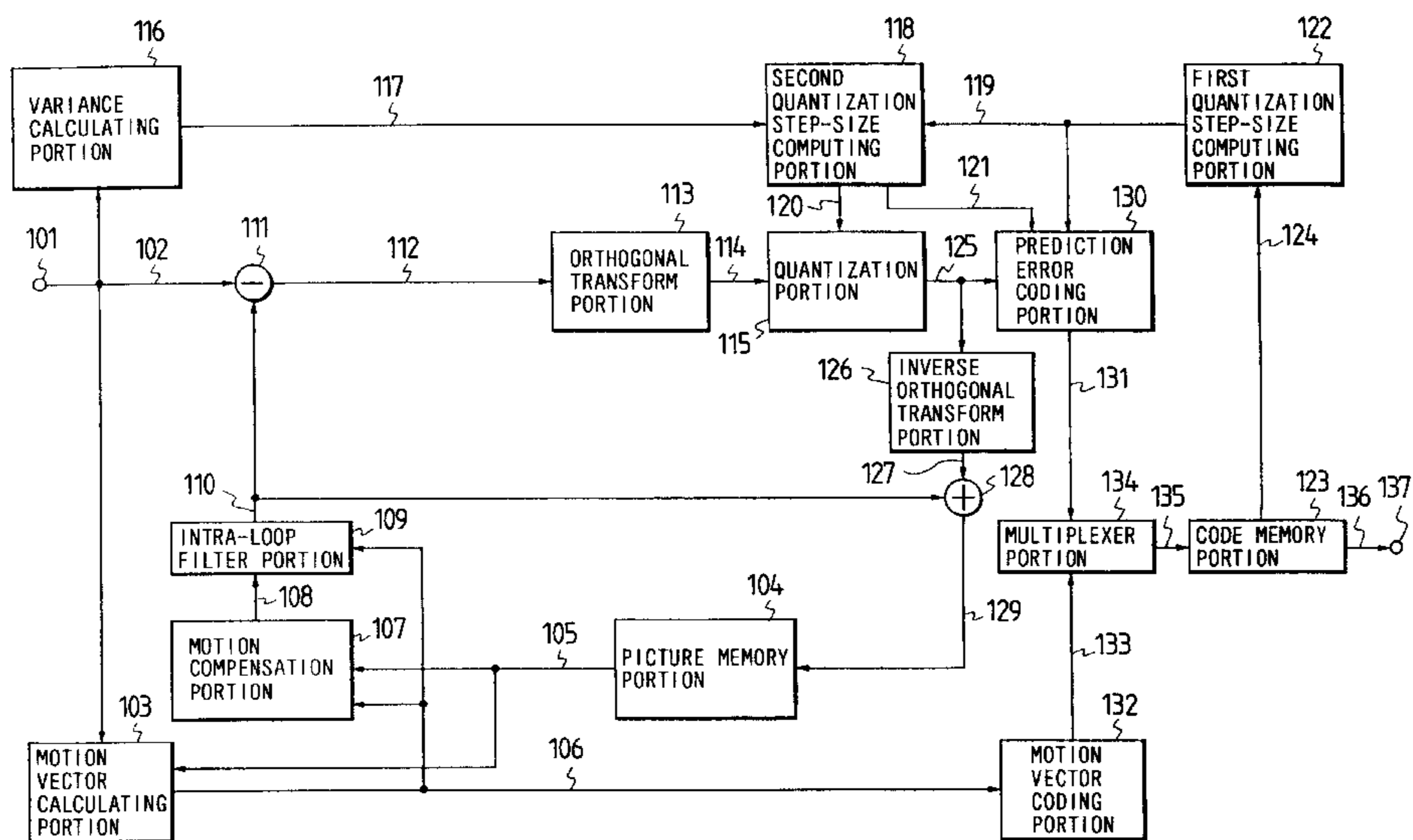

FIG. 1 PRIOR ART

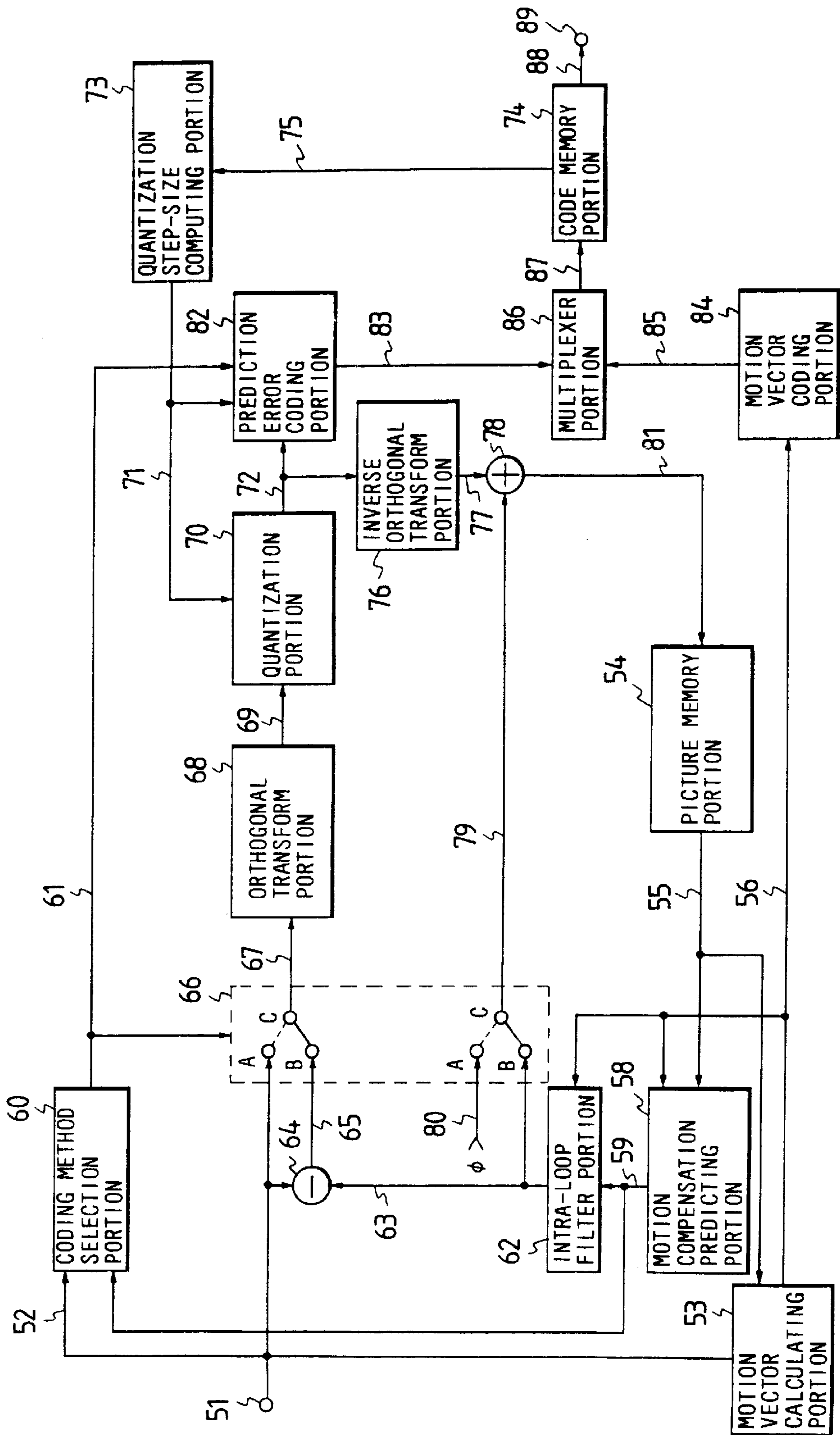

FIG. 2

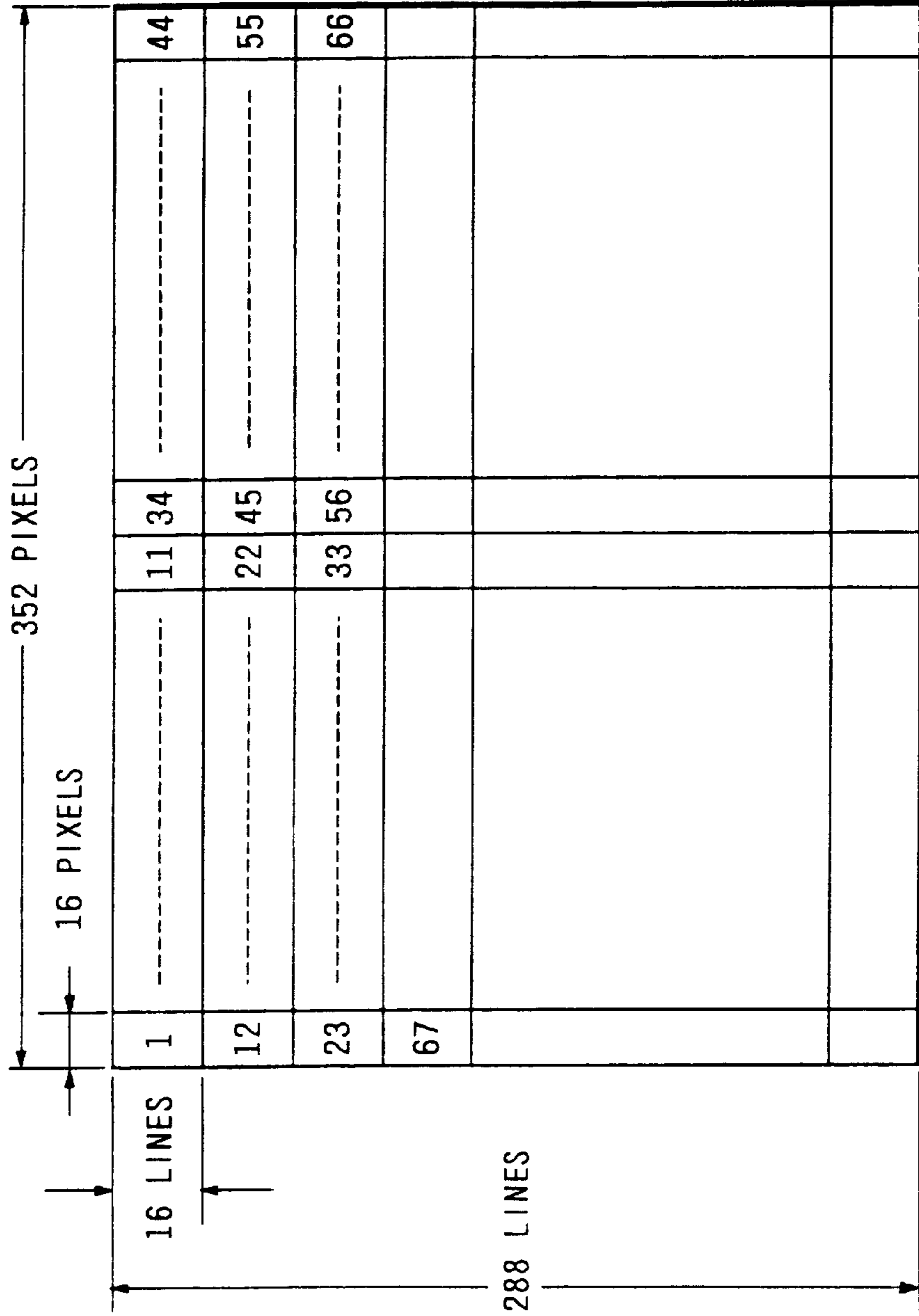

FIG. 3

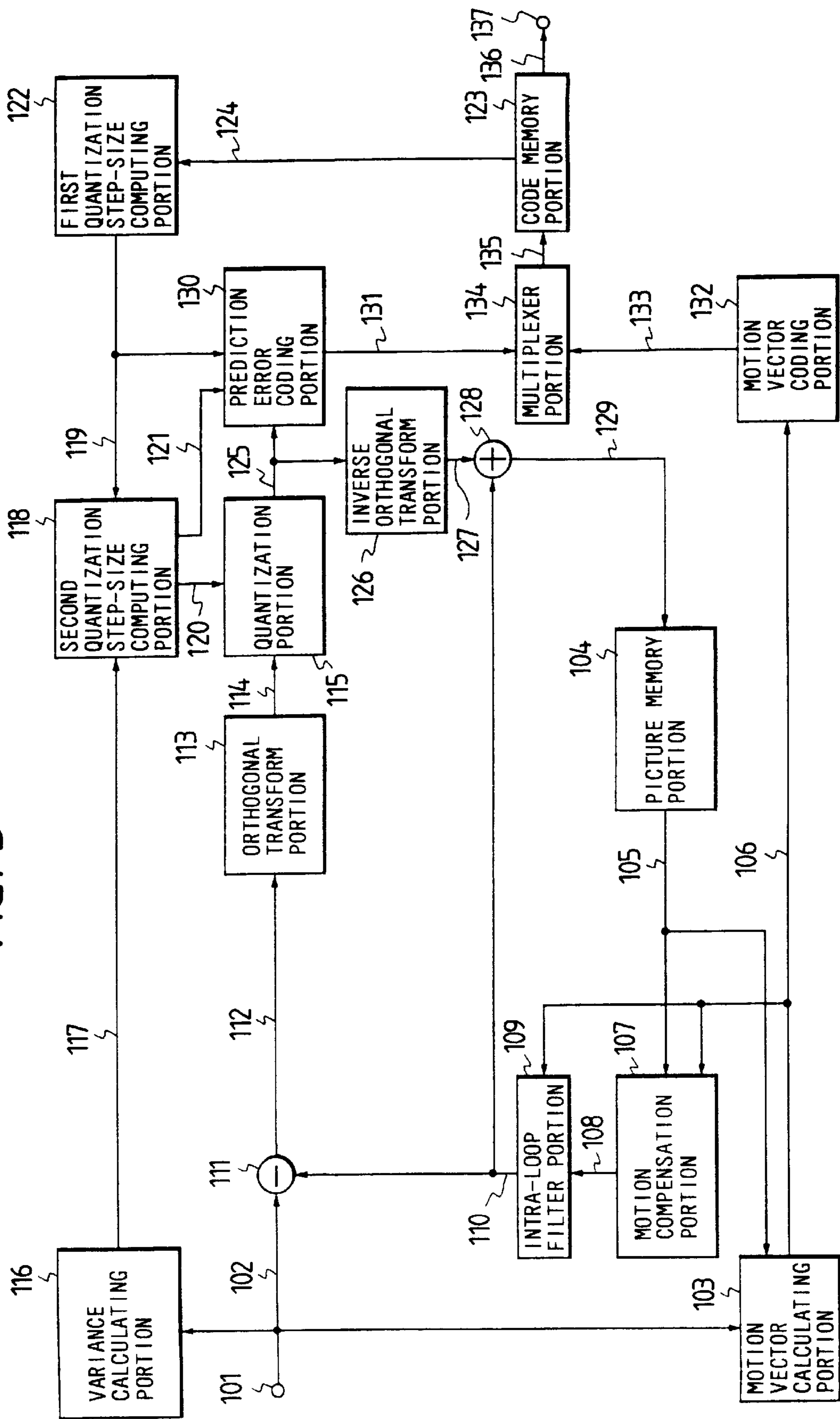

FIG. 4

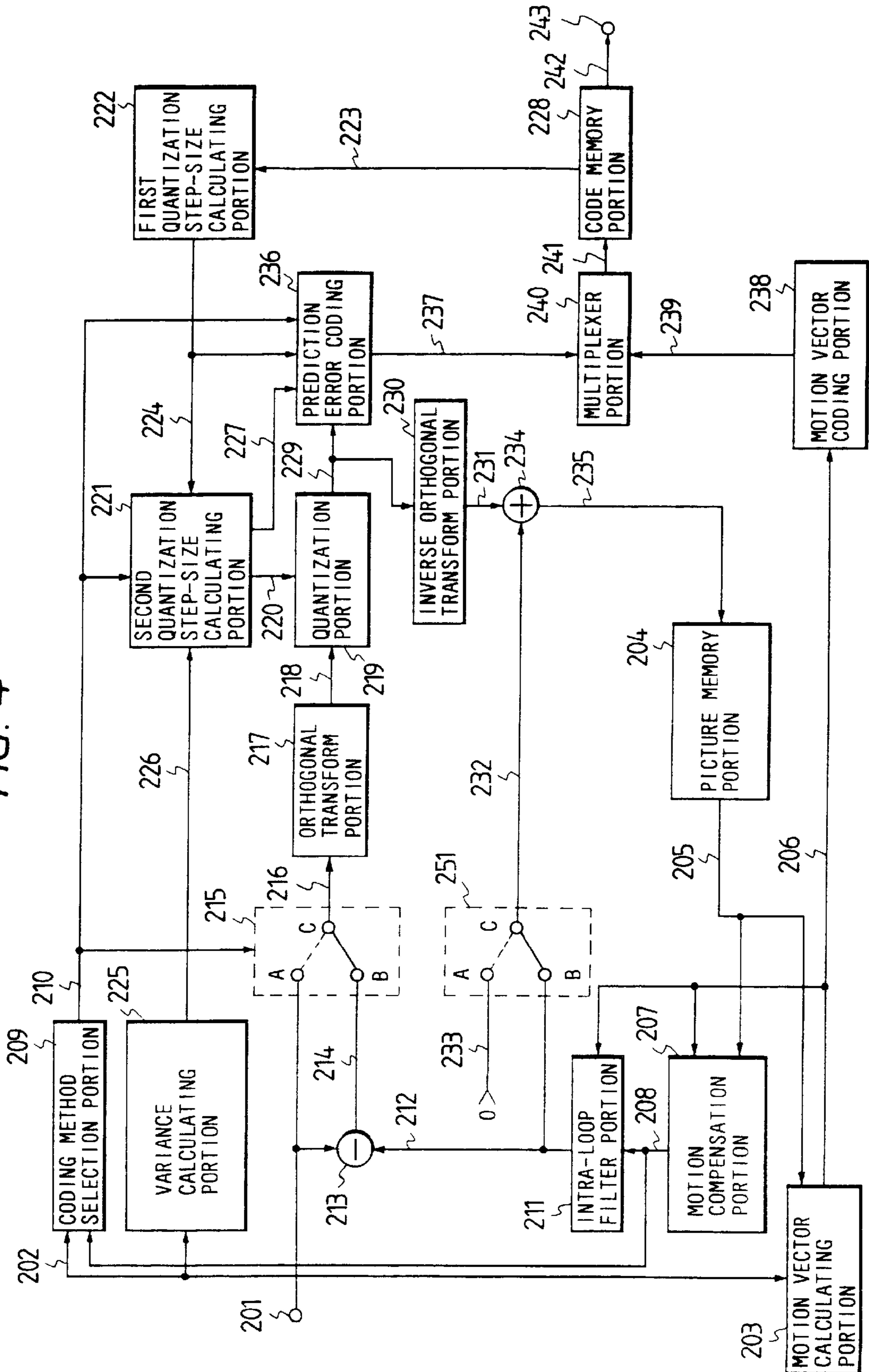

FIG. 6

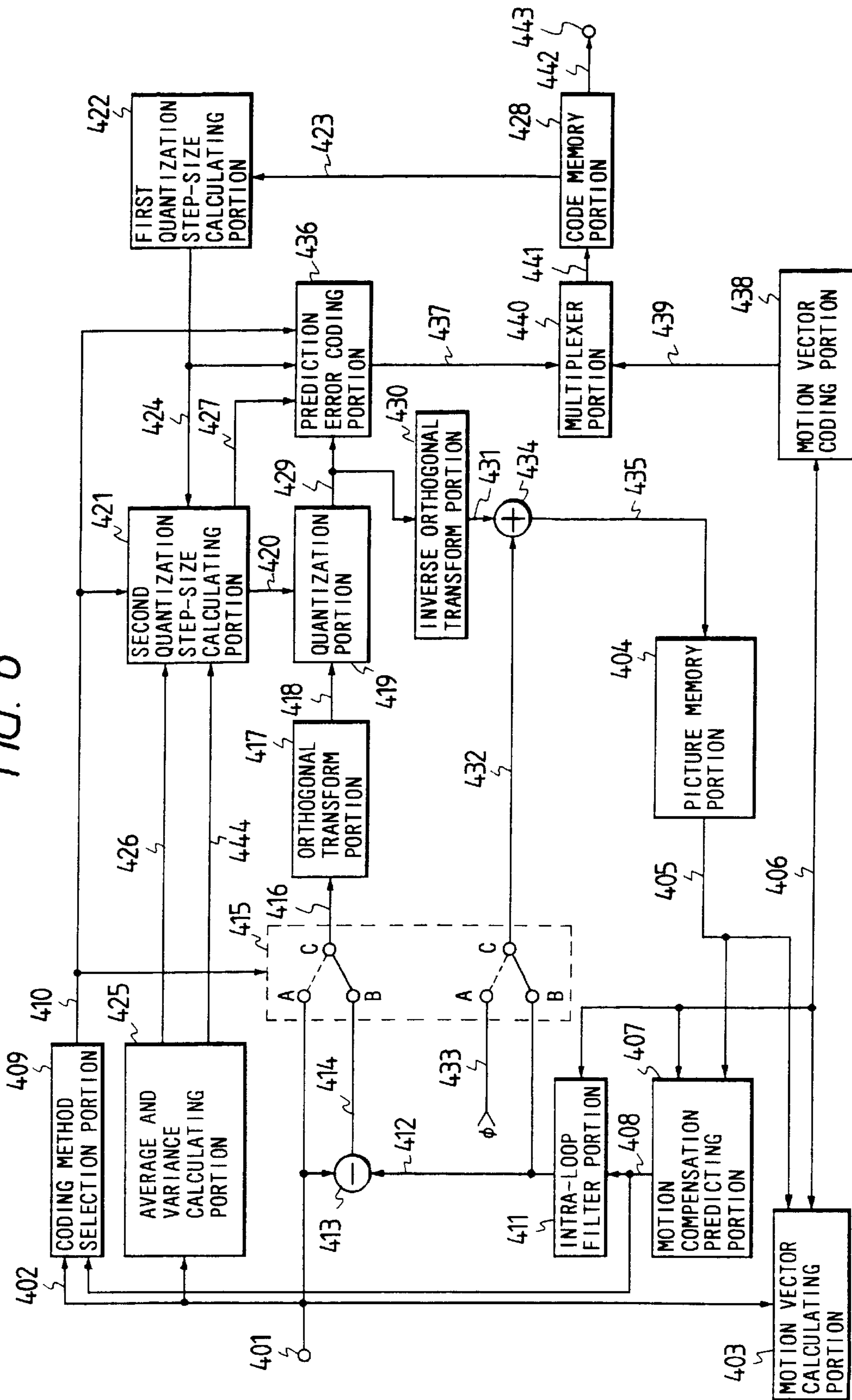
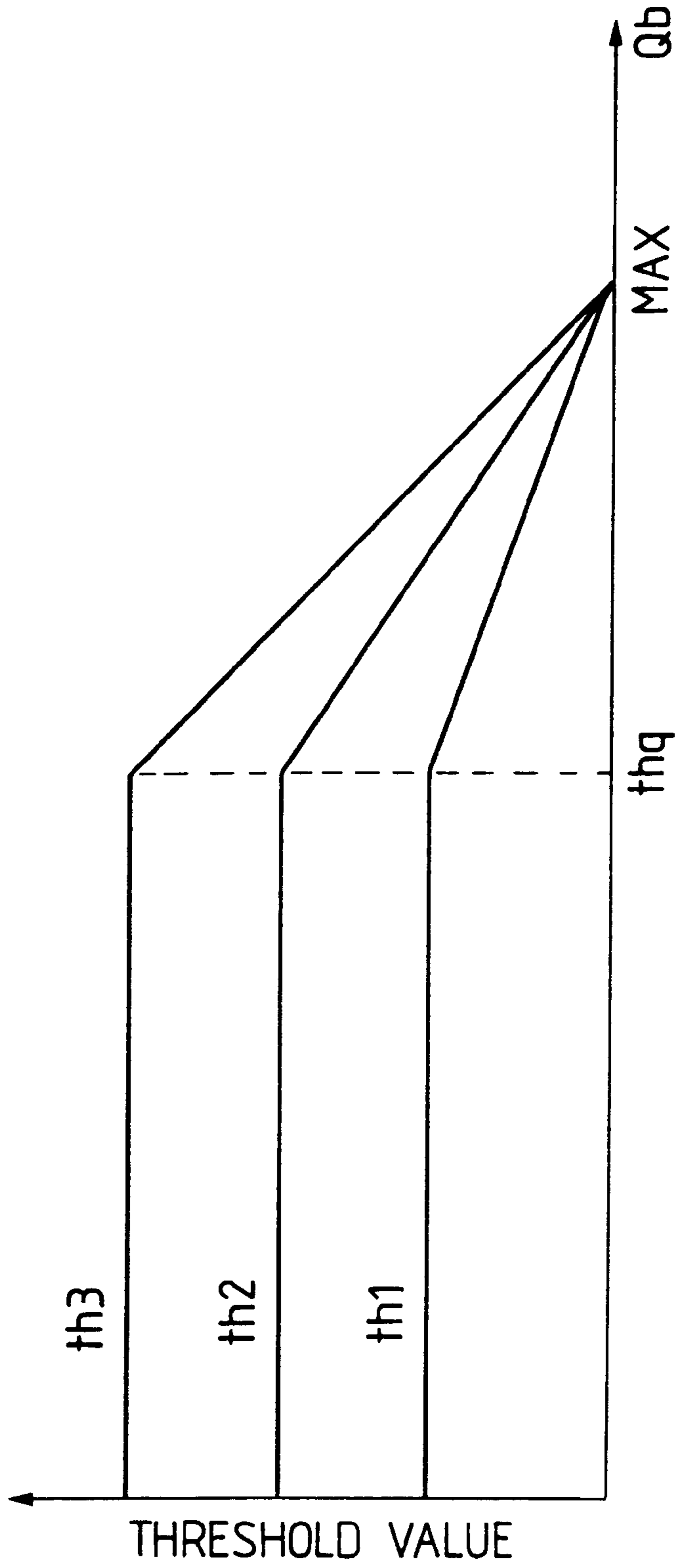

FIG. 7



MOTION COMPENSATED PREDICTION INTERFRAME CODING SYSTEM

Matter enclosed in heavy brackets [] appears in the original patent but forms no part of this reissue specification; matter printed in italics indicates the additions made by reissue.

BACKGROUND OF THE INVENTION

1. Field of the Invention

This invention generally relates to a television system and more particularly to a motion compensated prediction interframe system for performing motion compensated prediction interframe coding of television signals.

2. Description of the Related Art

Recently, with advance in techniques of moving picture coding, a motion compensated prediction interframe coding system has been developed as an efficient coding system for effecting an efficient coding of a color moving picture for use in a visual telephone (or video telephone), a video conference system, CD ROM, a digital video tape recorder (VTR) and so on. An example of a motion compensated prediction interframe coding system is described in T. Fukinuki: Multidimensional Signal Processing of TV Picture, Nikkan Kogyo Shinbun Company, Chapter 7 "Efficient Coding", pp. 213-291 (1988. 11. 15).

When a large quantity of prediction error signals is generated, the motion compensated prediction interframe coding system limits an amount of codes of the generated prediction error signals by employing a large step size for quantization (hereunder sometimes referred to as a quantization step size) in such a way that at the coding of a picture can be achieved a constant frame rate. An example of a conventional method of determining a step size for quantization is disclosed in CCITT (Comite Consultatif Internationale Telegraphique et Telephonique) SGXV Document #525: Description of Ref. Model 8 (RM 8), Working Party XV/4 Specialist Group on Coding for Visual Telephony (1989. 6. 9).

Hereinafter, a prior art motion compensated prediction interframe coding system will be describe by referring to FIG. 1.

In this figure, reference numeral **51** represents an input terminal from which television signals are inputted to the system; **53** a motion vector calculating portion for comparing a picture signal of a block (hereunder referred to as a coding block), which is to be coded, of a current frame with a reproduced picture signal of a previous frame and calculating a motion vector; **54** a picture memory portion for storing reproduced picture signals of a current and previous frames; **58** a motion compensation predicting portion for performing a motion compensation predicting of the reproduced picture signals of the pervious frame; **60** a coding method selection portion for selecting a method of coding of a block from an interframe coding and intraframe coding methods; **62** an intra-loop filter portion for performing two-dimensional lowpass filtering processing of a motion compensation predicting signal; **64** a prediction error evaluating portion for evaluating a prediction error by computing the difference between an original picture signal and a predictive signal of a coding block; **66** a switch portion for selecting a signal, of which an orthogonal transform is effected, in accordance with a coding method selecting signal and further selecting a signal from which a reproduced picture is calculated; **68** an orthogonal transform portion for performing an orthogonal transform of the

selected signal; **70** a quantization portion for quantizing coefficients of an orthogonal transform (hereunder referred to as orthogonal transform coefficients) of the selected signal; **73** a quantization step-size computing portion for computing a step size for the quantization; **74** a code memory portion for temporarily storing a transmission frame; **76** an inverse orthogonal transform portion for effecting an inverse orthogonal transform of the quantized coefficients of the orthogonal transform; **78** a reproduced picture calculating portion for calculating a reproduced picture of a current frame; **82** a prediction error coding portion for performing what is called "transmitting channel coding" of a prediction error; **84** a motion vector coding portion for performing the transmitting channel coding of a motion vector; **86** a multiplexer portion for computing a transmitting frame on the basis of the prediction code and the motion vector; and **89** an output terminal from which a transmission signal is output.

Hereinafter, an operation of the prior art motion compensated prediction interframe coding system having the above described arrangement will be described.

First, television signals are converted into digital television signals by an analog-to-digital (A/D) conversion circuit (not shown). Then, pixels represented by the digital television signals are divided into blocks each of which is a rectangular array composed of M×N pixels arranged in M columns and N rows. Further, the digital television signals are input to the system from the input terminal **51** as input television signals **52**. Then, the motion vector calculating portion **53** compares the input television signal with a reproduced picture signal **55** of a previous frame stored in the picture memory portion **54** and calculating the motion of a coding block as a motion vector and moreover outputs a motion vector signal **56** representing the motion vector. Simultaneously, the motion vector calculating portion **53** judges from the result of the evaluation of the motion vector whether the motion compensation made with respect to the coding block is effective or ineffective. Further, the motion vector calculating portion **53** outputs a motion compensation control signal which represents the result of the judgement and is superposed on the motion vector signal **56**.

The motion compensation prediction portion **58** performs a motion compensation prediction of the reproduced television signal **55** of a previous frame in case where the motion compensation control signal indicates that the motion compensation prediction is effective and outputs the reproduced television signal without change as a motion compensation prediction signal **59** in case where the motion compensation control signal indicates that the motion compensation prediction is ineffective.

The coding method selection portion **60** compares the input television signal **52** with the motion compensation prediction signal **59** every block and judges whether or not the motion compensation prediction is effective. Further, the coding method selection portion **60** judges that an intraframe coding method is effective for a current block in question in case where the motion compensation prediction is effective and that an interframe coding method is effective for a current block in question in case where the motion compensation prediction is not effective, and outputs a coding method selection signal **61** representing the result of this judgement. In this way, a coding method to be used in coding each block may be changed from the intraframe coding method to the interframe coding method and vice versa. This can make the following improvements on another conventional system which employs only the interframe coding method:

(1) Picture quality can be improved after a scene is changed because the intraframe coding method is employed when the scene is changed.

(2) Picture quality can be also improved when a moving body largely moves because a background which has hid itself behind the moving body emerges from behind it and in such a case, the intraframe coding is employed.

Incidentally, in case of a coding method employed in storage type media such as CD ROM, it is necessary to insert a frame of which all blocks are coded by performing the intraframe coding method (hereunder referred to as a refreshment frame) between frames every constant frame period in order to realize an editing function and a backward editing function of a reproduced picture. Further, the insertion of the refreshment frame can be achieved by providing the motion compensation prediction interframe coding system with the intraframe coding function.

Then, the intra-loop filtering portion **62** performs the two-dimensional lowpass filtering processing of a coding block of which the motion compensation prediction is effected by using the motion vector and further outputs a prediction signal **63**. Subsequently, the prediction error evaluating portion **64** evaluates the difference between the input television signal **52** and the prediction signal **63** of the coding block and outputs a prediction error signal **53** representing the evaluated difference.

Thereafter, in case where the coding method selection signal **61** indicates that the intraframe coding method is selected, the switching portion **66** selects the input television signal **52** as a signal **67** to be transformed by performing the orthogonal transform. In contrast, in case where the coding method selection signal **61** indicates that the interframe coding method is selected, the switching portion **66** selects the prediction error **65** as a signal **67**.

Further, the orthogonal transform portion **68** performs the orthogonal transform of the signal **67** to remove therefrom effects of the high-degree correlation between each pair of the neighbors of a pixel corresponding to the signal **67** and further outputs orthogonal transform coefficients **69**. At that time, a discrete cosine transform (DCT), which has a high efficiency of transform and of which firmware may be realized, is usually employed as the orthogonal transform.

Then, the quantization portion **70** quantizes the prediction error orthogonal transform coefficients **69** and outputs orthogonal transform quantization coefficients **72**.

The quantization step-size computing portion **73** calculates the quantization step size **71** from an amount **75** of codes remained in the code memory **74** in accordance with a method as will be described below.

The method of calculating the quantization step size **71** used in this prior art system will be described in detail hereinbelow.

In this prior art system, a picture represented by the input television signal is composed of 352 columns and 288 rows (i.e., 352 pixels in each row and 288 lines in the vertical direction) and is divided into blocks each of which is referred to as a Macro Block and is composed of 16 columns and 16 rows (i.e., 16 pixels in each row and 16 lines in the vertical direction), as illustrated in FIG. 2. The quantization step size Q_b is calculated from the following equation (1) at regular intervals on n Macro Blocks (n is a predetermined positive integer) when the quantization is effected.

$$Q_b = 2 \times \text{INT}[B + 200q] + 2 \quad (1)$$

where (a) $\text{INT}[*]$ is defined as a function of rounding a part after the decimal point of an argument $*$ down (e.g., INT

$[1.5]=1$, $\text{INT}[1.3]=1$, $\text{INT}[1.6]=1$), (b) B_{cont} represents the amount of the code remained in the code memory portion **74** and (c) q represents a coding rate parameter defined by the equation (2) using the coding rate V :

$$V = q \times 64K \text{ bits/second} \quad (2)$$

(e.g., $q=1$ if $V=64K$ bits/second).

As is apparent from the equation (1), when the amount of the remained code B_{cont} increases, the quantization step size Q_b also increases so as to limit an amount of generated codes and achieve the coding of video signals at a constant frame rate. For instance, if the amount of the remained code $B_{\text{cont}}=700$ bits, the quantization step size $Q_b=8$. Further, if the amount of the remained code $B_{\text{cont}}=6100$ bits, the quantization step size $Q_b=62$. Incidentally, the quantization is performed by using a predetermined quantization step size Q_b with respect to a first Macro Block to a $(n-1)$ th Macro Block. For example, the Q_b is set to be 32 in case where $V=64K$ bits/sec. and $q=1$.

In this prior art system, the value of n representing an interval of the calculations of the quantization step size is set to be 12.

The inverse orthogonal transform portion **76** performs the inverse orthogonal transform of the orthogonal transform quantization coefficients **72** and outputs a quantization-error-containing orthogonal transform signal **77** representing the result of the inverse orthogonal transform.

Further, the switching portion **66** selects a numerical-value-zero signal **80** as a reproduced picture calculating signal **79** in case where the coding method selection signal **61** selects the intraframe coding method. In contrast, the switching portion **66** selects the prediction signal **63** as the reproduced picture calculating signal **79** in case where the coding method selection signal **61** selects the interframe coding method.

Then, the reproduced picture calculating portion **78** adds the reproduced picture calculating signal **79** and the quantization-error-containing orthogonal transform signal **77** and outputs a reproduced picture signal **81** representing a reproduced picture of the coding block. Further, the picture memory **44** stores the reproduced picture signal **81** of the current frame and outputs the reproduced television signal (hereunder sometimes referred to as the reproduced picture signal) **55** of the previous frame. Moreover, the prediction error coding portion **82** performs the coding of the orthogonal transform quantization coefficients **72**, a signal indicating the quantization step size **71** and the coding method selection signal **61** and outputs a prediction error code **83**. Incidentally, the coding of the quantization step size **71** is performed only when the quantization step size **71** changes, namely, is performed only once every n Macro Blocks.

Furthermore, the motion vector coding portion **84** performs the coding of the motion vector signal **56** and calculates a motion vector code **85**. Thereafter, the multiplexer portion **86** calculates a transmission frame **87**, which has a predetermined format, from the prediction error code **83** and the motion vector **85**. Subsequently, the code memory portion **74** stores the transmission frame **87** once and further outputs the transmission frame **87** from the output terminal **89** in synchronization with a clock signal, which is inputted from an external circuit (not shown), as a transmission code **88**. Simultaneously, the code memory portion **74** calculates an amount of codes remained therein and outputs a signal indicating the calculated amount of the remained codes.

However, in this prior art system constructed as above described, the quantization step size Q_b is fixed during an

interval of blocks (n blocks (i.e., n Marco Blocks) in case of this prior art system) at which the calculation of the quantization step size is calculated.

That is, prediction errors are quantized by using the same quantization step size Q_b during the continuous n blocks independently of characteristics of the input television signals. More particularly, during the interval at which the calculation of the quantization is calculated, of the continuous blocks, a block having a fine pattern or texture and another block having a coarse pattern are quantized by using the same quantization step size Q_b . Thus, the prior art system has a first drawback that the picture quality of the block having a fine pattern is degraded, namely, what is called a "block distortion", which is a phenomenon that the block loses the fineness of the pattern thereof and comes to have a flat pattern, occurs due to the quantization of a prediction error generated from the block having a fine pattern and is visually perceived as degradation in picture quality.

Further, similarly, the quantized orthogonal transform coefficients are quantized by using the same quantization step size Q_b during the continuous n blocks independently of characteristics of the input television signals. That is during the interval at which the calculation of the quantization is calculated, of the continuous blocks, a block having a fine pattern, which should be coded by using the interframe coding method, and another block having a coarse pattern are quantized by using the same quantization step size Q_b . Thus, the prior art system has another similar drawback (hereunder referred to as a second drawback) that the picture quality of the block, which should be coded by the interframe coding method, having a fine pattern is degraded, namely, the "block distortion" occurs due to the quantization of orthogonal transform coefficients generated from the block having a fine pattern and is visually perceived as degradation in picture quality.

On the other hand, in order to reduce the amount of the codes generated by coding the quantization step size, the number of the continuous blocks quantized by using the same quantization step size needs to be more than a predetermined number, which is n in case of the above described prior art system. Thus, practically, it is not possible that the quantization step size is calculated or changed every block. The present invention is created to obviate the above described drawbacks of the prior art system.

SUMMARY OF THE INVENTION

It is therefore a first object of the present invention to eliminate the first drawback of the prior art system, namely, to provide a motion compensated prediction interframe coding system which can improve the picture quality by calculating a second quantization step size for each block from a reference (i.e., a first quantization step size), which is calculated from an amount of generated codes as proportional to the visual fineness of each of the continuous blocks to be quantized by using the first quantization step size, and further quantizing the prediction error signals by using the second quantization step size, namely, by employing a second quantization step size, which is smaller than the first quantization step size, for the quantization of a block having a fine pattern to limit the amount of the generated codes and maintain the fineness of the block and to thereby improve the picture quality of the block having a fine pattern, as well as the picture quality of an entire picture.

To achieve the foregoing first object and in accordance with a first aspect of the present invention, there is provided a motion compensated prediction interframe coding system which comprises an analog-to-digital conversion means for

performing an analog-to-digital conversion of a television signal, a block dividing means for dividing a predetermined area of the television signal digitalized by the analog-to-digital conversion means into blocks each having a predetermined size, a motion vector calculating means for calculating a motion vector, which represents a motion of a television picture represented by the television signal, of each block and for judging with respect to each whether or not the motion compensation is performed by using by the motion vector, a motion compensation means for performing a motion compensation of a reproduced picture signal of a previous frame with respect to each block of which the motion compensation is determined by the motion vector calculating means to be effected and for calculating predicted gray levels of pixels of each block of which the motion compensation is effected, a prediction error evaluating means for computing the difference between the gray level of each pixel of a coding block of the television picture and the predicted gray level thereof as a prediction error thereof, an orthogonal transform means for performing an orthogonal transform of the prediction error of each pixel of a coding block of the television picture so as to obtain orthogonal transform coefficients;

a first quantization step-size computing means for computing a first step size for the quantization from an amount of generated codes, a variance calculating means for calculating a variance of the gray levels of the pixels of each block of input television signal, a second quantization step-size computing means for classifies the blocks into a predetermined number of classes according to the variance and computing a second step size for the quantization of each block from the first step size, a quantization means for quantizing coefficients of an orthogonal transform by using the second step size to obtain quantized coefficients of orthogonal transform, an orthogonal transform coefficient coding means for performing the coding of the prediction error, the first step size and information on the classes and the quantized coefficients of the orthogonal transform, a quantized prediction error calculating means for effecting an inverse orthogonal transform of the quantized coefficients of the orthogonal transform to obtain quantized prediction errors, a reproduced picture calculating means for calculating a reproduced picture from the quantized prediction errors and the predicted gray levels of the pixels of the blocks, a memory portion for storing the reproduced picture and a motion vector coding means for performing the coding of the motion vectors.

Incidentally, the fineness of the pattern of a block of the input television signal is considered as can be represented by a variance σ^2 of gray levels or brightness of pixels contained in the block. Therefore, for example, the variance σ^2 of gray levels of pixels of a block having a fine pattern is considered as smaller than that of gray levels of pixels of a block having a coarse pattern in which the gray level radically changes among pixels. Further, it can be considered that the higher the fineness of the pattern of a block, the smaller the variance of the gray levels of the pixels of the block becomes.

Thus, the motion compensated prediction interframe coding system according to the first aspect of the present invention can limit the amount of the generated codes and improve the picture quality of a block having a fine pattern by measuring the fineness of patterns of blocks of the input television signal in terms of the variance σ^2 of the gray level and quantizing the prediction error signals by use of a second quantizing step size, which is obtained by multiplying the first quantization step size a value proportional to the fineness of patterns of blocks in such a manner to be smaller

than the first quantization step size, for the quantization of a block, which has a fine pattern, other than blocks to be quantized by using the first quantization step size among the continuous blocks.

Further, it is a second object of the present invention to eliminate the second drawback of the prior art system, namely, to provide a motion compensated prediction interframe coding system which can improve the picture quality by calculating a second quantization step size for blocks to be coded by using the intraframe coding method from a reference (i.e., a first quantization step size), which is calculated from an amount of generated codes as proportional to the visual fineness of the blocks to be coded by using the intraframe coding method and further quantizing the orthogonal transform coefficients by using the second quantization step size, namely, by employing a second quantization step size, which is smaller than the first quantization step size, for the quantization of a block having a fine pattern to limit the amount of the generated codes and maintain the fineness of the block and to thereby improve the picture of the block having a fine pattern, as well as the picture quality of an entire picture.

To achieve the foregoing second object and in accordance with a second aspect of the present invention, there is provided a motion compensated prediction interframe coding system which comprises an analog-to-digital conversion means for performing an analog-to-digital conversion of a television signal, a block dividing means for dividing a predetermined area of the television signal digitalized by the analog-to-digital conversion means into blocks each having a predetermined size, a motion vector calculating means for calculating a motion vector, which represents a motion of a television picture represented by the television signal, of each block and for judging with respect to each block whether or not the motion compensation is performed by using by the motion vector, a motion compensation means for performing a motion compensation of a reproduced picture signal of a previous frame with respect to each block of which the motion compensation is determined by the motion vector calculating means to be effected and for calculating predicted gray levels of pixels of each block of which the motion compensation is effected, a prediction error evaluating means for computing the difference between the gray level of each pixel of a coding block of the television picture and the predicted gray level thereof as a prediction error thereof, a coding method selection means for selecting a method of coding of a block from an interframe coding and interframe coding methods, a first switch means for selecting a signal, of which an orthogonal transform is effected, in accordance with the selection made by the coding method selecting means from the gray levels of pixels of blocks represented by the television signal and the prediction errors, an orthogonal transform means for performing an orthogonal transform of the prediction error or the gray levels selected by the first switch means, a first quantization step-size computing means for computing a first step size for the quantization from an amount of generated codes, a variance calculating means for calculating a variance of the gray levels of the pixels of each block of input television signal, a second quantization step-size computing means for classifying the blocks into a predetermined number of classes according to the variance and computing a second step size for the quantization of each block from the first step size in case of the blocks to be coded by using an intra-frame coding method and for treating the first step sizes as the second step sizes in case of the blocks to be coded by using an interframe coding method, a

quantized transform coefficient calculating means for quantizing coefficients of an orthogonal transform by using the second step size to obtain quantized coefficients of an orthogonal transform, an orthogonal transform coefficient coding means for performing information on the selection of the coding methods, the coding of the prediction error, the first step size and information on the classes and the quantized coefficients of the orthogonal transform, an inverse quantization means for effecting an inverse orthogonal transform of the quantized coefficients of the orthogonal transform to obtain inversely-quantized values, a second switch means for selecting a numerical value of zero as a gray level of a pixels of a reproduced picture in case where the coding method selection means selects the intraframe coding method and in contrast, selects the predicted value as the gray level of a pixel of the reproduced picture in case where the coding method selection means selects the interframe coding method, a reproduced picture calculating means for calculating a reproduced picture from the inversely-quantized values and the numerical value of zero or from the predicted gray levels of the pixels of the blocks, a memory portion for storing the reproduced picture and a motion vector coding means for performing the coding of the motion vectors.

As above described, the fineness of the pattern of a block of the input television signal is considered as can be represented by a variance σ^2 of gray levels or brightness of pixels contained in the block.

Therefore, the motion compensated prediction interframe coding system according to the second aspect of the present invention can limit the amount of the generated codes and improve the picture quality of a block, which should be coded by using the intraframe coding method and has a fine pattern, by measuring the fineness of patterns of blocks of the input television signal in terms of the variance σ^2 of the gray level and quantizing the orthogonal transform coefficients by use of a second quantization step size, which is obtained by multiplying the first quantization step size a value proportional to the fineness of patterns of blocks in such a manner to be smaller than the first quantization step size, for the quantization of a block, which should be code by the using intraframe coding method and has a fine pattern, other than blocks to be quantized by using the first quantization step size among the continuous blocks.

Moreover, it is a third object of the present invention to eliminate the second drawback of the prior art system, namely, to provide a motion compensated prediction interframe coding system which can maintain the fineness of an original picture and thereby improve the picture quality of the reproduced picture.

To achieve the foregoing third object and in accordance with a third aspect of the present invention, there is provided a motion compensated prediction interframe coding system which comprises an analog-to-digital conversion means for performing an analog-to-digital conversion of a television signal, a block dividing means for dividing a predetermined area of the television signal digitalized by the analog-to-digital conversion means into blocks each having a predetermined size, a motion vector calculating means for calculating a motion vector, which represents a motion of a television picture represented by the television signal, of each block and for judging with respect to each block whether or not a motion compensation prediction is performed by using by the motion vector, a motion compensation predicting means for performing a motion compensation prediction of a reproduced picture signal of a previous frame with respect to each block of which the motion

compensation prediction is determined by the motion vector calculating means to be effected and for calculating predicted gray levels of pixels of each block of which the motion compensation prediction is effected, a prediction error evaluating means for computing the difference between the gray level of each pixel of a coding block of the television picture and the predicted gray level thereof as a prediction error thereof, a coding method selection means for selecting a method of coding of a block from an interframe coding and interframe coding methods, a first switch means for selecting a signal, of which an orthogonal transform is effected, in accordance with the selection made by the coding method selecting means from the gray levels of pixels of blocks represented by the television signal and the prediction errors, an orthogonal transform means for performing an orthogonal transform of the prediction error or the gray levels selected by the first switch means, a first quantization step-size computing means for computing a first step size for the quantization from an amount of generated codes, an average and variance calculating means for calculating an averaged value and a variance of the gray levels of the pixels of each block of input television signal, a second quantization step-size computing means for classifying the blocks into a predetermined number of classes according to the averaged value and variance and computing a second step size for the quantization of each block from the first step size in case of the blocks to be coded by using an intra-frame coding method and for treating the first step sizes as the second step sizes in case of the blocks to be coded by using an interframe coding method, a quantized transform coefficient calculating means for quantizing coefficients of an orthogonal transform by using the second step size to obtain quantized coefficients of an orthogonal transform, an orthogonal transform coefficient coding means for performing information on the selection of the coding methods, the coding of the prediction error, the first step size and information on the classes and the quantized coefficients of the orthogonal transform, an inverse quantization means for effecting an inverse orthogonal transform of the quantized coefficients of the orthogonal transform to obtain inversely-quantized values, a second switch means for selecting a numerical value of zero or the predicted gray level obtained by the motion compensation prediction as a gray level of a pixels of a reproduced picture according to the selection made by the coding method selection means, a reproduced picture calculating means for calculating a reproduced picture from the inversely-quantized values and the numerical value of zero or from the predicted gray levels of the pixels of the blocks, a memory portion for storing the reproduced picture and a motion vector coding means for performing the coding of the motion vectors.

As stated above, the fineness of the pattern of a block of the input television signal is considered as can be represented by a variance σ^2 of gray levels of pixels contained in the block.

Further, in case where the averaged value of the the gray levels of pixels of a block is a certain value, this block may not visually be striking even if the variance of the gray levels of the pixels of this block is small and the fineness of the pattern of this block is high.

Therefore, the motion compensated prediction interframe coding system according to the second aspect of the present invention can limit the amount of the generated codes and improve the picture quality of a block, which should be coded by using the intraframe coding method and has a fine pattern and of which the averaged value of gray levels of pixels is greater or equal to a predetermined value, by

measuring the fineness of a pattern of each block of the input television signal in terms of the variance σ^2 of the gray level and quantizing the orthogonal transform coefficients by use of a second quantization step size, which is obtained by multiplying the first quantization step size a value proportional to the fineness of patterns of blocks in such a manner to be smaller than the first quantization step size, for the quantization of a block, which should be code by the using intraframe coding method and has a fine pattern, other than blocks to be quantized by using the first quantization step size among the continuous blocks.

Furthermore, it is a fourth object of the present invention to eliminate the second drawback of the prior art system, namely, to provide a motion compensated prediction interframe coding system which can improve the picture quality by calculating a second quantization step size for each block (hereunder sometimes referred to as luminance signal block), which is to be coded by using the intraframe coding method and respectively corresponds to a part of a luminance signal and of which the averaged value of the gray levels of corresponding pixels is equal to or more than a predetermined value, from a reference (i.e., a first quantization step size), which is calculated from an amount of generated codes as proportional to the visual fineness of the blocks to be coded by using the intraframe coding method and further quantizing the orthogonal transform coefficients by using the second quantization step size, namely, by employing a second quantization step size, which is smaller than the first quantization step size, for the quantization of a luminance signal block, of which the averaged value of gray levels of corresponding pixels is equal to or more than a predetermined value and the fineness is high, to limit the amount of the generated codes, to maintain the fineness of the original picture and to thereby improve the picture quality of the blocks, and which can prevent discoloration of a coding block, which is due to the fact that an amount of codes corresponding to a color difference signal is extremely small, by reducing the amount of codes corresponding to the luminance signal and increase an amount of codes corresponding to the color difference signal by modifying a threshold value for evaluating the second quantization step size when the first quantization step size is equal to or more than a predetermined value, thereby improving the picture quality of the entire reproduced picture.

To achieve the foregoing fourth object and in accordance with a fourth aspect of the present invention, there is provided a motion compensated prediction interframe coding system which comprises an analog-to-digital conversion means for performing an analog-to-digital conversion of a television signal, a block dividing means for dividing a predetermined area of the television signal digitalized by the analog-to-digital conversion means into blocks each having a predetermined size, a motion vector calculating means for calculating a motion vector, which represents a motion of a television picture represented by the television signal, of each block and for judging with respect to each block whether or not a motion compensation prediction is performed by using by the motion vector, a motion compensation predicting means for performing a motion compensation prediction of a reproduced picture signal of a previous frame with respect to each block of which the motion compensation prediction is determined by the motion vector calculating means to be effected and for calculating predicted gray levels of pixels of each block of which the motion compensation prediction is effected, a prediction error evaluating means for computing the difference between the gray level of each pixel of a coding block of the

television picture and the predicted gray level thereof as a prediction error thereof, a coding method selection means for selecting a method of coding of a block from an interframe coding and interframe coding methods, a first switch means for selecting a signal, of which an orthogonal transform is effected, in accordance with the selection made by the coding method selecting means from the gray levels of pixels of blocks represented by the television signal and the prediction errors, an orthogonal transform means for performing an orthogonal transform of the prediction error or the gray levels selected by the first switch means; a first quantization step-size computing means for computing a first step size for the quantization from an amount of generated codes, an average and variance calculating means for calculating an averaged value and a variance of the gray levels of the pixels of each block of input television signal, a threshold value modifying means for modifying predetermined threshold values according to the first step size to classify blocks, which are represented by luminance signals and are to be coded by effecting the intraframe coding method, into a predetermined number of classes, a second quantization step-size computing means for classifying the blocks, which are represented by luminance signals and are to be coded by effecting the intraframe coding method, into the predetermined number of classes according to the averaged value and variance and computing a second step size for the quantization of each block from the first step size in case of the blocks to be coded by using an intraframe coding method and for treating the first step sizes as the second step sizes in case of the blocks to be coded by using an interframe coding method, a quantized transform coefficient calculating means for quantizing coefficients of an orthogonal transform by using the second step size to obtain quantized coefficients of an orthogonal transform, an orthogonal transform coefficient coding means for performing information on the selection of the coding methods, the coding of the prediction error, the first step size and information on the classes and the quantized coefficients of the orthogonal transform, an inverse quantization means for effecting an inverse orthogonal transform of the quantized coefficients of the orthogonal transform to obtain inversely-quantized values, a second switch means for selecting a numerical value of zero, or the predicted gray level obtained by the motion compensation prediction as a gray level of a pixels of a reproduced picture according to the selection made by the coding method selection means, a reproduced picture calculating means for calculating a reproduced picture from the inversely-quantized values and the numerical value of zero or from the predicted gray levels of the pixels of the blocks, a memory portion for storing the reproduced picture; and a motion vector coding means for performing the coding of the motion vectors.

As above-mentioned, the fineness of the pattern of a block of the input television signal is considered as can be represented by a variance σ^2 of gray levels of pixels contained in the block. Further, in case where the averaged value of the gray levels of pixels of a block is a certain value, this block may not visually be striking even if the variance of the gray levels of the pixels of this block is small and the fineness of the pattern of this block is high.

Thus, the motion compensated prediction interframe coding system according to the fourth aspect of the present invention can limit the amount of the generated codes and improve the picture of a block, which should be coded by using the intraframe coding method and has a fine pattern and of which the averaged value of gray levels of pixels is greater or equal to a predetermined value, by measuring the

fineness of a pattern of each block of the luminance signal contained in the input television signal in terms of the variance σ^2 of the gray level and quantizing the orthogonal transform coefficients by use of a second quantization step size, which is obtained by multiplying the first quantization step size a value proportional to the fineness of patterns of blocks according to a threshold value modified on the basis of the averaged value of the pixels of the blocks, the variance of the gray level and the first quantization step size in such a manner to be smaller than the first quantization step size, for the quantization of a block, which should be code by the using intraframe coding method and has a fine pattern, other than blocks to be quantized by using the first quantization step size among the continuous blocks.

BRIEF DESCRIPTION OF THE DRAWINGS

Other features, objects and advantages of the present invention will become apparent from the following description of preferred embodiments with reference to the drawings in which like reference characters designate like or corresponding parts throughout several views, and in which:

FIG. 1 is a schematic block diagram for showing a prior art motion compensated prediction interframe coding system;

FIG. 2 is a diagram for illustrating the relation between a picture represented by an input television signal and a Macro Block;

FIG. 3 is a schematic block diagram for showing a first motion compensated prediction interframe coding system embodying the present invention;

FIG. 4 is a schematic block diagram for showing a second motion compensated prediction interframe coding system embodying the present invention;

FIG. 5 is a schematic block diagram for showing a third motion compensated prediction interframe coding system embodying the present invention;

FIG. 6 is a schematic block diagram for showing a fourth motion compensated prediction interframe coding system embodying the present invention; and

FIG. 7 is a diagram for illustrating the relation between the quantization step sizes and threshold values.

BRIEF DESCRIPTION OF THE PREFERRED EMBODIMENTS

Hereinafter, the preferred embodiments of the present invention will be described in detail by referring to the accompanying drawings.

First, a first embodiment of the present invention will be described hereinbelow with reference to FIG. 3.

In this figure, reference numeral **101** designates an input terminal from which television signals are inputted to the system; **103** a motion vector calculating portion for comparing a picture signal of a coding block of a current frame with a reproduced picture signal of a previous frame and calculating a motion vector; **104** a picture memory portion for storing reproduced picture signals of a current and previous frames; **107** a motion compensation portion for performing a motion compensation of the reproduced picture signals of the previous frame; **109** an intra-loop filter portion for performing two-dimensional lowpass filtering processing of a motion compensation predicting signal; **111** a prediction error evaluating portion for evaluating a prediction error by computing the difference between an original picture signal and a predictive signal of a coding block; **113** an orthogonal transform portion for performing an

orthogonal transform of the prediction error signal ; **115** a quantization portion for quantizing coefficients of an orthogonal transform; **116** a variance calculating portion for calculating a variance of the input television signal; **118** a second quantization step-size computing portion for computing a second step size for the quantization; **122** a first quantization step-size computing portion for computing a first step size for the quantization; **123** a code memory portion for temporarily storing a transmission frame; **126** an inverse orthogonal transform portion for effecting an inverse orthogonal transform of the quantized orthogonal transform coefficients; **128** a reproduced picture calculating portion for calculating a reproduced picture of a current frame; **130** a prediction error coding portion for performing what is called "transmitting channel coding" of a prediction error, the first quantization step size and quantization class information; **132** a motion vector coding portion for performing the transmitting channel coding of a motion vector; **134** a multiplexer portion for computing a transmitting frame on the basis of the prediction code and the coded motion vector (hereunder sometimes referred to as the motion vector code); and **137** an output terminal from which a transmission signal is output.

Hereinafter, an operation of this motion compensated prediction interframe coding system having the above described arrangement will be described.

First, television signals are converted into digital television signals by an analog-to-digital (A/D) conversion circuit (not shown). Then, pixels represented by the digital television signals are divided into blocks each of which is a rectangular array composed of $M \times N$ pixels arranged in M columns and N rows. Further, the digital television signals are input to the system from the input terminal **101** as input television signals **102**. Then, the motion vector calculating portion **103** compares the input television signal **102** with a reproduced picture signal **105** of a previous frame stored in the picture memory portion **104** and calculating the motion of a coding block as a motion vector and moreover outputs a motion vector signal **106** representing the motion vector. Simultaneously, the motion vector calculating portion **103** judges from the result of the evaluation of the motion vector whether the motion compensation made with respect to the coding block is effective or ineffective. Further, the motion vector calculating portion **103** outputs motion compensation control information signal which represents the result of the judgement and is superposed on the motion vector signal **106**.

A motion compensation portion **107** performs a motion compensation of the reproduced television signal **105** of a previous frame corresponding to the coding block in case where the motion compensation control information signal indicates that the motion compensation is effective (i.e., the motion compensation is effected by using the motion vector signal) and outputs the reproduced television signal without change as a motion compensation signal **108** in case where the motion compensation control information signal indicates that the motion compensation prediction is ineffective (i.e., the motion compensation should not be effected).

Then, the intra-loop filtering portion **109** performs the two dimensional lowpass filtering processing of a coding block of which the motion compensation is effected by using the motion vector and further outputs a prediction signal **110**.

Subsequently, the prediction error evaluating portion **111** evaluates the difference between the input television signal **102** and the prediction signal **110** of the coding block and outputs a prediction error signal **112** representing the evalu-

ated difference. Further, the orthogonal transform portion **113** performs the orthogonal transform of the signal **112** to remove therefrom effects of the high-degree correlation between each pair of the neighbors of a pixel corresponding to the signal **112** and further outputs a prediction error orthogonal transform coefficient signal **114** representing prediction error orthogonal transform coefficients. At that time, the discrete cosine transform (DCT), which has a high efficiency of transform and of which firmware may be realized as described above, is usually employed as the orthogonal transform.

Hereunder, will be described a method for calculating the second quantization step size **120** which is used to quantize the prediction error orthogonal transform coefficients **114**.

The variance calculating portion **116** calculates a variance σ^2 of the input television signal of the coding block from the following equation (3) and outputs a variance signal **117** representing the calculated variance. Further, the variance σ^2 is small in case where the fineness of a block represented by the input television signal **102** is high, while the variance σ^2 is large in case where the fineness of a block represented by the input television signal **102** is low.

$$\sigma^2 = (1/(M \times N)) \sum_{i=1}^M \sum_{j=1}^N (p(i, j) - P)^2 \quad (3)$$

where M represents the number of columns (or pixels on a row) of a block; N the number of rows of the block; $p(i, j)$ a gray level of a pixel at an address (i, j) in the block; and P the averaged value of the gray levels of the pixels of the block (see the following equation (4)).

$$P = (1/(M \times N)) \sum_{i=1}^M \sum_{j=1}^N p(i, j) \quad (4)$$

Further, the second quantization step size calculating portion **118** generates a second quantization step size signal **120** representing second quantization step size and a quantization class information signal **121** representing the quantization class information. The first quantization step size calculating portion **122** obtains the first quantization step size from an amount of codes remained in the code memory portion **123** by using the above described method, which is employed for calculating the quantization step size in the prior art system, and outputs a first quantization step size signal **119** representing the first quantization step size.

As will be described below, the second quantization step size calculating portion **118** compares the variance represented by the variance signal **117** with each of three threshold values $th1$, $th2$ and $th3$ to divide each block into four quantization classes. Further, the second quantization step size represented by the second quantization step size signal **120** for each block obtained from the first quantization step size represented by the first quantization step size signal **119**. Incidentally, let Qb denote the first quantization step size; and $Qstep$ the second quantization step size.

- ① In case where $0 \leq \sigma^2 < th1$, the class No. (Qstep Class)=1 and $Qstep = (1/4)Qb$;
- ② In case where $th1 \leq \sigma^2 < th2$, Qstep Class=2 and $Qstep = (2/4)Qb$;
- ③ In case where $th2 \leq \sigma^2 < th3$, Qstep Class=3 and $Qstep = (3/4)Qb$; and
- ④ In case where $th3 \leq \sigma^2$, Qstep Class=4 and $Qstep = Qb$.

Thereby, for a block having a fine pattern or texture, the second quantization step size is made to become smaller than the first quantization step size.

Then, the quantization portion **115** quantizes the prediction error orthogonal transform coefficients **114** by using the second quantization step size **120** to obtain orthogonal transform quantization coefficients and outputs an orthogonal transform quantization coefficient signal **125** representing the orthogonal transform quantization coefficients. Further, the inverse orthogonal transform portion **126** performs the inverse orthogonal transform of the prediction error orthogonal transform quantization coefficients **125** and outputs a quantization-error-containing prediction error signal **127** representing the result of the inverse orthogonal transform.

Subsequently, the reproduced picture calculating portion **128** adds the prediction signal **110** and the quantization-error-containing prediction error signal **127** and outputs a reproduced picture signal **129** representing a reproduced picture of the coding block. Further, the picture memory **44** stores the reproduced picture signal **129** of the current frame and outputs the reproduced picture signal **105** of the previous frame. Moreover, the prediction error coding portion **130** performs the coding of the prediction error orthogonal transform quantization coefficients **125**, a signal indicating the first quantization step size **119** and the quantization class information **121** and outputs a prediction error code signal **131** representing the prediction error code. Furthermore, the motion vector coding portion **132** performs the coding of the motion vector signal **106** and calculates a motion vector code and a motion vector code signal **133** representing the motion vector code. Thereafter, the multiplexer portion **134** calculates a transmission frame **135**, which has a predetermined format, from the prediction error code **131** and the motion vector code **133**. Subsequently, the code memory portion **123** stores the transmission frame once and further outputs a transmission frame signal **135** representing the transmission frame from the output terminal **137** in synchronization with a clock signal, which is inputted from an external circuit (not shown), as a transmission code represented by a transmission code signal **136**. Simultaneously, the code memory portion **123** calculates an amount of codes remained therein and outputs a remained amount code signal **124** indicating the calculated amount of the remained codes.

As is apparent from the foregoing description, this embodiment calculates the second quantization step size from the first quantization step size as proportional to the fineness of the pattern of each block among a group of continuous blocks, each of which is quantized by using a quantization step size, and quantizes the prediction error of a block having a fine pattern by using the the second quantization step size. Thereby, the picture quality of the reproduced picture can be improved without degrading the fineness of the pattern or texture of the entire picture.

Incidentally, the variance **117** calculated by the variance calculating portion **116** is defined by the equation (3). However, any other kind of a measure may be employed as the variance so long as it can be used to measure the fineness of a picture represented by the input television signal **102**. For instance, the following measure D defined by an equation (5) may be employed because the size of a block is generally fixed (namely, the number of pixels on a row is M and that of rows is N) and the calculation thereof can be easily effected.

$$D = (1/(M \times N)) \sum_{i=1}^M \sum_{j=1}^N |p(i, j) - P| \quad (5)$$

where $p(i, j)$ denotes a gray level of a pixel at an address (i, j) in the block; and P the averaged value of the gray levels of the pixels of the block.

Further, in this embodiment, the number of the classes is four as above described. However, a different number may be employed as the number of the classes.

Additionally, in this embodiment, the second quantization step size Q_{step} is determined for each class as described in ①~④. Another method for determining the second quantization step size may employed as long as the second quantization step size can be determined by the method to be small for a block having a small variance.

As described above, this embodiment first measures characteristics regarding the fineness of a pattern or texture of each block of picture, which is represented by an input television signal and is divided into a group of continuous blocks each quantized by using a quantization step size, and changes the quantization step size into a smaller one if quantizes a block having a picture pattern or texture finer than patterns of the other blocks. Thereby, an amount of generated codes can be limited but a motion compensated prediction frame coding operation can be performed without degrading the fineness of the texture of the original input picture. Further, the picture quality of the reproduced picture can be improved. Thus, practically, the present invention is very efficacious.

Next, a second embodiment of the present invention will be described hereinbelow with reference to FIG. 4.

In this figure, reference numeral **201** designates an input terminal from which television signals are inputted to the system; **203** a motion vector calculating portion for comparing a picture signal of a coding block of a current frame with a reproduced picture signal of a previous frame and calculating a motion vector; **204** a picture memory portion for storing reproduced picture signals of a current and previous frames; **207** a motion compensation portion for performing a motion compensation of the reproduced picture signals of the previous frame; **209** a coding method selection portion for selecting a method of coding of a block from an interframe coding and interframe coding methods; **211** an intra-loop filter portion for performing two-dimensional lowpass filtering processing of a motion compensation signal; **213** a prediction error evaluating portion for evaluating a prediction error by computing the difference between an original picture signal and a predictive signal of a coding block; **215** a switch portion for selecting a signal, of which an orthogonal transform is effected, in accordance with a coding method selecting signal and further selecting a signal from which a reproduced picture is calculated; **217** an orthogonal transform portion for performing an orthogonal transform of the prediction error signal; **219** a quantization portion for quantizing coefficients of an orthogonal transform; **221** a second quantization step-size computing portion for computing a second step size for the quantization; **222** a first quantization step-size computing portion for computing a first step size for the quantization; **225** a variance calculating portion for calculating a variance of the input television signal; **228** a code memory portion for temporarily storing a transmission frame; **230** an inverse orthogonal transform portion for effecting an inverse orthogonal transform of the quantized orthogonal transform coefficients; **234** a reproduced picture calculating portion for calculating a reproduced picture of a current frame; **236** a prediction error coding portion for performing what is called "transmitting channel coding" of a coding method selection signal, a prediction error, the first quantization step size and quantization class information; **238** a motion vector coding portion for performing the transmitting channel coding of a motion vector; **240** a multiplexer portion for computing a transmitting frame on the basis of the prediction code and

the motion vector code; and **243** an output terminal from which a transmission signal is output.

Hereinafter, an operation of this motion compensated prediction interframe coding system having the above described arrangement will be described.

First, television signals are converted into digital television signals by an A/D conversion circuit (not shown). Then, pixels represented by the digital television signals are divided into blocks each of which is a rectangular array composed of $M \times N$ pixels arranged in M columns and N rows. Further, the digital television signals are input to the system from the input terminal **201** as input television signals **202**. Then, the motion vector calculating portion **203** compares the input television signal **202** with a reproduced picture signal **205** of a previous frame stored in the picture memory portion **204** and calculating the motion of a coding block as a motion vector and moreover outputs a motion vector signal **206** representing the motion vector. Simultaneously, the motion vector calculating portion **203** judges from the result of the evaluation of the motion vector whether the motion compensation made with respect to the coding block is effective or ineffective. Further, the motion vector calculating portion **203** outputs motion compensation control information signal which represents the result of the judgement and is superposed on the motion vector signal **206**.

A motion compensation portion **207** performs a motion compensation of the reproduced television signal **205** of a previous frame in case where the motion compensation control information indicates that the motion compensation is effective (i.e., the motion compensation is effected by using motion vector) and outputs the reproduced television signal without change as a motion compensation signal **208** in case where the motion compensation control information indicates that the motion compensation is ineffective (i.e., the motion compensation should not be effected).

The coding method selection portion **209** compares the input television signal **202** with the motion compensation signal **208** every block and judges whether or not the motion compensation prediction is effective. Further, the coding method selection portion **209** judges that an intraframe coding method is effective for a current block in question in case where the motion compensation prediction is effective and that an interframe coding method is effective for a current block in question in case where the motion compensation prediction is not effective, and outputs a coding method selection signal **210** representing the result of this judgement. Further, in case of a coding system in which it is necessary to insert a refreshment frame between other frames, the portion **209** selects the coding method selection signal **210** in such a manner to code all of the blocks by use of the intra-frame coding method by inserting a refreshment frame between other frames every constant frame period.

Then, the intra-loop filtering portion **211** performs the two-dimensional lowpass filtering processing of the motion compensation signal **208** in case where the motion compensation of a coding block is to be effected by using the motion vector and in another case, outputs the motion compensation signal **208** as a prediction signal **212** without effecting the intra-loop filtering processing.

Subsequently, the prediction error evaluating portion **213** evaluates the difference between the input television signal **202** and the prediction signal **212** of the coding block and outputs a prediction error signal **214** representing the evaluated difference.

Thereafter, in case where the coding method selection signal **210** indicates that the intraframe coding method is

selected, the switching portion **215** selects the input television **202** as a signal **216** to be transformed by performing the orthogonal transform. In contrast, in case where the coding method selection signal **210** indicates that the interframe coding method is selected, the switching portion **215** selects the prediction error signal **214** as a signal **216**.

Further, the orthogonal transform portion **217** performs the orthogonal transform of the signal **216** to remove therefrom effects of the high-degree correlation between each pair of the neighbors of a pixel corresponding to the signal **216** and further outputs an orthogonal transform coefficient signal **218** representing orthogonal transform coefficients. At that time, the DCT, which has a high efficiency of transform and of which firmware may be realized, is usually employed as the orthogonal transform.

Then, the quantization portion **219** quantizes the orthogonal transform coefficients represented by the signal **218** by using the second quantization step size. Hereinafter, a method of calculating the second quantization step size represented by a second quantization step size signal **220**.

(1) In case where a coding block is a block to be coded by the intraframe coding method:

The second quantization step size calculating portion **221** outputs the first quantization step size calculated by the first quantization step size calculating portion **222** from the amount of the remained code **223** by using the method described with reference to FIG. 1 as the second quantization step size.

(2) In case where a coding block is a block to be coded by the interframe coding method:

By effecting a process of steps (i) and (ii) as will be described later, a variance of gray levels of pixels of the coding block is first calculated. Then, the block is divided into classes according to the calculated variance. Further, the second quantization step size actually used in the quantization for each class is calculated from the first quantization step size.

(i) The variance calculating portion **225** calculates a variance σ^2 of the input television signal **202** of the coding block from the following equation (6) and outputs a variance signal **226** representing the calculated variance. Further, the variance σ^2 is small in case where the fineness of a block represented by the input television signal **202** is high, while the variance σ^2 is large in case where the fineness of a block represented by the input television signal **202** is low.

$$\sigma^2 = (1/(M \times N)) \sum_{i=1}^M \sum_{j=1}^N (p(i, j) - P)^2 \quad (6)$$

where M represents the number of columns (or pixels on a row) of a block; N the number of rows of the block; $p(i, j)$ a gray level of a pixel at an address (i, j) in the block; and P the averaged value of the gray levels of the pixels of the block (given by the following equation (7)).

$$P = (1/(M \times N)) \sum_{i=1}^M \sum_{j=1}^N p(i, j) \quad (7)$$

(ii) Further, the second quantization step size calculating portion **221** calculates a second quantization step size represented by a second quantization step size signal **220** and the quantization class information represented by a quantization class information signal **227** from the variance signal **226** (hereunder sometimes referred to as the coding block variance signal) corresponding to the coding block and the

first quantization step size signal **224**. Further, the first quantization step size represented by the signal **224** is obtained by the first quantization step size calculating portion **222** from the amount of the codes remained in the code memory **228** by using the method described with reference to FIG. 1.

The second quantization step size calculating portion **221** compares the variance represented by the variance signal **226** with each of three threshold values **th1**, **th2** and **th3** with respect to a block to be coded by using the interframe coding method and divides each block into four quantization classes. Further, the second quantization step size represented by the second quantization step size signal **220** for each block obtained from the first quantization step size represented by the first quantization step size signal **224**. Incidentally, let Q_b denote the first quantization step size; and Q_{step} the second quantization step size.

① In case where $0 \leq \sigma^2 < th1$, the class No. (Qstep Class)=1 and $Q_{step} = (1/4)Q_b$;

② In case where $th1 \leq \sigma^2 < th2$, Qstep Class=2 and $Q_{step} = (2/4)Q_b$;

③ In case where $th2 \leq \sigma^2 < th3$, Qstep Class=3 and $Q_{step} = (3/4)Q_b$; and

④ In case where $th3 \leq \sigma^2$, Qstep Class=4 and $Q_{step} = Q_b$.

Thereby, the second quantization step size used for quantizing a block to be coded by using the interframe coding method is made to become smaller than the first quantization step size.

Then, the quantization portion **219** quantizes the orthogonal transform coefficients **214** by using the second quantization step size **220** to obtain orthogonal transform quantization coefficients and outputs an orthogonal transform quantization coefficient signal **229** representing the orthogonal transform quantization coefficients. Further, the inverse orthogonal transform portion **230** performs the inverse orthogonal transform of the orthogonal transform quantization coefficients **229** and outputs a quantization-error-containing error signal **231** representing the result of the inverse orthogonal transform.

Further, another switching portion **251** selects a numerical-value-zero signal **233** as a reproduced picture calculated signal **232** in case where the coding method selection signal **210** selects the intraframe coding method. In contrast, the switching portion **216** selects the prediction signal **212** as the reproduced picture calculating signal **232** in case where the coding method selection signal **210** selects the interframe coding method.

Then, the reproduced picture calculating portion **234** adds the reproduced picture calculating signal **232** and the quantization-error-containing orthogonal transform signal **231** and outputs a reproduced picture signal **235** representing a reproduced picture of the coding block. Further, the picture memory **204** stores the reproduced picture signal **235** of the current frame and outputs the reproduced picture signal **205** of the previous frame.

Moreover, the prediction error coding portion **236** performs the coding of the orthogonal transform quantization coefficients represented by the signal **225**, a the first quantization step size represented by the signal **224**, the quantization class information represented by the signal **227** and the information represented by the coding method selection signal **210** and outputs a prediction error code **237**.

Furthermore, the motion vector coding portion **238** performs the coding of the motion vector signal **206** and calculates a motion vector code, which is represented by a motion vector code signal **239**.

Thereafter, the multiplexer portion **240** calculates a transmission frame **241**, which has a predetermined format, from the prediction error code **237** and the motion vector code **239**.

Subsequently, the code memory portion **228** stores the transmission frame **241** once and further outputs the transmission frame **241** from the output terminal **243** in synchronization with a clock signal, which is inputted from an external circuit (not shown), as a transmission code represented by a transmission code signal **242**. Simultaneously, the code memory portion **228** calculates an amount of codes remained therein and outputs a signal **223** indicating the calculated amount of the remained codes.

As is apparent from the foregoing description, this embodiment calculates the second quantization step size from the first quantization step size as proportional to the fineness of the pattern of each block among a group of continuous blocks, each of which is quantized by using a quantization step size, and quantizes the prediction error of a block having a fine pattern by using the the second quantization step size. Thereby, the picture quality of the entire reproduced picture can be improved without degrading the fineness of the pattern or texture of the picture.

Incidentally, the variance **226** calculated by the variance calculating portion **225** is defined by the equation (6). However, any other kind of a measure may be employed as the variance so long as it can be used to measure the fineness of a picture represented by the input television signal **102**. For example, the following measure D defined by an equation (8) may be employed because the size of a block is generally fixed (namely, the number of pixels on a row is M and that of rows is N) and the calculation thereof can be easily effected.

$$D = (1 / (M \times N)) \sum_{i=1}^M \sum_{j=1}^N |p(i, j) - P| \quad (8)$$

where $p(i, j)$ denotes a gray level of a pixel at an address (i, j) in the block; and P the averaged value of the gray levels of the pixels of the block.

Further, in this embodiment, the number of the classes is four, as above described. However, a different number may be employed as the number of the classes so long as the second quantization step size can be determined to be small for a block having a small variance.

As described above, this embodiment first measures characteristics regarding the fineness of a picture pattern or texture of each block of picture, which is represented by an input television signal and is divided into a group of continuous blocks each quantized by using a quantization step size, and changes the quantization step size into a smaller one when quantizing a block having a fine pattern or texture and to be coded by effecting the intra-frame coding method. Thereby, an amount of generated codes can be limited but a motion compensated prediction frame coding operation can be performed without degrading the fineness of the texture of the original input picture. Further, the picture quality of the reproduced picture can be improved. Therefore, practically, the present invention is very advantageous.

Next, a third embodiment of the present invention will be described hereinbelow with reference to FIG. 5.

In this figure, reference numeral **301** designates an input terminal from which television signals are inputted to the system; **303** a motion vector calculating portion for comparing a picture signal of a coding block of a current frame with a reproduced picture signal of a previous frame and calculating a motion vector; **304** a picture memory portion for storing reproduced picture signals of a current and previous frames; **307** a motion compensation predicting portion for performing a motion compensation predicting of

the reproduced picture signals of the previous frame; **309** a coding method selection portion for selecting a method of coding of a block from an interframe coding and intraframe coding methods; **311** an intra-loop filter portion for performing two-dimensional lowpass filtering processing of a motion compensation predicting signal; **313** a prediction error evaluating portion for evaluating a prediction error by computing the difference between an original picture signal and a predictive signal of a coding block; **315** a switch portion for selecting a signal, of which an orthogonal transform is effected, in accordance with a coding method selecting signal and further selecting a signal from which a reproduced picture is calculated; **317** an orthogonal transform portion for performing an orthogonal transform of the prediction error signal; **319** a quantization portion for quantizing coefficients of an orthogonal transform; **321** a second quantization step-size computing portion for computing a second step size for the quantization; **322** a first quantization step-size computing portion for computing a first step size for the quantization; **325** an average and variance calculating portion for calculating the averaged value of the level of and a variance of the input television signal; **328** a code memory portion for temporarily storing a transmission frame; **330** an inverse orthogonal transform portion for effecting an inverse orthogonal transform of the quantized orthogonal transform coefficients; **334** a reproduced picture calculating portion for calculating a reproduced picture of a current frame; **336** a prediction error coding portion for performing what is called "transmitting channel coding" of a coding method selection signal, a prediction error, the first quantization step size and quantization class information; **338** a motion vector coding portion for performing the transmitting channel coding of a motion vector; **340** a multiplexer portion for computing a transmitting frame on the basis of the prediction code and the motion vector code; and **343** an output terminal from which a transmission signal is output.

Hereinafter, an operation of this motion compensated prediction interframe coding system having the above described arrangement will be described.

First, television signals are converted into digital television signals by an A/D conversion circuit (not shown). Then, pixels represented by the digital television signals are divided into blocks each of which is a rectangular array composed of $M \times N$ pixels arranged in M columns and N rows. Further, the digital television signals are input to the system from the input terminal **301** as input television signals **302**. Then, the motion vector calculating portion **303** compares the input television signal **302** with a reproduced picture signal **305** of a previous frame read from the picture memory portion **304** and calculating the motion of a coding block as a motion vector and moreover outputs a motion vector signal **306** representing the motion vector. Simultaneously, the motion vector calculating portion **303** judges from the result of the evaluation of the motion vector whether the motion compensation prediction made with respect to the coding block is effective or ineffective. Further, the motion vector calculating portion **303** outputs motion compensation prediction control information signal which represents the result of the judgement and is superposed on the motion vector signal **306**.

A motion compensation predicting portion **307** performs a motion compensation prediction of the reproduced television signal **305** of a previous frame in case where the motion compensation prediction control information indicates that the motion compensation prediction prediction is effective (i.e., the motion compensation prediction is effected by using motion vector) and outputs the reproduced television

signal without change as a motion compensation prediction signal **308** in case where the motion compensation prediction control information indicates that the motion compensation prediction is ineffective (i.e., the motion compensation prediction should not be effected).

The coding method selection portion **309** compares the input television signal **302** with the motion compensation prediction signal **308** every block and judges whether or not the motion compensation prediction is effective. Further, the coding method selection portion **309** judges that an intraframe coding method is effective for a current block in question in case where the motion compensation prediction is effective and that an interframe coding method is effective for a current block in question in case where the motion compensation prediction is not effective, and outputs a coding method selection signal **310** representing the result of this judgement. Further, in case of a coding system in which it is necessary to insert a refreshment frame between other frames, the portion **209** selects the coding method selection signal **310** in such a manner to code all of the blocks by use of the intra-frame coding method by inserting a refreshment frame between other frames every constant frame period.

Then, the intra-loop filtering portion **311** performs the two-dimensional lowpass filtering processing of the motion compensation prediction signal **308** in case where the motion compensation of a coding block is to be effected by using the motion vector and in another case, outputs the motion compensation prediction signal **308** as a prediction signal **312** without effecting the intra-loop filtering processing.

Subsequently, the prediction error evaluating portion **313** evaluates the difference between the input television signal **302** and the prediction signal **312** of the coding block and outputs a prediction error signal **314** representing the evaluated difference.

Thereafter, in case where the coding method selection signal **310** indicates that the intraframe coding method is selected, the switching portion **315** selects the input television **302** as a signal **316** to be transformed by performing the orthogonal transform. In contrast, in case where the coding method selection signal **310** indicates that the interframe coding method is selected, the switching portion **315** selects the prediction error signal **314** as a signal **316**.

Further, the orthogonal transform portion **317** performs the orthogonal transform of the signal **316** to remove therefrom effects of the high-degree correlation between each pair of the neighbors of a pixel corresponding to the signal **316** and further outputs an orthogonal transform coefficient signal **318** representing orthogonal transform coefficients. At that time, the DCT, which has a high efficiency of transform and of which firmware may be realized, is usually employed as the orthogonal transform.

Then, the quantization portion **319** quantizes the orthogonal transform coefficients represented by the signal **318** by using the second quantization step size. Hereinafter, a method of calculating the second quantization step size represented by a second quantization step size signal **320**.

(1) In case where a coding block is a block to be coded by the intraframe coding method:

The second quantization step size calculating portion **321** outputs the first quantization step size calculated by the first quantization step size calculating portion **322** from the amount of the remained code **323** by using the method described with reference to FIG. 1 as the second quantization step size.

(2) In case where a coding block is a block to be coded by the interframe coding method:

By effecting a process of steps (I) and (II) as will be described later, a variance of gray levels of pixels of the coding block is first calculated. Then, the block is divided into classes according to the calculated variance. Moreover, the second quantization step size actually used in the quantization for each class is calculated from the first quantization step size.

(I) The variance calculating portion **325** calculates an averaged value μ of the level of and a variance σ^2 of the input television signal **302** of the coding block from the following equations (9) and (10) and outputs an averaged value signal **344** and a variance signal **326** representing the calculated variance. Incidentally, the averaged value μ is used to judge whether or not the first quantization step size should be changed according to the fineness of the pattern of a block.

Further, the variance σ^2 is small in case where the fineness of a block represented by the input television signal **302** is high, while the variance σ^2 is large in case where the fineness of a block represented by the input television signal **302** is low.

$$\mu = (1/(M \times N)) \sum_{i=1}^M \sum_{j=1}^N (p(i, j)) \quad (9)$$

$$\sigma^2 = (1/(M \times N)) \sum_{i=1}^M \sum_{j=1}^N (p(i, j) - \mu)^2 \quad (10)$$

where M represents the number of columns (or pixels on a row) of a block; N the number of rows of the block; and p(i,j) a gray level of a pixel at an address (i,j) in the block.

(II) Further, the second quantization step size calculating portion **321** calculates a second quantization step size represented by a second quantization step size signal **320** and the quantization class information represented by a quantization class information signal **327** from the coding block variance signal **326**, the averaged value signal **344** (hereunder sometimes referred to as the coding block averaged value signal) corresponding to the coding block and the first quantization step size signal **324**. Further, the first quantization step size represented by the signal **324** is obtained by the first quantization step size calculating portion **322** from the amount **323** of the codes remained in the code memory **328** by using the method employed in the prior art system.

The second quantization step size calculating portion **321** compares the averaged value represented by the signal **344** and the variance represented by the signal **326** with each of four threshold values th1, th2, th3 and th4 with respect to a block to be coded by using the interframe coding method and divides each block into four quantization classes. Further, the second quantization step size represented by the second quantization step size signal **320** for each block obtained from the first quantization step size represented by the first quantization step size signal **324**. Incidentally, let Qb denote the first quantization step size; and Qstep the second quantization step size.

- ① In case where $0 \leq \sigma^2 < \text{th1}$ and $\mu > \text{th4}$, the class No. (Qstep Class)=1 and $Q\text{step} = (1/4)Qb$;
- ② In case where $\text{th1} \leq \sigma^2 < \text{th2}$ and $\mu > \text{th4}$, Qstep Class=2 and $Q\text{step} = (2/4)Qb$;
- ③ In case where $\text{th2} \leq \sigma^2 < \text{th3}$ and $\mu > \text{th4}$, Qstep Class=3 and $Q\text{step} = (3/4)Qb$; and
- ④ In case where $\text{th3} \leq \sigma^2$ and $\mu > \text{th4}$, Qstep Class=4 and $Q\text{step} = Qb$.

Thereby, the second quantization step size **320** used for quantizing a block to be coded by using the interframe

coding method is made to become smaller than the first quantization step size **324** in case where the averaged value of the level of the input television signal **302** is equal to or more than a predetermined constant value and the fineness of the picture pattern of the block is high.

Then, the quantization portion **319** quantizes the orthogonal transform coefficients **314** by using the second quantization step size **320** to obtain orthogonal transform quantization coefficients and outputs an orthogonal transform quantization coefficient signal **329** representing the orthogonal transform quantization coefficients. Further, the inverse orthogonal transform portion **330** performs the inverse orthogonal transform of the orthogonal transform quantization coefficients **329** and outputs a quantization-error-containing error signal **331** representing the result of the inverse orthogonal transform.

Further, the switching portion **316** selects a numerical-value-zero signal **333** as a reproduced picture calculating signal **332** in case where the coding method selection signal **310** selects the intraframe coding method. In contrast, the switching portion **316** selects the prediction signal **312** as the reproduced picture calculating signal **332** in case where the coding method selection signal **310** selects the interframe coding method.

Then, the reproduced picture calculating portion **334** adds the reproduced picture calculating signal **332** and the quantization-error-containing orthogonal transform signal **331** and outputs a reproduced picture signal **335** representing a reproduced picture of the coding block. Further, the picture memory **304** stores the reproduced picture signal **335** of the current frame and outputs the reproduced picture signal **305** of the previous frame.

Moreover, the prediction error coding portion **336** performs the coding of the orthogonal transform quantization coefficients represented by the signal **325**, the first quantization step size represented by the signal **324**, the quantization class information represented by the signal **327** and the information represented by the coding method selection signal **310** and outputs a prediction error code **337**.

Furthermore, the motion vector coding portion **338** performs the coding of the motion vector signal **306** and calculates a motion vector code, which is represented by a motion vector code signal **339**.

Thereafter, the multiplexer portion **340** calculates a transmission frame **341**, which has a predetermined format, from the prediction error code **337** and the motion vector code **339**.

Subsequently, the code memory portion **328** stores the transmission frame **341** once and further outputs the transmission frame **341** from the output terminal **343** in synchronization with a clock signal, which is inputted from an external circuit (not shown), as a transmission code represented by a transmission code signal **342**. Simultaneously, the code memory portion **328** calculates an amount of codes remained therein and outputs a signal **323** indicating the calculated amount of the remained codes.

As is apparent from the foregoing description, this embodiment calculates the second quantization step size from the first quantization step size as proportional to the fineness of the pattern of each block, which is coded by effecting the intra-frame coding method, among a group of continuous blocks, each of which is quantized by using a quantization step size, in case where the averaged value of the gray levels of pixels of an input picture is equal to or more than a predetermined constant value, and further quantizes the prediction error of a block having a fine pattern by using the second quantization step size. Thereby, the

picture quality of the entire reproduced picture can be improved without degrading the fineness of the pattern or texture of the picture.

Incidentally, the variance **326** calculated by the portion **325** is defined by the equation (9). However, any other kind of measure may be employed as the variance so long as it can be used to measure the fineness of a picture represented by the input television signal **302**. For example, the following measure D defined by an equation (11) may be employed because the size of a block is generally fixed (namely, the number of pixels on a row is M and that of rows is N) and the calculation thereof can be easily effected.

$$D = (1/(M \times N)) \sum_{i=1}^M \sum_{j=1}^N |p(i, j) - P| \quad (11)$$

where $p(i,j)$ denotes a gray level of a pixel at an address (i,j) in the block; and P the averaged value of the gray levels of the pixels of the block.

Further, in this embodiment, it is determined depending on the averaged value of the gray levels of the pixels of the input picture whether or not the first quantization step size should be changed. However, such determination may be made depending on another measure which can appropriately represent characteristics of the gray levels of the pixels of the entire input picture.

Furthermore, in this embodiment, the number of the classes is four, as above described. However, a different number may be employed as the number of the classes so long as the second quantization step size can be determined to be small for a block having a small variance. As described above, this embodiment first measures characteristics regarding the fineness of a picture pattern or texture of each block of picture, which is represented by an input television signal and is divided into a group of continuous blocks each quantized by using a quantization step size, and changes the quantization step size into a smaller one when quantizing a block having a fine pattern or texture and to be coded by effecting the intra-frame coding method, in case where the averaged value of the gray levels of the pixels of the entire input picture. Thereby, an amount of generated codes can be limited but the coding of a moving picture can be performed without degrading the fineness of the texture of the input or original picture. Further, the picture quality of the reproduced picture can be improved. Therefore, practically, the present invention is very advantageous. Especially, the picture quality of the refreshment frame can be substantially improved.

Next, a fourth embodiment of the present invention will be described hereinbelow with reference to FIG. 6.

In this figure, reference numeral **401** designates an input terminal from which television signals are inputted to the system; **403** a motion vector calculating portion for comparing a picture signal of a coding block of a current frame with a reproduced picture signal of a previous frame and calculating a motion vector; **404** a picture memory portion for storing reproduced picture signals of a current and previous frames; **407** a motion compensation predicting portion for performing a motion compensation predicting of the reproduced picture signals of the previous frame; **409** a coding method selection portion for selecting a method of coding of a block from an interframe coding and intraframe coding methods; **411** an intra-loop filter portion for performing two-dimensional lowpass filtering processing of a motion compensation predicting signal; **413** a prediction error evaluating portion for evaluating a prediction error by

computing the difference between an original picture signal and a predictive signal of a coding block; **415** a switch portion for selecting a signal, of which an orthogonal transform is effected, in accordance with a coding method selecting signal and further selecting a signal from which a reproduced picture is calculated; **417** an orthogonal transform portion for performing an orthogonal transform of the prediction error signal; **419** a quantization portion for quantizing coefficients of an orthogonal transform; **421** a second quantization step-size computing portion for computing a second step size for the quantization; **422** a first quantization step-size computing portion for computing a first step size for the quantization; **425** an average and variance calculating portion for calculating the averaged value of the level of and a variance of the input television signal; **428** a code memory portion for temporarily storing a transmission frame; **430** an inverse orthogonal transform portion for effecting an inverse orthogonal transform of the quantized orthogonal transform coefficients; **434** a reproduced picture calculating portion for calculating a reproduced picture of a current frame; **436** a prediction error coding portion for performing the "transmitting channel coding" of a coding method selection signal, a prediction error, the first quantization step size and quantization class information; **438** a motion vector coding portion for performing the transmitting channel coding of a motion vector; **440** a multiplexer portion for computing a transmitting frame on the basis of the prediction code and the motion vector code; and **443** an output terminal from which a transmission signal is output.

Hereinafter, an operation of this motion compensated prediction interframe coding system, having the above described arrangement will be described.

First, television signals are converted into digital television signals by an A/D conversion circuit (not shown). Then, pixels represented by the digital television signals are divided into blocks each of which is a rectangular array composed of $M \times N$ pixels arranged in M columns and N rows. Further, the digital television signals are input to the system from the input terminal **301** as input television signals **402**.

Then, the motion vector calculating portion **403** compares the input television signal **402** with a reproduced picture signal **405** of a previous frame read from the picture memory portion **404** and calculating the motion of a coding block as a motion vector and moreover outputs a motion vector signal **406** representing the motion vector. Simultaneously, the motion vector calculating portion **403** judges from the result of the evaluation of the motion vector whether the motion compensation prediction made with respect to the coding block is effective or ineffective. Further, the motion vector calculating portion **403** outputs motion compensation prediction control information signal which represents the result of the judgement and is superposed on the motion vector signal **406**.

A motion compensation predicting portion **407** performs a motion compensation prediction of the reproduced television signal **405** of a previous frame in case where the motion compensation prediction control information indicates that the motion compensation prediction prediction is effective (i.e., the motion compensation prediction is effected by using motion vector **406**) and outputs the reproduced television signal without change as a motion compensation prediction signal **408** in case where the motion compensation prediction control information indicates that the motion compensation prediction is ineffective (i.e., the motion compensation prediction should not be effected).

The coding method selection portion **409** compares the input television signal **402** with the motion compensation

signal 408 every block and judges whether or not the motion compensation prediction is effective. Further, the coding method selection portion 409 judges that an intraframe coding method is effective for a current block in question in case where the motion compensation prediction is effective and that an interframe coding method is effective for a current block in question in case where the motion compensation prediction is not effective, and outputs a coding method selection signal 410 representing the result of this judgement. Further, in case of a coding system in which it is necessary to insert a refreshment frame between other frames, the portion 409 selects the coding method selection signal 410 in such a manner to code all of the blocks by use of the intra-frame coding method by inserting a refreshment frame between other frames every constant frame period.

Then, the intra-loop filtering portion 411 performs the two-dimensional lowpass filtering processing of the motion compensation prediction signal 408 in case where the motion compensation of a coding block is to be effected by using the motion vector and in another case, outputs the motion compensation prediction signal 408 as a prediction signal 412 without effecting the intra-loop filtering processing.

Subsequently, the prediction error evaluating portion 413 evaluates the difference between the input television signal 402 and the prediction signal 412 of the coding block and outputs a prediction error signal 414 representing the evaluated difference.

Thereafter, in case where the coding method selection signal 410 indicates that the intraframe coding method is selected, the switching portion 415 selects the input television 402 as a signal 416 to be transformed by performing the orthogonal transform. In contrast, in case where the coding method selection signal 410 indicates that the interframe coding method is selected, the switching portion 415 selects the prediction error signal 414 as a signal 416.

Further, the orthogonal transform portion 417 performs the orthogonal transform of the signal 416 to remove therefrom effects of the high-degree correlation between each pair of the neighbors of a pixel corresponding to the signal 416 and further outputs an orthogonal transform coefficient signal 418 representing orthogonal transforms coefficients. At that time, the DCT, which has a high efficiency of transform and of which firmware may be realized, is usually employed as the orthogonal transform.

Then, the quantization portion 419 quantizes the orthogonal transform coefficients represented by the signal 418 by using the second quantization step size. Hereinafter, a method of calculating the second quantization step size represented by a second quantization step size signal 420.

(1) In case where a coding block is a block to be coded by the intraframe coding method or is not a block represented by a luminance signal (hereunder referred to as a luminance signal block):

The second quantization step size calculating portion 421 outputs the first quantization step size calculated by the first quantization step size calculating portion 422 from the amount of the remained code 423 by using the method described with reference to FIG. 1 as the second quantization step size.

(2) In case where a coding block is a block to be coded by the interframe coding method and is a luminance signal block:

By effecting a process of steps (1) and (2) as will be described later, a variance of gray levels of pixels of the coding block is first calculated. Then, the block is divided into classes according to the calculated variance. Moreover,

the second quantization step size actually used in the quantization for each class is calculated from the first quantization step size.

(1) The variance calculating portion 425 calculates an averaged value μ of the level of and a variance σ^2 of the input television signal 402 of the coding block from the following equations (12) and (13) and outputs an averaged value signal 444 and a variance signal 426 representing the calculated variance. Incidentally, the averaged value μ is used to judge whether or not the first quantization step size should be changed according to the fineness of the pattern of a block.

Further, the variance σ^2 is small in case where the fineness of a block represented by the input television signal 402 is high, while the variance σ^2 is large in case where the fineness of a block represented by the input television signal 402 is low.

$$\mu = (1/(M \times N)) \sum_{i=1}^M \sum_{j=1}^N (p(i, j)) \quad (12)$$

$$\sigma^2 = (1/(M \times N)) \sum_{i=1}^M \sum_{j=1}^N (p(i, j) - \mu)^2 \quad (13)$$

where M represents the number of columns (or pixels on a row) of a block; N the number of rows of the block; and p(i,j) a gray level of a pixel at an address (i,j) in the block.

(2) Further, the second quantization step size calculating portion 421 calculates a second quantization step size represented by a second quantization step size signal 420 and the quantization class information represented by a quantization class information signal 427 from the coding block variance signal 426, the coding block averaged value signal 444 and the first quantization step size signal 424. Further, the first quantization step size represented by the signal 424 is obtained by the first quantization step size calculating portion 422 from the amount 423 of the codes remained in the code memory 428 by using the method employed in the prior art system. The second quantization step size calculating portion 421 first modifies the predetermined threshold values th1-th4 according to the first quantization step size. A method of modifying the threshold values will be described hereinbelow.

That is, the portion 421 first compares the first quantization step size Qb with a predetermined threshold value thq.

(1) In case where $Qb \leq thq$,

The threshold values th1, th2, th3 and th4 are intact, namely, are not modified.

(2) In case where $Qb > thq$,

The threshold values th1, th2, th3 and th4 used for the classification are modified by the following equation (14):

$$th_i = -\{th_i / (\max - thq)\} (Qb - thq) + th_i \quad (14)$$

where a subscript i indicates an integer from 1 to 4; and "max" represents a maximum value of the quantization step size Qb.

FIG. 7 shows the relation between the quantization step size Qb and the threshold value th_i (i=1, 2, 3 and 4).

Next, the portion 421 compares the averaged value represented by the signal 444 and the variance represented by the signal 426 with each of the threshold values th1, th2, th3 and th4 with respect to a block, which is a luminance signal block and is to be coded by using the interframe coding method and divides each of such blocks into four quantiza-

tion classes. Further, the second quantization step size represented by the second quantization step size signal **420** for each block obtained from the first quantization step size represented by the first quantization step size signal **424**. Incidentally, let Q_b denote the first quantization step size; and Q_{step} the second quantization step size.

- ① In case where $0 \leq \sigma^2 < th1$ and $\mu > th4$, the class No. (Qstep Class)=1 and $Q_{step} = (1/4)Q_b$;
- ② In case where $th1 \leq \sigma^2 < th2$ and $\mu > th4$, Qstep Class=2 and $Q_{step} = (2/4)Q_b$;
- ③ In case where $th2 \leq \sigma^2 < th3$ and $\mu > th4$, Qstep Class=3 and $Q_{step} = (3/4)Q_b$; and
- ④ In case where $th3 \leq \sigma^2$ and $\mu > th4$, Qstep Class=4 and $Q_{step} = Q_b$.

Thereby, the second quantization step size **420** used for quantizing a block to be coded by using the interframe coding method is made to become smaller than the first quantization step size **424** in case where the averaged value of the level of the input television signal **402** is equal to or more than a predetermined constant value and the fineness of the picture pattern of the block is high. Further, when the first quantization step size is more than a predetermined constant value, the system modifies the threshold values th_i ($i=1, 2, 3$ and 4), so that the number of blocks to be quantized by using a quantization step size smaller than the first quantization step size can be decreased and the amount of the code corresponding to the luminance signal can be reduced and the discoloration of the coding block, which is due to the fact that the amount of the code corresponding to the color difference signal is extremely small, can be prevented.

Further, the quantization portion **419** quantizes the orthogonal transform coefficients **414** by using the second quantization step size **420** to obtain orthogonal transform quantization coefficients and outputs an orthogonal transform quantization coefficient signal **429** representing the orthogonal transform quantization coefficients. Further, the inverse orthogonal transform portion **430** performs the inverse orthogonal transform of the orthogonal transform quantization coefficients **429** and outputs a quantization-error-containing signal **431** representing the result of the inverse orthogonal transform.

Further, the switching portion **416** selects a numerical-value-zero signal **433** as a reproduced picture calculating signal **432** in case where the coding method selection signal **410** selects the intraframe coding method. In contrast, the switching portion **416** selects the prediction signal **412** as the reproduced picture calculating signal **432** in case where the coding method selection signal **410** selects the interframe coding method.

Then, the reproduced picture calculating portion **434** adds the reproduced picture calculating signal **432** and the quantization-error-containing signal **431** and outputs a reproduced picture signal **435** representing a reproduced picture of the coding block. Further, the picture memory **404** stores the reproduced picture signal **435** of the current frame and outputs the reproduced picture signal **405** of the previous frame.

Moreover, the prediction error coding portion **436** performs the coding of the orthogonal transform quantization coefficients represented by the signal **425**, a the first quantization step size represented by the signal **424**, the quantization class information represented by the signal **427** and the information represented by the coding method selection signal **410** and outputs a prediction error code **437**.

Furthermore, the motion vector coding portion **438** performs the coding of the motion vector signal **406** and

calculates a motion vector code, which is represented by a motion vector code signal **439** representing the motion vector code.

Thereafter, the multiplexer portion **440** calculates a transmission frame **441**, which has a predetermined format, from the prediction error code **437** and the motion vector code **439**.

Subsequently, the code memory portion **428** stores the transmission frame **441** once and further outputs the transmission frame **441** from the output terminal **443** in synchronization with a clock signal, which is inputted from an external circuit (not shown), as a transmission code represented by a transmission code signal **442**. Simultaneously, the code memory portion **428** calculates an amount of codes remained therein and outputs a signal **423** indicating the calculated amount of the remained codes.

As is apparent from the foregoing description, this embodiment calculates the second quantization step size from the first quantization step size as proportional to the fineness of the pattern of each block, which is coded by effecting the intra-frame coding method, among a group of continuous blocks, each of which is quantized by using a quantization step size, in case where the averaged value of the gray levels of pixels of an input picture is a predetermined constant value, and further quantizes the orthogonal transform coefficients by using the the second quantization step size. Thereby, the picture quality of the entire reproduced picture can be improved without degrading the fineness of the pattern or texture of the picture.

Further, as above described, when the first quantization step size is more than a predetermined constant value, the system modifies the threshold values th_i ($i=1, 2, 3$ and 4) for the classification, so that the number of blocks to be quantized by using a quantization step size smaller than the first quantization step size can be decreased and the amount of the code corresponding to the luminance signal can be reduced and the discoloration of the coding block, which is due to the fact that the amount of the code corresponding to the color difference signal is extremely small, can be prevented.

Incidentally, the variance **426** calculated by the portion **425** is defined by the equation (12). However, any other kind of measure may be employed as the variance so long as it can be used to measure the fineness of a picture represented by the input television signal **402**. For example, the following measure D defined by an equation (15) may be employed because the size of a block is generally fixed (namely, the number of pixels on a row is M and that of rows is N) and the calculation thereof can be easily effected.

$$D = (1 / (M \times N)) \sum_{i=1}^M \sum_{j=1}^N |p(i, j) - \mu| \quad (15)$$

where $p(i, j)$ denotes a gray level of a pixel at an address (i, j) in the block; and μ the averaged value of the gray levels of the pixels of the block.

Further, in this embodiment, it is determined depending on the averaged value of the gray levels of the pixels of the input picture whether or not the first quantization step size should be changed. However, such determination may be made depending on another measure which can appropriately represent characteristics of the gray levels of the pixels of the entire input picture.

Furthermore, in this embodiment, the number of the classes is also four, as above described. However, a classes is also four, as above described. However, a different number

may be employed as the number of the classes so long as the second quantization step size can be determined to be small for a block having a small variance.

Additionally, in this embodiment, the threshold values th_i ($i=1, 2, 3$ and 4) for the classification are modified by the equation (14). Apparently, another method of modifying the threshold values for the classification may be employed so long as the threshold values for the classification modified by the method becomes smaller when the quantization step sizes become larger.

While preferred embodiments of the present invention have been described above, it is to be understood that the present invention is not limited thereto and that other modifications will be apparent to those skilled in the art without departing from the spirit of the invention. The scope of the present invention, therefore, is to be determined solely by the appended claims.

What is claimed is:

1. A motion compensated prediction interframe coding system comprising:
 - a analog-to-digital conversion means for performing an analog-to-digital conversion of a television signal;
 - a block dividing means for dividing a predetermined area of the television signal digitalized by said analog-to-digital conversion means into blocks each having a predetermined size;
 - a motion vector calculating means for calculating a motion vector, which represents a motion of a television picture represented by the television signal, of each block and for judging with respect to each block whether or not the motion compensation is performed by using by the motion vector;
 - a motion compensation means for performing a motion compensation of a reproduced picture signal of a previous frame with respect to each block of which the motion compensation is determined by said motion vector calculating means to be effected and for calculating predicted gray levels of pixels of each block of which the motion compensation is effected;
 - a prediction error evaluating means for computing the difference between the gray level of each pixel of a coding block of the television picture and the predicted gray level thereof as a prediction error thereof;
 - an orthogonal transform means for performing an orthogonal transform of the prediction error of each pixel of a coding block of the television picture so as to obtain orthogonal transform coefficients;
 - a first quantization step-size computing means for computing a first step size for the quantization from an amount of generated codes;
 - a variance calculating means for calculating a variance of the gray levels of the pixels of each block of input television signal;
 - a second quantization step-size computing means for classifies the blocks into a predetermined number of classes according to the variance and computing a second step size for the quantization of each block from the first step size;
 - a quantization means for quantizing coefficients of an orthogonal transform by using the second step size to obtain quantized coefficients of orthogonal transform;
 - an orthogonal transform coefficient coding means for performing the coding of the prediction error, the first step size and information on the classes and the quantized coefficients of the orthogonal transform;

a quantized prediction error calculating means for effecting an inverse orthogonal transform of the quantized coefficients of the orthogonal transform to obtain quantized prediction errors;

a reproduced picture calculating means for calculating a reproduced picture from the quantized prediction errors and the predicted gray levels of the pixels of the blocks; a memory portion for storing the reproduced picture; and a motion vector coding means for performing the coding of the motion vectors.

2. A motion compensated prediction interframe coding system as set forth in claim 1 wherein the predetermined area is one frame.

3. A motion compensated prediction interframe coding system as set forth in claim 1 wherein the predetermined area is one field.

4. A motion compensated prediction interframe coding system comprising:

an analog-to-digital conversion means for performing an analog-to-digital conversion of a television signal;

a block dividing means for dividing a predetermined area of the television signal digitalized by said analog-to-digital conversion means into blocks each having a predetermined size;

a motion vector calculating means for calculating a motion vector, which represents a motion of a television picture represented by the television signal, of each block and for judging with respect to each block whether or not the motion compensation is performed by using by the motion vector;

a motion compensation means for performing a motion compensation of a reproduced picture signal of a previous frame with respect to each block of which the motion compensation is determined by said motion vector calculating means to be effected and for calculating predicted gray levels of pixels of each block of which the motion compensation is effected;

a prediction error evaluating means for computing the difference between the gray level of each pixel of a coding block of the television picture and the predicted gray level thereof as a prediction error thereof;

a coding method selection means for selecting a method of coding of a block from an interframe coding and intraframe coding methods;

a first switch means for selecting a signal, of which an orthogonal transform is effected, in accordance with the selection made by said coding method selecting means from the gray levels of pixels of blocks represented by the television signal and the prediction errors;

an orthogonal transform means for performing an orthogonal transform of the prediction error or the gray levels selected by said first switch means;

a first quantization step-size computing means for computing a first step size for the quantization from an amount of generated codes;

a variance calculating means for calculating a variance of the gray levels of the pixels of each block of input television signal;

a second quantization step-size computing means for classifying the blocks into a predetermined number of classes according to the variance and computing a second step size for the quantization of each block from the first step size in case of the blocks to be coded by using an intra-frame coding method and for treating the first step sizes as the second step sizes in case of the blocks to be coded by using an interframe coding method;

- a quantized transform coefficient calculating means for quantizing coefficients of an orthogonal transforms by using the second step size to obtain quantized coefficients of an orthogonal transform;
- an orthogonal transform coefficient coding means for performing information on the selection of the coding methods, the coding of the prediction error, the first step size and information on the classes and the quantized coefficients of the orthogonal transform;
- an inverse quantization means for effecting an inverse orthogonal transform of the quantized coefficients of the orthogonal transform to obtain inversely-quantized values;
- a second switch means for selecting a numerical value of zero as a gray level of a pixels of a reproduced picture in case where said coding method selection means selects the intraframe coding method and in contrast, selects the predicted value as the gray level of a pixel of the reproduced picture in case where the coding method selection means selects the interframe coding method;
- a reproduced picture calculating means for calculating a reproduced picture from the inversely-quantized values and the numerical value of zero or from the predicted gray levels of the pixels of the blocks;
- a memory portion for storing the reproduced picture; and
- a motion vector coding means for performing the coding of the motion vectors.
- 5.** A motion compensated prediction interframe coding system as set forth in claim 4 wherein the predetermined area, is one frame.
- 6.** A motion compensated prediction interframe coding system as set forth in claim 4 wherein the predetermined area is one field.
- 7.** A motion compensated prediction interframe coding system comprising:
- an analog-to-digital conversion means for performing an analog-to-digital conversion of a television signal;
 - a block dividing means for dividing a predetermined area of the television signal digitalized by said analog-to-digital conversion means into blocks each having a predetermined size;
 - a motion vector calculating means for calculating a motion vector, which represents a motion of a television picture represented by the television signal, of each block and for judging with respect to each block whether or not a motion compensation prediction is performed by using by the motion vector;
 - a motion compensation predicting means for performing a motion compensation prediction of a reproduced picture signal of a previous frame with respect to each block of which the motion compensation prediction is determined by said motion vector calculating means to be effected and for calculating predicted gray levels of pixels of each block of which the motion compensation prediction is effected;
 - a prediction error evaluating means for computing the difference between the gray level of each pixel of a coding block of the television picture and the predicted gray level thereof as a prediction error thereof;
 - a coding method selection means for selecting a method of coding of a block from an interframe coding and intraframe coding methods;
 - a first switch means for selecting a signal, of which an orthogonal transform is effected, in accordance with the

- selection made by said coding method selecting means from the gray levels of pixels of blocks represented by the television signal and the prediction errors;
 - an orthogonal transform means for performing an orthogonal transform of the prediction error or the gray levels selected by said first switch means;
 - a first quantization step-size computing means for computing a first step size for the quantization from an amount of generated codes;
 - an average and variance calculating means for calculating an averaged value and a variance of the gray levels of the pixels of each block of input television signal;
 - a second quantization step-size computing means for classifying the blocks into a predetermined number of classes according to the averaged value and variance and computing a second step size for the quantization of each block from the first step size in case of the blocks to be coded by using an intra-frame coding method and for treating the first step sizes as the second step sizes in case of the blocks to be coded by using an interframe coding method;
 - a quantized transform coefficient calculating means for quantizing coefficients of an orthogonal transform by using the second step size to obtain quantized coefficients of an orthogonal transform;
 - an orthogonal transform coefficient coding means for performing information on the selection of the coding methods, the coding of the prediction error, the first step size and information on the classes and the quantized coefficients of the orthogonal transform;
 - an inverse quantization means for effecting an inverse orthogonal transform of the quantized coefficients of the orthogonal transform to obtain inversely-quantized values;
 - a second switch means for selecting a numerical value of zero or the predicted gray level obtained by the motion compensation prediction as a gray level of a pixels of a reproduced picture according to the selection made by said coding method selection means;
 - a reproduced picture calculating means for calculating a reproduced picture from the inversely-quantized values and the numerical value of zero or from the predicted gray levels of the pixels of the blocks;
 - a memory portion for storing the reproduced picture; and
 - a motion vector coding means for performing the coding of the motion vectors.
- 8.** A motion compensated prediction interframe coding system as set forth in claim 7 wherein the predetermined area is one frame.
- 9.** A motion compensation prediction interframe coding system as set forth in claim 7 wherein the predetermined area is one field.
- 10.** A motion compensated prediction interframe coding system comprising:
- an analog-to-digital conversion means for performing an analog-to-digital conversion of a television signal;
 - a block dividing means for dividing a predetermined area of the television signal digitalized by said analog-to-digital conversion means into blocks each having a predetermined size;
 - a motion vector calculating means for calculating a motion vector, which represents a motion of a television picture represented by the television signal, of each block and for judging with respect to each block whether or not a motion compensation prediction is performed by using by the motion vector;

a motion compensation predicting means for performing a motion compensation prediction of a reproduced picture signal of a previous frame with respect to each block of which the motion compensation prediction is determined by said motion vector calculating means to be effected and for calculating predicted gray levels of pixels of each block of which the motion compensation prediction is effected;

a prediction error evaluating means for computing the difference between the gray level of each pixel of a coding block of the television picture and the predicted gray level thereof as a prediction error thereof;

a coding method selection means for selecting a method of coding of a block from an intraframe coding and interframe coding methods;

a first switch means for selecting a signal, of which an orthogonal transform is effected, in accordance with the selection made by said coding method selecting means from the gray levels of pixels of blocks represented by the television signal and the prediction errors;

an orthogonal transform means for performing an orthogonal transform of the prediction error or the gray levels selected by said first switch means;

a first quantization step-size computing means for computing a first step size for the quantization from an amount of generated codes;

an average and variance calculating means for calculating an averaged value and a variance of the gray levels of the pixels of each block of input television signal;

a threshold value modifying means for modifying predetermined threshold values according to the first step size to classify blocks, which are represented by luminance signals and are to be coded by effecting the intraframe coding method, into a predetermined number of classes;

a second quantization step-size computing means for classifying the blocks, which are represented by luminance signals and are to be coded by effecting the intraframe coding method, into the predetermined number of classes according to the averaged value and variance and computing a second step size for the quantization of each block from the first step size in case of the blocks to be coded by using an intraframe coding method and for treating the first step sizes as the second step sizes in case of the blocks to be coded by using an interframe coding method;

a quantized transform coefficient calculating means for quantizing coefficients of an orthogonal transform by using the second step size to obtain quantized coefficients of an orthogonal transform;

an orthogonal transform coefficient coding means for performing information on the selection of the coding methods, the coding of the prediction error, the first step size and information on the classes and the quantized coefficients of the orthogonal transform;

an inverse quantization means for effecting an inverse orthogonal transform of the quantized coefficients of the orthogonal transform to obtain inversely-quantized values;

a second switch means for selecting a numerical value of zero or the predicted gray level obtained by the motion compensation prediction as a gray level of a pixels of a reproduced picture according to the selection made by said coding method selection means;

a reproduced picture calculating means for calculating a reproduced picture from the inversely-quantized values

and the numerical value of zero or from the predicted gray levels of the pixels of the blocks;

a memory portion for storing the reproduced picture; and a motion vector coding means for performing the coding of the motion vectors.

11. A motion compensated prediction interframe coding system as set forth in claim **10** wherein the predetermined area is one frame.

12. A motion compensated prediction interframe coding system as set forth in claim **10** wherein the predetermined area is one field.

13. A motion compensated prediction interframe coding system as set forth in claim **1, 2, 3, 4, 5, 6, 7, 8, 9, 10, 11** or **12** wherein the variance is calculated from the following equation:

$$\sigma^2 = (1/(M \times N)) \sum_{i=1}^M \sum_{j=1}^N (p(i, j) - P)^2$$

where M represents the number of pixels on a row of a block; N the number of rows of the block; p(i,j) a gray level of a pixel at an address (i,j) in the block; and P the averaged value of the gray levels of the pixels of the block obtained by

$$P = (1/(M \times N)) \sum_{i=1}^M \sum_{j=1}^N p(i, j).$$

14. A motion compensated prediction interframe coding system as set forth in claim **1, 2, 3, 4, 5, 6, 7, 8, 9, 10, 11** or **12** wherein the variance is calculated from the following equation:

$$D = (1/(M \times N)) \sum_{i=1}^M \sum_{j=1}^N |p(i, j) - P|$$

where p(i,j) denotes a gray level of a pixel at an address (i,j) in the block; and P the averaged value of the gray levels of the pixels of the block given by

$$P = (1/(M \times N)) \sum_{i=1}^M \sum_{j=1}^N p(i, j).$$

15. A motion compensated prediction interframe coding system as set forth in claim **1, 2, 3, 4, 5, 6, 7, 8, 9, 10, 11** or **12** wherein the predetermined number of the classes is four.

16. A motion compensated prediction interframe coding system as set forth in claim **1, 2, 3, 4, 5, 6, 7, 8, 9, 10, 11** or **12** wherein the second step size is determined to be small for a block having a small variance.

17. A motion compensated prediction interframe coding system as set forth in claim **10, 11** or **12** wherein the threshold values are modified by using the following equation:

$$th_i = -\{th_i / (\max - th_q)\} (Q_b - th_q) + th_i$$

where a subscript i indicates an integer from 1 to 4; and "max" represents a maximum value of the first step size.

18. A moving-image signal encoding apparatus comprising:

37

a memory portion for storing codes;

means for computing a first step size for quantization from an amount of generated codes or from occupied capacity of the memory portion;

means for modifying the first quantization step size to obtain a second quantization step size; and

means for encoding a signal quantized in accordance with the second quantization step size.

19. A moving-image signal encoding apparatus as set forth in claim 18, wherein the second quantization step size is computed from the first quantization step size and a local image content.

20. A moving-image signal encoding apparatus as set forth in claim 19, wherein the local image content is judged from a value of a variance of an input television signal.

21. The moving-image signal encoding apparatus as set forth in claim 19, wherein the local image content is judged from both of a value of a variance and a value of average which are calculated from an input television signal.

22. A moving-image signal encoding apparatus comprising:

a memory portion for storing codes;

means for computing a first step size for the quantization of a signal from an amount of codes remained in the memory portion;

means for modifying the first quantization step size to obtain a second quantization step size;

means for quantizing the signal in accordance with the second quantization step size; and

means for encoding the quantized signal.

23. The moving-image signal encoding apparatus as set forth in claim 22, wherein the means for modifying the first quantization size computes the second quantization step size from both of the first quantization step size and a value of a local image characteristic measure which represents local characteristics of an input image represented by an input television signal.

24. The moving-image signal encoding apparatus as set forth in claim 23, wherein the local image characteristic measure is a variance of the input television signal.

25. The moving-image signal encoding apparatus as set forth in claim 23, wherein the local image characteristic measure is an average of the input television signal.

38

26. A method comprising the steps of:

computing a first step size for quantization from an amount of generated codes or from occupied capacity of a memory portion;

5 *modifying the first quantization step size to obtain a second quantization step size; and*

encoding a signal quantized in accordance with the second quantization step size.

27. The method as set forth in claim 26, wherein the step of modifying the first quantization step size comprises the sub-step of computing the second quantization step size from the first quantization step size and a local image content.

28. The method as set forth in claim 27, wherein the step of modifying the first quantization step size further comprises the sub-step of nudging the local image content from a value of a variance of an input television signal.

29. The method as set forth in claim 27, wherein the step of modifying the first quantization step size further comprises the sub-step of judging the local image content from both of a value of a variance and a value of average which are calculated from an input television signal.

30. A method comprising the steps of:

computing a first step size for the quantization of a signal from an amount of codes remained in a memory portion;

modifying the first quantization step size to obtain a second quantization step size;

quantizing the signal in accordance with the second quantization step size; and

encoding the quantized signal.

31. The method as set forth in claim 30, wherein the step of modifying the first quantization step size comprises the sub-step of computing the second quantization step size from both of the first quantization step size and a value of a local image characteristic measure which represents local characteristics of an input image represented by an input television signal.

32. The method as set forth in claim 31, wherein the local image characteristic measure is a variance of the input television signal.

33. The method as set forth in claim 31, wherein the local image characteristic measure is an average of the input television signal.

* * * * *