



US00RE36877E

United States Patent [19]

[11] E

Patent Number: Re. 36,877

Saito et al.

[45] **Reissued Date of Patent: Sep. 19, 2000**

[54] **PHOTOGRAPHIC CAMERA SYSTEM**

5,274,422 12/1993 Yoshikawa .

5,325,138 6/1994 Nagata .

[75] Inventors: **Takahiko Saito**, Kanagawa; **Akira Nakanishi**, Tokyo; **Shunzi Obayashi**, Tokyo; **Kyoji Genda**, Tokyo; **Hideki Toshikage**, Saitama, all of Japan

5,347,403 9/1994 Uekusa .

5,382,508 1/1995 Ikenoue .

5,453,815 9/1995 Yoshikawa .

5,471,265 11/1995 Shibata et al. .

[73] Assignee: **Sony Corporation**, Tokyo, Japan

FOREIGN PATENT DOCUMENTS

[*] Notice: This patent is subject to a terminal disclaimer.

0212443 3/1987 European Pat. Off. .

0357355 7/1990 European Pat. Off. .

1-282530 11/1989 Japan .

1282530 11/1989 Japan .

1282533 11/1989 Japan .

[21] Appl. No.: **08/865,113**

[22] Filed: **May 29, 1997**

OTHER PUBLICATIONS

Related U.S. Patent Documents

Reissue of:

[64] Patent No.: **5,583,591**

Issued: **Dec. 10, 1996**

Appl. No.: **08/329,546**

Filed: **Oct. 26, 1994**

U.S. Applications:

[63] Continuation-in-part of application No. 08/026,415, Mar. 4, 1993, abandoned.

Foreign Application Priority Data

Mar. 17, 1992 [JP] Japan 4-060684

Mar. 23, 1992 [JP] Japan 4-065304

[51] **Int. Cl.**⁷ **G03B 17/24**

[52] **U.S. Cl.** **396/311; 396/319; 396/429; 396/435**

[58] **Field of Search** **396/310, 311, 396/312, 315, 318, 60, 429, 435, 436; 355/40**

References Cited

U.S. PATENT DOCUMENTS

4,650,304 3/1987 Harvey .

4,777,515 10/1988 Aikoh et al. 396/311

4,931,829 6/1990 Hakamada .

4,965,627 10/1990 Robison .

5,066,971 11/1991 Kodaira 396/435

5,086,311 2/1992 Naka et al. .

5,151,726 9/1992 Iwashita et al. 396/429

Patent Abstracts of Japan, vol. 14, No. 59, (Iwashita et al.), Feb. 2, 1990.

Patent Abstracts of Japan, vol. 6, No. 121 (Itou), Jul. 6, 1982.

Fujifilm Advanced Photo System Minilab Guide, Unknown Publication Date.

Kodak Advantix, Internet Information found at the Kodak Website, Unknown Publication Date.

Primary Examiner—David M. Gray

Attorney, Agent, or Firm—Jay H. Maioli

[57] **ABSTRACT**

A photographic camera system includes a photographic camera that can successively expose a photographic film in different frame sizes and an automatic printer for automatically printing the processed photographic film exposed with those different frame sizes. The camera varies the width of an exposure opening in the camera body in the film-feed direction and the film is fed a length corresponding to the width of the exposure opening. The photographic camera magnetically or optically records an exposure opening position signal indicative of the size of the exposure opening on the photographic film, and the automatic printer automatically prints the photographic film using the magnetically or optically recorded exposure opening position signal detected from the photographic film.

52 Claims, 17 Drawing Sheets

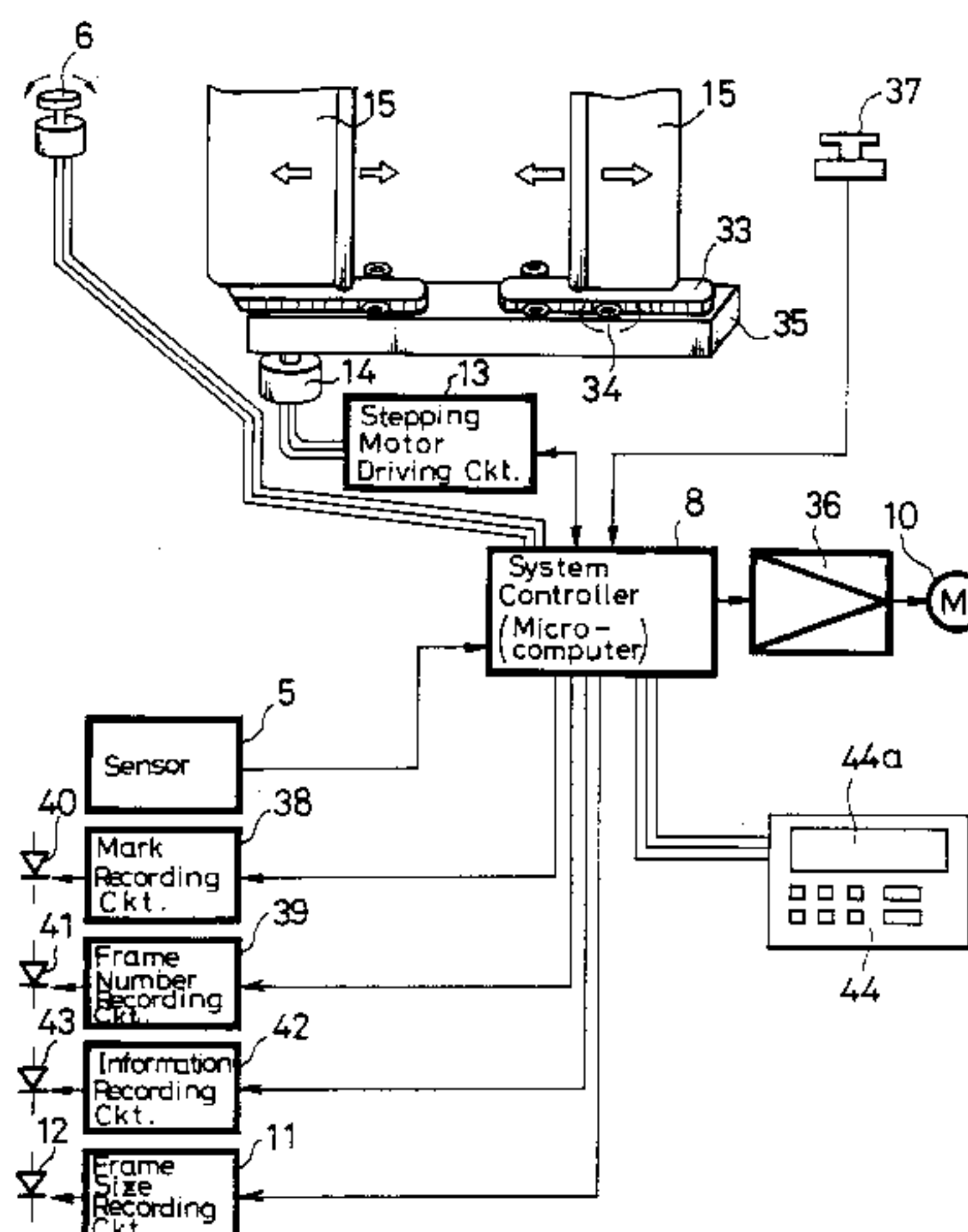

FIG. 2

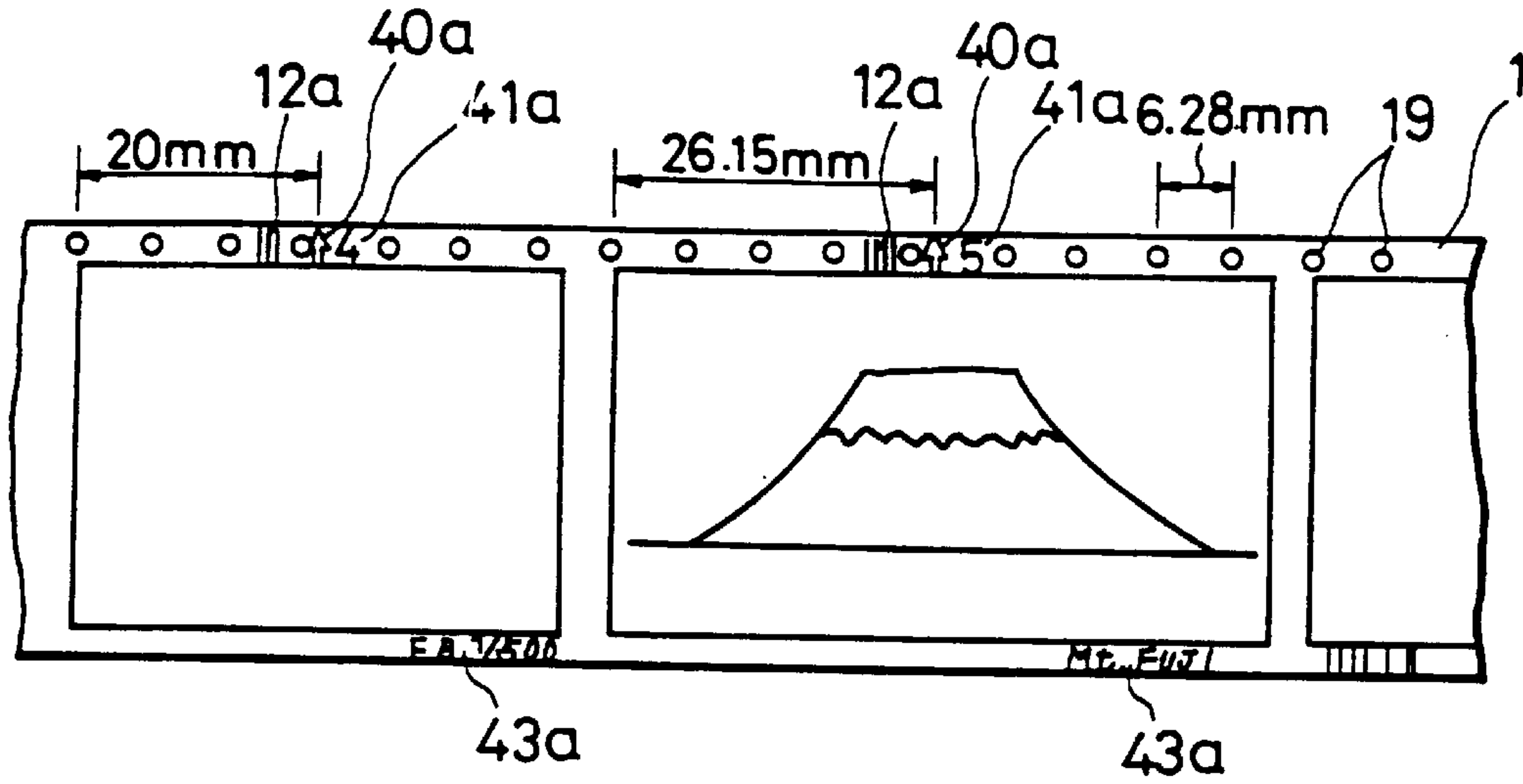

FIG. 3A

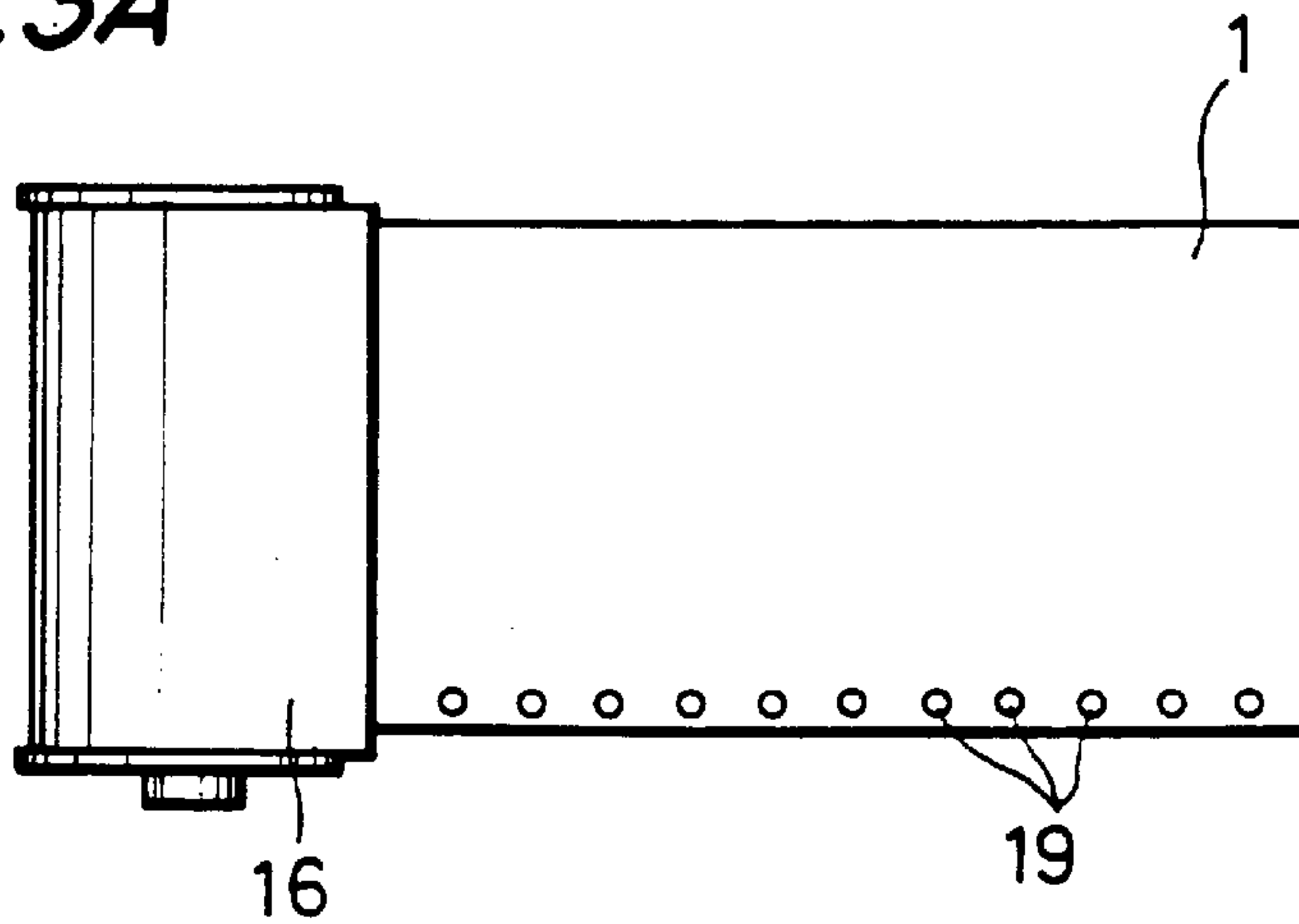
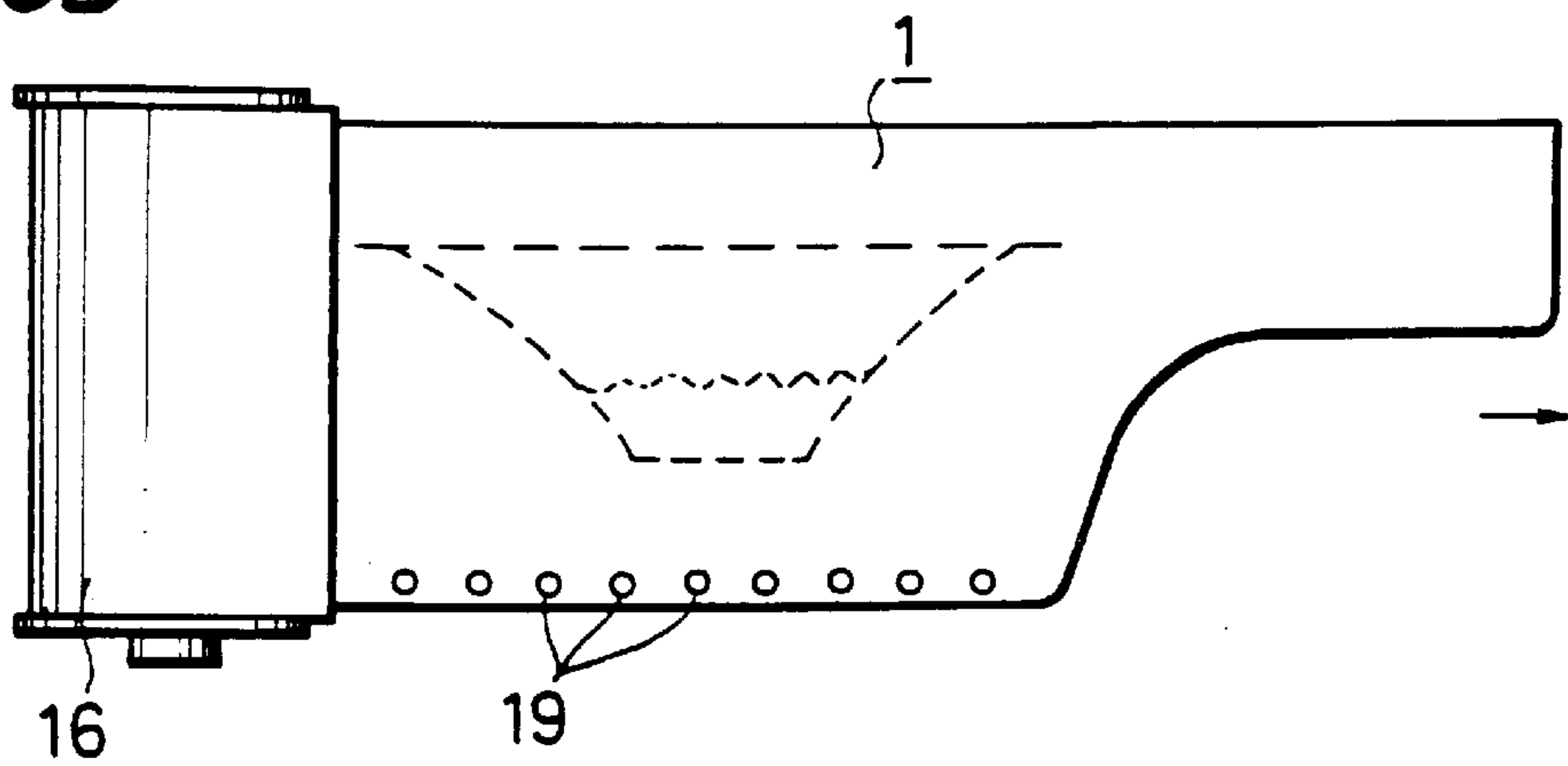

FIG. 3B



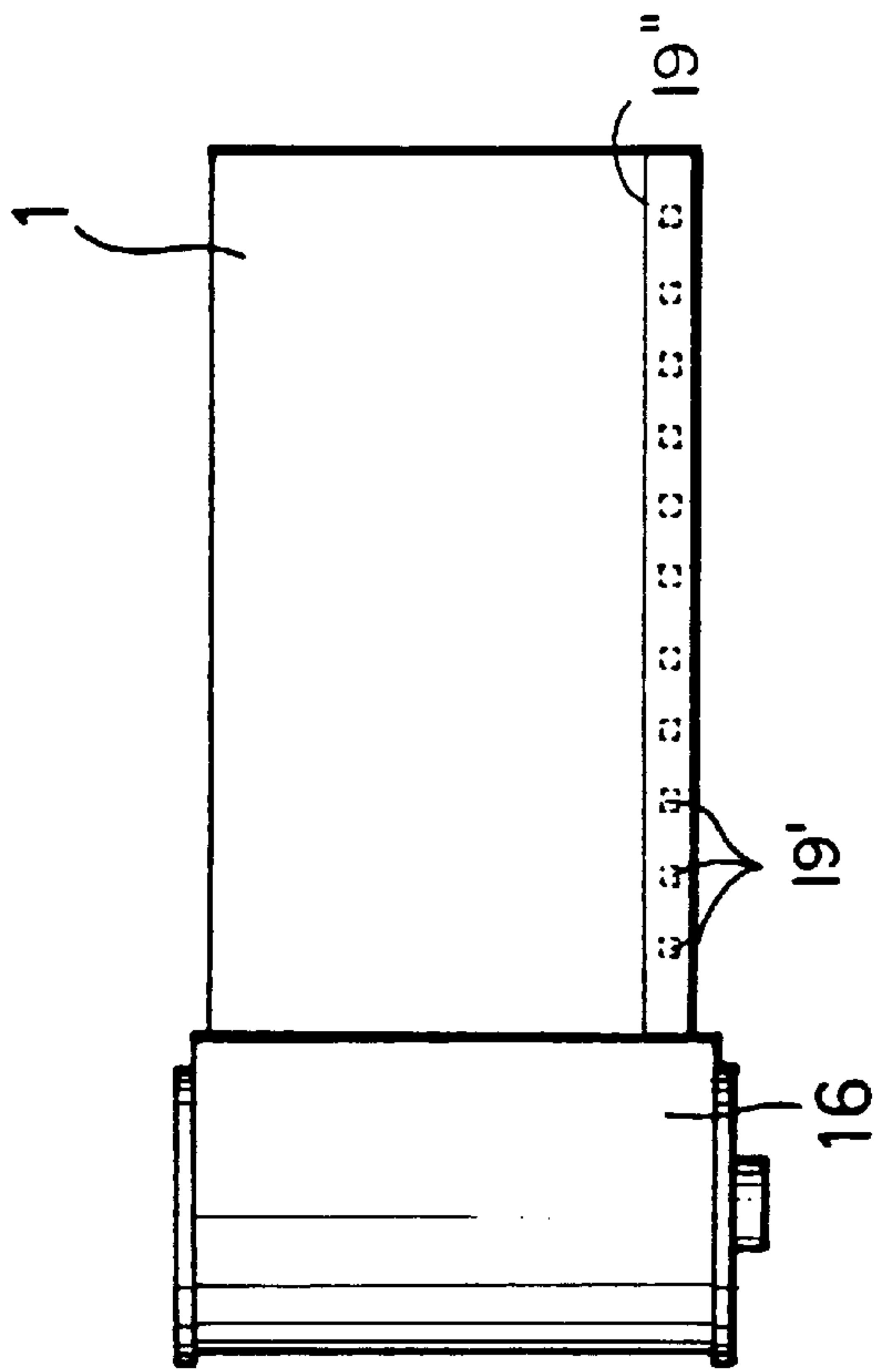

FIG. 4A

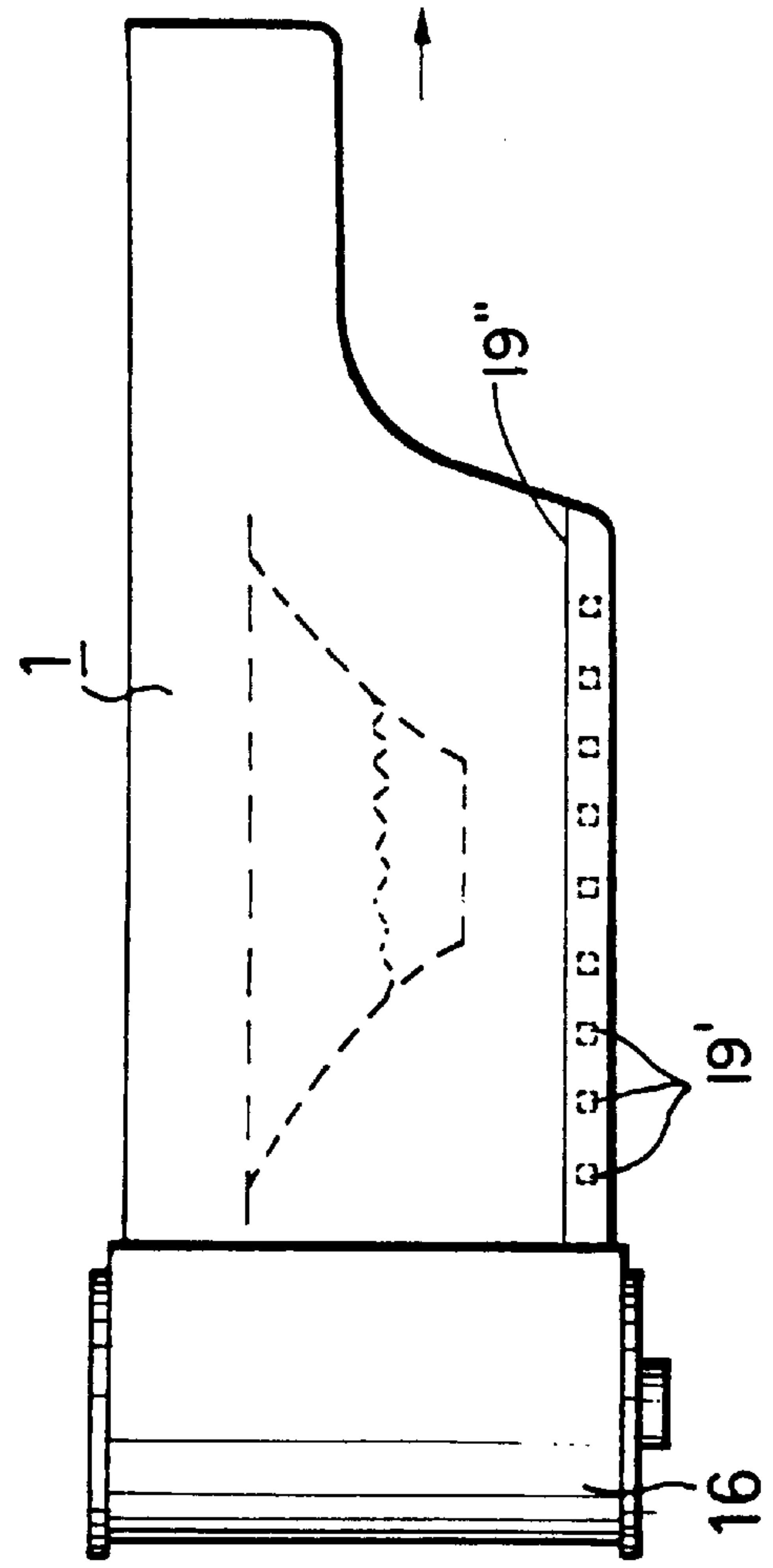

FIG. 4B

FIG. 5

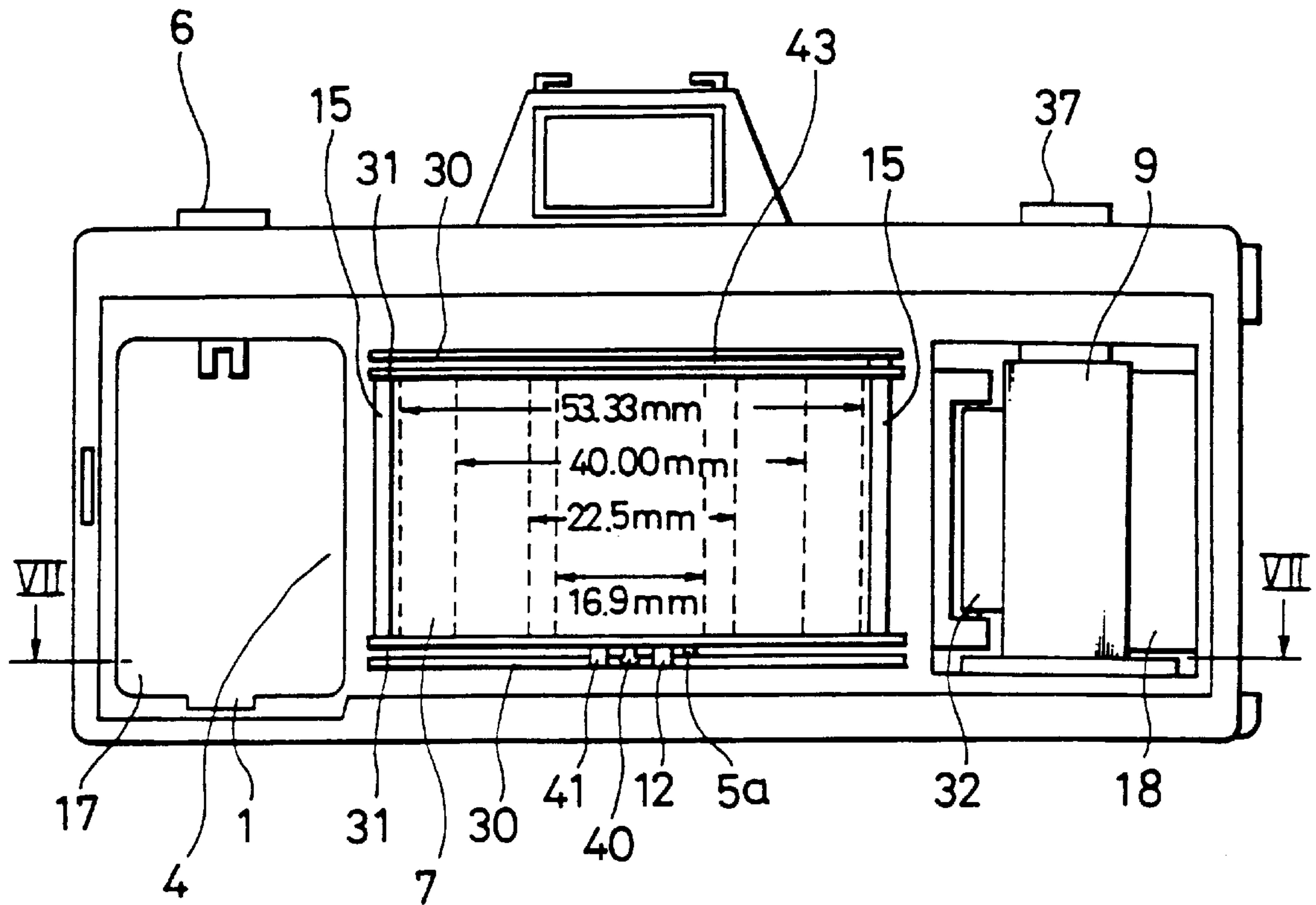

FIG. 6

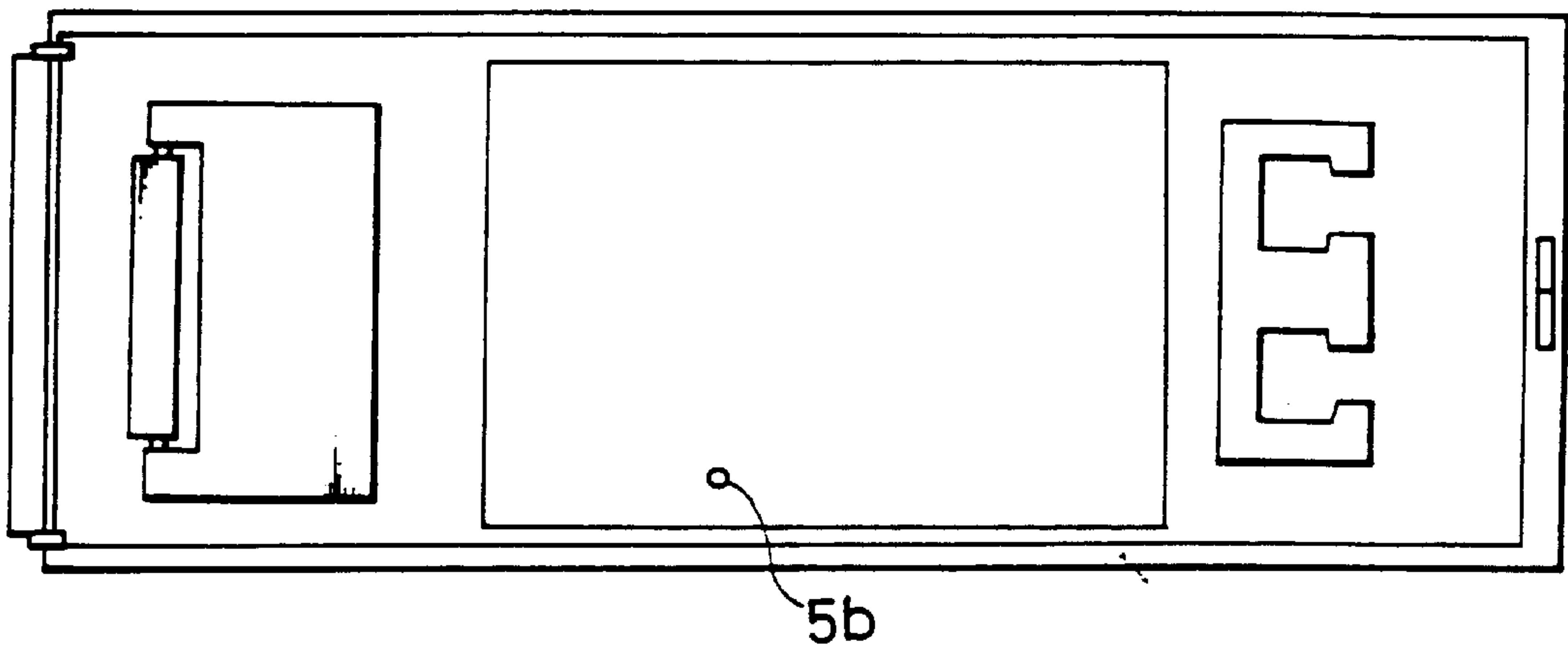

FIG. 7

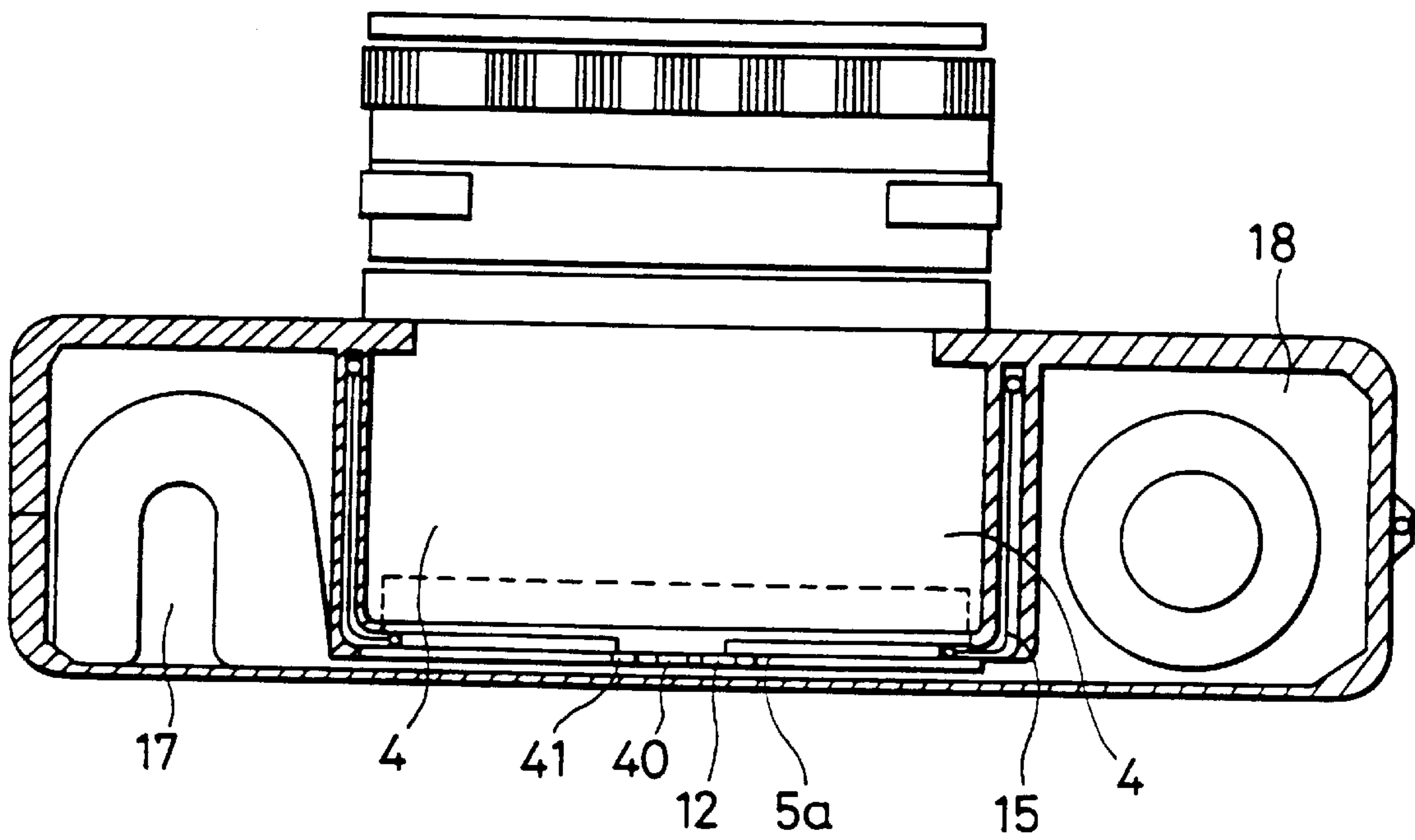

FIG. 8

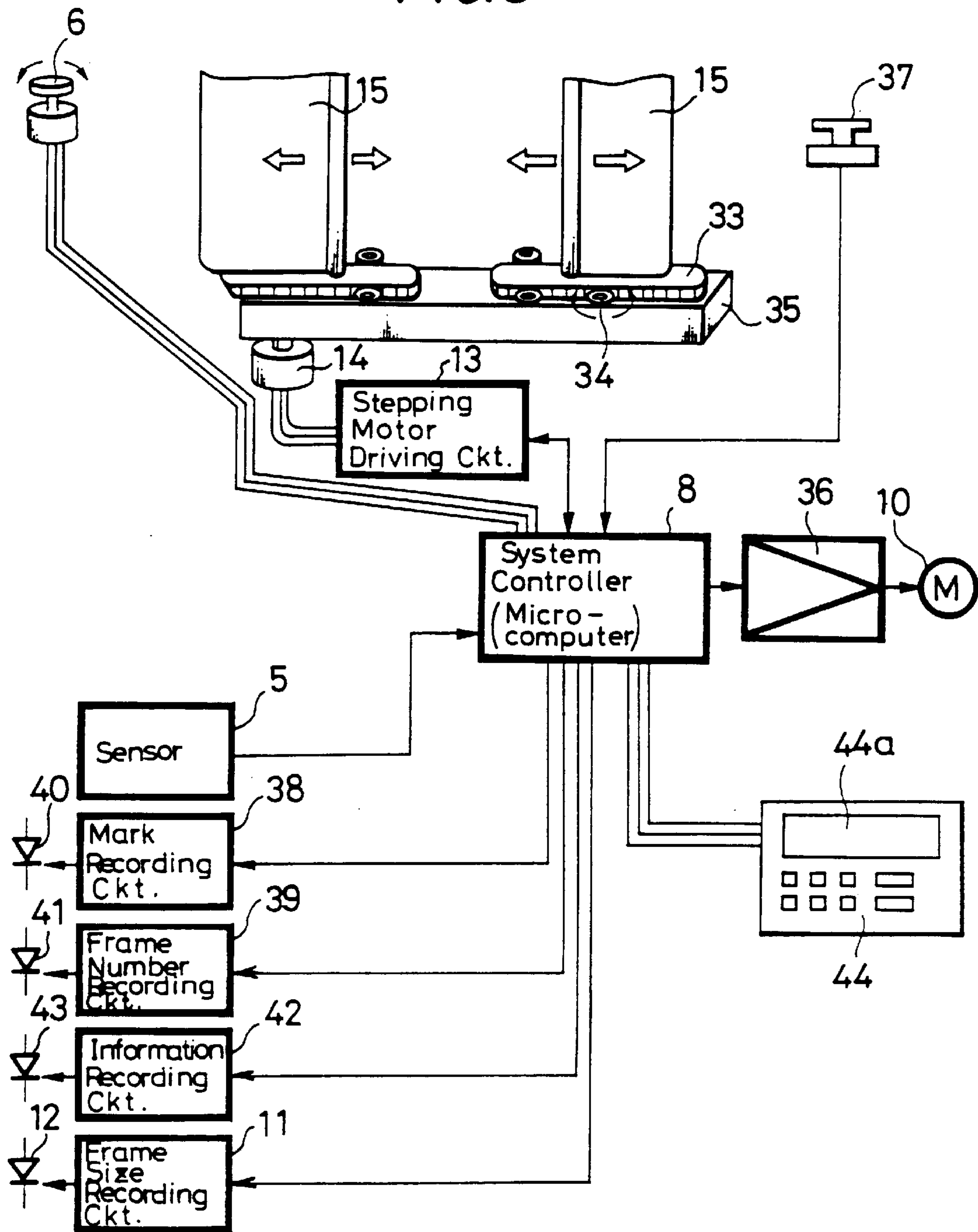

FIG. 9

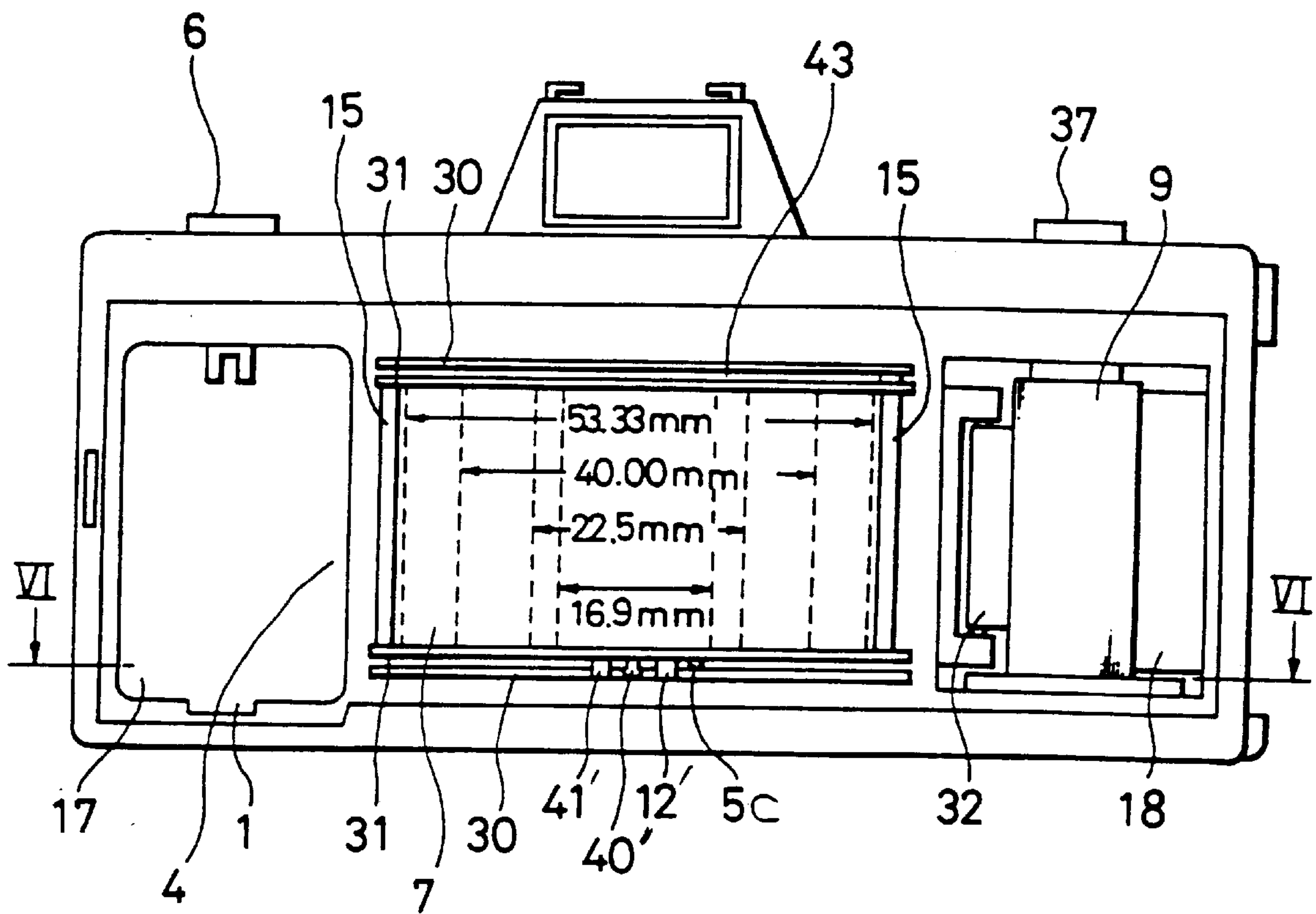
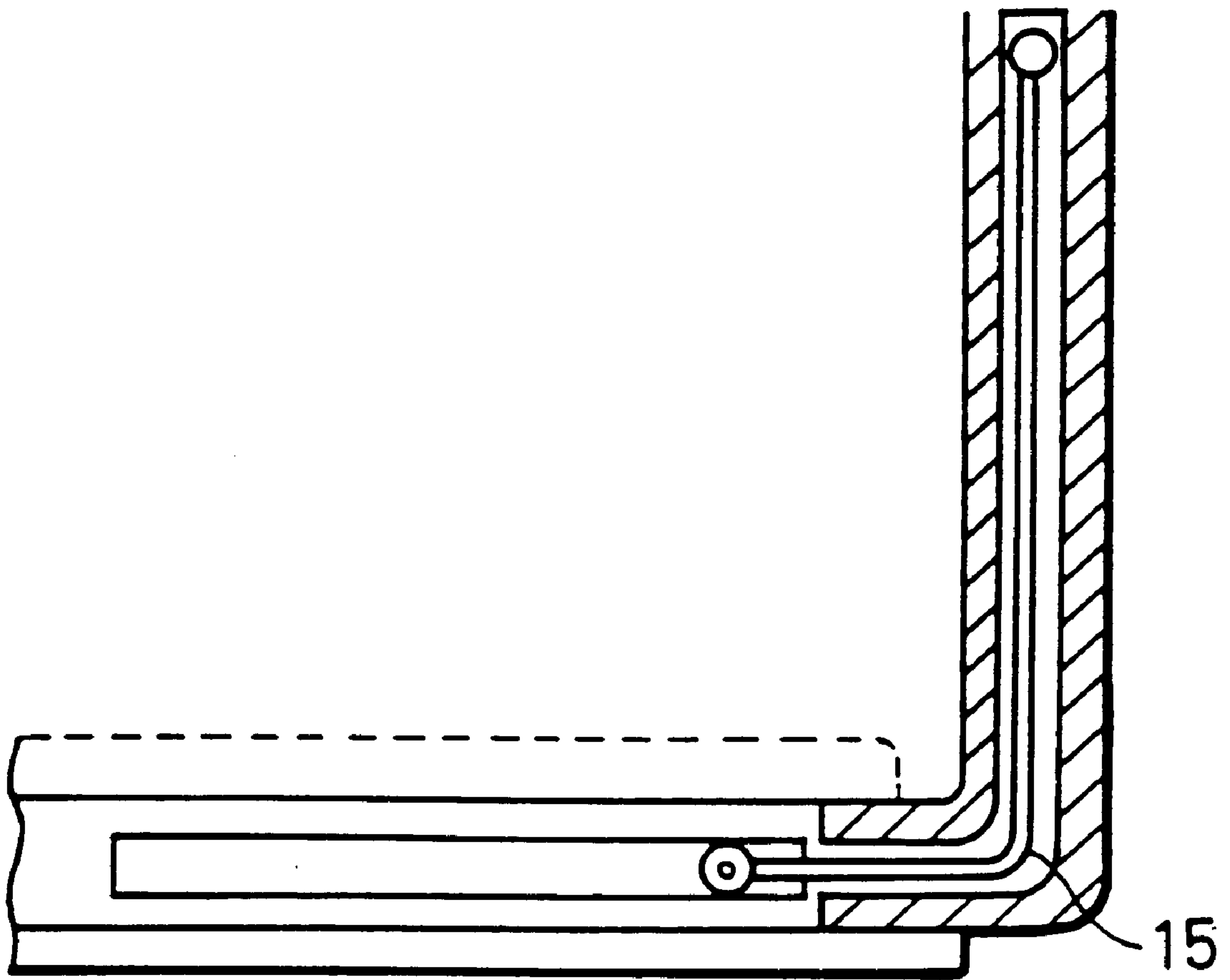

FIG. 10



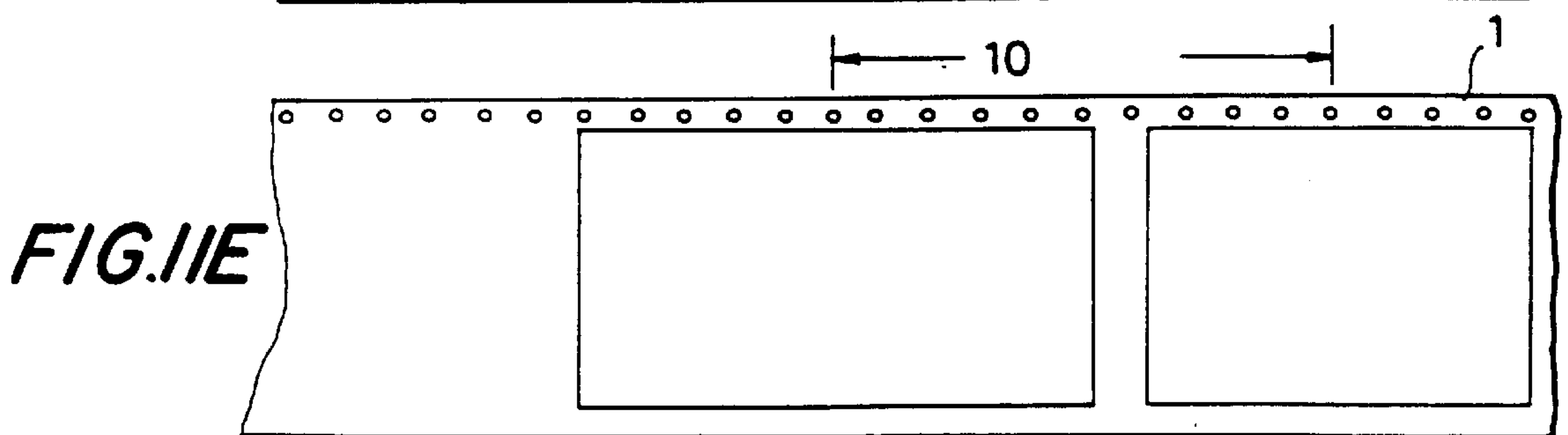
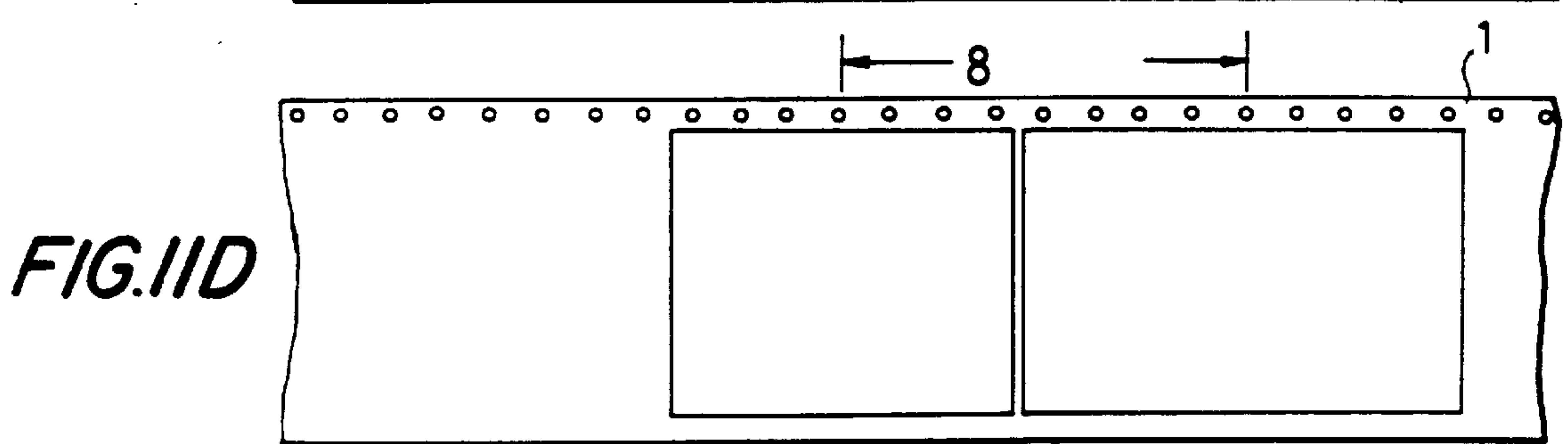
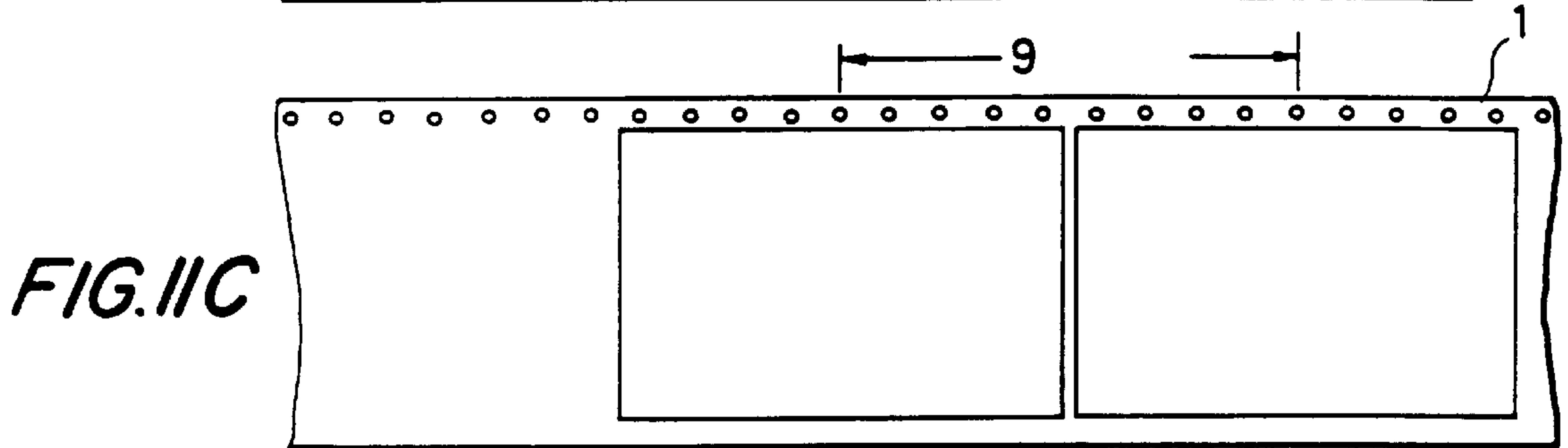
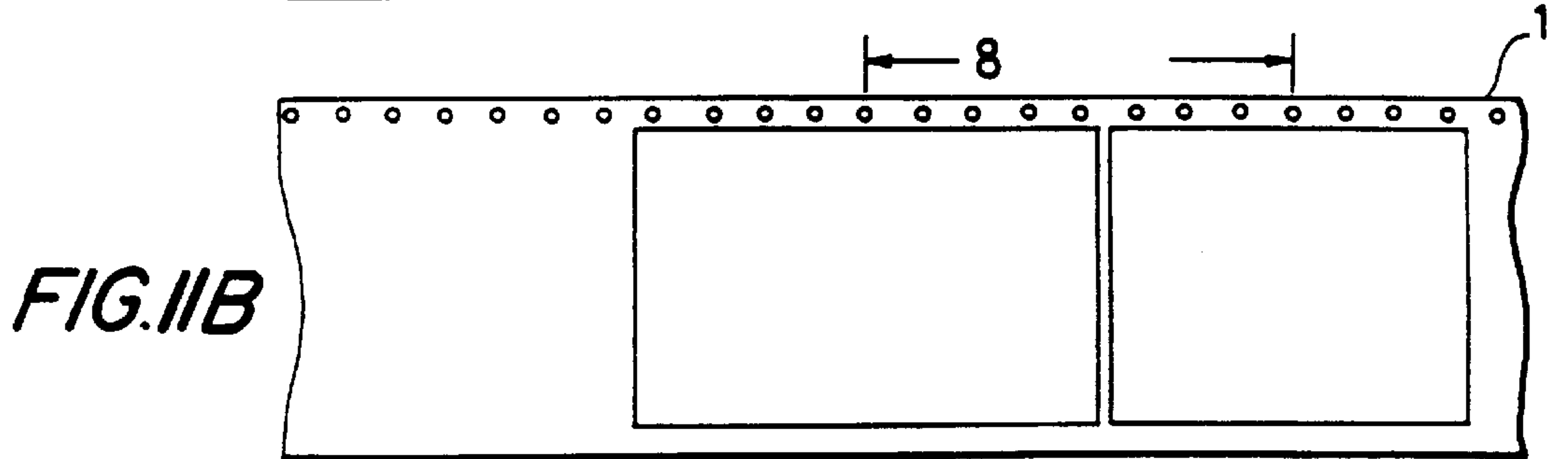
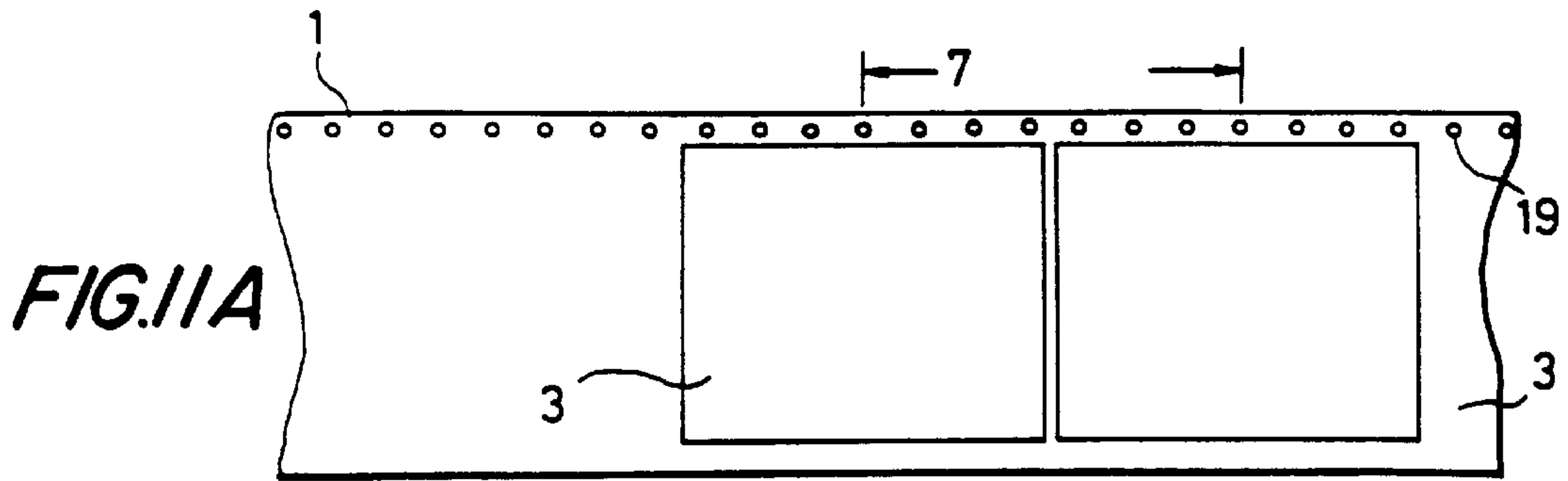

FIG. 12

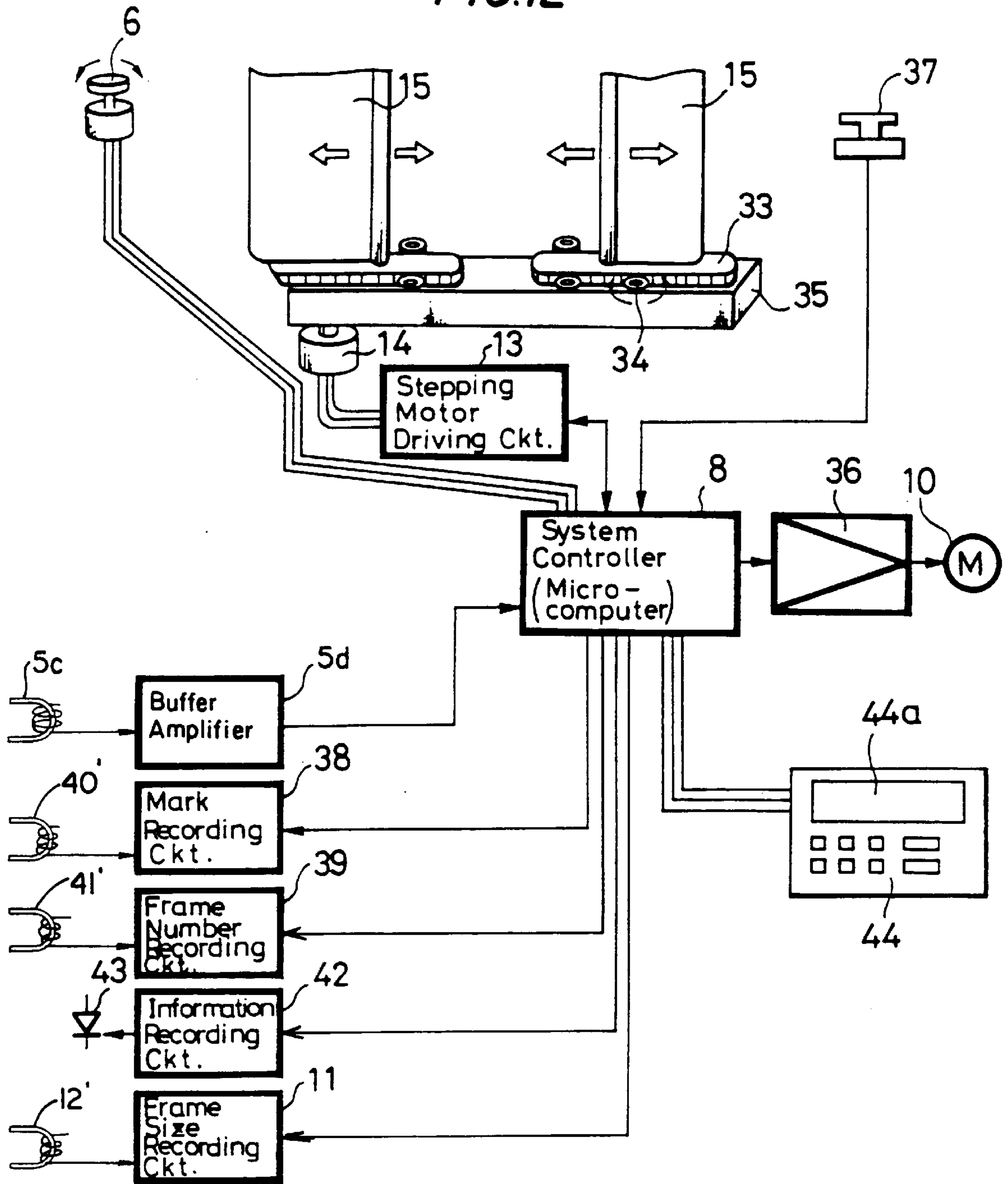

FIG. 14

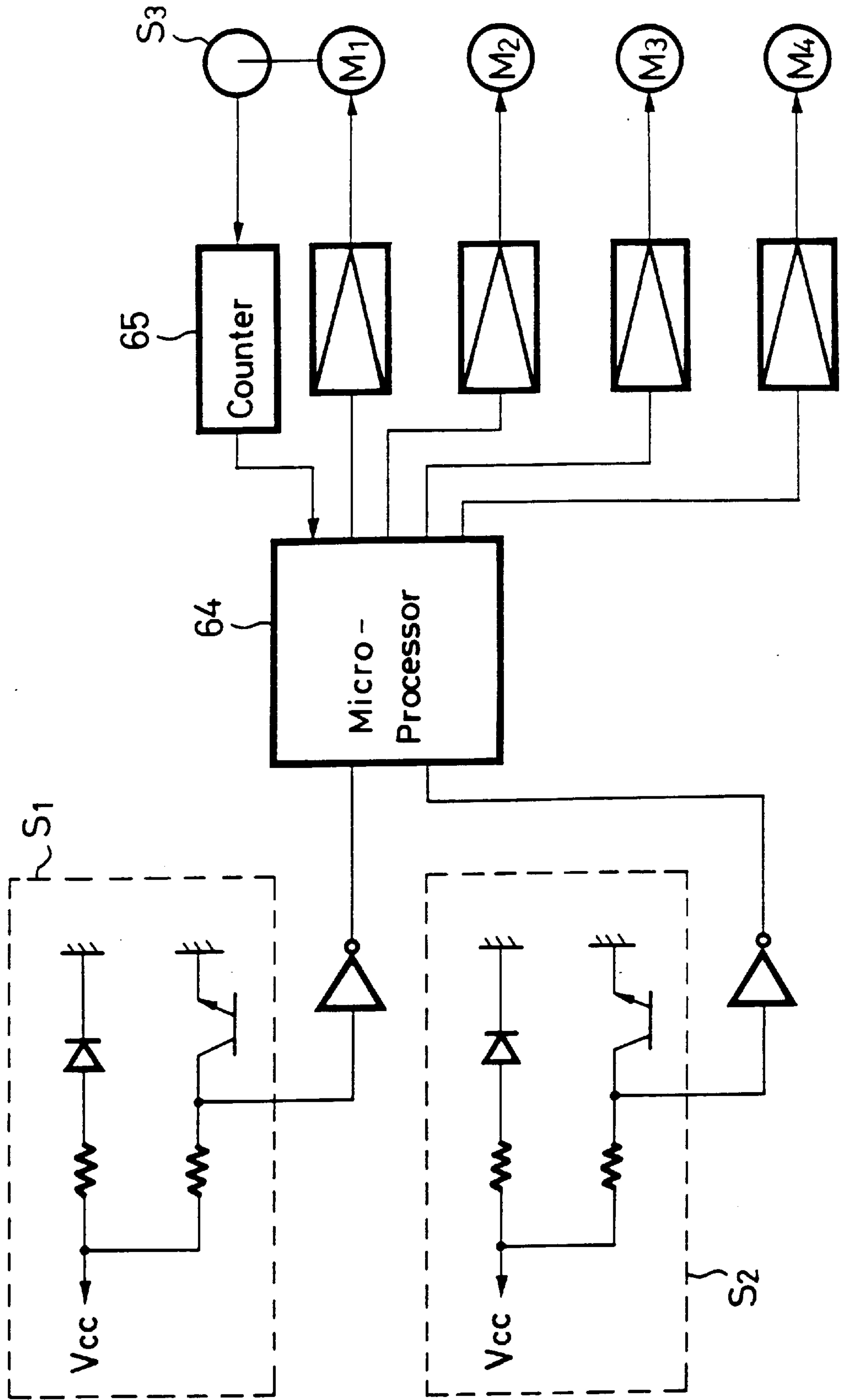
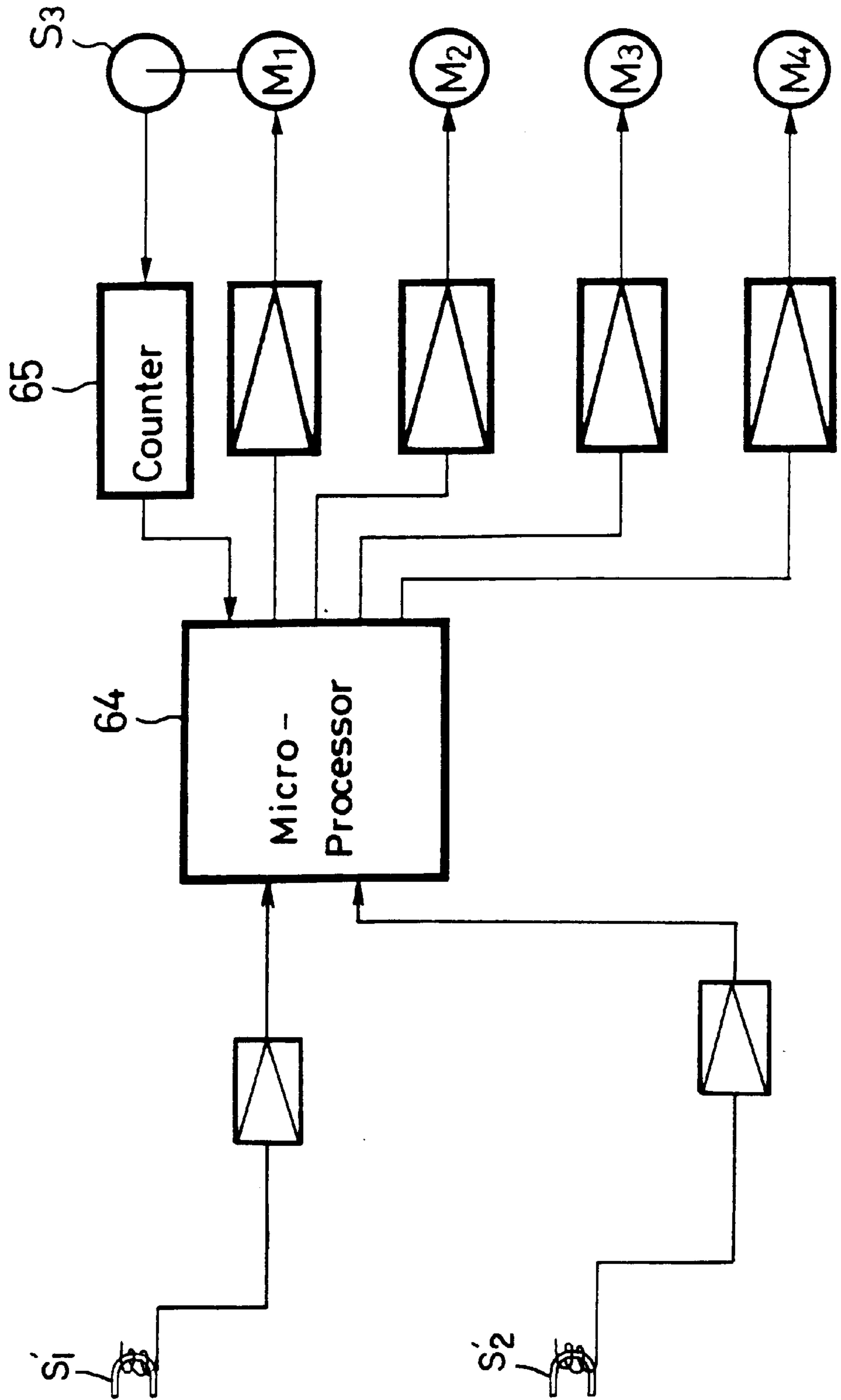

FIG. 15



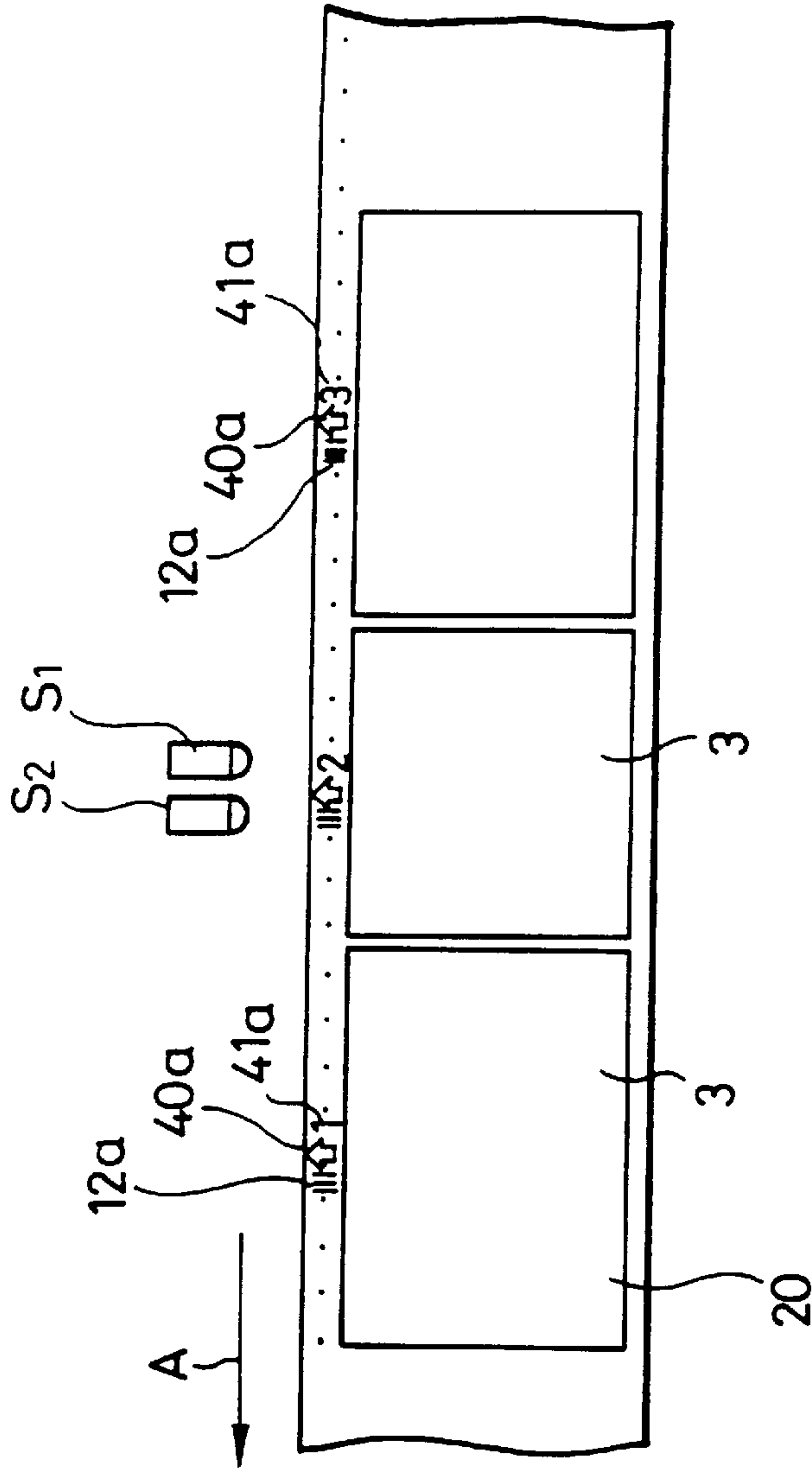

FIG. 16A

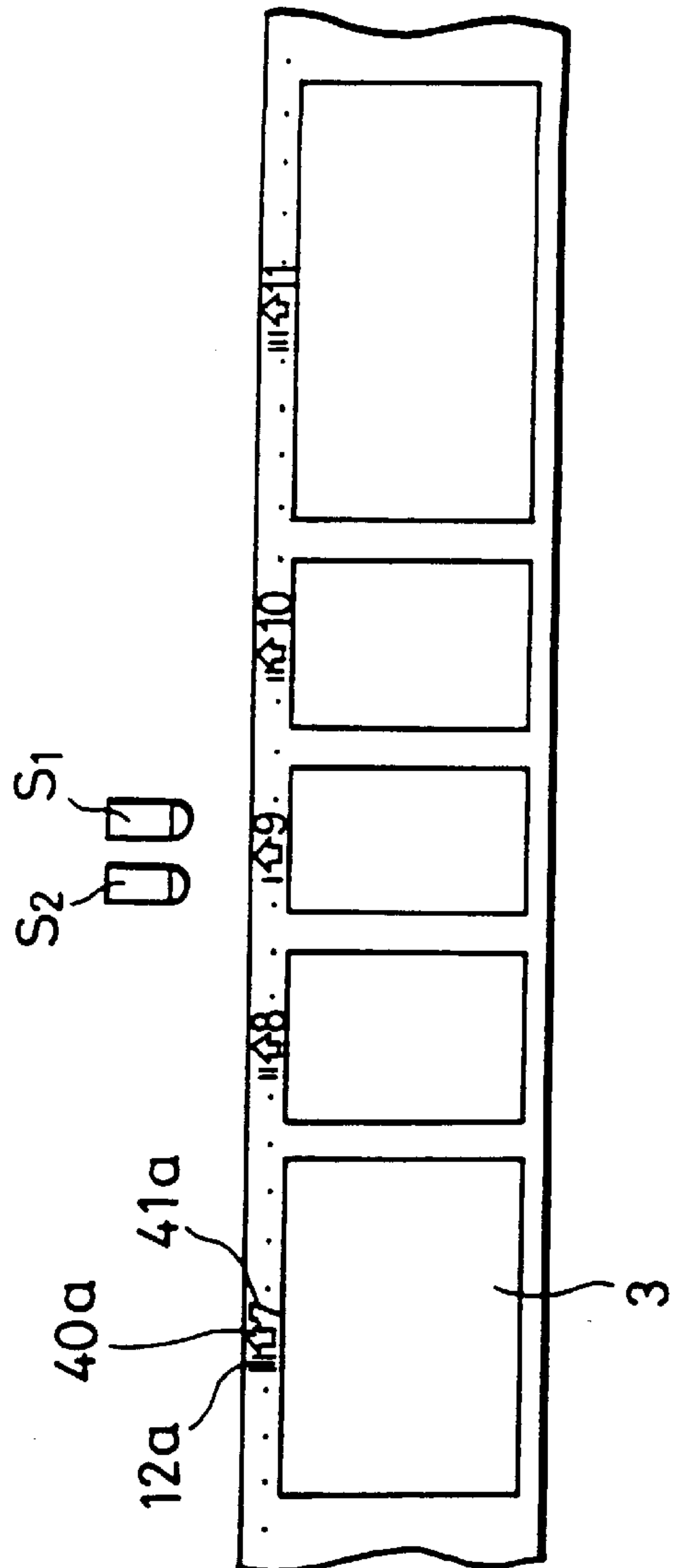

FIG. 16B

FIG.17

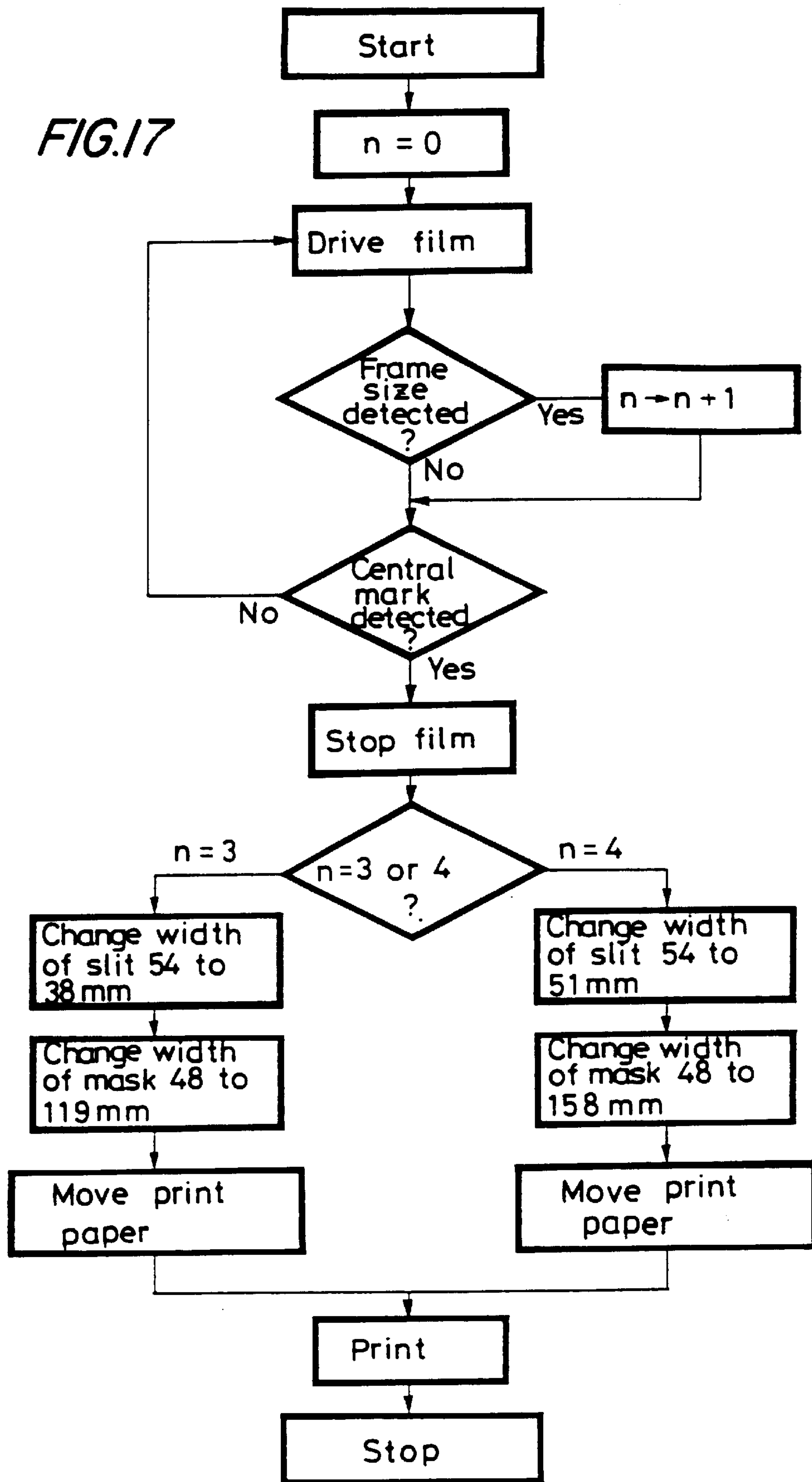

FIG. 18A

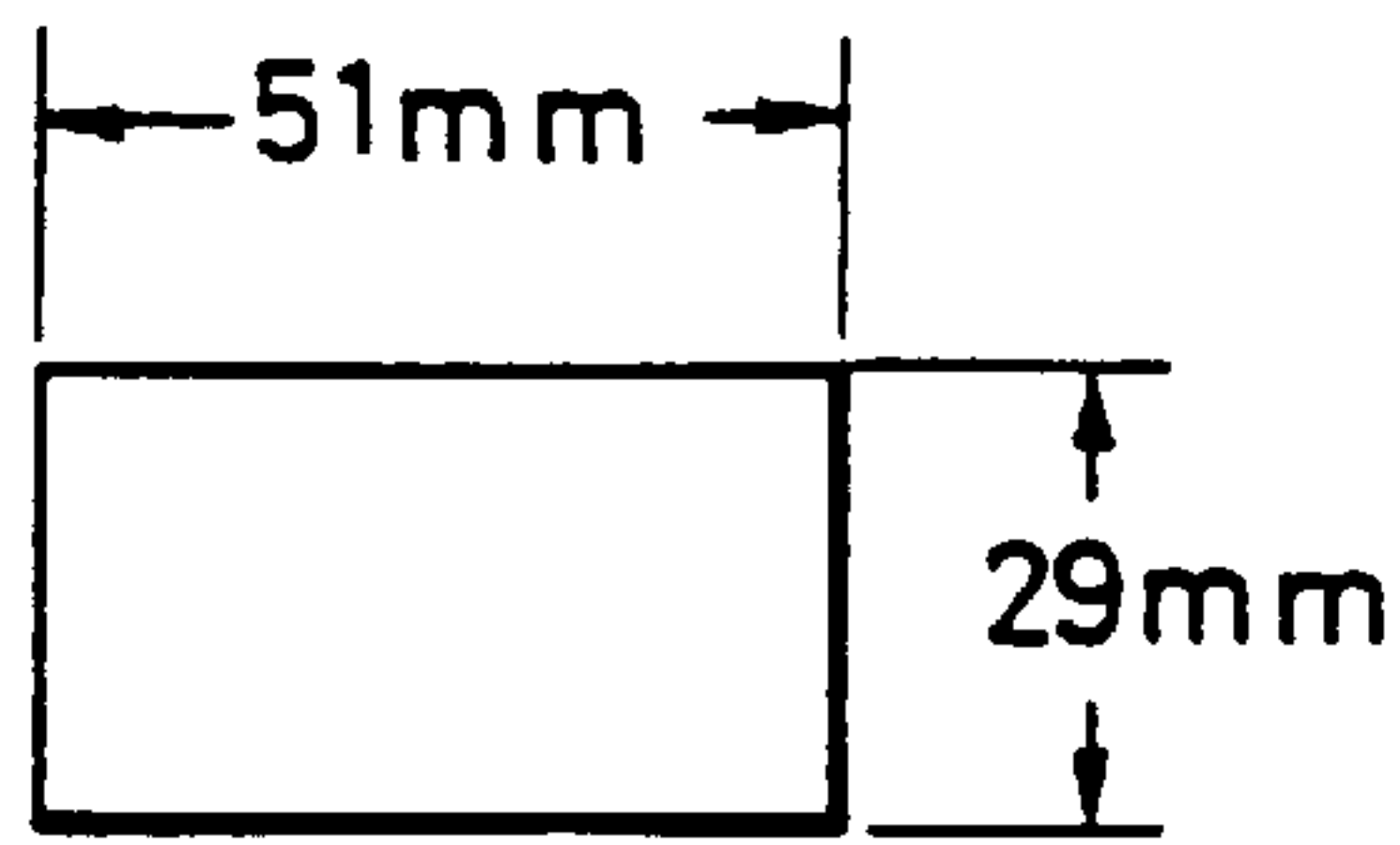

FIG. 18B

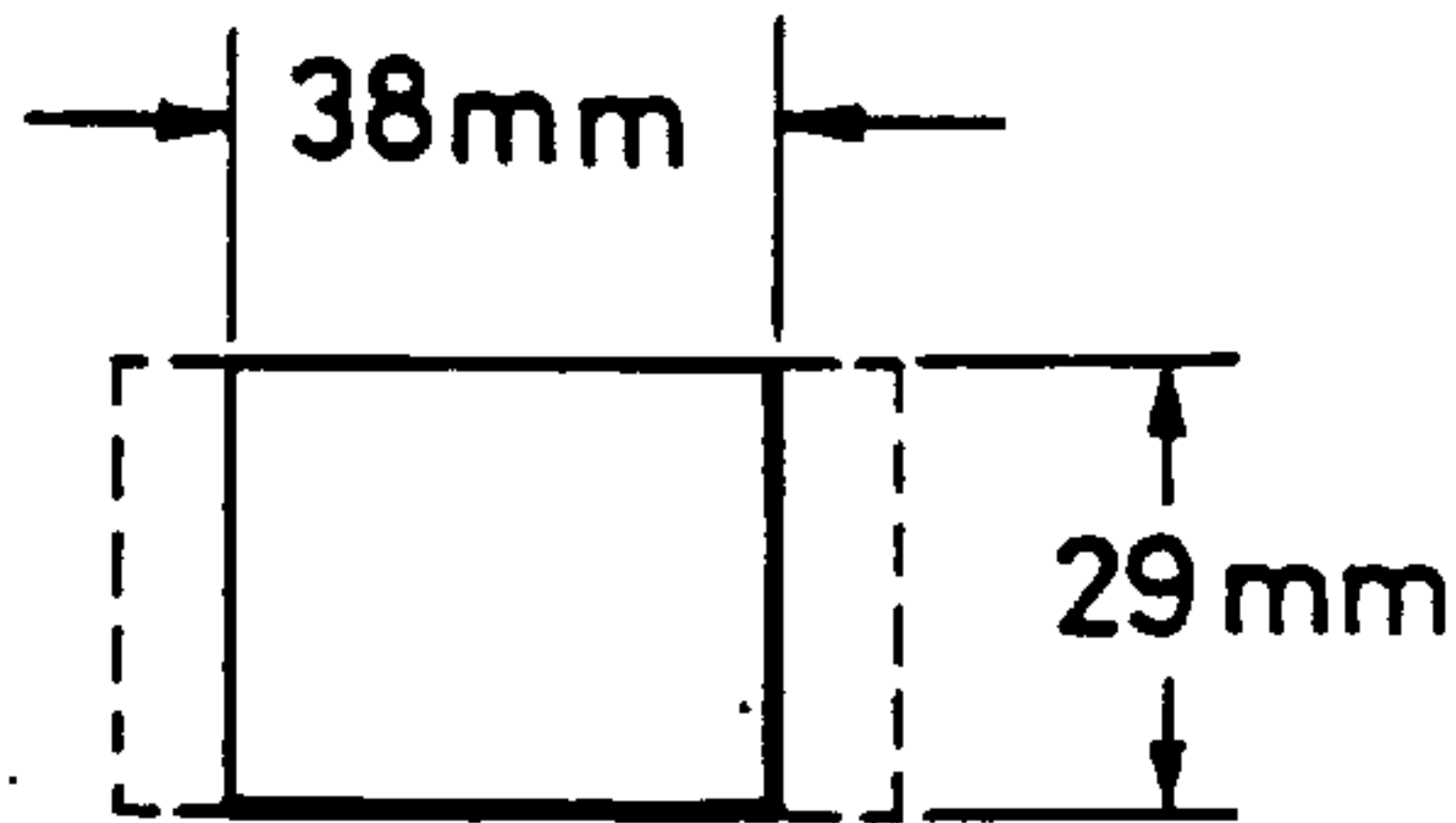

FIG. 19A

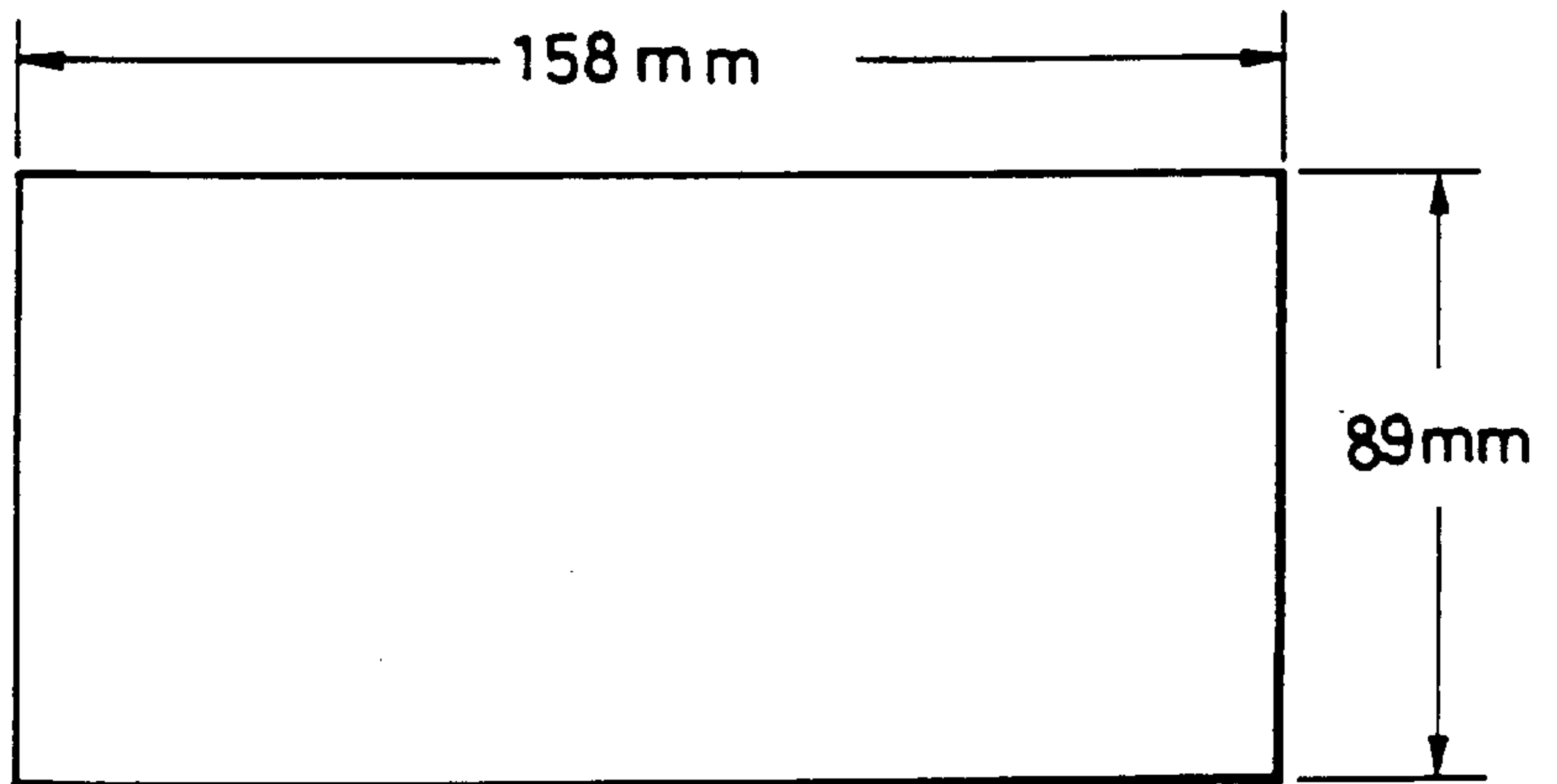

FIG. 19B

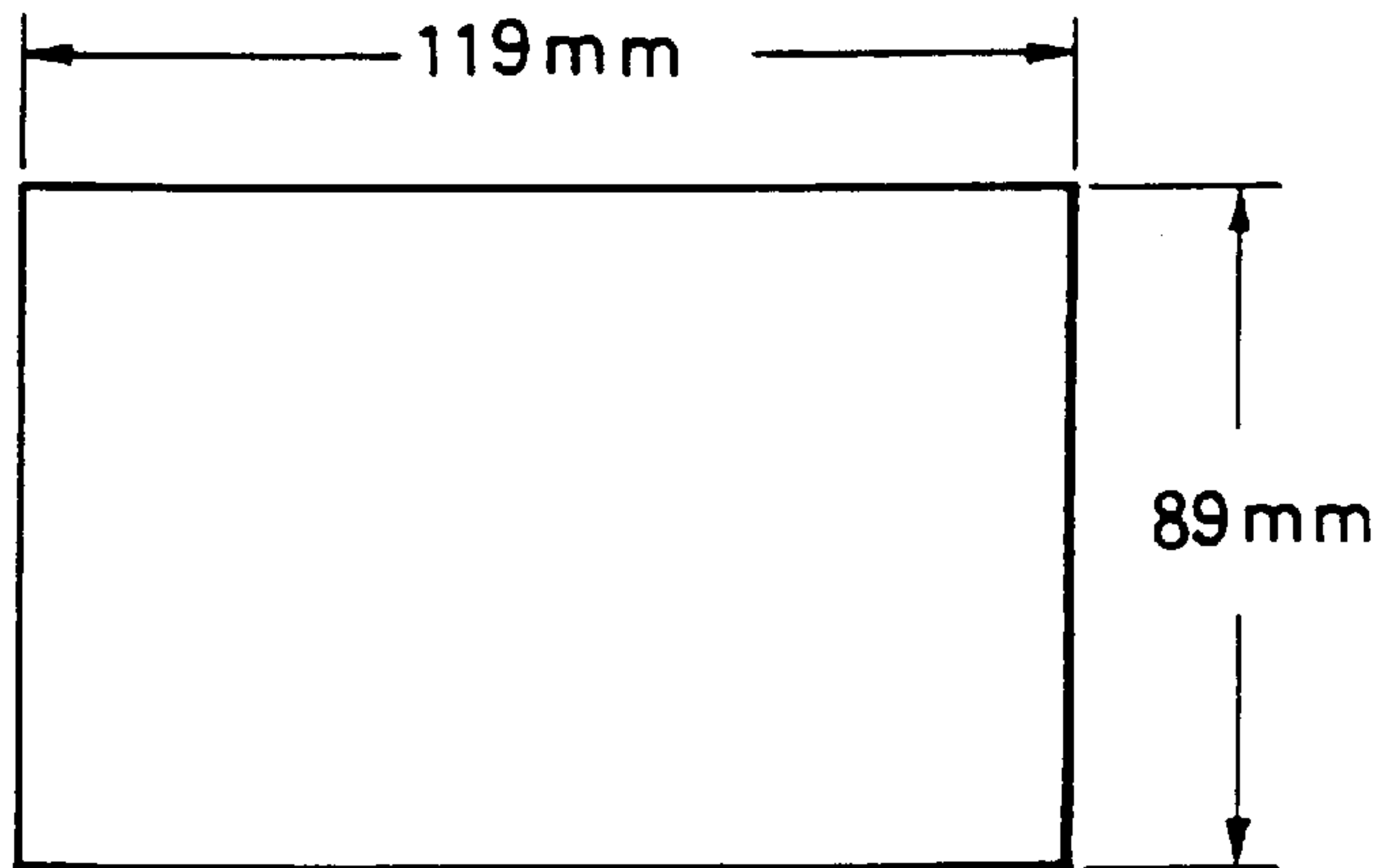

FIG. 20

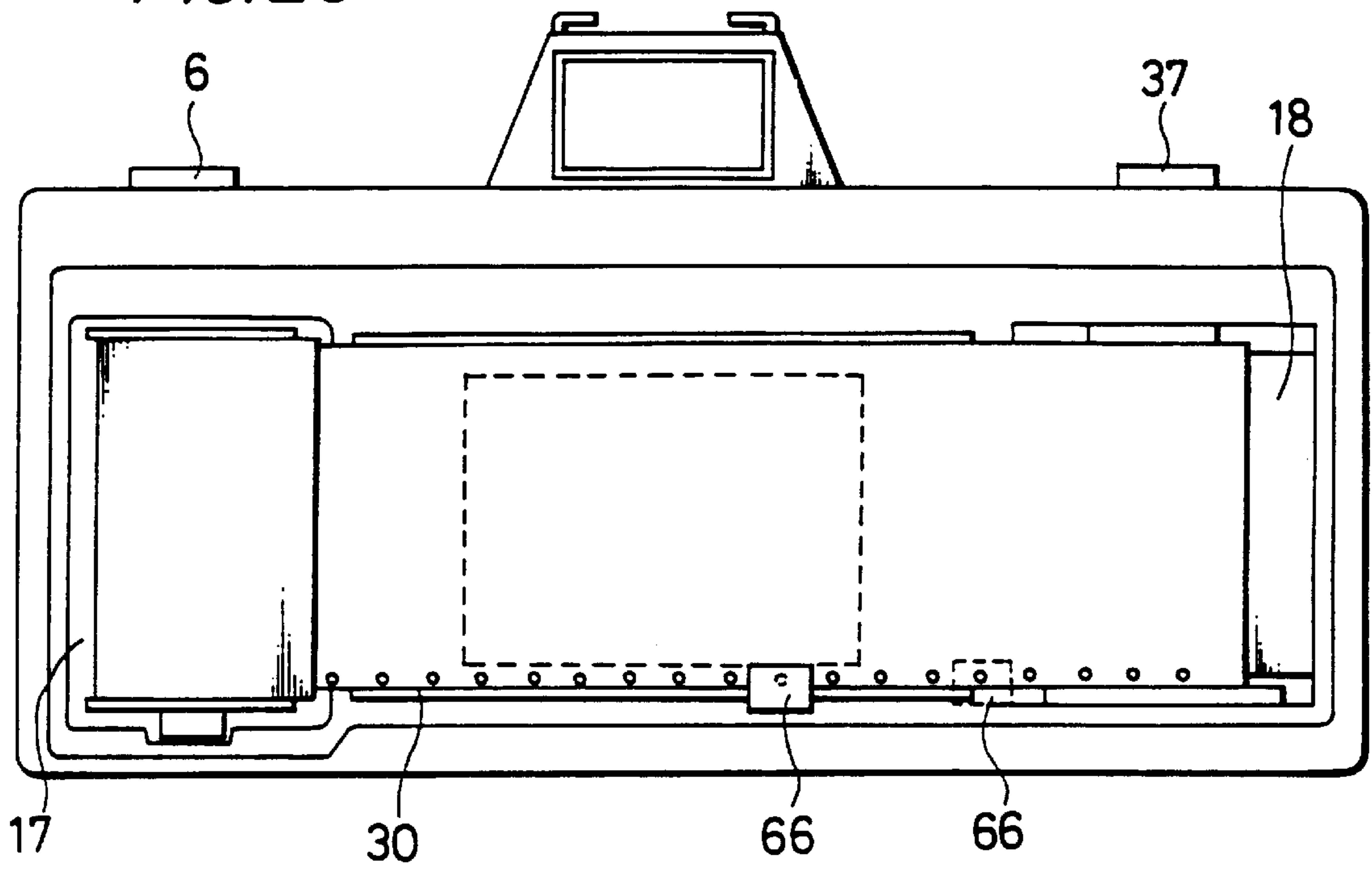
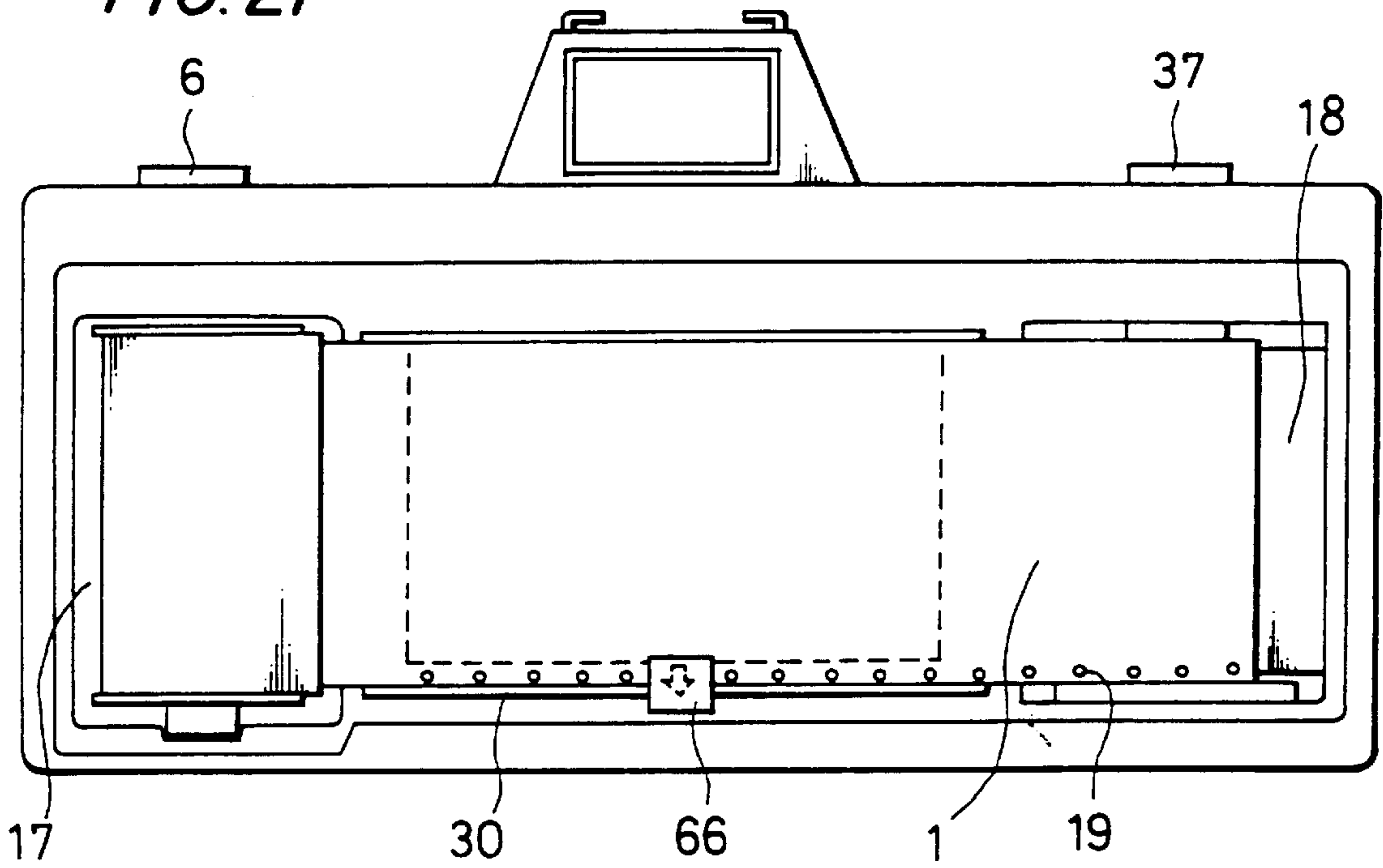

FIG. 21



PHOTOGRAPHIC CAMERA SYSTEM

Matter enclosed in heavy brackets [] appears in the original patent but forms no part of this reissue specification; matter printed in italics indicates the additions made by reissue.

BACKGROUND OF THE INVENTION

This is a continuation-in-part application of application Ser. No. 08/026,415 filed Mar. 4, 1993, now abandoned.

FIELD OF THE INVENTION

The present invention relates to a photographic camera system for producing pictures having various frame sizes, and more particularly to a photographic camera using a specialized photographic film and a film printing device for printing the processed photographic film having a succession of frames of different sizes that have been photographed by the camera.

DESCRIPTION OF THE BACKGROUND

The photographic film that is in the most widespread use today is 35-mm film (system 135) as provided for by Japanese Industrial Standards (JIS) and International Organization of Standardization (IOS).

U.S. Pat. No. 5,049,908 describes a photographic camera and a film therefor, with the film being of a 35-mm size devoid of sprocket holes of the size used in present 35-mm films and having an effective image area of about 30 mm across the film, thereby providing an increased effective usable film area.

More specifically, ignoring dimensional tolerances, present 35-mm films for use in general photography have a width of 35 mm between opposite longitudinal edges and include a series of film-transport perforations or sprocket holes defined along the opposite longitudinal edges of the film. The film-transport perforations are spaced 25 mm across the film and have a pitch of 4.75 mm. Frames on such a present 35-mm film are of a rectangular shape having a width of 25 mm across the film and a length of 36 mm along the film. The frames have a pitch of 38 mm, which is eight times larger than the pitch of the film-transport perforations.

As described in U.S. Pat. No. 5,049,908, some modern photographic film cameras are electronically controlled to provide motor-driven operation with high accuracy, and it has been experimentally confirmed that the film can be transported quite accurately without requiring the large sprocket wheels and film perforations that are found in most present cameras and films. In the system described in U.S. Pat. No. 5,049,908, the film-transport perforations are not present in the 35-mm photographic film, thereby increasing the available frame width across the film up to the regions where such film-transport perforations were located. The proposed film thus has an increased effective image area for improved image quality. This patent describes four sizes that are available for frames that can be exposed on a 35-mm film free of film-transport perforations.

According to one size, a frame that can be exposed in an effective image area of the 35-mm film has a width of 30 mm across the film and a length of 40 mm along the film. The frames of such a size have a pitch of 42.0 mm, for example. The frame size and pitch are selected to match specifications of the present television broadcasting system, for example, the NTSC system. Therefore, the frames have an aspect ratio of 3:4.

Another frame size described in that patent is based on High-Definition Television (HDTV) specifications, in which frames have a width of 30 mm and a length of 53.3 mm and a pitch of 57.75 mm, for example. The aspect ratio of the frames having that size is 9:16.

The above-mentioned frame sizes are full-frame sizes, and the other two frame sizes are half-frame sizes. According to one of the half-frame sizes, frames have a width of 30 mm and a length of 22.5 mm and a pitch of 26.2 mm, for example, to match present television broadcasting system specifications. According to the other half-frame size, frames have a width of 30 mm and a length of 16.9 mm and a pitch of 21.0 mm, for example, to match HDTV specifications.

Film with the above four frame formats is stored in the same film cartridge as presently available 35-mm film.

Because the frames in either of the above frame formats have a width of 30 mm, there are unexposed areas of about 2.5 mm between the frames and along the opposite longitudinal edges of the film. These unexposed areas may be used to keep the film flat, control the film, and write and read data when taking pictures.

The proposed camera may be relatively small and lightweight, because it does not require film-transport sprocket wheels.

Films that are actually collected in processing laboratories are processed either simultaneously in a batch or individually. In a simultaneous batch process, several thousand films are processed per hour at a high rate to realize economics of scale for reducing the printing cost. Specifically, a plurality of exposed films are collected in the processing laboratory and are spliced end to end to form a long, continuous film strip, which is then stored in a film magazine and subsequently processed.

If the films that are spliced into the continuous strip contain frames exposed in different frame formats, such as disclosed in U.S. Pat. No. 5,049,908, then the long single film stored in the film magazine contains different frame sizes, thereby making printing a problem.

U.S. Pat. Nos. 4,384,774 and 5,066,971 propose cameras capable of switching between half and full frame sizes at the time the film is exposed. When film exposed using these proposed cameras is spliced into a long, single, film strip for simultaneous batch processing, the continuous film strip also contains different frame sizes.

The processing laboratories are therefore required to form notches indicative of frame centers for automatically printing spliced films with different frame sizes after they are developed. For example, as disclosed in U.S. Pat. No. 4,557,591, a human operator manually notches a side edge of a spliced film and, hence, the notches are required to control the feed of the film. With the disclosed process, it is impossible to process several thousand films per hour, however, the cost of processing exposed film is relatively high. As a consequence, films with different frame sizes may not be accepted by processing laboratories in Japan.

Many processing laboratories all over the world also do not accept films with frames exposed in half size because they do not want different frame sizes to be contained in a single spliced film that is stored in a single film magazine for subsequent processing and printing. This problem arises because the different frame sizes can be recognized only after the film has been developed. One solution would be to apply marking seals to exposed films so that the films of different frame sizes thereof can be distinguished and sorted out for individual processing and printing. Nevertheless, use

of marking seals would not essentially solve the problem, because it would be difficult to supply such marking seals consistently over a number of years.

OBJECTS AND SUMMARY OF THE INVENTION

Accordingly, it is an object of the present invention to provide a variable frame size photographic system that can eliminate the above-noted drawbacks inherent in prior proposed systems.

It is another object of the present invention to provide a photographic camera that can expose a photographic film in different frame sizes as desired.

Another object of the present invention is to provide a photographic film printer for automatically printing successive photographic films, even if they contain different frame sizes.

According to one aspect of the present invention, there is provided a photographic camera system including a photographic camera having a camera body, a first housing disposed in the camera body for housing a photographic film cartridge, a second housing disposed in the camera body for housing a photographic film drawn from the photographic film cartridge, a film feed device disposed in the camera body for feeding the photographic film between the first and second housings, an exposure device disposed in the camera body for exposing an exposure area of the photographic film fed by the film feed device to an image of a subject between the first and second housings, and a recording device disposed in the camera body for optically or magnetically recording an exposure position control signal indicative of a position where the photographic film is to be exposed by the exposure device on the photographic film. The photographic camera system also includes a photographic film printer having a printer body, a detecting device disposed on the printer body for detecting the exposure position control signal that was optically or magnetically recorded on the photographic film, a film feed control device disposed on the printer body for controlling feeding of the photographic film based on the exposure position control signal detected by the detecting device, and a printing device disposed on the printer body for varying an opening width of a mask that is used to print the image of the subject in the exposure area of the photographic film on a print paper, depending on the exposure position control signal.

According to another aspect of the present invention, there is also provided a photographic camera including a first housing for housing a photographic film cartridge, a second housing for housing a photographic film drawn from the photographic film cartridge, a film feed device for feeding the photographic film between the first and second housings, an exposure device for exposing an exposure area of the photographic film fed by the film feed device to an image of a subject, and a recording device for optically or magnetically recording an exposure position control signal indicative of a position where the photographic film is to be exposed by the exposure device on the photographic film.

In another aspect the present invention provides a photographic camera including a camera body, a first housing disposed in the camera body for housing a photographic film cartridge, a second housing disposed in the camera body for housing a photographic film drawn from the photographic film cartridge, a film feed device disposed in the camera body for feeding the photographic film between the first and second housings, an exposure device disposed in the camera body for varying a width in which the photographic film is

exposed to an image of a subject in a direction in which the photographic film is fed by the film feed device, between the first and second housings, and a control unit disposed in the camera body for controlling the film feed device to feed the photographic film for a length corresponding to an increase in the width, at least when the width of the frame is increased.

The present invention in another aspect also provides a photographic film printer including a printer body, a detecting device disposed on the printer body for detecting an exposure position control signal that was optically or magnetically recorded on a photographic film, a film feed control unit disposed on the printer body for controlling feeding of the photographic film based on the exposure position control signal detected by the detecting device, and a printing device disposed on the printer body for varying an opening width of the mask that is used to print an image of a subject in an exposure area of the photographic film on a print paper, depending on the exposure position control signal.

The above and other objects, features, and advantages of the present invention will become apparent from the following description of illustrative embodiments thereof to be read in conjunction with the accompanying drawings, in which like reference numerals represent the same or similar objects.

BRIEF DESCRIPTION OF THE DRAWINGS

FIG. 1 is a fragmentary front elevational view of a 35-mm film that has been exposed using a 35-mm photographic camera according to an embodiment of the present invention;

FIG. 2 is a fragmentary front elevational view of another 35-mm film that has been exposed using an embodiment of the 35-mm photographic camera of the present invention;

FIGS. 3A and 3B are elevational views of 35-mm film cartridges that can be used in one embodiment of the 35-mm photographic camera of the present invention;

FIGS. 4A and 4B are elevational views of 35-mm film cartridges that can be used in another embodiment of the 35-mm photographic camera of the present invention;

FIG. 5 is a rear elevational view of the 35-mm photographic camera of one embodiment of the present invention with a rear lid removed;

FIG. 6 is an elevational view of an inner surface of a rear lid of the 35-mm photographic camera of FIG. 5;

FIG. 7 is a cross-sectional view taken along line VII—VII of FIG. 5;

FIG. 8 is a block diagram of a control system for one embodiment of the 35-mm photographic camera according to the present invention using the film of FIGS. 3A and 3B;

FIG. 9 is a rear elevational view of the 35-mm photographic camera of another embodiment of the present invention with the rear lid removed;

FIG. 10 is an enlarged fragmentary view of a portion of the camera shown in FIG. 7;

FIGS. 11A through 11E are fragmentary front elevational views showing the positional relationships of frames exposed on a 35-mm film using the embodiment of the 35-mm photographic camera according to the present invention;

FIG. 12 is a block diagram of a control system for the other embodiment of the 35-mm photographic camera according to the present invention using the film of FIGS. 4A and 4B;

FIG. 13 is an elevational view of an automatic printer for printing on photosensitive paper a processed 35-mm film that was exposed using the embodiment of the 35-mm photographic camera according to the present invention;

FIG. 14 is a block diagram of a control system used in the embodiment of the automatic printer shown in FIG. 13;

FIG. 15 is a block diagram of a control system for another embodiment of the printer according to the present invention;

FIGS. 16A and 16B are fragmentary front elevational views showing the relationship between a 35-mm film and sensors in the automatic printer shown in FIG. 13;

FIG. 17 is a flowchart of an operating method that is performed by a microprocessor of the control system shown in FIG. 14;

FIGS. 18A and 18B are representative of the relative sizes of negative-carrier variable slits in the automatic printer;

FIGS. 19A and 19B are representations showing the relative sizes of variable paper masks in the automatic printer;

FIG. 20 is a rear elevational view of a 35-mm photographic camera with a rear lid removed, according to another embodiment of the present invention; and

FIG. 21 is a rear elevational view of a 35-mm photographic camera with a rear lid removed, according to still another embodiment of the present invention.

DETAILED DESCRIPTION OF PREFERRED EMBODIMENTS

A 35-mm photographic film 1 that can be used in a 35-mm photographic camera according to the present invention is described with reference to FIGS. 1, 2, 3A, and 3B, in which FIGS. 1 and 2 show 35-mm photographic film 1 after it has been exposed, and FIGS. 3A and 3B show 35-mm photographic film 1 before being exposed.

As shown in FIGS. 3A and 3B, the 35-mm photographic film 1 is stored in a film cartridge 16 and has an end extending out of the film cartridge 16. Images that are photographed on the 35-mm photographic film 1 are turned upside down by the lenses, so that the upper end of an image is positioned on a lower portion of the photographic film 1. FIG. 3B shows by way of example a photographed image of a subject in broken lines, which appears to be turned upside down on the photographic film 1.

Each of the photographic films 1 shown in FIGS. 1, 2, 3A, and 3B has a series of film position detecting holes 19 defined along an unexposed marginal edge area thereof, which has a width of about 2.5 mm. This unexposed marginal area is used to control the film, to read data, and to write data when taking a picture. The film position detecting holes 19 have a diameter of about 1 mm and are spaced at a constant, predetermined pitch. The pitch of the film position detecting holes 19 in the photographic film 1 shown in FIG. 1 is 5.25 mm, for example, and the pitch of the film position detecting holes 19 in the photographic film 1 shown in FIG. 2 is 6.28 mm.

The film position detecting holes 19 can be replaced by magnetic marks 19' spaced at a predetermined constant pitch and made by a suitable magnetic head on a magnetic edge portion 19" formed on the unexposed film. The magnetic marks 19' are shown as broken lines on the magnetic strip 19" in FIGS. 4A and 4B, because they are not actually visible. Alternatively, the marks 19' could be formed as small dots of magnetic material, such as iron oxide, deposited on the unexposed film and detected by the magnetic head.

Distances by which the different photographic films 1 with the film position detecting holes 19 or magnetic marks 19' spaced at the pitches of 5.25 mm and 6.28 mm are advanced to feed frames of different frame sizes are given in Table 1 below.

TABLE 1

Frame sizes (Width × length)	Pitch - 6.28 mm	Pitch = 5.25 mm
NTSC-matched frame size (30 mm × 40 mm), full size	43.96 = 6.28 × 7 pitches	42.0 = 5.25 × 8 pitches
HDTV-matched frame size (30 mm × 53.3 mm), full size	56.52 = 6.28 × 9 pitches	57.75 = 5.25 × 11 pitches
HDTV-matched frame size (30 mm × 16.9 mm), half size	18.84 = 6.28 × 3 pitches	21.0 = 5.25 × 4 pitches
NTSC-matched frame size (30 mm × 22.5 mm), half size	25.12 = 6.28 × 4 pitches	26.25 = 5.25 × 5 pitches

The photographic film 1 shown in FIG. 3A has film position detecting holes 19 that will be positioned along an upper marginal edge area after the photographic film is exposed, however, no tongue is provided at the leading end, so that no tongue-removing process will subsequently be required. Because no tongue-removing process will be required, the subsequent processing of the photographic film 1 is less costly. This applies to the film shown in FIG. 4A as well.

The photographic film 1 shown in FIG. 3B also has film position detecting holes 19 that will be positioned in an upper marginal edge area thereof after the photographic film is exposed, and has a tongue at its leading end on its lower portion. The tongue at the leading end of the photographic film 1 is vertically opposite in position to the tongue of an ordinary 35-mm photographic film that is now generally commercially available. If a photocoupler is used in a photographic camera for detecting the film position detecting holes 19, then when the photographic film 1 is loaded into the photographic camera, the marginal edge with the film position detecting holes 19 is not required to be manually inserted into the photocoupler, but is automatically inserted into the photocoupler when the photographic film 1 is wound by a film transport mechanism in the photographic camera. This also applies to the film shown in FIG. 4B.

An embodiment of a photographic camera that can use the photographic films 1 shown in FIGS. 1, 2, 3A, and 3B is shown and described with reference to FIGS. 5 through 8 and 10. FIG. 5 is a rear elevation of the photographic camera with the rear lid or cover removed. The lid is shown in FIG. 6. The photographic camera has a dark box 4 including a cartridge housing 17 for housing the film cartridge 16, which is of a known structure, an exposure opening 7 near the cartridge housing 17 and through which the photographic film 1 can be exposed to light passing through a camera lens, aperture, and shutter not shown in FIG. 5, and a film housing 18 for housing the photographic film 1 after it has been exposed.

The photographic film 1 that is unwound from the film cartridge 16 housed in the cartridge housing 17 is fed over the exposure opening 7 while being transversely limited in motion by upper and lower respective pairs of film guides 30, 31, and is then moved into the film housing 18 after being exposed.

The film housing 18 has a guide roller 32 for automatically setting or loading the photographic film 1, and a film

takeup spool **9** rotatable by a motor, shown at **10** in FIG. **8**, for winding the exposed photographic film **1** thereon.

The photographic camera has a light-emitting diode (LED) **5a** positioned between the lower film guides **30**, **31** for detecting the film position detecting holes **19**, and a photodetector, shown in FIG. **6** at **5b**, disposed on a pressure plate of the rear lid and positioned in registry with the LED **5a** across the photographic film **1**. The photodetector **5b** has a diameter of 1.5 mm, for example.

The LED **5a** emits infrared radiation having a wavelength of 940 nm, which is different from those radiation wavelengths to which the photographic film **1** is sensitive. Referring to FIG. **8**, the LED **5a** and the photodetector **5b** jointly make up a hole sensor **5** that applies an output signal to a counter in a system controller **8** that comprises a microcomputer. In this way, the system controller **8** can recognize the position of the photographic film **1** over the exposure opening **7**. The LED **5a** and the photodetector **5b** may be alternatively replaced with a photocoupler that also comprises an LED and a photodetector but which are positioned in confronting relationship, as described hereinbelow.

Alternatively, as shown in FIG. **9** the LED **5a** can be replaced by a magnetic head **5c** that operates to sense the magnetic marks **19'**, shown in FIGS. **4A** and **4B**, that are on the marginal edge area **19''** of the unexposed film.

In FIG. **5**, the exposure area opening **7** has its size defined by left and right movable masks **15** that are laterally movable over the width of the exposure opening **7** from opposite sides thereof. The size of the exposure opening **7** in the longitudinal direction of the photographic film **1** can selectively be changed to four different dimensions of 53.33 mm, 40.00 mm, 22.5 mm, and 16.90 mm as indicated by the four pairs of broken lines in FIG. **5**.

As shown in FIGS. **7** and **10**, the left and right movable masks **15** are retractable into left and right side walls, respectively, that are positioned on opposite sides of the exposure opening **7** and extend substantially perpendicularly to the photographic film **1** as it extends over the exposure opening **7**. As shown in FIG. **8**, two linear toothed bars **33** are attached to the respective lower edges of the movable masks **15** and held in mesh with respective drive feed gears **34** of a gearbox **35**, much like a rack and pinion assembly. When the gears **34** of the gearbox **35** are driven to rotate the linear toothed bars **33**, and hence the movable masks **15**, are linearly moved over the exposure opening **7**.

As shown in FIGS. **5** and **7**, the photographic camera has a frame size setting switch **6** which can manually be turned by the user of the camera to produce a command signal indicative of a selected frame size which is one of the frame sizes described above in Table 1. When the user selects a frame size with the frame size setting switch **6**, the frame size setting switch **6** applies a command signal to the system controller **8**, which then supplies a control signal to achieve the desired frame size through a stepping motor driving circuit **13** to a stepping motor **14**. The stepping motor **14** is energized to rotate the feed gears **34** to move the movable masks **15**. At the same time that the movable masks **15** move, the hole sensor **5** produces and supplies a detected film position signal to the system controller **8**, which processes the supplied film position signal to generate a control signal. The system controller **8** then supplies the control signal through an amplifier **36** to a motor **10**, which rotates the film spool **9** to take-up the photographic film **1** over a predetermined length.

At this time, the length over which the photographic film **1** is driven corresponds to the distance that is determined by

the frame size setting switch **6**. The feeding of the photographic film **1** is described below with reference to FIGS. **11A** through **11E**, which show examples in which the hole pitch is 6.28 mm and the photographic film **1** is to be exposed in an HDTV-matched full-frame size of 30 mm×53.3 mm and an NTSC-matched full-frame size of 30 mm×40 mm.

FIG. **11A** shows a portion of the photographic film **1** as it is exposed in successive NTSC-matched full frames. When the photographic film **1** is fed for seven pitches of the holes **19**, a frame area of 30 mm×40 mm is made available for exposure through the exposure opening **7**. To switch from an NTSC-matched full-frame size to an HDTV-matched full-frame size, the photographic film **1** is fed for eight pitches of the holes **19**, as shown in FIG. **11B**, to make a frame area of 30 mm×53.3 mm available for exposure through the exposure opening **7**. To expose the photographic film **1** in successive HDTV-matched full frames, the photographic film **1** is fed for nine pitches of the holes **19**, as shown in FIG. **11C**, to make a frame area of 30 mm×53.3 mm available for exposure through the exposure opening **7**. To switch from an HDTV-matched full-frame size to an NTSC-matched full-frame size, the photographic film **1** is fed for eight pitches of the holes **19**, as shown in FIG. **11D**, to make a frame area of 30 mm×40 mm available for exposure through the exposure opening **7**.

To change frame sizes, the system controller **8** controls the motor **10** as follows: When switching from an NTSC-matched full-frame size to an HDTV-matched full-frame size, the photographic film **1** is first driven for seven pitches of the holes **19** and is then driven for one additional hole pitch. When switching from an HDTV-matched full-frame size to an NTSC-matched full-frame size, the photographic film **1** is first driven forward for nine pitches of the holes **19** and is then driven backward for one pitch.

When changing frame sizes, the photographic film **1** may be driven for a different distance or a different number of pitches, such as ten pitches of the holes **19**, as shown in FIG. **11E**. In this manner, the photographic film **1** may be easily exposed in many different frame sizes.

As shown in FIGS. **11A** through **11E**, the system controller of the photographic camera controls the feeding of the photographic film **1** such that the photographic film **1** will not be exposed in overlapping frames, even when different frame sizes are exposed.

The procedure described in relation to FIGS. **11A**–**11E** applies equally to the magnetic marks **19'** present on the film shown in FIGS. **4A** and **4B**.

FIGS. **1** and **2** illustrate the photographic film **1** whose effective exposure areas have been exposed in frames **3** of different sizes. In FIG. **1**, the photographic film **1** has been exposed in an HDTV-matched full-frame size, having a width of 30 mm, a length of 53.3 mm, and aspect ratio of 9:16, and in an NTSC-matched full-frame size, having a width of 30 mm, a length of 40 mm) whose aspect ratio is 3:4. The holes **19** defined along the upper marginal edge of the photographic film **1** have a pitch of 5.25 mm.

In FIG. **2**, the photographic film **1** has also been exposed in an HDTV-matched full-frame size and an NTSC-matched full-frame size, however, unlike FIG. **1**, the holes **19** defined in the upper marginal edge of the photographic film **1** have a pitch of 6.28 mm. In FIG. **2**, one frame of an HDTV-matched full-frame size corresponds to nine pitches of the holes **19**, and one frame of an NTSC-matched full-frame size corresponds to seven pitches of the holes **19**. Since these pitches are odd-numbered, a hole **19** may be positioned in

alignment with the center of the frame, so that the center of the frame can easily be detected.

As shown in FIGS. 5 and 8, the photographic camera has a shutter release button 37. When the shutter release button 37 is depressed, the system controller 8 controls the size of the exposure area and supplies a control signal to a mark recording circuit 38 for recording a central mark, a so-called effective exposure area position signal, indicative of the center of the frame 3 and also supplies a control signal to a frame number recording circuit 39 for recording a frame number. The mark recording circuit 38 energizes an LED 40 positioned at the lower film-guide pair 30, 31 for recording a central mark 40a, shown in FIGS. 1 and 2, representing the center of the exposed frame 3. The frame number recording circuit 39 energizes an LED 41 positioned at the lower film guide pair 30, 31 for recording a frame number 41a, shown in FIGS. 1 and 2, representing the frame number of the exposed frame 3. The frame number 41a can be recorded such that it agrees with an actual frame number.

Alternatively, as shown in FIG. 12 in place of LED 40 a magnetic head 40' can be employed to record the center mark on the marginal area 19" on the unexposed film. Similarly, the frame number can be recorded using another magnetic head 41'.

The system controller 8 also supplies a control signal to a frame size recording circuit 11 for recording a frame size signal, a so-called effective exposure area width signal, indicative of the frame size of the exposed frame 3. The frame size recording circuit 11 energizes an LED 12 positioned at the lower film guide pair 30, 31 for recording a frame size signal 12a, shown in FIGS. 1 and 2.

Alternatively, as shown in FIG. 12, in place of LED 12 a magnetic head 12' can be employed to record the frame size signal on the marginal area 19" on the unexposed film.

The magnetic head 5c that senses the magnetic marks 19' on the film shown in FIGS. 4A and 4B is connected to the system controller 8 through a buffer amplifier 5d or a similar playback amplifier.

The LED 12 may be composed of four LED elements which are selectively energized to record one of the frame size signals 12a, which represent the frame size set by the frame size setting switch 6. The various frame size signals 12a are shown by way of example in Table 2 below.

TABLE 2

Frame Size	Frame size signal 12a
HDTV-matched full-frame size	
NTSC-matched full-frame size	
NTSC-matched half-frame size	
HDTV-matched half-frame size	

The central mark 40a and the frame size signal 12a supply information regarding the frame position and the frame size to an automatic printer, described hereinbelow, for controlling the automatic printer when the exposed and processed film is printed.

While frame sizes can be recognized by measuring the distances between adjacent central marks a when the exposed film is printed, the processing speed of the automatic printer can be increased by using the frame size signal 12a.

At the same time that the photographic film 1 is exposed, the system controller 8 supplies an information signal to an information recording circuit 42 for recording desired information. The information recording circuit 42 energizes an

LED 43 positioned at the upper film guide pair 30, 31 for recording such information 43a on the lower marginal edge, shown in see FIGS. 1 and 2, of the photographic film 1. The information 43a may be information that is supplied from the camera lens and the camera itself upon exposure or could consist of the exposure date, the person who took the picture, an exposure condition, or other information that the user has entered through an input device 44, such as a keypad, on the outer surface of the rear lid of the camera body 10. The amount of information 43a, that is, the number of characters that can be recorded, is dependent upon the frame size, and is displayed on a display panel 44a of the input device 44. The LED 43 has a number of LED elements that are selectively energized depending on the frame size.

An analysis has been made to determine the optimum position where the information 43a should be recorded and the optimum position where the holes 19 or magnetic marks 19' are defined from the standpoints of the user's convenience and a psychological effect that those positions have on the user. The results of the analysis are as follows:

(1) If marginal edges outside of the effective exposure area of the film are available as a band for recording user's information, then the information should more preferably be positioned on the lower marginal edge of the print paper, rather than on the upper marginal edge.

(2) Study of the developing and printing processes in processing laboratories indicates that in many cases information about the film itself is printed in many cases on film negatives, such that the film information will be positioned on the upper marginal edge of the print paper. It is preferable not to mix the film information and the band for recording user's information.

From the above results, it is preferable to position the film position detecting holes 19 upwardly of the effective exposure area of the film when it is exposed.

As described above with reference to FIGS. 5 through 8, the photographic camera according to the present invention has a detecting means 5a, 5b for detecting the feeding of the photographic film 1, a film control system 8, 9, 10 for controlling the distance by which the photographic film 1 moves and for driving the photographic film 1 for a length corresponding to the width of the selected exposure opening 7, based on a detected signal from the detecting means 5a, 5b, and for controlling a signal recording device 8, 11, 12, 38, 40 disposed near the exposure opening 7 for recording a signal indicative of the position of the exposure opening 7 on the photographic film 1 when the photographic film 1 is exposed through the exposure opening 7.

After the photographic film 1 is exposed using the photographic camera, the processed photographic film 1 bears control signals that are recorded in a signal recording area 21, shown in see FIG. 1, thereof and that will be used when the photographic film 1 is printed. Therefore, even if the developed photographic film 1 contains frames of different frame sizes, it can be automatically printed by an automatic printer without requiring individual adjustment.

The photographic camera according to the present invention also has a film control system 8, 9, 10 for controlling the feeding or driving of the photographic film 1, and an opening control system 8, 13, 14, 15 for varying the width of the exposure opening 7 along the photographic film 1. At least when the width of the exposure opening 7 changes from a smaller dimension to a larger dimension, the film control system 8, 9, 10 drives the photographic film 1 for a length corresponding to the selected width of the exposure opening 7.

Therefore, the width of the exposure opening 7 is variable, and the take-up or driving of the photographic film 1 is controlled depending on the width of the exposure opening 7. The photographic camera can expose the photographic film 1 successively in desired frame sizes which may differ one from another without adjacent frames overlapping each other.

As shown in FIG. 1, the photographic film 1 used in the photographic camera according to the present invention has a signal recording area 21 located between an effective exposure area 20 and a marginal edge thereof for magnetically or optically recording control signals, which will be used when the photographic film 1 is processed and printed. The film 1 has holes 19 or magnetic marks 19' defined in an upper marginal edge area thereof between the effective exposure area 20 and the marginal edge for detecting the distance by which the photographic film 1 has been moved.

As shown in FIG. 13, an automatic printer for automatically printing processed photographic film 1 that has been exposed using a camera as described above has a printer body that supports a paper supply reel 45 for supplying the sensitized print paper 46, a paper deck or platen 47 for supporting the print paper 46 supplied from the paper supply reel 45, a variable paper mask 48 for determining the size of a print paper segment on which an image is to be printed, a paper holder plate 49 for holding the print paper 46 down against the paper deck 47, a paper feed or drive roller 50 for driving the print paper 46, and a paper takeup reel 51 for winding the exposed print paper 46.

The printer body of the automatic printer also supports a film supply reel 52 for supplying the processed photographic film 1, a film deck or platen 53 for supporting the photographic film 1 supplied from the film supply reel 52, a negative-carrier variable slit 54, a negative holder plate 55 for positioning the negative down against the film deck 53, a film feed or drive roller 56 for driving the photographic film 1, a film takeup reel 57 for winding the exposed and processed photographic film 1, a lens 58 positioned above the negative holder plate 55, a bellows 59 supporting the lens 58 and positioned below the paper deck 47, a lamp 60 disposed below the film deck 53, a black shutter 61 positioned above the lamp 60, a filter assembly 62 composed of yellow, magenta, and cyan (Y, M, C) filters, and a diffusion box 63 disposed between the filter assembly 62 and the film deck 53.

The negative holder plate 55 supports a frame size sensor S1 for detecting the frame size signal 12a recorded on the photographic film 1 and a frame center sensor S2 for detecting the central mark 40a recorded on the photographic film 1 that indicates the center of a frame.

Upon detection of the central mark 40a of the frame 3 with the frame center sensor S2, the film drive roller 56 is controlled to drive the film to align the frame center with the center of the negative-carrier variable slit 54. The variable paper mask 48 and the negative-carrier variable slit 54 are controlled based on the frame size signal 12a that is detected by the frame size sensor S1.

If the frame size is an HDTV-matched frame size, for example, the negative-carrier variable slit 54 is set to dimensions as shown in FIG. 18A, and the variable paper mask 48 is set to dimensions as shown in FIG. 19A. If the frame size is an NTSC-matched frame size, for example, the negative-carrier variable slit 54 is set to dimensions as shown in FIG. 18B, and the variable paper mask 48 is set to dimensions as shown in FIG. 19B.

A control system for the automatic printer is shown in FIG. 14, in which the frame size sensor S1 and the frame

center sensor S2 comprise photocouplers, respectively, for detecting the frame size signal 12a and the central mark 40a, respectively, that are recorded in the marginal edge area of the photographic film 1.

On the other hand, the optical sensors S1 and S2 may be comprised of respective magnetic heads S1' and S2', as shown in FIG. 15, that read the frame size signal and the frame center signal that are magnetically recorded on the marginal area 19" of the unexposed film.

The frame center is determined based on the central mark 40a detected by the frame center sensor S2, and the frame size of the frame 3 whose frame center is determined by a microprocessor 64 of the control system based on the frame size signal 12a that is read by the frame size sensor S1 before the central mark 40a is detected by the frame center sensor S2. Then, the microprocessor 64 controls a mask size drive motor M3 to actuate the variable paper mask 48 to conform with the determined frame size. At the same time, the microprocessor 64 controls a negative-carrier variable slit drive motor M2 to actuate the negative-carrier variable slit 54.

Based on the frame size signal 12A read by the frame size sensor S1, the microprocessor 64 controls a film feed motor M1 to rotate the film feed roller 56 for feeding the photographic film 1 for a predetermined length. At the same time, the microprocessor 64 controls a paper feed motor M4 to rotate the paper feed roller 50 for thereby feeding the print paper 46 for a predetermined length.

FIGS. 16A and 16B show the relationship between the photographic film 1, the frame center sensor S2, and the frame size sensor S1 in the automatic printer. When the photographic film 1 is driven in the direction indicated by the arrow A in FIG. 16A, a frame size indicator 12a is detected by the frame size sensor S1 before its frame 3 is positioned and the sensor S1 output signal is used for controlling the driving of the photographic film 1, the negative-carrier variable slit 54, and the variable paper mask 48. The frame size signal from sensor S1 is processed by the microprocessor 64, which determines the frame size when the frame center of the frame 3 is determined by the frame center sensor S2.

As shown in FIGS. 16A and 16B, the central mark 40A indicative of a frame center is recorded at each frame on the photographic film 1. At each frame, the frame size indicator 12a is recorded ahead of the central mark 40a, and the frame number 41a is recorded behind the central mark 40a with respect to the direction in which the photographic film 1 is driven.

While the frame center sensor S2 and the frame size sensor S1 are shown as being located in substantially the same position, only the frame center sensor S2 should be positioned in alignment with the center of the negative-carrier variable slit 54 and the variable paper mask 48, and the frame size sensor S1 may be positioned on the film deck 53 at the entrance end thereof. This applies to the magnetic head sensors S1' and S2' as well.

FIG. 17 shows a control sequence of the microprocessor 64 for controlling the driving of the developed photographic film or negative 1 and the driving of the print paper 46. The negative-carrier variable slit 4 and the variable paper mask 48 are also controlled in this control sequence. The photographic film 1 is continuously driven and taken up until the central mark 40a is detected by the frame center sensor S2, and then the photographic film 1 is stopped when the central mark 40a is detected by the frame center sensor S2. Until the photographic film 1 is stopped, the frame size indicator 12a is detected by the frame size sensor S1 and its number is counted.

13

If the frame size indicator **12a** represents "3", the width of the negative-carrier variable slit **54** is set to 38 mm, and the width of the variable paper mask **48** is set to 119 mm. Thereafter, the print paper **46** is moved, and the photographic film **1** is printed, after which the control sequence is ended. The print paper **46** is moved for a distance corresponding to printed frame sizes, a blank surrounding the printed frames, and a cutting blank between the printed frames. Usually, a hole is defined in the cutting blank when the photographic film **1** is printed, and serves as a positional signal for automatically cutting the print paper.

If the frame size indicator **12a** represents "4", the width of the negative-carrier variable slit **54** is set to 51 mm, and the width of the variable paper mask **48** is set to 158 mm. Thereafter, the print paper **46** is moved, and the photographic film **1** is printed, after which the control sequence is ended.

If the frame size indicator **12a** represents "1" or "2", the widths of the negative-carrier variable slit **54** and the variable paper mask **48** are set similarly. Thereafter, the print paper **46** is moved, and the photographic film **1** is printed, after which the control sequence is ended.

Since the frame size indicator **12a** is recorded in the upper marginal edge portion of the photographic film **1**, it may possibly be recognized in error as the central mark **40a**. To avoid such an error, a negative feed sensor **S3**, shown in FIG. **14**, for detecting the distance by which the photographic film **1** is fed is associated with the film feed motor **M1**, and the distance by which the photographic film **1** is fed is measured by a counter **65** whose count is fed back to the microprocessor **64**. Since the width of the frame size indicator **12a** on the photographic film **1** can be detected by the distance by which the photographic film **1** is driven, the frame size indicator **12a** can be distinguished from the central mark **40a** or the frame number **41a**.

As described above with reference to FIGS. **13**, **14**, and **16A-16B**, the automatic printer according to the present invention has a film drive control device **65**, **64**, **M1** for detecting an effective exposure area position indicator **40a** recorded in a marginal edge area between the effective exposure area **20** on the photographic film **1** and the marginal edge thereof to control the driving of the photographic film **1**, and a printing opening width control device **54**, **64**, **M2** for detecting an effective exposure area width indicator **12a** recorded in the marginal edge area to control the width of the printing opening along the photographic film **1**.

The photographic film **1** has an effective exposure area position indicator **40a** and an effective exposure area width indicator **12a** which are recorded in a marginal edge area between the effective exposure area **20** on the photographic film **1** and the marginal edge thereof. After the effective exposure area width indicator **12a** has been detected, the effective exposure area position indicator **40a** is detected. The width of the film exposure opening along the photographic film **1**, the width of the print paper exposure opening, and the distance by which the print paper **46** is driven are controlled based on the detected effective exposure area width indicator **12a**, and the distance by which the photographic film **1** is fed is controlled based on the detected effective exposure area position indicator **40a**.

Therefore, since the distance by which the photographic film **1** is driven is controlled based on the effective exposure area position indicator **40a** recorded in the marginal edge area of the photographic film **1** and the width of the printing opening, the width of the print paper exposure opening and the distance over which the print paper **46** is driven are

14

controlled based on the effective exposure area width indicator **12a** recorded in the marginal edge area of the photographic film **1**, the photographic film **1** can automatically be printed even if it has a succession of frames of different sizes.

In the illustrated photographic camera, the LED **5a** and the photodetector **5b** are disposed in confronting relationship to each other for detecting the film position detecting holes **19**, however, as shown in FIGS. **20** and **21**, a photocoupler **66**, which is an integral combination of an LED and a photodetector for detecting a film position, may be disposed on a film guide **30**. The photocoupler **66** may be positioned anywhere on the film guide **30**. The photocoupler **66** may have LEDs **41**, **40**, as shown in FIG. **5**, for recording the frame number **41a** and the central mark **40a** at the same time that the frame is exposed.

While the hole sensor **5** comprises an LED and a photodetector in the illustrated photographic camera, the hole sensor **5** may comprise two pairs of an LED and a photodetector given the different distances by which frames of different sizes are fed.

In the illustrated automatic printer, the same photographic film contain frames of different sizes, however, the present invention is also applicable to an automatic printer for automatically printing a spliced length of photographic films with different frame sizes.

The present invention uses an exposure control signal magnetically or optically recorded between an edge of the photographic film and an effective exposure area of the photographic film. This signal can be used not only by the processor but also by the user, and the user can print by a simple printer system according to the present invention. This simple home system can be combined with a computer system or a television for display. Also, an exposure control signal of the present invention may include an auxiliary signal for controlling a printer system or indicating certain features to the user. Thus, the present invention as described above can be used for many applications because it avoids using the punched in notch required in previously proposed systems.

Having described preferred embodiments of the invention with reference to the accompanying drawings, it is to be understood that the invention is not limited to those precise embodiments and various changes and modifications could be effected by one skilled in the art without departing from the spirit or scope of the present invention, as defined in the appended claims.

What is claimed is:

1. A photographic system comprising:

- a photographic camera including
 - a camera body,
 - a first housing disposed in the camera body for housing photographic film in a photographic film cartridge,
 - a second housing disposed in the camera body for housing the photographic film drawn from the photographic film cartridge,
 - film drive means disposed in the camera body for driving the photographic film between the first and second housings,
 - control means disposed in the camera body including a micro-computer electrically connected to a selector switch operable by a user for receiving a selection signal from the selector switch and controlling an aspect of an effective area of the photographic film drawn from the photographic film cartridge, and
 - recording means disposed in the camera body and responsive to the micro-computer for magnetically

15

- recording at least an aspect signal between an edge of the photographic film and the effective area of the photographic film that indicates the aspect of the effective area where an exposed area on the photographic film is to be printed on photosensitive print paper; and
- a photographic film printer for printing on photosensitive print paper processed photographic film recorded using the photographic camera, the printer including
- a printer body,
 - a light source and variable width mask for exposing the photosensitive print paper,
 - detecting means disposed on the printer body for detecting the aspect signal magnetically recorded between the edge of the photographic film and the effective area of the photographic film by the photographic camera,
 - processed photographic film drive control means disposed on the printer body for controlling driving of the processed photographic film,
 - logic circuit means for determining if the aspect signal detected by the detecting means corresponds to a first aspect format or a second aspect format, and
 - printing means disposed on the printer body for varying an opening width of the variable width mask used to expose an image of a subject in the effective area of the photographic film onto the photosensitive print paper depending on the format determined by the logic circuit means.
2. A photographic system according to claim 1, wherein the control means includes means for varying the aspect of the effective area of the photographic film along a direction in which the photographic film is driven by the film drive means.
3. A photographic system according to claim 1, wherein the recording means includes means for generating an exposure area position signal and the aspect signal, and wherein the processed photographic film drive control means includes means for controlling driving of the photographic film in response to detecting the exposure area position signal, and the printing means includes means for varying the opening width of the variable width mask in response to detecting the aspect signal.
4. A photographic system according to claim 2, wherein the means for varying the aspect includes left and right movable masks mounted on the camera body for respective movement in the direction of film drive and opposite to that direction.
5. A photographic system according to claim 4, wherein the means for varying further includes linear gear elements affixed to ends of the left and right movable masks cooperating with respective rotary gears and motor means for rotating the rotary gears to drive the linear gear elements.
6. A photographic system according to claim 5, wherein the selector switch includes a frame signal setting switch for selecting at least two exposure area aspects, and wherein the motor means includes a stepper motor driver for driving the left and right movable masks to at least two predetermined positions corresponding to the at least two exposure area aspects.
7. A photographic system according to claim 1, wherein one of the first aspect format and the second aspect format includes a HDTV format having an aspect ratio of 9:16.
8. A photographic system according to claim 1, wherein the photographic film printer further comprises a film feed sensor for detecting a distance the processed photographic film is driven by the film drive control means, and the logic

16

- circuit means receives an output from the film feed sensor for determining that the detecting means correctly detected the aspect signal recorded on the processed photographic film.
9. A photographic camera comprising:
- a first housing for housing a photographic film cartridge containing a photographic film strip, *the photographic film strip having film positioning holes in a first marginal area thereof*;
 - a second housing for housing a photographic film strip drawn from the cartridge;
 - film feed means for feeding the photographic film strip between the first and second housings;
 - control means including a microcomputer electrically connected to a selector switch operable by a user [for controlling an aspect of an effective area on the photographic film strip,]; and[;]
 - recording means responsive to the micro-computer for magnetically recording *information input by the user, the information including an aspect signal recorded in a second marginal area of the photographic film strip opposite the first marginal area and between an edge of the photographic film strip and the effective area of the photographic film strip, the aspect signal corresponding to one of a plurality of aspect formats* indicating the aspect of the effective area [where an exposed area on the photographic film is] to be printed on photosensitive print paper, *wherein the first marginal area has film information pre-recorded thereon, and the plurality of aspect formats includes a format in which the aspect ratio of the effective area is 9:16 and a size of the effective area is 16.9 mm×30 mm, the 30 mm extending across a width of the film strip.*
10. A photographic camera according to claim 9 wherein the control means includes means for varying the aspect of the effective area of the photographic film along a direction in which the photographic film strip is fed by the film feed means.
11. A photographic camera according to claim 9, wherein the recording means includes means for producing the aspect signal that indicates the aspect of the effective area.
12. A photographic camera according to claim 11, wherein the recording means further includes means for producing an exposure area position indicating signal and an exposure area number indicating signal.
13. A photographic camera according to claim 10, wherein the means for varying an aspect includes left and right movable masks mounted on the camera body for respective movement in a direction of film drive and opposite to that direction.
14. A photographic camera according to claim 13, wherein the means for varying further includes linear gear elements affixed to ends of the left and right movable masks cooperating with respective rotary gears and motor means for rotating the rotary gears to drive the linear gear elements.
15. A photographic camera according to claim 9, wherein the recording means further includes means for producing information that is entered through an input device and recording the information in a marginal area on a side of the photographic film opposite to a side in which a film position detecting hole is formed.
16. A photographic camera according to claim 9, wherein the selector switch selects from [at least two aspect formats including a first aspect format and a second aspect format, and one of the at least two aspect formats includes a HDTV

17

format having an aspect ratio of 16:9] *the plurality of aspect formats including a format in which the aspect ratio of the effective area is 3:4 and the size of the effective area is 22.5 mm×30 mm.*

17. A photographic camera comprising:

a camera body;

a first housing disposed in the camera body for housing a photographic film cartridge containing a photographic film strip;

a second housing disposed in the camera body for housing the photographic film strip drawn from the photographic film cartridge;

film feed means disposed in the camera body for feeding the photographic film strip between the first and second housings;

exposure means disposed in the camera body for varying an aspect of an effective area where an exposed area on the photographic film is to be printed on photosensitive paper in a direction in which the photographic film strip is fed by the film feed means between the first and second housings;

control means disposed in the camera body for controlling the film feed means to feed the photographic film strip for a length corresponding to an increase in the aspect of the effective area at least when the effective area is increased so that effective areas of different aspects may coexist on the photographic film strip; and

recording means disposed in the camera body for magnetically recording an aspect signal along an edge of the photographic film for indicating the aspect of the effective area.

18. A photographic film printer comprising:

a printer body;

detecting means disposed on the printer body for detecting picture aspect information magnetically recorded on the photographic film in a marginal area between an edge of the photographic film and an effective area of the photographic film, wherein the picture aspect information indicates an aspect ratio of an exposure area on the photographic film to be printed on photosensitive paper;

film feed means disposed on the printer body for feeding the photographic film;

logic circuit means for determining if the detected picture aspect information is of a predetermined print format; and

printing means disposed on the printer body for varying an opening width of a mask which is used to print an image of a subject from the exposure area of the photographic film onto the photosensitive print paper depending on the determined print format,

wherein the picture aspect information is recorded in a marginal area of the photographic film between an edge of the photographic film and the exposure area of the photographic film, and the picture aspect information includes one of at least a HDTV format aspect ratio and a NTSC format aspect ratio.

19. A photographic film printer according to claim 18, wherein

the detecting means non-mechanically detects an exposure area position signal arranged in the marginal area, the film feed means includes means for feeding the photographic film depending on the exposure area position signal, and

18

the printing means includes means for varying the opening width of the mask based on the picture aspect information.

20. A photographic film printer according to claim 18, wherein the printing means includes means for feeding the photosensitive print paper for a length corresponding to an increase in the opening width at least when the opening width is increased.

21. A photographic film printer according to claim 18, further comprising a film feed sensor for detecting a distance the photographic film is fed independently of detecting the picture aspect information, and wherein a logic circuit means receives an output of the film feed sensor and determines whether the detecting means correctly detected the picture aspect information.

[22. A photographic camera comprising:

a camera body;

a first housing disposed in the camera body for housing a photographic film cartridge containing a photographic film strip;

a second housing disposed in the camera body for housing the photographic film strip drawn from the photographic film cartridge;

film feed means disposed in the camera body for feeding the photographic film strip between the first and second housings;

control means including a micro-computer, the control means electrically connected to a selector switch operable by a user for receiving a selection signal from the selector switch and for controlling an aspect of an effective area of the photographic film strip where an exposed area on the photographic film strip is to be printed on photosensitive print paper; and

recording means disposed in the camera body for electrically receiving an aspect signal from the control means and for recording the aspect signal between an edge of the photographic film strip and an effective exposure area of the photographic film strip, the aspect signal indicating the aspect of the effective area of the photographic film strip,

wherein the photographic film strip is devoid of any sprocket holes.]

[23. A photographic camera according to claim 22, wherein the recording means further includes means for producing an exposure condition signal.]

[24. A photographic camera according to claim 22, wherein the recording means further includes means for producing input information input by a user using an input device and for recording the input information in a marginal area of the photographic film strip that is devoid of any sprocket holes.]

[25. A photographic camera comprising:

a camera body;

a first housing disposed in the camera body for housing a strip of photographic film;

a second housing disposed in the camera body for housing the photographic film drawn from the first housing;

film feed means disposed in the camera body for feeding the photographic film between the first and second housings;

control means including a selector switch operable by a user for controlling an aspect of an effective area of the photographic film where an exposed area of the photographic film is to be printed on photosensitive print paper depending on a signal from the selector switch; and

recording means disposed in the camera body for electrically receiving the signal that indicates the aspect of the effect area of the photographic film from the control means and for recording the signal between an edge of the photographic film and an effective exposure area of the photographic film, the photographic film being devoid of any sprocket holes.]

26. A photographic film printer system comprising:

a printer body;

first means disposed on the printer body for generating a position control signal in response to an exposure position control signal magnetically recorded on a photographic film;

second means disposed on the printer body for generating a print size control signal in response to picture aspect information magnetically recorded on the photographic film;

film feed control means disposed on the printer body for controlling feeding of the photographic film based on the position control signal generated by the first means; and

printing means disposed on the printer body varying an opening width of a mask used to print an image of a subject in an exposure area of the photographic film on photographic print paper based on the print size control signal generated by the second means,

wherein the exposure position control signal and the picture aspect information are magnetically recorded within a marginal area of the photographic film between an edge of the photographic film and the exposure area of the photographic film.

27. A photographic film printer system according to claim **26**, wherein the first and second means respectively include first and second magnetic sensing means arranged on the printer body in alignment with the marginal area of the photographic film.

28. A photographic film printer system according to claim **26**, wherein the printing means includes print paper feeding means for feeding the photographic print paper, and wherein the mask is arranged to correlate with a path of the photographic print paper fed by the print paper feeding means.

29. A photographic film printer system according to claim **26**, further comprising opening width control means for varying an opening width of a slit aligned with a path of the photographic film, the opening width of the slit being controlled in response to the print size control signal.

30. A method for printing an image from processed photographic film onto photographic print paper, the method comprising:

feeding the processed photographic film in a predetermined direction;

magnetically detecting picture aspect information recorded on the processed photographic film;

detecting film information pre-recorded on the processed photographic film;

determining whether the picture aspect information is correct;

determining if an aspect ratio of a picture to be printed is of a first or a second frame format depending on the detected picture aspect information; [and]

varying an opening width of a mask used to print the image from an exposure area of the processed photographic film onto the print paper depending on the determined frame format; and

printing the image from the exposure area of the processed photographic film onto the photographic print paper based on the detected film information,

wherein the picture aspect information is magnetically recorded within a *first* marginal area of the processed photographic film along an edge of the processed photographic film, *and the pre-recorded film information is recorded within a second marginal area opposite the first marginal area.*

31. A method for printing an image according to claim **30**, wherein the picture aspect information is detected midway in the feeding of the processed photographic film.

32. A method for printing an image according to claim **30**, further comprising

detecting the feeding of the processed photographic film, and

determining if the picture aspect information is correct or incorrect depending on the detected feeding of the processed photographic film.

33. A method for printing an image according to claim **30**, wherein one of the first and second frame formats has an HDTV format type aspect ratio.

34. A method for printing an image according to claim **33**, wherein the HDTV format type aspect ratio is 16:9.

35. A method for printing an image according to claim **30**, wherein the step of varying includes:

a process to vary the opening width of the mask to a first frame size or a second frame size depending on the determined frame format, and

one of the first and second frame sizes has a dimension of 158 mm×89 mm.

36. A photographic film printer comprising:

a printer body;

detecting means disposed on the printer body for magnetically detecting picture aspect information recorded on photographic film when an exposure is made, the picture aspect information indicating an aspect ratio of an exposure area on the photographic film to be printed on photographic print paper;

film feed means disposed on the printer body for feeding the photographic film;

logic circuit means disposed on the printer body for determining if the aspect ratio is of a first or a second frame format depending on the picture aspect information; and

printing means disposed on the printer body for varying an opening width of a mask used to print an image of a subject from an exposure area of the photographic film onto the photographic print paper depending on the determined frame format, wherein

the picture aspect information is recorded within a marginal area of the photographic film along an edge of the photographic film, [and]

at least one of the first and said second frame formats has an HDTV format type aspect ratio, and

the logic circuit means determines if the picture aspect ratio information is correct or incorrect depending on film feed information received from the film feed means.

37. A photographic film printer according to claim **36**, wherein the printing means varies the opening width of the mask to a first frame size or a second frame size depending on the determined frame format, and one of the first and said second frame sizes has a dimension of 158 mm×89 mm.

38. A photographic film printer according to claim **36**, wherein the HDTV format type aspect ratio is 16:9.

39. A photographic film printer according to claim **36**, wherein the printing means varies the opening width of the mask along a film feed direction.

[40. A photographic film printer according to claim 36, wherein the film feed means includes a film feed detector for detecting feeding of the photographic film, and the logic circuit means determines if the picture aspect ratio information is correct or incorrect depending on film feed information received from the film feed detector.]

41. A photographic film printer according to claim 36, wherein the logic circuit means has at least two items of type-size information related to the picture aspect information, the type-size information being used to control the printing means to vary the opening width of the mask.

42. A photographic film printing system comprising:

film feeding means for feeding a processed photographed film in a first predetermined direction;

paper feeding means for feeding photographic print paper in a second predetermined direction,

said processed photographic film having an effective exposure area and a marginal area between the effective exposure area and an edge of the processed photographic film, wherein the marginal area has [arranged] recorded thereon a film position detecting signal and picture aspect information relating to the effective exposure area for each frame of the processed photographic film, *the film position detecting signal being optically or magnetically recorded, and the picture aspect information being magnetically recorded;*

detecting means disposed along a path of the processed photographic film fed by the film feeding means for magnetically detecting a picture aspect information;

film feed control means for controlling the film feeding means so as to stop the processed photographic film at predetermined positions; and

mask means having a variable opening width thereof used to print an image of a subject from the effective exposure area of the processed photographic film onto the photographic print paper, the opening width of the mask being controlled in response to the picture aspect information detected by the detecting means.

43. A photographic film printing system according to claim 42, further comprising variable opening slit means disposed along the path of the processed photographic film fed by the film feeding means, an opening width thereof being determined in response to the picture aspect information detected by the detecting means.

44. A photographic film printing system according to claim 42, wherein the picture aspect information corresponds to at least an HDTV format type aspect ratio or a NTSC format type aspect ratio, and the opening width of the mask means corresponds to at least the HDTV format type aspect ratio or the NTSC format type aspect ratio.

45. A photographic film printer comprising:

detecting means for magnetically detecting picture aspect information recorded [on] in a marginal edge area of a photographic film; [and]

means for determining whether the picture aspect information detected by the detecting means is correct; and printing format changing means for automatically changing a photographic area aspect according to the picture aspect information detected by the detecting means when the picture aspect information is determined to be correct,

wherein the photographic area aspect is one of at least [an] a HDTV format type aspect ratio and a NTSC format type aspect ratio.

46. A photographic film printer according to claim 45, wherein the picture aspect information indicates one of at

least the HDTV format type aspect ratio or the NTSC format type aspect ratio.

47. A photographic film printer according to claim 46, wherein the print format changing means includes movable masks for the processed photographic film or for photographic print paper.

48. A photographic film printer according to claim 45, wherein the HDTV format type aspect ratio is 16:9.

49. A photographic film printer according to claim 45, wherein the NTSC format type aspect ratio is 3:4.

50. A photographic film printer according to claim 45, wherein the picture aspect information is magnetically recorded on the photographic film, and the detecting means magnetically detects the picture aspect information.

51. *A photographic film printer according to claim 45, wherein the photographic area aspect has a maximum aspect ratio corresponding to the HDTV format type aspect ratio.*

52. *A photographic film printer according to claim 45, wherein*

the picture aspect information is recorded in the marginal edge area between a first edge of the photographic film and an exposure area of the photographic film,

film information is recorded in the marginal edge area between the first edge of the photographic film and the exposure area of the photographic film, and

user input information is recorded in a second marginal edge area between a second edge of the photographic film and the exposure area of the photographic film, the second edge being opposite the first edge.

53. *A photographic camera comprising:*

a first housing for housing a photographic film cartridge containing a photographic film strip;

a second housing for housing a photographic film strip drawn from the cartridge;

film feed means for feeding the photographic film strip between the first and second housings;

exposure means for exposing an image onto an exposure area of the photographic film strip, the exposure area having a maximum size corresponding to a HDTV format size;

control means including a micro-computer electrically connected to a frame size selector switch operable by a user for controlling an aspect of a photographic print to be produced from the exposed photographic film strip; and

recording means responsive to a control signal output from the micro-computer for magnetically recording an aspect ratio signal in a first area between an edge of the photographic film strip and the exposure area of the photographic film strip, the aspect ratio signal corresponding to one of a plurality of aspect formats indicating the aspect of the image to be printed on photo-sensitive print paper, wherein

the first area has optically pre-recorded thereon film information about the film itself, and

the plurality of aspect formats includes a format in which the aspect has a ratio of 9:16 and a size of 16.9 mm×30 mm, the 30 mm extending across a width of the film strip.

54. *A photographic film printer comprising:*

film feeding means for feeding a processed photographic film in a first predetermined direction;

paper feeding means for feeding a photographic print paper in a second predetermined direction,

wherein the processed photographic film has a first marginal area between a first edge of the processed photographic film and an effective exposure area of the processed photographic film, the first marginal area having arranged thereon a film position detecting signal for controlling the film feeding means;

detecting means disposed along a path of the processed photographic film for detecting picture aspect information magnetically recorded in a second marginal area of the processed photographic film for controlling the paper feeding means;

film feed control means responsive to the film position detecting signal for stopping the processed photographic film at predetermined positions,

wherein the processed photographic film has film information used to print the photographic film recorded in a second marginal area between a second edge of the processed photographic film and the effective exposure area of the processed photographic film, and the second marginal area is located opposite the first marginal area; and

mask means used to print the image from the processed photographic film onto the photographic print paper, the mask means having a variable opening width controlled in response to the picture aspect information detected by the detecting means.

55. A photographic system comprising:

a photographic camera including
a first housing for housing a photographic film cartridge containing a photographic film strip, the photographic film strip having film positioning holes in a first marginal area thereof,

a second housing for housing a photographic film strip drawn from the cartridge,

film feed means for feeding the photographic film strip between the first and second housings,

control means including a micro-computer electrically connected to a selector switch operable by a user, and

recording means responsive to the micro-computer for magnetically recording information input by the user, the information including an aspect signal recorded in a second marginal area of the photographic film strip opposite the first marginal area and between an edge of the photographic film strip and the effective area of the photographic film strip, the aspect signal indicating the aspect of the effective area to be printed on photosensitive print paper, wherein the second marginal area has film information pre-recorded thereon; and

a photographic printer including
detecting means for magnetically detecting the aspect signal recorded in the second marginal area of a photographic film,

means for determining whether the aspect signal detected by the detecting means is correct, and

printing format changing means for automatically changing a photographic area aspect according to the aspect signal detected by the detecting means when the aspect signal is determined to be correct, wherein the photographic area aspect is one of at least a HDTV format type aspect ratio and a NTSC format type aspect ratio.

56. A photographic system comprising:

a photographic camera including
a first housing for housing a photographic film cartridge containing a photographic film strip, the photographic film strip having film positioning holes in a first marginal area thereof,

a second housing for housing a photographic film strip drawn from the cartridge,

film feed means for feeding the photographic film strip between the first and second housings,

control means including a micro-computer electrically connected to a selector switch operable by a user, and

recording means responsive to the micro-computer for magnetically recording information input by the user, the information including an aspect signal recorded in a second marginal area of the photographic film strip opposite the first marginal area and between an edge of the photographic film strip and the effective area of the photographic film strip, the aspect signal indicating the aspect of the effective area to be printed on photosensitive print paper, wherein the second marginal area has film information pre-recorded thereon; and

a photographic printer including

film feeding means for feeding a processed photographic film in a first predetermined direction; and

paper feeding means for feeding a photographic print paper in a second predetermined direction, wherein the processed photographic film has the film positioning holes located in the first marginal area for controlling the film feeding means, and the processed photographic film has the aspect signal recorded in the second marginal area for controlling the paper feeding means.

57. A photographic printing method comprising the steps of:

magnetically detecting picture aspect information recorded in a marginal edge area of a photographic film;

determining whether the magnetically detected picture aspect ratio information is correct; and

changing a photographic area aspect according to the magnetically detected picture aspect information when the picture aspect ratio information is determined to be correct.

* * * * *