



US00RE36781E

United States Patent [19]

[11] E

Patent Number: Re. 36,781

Lee et al.

[45] Reissued Date of Patent: Jul. 18, 2000

[54] DIFFERENTIAL COMPARATOR FOR AMPLIFYING SMALL SWING SIGNALS TO A FULL SWING OUTPUT

[75] Inventors: Thomas H. Lee, Cupertino; Kevin S. Donnelly, San Francisco, both of Calif.

[73] Assignee: Rambus, Inc., Mountain View, Calif.

[21] Appl. No.: 09/291,091

[22] Filed: Apr. 13, 1999

Related U.S. Patent Documents

Reissue of:

[64] Patent No.: 5,621,340
Issued: Apr. 15, 1997
Appl. No.: 08/510,141
Filed: Aug. 2, 1995

[51] Int. Cl. H03K 17/10; H03K 17/04; H03F 3/45

[52] U.S. Cl. 327/65; 327/77; 327/89; 327/374

[58] Field of Search 327/63, 65, 77, 327/89, 205, 333, 374, 375, 384, 307, 563

[56] References Cited

U.S. PATENT DOCUMENTS

3,863,080 1/1975 Steckler 327/9
4,110,641 8/1978 Payne 327/67
4,249,095 2/1981 Hsu 327/53
4,394,587 7/1983 McKenzie et al. 327/66

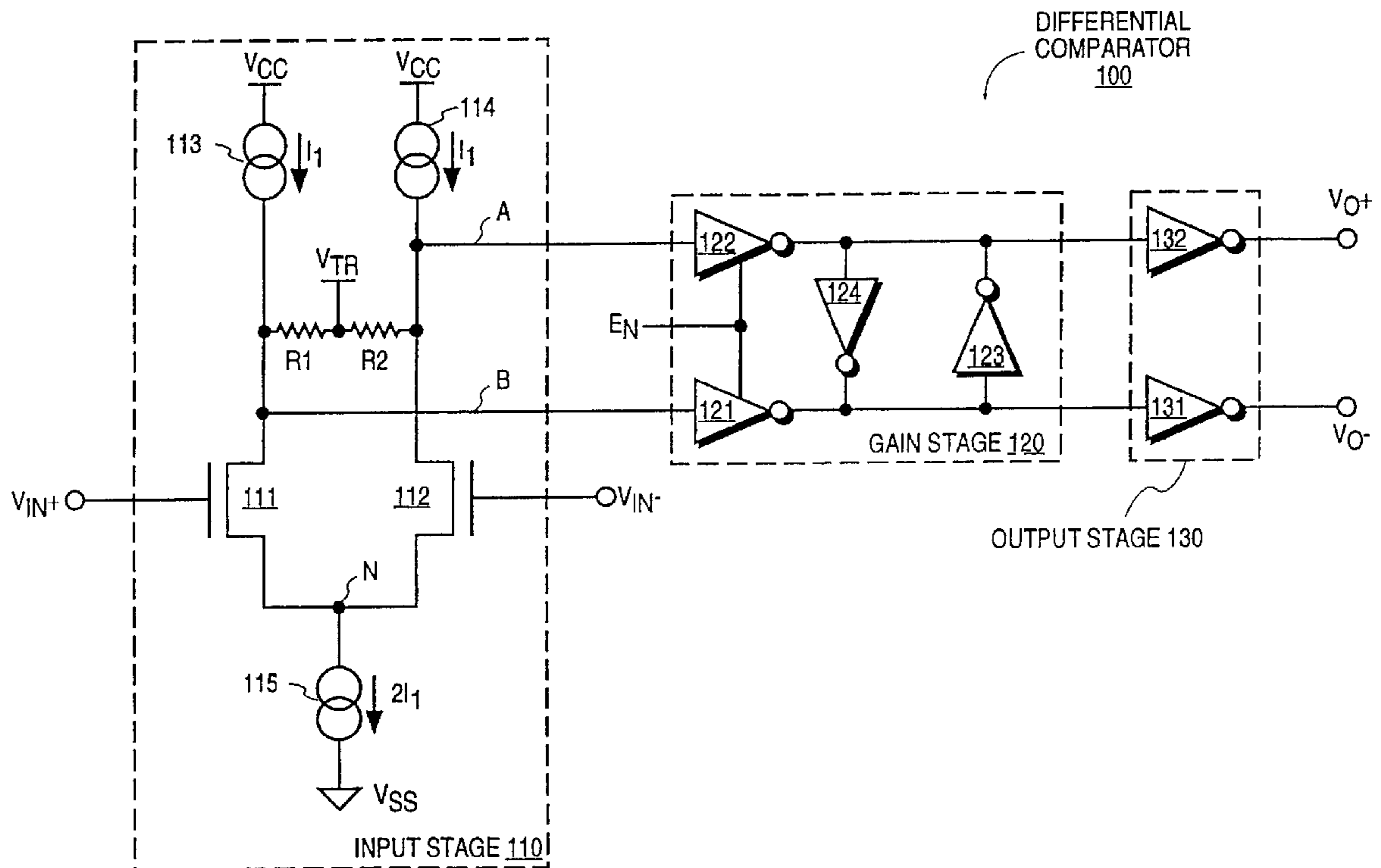
4,547,685 10/1985 Wong 327/54
4,573,022 2/1986 Koga 330/261
4,739,194 4/1988 Glasby et al. 330/261
5,057,788 10/1991 Ushida et al. 330/261
5,077,489 12/1991 Gola et al. 327/77
5,132,640 7/1992 Tanaka et al. 330/261
5,281,865 1/1994 Yamashita et al. 327/208
5,289,054 2/1994 Lucas 327/202
5,448,200 9/1995 Fernandez et al. 327/202
5,488,321 1/1996 Johnson 327/66

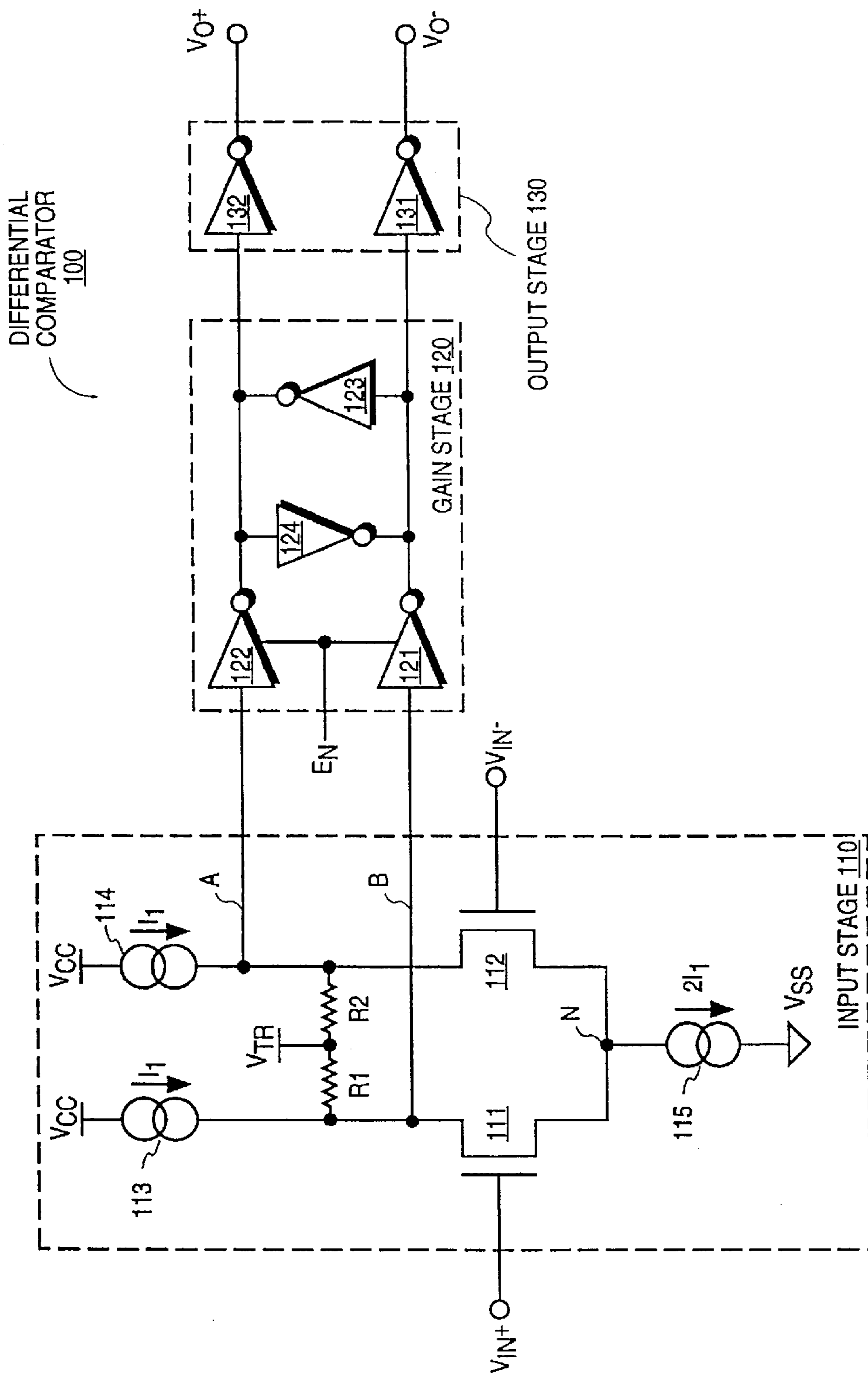
Primary Examiner—Timothy P. Callahan
Assistant Examiner—Terry L. Englund
Attorney, Agent, or Firm—Pennie & Edmonds LLP

[57] ABSTRACT

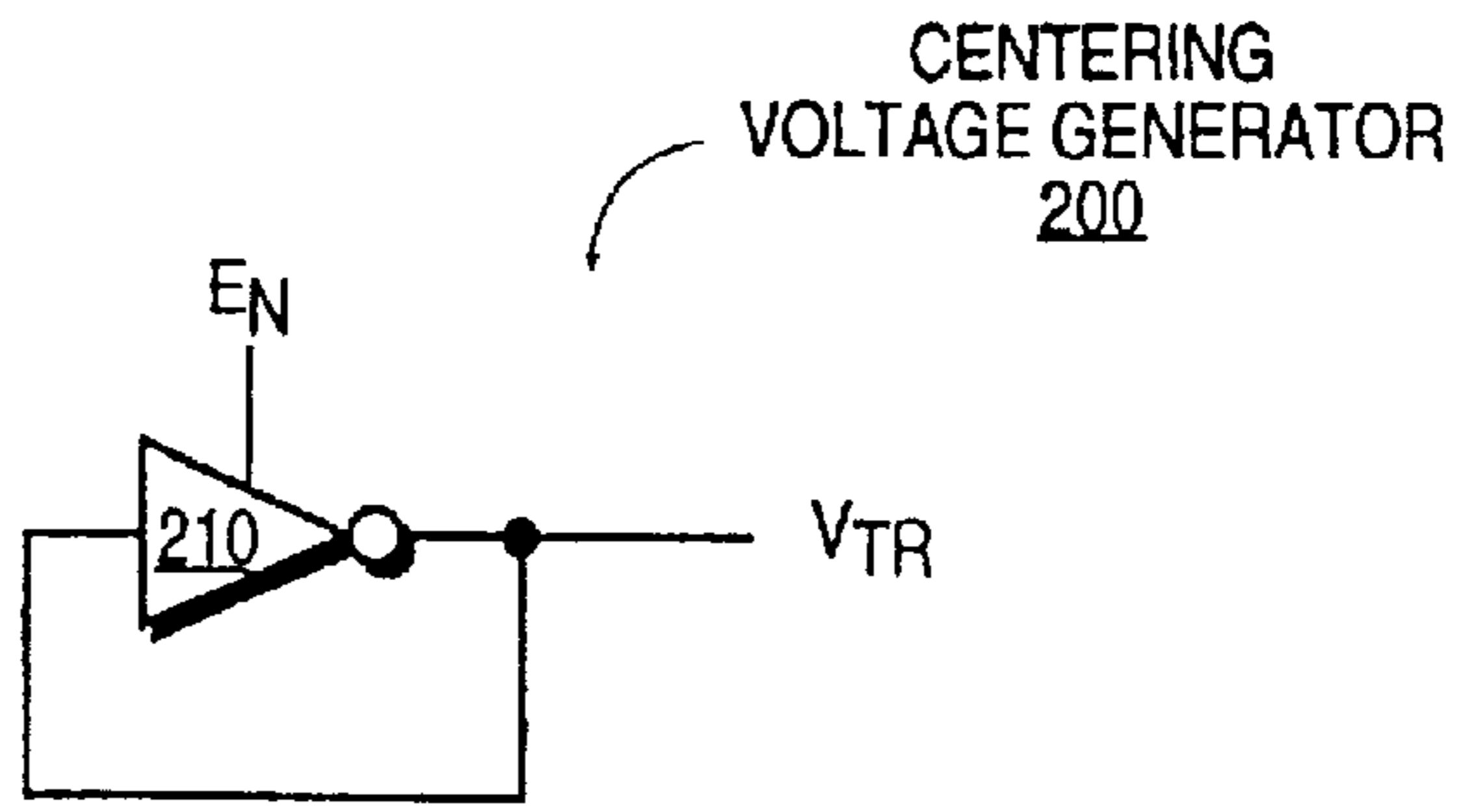
A differential comparator that amplifies small swing signals to full swing signals. The differential comparator comprises a current switch having a pair of inputs coupled to receive a pair of small swing complementary input signals and a pair of complementary outputs that output complementary signals. The complementary signals output by the current switch have a voltage swing that centers about a predetermined voltage in response to the complementary input signals. The differential comparator further comprises first and second inverters coupled to receive the output complementary signals, wherein each inverter has a trip point voltage [equal] corresponding to the predetermined voltage. The first and second inverters output full swing complementary output signals in response to the complementary signals output by the current switch.

20 Claims, 3 Drawing Sheets

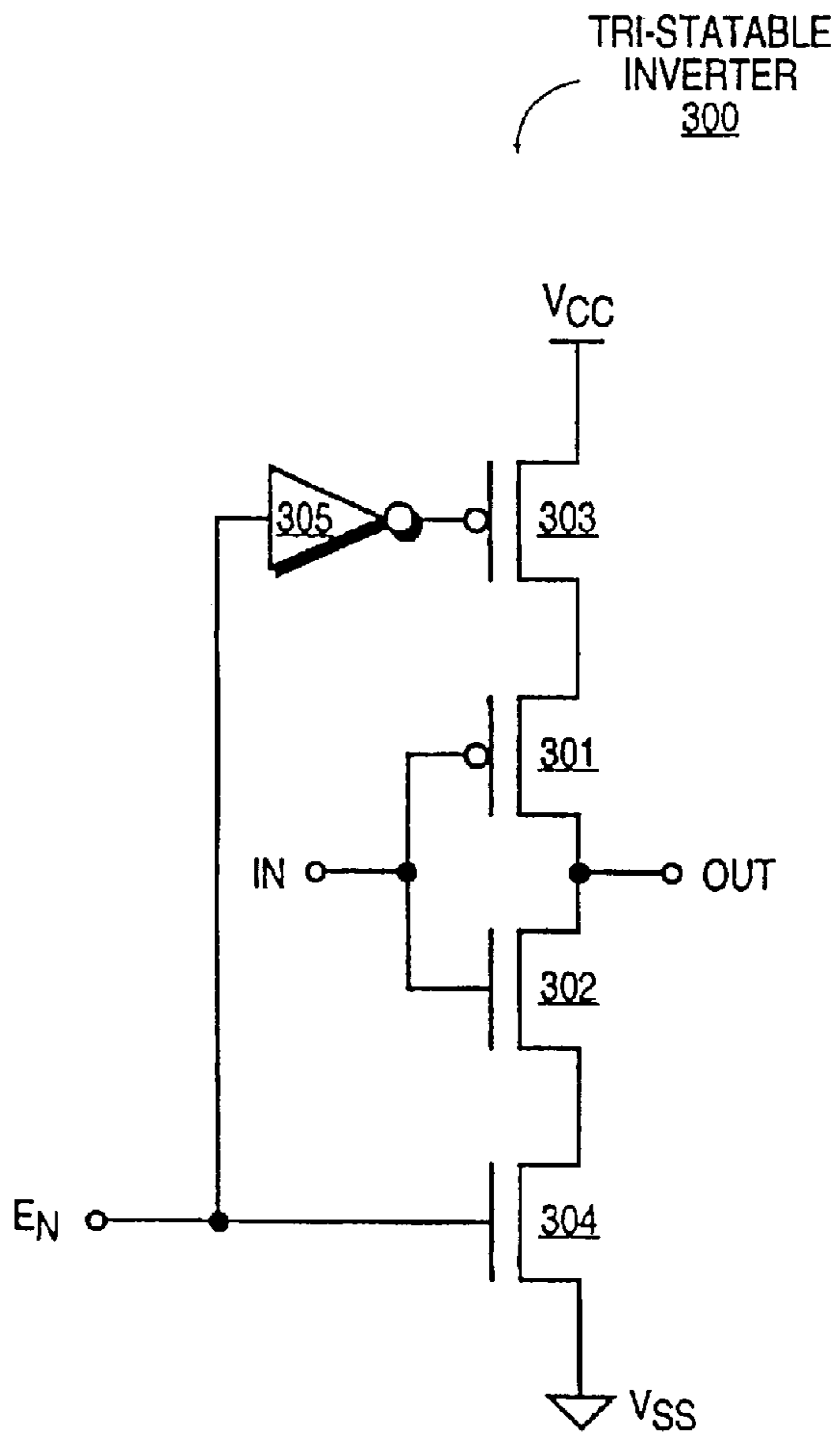




**FIG. 1**



**FIG. 2**



**FIG. 3**



## DIFFERENTIAL COMPARATOR FOR AMPLIFYING SMALL SWING SIGNALS TO A FULL SWING OUTPUT

Matter enclosed in heavy brackets [ ] appears in the original patent but forms no part of this reissue specification; matter printed in italics indicates the additions made by reissue.

### FIELD OF THE INVENTION

The present invention relates generally to comparator circuits and more particularly to differential comparator circuits that amplify small swing input signals to full swing output signals.

### BACKGROUND OF THE INVENTION

A differential comparator is often used in clock acquisition circuits such as delay-locked loops (DLL) and phase locked loops (PLL) to compare the value of a voltage at a first terminal of the differential comparator to the value of a voltage at a second terminal of the differential comparator. For some applications, the signals provided at the inputs of the differential comparator are "small swing" signals that have small amplitudes relative to the supply voltage levels. For example, for CMOS circuits wherein the supply voltage VCC is equal 3.3 volts and system ground VSS is equal to zero volts, a small swing signal may have an amplitude of 0.5 volts that swings between a low of 1.5 volts and a high of 2.0 volts. A "full swing" signal swings approximately between 3.3 volts and zero volts (ground).

Clock acquisition circuits are typically used to clock the circuitry of an integrated circuit, and the differential comparator must output full swing signals to drive the integrated circuit. The differential comparator circuit must therefore provide gain to amplify the small swing input signals to a full swing output signal. For higher frequency applications, it is difficult to provide the necessary gain using prior differential comparators.

### SUMMARY AND OBJECTS OF THE INVENTION

Therefore, it is an object of the present invention to provide a differential comparator that amplifies small swing signals into full swing signals.

It is a further object of the present invention to provide a CMOS differential comparator that amplifies small swing input signals to full swing output signals at higher frequencies.

A differential comparator that amplifies small swing signals to full swing signals is described. The differential comparator comprises a current switch having a pair of inputs coupled to receive a pair of small swing complementary input signals and a pair of complementary outputs that output complementary signals. The complementary signals output by the current switch have a voltage swing that centers about a predetermined voltage in response to the complementary input signals. The differential comparator further comprises first and second inverters coupled to receive the complementary signals, wherein each inverter has a trip point voltage [equal] *corresponding* to the predetermined voltage. The first and second inverters output full swing complementary output signals in response to the complementary signals.

Because the outputs of the current switch center about the trip point voltage of the inverters, the inverters provide a

current path between VCC and VSS during normal operation. According to one embodiment, the differential comparator includes circuitry for disabling the differential comparator during a power-down mode of operation such that the differential comparator draws little or no current. Part of this functionality is provided by designing the inverters to be tri-statable. The need for additional disabling circuitry for disabling the current switch, is dictated by the circuit topology of the current switch.

Other objects, features, and advantages of the present invention will be apparent from the accompanying drawings and from the detailed description which follows below.

### BRIEF DESCRIPTION OF THE DRAWINGS

The present invention is illustrated by way of example and not by way of limitation in the figures of the accompanying drawings, in which like references indicate similar elements, and in which:

FIG. 1 shows a differential comparator according to one embodiment.

FIG. 2 shows a voltage generator that supplies a trip point voltage  $V_{TR}$ .

FIG. 3 shows a tri-statable inverter according to one embodiment.

FIG. 4 shows a differential comparator as including a bias circuit.

### DETAILED DESCRIPTION

A differential comparator according to the present embodiments quickly amplifies small swing differential input signals to generate full swing complementary output signals. The differential comparator generally comprises an input stage, a gain stage, and an output stage. The gain stage generally comprises inverters each having a trip point voltage of  $V_{TR}$ . The input stage acts as a current switch that outputs complementary output signals each having a voltage swing that centers about the trip point voltage  $V_{TR}$ . Centering the output signals of the input stage about the trip point voltage  $V_{TR}$  enables the inverters of the gain stage to switch on and off quickly to provide full swing output signals. The output stage provides additional gain.

FIG. 1 shows a differential comparator **100** according to one embodiment. Differential comparator **100** comprises an input stage **110**, a gain stage **120**, and an output stage **130** coupled in series. Input stage **110** accepts small swing differential input signals  $V_{in+}$  and  $V_{in-}$ . The amplitude of the differential input signal  $V_{in}$  may be, for example, 0.5 volts. Input stage **110** provides a modest gain, and output signals of input stage **110** are provided via output nodes A and B to gain stage **120**, which amplifies the output signals of the input stage **110** into full swing signals. Output stage **130** provides further gain, speeding the transitions between the rail voltages and providing sufficient output current to drive the capacitive load of the remaining portions of the integrated circuit.

Input stage **110** is shown as a common source differential amplifier that operates as a current switch wherein a current having a value of  $2I_1$  is switched between the transistors of the differential amplifier. Alternative current switch and differential amplifier architectures may be used. Input stage **110** includes a differential pair of NMOS transistors **111** and **112**, each having their sources coupled to system ground VSS via a common node N and current source **115** and their drains coupled to the supply rail VCC via current sources **113** and **114**, respectively. Current sources **113** and **114** are

each selected to source a current having a value of  $I_1$ , and current source **115** is selected to sink a current having a value of twice  $I_1$ . Output node A is taken at the drain of transistor **112**, and output node B is taken at the drain of node **111**.

Resistors **R1** and **R2** having equal values are coupled in series between output nodes A and B. A trip point supply voltage  $V_{TR}$  is provided at the common node between resistors **R1** and **R2**. The trip point supply voltage  $V_{TR}$  causes the output voltages at output nodes A and B to center around the trip point supply voltage  $V_{TR}$ . The output voltage at each output node of the input stage **110** is approximately  $(V_{TR} \pm I_1 R)$ , wherein  $R$  is the value of each of the transistors **R1** and **R2**. Wherein  $V_{in+} > V_{in-}$ , the voltage at output node A is approximately  $(V_{TR} + I_1 R)$ , and the voltage at output node B is approximately  $(V_{TR} - I_1 R)$ . Conversely, wherein  $V_{in+} < V_{in-}$ , the voltage at output node A is approximately  $(V_{TR} - I_1 R)$ , and the voltage at output node B is approximately  $(V_{TR} + I_1 R)$ .

Gain stage **120** comprises a first input inverter **121** having its input coupled to output node B and a second input inverter **122** having its input coupled to output node A. Both input inverters are CMOS inverters. The value of trip point supply voltage  $V_{TR}$  is selected to be the value of the trip point voltage of input inverters **121** and **122** such that inverters **121** and **122** switch on and off quickly.

Because the output voltages of input stage **110** center about the trip point voltage of input inverters **121** and **122**, input inverters **121** and **122** can change states quickly. Unfortunately, the MOS transistors of inverters **121** and **122** are never fully switched off. To reduce the power consumption of input inverters **121** and **122**, input inverters **121** and **122** are tri-statable. Each input inverter therefore includes an enable input coupled to receive an enable signal **EN** for coupling and decoupling the inverters from the supply rails. The enable signal may be deasserted low, for example, when the integrated circuit and differential comparator are to be placed in a power-down mode wherein power consumption of differential comparator **100** is reduced. As will be described with respect to FIG. 4, differential comparator **100** draws no current when operating in the power-down mode.

Cross-coupled inverters **123** and **124** are provided to improve the power supply rejection of differential comparator **100**. Disturbances in the power supplies of input inverters **121** and **122** may result in one of the output signals of the input inverters beginning to switch between rail voltages before the other output signal. Cross-coupled inverters **123** and **124** compensate for this effect. Inverter **123** has its input coupled to the output of input inverter **121** and its output coupled to the output of input inverter **122**. Similarly, inverter **124** has its input coupled to the output of inverter **122** and its output coupled to the output of inverter **121**. The cross-coupled inverters help to ensure that the differential output voltages of gain stage **120** cross approximately at the threshold voltage  $V_{TR}$ .

Cross-coupled inverters **123** and **124** need not provide as much current as input inverters **121** and **122**. Therefore, according to one embodiment, the channel widths of the CMOS transistors of cross-coupled inverters **123** and **124** are approximately 20% of the channel widths for input inverters **121** and **122**. Cross-coupled inverters **123** and **124** may also be tri-statable.

Output stage **130** comprises inverters **131** and **132**. The input of inverter **131** is coupled to the output of inverter **121**, and the input of inverter **132** is coupled to the output of inverter **122**. Output inverters **131** and **132** provide addi-

tional gain and provide sufficient current to drive the capacitive load of an integrated circuit coupled to the outputs of differential comparator **100**. Output inverters **131** and **132** may also be tri-statable.

FIG. 2 shows a voltage generator **200** that supplies the trip point voltage  $V_{TR}$ . According to the present embodiment, centering voltage generator **200** comprises an inverter **210** having the same operating characteristics as input inverters **121** and **122** wherein inverter **210** has its output coupled to its input. The use of matching inverter **210** makes the centering voltage generator **200** less susceptible to process variations that affect the trip point voltages of input inverters **121** and **122**.

FIG. 3 shows a tri-statable inverter **300** according to one embodiment. Tri-statable inverter **300** generally comprises a CMOS inverter which includes a PMOS transistor **301** and an NMOS transistor **302** having their gates commonly coupled to an input node and their drains commonly coupled to an output node. The source of PMOS transistor **301** is coupled to VCC via PMOS transistor **303**, and the source of NMOS transistor **302** is coupled to system ground VSS via NMOS transistor **304**. The enable signal **EN** is coupled directly to the gate of transistor **304** and to the gate of transistor **303** via inverter **305** for removing the conductive path between VCC and VSS when it is desirable to reduce the power consumption of differential comparator **100**. When the enable signal **EN** is logic low (deasserted), transistors **303** and **304** are switched off. Tri-statable inverter **300** operates as a normal CMOS inverter when enable signal **EN** is logic high (asserted). Enable signal **EN** may alternatively be provided as an active low signal.

FIG. 4 shows differential comparator **100** as further including a bias circuit **400** for ensuring proper current values of current sources **113**, **114** and **115** and for switching off the current sources when differential comparator **100** is placed in the power-down mode. According to one embodiment, current sources **113** and **114** are matched PMOS transistors, and current source **115** is an NMOS transistor. Bias circuit **400** provides biasing current to the gates of transistors **113**, **114** and **115** such that transistors **113**–**115** conduct the appropriate amount of source-drain current.

Bias circuit **400** generally comprises a pair of differential input transistors **411** and **412** that are approximately half the size of transistors **111** and **112** of input stage **110**. The gates of transistors **411** and **412** are coupled to differential input voltages  $V_{in+}$  and  $V_{in-}$ , respectively. The sources of transistors **411** and **412** are commonly coupled to VSS via NMOS transistor **415**, which is approximately half the size of NMOS transistor **115** of input stage **110**. NMOS transistor **416** has matching characteristics to transistor **415** and is coupled to receive an external bias current  $I_1$  from a current source **417**, which may be a bandgap voltage generator. Transistor **416** is coupled in a current mirroring arrangement to the gate of transistor **415** such that transistor **415** sinks a current  $I_1$ . The gate of transistor **115**, which is twice the size of transistor **416**, also has its gate coupled to the gate of transistor **416** such that transistor **115** sinks a current  $2I_1$ .

The drains of transistors **411** and **412** are commonly coupled to the drain of transistor **413**. Transistor **413** has its gate commonly coupled to the gates of transistors **113** and **114** in a current mirroring arrangement such that the drain currents of transistor **113** and **114** are of the desired value.

Transistor **420** and inverter **421** are provided such that the current sources of input stage **110** are switched off to disable differential comparator **100** during power-down mode. Tran-

## 5

sistor 420 has its drain coupled to the gate of transistor 115, its source coupled to VSS, and its gate coupled to the output of inverter 421. Inverter 421 has its input coupled to receive enable signal EN. When the EN signal is deasserted low, the output of inverter 421 is high such that transistor 420 is switched on and the gate of transistor 115 is pulled towards ground. This results in all of the current sources 113, 114, and 115 of input stage 110 being switched off. Deasserting the EN signal also tri-states input inverters 121 and 122. Cross-coupled inverters 123 and 124 ensure that the inputs to inverters 131 and 132 are biased to a logic state. Thus, differential comparator 100 draws no current while operating in the power-down mode.

In the foregoing specification the invention has been described with reference to specific exemplary embodiments thereof. It will, however, be evident that various modifications and changes may be made thereto without departing from the broader spirit and scope of the invention. The specification and drawings are, accordingly, to be regarded in an illustrative rather than restrictive sense.

What is claimed is:

1. A differential comparator comprising:

a current switch having a pair of inputs coupled to receive a pair of small swing complementary input signals and a pair of complementary outputs that output first complementary output signals having a voltage swing centered about a predetermined voltage in response to the complementary input signals; and

first and second inverters coupled to receive the first complementary output signals, wherein each inverter has a trip point voltage [equal] *corresponding* to the predetermined voltage, the first and second inverters outputting second complementary output signals in response to the first complementary output signals, wherein the second complementary output signals are full swing complementary output signals.

2. The differential comparator of claim 1, wherein the current switch comprises:

first and second matched input transistors coupled as a common source differential amplifier, wherein gates of the input transistors form the inputs of the current switch and drains of the input transistors form the outputs of the current switch;

first and second current sources coupled between the respective drains of the input transistors and an operating supply voltage;

a third current source coupled between sources of the input transistors and system ground; and

first and second resistors coupled in series between the drains of the input transistors, wherein a common node between the first and second resistors is maintained at *approximately* the trip point voltage of the first and second inverters.

3. The differential comparator of claim 2, wherein an enable signal is provided to the differential comparator such that the differential comparator is enabled for normal operation when the enable signal is asserted, the differential comparator further comprising circuitry for disabling the differential comparator in response to the enable signal being deasserted during a power-down mode of operation wherein the differential comparator draws no power.

4. The differential comparator of claim 2, further comprising cross-coupled third and fourth inverters, wherein an input of the third inverter is coupled to an output of the first inverter and an output of the third inverter is coupled to an output of the second inverter, and an input of the fourth

## 6

inverter is coupled to the output of the second inverter and an output of the fourth inverter is coupled to the output of the first inverter.

5. The differential comparator of claim 4, further comprising fifth and sixth inverters having inputs coupled to the outputs of the first and second inverters, respectively, wherein the fifth and sixth inverters provide additional gain.

6. A differential comparator comprising:

a differential amplifier comprising a pair of inputs coupled to receive a pair of small swing complementary input signals, a pair of outputs that output first complementary output signals, and first and second resistors coupled in series between the pair of outputs, wherein a common node between the first and second resistors is maintained at a predetermined voltage such that an output swing of the differential amplifier is centered about the predetermined voltage; and

first and second inverters coupled to receive the first complementary output signals, wherein each inverter has a trip point voltage [equal] *corresponding* to the predetermined voltage, the first and second inverters outputting second complementary output signals in response to the first complementary output signals, wherein the second complementary output signals are full swing complementary output signals.

7. The differential comparator of claim 6, wherein an enable signal is provided to the differential comparator such that the differential comparator is enabled for normal operation when the enable signal is asserted, the differential comparator further comprising circuitry for disabling the differential comparator in response to the enable signal being deasserted during a power-down mode of operation wherein the differential comparator draws no power.

8. The differential comparator of claim 6, further comprising cross-coupled third and fourth inverters, wherein an input of the third inverter is coupled to an output of the first inverter and an output of the third inverter is coupled to an output of the second inverter, and an input of the fourth inverter is coupled to the output of the second inverter and an output of the fourth inverter is coupled to the output of the first inverter.

9. The differential comparator of claim 8, further comprising fifth and sixth inverters having inputs coupled to the outputs of the first and second inverters, respectively, wherein the fifth and sixth inverters provide additional gain.

10. A differential comparator comprising:

a differential amplifier comprising a pair of inputs coupled to receive a pair of small swing complementary input signals, a pair of outputs that output first complementary output signals and first and second resistors coupled in series between the pair of outputs, wherein a common node between the first and second resistors is maintained at a predetermined voltage such that an output swing of the differential amplifier is centered about the predetermined voltage;

first and second inverters coupled to receive the first complementary output signals, wherein each inverter has a trip point voltage [equal] *corresponding* to the predetermined voltage, the first and second inverters outputting second complementary output signals in response to the first complementary output signals, wherein the second complementary output signals are full swing complementary output signals;

cross-coupled third and fourth inverters, wherein an input of the third inverter is coupled to an output of the first inverter and an output of the third inverter is coupled to

an output of the second inverter, and an input of the fourth inverter is coupled to the output of the second inverter and an output of the fourth inverter is coupled to the output of the first inverter; and

fifth and sixth inverters having inputs coupled to the outputs of the first and second inverters, respectively, wherein the fifth and sixth inverters [provided] provide additional gain.

11. The differential comparator of claim 10, further comprising a seventh inverter having matching characteristics to the first and second inverters, wherein an output of the seventh inverter is coupled to an input of the seventh inverter and the common node between the first and second resistors.

12. A differential comparator comprising:

a current switch having a pair of inputs coupled to receive a pair of small swing complementary input signals and a pair of outputs that output first complementary output signals having a voltage swing centered about a predetermined voltage in response to the complementary input signals; and

first and second inverters coupled to receive the first complementary output signals, wherein each inverter has a trip point voltage [equal] corresponding to the predetermined voltage, the first and second inverters outputting second complementary output signals in response to the first complementary output signals, wherein the second complementary output signals are full swing complementary output signals;

cross-coupled third and fourth inverters, wherein an input of the third inverter is coupled to an output of the first inverter and an output of the third inverter is coupled to an output of the second inverter, and an input of the fourth inverter is coupled to the output of the second inverter and an output of the fourth inverter is coupled to the output of the first inverter; and

fifth and sixth inverters having inputs coupled to the outputs of the first and second inverters, respectively, wherein the fifth and sixth inverters provide additional gain.

13. The differential comparator of claim 12, further comprising first and second resistors coupled in series between the pair of outputs of the current switch, wherein a common node between the first and second resistors is maintained at the predetermined voltage.

14. The differential comparator of claim 13, further comprising a seventh inverter having matching characteristics to the first and second inverters, wherein an output of the seventh inverter is coupled to an input of the seventh inverter and the common node between the first and second resistors.

15. A method for generating full swing complementary signals from small swing complementary signals comprising the steps of:

generating complementary output signals having a voltage swing centered about a predetermined voltage in response to the small swing complementary signals;

providing the complementary output signals to a pair of inverters each having a trip voltage [equal] corresponding to the predetermined voltage; and

outputting from the pair of inverters the full swing complementary signals.

16. The differential comparator of claim 1, further comprising cross-coupled third and fourth inverters, wherein an input of the third inverter is coupled to an output of the first inverter and an output of the third inverter is coupled to an output of the second inverter, and an input of the fourth inverter is coupled to the output of the second inverter and an output of the fourth inverter is coupled to the output of the first inverter.

17. A differential comparator comprising:

a differential amplifier comprising a pair of inputs coupled to receive a pair of small swing complementary input signals and a pair of complementary outputs that output first complementary output signals having a voltage swing centered about a predetermined voltage in response to the complementary input signals; and

first and second inverters coupled to receive the first complementary output signals, wherein each inverter has a trip point voltage corresponding to the predetermined voltage, the first and second inverters outputting second complementary output signals in response to the first complementary output signals, wherein the second complementary output signals are full swing complementary output signals.

18. The differential comparator of claim 17, wherein the differential amplifier includes first and second resistors coupled in series between the pair of outputs, and a common node between the first and second resistors is maintained at the predetermined voltage.

19. The differential comparator of claim 18, wherein the differential amplifier further includes:

first and second matched input transistors coupled as a common source differential amplifier, wherein gates of the input transistors form the inputs of the differential amplifier and drains of the input transistors form the outputs of the differential amplifier;

first and second current sources coupled between the respective drains of the input transistors and an operating supply voltage; and

a third current source coupled between sources of the input transistors and system ground.

20. The differential comparator of claim 18, further comprising cross-coupled third and fourth inverters, wherein an input of the third inverter is coupled to an output of the first inverter and an output of the third inverter is coupled to an output of the second inverter, and an input of the fourth inverter is coupled to the output of the second inverter and an output of the fourth inverter is coupled to the output of the first inverter.

\* \* \* \* \*