



US00RE36623E

United States Patent [19]

[11] E

Patent Number: **Re. 36,623**

Wang et al.

[45] **Reissued Date of Patent: *Mar. 21, 2000**

[54] **PROCESS FOR PECVD OF SILICON OXIDE USING TEOS DECOMPOSITION**

[56]

References Cited

[75] Inventors: **David Nin-Kou Wang**, Saratoga; **John M. White**, Hayward; **Kam S. Law**, Union City; **Cissy Leung**, Fremont; **Salvador P. Umotoy**, Antioch; **Kenneth S. Collins**, San Jose, all of Calif.; **John A. Adamik**, Byfield, Mass.; **Ilya Perlov**, Santa Clara; **Dan Maydan**, Los Altos Hills, both of Calif.

U.S. PATENT DOCUMENTS

3,934,060	1/1976	Burt et al. .
4,717,596	1/1988	Barbee et al. .
4,872,947	10/1989	Wang et al. .
4,892,753	1/1990	Wang et al. .
5,000,113	3/1991	Wang et al. .

[73] Assignee: **Applied Materials, Inc.**, Santa Clara, Calif.

FOREIGN PATENT DOCUMENTS

0204182	12/1986	Germany .
46-22490	6/1971	Japan .
47-23173	4/1972	Japan .
47-24272	6/1972	Japan .
53-131300	7/1978	Japan C01B 33/12
59-4028	1/1984	Japan H01L 21/302
62-214177	6/1987	Japan C23C 16/44

[*] Notice: This patent issued on a continued prosecution application filed under 37 CFR 1.53(d), and is subject to the twenty year patent term provisions of 35 U.S.C. 154(a)(2).

OTHER PUBLICATIONS

This patent is subject to a terminal disclaimer.

Wang, D.N.K. et al., ULSI Science and Technology, p. 712 (1987) (No Month Avail.).

IBM Technical Disclosure Bulletin, vol. 28, No. 9 (Feb. 1986).

Adams, A.C., Proceedings of the Symposium on Reduced Temperature Processing for VLSI (eds.. Reif and Srinivasas), p. 111 (1986) (No Month Avail.).

Kukushkin, N.V. et al., Sov. Phys. Tech. Phys., vol. 30(10), p. 1227 (1985) (No Month Avail.).

Jiang Ruolian et al., Chinese Journal of Semiconductors, vol. 6, No. 4, p. 429 (1985) (No Month Avail.).

Pande, K.P. and Davies, P.W., J. Electronic Materials, vol. 13, No. 3, p. 593 (1984) (No Month Avail.).

Woodward, J. et al., Thin Solid Films, vol. 85, p. 61 (1981) (No Month Avail.).

Cameron, D.C. et al., M. Schulz and G. Pensl (eds.) Insulating Films on Semiconductors, Springer, Berlin, p. 281 (1981) (No Month Avail.).

Priestly, I.B. and Call, P.J., Thin Solid Films, vol. 69, p. 39 (1980) (No Month Avail.).

Grant, A.J. et al., Inst. Phys. Conf. Ser. No. 50: Chapter 4, p. 266 (1979) (No Month Avail.).

Rand, M.J., J. vac. Sci. Technol., pp. 420-427 (Mar./Apr. 1979).

Kirov, K.I. et al., Phys. Stat. Sol. (a), vol. 48, p. 609 (1978) (No Month Avail.).

[21] Appl. No.: **08/752,972**

[22] Filed: **Dec. 2, 1996**

Related U.S. Patent Documents

Reissue of:

[64] Patent No.: **4,892,753**
Issued: **Jan. 9, 1990**
Appl. No.: **07/262,993**
Filed: **Oct. 26, 1988**

U.S. Applications:

[63] Continuation of application No. 08/407,482, Mar. 16, 1995, abandoned, which is a continuation of application No. 07/819,296, Jan. 8, 1992, abandoned, which is a division of application No. 06/944,492, Dec. 19, 1986, Pat. No. 5,000, 113.

[51] **Int. Cl.⁷** **H05H 1/24**

[52] **U.S. Cl.** **427/579; 427/294; 427/314**

[58] **Field of Search** **427/579, 294, 427/314**

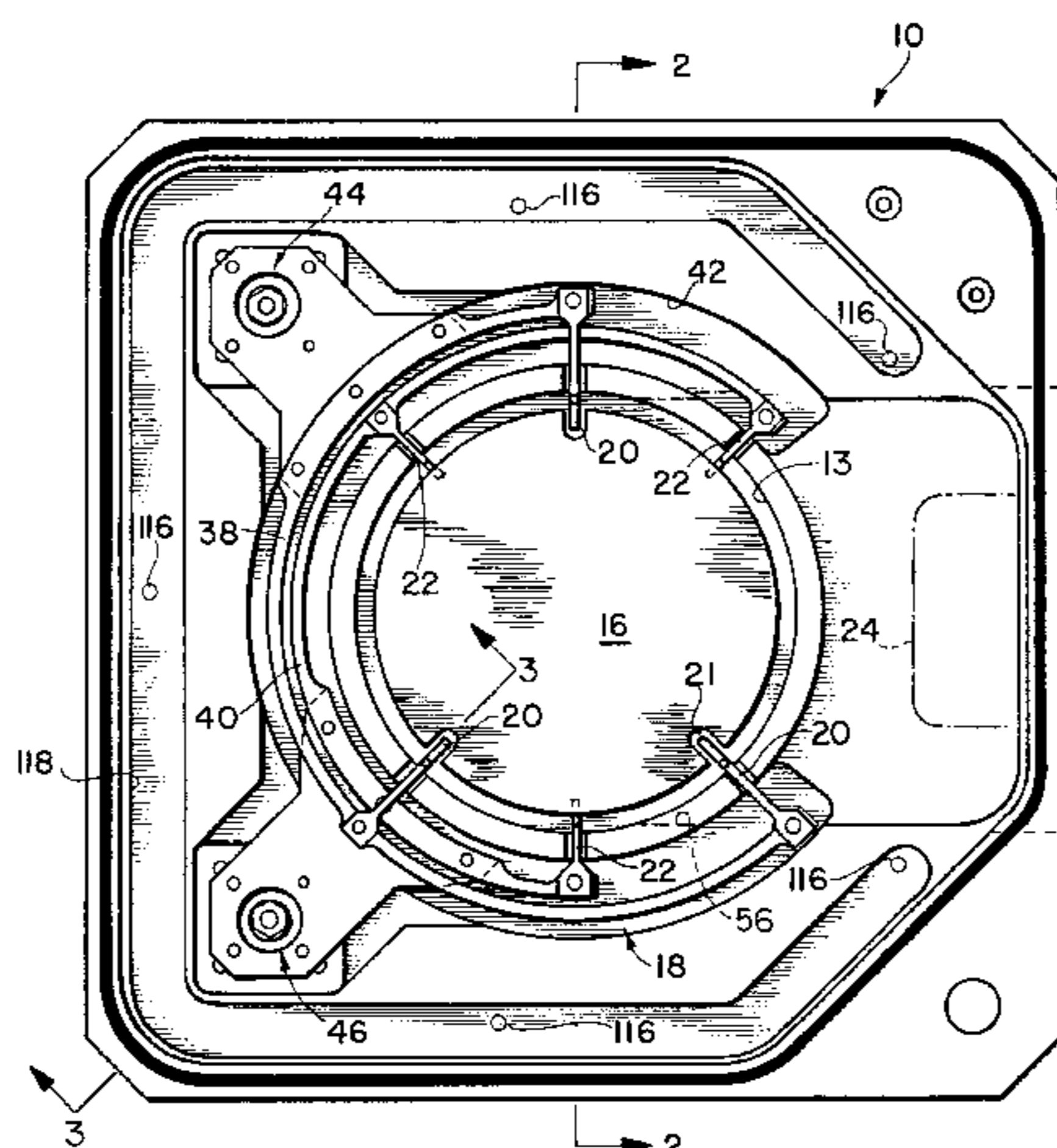

- Amick, J.A. et al., *J. Vac. Sci. Technol.*, vol. 14, No. 5, p. 1053 (1977) (No Month Avail.).
- Mukherjee, S.P. et al., *Thin Solid Films*, vol. 14, p. 105 (1972) (No Month Avail.).
- Feltnish, I. et al., *Izv. Akad. Navk. LatvSSR Ser. fiz. tekhn. Navk. No. 2*, p. 48 (1970) (No Month Avail.).
- Secrist, D.R. et al., *Solid-State Electronics*, vol. 9, p. 180 (1966) (No Month Avail.).
- Secrist, D.R. et al., *J. Electrochem. Soc.*, vol. 113, p. 914 (1966) (No Month Avail.).
- Ing, S.W. and Davern, W., *J. Electrochem. Soc.*, vol. 112:3, p. 284 (1965) (No Month Avail.).
- Ing, S.W. and Davern, W., *J. Electrochem. Soc.*, vol. 111:1, p. 120 (1964) (No Month Avail.).
- Levy, R.A. et al., *J. Electrochem. Soc.*, vol. 134, No. 1, p. 430 (1987) (No Month Avail.).
- Tseitlin, G.M. et al., *Nuclear Instruments in Methods for Physics Research*, vol. 19–20, p. 931 (1987) (No Month Avail.).
- Becker, F.S. et al., *J. Vac. Sci. Technol. B4(3)*, p. 732 (May/June 1986).
- Becker, F.S. et al., *Proceedings of the Symposium on Reduced Temperature Processing for VLSI* (eds. Reif and Srinivasas), p. 148 (1986) (No Month Avail.).
- Binder, H. et al., *Ex. Abs. of the 18th (1986 International) Conference on Solid State Devices and Materials*, p. 299 (1986) (No Month Avail.).
- IBM Technical Disclosure Bulletin*, vol. 27, No. 12, p. 7252 (May 1985).
- Yamada, K. et al., *IEDM tech. Dig.*, p. 702 (1985) (No Month Avail.).
- Becker, F.S. et al., *ECS Ext. Abstr.*, vol. 85–2, p. 380 (1985) (No Month Avail.).
- Minkina, V.G., *USSR J. Appl. Chem.*, vol. 58, No. 5, p. 1053 (1985) (No Month Avail.).
- Smolisky, G. et al., *J. Electrochem. Soc.*, vol. 132, No. 4, p. 950 (Apr. 1985).
- Tsunoda, Y., *Japanese J. Appl. Phys.*, vol. 24, No. 3, p. 365 (1985) (No Month Avail.).
- Vogel et al., *J. Electron. Mat.*, vol. 14, No. 3, p. 329 (1985) (No Month Avail.).
- Mori, S. et al., *IEEE CAT. No. 85 CH 2125(3)*, p. 16 (1985) (No Month Avail.).
- Jonsson, U. et al., *Thin Solid Films*, vol. 124, p. 117 (1985) (No Month Avail.).
- Murarka, S.P., *J. Appl. Phys.*, vol. 56, No. 8, p. 2225 (1984) (No Month Avail.).
- Vogel, R.H. et al., *Technical Report U.S. Army Research Office Contract DAAG29–81–K–0007* (1984) (No Month Avail.).
- IBM Technical Disclosure Bulletin*, vol. 26, No. 4, pp. 1980–1982 (Sep. 1983).
- Levin, R.M. and Evans-Lutterodt, K., *J. vac. Sci. Technol. B1(1)*, p. 54 (Jan.–Mar. 1983).
- Adams, A.C., *VLSI Technology*, p. 93 (McGraw-Hill, New York 1983) (No Month Avail.).
- Levin, R.M. and Adams, A.C., *J. Electrochem. Soc.*, vol. 129, No. 7, p. 1588 (1982) (No Month Avail.).
- Li, P.C. and Tsang, P.J., *J. Electrochem. Soc.*, vol. 129, No. 1, p. 165 (1982) (No Month Avail.).
- Song, S.H. et al., *J. Electrochem. Soc.*, vol. 129, No. 4, p. 841 (1982) (No Month Avail.).
- Levin, R.M., *J. Electrochem. Soc.*, vol. 129, No. 8, p. 1765 (1982) (No Month Avail.).
- Vogel, R.H. et al., *ECS Ext. Abstr.*, vol. 82–2, p. 305 (1982) (No Month Avail.).
- Adams, A.C. and Capiro, C.D., *J. Electrochem. Soc.*, vol. 126, No. 6, p. 1042 (1979) (No Month Avail.).
- Balagurov et al., *Sov. J. Opt. Technol.* 46(2), p. 100 (Feb. 1979).
- Huppertz et al., *IEEE Transactions on Electron Devices*, vol. ED–26, No. 4, p. 658 (1979) (No Month Avail.).
- Tsunoda, Y., *Japanese J. Appl. Phys.*, vol. 17, No. 12, p. 2085 (1978) (No Month Avail.).
- Maeda, K. and Sato, J., *Denki Kagaku*, vol. 45, No. 10, p. 654 (1977) (No Month Avail.).
- Pliskin, W.A., *J. vac. Sci. Technol.*, vol. 14, No. 5, p. 1064 (Sep./Oct. 1977).
- Tsunoda, Y., *Japanese J. Appl. Phys.*, vol. 16, No. 10, p. 1869 (1977) (No Month Avail.).
- Gorokhov, E.B. et al., *Izvestiya Akademii Nauk SSSR, Neorganicheskie Materialy*, vol. 12, No. 2, p. 270 (1976) (No Month Avail.).
- Sugawara, K. et al., *Chemical Vapor Deposition*, ed. Blocher, J.M., No Date Avail.
- Hinterman, H.E. and Hall, L.H., *Electrochem. Soc.*, Princeton, NJ (1975), No Month Avail.
- Hoffmann, G. et al., *J. Phys. D. Appl. Phys.*, vol. 8, p. 1044 (1975), No Month Avail.
- Wohlheiter, V.D. et al., *ECS Ext. Abstr.*, vol. 75–1, p. 424 (1975), No Month Avail.
- Arai et al., *Japan J. Appl. Phys. Suppl. 2, Pt. 1*, p. 757 (1974), No Month Avail.
- Tsunoda, Y., *Japanese J. Appl. Phys.*, vol. 13, No. 11, p. 1901 (1974), No Month Avail.
- Parekh, P.C. et al., *Solid-State Electronics*, vol. 14, p. 281 (1971), No Month Avail.
- Arai, E. et al., *Japanese J. Appl. Phys.*, vol. 9, No. 6, p. 691 (1970), No Month Avail.
- Kalnynya, R.P. et al., *Izv. Akad. Nauk Latv SSR Ser. fiz. tekhn. Nauk. No. 2*, 121 (1969) (No Month Avail.).
- Aboaf, J.A., *J. Electrochem. Soc.*, vol. 116, p. 1732 (1969) (No Month Avail.).
- Heunisch, G.W., *Anal. Chim. Acta.*, vol. 48, No. 2, p. 405 (1969) (No Month Avail.).
- Oroshnik, J. et al., *J. Electrochem. Soc.*, vol. 115, No. 6, p. 649 (1968) (No Month Avail.).
- Nakai, Y., *ECS Ext. Abstr.*, vol. 5, No. 1, p. 215 (1968).
- Lee, D.B., *Solid-State Electronics*, vol. 10, p. 623 (1967), No Month Avail.
- Pliskin, W.A. and Lehman, H.S., *J. Electrochem. Soc.*, p. 1013 (Oct. 1965).
- Jordan, E.L., *J. Electrochem. Soc.*, vol. 108, No. 5, p. 478 (1961) (No Month Avail.).
- Klerer, J., *J. Electrochem. Soc.*, vol. 108, No. 11, p. 1070 (1961) (No Month Avail.).
- Pande, K.P. et al., *J. Appl. Phys.*, vol. 54(9), p. 5436 (1983) (No Month Avail.).
- Weiss, A.D., *Semiconductor International*, p. 88 (Jul. 1983). *Applied Materials CVD marketing report* (Jan. 1983).
- Burggraaf, P.S., *Semiconductor International*, pp. 23–24 (Mar. 1980).
- Mazerolles, P. et al., *Silicon, Germanium, Tin and Lead Compounds*, p. 155 (ed. Gielen 1986) (No Month Avail.).
- Nguyen, V.S. et al., *J. Electrochem. Soc.*, vol. 132, No. 8, p. 1925 (1985) (No Month Avail.).
- Nguyen, V.S. et al., *Proceedings of the Fifth Symposium on Plasma Processing*, p. 298 (ed. Mathad, Schwartz and Smolinsky 1985) (No Month Avail.).

- Nguyen, V.S. et al., ECS Ext. Abstr., vol. 84-2, p. 535 (1984) (No Month Avail.).
- Sinha, A.K., Solid State Technology, p. 133 (Apr. 1980).
- Vandenberg, M. and Hassan, M.S., Electrochem. Soc. Ext. Abstr., vol. 79(1), p. 234 (1979) (No Month Avail.).
- Virtmanis, A. et al., Izv. Akad. Navk. LatvSSR Ser. fiz. tekhn. Nauk. No. 1, p. 32 (1977) (No Month Avail.).
- Sinha, A.K., Electrochem. Soc. Ext. Abstract No. 242, p. 625 (1976) (No Month Avail.).
- Sterling, H.F. et al., Solid-State Electronics, vol. 8, p. 653 (1965) (No Month Avail.).
- Alt, L.L. et al., J. Electrochem. Soc., vol. 110, p. 465 (1963) (No Month Avail.).
- EPC Search Report for European counterpart application for Serial No. 944,492 (parent application for pending continuation application) (No Date Avail.).
- Krongelb, S., Electrochemical Technology, p. 251 (Jul.-Aug. 1968).
- Mackens, U. and Merkt, U., Thin Solid Films, vol. 97, pp. 53-61 (1982) (No Month Avail.).
- Eisele, K.M., J. Vac. Sci. Technol. B4(5), p. 1227 (Sep./Oct. 1986).
- Oehrlein, G.S., J. Electrochem. Soc.: Solid-State Science and Technology, p. 1002 (May 1986).
- Chemical Abstracts, vol. 101, No. 20, p. 292 (1984) (No Month Avail.).
- Fujino, T. et al., Oyo Buturi, vol. 53, No. 11, p. 957 (1984) (No Month Avail.).
- IBM Technical Disclosure Bulletin, vol. 25, No. 12, p. 6417 (May 1983).
- IBM Technical Disclosure Bulletin, vol. 25, No. 8, pp. 4405-4406 (Jan. 1983).
- Gerault, J.P. et al., Thin Solid Films, vol. 101, p. 83 (1983), No Month Avail.
- Gerault, J.P. et al., Ann. chim. Fr., vol. 8, p. 163 (1983) (No Month Avail.).
- Constant, G. et al., Solid State Chemistry, p. 267 (1982) (No Month Avail.).
- Gerault, J.P., J. Anal. Appl. Pyrolysis, vol. 4, p. 59 (1982), No Month Avail.
- Gerault, J.P. et al., Proc. of the Eighth Int'l Conf. on Chemical Vapor Deposition, Electrochem. Soc., p. 338 (1981) (No Month Avail.).
- IBM Technical Disclosure Bulletin, vol. 23, No. 5, p. 1879 (Oct. 1980).
- IBM Technical Disclosure Bulletin, vol. 22, No. 3, p. 1194 (1979) (No Month Avail.).
- Tanikawa, E. et al., Chemical Vapor Deposition (Wakefield and Blocher eds.), p. 2661 (1973) (No Month Avail.).
- Tanikawa et al., Denki Kagaku, vol. 41, No. 7, p. 491 (1971) (No Month Avail.).
- Kalnina, R. et al., Academy of Sciences of the Latvian SSR, News, Physical & Technical Science Series No. 13, p. 13 (1968) (No Month Avail.).
- Krongelb, S. et al., ECS Ext. Abstr., vol. 3, p. 108 (1966), No Month Avail.
- Connell, R.A. et al., J. Electrochem. Soc., vol. 112, p. 1198 (1965), No Month Avail.
- Scott, J. et al., RCA Rev. 26, p. 357 (1965) (No Month Avail.).
- Klerer, J., J. Electrochem. Soc., vol. 112, No. 5, p. 503 (1965) (No Month Avail.).
- "Selective Tungsten Deposition in a Varian 5101 Cold Wall CVD Reactor" (No Date Avail.).
- Shanfield and Bay, "Process Characterization of PSG and BPSG Plasma Deposition", Journal of Electrochemical Society, vol. 131, No. 9, (Sep. 1984).
- Pan et al, "The Composition and Properties of PECVD Silicon Oxide Films", J. Electrochem. Soc. vol. 132, No. 8, Aug. 1985, pp. 2012-2019.
- Hess, "Plasma-enhanced CVD: Oxides, nitrides, transition metals, and transition metal silicides", J. Vac. Sci. Technol. A2(2) Apr.-Jun. 1984, pp. 244-252.
- IONICS, No. 69, Jul. 1981. (English translation attached).
- Secrist et al, "Deposition of Silica Films by the Glow Discharge Technique", Journal of the Electrochemical Society, vol. 113, No. 9, Sep. 1986, pp. 914-920.

Primary Examiner—Bernard Pianalto
Attorney, Agent, or Firm—Irwin Ostroff

[57]

ABSTRACT

A high pressure, high throughput, single wafer, semiconductor processing reactor is disclosed which is capable of thermal CVD, plasma-enhanced CVD, plasma-assisted etchback, plasma self-cleaning, and deposition topography modification by sputtering, either separately or as part of in-situ multiple step processing. The reactor includes cooperating arrays of interdigitated susceptor and wafer support fingers which collectively remove the wafer from a robot transfer blade and position the wafer with variable, controlled, close parallel spacing between the wafer and the chamber gas inlet manifold, then return the wafer to the blade. A combined RF/gas feed-through device protects against process gas leaks and applies RF energy to the gas inlet manifold without internal breakdown or deposition of the gas. The gas inlet manifold is adapted for providing uniform gas flow over the wafer. Temperature-controlled internal and external manifold surfaces suppress condensation, premature reactions and decomposition and deposition on the external surface. The reactor also incorporates a uniform radial pumping gas system which enables uniform reactant gas flow across the wafer and directs purge gas flow downwardly and upwardly toward the periphery of the wafer for sweeping exhaust gases radially away from the wafer to prevent deposition outside the wafer and keep the chamber clean. The reactor provides uniform processing over a wide range of pressures including very high pressures. A low temperature CVD process for forming a highly conformal layer of silicon dioxide is also disclosed. The process uses very high chamber pressure and low temperature, and TEOS and ozone reactants. The low temperature CVD silicon dioxide deposition step is particularly useful for planarizing underlying stepped dielectric layers, either alone or in conjunction with a subsequent isotropic etch. A preferred in-situ multiple-step process for forming a planarized silicon dioxide layer uses (1) high rate silicon dioxide deposition at a low temperature and high pressure followed by (2) the deposition of the conformal silicon dioxide layer also at high pressure and low temperature, followed by (3) a high rate isotropic etch, preferably at low temperature and high pressure in the same reactor used for the two oxide deposition steps. Various combinations of the steps are disclosed for different applications, as is a preferred reactor self-cleaning step.

36 Claims, 6 Drawing Sheets

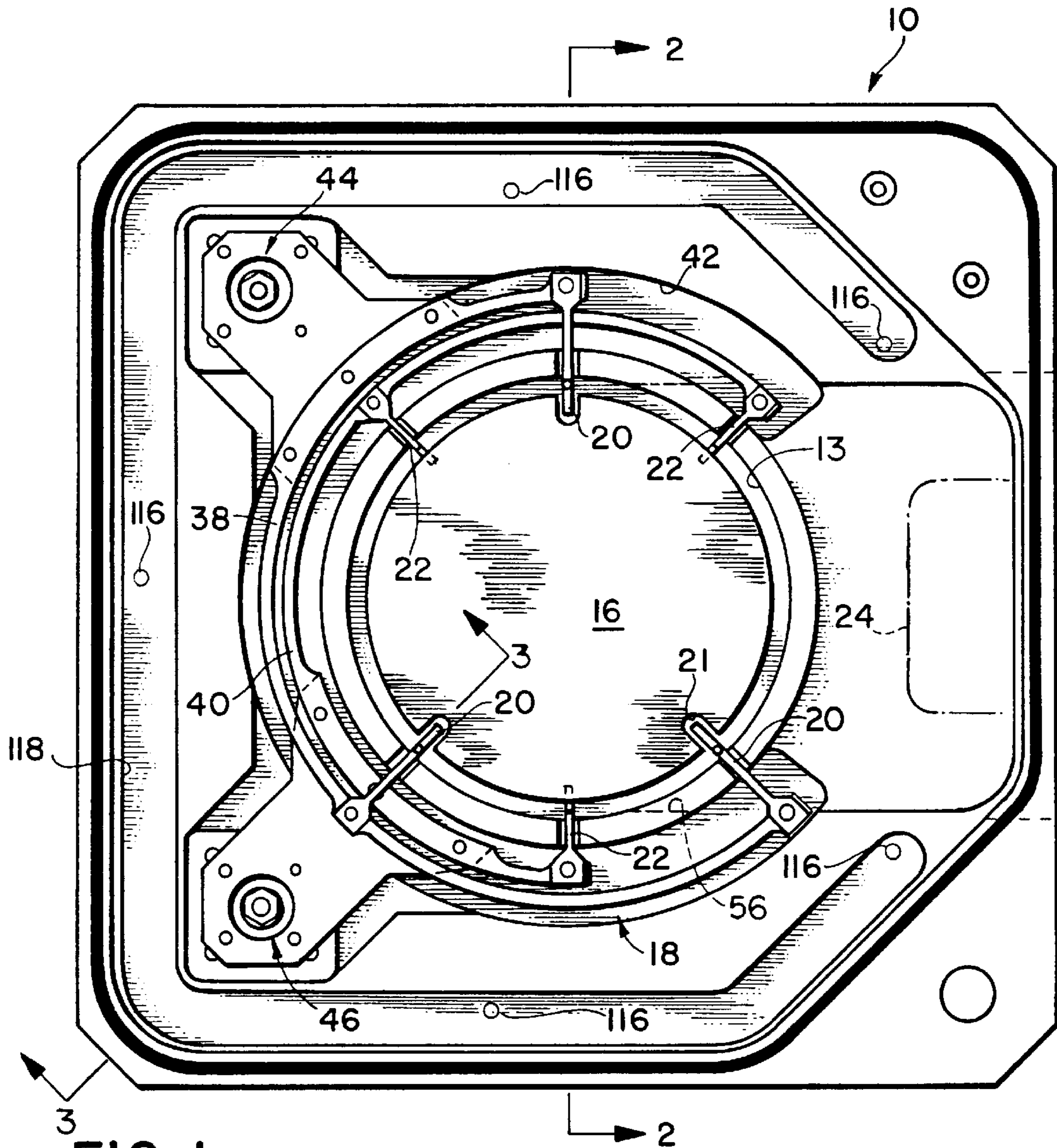

FIG. 1

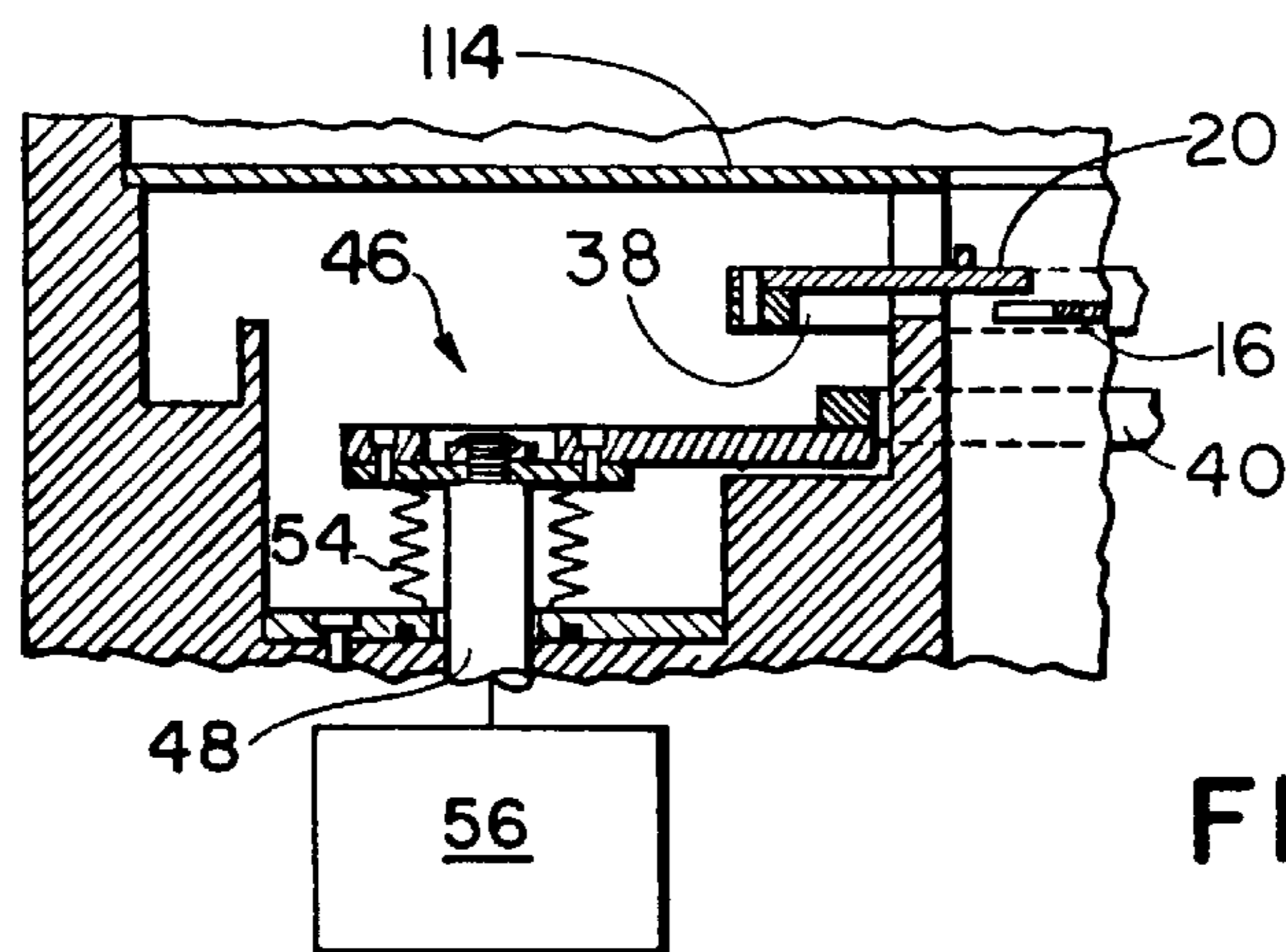

FIG. 3

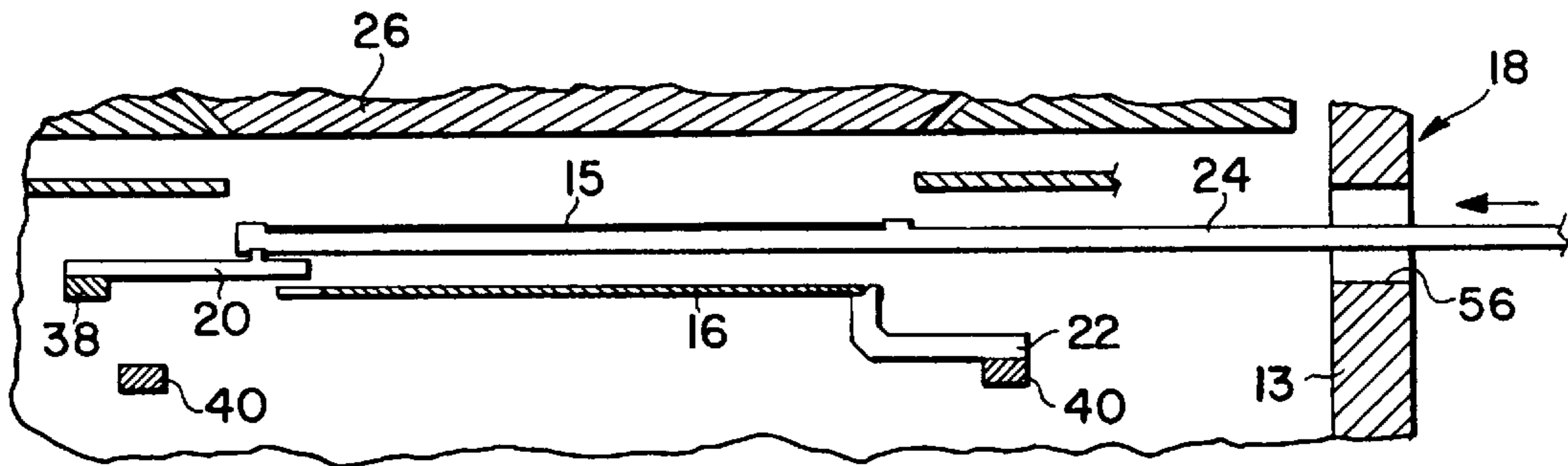

FIG. 4

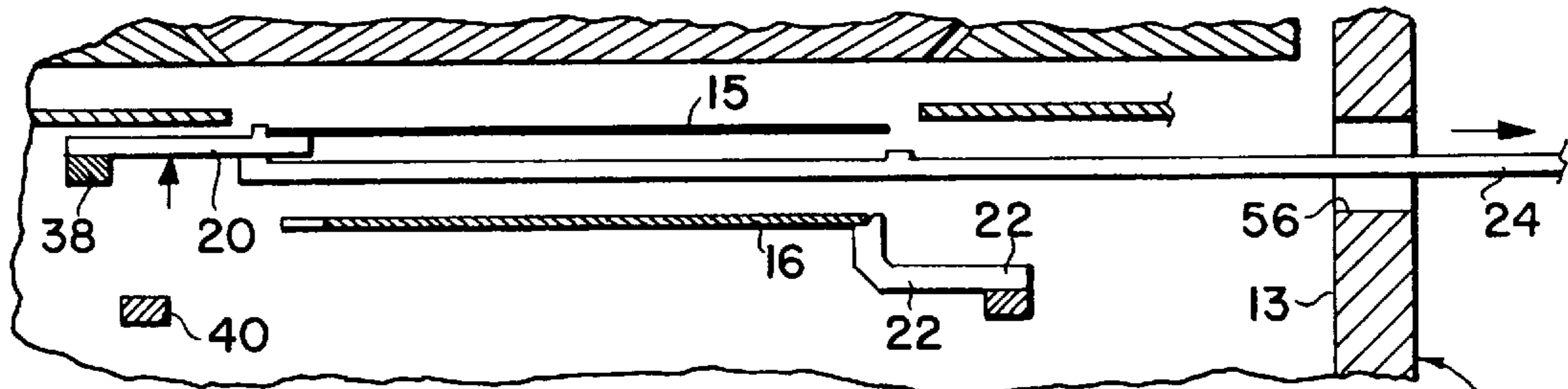

FIG. 5

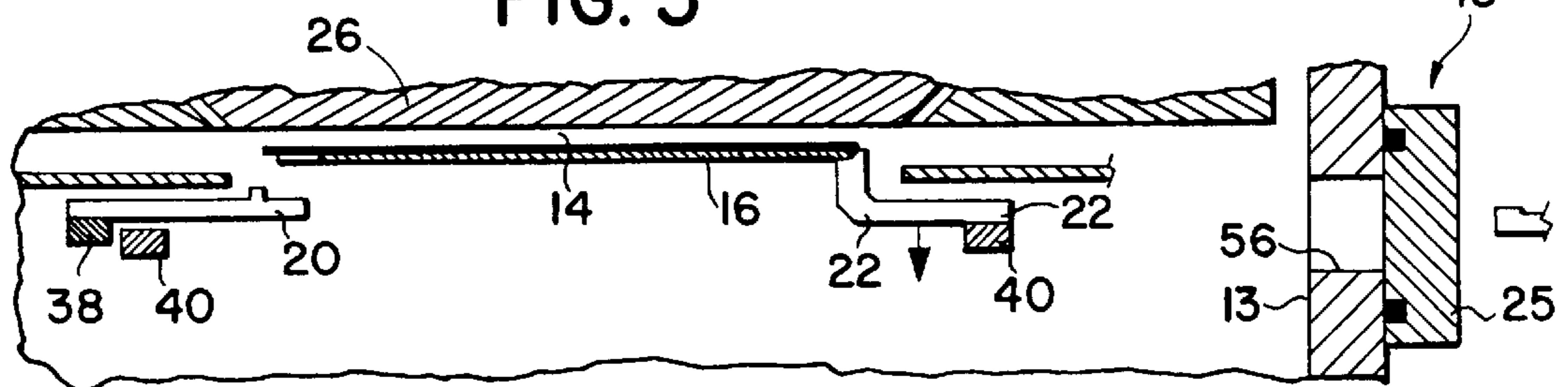

FIG. 6

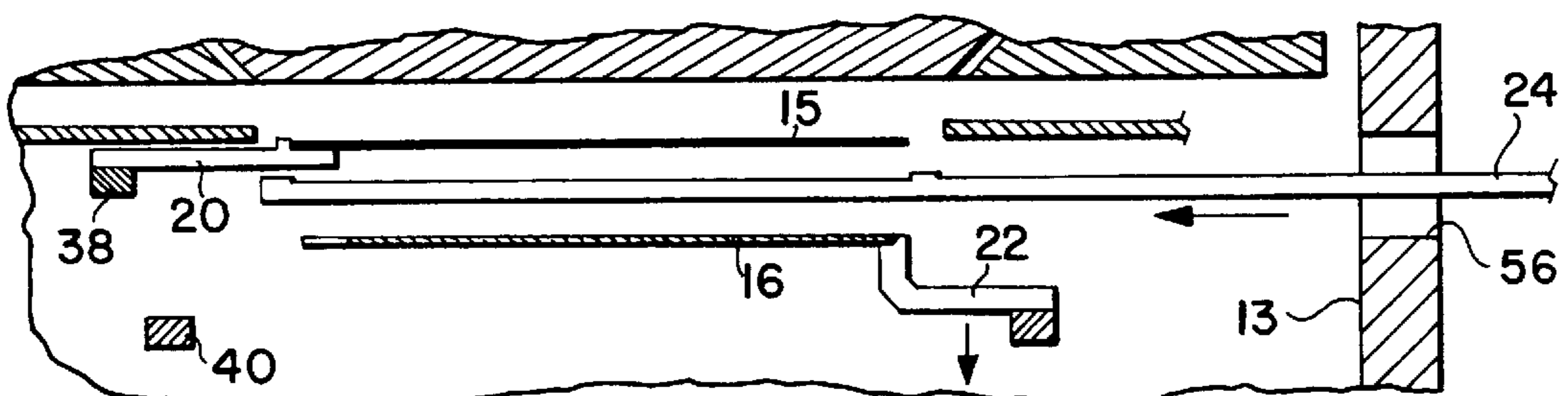

FIG. 7

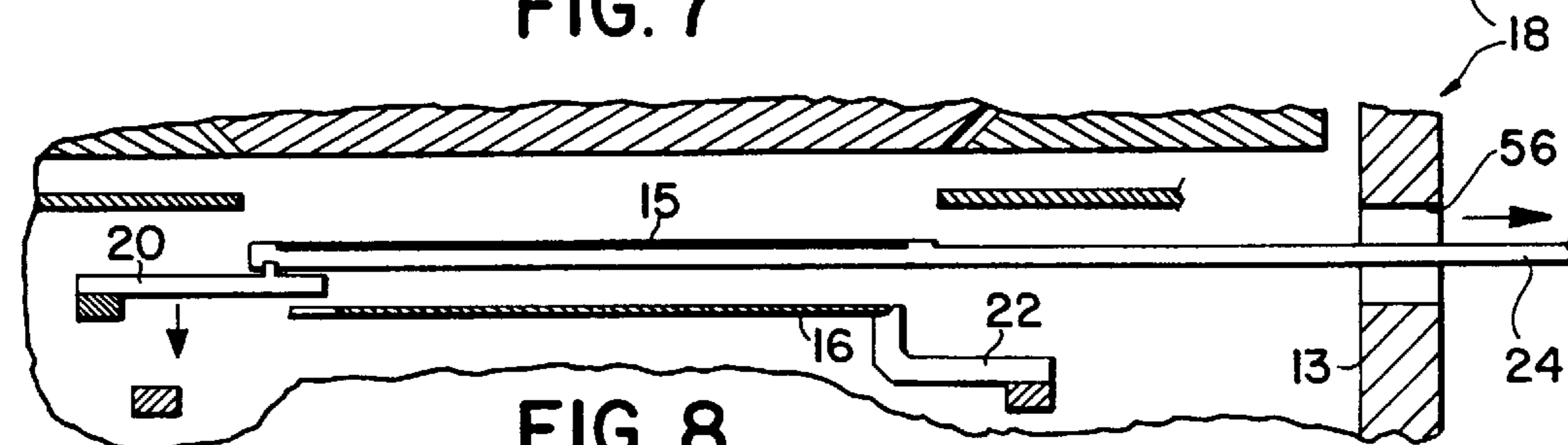
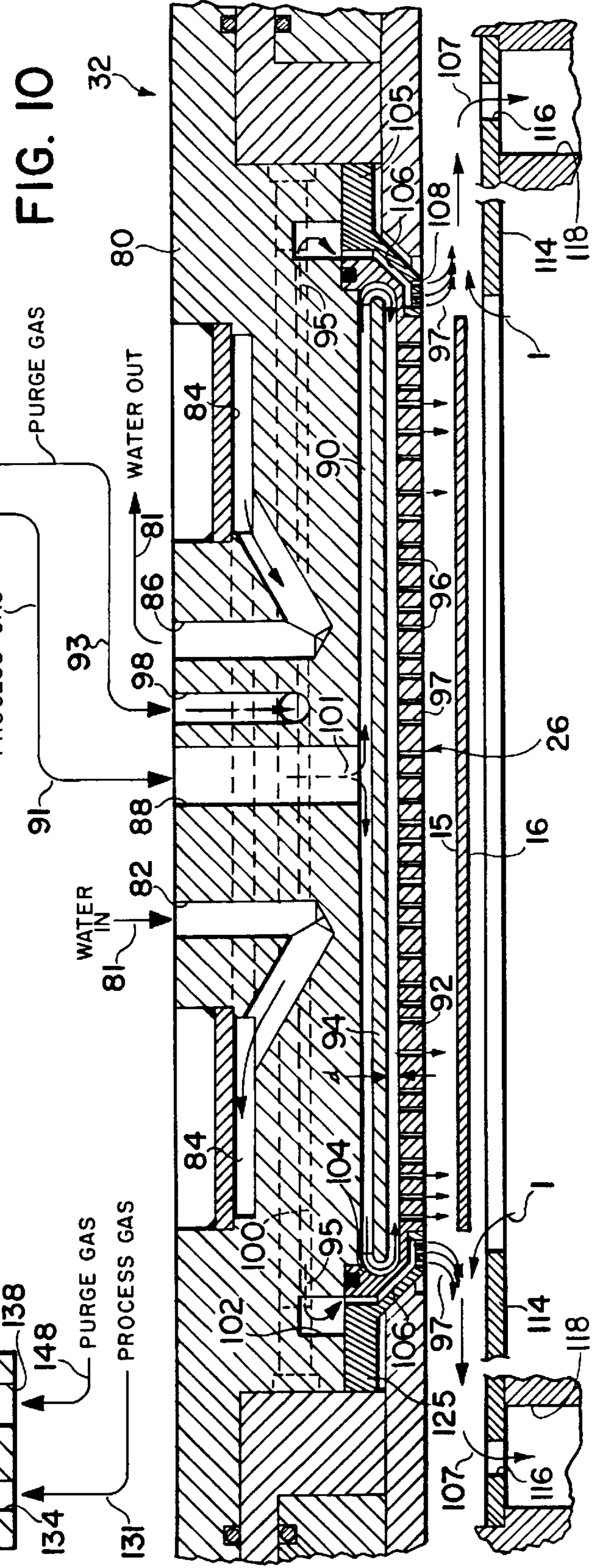
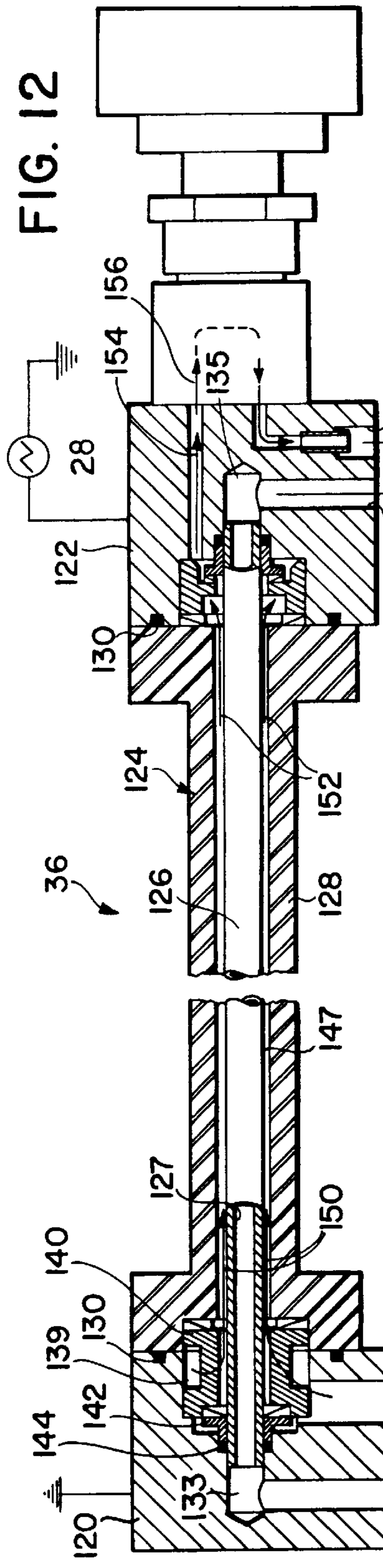

FIG. 8



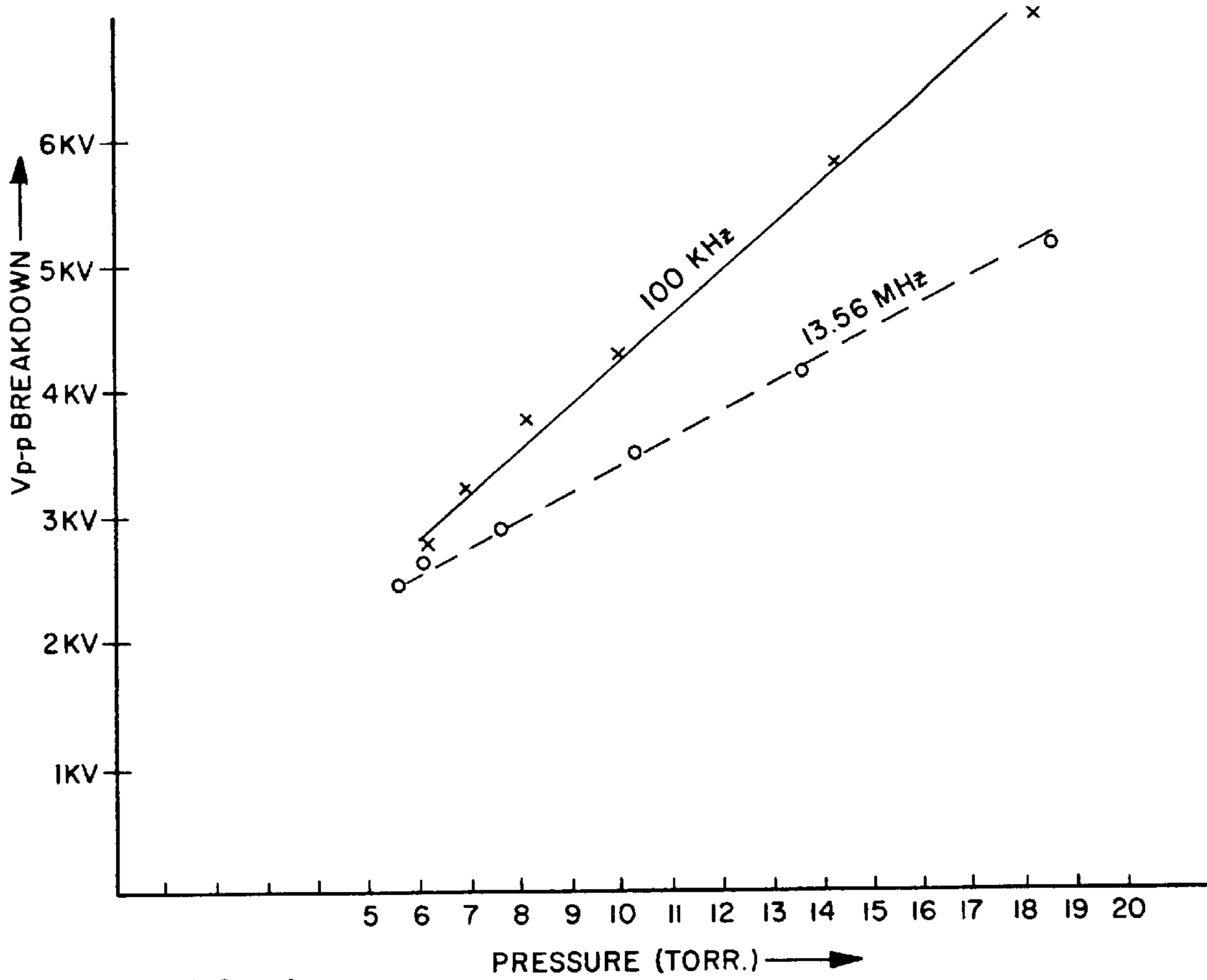

FIG. 14

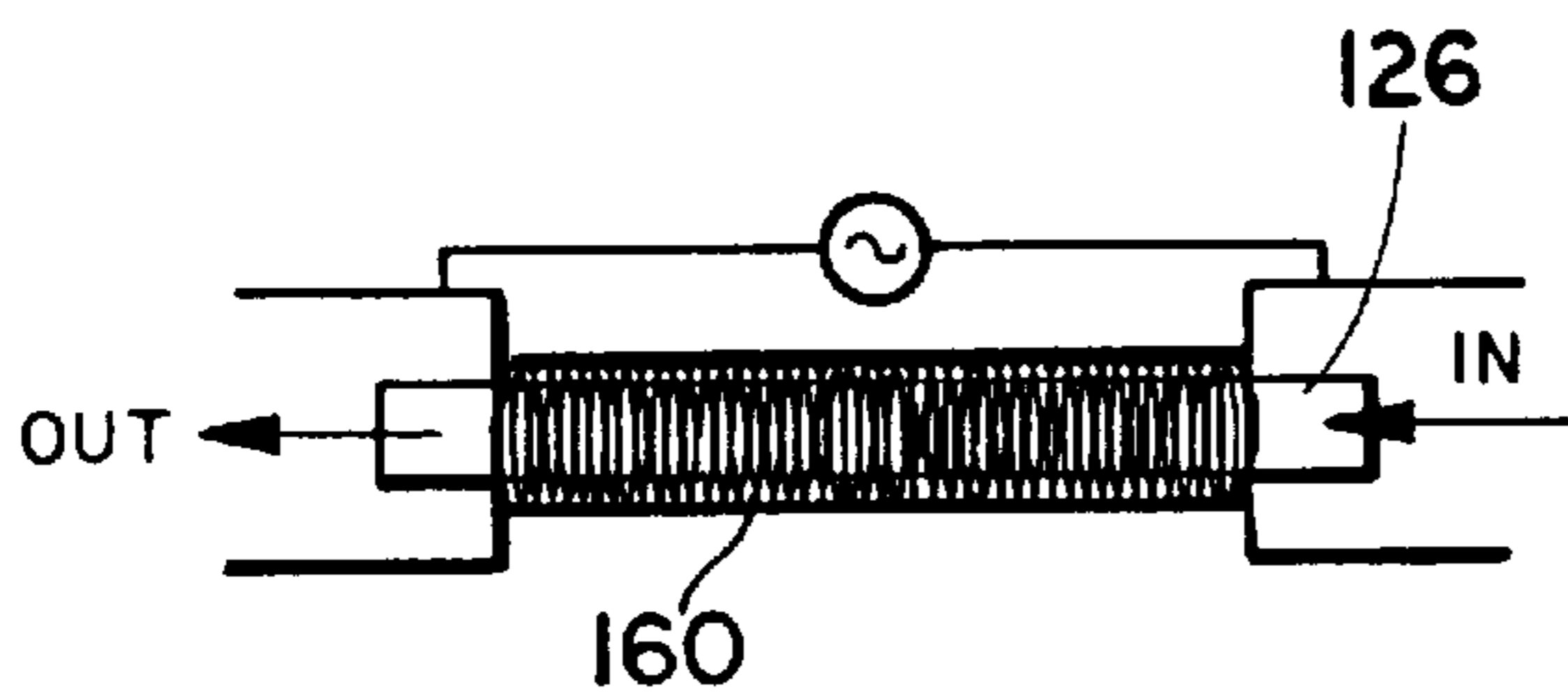

FIG. 13A

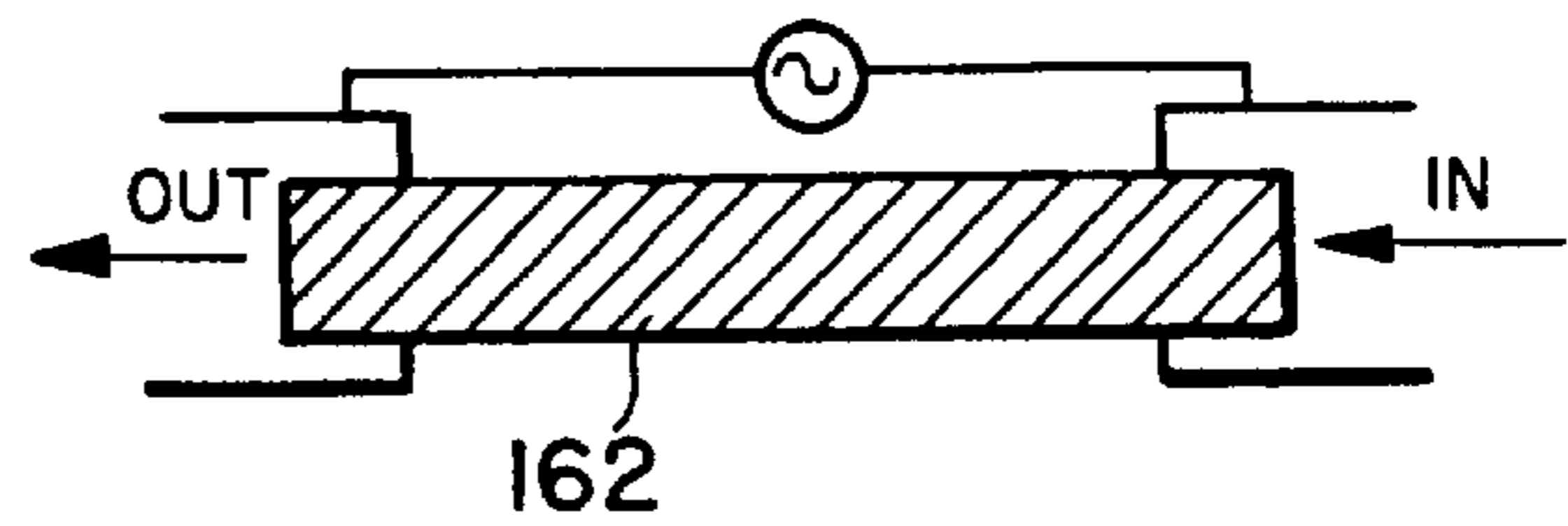

FIG. 13B

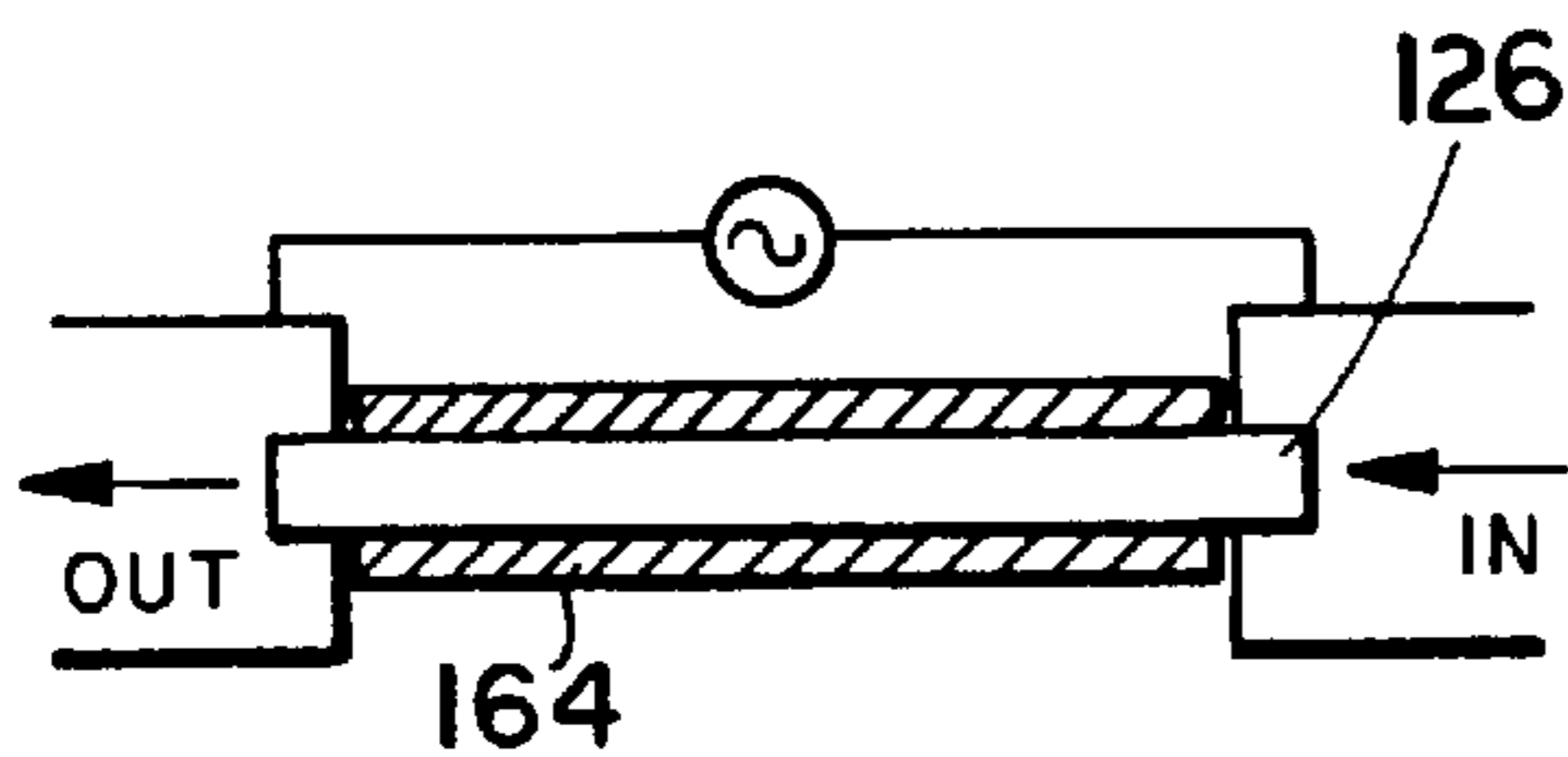

FIG. 13C

ELECTRICAL BREAKDOWN OF AIR AS A FUNCTION OF PRESSURE

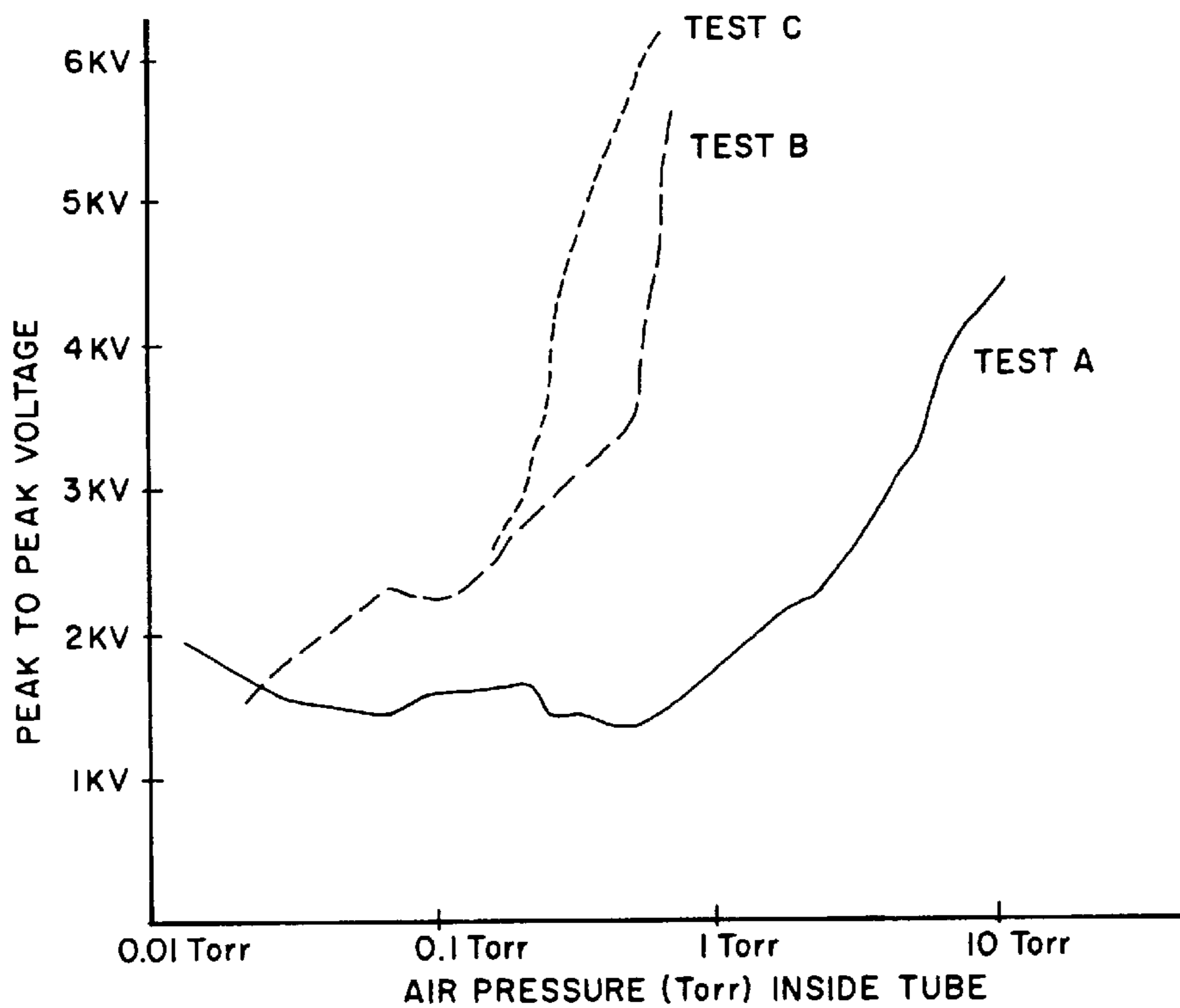

FIG. 15

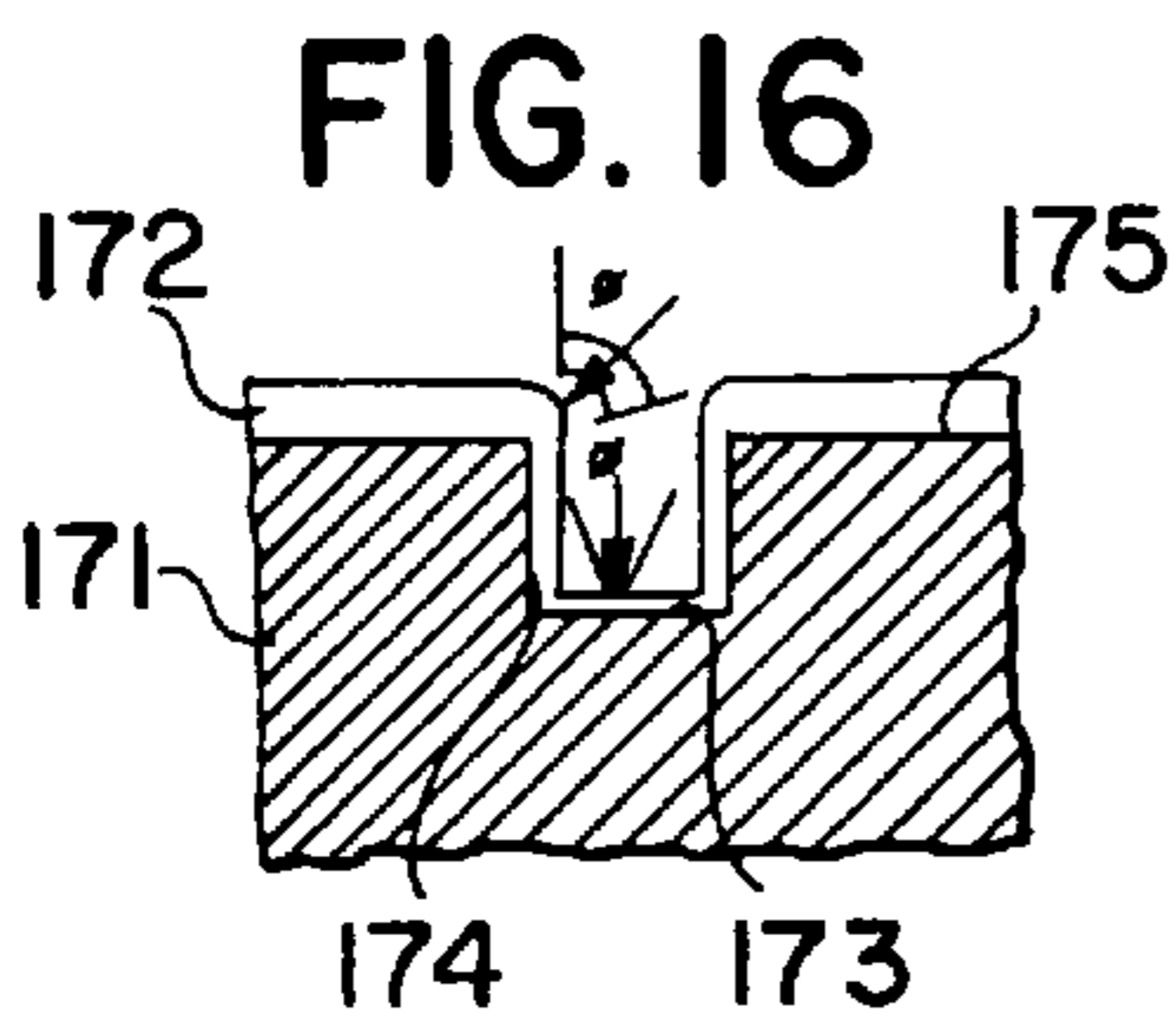

FIG. 16

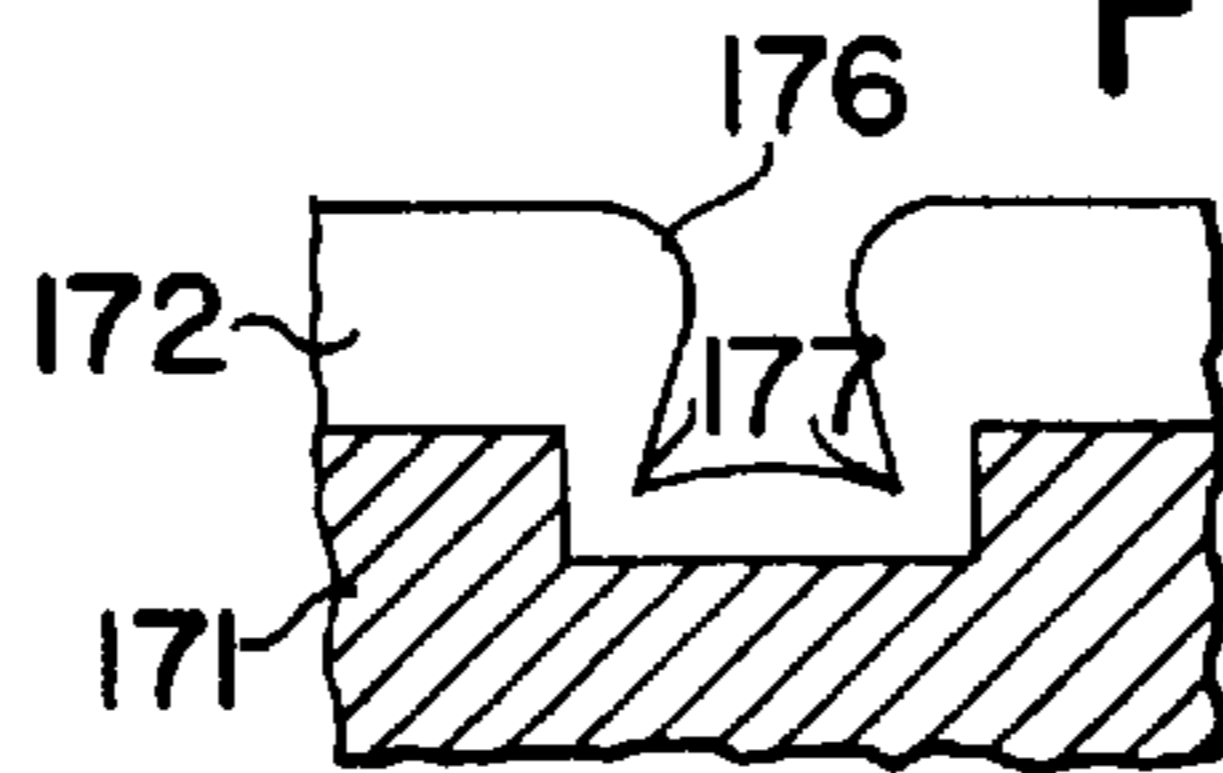

FIG. 17A

PRIOR ART

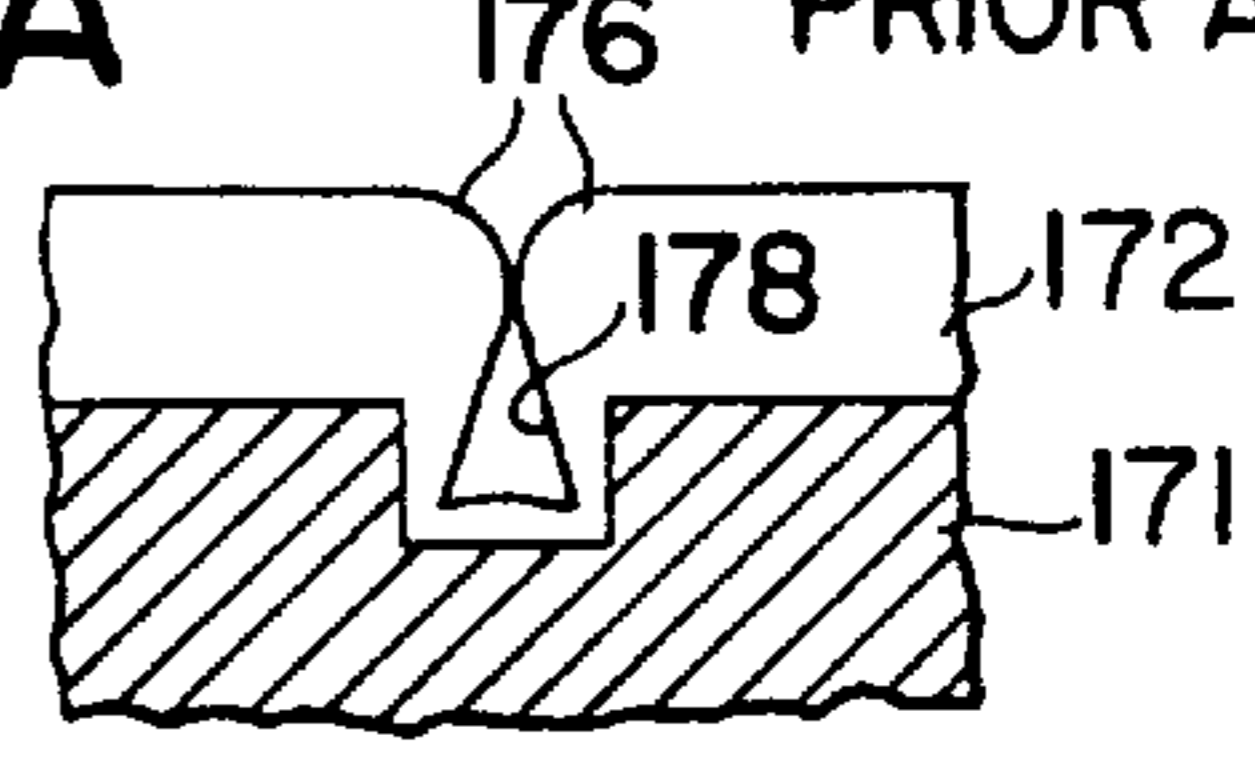

FIG. 17B

PRIOR ART

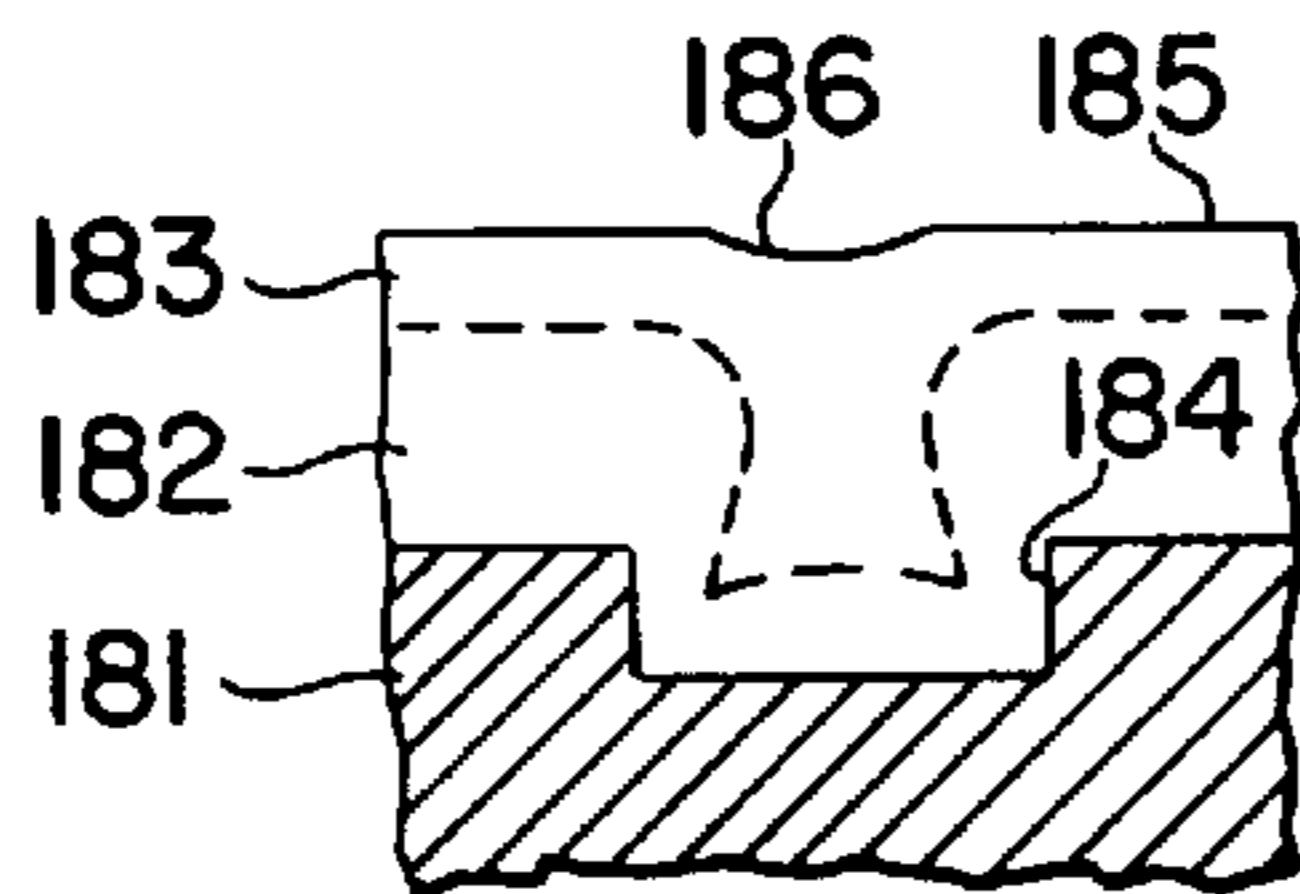

FIG. 18

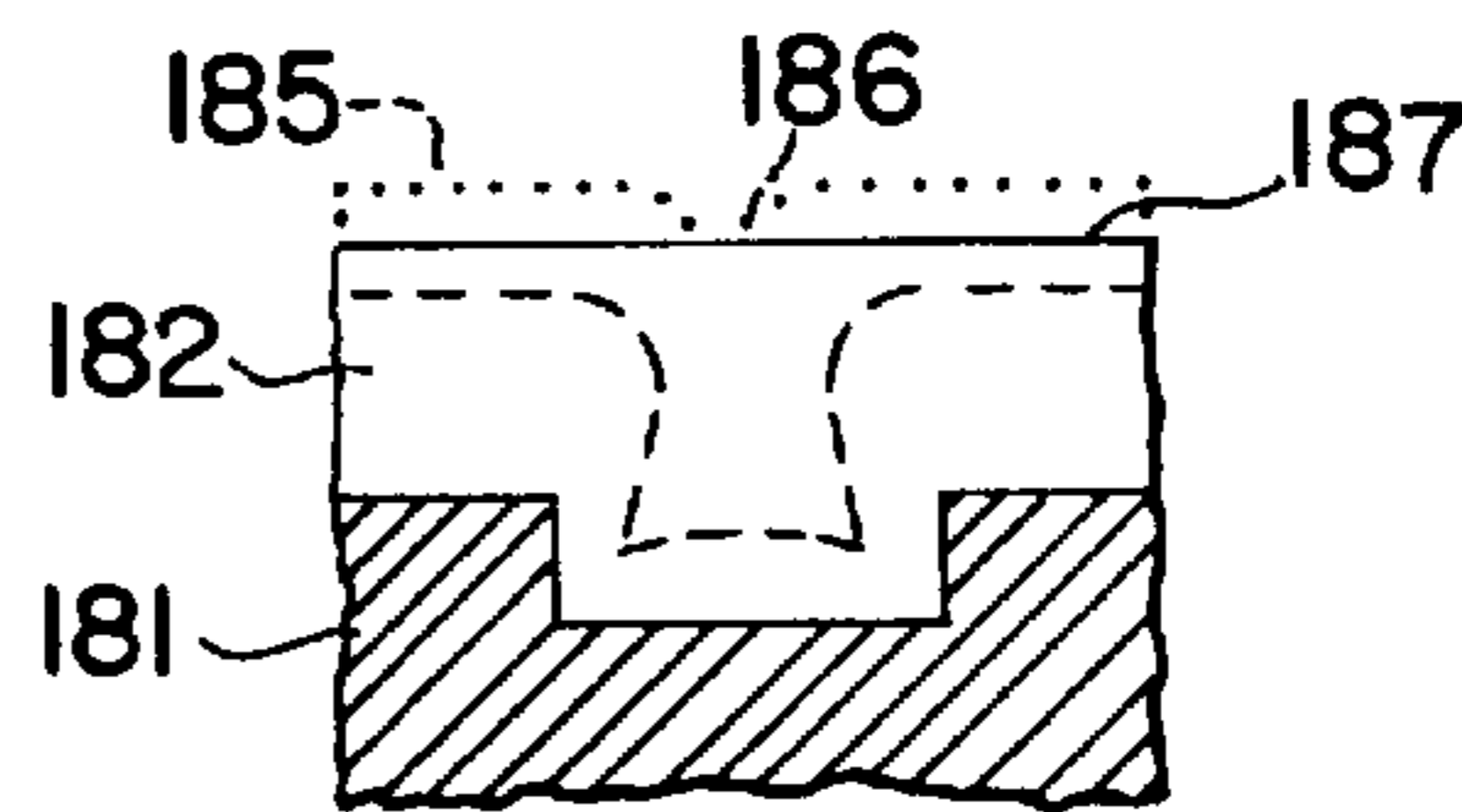

FIG. 19

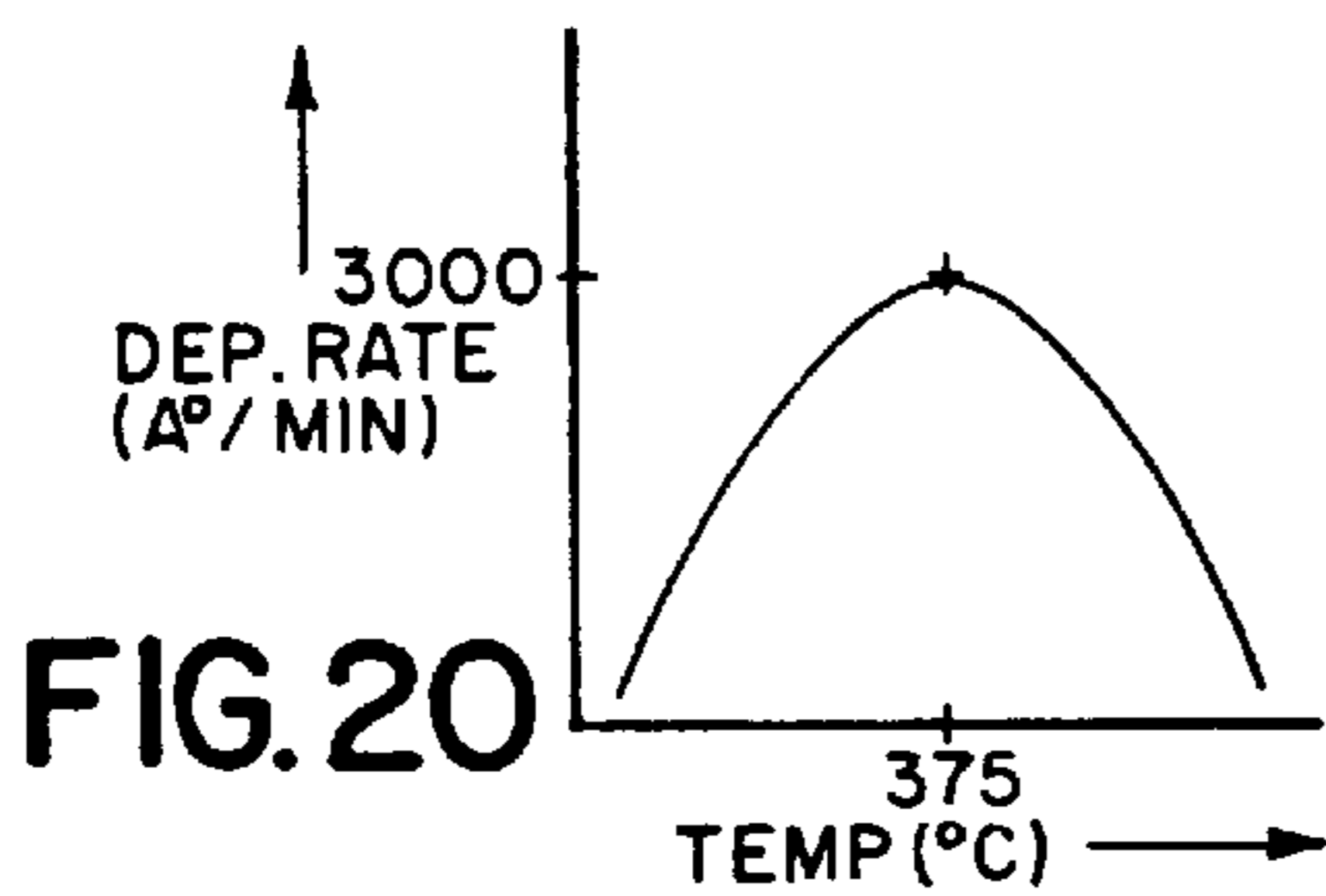

FIG. 20

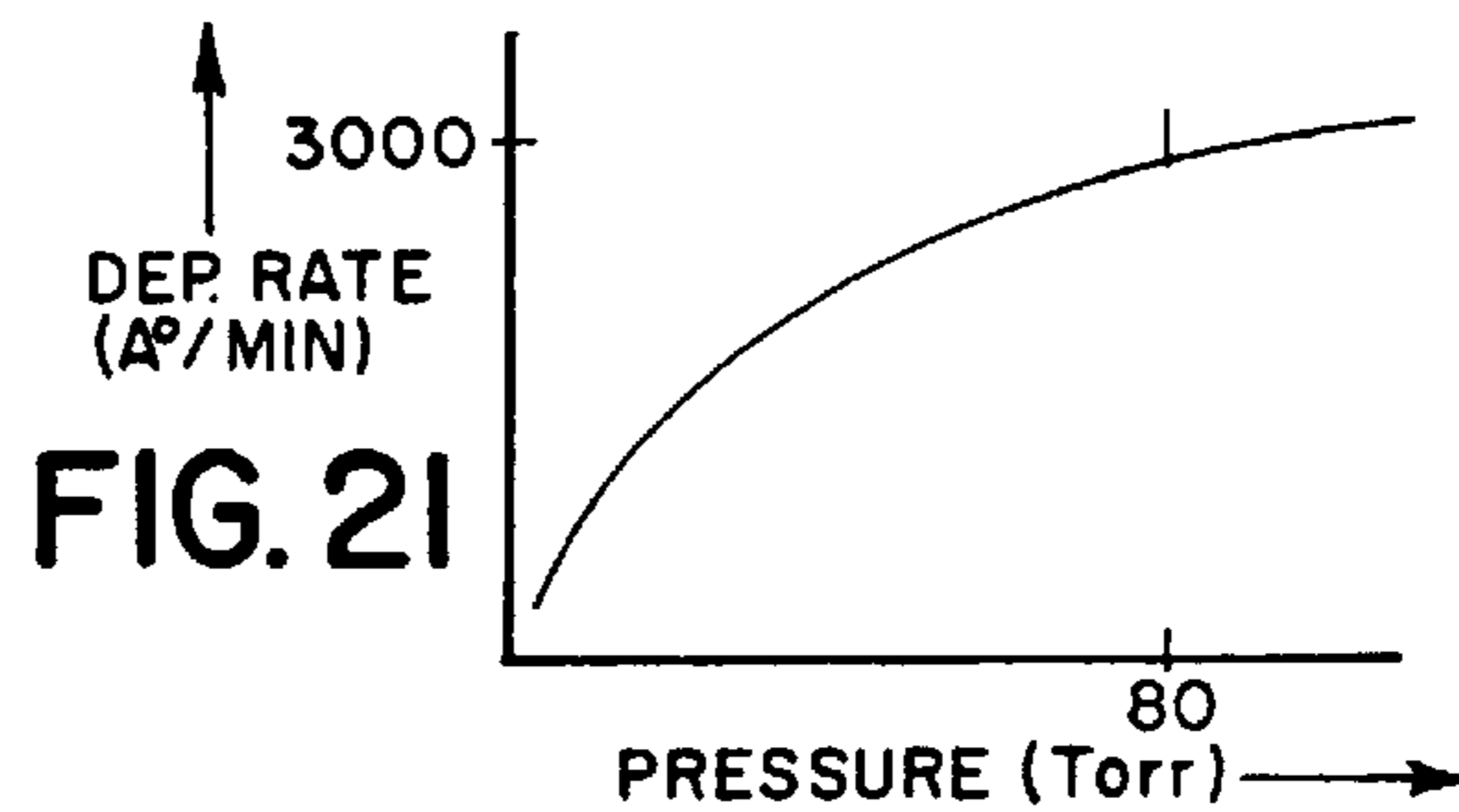

FIG. 21

PROCESS FOR PECVD OF SILICON OXIDE USING TEOS DECOMPOSITION

Matter enclosed in heavy brackets [] appears in the original patent but forms no part of this reissue specification; matter printed in italics indicates the additions made by reissue.

This is a continuation of application Ser. No. 08/407,482 filed on Mar. 18, 1995, abandoned, which application is a continuation of application Ser. No. 07/819,296, filed Jan. 8, 1992, now abandoned, which is a Reissue of Ser. No. 07/262,993 filed Oct. 26, 1988, U.S. Pat. No. 4,892,753 which is a division of application Ser. No. 944,492 filed Dec. 19, 1986, U.S. Pat. No. 5,000,113.

BACKGROUND OF THE INVENTION

The present invention relates to a reactor and methods for performing single and in-situ multiple integrated circuit processing steps, including thermal CVD, plasma-enhanced chemical vapor deposition (PECVD), reactor self-cleaning, film etchback, and modification of profile or other film property by sputtering. The present invention also relates to a process for forming conformal, planar dielectric layers on integrated circuit wafers and to an in-situ multi-step process for forming conformal, planar dielectric layers that are suitable for use as interlevel dielectrics for multi-layer metallization interconnects.

I. Reactor

The early gas chemistry deposition reactors that were applied to semiconductor integrated circuit fabrication used relatively high temperature, thermally-activated chemistry to deposit from a gas onto a heated substrate. Such chemical vapor deposition of a solid onto a surface involves a heterogeneous surface reaction of gaseous species that adsorb onto the surface. The rate of film growth and the film quality depend on the wafer surface temperature and on the gaseous species available.

More recently, low temperature plasma-enhanced deposition and etching techniques have been developed for forming diverse materials, including metals such as aluminum and tungsten, dielectric films such as silicon nitride and silicon dioxide, and semiconductor films such as silicon.

The plasma used in the available plasma-enhanced chemical vapor deposition processes is a low pressure reactant gas discharge which is developed in an RF field. The plasma is, by definition, an electrically neutral ionized gas in which there are equal number densities of electrons and ions. At the relatively low pressures used in PECVD, the discharge is in the "glow" region and the electron energies can be quite high relative to heavy particle energies. The very high electron temperatures increase the density of disassociated species within the plasma which are available for deposition on nearby surfaces (such as substrates). The enhanced supply of reactive free radicals in the PECVD processes makes possible the deposition of dense, good quality films at lower temperatures and at faster deposition rates (300–400 Angstroms per minute) than are typically possible using purely thermally-activated CVD processes (100–200 Angstroms per minute). However, the deposition rates available using conventional plasma-enhanced processes are still relatively low.

Presently, batch-type reactors are used in most commercial PECVD applications. The batch reactors process a relatively large number of wafers at once and, thus, provide relatively high throughput despite the low deposition rates. However, single-wafer reactors have certain advantages,

such as the lack of within-batch uniformity problems, which make such reactors attractive, particularly for large, expensive wafers such as 5–8 inch diameter wafers. In addition, and quite obviously, increasing the deposition rate and throughput of such single wafer reactors would further increase their range of useful applications.

II. Thermal CVD of SiO₂; Planarization Process

Recently, integrated circuit (IC) technology has advanced from large scale integration (LSI) to very large scale integration (VLSI) and is projected to grow to ultra-large integration (ULSI) over the next several years. This advancement in monolithic circuit integration has been made possible by improvements in the manufacturing equipment as well as in the materials and methods used in processing semiconductor wafers into IC chips. However, the incorporation into IC chips of, first, increasingly complex devices and circuits and, second, greater device densities and smaller minimum feature sizes and smaller separations, imposes increasingly stringent requirements on the basic integrated circuit fabrication steps of masking, film formation, doping and etching.

As an example of the increasing complexity, it is projected that, shortly, typical MOS (metal oxide semiconductor) memory circuits will contain two levels of metal interconnect layers, while MOS logic circuits may well use two to three metal interconnect layers and bipolar digital circuits may require three to four such layers. The increasing complexity, thickness/depth and small size of such multiple interconnect levels make it increasingly difficult to fabricate the required conformal, planar interlevel dielectric layers materials such as silicon dioxide that support and electrically isolate such metal interconnect layers.

The difficulty in forming planarized conformal coatings on small stepped surface topographies is illustrated in FIG. 16. There, a first film such as a conductor layer 171 has been formed over the existing stepped topography of a partially completed integrated circuit (not shown) and is undergoing the deposition of an interlayer dielectric layer 172 such as silicon dioxide. This is done preparatory to the formation of a second level conductor layer (not shown). Typically, where the mean-free path of the depositing active species is long compared to the step dimensions and where there is no rapid surface migration, the deposition rates at the bottom 173, the sides 174 and the top 175 of the stepped topography are proportional to the associated arrival angles. The bottom and side arrival angles are a function of and are limited by the depth and small width of the trench. Thus, for very narrow and/or deep geometries the thickness of the bottom layer 173 tends to be deposited to a lesser thickness than is the side layer 174 which, in turn, is less than the thickness of top layer 175.

Increasing the pressure used in the deposition process typically will increase the collision rate of the active species and decrease the mean-free path. This would increase the arrival angles and, thus, increase the deposition rate at the sidewalls 174 and bottom 173 of the trench or step. However, and referring to FIG. 17A, this also increases the arrival angle and associated deposition rate at stepped corners 176.

For steps separated by a wide trench, the resulting inwardly sloping film configuration forms cusps 177–177 at the sidewall-bottom interface. It is difficult to form conformal metal and/or dielectric layers over such topographies. As a consequence, it is necessary to separately planarize the topography.

In addition, and referring to FIG. 17B, where the steps are separated by a narrow trench, for example, in dense 256

kilobit VLSI structures, the increased deposition rate at the corner 176 encloses a void 173. Such voids are exposed by subsequent planarization procedures and may allow the second level conductor to penetrate and run along the void and short the conductors and devices along the void.

SUMMARY OF THE INVENTION

Objects

In view of the above discussion, it is one object to provide a semiconductor processing reactor which provides uniform deposition over a wide range of pressures, including very high pressures.

It is another related object to provide a versatile single wafer semiconductor processing reactor which can be used for a multiplicity of processes including thermal chemical vapor deposition, plasma-enhanced chemical vapor deposition, plasma-assisted etchback, plasma self-cleaning and sputter topography modification, either alone or in-situ in a multiple process sequence.

It is a related object to provide such a reactor which accomplishes the above objectives and also is adapted for using unstable gases such as TEOS and ozone.

It is another object of the present invention to provide a process for forming highly conformal silicon dioxide layers, even over small dimension stepped topographies in VLSI and ULSI devices, using ozone and TEOS gas chemistry and thermal CVD.

It is also an object of the present invention to provide a planarization process which provides excellent conformal coverage and eliminates cusps and voids.

It is still another object of the present invention to provide a planarization process which can be performed in-situ using a multiple number of steps, in the same plasma reactor chamber, by simply changing the associated reactant gas chemistry and operation conditions.

It is yet another object of the present invention to provide an in-situ multiple step process including plasma deposition and isotropic etching of a wafer for the purpose of optimizing coating conformality and planarization, along with process throughput and wafer characteristics such as low particulates.

Another object is to provide the above-described versatile process characteristics along with the ability to vary the process sequence and the number of steps, including but not limited to the addition of reactor self-cleaning.

SUMMARY

In one specific aspect, our invention relates to a semiconductor processing reactor defining a chamber for mounting a wafer therein and an inlet gas manifold for supplying reactant gases to the wafer. The chamber also incorporates a uniform radial pumping system which includes vacuum exhaust pump means; a gas distributor plate mounted peripherally about the wafer mounting position within the chamber and including a circular array of exhaust holes therein; and a circular channel beneath and communicating with the hole array and having at least a single point connection to the vacuum exhaust pump for flowing gases radially from the inlet manifold across the wafer and through the exhaust port. The channel is of sufficiently large volume and conductance relative to the holes to enable controlled uniform radial gas flow across the wafer to the exhaust holes, thereby promoting uniform flow and processing (etching and deposition) over a wide range of pressures, including very high pressures up to about one atmosphere.

In another aspect, the present invention is directed to a semiconductor processing reactor which comprises a housing forming a chamber for mounting a wafer horizontally, a vacuum exhaust pumping system communicating with the chamber, and an inlet gas manifold oriented horizontally over the wafer mounting position. The manifold has a central array of process gas apertures configured for dispensing reactant gas uniformly over the wafer and a second peripheral array of purging gas apertures configured for directing purging gas downward to the periphery of the wafer. The hole arrays are also arranged to eliminate radial alignment of holes.

In another aspect, the reactor incorporates a system for circulating fluid of controlled temperature within the manifold for maintaining the internal surfaces within a selected temperature range to prevent condensation and reactions within the manifold and for maintaining the external manifold surfaces above a selected temperature range for eliminating unwanted deposition thereon.

In still another aspect, the reactor of the present invention comprises a thin susceptor for supporting a wafer, susceptor support means for mounting the susceptor in a horizontal position precisely parallel to the gas inlet manifold and means for selectively moving the wafer support means vertically to position the susceptor and support parallel to the gas manifold at selected variable-distance positions closely adjacent the gas manifold. In particular, the variable parallel close spacing can be 0.5 centimeter and smaller.

In still another aspect, the semiconductor processing reactor of the present invention comprises a housing defining a chamber therein adapted for the gas chemistry processing of a wafer positioned within the chamber. A transparent window forms the bottom of the chamber. A thin high emissivity susceptor is used for supporting a wafer within the chamber. A radiant heating module comprising a circular array of lamps mounted in a reflector module is mounted outside the housing for directing a substantially collimated beam of near-infrared radiant energy through the window onto the susceptor with an incident power density substantially higher at the edge of the susceptor than at the center thereof, to heat the wafer uniformly.

Preferably, a second, purge gas manifold is positioned beneath the wafer processing area for providing purging gas flow across the window and upward and across the bottom of the wafer. The combination of the high pressure, the purge flow from the inlet gas manifold and that from the purge gas manifold substantially eliminates deposition on chamber surfaces.

In still another aspect, the reactor of the present invention comprises a deposition gas feed-through device connected to the gas inlet manifold which comprises tube means adapted for providing co-axial flow of deposition gas on the inside of the tube and purge gas on the outside thereof into the gas inlet manifold. The tube is adapted for connection to ground at the inlet end and to an RF power supply at the outlet or manifold end to provide RF power to the manifold, and has a controlled electrical impedance along its length from the inlet to the outlet end for establishing a constant voltage gradient to prevent breakdown of the gas even at high RF frequencies and voltages.

These and other features discussed below permit reactor operation over a wide pressure regime, that is, over a wide of pressures including high pressures up to approximately one atmosphere. The features also provide uniform susceptor and wafer temperatures, including both absolute temperature uniformity and spatial uniformity across the

susceptor/wafer; uniform gas flow distribution across the wafer; and effective purging. The variable parallel close spacing between the electrodes adapts the reactor to various processes. These features and the temperature control of the internal and external gas manifold temperatures enable the advantageous use of very sensitive unstable gases such as ozone and TEOS in processes such as the following.

That is, the present invention also relates to a method for depositing a conformal layer of silicon dioxide onto a substrate by exposing the substrate to a reactive species formed from ozone, oxygen, tetraethylorthosilicate, and a carrier gas within a vacuum chamber, using a total gas pressure within the chamber 10 torr to 200 torr and a substrate temperature within the range of about 200° C. to 500° C. Preferably, a substrate temperature of about 375° C. ±20° C. is used to obtain maximum deposition rates and the chamber pressure is about 40 torr to 120 torr.

In still another aspect, the present invention is embodied in a method for depositing silicon dioxide onto a film or substrate by exposing the substrate to the plasma formed from tetraethylorthosilicate, oxygen and a carrier gas in a chamber using a total gas pressure within the range of about 1 to 50 torr, and a substrate temperature in the range of about 200° C. to 500° C. Preferably, the chamber pressure is 8–12 torr and the substrate temperature is about 375° C. ±20° C.

In still another aspect, the invention is directed to a method for isotropically etching a silicon dioxide surface comprising the step of exposing a silicon dioxide surface to a plasma formed from fluorinate gas such as NF_3 , CF_4 and C_2F_6 in a carrier gas in a chamber using a wafer temperature in the range of from about 200° C. to 500° C. Preferably, the chamber pressure is within the range of about 200 mT to 20 torr, and 500 mT to 10 torr. The invention is also embodied in a method for planarizing a non-planar dielectric coating or composite within a vacuum chamber by depositing a conformal layer of silicon dioxide onto the coating by exposing the coating to a reactive species formed from ozone, oxygen, tetraethylorthosilicate and a carrier gas, the total chamber gas pressure being within the approximate range 10 torr to 200 torr and the substrate temperature being within the approximate range 200° C. to 500° C., to thereby form a composite of the conformal layer on the substrate; and isotropically etching the outer surface of the resulting composite layer. Preferably, this planarizing process uses the plasma oxide deposition to first form a layer of silicon oxide and also uses the isotropic etch described above.

BRIEF DESCRIPTION OF THE DRAWINGS

The above and other aspects and advantages of the present invention are described in conjunction with the following drawing figures, in which:

FIG. 1 is a top plan view of a preferred embodiment of the combined CVD/PECVD reactor of the present invention, shown with the cover pivoted open;

FIG. 2 is a vertical cross-section, partly in schematic, taken along line 2—2 in FIG. 1, with the reactor cover closed;

FIG. 3 is a vertical cross-section through the wafer elevator mechanism, taken along line 3—3 in FIG. 1;

FIGS. 4–8 are sequential, highly schematized representations of the operation of the wafer transport system in positioning wafers within, and removing wafers from the reactor susceptor;

FIG. 9 is a reduced scale, horizontal cross-section through the circular-array, radiant lamp heating assembly, taken along line 9—9 in FIG. 2;

FIG. 10 is an enlarged, partial depiction of FIG. 2 showing the process gas and purge gas distribution systems in greater detail;

FIG. 11 is a partial, enlarged bottom plan view of the gas distribution head or manifold;

FIG. 12 depicts an enlarged, vertical cross-section of the RF/gas feed-through system shown in FIG. 2;

FIGS. 13A–13C schematically depict various alternative embodiments of the gas feed-through;

FIG. 14 illustrates breakdown voltage as a function of pressure for low frequency and high frequency RF power without a constant voltage gradient device;

FIG. 15 illustrates breakdown voltage as a function of pressure with and without a constant voltage gradient device;

FIG. 16 is a schematic cross-sectional representation of an integrated circuit which illustrates the arrival angles associated with the deposition of a layer of material such as dielectric onto a surface of stepped topography;

FIGS. 17A and 17B are schematic cross-sections, similar to FIG. 16, which illustrate the effect of trench width on planarization;

FIGS. 18 and 19 are cross-sections of the surface topology of an integrated circuit, in the manner of FIG. 16, illustrating the conformal, planar qualities of oxide films resulting from the application of our planarization process; and

FIGS. 20 and 21 depict the deposition rate as a function of temperature and pressure, respectively, for our present oxide deposition process.

DETAILED DESCRIPTION OF THE INVENTION

I. CVD/PECVD Reactor

A. Overview of CVD/PECVD Reactor

FIGS. 1 and 2 are, respectively, a top plan view of the preferred embodiment of the single wafer, reactor 10 of our present invention, shown with the cover pivoted open, and a vertical cross-section of the reactor 10.

Referring primarily to these two figures and to others indicated parenthetically, the reactor system 10 comprises a housing 12 (also termed a “chamber”), typically made of aluminum, which defines an inner vacuum chamber 13 that has a plasma processing region 14 (FIG. 6). The reactor system 10 also includes a wafer-holding susceptor 16 and a unique wafer transport system 18 (FIG. 1) that includes vertically movable wafer support fingers 20 and susceptor support fingers 22. These fingers cooperate with an external robotic blade 24 (FIG. 1) for introducing wafers 15 into the process region or chamber 14 and depositing the wafers 15 on the susceptor 16 for processing, then removing the wafers 15 from the susceptor 16 and the chamber 12. The reactor system 10 further comprises a process/purge gas manifold or “box” 26 that applies process gas and purging gas to the chamber 13, an RF power supply and matching network 28 for creating and sustaining a process gas plasma from the inlet gas and a lamp heating system 30 for heating the susceptor 16 and wafer 15 positioned on the susceptor to effect deposition onto the wafer. Preferably, high frequency RF power of 13.56 MHz is used, but low frequencies can be used.

The gas manifold 26 is part of a unique process and purge gas distribution system 32 (FIGS. 2 and 10) that is designed to flow the process gas evenly radially outwardly across the wafer 15 to promote even deposition across the wafer and to

purge the spent gas and entrained products radially outwardly from the edge of the wafer 15 at both the top and bottom thereof to substantially eliminate deposition on (and within) the gas manifold or box 26 and the chamber 12.

A liquid cooling system 34 controls the temperature of the components of the chamber 12 including, in particular, the temperature of the gas manifold or box 26. The temperature of the gas box components is selected to eliminate premature deposition within the gas box/manifold 26 upstream from the process chamber 14.

The reactor system 10 includes a unique, RF/gas feed-through device 36 (FIGS. 2 and 12) that supplies process and purge gas to the RF-driven gas manifold 26 from an electrically ground supply. Applying the RF energy to the gas box or manifold 26 has the advantage of the wafer residing on the grounded counter electrode or susceptor 16, which makes possible a high degree of plasma confinement that would not be achievable if the RF energy were applied to the wafer and the gas box were grounded. Additionally, the hardware is mechanically and electrically simpler since electrical isolation between wafer/susceptor and chamber is not required (or permitted). Temperature measurement and control of the susceptor/wafer in the presence of high frequency electric and magnetic fields is greatly simplified with the susceptor 16 grounded. Also, the feed-through 36 is rigid, eliminating flexible gas connections and the purge gas flow path safely carries any leaking process gas into the chamber to the chamber exhaust. The capability to apply RF power to the gas manifold is made possible (despite the inherent tendency of high potential RF operation to form a deposition plasma within the feed-through) by the unique design of the feed-through, which drops the RF potential evenly along the length of the feed-through, thus preventing a plasma discharge within.

B. Wafer Transport System 18

As mentioned, this system is designed to transfer individual wafers 15 between the external blade, FIG. 2, and the susceptor 16 and to position the susceptor 16 and wafer 15 for processing. Referring further to FIG. 1, the wafer transport system 18 comprises a plurality of radially-extending wafer-support fingers 20 which are aligned with and spaced about the periphery of susceptor 16 and are mounted to a semi-circular mounting bar or bracket 38. Similarly, an array of radially-extending susceptor-support fingers 22 are spaced circumferentially about the susceptor 16, interdigitated with the wafer support fingers 20, and are mounted to a semi-circular bar 40 positioned just outside bar 38. The arcuate mounting bars 38 and 40 are mounted within a generally semi-circular groove 42 formed in the housing, and are actuated respectively, by vertically movable elevator assemblies 44 and 46.

As shown in FIG. 3, the susceptor elevator mechanism 44 includes a vertically movable shaft 48 that mounts the bar 38 at the upper end thereof. The shaft can be moved vertically up and down by various moving means 56, including a pneumatic cylinder, or, preferably, a stepper motor operating via suitable gear drive. Wafer elevator mechanism 46 is similar to the elevator 44.

The operation of the wafer transport system 18 is summarized by the sequence depicted schematically in FIGS. 4-8. In FIG. 4 the external blade 24 (with the wafer 15 to be processed supported thereon) is inserted via opening 56 into chamber 13 to a position over the susceptor 16. One example of a suitable blade 24 and associated robot wafer handling system (and door 25, FIG. 6) is described in co-pending, commonly assigned U.S. patent application Ser. No. 944,

803, entitled "Multiple Chamber Integrated Process System", filed concurrently in the name of Dan Maydan, Sasson Somekh, David N. K. Wang, David Cheng, Massato Toshima, Isaac Harari, and Peter Hoppe which application is hereby incorporated by reference in its entirety. In this starting position, the wafer fingers 20-20 are positioned between the susceptor 16 and the blade 24. Next, as shown in FIG. 5, the wafer elevator mechanism 44 the wafer-support fingers 20-20 above the blade 24 to pick up the wafer 15. The blade 24 is then withdrawn from the chamber 13.

As shown in FIG. 6, after retraction of the blade 24, a pneumatic cylinder closes door 25 over the blade access slot 56 to seal chamber 13. The susceptor elevator mechanism 46 is actuated to raise the susceptor-support fingers 22 and susceptor 16 so that the susceptor 16 lifts the wafer 15 from the fingers 20-20 into position for processing in the area 14 immediately adjacent the gas distribution manifold 26. The spacing, d, between the wafer 15 and manifold 26 is readily selected by adjusting the travel of the elevator 46. At the same time, the susceptor rings 22 and elevator mounting 46 maintains the horizontal orientation of the susceptor 16 and wafer 15 and parallelism between the wafer 15 and manifold 26 independent of the spacing, d.

After processing, and referring to FIG. 7, the susceptor elevator mechanism 46 lowers the susceptor fingers 22 and the susceptor 16 to deposit the wafer 15 on the wafer support fingers 20-20. The door 25 is then opened and blade 24 is again inserted into the chamber 13. Next, as shown in FIG. 8, elevator mechanism 44 lowers the wafer-support fingers 20-20 to deposit the wafer 15 on the blade 24. After the downwardly moving fingers 20-20 clear the blade 24, the blade is retracted, leaving the fingers 20 and 22 in the position shown in FIG. 4 preparatory to another wafer insertion, processing and withdrawal cycle.

C. Near-IR Radiant Heating System 30

The radiant heating system shown in FIGS. 2 and 9 provides a reliable, efficient and inexpensive means for heating the circular susceptor 16 and wafer 15 (e.g., silicon) in a manner that provides uniform wafer temperature, accurate absolute wafer temperature and rapid thermal response at low temperatures, preferably $\leq 600^\circ\text{C}$. In achieving these objectives, a number of requirements must be met. First, achieving uniform wafer temperature requires compensating the radiation losses at the edge of the wafer. Secondly, high efficiency at low wafer temperatures ($\leq 600^\circ\text{C}$) requires a high emissivity, high thermal conductivity susceptor 16 because silicon wafers have low emissivity at low temperatures in the near-infrared spectrum. In addition, near-infrared radiation is used to obtain fast heating response and for transmission through the inexpensive materials such as quartz window 70. The circular thin susceptor 16 is low thermal capacitance for fast heating and cooling response. These and the other objectives discussed below are achieved by the radiation heating system 30 shown in FIGS. 2 and 9.

The heating system 30 preferably comprises an annular array of small, inexpensive, single-ended vertically oriented lamps 58-58 which provide radiation in the near-infrared portion of the electromagnetic spectrum. The lamps 58-58 are mounted within an annular circular reflector module 60, preferably of aluminum. The module base 60 is formed from a block of aluminum, and has a polished annular reflecting channel 62 machined therein. The channel 62 has an arcuate, generally semi-circular reflecting base 64. The module 60 and lamps 58-58 are cooled by an annular cooling passage 66 that is formed within the collimating annular reflector 62.

Connections are provided for the inlet and outlet of cooling liquid which, typically, is chilled water from a pressurized supply. Power is supplied to the lamp sockets **63** and associated lamps **58** by an electrical supply cable **68**, typically from a variable power supply which automatically varies the lamp power based upon a predetermined program setting that is adapted to the requirements of the particular deposition process.

The annularly-collimated light from the vertical oriented lamps **58—58** is admitted into the chamber via a quartz window **70**. Quartz is transparent to near-IR radiation. The transparent quartz window **70** is mounted to the housing **13** at the bottom of the process chamber **13** using annular seals **72—72** to provide a vacuum-tight interface between the window **70** and the housing. This mounting arrangement positions the radiant energy heating source **30** outside the chamber **13** at atmospheric pressure and isolates the vacuum of the processing chamber and the particulate-sensitive processing therein from the lamps. A bracket **74** can be joined to the lamp mounting base **60** and pivotally mounted by pivot pin **76** to a mating bracket **78**, which is joined to the housing **12**. (Alternatively, the lamp module can be bolted in place.) As a consequence of this pivotal mounting of the lamp assembly **30** external to and isolated from the process chamber **13**, the lamp assembly is readily accessible for maintenance, lamp replacement, etc., by simply disengaging a clamp **79** to allow the assembly to pivot downwardly about pin **76**.

As mentioned, the lamps **58—58** are small single-ended commercially available quartz-tungsten-halogen lamps which provide the required near-infrared radiation. One suitable lamp is the Ansi type “FEL” supplied by Sylvania, G.E., Ushio or Phillips. Presently, fourteen 0.5 to 1 kilowatt quartz-tungsten-halogen lamps that provide a wavelength of about 0.9 to 1.5 micron provide an annularly-collimated power density of up to about 94 W/cm² at the top of the lamp module. The maximum power density at the susceptor (substantially directed to the outer ~1.5 in. radius of a 6 in. diameter susceptor) is ~17 W/cm² taking all efficiency into account (~15–16% efficiency). More generally, lamps concentrating their radiation in the range of about 0.7 to 2.5 microns wavelength would be particularly useful. The aluminum base **60** and concave-bottom, annular groove **62** provide a high collection-efficiency collimating reflector which directs a higher radiation power density at the susceptor edge than at the middle. This non-uniform, concentrated radiation heats the susceptor wafer circumferentially, which compensates the wafer edge heat losses and, thus, provides uniform wafer temperature over a wide range of chamber gas pressures and wafer temperatures

In short, the desired uniform radiant wafer heating is provided by small, inexpensive lamps mounted in a compact simple aluminum module **60** that is easily cooled and maintained at a low temperature, and does not require plating. In addition, the use of the near-IR lamps and a thin, low mass, low thermal capacity, high emissivity susceptor of material such as graphite, provides maximum efficiency, fast thermal response, excellent temperature uniformity and transmission through the quartz window **70**. Other susceptor materials include anodized aluminum, graphite coated with layers such as aluminum oxide (Al₂O₃) or silicon carbide, or a composite ceramic coated with Al₂O₃ or SiC or other materials. Also, interchangeable modules **60** having channels of different heights or diameters can be used to accommodate different susceptor and wafer diameters. A present version of the reactor is designed for 5–6 in. wafers. However, different lamp modules can be provided for

smaller or larger diameter wafers by changing the module height and/or the radius of the module and the filament circle. Finally, the heating system **30** may employ a controller (not shown) such as a closed loop temperature control system using phase angle power control to provide rapid thermal response and rapid wafer temperature stability.

It should be noted that the simplicity, low mass and high performance characteristics of the heating system **30** are in contrast to prior wafer heating approaches which typically use a rectangular array of double-ended quartz-tungsten-halogen lamps. Conventional radiation heating practice has been to use a more massive susceptor and, if excellent temperature uniformity is required, to merely block radiation from the wafer center, thus sacrificing efficiency, rather than redirecting radiation. The advantages of the radiant heating system **30** over the conventional practices include in addition to the aforementioned uniform wafer temperature and much faster response time (both heating and cooling), smaller, less bulky more easily maintained equipment of higher reliability (long lamp lifetime); more efficient operation; and lower cost.

The use of the easily accessible, external radiant heat source **30** is facilitated and maintained by a gas purge system. As described in the succeeding section, this system directs purge gas flow across the vacuum side of the quartz window **70** to prevent deposition on the window and keep the window clean. Thus, the purge is a major contributor to lamp efficiency. This increases the number of process cycles between cleaning and, as a result, decreases the associated system downtime required for cleaning.

D. Gas Manifold **26** and Associated Distribution System

The gas distribution system **32** is structured to provide a unique combination of at least four structural features. First, the gas manifold **26** is one-half (the powered half) of an electrode pair. The powered manifold **26** provides high power. Second, the gas manifold **26** and other gas distribution surfaces are temperature controlled, which contributes to uniform deposition on the wafer **15** and prevents gas decomposition, deposition or condensation within the gas distribution system upstream from the plasma processing area **14** despite the use of reactant gases such as TEOS which condenses at ~35° C. and decomposes or reacts with ozone at ~75° C. The external manifold temperature is controlled, e.g., to >100° C., to prevent the deposition of flaky, particulate-causing deposits. Third, the gas manifold **26** and gas distribution system **32** provide a clean, uniform deposition process. Fourth, the incorporated circumferential purging gas flow prevents deposition outside of the gas distribution area, i.e., outside the wafer on the internal chamber surfaces and gas distribution system surfaces.

The above features of gas distribution system **32** are depicted most clearly in the FIG. 2 vertical section view and the FIG. 10 enlarged vertical section view. The gas manifold **26** and associated distribution system are part of the housing cover **80**, which is pivotally mounted to the housing **12** by pivot means (not shown) to facilitate access to the interior of the housing, including chamber **13**, plasma process chamber **14**, and associated internal components of the wafer and susceptor elevator mechanisms (**44,46**).

The process gas flow from the feed-through **36** is directed into the cover **80** by inlet bore **88** which communicates with, that is, feeds into, gas manifold chamber **90** formed by the apertured manifold face plate **92**. A uniquely designed baffle plate **94** is mounted within the gas manifold chamber **90** by means such as standoffs (not shown) to route the process gas around the outside of the edge of the baffle **94** and then

radially inwardly along the bottom of the baffle and out the apertures 96—96 in the manifold plate into the plasma processing region 14 above wafer 15.

The cover 80, including the manifold 26 thereof, is heated (or cooled) by an internal flow of fluid or liquid such as de-ionized water along internal path 81 defined by inlet channel 82, annular channel 84 and outlet channel 86. Preferably, this flow keeps the face plate 92 within the range 100° C.—200° C., in order to ensure that any deposition on the face of the gas manifold which is exposed to the plasma is a hard film. A poor film formed on this surface can create particulates and this must be avoided. Also, the flow preferably holds baffle 94 within the range, most preferably within 35° C.—65° C., to prevent internal deposition or condensation of low vapor pressure process gases such as TEOS and to prevent decomposition and reactions of gases such as TEOS and ozone. Please note, such deposition is directly proportional to time, temperature (t,T). Thus, the very small gap “d” of about 0.1 to 0.2 inches between the plates 94 and 92 also decreases any tendency to internal deposition.

As an example, in one process application involving the deposition of silicon dioxide, oxygen, TEOS and a carrier gas are inlet from manifold 26 to the chamber 14 at chamber pressure of 0.5–200 torr to form a reactant species for deposition. Wafer 15 is heated to 375° C., and hot de-ionized water (water temperature 40° C. to 65° C.) is inlet along path 81 at an adequate flow to keep plate 92 at <65° C., to prevent condensation of the TEOS, and to keep plate 94 >100° C. (De-ionized water is used because the manifold 26 is the RF powered cathode and de-ionized water is a nonconductor.) More generally, the inlet temperature of the water is selected as required for a particular deposition process and its associated gas chemistry and/or other parameters in order to maintain both the internal surfaces and the external surfaces of the gas box 90 at desired temperatures.

To reiterate, the process gas flow is along path 91 defined through inlet bore 88, into manifold chamber 90, radially outwardly to the edge of baffle 94 and around the baffle periphery to the bottom thereof, then radially inwardly between the baffle 94 and the manifold plate 96 and out holes 96—96 into the plasma processing region 14 above the wafer 15. The flow path of the deposition gas emerging from holes 96—96 is generally radially outwardly across the wafer.

In addition, the small volume of the vacuum process chamber 14 and the high useful chamber pressure range of about 0.5 torr to near-atmospheric pressure also contribute to the tendency to provide a uniform flow radially outward from the center of the wafer 15 with uniform deposition on the wafer and purging without deposition other than on the wafer.

The manifold holes 96—96 are designed to promote this uniformity of deposition. The holes (as well as the manifold temperature, discussed above) are also designed to avoid the formation of deposits on the manifold outer (bottom) surface 97 and, in particular, to prevent the deposition of soft deposits on surface 97 which could flake off and drop onto the wafer during and after processing. Briefly, the hole array is one of generally concentric rings of holes 96—96. The distances between adjacent rings (ring-to-ring spacings) are approximately equal, and the hole-to-hole spacing within each ring is approximately equal. However, the patterns are angularly staggered so that no more than two adjacent holes (or some other selected number) are aligned radially. That is, the holes in the gas distribution plate 92 are equally spaced

on circles so the hole locations do not form radial straight lines, thereby substantially decreasing deposition on the gas distribution plate itself and enabling uniform gas flow and deposition on the wafer.

The hole length through the manifold 92, i.e., the thickness of the manifold plate 92, and the transverse hole diameter are also selected to promote uniform deposition. Increasing/decreasing the hole length has the effect of decreasing the deposition thickness inside-out/outside-in, as does increasing/decreasing the hole diameter.

In a presently used configuration, approximately 3400 holes 96—96 are used. The hole length is 0.100 to 0.150 in., the hole diameter is 0.028 to 0.035 in. and the radially asymmetric holes are located on approximately 0.090 in. centers. These dimensions and the associated configuration provide a uniform flow pattern and substantially decrease deposition on the manifold plate 92. The present ~6 in. manifold diameter will accommodate wafer diameters as large as ~6 in. Larger wafers can be processed by changing to a larger manifold 26, susceptor 16, larger diameter susceptor 16 and wafer support finger arrays, and by altering the lamp module 30 as described previously.

Referring further to FIG. 10, as indicated by the arrows 93, 95, 97 a first, upper purge gas flow path is provided in cover 80 and manifold 26. That is, purge gas flow from the RF/gas feed-through 36 is routed into inlet bore 98 in cover 80 (arrow 93) which feeds into radial channels or grooves 100 that in turn feed into an annular groove 102 formed in the cover concentric with and just above and outside the manifold chamber 90 (arrow 95). A ring flow turner 104 is mounted concentrically within manifold plate rim 105 and forms a peripheral channel 106 at the inside of the manifold rim that connects the annular channel 102 to the three outer rows of apertures 108 in the manifold plate 92.

As shown in FIG. 11, the purge holes 108—108 are arranged similarly to the process gas holes 106—106 in generally concentric rings that are spaced at approximately equal ring-to-ring distances. The within-ring hole spacing is selected so that the locations of the purge holes 108—108 form staggered radial lines, i.e., so that no two adjacent purge holes are along a radial line. For the above-described exemplary manifold, the gas is distributed from about 600 holes and the following purge hole dimensions are used: between-ring spacing 0.090 in.; hole diameter 0.025 in.; and hole length 0.040 in.

Referring to FIG. 2, a second, lower purge flow path 101, 103, 105 is provided via inlet bore 110, formed in the side of the housing 12, which connects or feeds into an annular channel 112 formed generally concentrically about the lower section of the process chamber 13 just above the quartz window 70. The channel 112 has holes that are spaced about the lower region of the chamber 13 or equivalent yielding feature to feed the lower purge gas uniformly across the quartz window 70 (see arrows 103), around the lower edge of the wafer 15 (arrows 105) and across horizontal quartz cover plate 114, which surrounds the chamber 13 just below the wafer processing chamber 14. Referring also to FIG. 1, the plate 114 contains an annular pattern of holes 116 therein which are aligned with an annular gas outlet channel 118. This channel is connected via outlet bore 121 to a conventional vacuum pumping system (not shown), which establishes the vacuum within the chamber and exhausts the spent gases and entrained gas products from the chamber.

As mentioned (see FIG. 10), the upper purge gas flow is through inlet 98 (arrow 93), channels 100, 102 and 106 (arrow 95), then out purge ring apertures 108—108 (arrow

93) at the outer upper edge of the process-positioned wafer 15. Simultaneously (see FIG. 2), the lower purge gas flow is through inlet 110 (arrow 101) and annular ring 112 across the quartz window 70, sweeping the window clean (arrow 103), then upwardly toward the lower peripheral bottom edge of the wafer 15 (arrow 105). Referring to FIG. 10, the upper and lower gas purge flows 97 and 105 merge at the wafer's edge and flow outwardly as indicated by arrow 107 across the plate 114 and through the holes 116 therein into the annular exhaust channel 118 and out of the chamber along path 109 (FIG. 2). This upper and lower, merging flow pattern not only keeps the quartz window 70 clean, but also sweeps spent deposition gases, entrained particulates, etc., out of the chamber 13. The combination of the dual, upper and lower purge flows which are conformed to the inner quartz window chamber surfaces and to the circumferential wafer edge and the very high chamber pressures (unusually high for PECVD) provide a very effective purge and prevent deposition external to the wafer.

Equally important, uniform radial gas flow is provided across the wafer 15 by the multiplicity of holes 116—116, illustratively five in number, which are formed in the distributor plate 114 peripherally around the wafer 15. These holes 116 communicate into the larger semi-circular exhaust channel 118 which, in turn, is connected to the vacuum exhaust pumping system via the single outlet connection 121. The channel 118 has large conductance relative to the holes 116—116 because of its relatively very large volume, which provides uniform pumping at all points radially from the wafer, with the simplicity of a single point pump connection. In combination with the uniform gas flow distribution inlet pattern provided by manifold 26, this uniform radial pumping provides uniform gas flow across the wafer 15 at all pressures and, thus, uniform deposition even at very high chamber pressures such as 200 torr and above. Also, the manifold 26 is usable as an electrode for a uniform glow discharge plasma at unusually high pressures, which enables both the very high deposition rate and the effective purge flow.

E. Anti-Electrical Breakdown Gas Feed-Through 36

As mentioned, the advantages of using the gas box 26 as the powered RF electrode include the wafer residing on the grounded counter electrode, which makes possible a high degree of plasma confinement that would not be achievable if the RF energy was applied to the wafer and the gas box was grounded. Additionally, the hardware is mechanically and electrically simpler since electrical isolation between wafer/susceptor and chamber is not required (or permitted). Temperature measurement and control of the susceptor/wafer in the presence of high frequency electric and magnetic fields is greatly simplified with the susceptor grounded.

However, applying high power, high frequency, large potential RF energy to a conventional gas distribution system and, in particular, across a short distance between metallic gas tubing and gas manifold normally would cause premature electrical breakdown of the process gas within the distribution system upstream of the plasma processing chamber. In other words, in conventional systems the RF voltage would create a plasma within the distribution system, which would cause unwanted deposition of the process gas on the internal surfaces of the gas distribution system.

Our combination RF/gas feed-through 36 (FIG. 12) is designed to apply RF power to the gas box 26, that is, to use the gas box as the powered RF electrode, without breakdown of the process gas and without deposition within the gas distribution system.

Also, consistent with one of the overall objectives of achieving a small, compact CVD reactor, the RF/gas feed-through 36 is of a compact, low profile design, despite our design objective that the high RF potential be applied parallel to the gas flow path to yield a constant voltage gradient over a distance to eliminate the high local electric field which causes electrical breakdown.

It should be mentioned that prior gas feed-throughs are incapable of achieving the above objectives. Two such prior art approaches are known to us. The first approach flows the gas within an insulating tube between surfaces that are at a high electric potential difference. A second approach flows the process gas through an insulator between the surfaces of high electric potential difference at sufficiently high gas pressure so that electrical breakdown does not occur. The first approach is not compact and does not work at high frequencies, where electrical breakdown is more efficient (see, e.g., curve 201 and 200, FIG. 14). Also, this first approach is not capable of operation where there is a small p.d (pressure.distance) product. The second approach is more compact than the first, and less susceptible to electrical breakdown at high frequencies, but is also subject to electrical breakdown where there is a small pressure.distance product.

Referring now to FIG. 2 and, primarily, to FIG. 12, the feed-through 36 comprises an inlet end connector or manifold 120, an outlet end connector or manifold 122 and an intermediate gas feed structure 124 comprising a quartz tube 126 and an elongated insulating transition housing 128. The block 128 is mounted to and between the end connectors 120 and 122 using O-ring seals 130—130 to provide vacuum-tight mounting. The internal bore 127 of the quartz tube 126 communicates with gas inlet bore 134 in the inlet end connector and gas outlet bore 136 in the outlet end connector.

Process gases and purge gas under pressure from sources such as an ozone generator, a liquid-TEOS vaporizer, and conventional pressurized gas tanks or bottles are routed through conventional valves or an automatic flow control system for controlled flow rate application to the inlet manifold 120.

As indicated by arrows 131—135, process gas is routed through the feed-through device 36 via the inlet bore 134 and through the quartz tube 126 and out the outlet bore 136 and into the mating inlet bore 88 in the gas distribution head 32. Please note, the feed-through is shown enlarged in FIG. 12 to facilitate illustration. The actual feed-through 36 is of a size so that the gas outlets 136 and 146 are aligned with the mating channels or bores 88 and 98 in the reactor cover 80.

The purge gases are routed through the feed-through cordially with the process gas flow path so that if there is a leak along the process gas path 131—133—135, the process gas is harmlessly transported into the process chamber 14 along with the purge gas and, thus, does not escape into the ambient.

The incoming purge gas is applied to inlet bore 138 in the inlet end connector 120. Bore 138 communicates with an annular channel 139 formed in the spool-shaped fitting 140 which is mounted near the inlet end of the quartz tube 126. This spool fitting 140 is sealed at the outer end thereof by cylindrical flange fitting 142 and O-ring seal 144. The annular channel 139 communicates via holes (not shown) with the annular passage 147 between the tube 126 and concentric block 128. The passageway 147 feeds similarly into annular chamber 139 in fitting 140 at the outlet end of the tube 126. The tube 126 is mounted and sealed at the

outlet in the same way described above relative to its inlet end. At the outlet end, chamber **139** feeds into the outlet bore **136**. This arrangement provides an isolated purge gas flow path through the feed-through **36**, as indicated by arrows **148–156**.

The co-axial gas feed apparatus described above provides a dual barrier which prevents the leakage of potentially toxic process gases into the atmosphere. That is, the path to the ambient between mating surfaces is barred by the two sets of O-ring seals **130** and **144**. These seals are positioned in series along the potential path to the ambient. Also, as mentioned, in the event of internal system leaks such as a leak in the quartz tube **126**, the purge gas flow carries the process gas into the process chamber **14**, where both are exhausted by the chamber vacuum system. In addition, the process and purge gases are routed entirely through the chamber components, i.e., through substantial blocks/bodies such as the aluminum connectors **120** and **122** and the insulator block **128**. Consequently, external, typically flexible, gas tubing is eliminated at the reactor. The very solid, secure routing fixtures, the dual seal barriers, and the co-axial gas flow in which the purge gas flow surrounds the process gas flow, provide a safe, secure process gas flow path in the reactor and feed-through device.

As shown in FIG. **12**, the inlet end connector **120** is connected to ground. The outlet end connector **122** is connected to the RF power supply **128** and connects the RF energy to the cover **80** and manifold plate **92**. A constant electric potential gradient is provided along the column of process gas flow between the grounded connector **120** and the driven connector **122** by providing one of three types of constant voltage gradient elements along the surface of the quartz insulating tube **26**; a radio frequency coil which provides resistive, inductive, or capacitive (effective) impedance; a resistive film; or a resistive sleeve.

As shown schematically in FIG. **13A**, the RF coil **160** is a wire coil that is wound around the quartz gas tube **26** between the ends thereof and the high voltage which is applied across the tube length. Preferably, the wire coil **160** is of No. 24 to No. 26 AWG aluminum wire. The desired electrical impedance at the frequency of operation is obtained by selecting the wire material, diameter, number of turns per unit length, length and the winding technique. This A.C. impedance can be selected to have a net inductive/resistive impedance or a net capacitive/resistive impedance or to be purely resistive (resonant). The A.C. and D.C. resistance can be selected (using wire diameter, length, and material). A typical application has a high inductive reactance but is a D.C short. For a radio frequency driven system of 13.56 MHz, typical values for the inductance of an RF coil-type feed-through are approximately 10–15 microHenries. For the resistive film or sleeve feed-through, a resistance of 100 to 500 Kohms is typical.

Alternatively, as shown in FIG. **13B**, a resistive film **162** of material of controlled electrical resistivity and thickness, such as Acheson "Aerodag G" (a colloidal suspension of micron size graphite particles in an isopropyl alcohol dispersing medium), is coated on the outside of the quartz tube **126** to provide the desired resistive impedance and allow broad band (frequency) operation.

The third alternative shown in FIG. **13C** uses a solid resistive sleeve **164** of a material such as a composite ceramic of controlled electrical resistivity, to provide the desired electrical resistive impedance and broad band frequency operation.

Still another alternative, a variant of the solid resistive sleeve **164**, uses a sleeve of material which is ferromagnetic

with very high permeability at the frequency of interest, and has controlled electrical resistivity. Operation is the same as for the resistive sleeve **164**, with this added advantage. Should breakdown occur under severe conditions, the presence of magnetic material and initially high current and resulting high magnetic field produces a very large inductive reactance to charge flux (current), which very quickly reduces then extinguishes electrical conduction in the process gas.

FIG. **14** illustrates representative bench test data for a quartz tube without a constant voltage gradient device of voltage breakdown in kilovolts as a function of pressure in torr at both low (100 kHz) and high (13.56 MHz) radio frequencies. As indicated, for the pressure range of 5–20 torr, the breakdown range was 3 to 7 kV for the low radio frequency and approximately 2 to 5 kV for the high radio frequency.

FIG. **15** illustrates bench test data of breakdown voltage as a function of pressure for Tube A, a tube of length 10.5 cm and diameter 0.6 cm without a constant voltage gradient device, and Tube B, the same tube with a constant voltage gradient device of the wire coil type, **160**, consisting of 160 turns of ± 26 AWG wire. Tube C was the same as tube B, except for having a greater length, 13.4 cm. This illustrates that the RF/gas feed-through **36** is very effective in preventing breakdown and subsequent deposition of process gases under actual reactor operating conditions. In fact, typically the reactor system **10** will be used at pressures of up to 200 torr and above, at which values the breakdown voltages will be much higher than those depicted in FIG. **14**.

In short, the anti-electrical breakdown gas feed-through **36** of the present invention provides a constant voltage gradient along the process gas flow column, without charge build-up. In addition, the feed-through **36** is designed to incorporate resistive, inductive or capacitive electrical impedance between the high potential difference ground and driven surfaces. The choice of impedance depends upon the electrical requirements of the system, i.e., low frequency, high frequency, wide band, d.c. operation, etc. This constant electrical potential gradient effectively prevents premature breakdown and deposition within the gas distribution system **32** and feed-through **36** at high or low radio frequencies. In addition, the structure of the feed-through **36** including the co-axial gas feed (the purge gas flow outside the quartz tube and the process gas flow inside the quartz tube) is highly resistant to process gas leaks and purges any process gas leaks into the system exhaust.

Finally, it should be mentioned that temperature controlled water can be flowed through channels (not shown) in the feed-through device **36** isolated from process and purge channels to (heat or cool) control the temperature of the gas in the feed-through. In a typical application which uses gases such as ozone or TEOS, it is important that the gas temperature be controlled so that, for example, condensation (feed-through too cold), decomposition (too hot), or chemical reaction (too hot) do not occur within the tube. Any of the above occurring inside the gas feed-through device could severely affect the desired process. Additionally, if the gases reacted inside the quartz tube, deposition could occur inside the tube.

F. Summary of Certain Key Features

1. Uniform Wafer Heating

Our reactor uses a tailored non-uniform near-IR radiant heating pattern and a thin, low mass high emissivity susceptor to provide thermal efficiency, fast thermal response (heating and cooling), excellent temperature uniformity

despite the inherent non-uniform heat losses of thin circular wafers, and good transmission through a chamber window of quartz or the like (which permits external mounting of the radiant heating module).

2. Gas Distribution System

The RF powered gas manifold **26** provides the necessary high power to enable confinement of the plasma. Also, the uniform gas inlet flow pattern provided by the gas manifold and radial exhaust pumping provide uniform gas inlet and exhaust (purge) pumping and uniform radially gas flow across the wafer, enabling uniform processing (deposition/etching) over a wide pressure regime including very high pressures. The radial pumping and high pressure capability provide confinement of the plasma/reactant species to the wafer and; in enabling effective purging, prevent deposition within the chamber except on the wafer. The precisely temperature-controlled internal and external surfaces of the gas manifold prevent decomposition, reactions, condensation, etc., within the gas box and eliminate undesirable particulate-generating deposits on the external gas box surfaces. For example, temperature controlled water is circulated within the gas box to maintain the temperature between about 35° C.-75° C. to prevent internal deposition or condensation of TEOS below about 35° C. and to prevent internal decomposition of or reaction between ozone and TEOS above about 70° C., and to maintain the external face of the gas manifold greater than about 100° C. to prevent flaky external deposits.

3. Gas Feed-Through

The gas feed-through provides the enables the application of high voltage RF power to the gas box, as well as the application of purge gas and process gas to the gas box, without gas breakdown.

4. Wafer Transport System

A one-axis robot susceptor/wafer support and transport system is adapted to load and unload wafers at a selected position within the chamber onto and from an external robot blade. This transport system provides variable parallel close-spacing between the susceptor/wafer and the overlying gas manifold and provides variable spacing by simply selecting the vertical travel of the associated susceptor support fingers and susceptor elevator mechanism. The parallelism increases plasma stability and uniformity by eliminating the tendency to run to one side or the other and, thus, enables uniform processing (deposition and etching). The variable close spacing of the distance, *d*, between the outer face of the gas manifold and the wafer surface facilitate the implementation of different types of process. Also, the spacing can be set at a very small variable dimension such as, for example, one centimeter, 0.5 centimeter and even smaller, to enable confinement of the plasma and/or gaseous reactants between the gas distributor and the wafer. This confinement increases the reaction efficiency and increases the rate of the reaction (deposition or etching) and helps prevent deposition everywhere except on the wafer, and even at very high chamber pressures.

5. Wide Pressure Range, High Pressure Regime

High pressure capability results from a number of the above-summarized factors including uniform radial pumping, the uniform gas flow provided by the gas manifold, the confinement provided by the variable close spacing between the electrodes and the application of high power density RF power to the gas manifold.

G. Relevance of Features to Multiple Process Capability

The above key features can be summarized as follows: (a) Wide pressure, high pressure regime; (b) Temperature uni-

formity of susceptor wafer; (c) Uniform flow distribution; (d) Variable close spacing of electrodes (inlet gas manifold and susceptor) with parallelism; and (e) Temperature control of internal/external gas inlet manifold surfaces.

Typically, at least several of these features are very important to each type of processing for which our reactor has been used. These key features are summarized below on a process-by-process basis.

1. Thermal Chemical Vapor Deposition

(a) Wide pressure, high pressure regime.

(b) Temperature uniformity of susceptor/wafer.

(c) Uniform flow distribution.

(d) Variable close spacing of electrodes.

(e) Temperature control of internal/external gas inlet manifold surfaces, especially where unstable gases such as TEOS and ozone are used.

2. Plasma-Enhanced CVD

(a) Wide pressure, high pressure regime.

(c) Uniform flow distribution.

(d) Variable close spacing of electrodes with parallelism.

(e) Temperature control of internal/external gas inlet manifold surfaces.

Temperature control of the gas box external surface to 100° C. is important to prevent the deposition of porous particulate causing films.

High pressure operation increases ion scattering, which decreases bombardment of and damage to the wafer and enhances step coverage. This, because high pressure operation dilutes the concentration of the gas molecules to the point where they do not react at a sufficient rate to cause particles/unwanted deposition on surfaces. The high pressure capability and associated decreased bombardment enables one to decrease the bombardment level for a given power/voltage and reaction rate or, alternatively, to use higher power/voltage to obtain a higher reaction rate for a given bombardment level. Uniform flow distribution is also critical, particularly at the close spacing of less than one centimeter used in our reactor, because it confines the plasma and thus enhances clean operation. The ability to adjust the electrode spacing with parallelism permits the use of the close spacing with the plasma stability necessary for deposition.

3. Plasma-Assisted Etchback

(a) Wide pressure, high pressure regime.

(d) Variable close spacing of electrodes.

The variable large spacing in combination with the high pressure capability permits effective etchback. The variable spacing between electrodes is very important because it would be impossible to optimize the etch and other processes without varying the electrode spacing used for deposition. For example, a typical spacing of <1 cm is used for thermal CVD and PECVD while the etchback requires a spacing of ≈0.4 in or 1 cm.

4. Reactor Self Clean

(a) Wide pressure regime.

(b) Variable close spacing of electrodes (inlet gas manifold and susceptor) with parallelism.

The variable spacing in combination with variable pressure permits effective reactor self-cleaning. Here, the required spacing, *d*, ≈0.4 in. or 1 cm. is larger than that required for, e.g., thermal CVD and PECVD. The relatively larger spacing and wide pressure regime permits the plasma to diffuse within the reactor (rather than being confined as required for the deposition processes) and clean the entire

reactor. A typical self-cleaning sequence uses RF power of 500 watts, gas NF_3 or other fluorine containing chemistry at flow rates typically of 0.1 slm, pressure of 0.5 torr, and $d=0.4$ in., and has provided ebb rates of ≈ 0.5 micron/sum.

5. Sputtering Topography Modification

(a) Wide pressure, high pressure regime.

Variable close spacing of electrodes (inlet gas manifold and susceptor) with parallelism.

Here, the high pressure capability combined with 0.2 in. spacing as well as the ability to apply RF power to the gas box at high power levels permits sputtering of materials such as oxide or other dielectrics using gas chemistry such as argon or other heavy molecule gas chemistry such as SiCl_4 . A typical sputtering process involves application of RF power of 700 watts, gas flow rates 0.1 slm, pressure of 10 mt. electrode spacing, d , of 0.2 in. to 0.5 in.

II. Multiple Step In-Situ Planarization Process and Steps

The processing steps and multiple step processing sequences described here were performed in the reactor **10**. The ability to perform multiple step processing using temperature sensitive gases such as ozone and TEOS and different steps such as CVD, PECVD, etching, and self-cleaning in-situ qualifies the reactor **10** as being uniquely preferred. However, the process disclosure here will permit those of usual skill in the art to practice the process sequences albeit in single process, dedicated reactors and to adapt such reactors, e.g., to the use of the process.

A. Low Temperature Thermal CVD of Conformal SiO_2

The thermal chemical vapor deposition of highly conformal silicon dioxide is an improvement of methods which use the pyrolysis of TEOS and oxygen. The present thermal CVD invention is based in part upon the discovery that improved highly conformal ($\sim 100\%$) silicon dioxide coatings are formed by the thermal chemical vapor deposition of the reactants TEOS and ozone at relatively low temperatures, using lamp radiant heating to provide a wafer temperature of about 200°C. – 500°C. , and high pressures. The ozone lowers the activation energy of the reaction kinetics and forms silicon dioxide with the TEOS at the relatively low temperatures of about 200°C. to 500°C. A commercially available high pressure, corona discharge ozone generator is used to supply a mixture of (4–8) weight percent ozone in oxygen to the gas distributor. Helium carrier gas is bubbled through liquid TEOS to vaporize the TEOS and supply the diluted gaseous TEOS in the He carrier to the gas distributor.

In particular, the thermal chemical vapor deposition process uses the reactants ozone (O_3), oxygen and tetraethylorthosilicate (TEOS) at a low temperature within the range of about 200°C. – 500°C. and at a high pressure within the range of about 10–200 torr and, preferably about 40–120 torr, to deposit a highly conformal silicon dioxide coating that fills in the voids, cusps and other topographical irregularities and thereby provide a substantially planar surface. In the presently preferred embodiment, the ozone is applied at a flow rate of 2 to 3 slm, the helium carrier gas flow rate is 50 sccm to 1.5 slm, the chamber pressure is 40 to 120 torr and the wafer temperature is $375^\circ\text{C.}\pm 20^\circ\text{C.}$, thereby providing a highly conformal undoped silicon dioxide coating at a deposition rate of 3,000 Angstroms/min.

As mentioned, the gas distribution manifold (gas distributor **26**) of the reactor **10** is controlled by de-ionized water of temperature 20°C. – 50°C. circulating in passages therein to maintain the internal surface of the gas distributor **26** within

the narrow range of about 35°C. – 75°C. , i.e., at a temperature of less than about 75°C. to prevent decomposition of the TEOS and reaction between the TEOS and ozone and above 35°C. to prevent condensation of the TEOS inside the gas distributor.

The distance, d , from the temperature-controlled gas distributor to the surface of the substrate is preferably approximately one centimeter or less. This distance of one centimeter or less confines the plasma or gaseous reactants between the gas distribution **26** and the wafer **15**. This increases the reaction efficiency, and increases the rate of the reaction (deposition) and helps to prevent deposition everywhere except on the wafer.

The thermal CVD process of the present invention uses unusually high deposition chamber pressures: pressures of preferably at least ≥ 10 torr and of about 20–200 torr are utilized. Even the lower portion of this range is over 20 times greater than the total pressure normally utilized in processes utilizing TEOS. The high pressure increases the density of available reactive species and, thus, provides a high deposition rate.

Furthermore, the use of high pressure enables an effective purge. The high purge flow rate improves the ability to remove waste gases, entrained particulates, etc., without unwanted deposition on the chamber surfaces. The above-described bottom purge flow sweeps radially outwardly across the bottom side of the susceptor wafer. The bottom flow is joined by an upper purge flow that is directed downwardly at the wafer's periphery. The combined streams flow radially outwardly from the periphery of the wafer, and cause the deposition gas to flow radially uniformly outwardly, then through the exhaust system of the chamber at very high flow rates. For example, useful top purge gas flow rate (preferably nitrogen) may be from 1 slm to 10 slm and the bottom purge gas flow rate (again, nitrogen) may be 1 slm to 20 slm. These high pressure, high flow rate top and bottom flows purge unwanted gases and particulates everywhere without disrupting the uniform deposition gas distribution at the top of the wafer.

Using the reactor **10**, the presently contemplated useful flow rate range of the helium gas (the carrier for TEOS) is 100 sccm to 5 slm (sccm=standard cubic centimeter per minute; slm=standard liters per minute) and the associated ozone, O_3 , flow is provided by the composition of 4 to 8 weight percent ozone in oxygen flowing at a rate of about 100 sccm to 10 slm. The total gas flow rate, not including the purge gases, typically can be within the range 200 sccm to 15 slm.

The above-described gas flow, chamber pressure, and resulting chamber temperature have provided a silicon dioxide deposition rate of about 500 Angstroms/min. to 4,000 Angstroms/min.

While useful deposition rates of 500 and 400 Angstroms/min. have been achieved at corresponding temperatures of 200°C. and 500°C. , as shown in FIG. **20** the deposition rate peaks at about $375^\circ\text{C.}\pm 20^\circ\text{C.}$ The decreased deposition above and below the peak is a consequence of unfavorable reaction kinetics at the surface of the substrate. Fortunately, the peak temperature is also close to the maximum processing temperature of about 400°C. for aluminum-containing multiple conductor structures. Above $\sim 400^\circ\text{C.}$, hillocks form in aluminum. Above $\sim 500^\circ\text{C.}$, aluminum softens.

Referring to FIG. **21**, using an (ozone and oxygen):helium flow rate ratio of 2:1 (2 slm of 8 wt. percent ozone in oxygen: 1 slm He carrier and TEOS) the deposition rate saturates at 3,000 Angstroms/min. at a chamber pressure of

80 torr, and wafer surface temperature of 375° C. (using a TEOS temperature of 35° C.), with very little increase at higher pressures. Decreasing the temperature to 200° C.–375° C. at 80 torr decreases the deposition rate to 1,000–3,000 Angstroms/min., respectively. At 20 torr, temperatures of 200° C.–375° C. provide a deposition rate of 500–1000 Angstroms/min. Above pressures of about 120 torr, gas phase reactions increase particulates. This can be controlled by decreasing the wafer temperature or increasing the diluent flow rate, but these steps decrease the deposition rate.

While the resulting films have been characterized as having improved physical and electrical properties such as cracking resistance, density, refractive index, shrinkage, rate of etching, breakdown voltage, flat band voltage, mobile ion contamination, pin hole density and silicon oxide purities, the crucial aspect is the excellent ~100% conformal coverage over vertical and horizontal surfaces of steps and over other surface irregularities. Consequently, problems such as overhang, cusps and voids are much less severe, thereby minimizing or even eliminating the amount of follow-up processing which must be done to remedy such problems and to achieve planarization.

Furthermore, this high conformality coverage is provided using undoped oxide coatings. Conventional processes use reflowing to smooth the deposited oxide and incorporate phosphorus or boron doping (phosphosilicate glass, PSG, borosilicate glass, BSG, and borophosphosilicate glass, BPSG) to lower the reflow temperature. Our thermal CVD process eliminates the need for reflowing and, thus, the use of PSG, BSG and BPSG and associated problems such as aluminum corrosion. However, if desired, in our thermal CVD process, the conformal oxide could be doped to a low level of, e.g., 1 weight percent to 10 weight percent of phosphorus and/or boron by incorporating reactants such as TMP (tetramethylphosphite) and/or TMB (tetramethylborate). The low concentration doping level would provide sufficient reflow characteristics.

B. Two-Step Planarization Process

In one aspect, the process of the present invention is an improvement of conventional methods for planarizing silicon dioxides such as, for example, conventional methods using spin-on glass and polyimide deposition with etch-back

Another aspect of the present invention is the use of the above-described thermal CVD silicon dioxide deposition process to substantially planarize a dielectric layer, followed by the use of an isotropic wet or dry etch, preferably at a high etch rate, to complete the planarization process. The combination of the above-described low temperature, thermal CVD, conformal oxide deposition process in conjunction with various wet or dry isotropic etch steps provides an unexpectedly conformal, planarized dielectric layer which serves well in the small geometry, multi-level metallization structures that are currently being developed and will be developed in the future. Described below is a presently preferred dry isotropic etch process which can be performed in-situ, in the same, referenced multi-step chamber.

C. Three-Step Planarization Process

In another aspect the present invention is embodied in a three-step process which, first, forms a layer of silicon dioxide, preferably at a high deposition rate; the above-described ozone and TEOS-based thermal CVD conformal oxide deposition process is used as the second step to form a highly conformal oxide coating; then, in the third step, a preferably high rate isotropic etch is applied to quickly complete the planarization process.

D. Preferred Three-Step Planarization Process

In another aspect of the present invention, the above-described thermal CVD, conformal oxide deposition process is used in a three-step high deposition rate, high throughput planarization process in-situ in the referenced multiple process CVD/PECVD deposition chamber. The planarization process can be applied over existing dielectric layers or can be used alone to form a planar dielectric.

The preferred first step is a PECVD oxide deposition. The PECVD oxide deposition process uses a plasma formed from TEOS, oxygen, and a carrier gas with or without a diluent such as helium. This process uses a deposition chamber pressure of from about 1 torr to about 50 torr; an oxygen flow rate of from about 100 sccm to 1,000 sccm, an inert carrier gas (helium) flow rate of from 100 to 1,500 sccm, a total gas flow rate (not including the purge gases) of 200 sccm to 2.5 liters per minute, and RF power to the ~6 in. diameter gas distributor cathode of about 200–400 watts. Power density at the gas distributor/cathode is about 1 watt/cm² based on calculations for a quasi-parallel late configuration. Radiant energy is directed to the susceptor from below by the annular array of vertical lamps to generate a deposition plasma and heat the wafer surface to a temperature of 300° C. to 500° C. Top (nitrogen plus helium mixture) and bottom (nitrogen only) purge gas flow rates of 1 to 15 slm and 1 to 20 slm, respectively, are used with respective preferred top and bottom purge gas flow rates of 2.5 slm and 10 slm. These parameters provide SiO₂ deposition rates of about 5,000 Angstroms/min. to 10,000 Angstroms/min. Typically, 0.4 cm ≤ d ≤ 1 cm.

Presently preferred operating parameters for the PECVD oxide deposition step for a 6 in. wafer are 600 sccm oxygen, 900 sccm helium, 16,000 sccm total flow (including purge; 1,500 sccm excluding the purge), 10±2 torr pressure and 375° C.±20° C. wafer temperature. The parameters provide SiO₂ deposition rates of about 8,500 Angstroms/min. for a gas distributor-to-wafer surface distance, d=0.4 cm.

Quite obviously, the above-described high pressure, PECVD oxide deposition process, which is based upon TEOS gas chemistry and has essentially the same chamber requirements as the crucial conformal silicon dioxide deposition step, makes the use of the same chamber not only possible, but preferable.

There are several methods known in the art for depositing silicon dioxide by chemical vapor deposition, including the use of silane and oxygen and pyrolysis of tetraethylorthosilicate (TEOS) at a temperature in the range of 700 to 800° C. at a pressure less than about 5 Torr. This pyrolysis process may be utilized, with a silicon nitride, silane and ammonia plasma, or with oxynitride, silane, ammonia and N₂O plasma. Plasma-assisted chemical vapor depositions using TEOS at pressures below 1 Torr are also utilized, with variations including use of spin on glass, and polyimides.

The present PECVD process provides methods for improving deposition rate, cracking resistance, physical and electrical properties of CVD-deposited silicon dioxide. The present invention also provides an improved method for depositing silicon dioxide whereby improved step coverage and lower stress of the deposited layer are obtained.

In particular, the present PECVD process provides an improved method for the plasma-enhanced chemical vapor deposition of TEOS to obtain the above advantageous improvements whereby the preferred conditions of deposition are a higher than usual pressures (up to 50 Torr) and at temperatures of about 200° C. to 400° C. The usual conditions for the plasma-enhanced chemical vapor deposition

using TEOS are at a total pressure range of up to about 1 Torr (including the carrier gas), of which the oxygen in the plasma is at a pressure of about 0.4 Torr. During deposition, the substrate temperature usually gradually increases from about room temperature to about 400° C. See, for example, Mackens et al. *Thin Solid Films*, 97:53–61 (1982).

The deposited silicon dioxide coatings according to the present invention also have improved cracking resistance and have improved step coverage over silicon dioxide coatings deposited by other methods. The problem of step coverage deals with the creation of a mushroom-shaped deposited overhang at the corners of the step substrate. This overhang must be removed by subsequent processing, thus complicating the process. By utilizing the process according to the present invention, the problem of the overhang is much less severe thereby minimizing or even eliminating the amount of processing to remedy this problem.

The silicon dioxide coatings formed according to the present invention also exhibit lower stress and are characterized generally by indices of $-IE9$ (compression) to $+IE9$ (tension), with the preferred index being $-IE8$. Also, the coatings according to the present invention exhibit improved physical and electrical properties and that the density, refractive index, shrinkage parameters, rate of etching, breakdown voltages, flat band voltages, mobile ion contamination, pinhole densities and silicon oxide purity are improved.

Finally, by utilizing the process according to the present invention, particularly in the apparatus disclosed in the above-identified co-pending application, the operation at high pressures (presently up to about 50 Torr) allows the plasma to be confined at the top of the substrate, thus making it less likely to contaminate the sides of the chamber and the surfaces on which deposits are not desired.

Preferably, the third step is a high rate isotropic etch process comprising the step of exposing the existing silicon dioxide surface to a plasma formed from fluorinate gas selected from CF_4 , NF_3 and C_2F_6 in a doping gas such as helium to stabilize the plasma, in a chamber at a temperature in the range of about 100° C. to 500° C. and preferably 200° C. to 400° C. (Helium and/or oxygen can be incorporated to form gases with the carbon.) The total gas chamber pressure for these gases will usefully be in the range of about 200 mt to 20 torr. The preferred range is 500 mt to 10 torr. The total gas flow rate of the plasma will be determinable by those skilled in the art. However, an operable range of 20 sccm to 3.5 slm has been found useful for the apparatus disclosed in the referenced multiple process CVD/PECVD reactor. The preferred total gas flow rate is from about 170 sccm to 1.25 slm. The useful range for the NF_3 (or C_2F_6) gas flow is from about 10 sccm to 500 sccm, with the preferred range being from about 70 to 200 sccm. The individual flow rate of the doping gas, usually helium, will be from about 10 sccm to 3.5 slm and, preferably, 100 sccm to 1 slm. RF power density of about 0.5–1 watts/cm² was used, along with radiant power from the lamp module to provide the substrate temperature of <500° C. and the preferred temperature of 200° C.–400° C. A distance $d \geq 0.4$ cm is used. Below 0.4 cm, plasma instability increases. Also, as d is increased above 1 cm, the etch may become too effective and etch other components.

At the relatively high temperatures used, it has been found that rapid accurate isotropic etching of the silicon dioxide is accomplished. Specifically, etching rates of from 500 Angstroms per minute to 1 micron per minute are obtained wherein the etching is isotropically performed and smooth.

While this isotropic etch process is also useful generally, for example, for forming metal contacts, it is particularly

useful for providing profile control of SiO_2 step-coverage layers, as described above. In particular, this uniform high rate isotropic etch has the advantage of additionally planarizing the substantially planarized contour which results from the SiO_2 deposition.

This high rate isotropic etch step was done in-situ in the same reactor used for the two above-described silicon dioxide deposition steps. As a consequence, this preferred sequence provides an integrated in-situ three-step process for forming a planarized silicon dioxide layer even over non-planar layers incorporating small geometry steps, trenches, etc. In combination with the TEOS and ozone-based thermal CVD conformal oxide deposition step, the use of the high rate PECVD oxide deposition step and the high rate etching step, the ability to use the same chamber for all three steps provide a fast, high throughput planarization process which is also less susceptible to contamination and wafer damage and other problems which result when a wafer is handled repeatedly and switched from one chamber to another.

The use of the above-described three-step planarization process is shown schematically in FIGS. 18 and 19. As depicted in FIG. 18, the first step forms a relatively thick stepped layer 182 of silicon dioxide over the stepped topography 181 at a very high deposition rate. The second step is then used to form thereon conformal silicon dioxide layer 183, which is substantially planarized despite the underlying deep step 184. Finally, as shown in FIG. 19, the third, isotropic etch step quickly etches away the upper surface 185 to below the residual step topography 186, if any, in layer 183, thereby providing a smooth planar surface 187 for subsequent layers.

In addition, while the above-described three-step in-situ process is a presently preferred embodiment of our planarization process for silicon dioxide, the ozone- and TEOS-based thermal CVD step (second step) can be used in combination with other initial dielectric coatings and other isotropic etch steps. For example, the ozone thermal CVD second step can be used to deposit a highly conformal silicon dioxide coating on silicon oxide or silicon nitride or silicon oxynitride or other dielectric layers formed by CVD or by other methods, and the resulting substantially planarized layer can be etched to a planar topography using other, preferably high rate, dry (e.g., plasma) or wet chemical isotropic etch methods.

E. Chamber Self-Cleaning

An isotropic chamber self-cleaning etch sequence has been done using fluorinated gas at a pressure of about 600 mT to 10 torr, high RF power density of 1–2 watts/cm², distance, d , ≈ 1 cm and the other parameters, including the gas flow rates, described above for the isotropic etch process. This process has been used to clean the referenced multi-step CVD/PECVD reactor. After depositing an $\sim 5\mu$ thick silicon dioxide film on a wafer, the chamber can be cleaned in about one minute.

F. Summary; Alternative Process Sequences

The following is a partial listing of some of the possible ways in which the above-described deposition, etch and self-cleaning steps can be used, alone and in combination.

First, the thermal CVD conformal-oxide deposition process using ozone, oxygen and TEOS can be used alone to planarize an existing dielectric which has been formed, for example, without perfect step coverage or with perfect step coverage on a non-perfect topography.

Secondly, the conformal oxide-forming thermal CVD step can be applied to existing dielectrics followed by an isotro-

pic etch step to etch back any remaining non-planarities to a planar topography.

Third, in a preferred high rate planar-dielectric forming sequence which can be used by itself to form dielectrics such as inter-level dielectrics or can be applied to rectify imperfect step coverage and/or topography in existing dielectrics, the above-described high rate PECVD oxide step is applied followed by the conformal oxide-forming thermal CVD sequence. In a preferred sequence using isotropic etch back to remove any non-planar features, the high rate PECVD oxide deposition sequence is utilized followed by the conformal oxide-forming thermal CVD step followed by an isotropic etch step, preferably the above-described high rate plasma isotropic etch.

Numerous other combinations are possible for particular situations/problems. For example, the following sequence may be preferred where it is desired to form a thin protective oxide layer over a sensitive device or other structure before the application of RF power:

1. Thermal O₃ CVD Conformal-Oxide Deposition;
2. High Rate PECVD Oxide Deposition;
3. Thermal O₃ CVD Conformal-Oxide Deposition;
4. PECVD Oxide Deposition; and
5. High Rate Isotropic Etch.

Also, for forming very thick planar oxides over stepped topographies, the first two steps of the following sequence can be used to planarize the stepped topography followed by application of the high rate oxide deposition to build up the very thick oxide thickness over the planar surface:

1. High Rate PECVD Oxide Deposition;
2. Thermal O₃ CVD Conformal Oxide Deposition; and
3. High Rate PECVD Oxide Deposition.

As another alternative, the very thick planar oxide process described immediately above can incorporate an isotropic etch back as the final step to achieve full planarization, and the required thickness.

Finally, but certainly not exhaustively, the isotropic chamber self-cleaning etch can be inserted as desired within or at the end of the other process sequences to maintain the chamber in a clean deposition-free state.

While this invention has been described above in connection with various preferred and alternative embodiments, it is understood that persons of skill in the art can make numerous modifications without departing from the scope of the invention as claimed in the following claims.

What is claimed is:

1. In a process for depositing silicon dioxide onto a substrate by exposing the substrate to plasma formed from a gas mixture which includes tetraethylorthosilicate, the steps of: positioning the substrate on a support within a vacuum chamber and adjacent a gas manifold which is an RF electrode and includes a multiplicity of closely-spaced gas outlet holes closely adjacent the substrate; and communicating the gas mixture into the manifold while applying RF energy between the manifold and the substrate support and maintaining the total pressure in the chamber within the range of about 1 to 50 torr and the temperature of the substrate in the range of about 200° [C.] C to 500° [C.] C so that a layer of silicon oxide is deposited onto the substrate at a deposition rate greater than 400 angstroms per minute, said silicon oxide layer quality and step coverage being adequate for VLSI semiconductor fabrication.

2. The process of claim 1, wherein the chamber pressure is about 1 to 12 torr.

3. The process of claim 1, wherein the gas mixture includes oxygen.

4. The process of claim 1, wherein the chamber pressure is about 1 to 12 torr and the gas mixture includes oxygen.

5. The process of claim 1, wherein the distance between the gas outlet holes and the substrate is less than about one centimeter.

6. The process of claim 1, 2, 3, 4, or 5, further comprising communicating a purging gas into the vacuum chamber from the periphery of the manifold in a flow radially away from the substrate to confine the deposition plasma species to the substrate.

7. The process of claim 1, 2, 3, 4 or 5, further comprising communicating purging gas into the vacuum chamber in upwardly and downwardly directed flows merging about the periphery of the substrate and moving radially outwardly thereof for confining the reactive deposition species to the substrate.

8. The process of claim 1, 2, 3, 4 or 5, further comprising communicating an inert gas into the chamber.

9. The process of claim 8, wherein the inert gas is communicated into the gas inlet manifold.

10. The process of claim 8, further comprising communicating purging gas into the vacuum chamber in upwardly and downwardly directed flows merging about the periphery of the substrate and moving radially outwardly thereof for confining the reactive deposition species to the substrate.

11. The process of claim 9, further comprising communicating purging gas into the vacuum chamber in upwardly and downwardly directed flows merging about the periphery of the substrate and moving radially outwardly thereof for confining the reactive deposition species to the substrate.

12. In a process of depositing silicon dioxide onto a substrate by exposing the substrate to reactive deposition species resulting from the decomposition of tetraethylorthosilicate in an oxidizing plasma, the steps of positioning the substrate on a support within a vacuum chamber and adjacent a manifold which is an RF electrode and which includes a multiplicity of closely-spaced outlet holes closely adjacent the substrate; and communicating tetraethylorthosilicate and an oxidizing species into the chamber via the manifold holes while applying RF energy between the manifold and the substrate support and maintaining the total pressure in the chamber within the range of about 1 to 50 torr so that a layer of silicon oxide is deposited onto the substrate at a deposition rate greater than 400 angstroms per minute, said silicon oxide layer quality and step coverage being adequate for VLSI semiconductor fabrication.

13. In a process for depositing silicon dioxide onto a substrate by exposing the substrate to plasma formed from a gas mixture which includes tetraethylorthosilicate, the steps of:

positioning the substrate on a support within a vacuum chamber;

communicating the gas mixture into the chamber to a first volume adjacent the substrate;

directing the gas mixture from said first volume in a multiplicity of closely-spaced streams through a second volume between the first volume and the substrate while applying RF energy to the second volume; and

maintaining the total pressure in the chamber within the range of about 1 to 50 torr and the temperature of the substrate in the range of about 200° C to 500° C, whereby a layer of silicon dioxide having improved step coverage is deposited onto the substrate with a deposition rate greater than 400 angstroms per minute, said silicon oxide layer quality and step coverage being adequate for VLSI semiconductor fabrication.

14. The process of claim 13 wherein the deposition of silicon dioxide onto the substrate is at a rate equal or greater than 5000 Angstroms per minute.

15. In a process of depositing silicon dioxide onto a substrate by exposing the substrate to reactive deposition species resulting from the decomposition of tetraethylorthosilicate in an oxidizing plasma, the steps of:

positioning the substrate on a support within a vacuum chamber;

communicating tetraethylorthosilicate and an oxidizing species into the chamber to a first volume adjacent the substrate;

directing the gas mixture from said first volume in a multiplicity of closely-spaced streams through a second volume between the first volume and the substrate while applying RF energy to the second volume; and

maintaining the total pressure in the chamber within the range of about 1 to 50 torr, whereby a layer of silicon dioxide having improved step coverage is deposited onto the substrate with a deposition rate greater than 400 angstroms per minute, said silicon oxide layer quality and step coverage being adequate for VLSI semiconductor fabrication.

16. The process according to claim 15 wherein the step of directing distributes the gas with a substantially uniform spatial distribution over the surface of the substrate.

17. The process according to claim 15 wherein the step of directing includes directing the gas mixture from the first volume in a direction substantially perpendicular to the substrate.

18. The process according to claim 15 wherein the step of directing includes applying a ground potential for the RF energy to the substrate.

19. The process according to claim 15 wherein the RF power is applied at the frequency of approximately 13.5 MHz.

20. The process according to claim 15 wherein the chamber pressure is about 1 to 12 torr.

21. The process according to claim 15 wherein the gas mixture includes oxygen.

22. The process according to claim 15 further comprising the steps of

gasifying liquid TEOS and

including the gasified TEOS in said gas mixture.

23. The process of claim 15 wherein the deposition of silicon dioxide onto the substrate is at a rate substantially greater than 400 Angstroms per minute.

24. The process of claim 15 wherein the deposition of silicon dioxide onto the substrate is at a rate equal or greater than 5000 Angstroms per minute.

25. The process according to claim 13 wherein the step of directing includes applying a ground potential for the RF energy to the substrate.

26. The process according to claim 13 wherein the RF power is applied at the frequency of approximately 13.5 MHz.

27. The process according to claim 13 wherein the chamber pressure is about 1 to 12 torr.

28. The process according to claim 13 wherein the gas mixture includes oxygen.

29. The process according to claim 13, further comprising the steps of gasifying liquid TEOS and including the gasified TEOS in said gas mixture.

30. The process according to claim 13 wherein the step of directing distributes the gas with a substantially uniform spatial distribution over the surface of the substrate.

31. The process according to claim 13 wherein the step directing includes directing the gas mixture from the first volume in a direction substantially perpendicular to the substrate.

32. The process of claim 1 wherein the deposition of silicon dioxide onto the substrate is at a rate substantially greater than 400 Angstroms per minute.

33. The process of claim 1 wherein the deposition of silicon dioxide onto the substrate is at a rate equal or greater than 5000 Angstroms per minute.

34. The process of claim 12 wherein the deposition of silicon dioxide onto the substrate is at a rate substantially greater than 400 Angstroms per minute.

35. The process of claim 12 wherein the deposition of silicon dioxide onto the substrate is at a rate equal or greater than 5000 Angstroms per minute.

36. The process of claim 13 wherein the deposition of silicon dioxide onto the substrate is at a rate substantially greater than 400 Angstroms per minute.

* * * * *