



US00RE36465E

United States Patent [19] **Boisture**

[11] E

Patent Number: Re. 36,465

[45] **Reissued Date of Patent: Dec. 28, 1999**

[54] **FURNACE CLEANING APPARATUS**

[75] Inventor: **Thomas B. Boisture**, Baytown, Tex.

[73] Assignee: **C.H. Heist Corp.**, Clearwater, Fla.

[21] Appl. No.: **08/755,778**

[22] Filed: **Nov. 22, 1996**

3,541,999	11/1970	Winkin	122/392
3,571,985	3/1971	Hulbert, Jr.	51/319
3,599,871	8/1971	Ruppel et al.	239/227
3,645,452	2/1972	Stoeckel	239/227
3,661,124	5/1972	Winkin	122/392
3,696,825	10/1972	Guignon et al.	134/167 R
3,701,341	10/1972	Willis, Jr.	122/392
3,741,808	6/1973	Stalker	134/58 R
3,817,262	6/1974	Caradeur et al.	134/167

(List continued on next page.)

Related U.S. Patent Documents

Reissue of:

[64] Patent No.: **5,381,811**
 Issued: **Jan. 17, 1995**
 Appl. No.: **08/204,583**
 Filed: **Mar. 2, 1994**

FOREIGN PATENT DOCUMENTS

304178	5/1971	U.S.S.R.	239/752
486925	10/1975	U.S.S.R.	239/752
650678	3/1979	U.S.S.R.	134/167 R

- [51] **Int. Cl.**⁶ **B08B 3/02**
 [52] **U.S. Cl.** **134/22.1; 134/24; 134/167 R; 134/181; 239/752; 901/1**
 [58] **Field of Search** **134/167 R, 181, 134/180, 172, 198, 104.1, 201, 22.1, 22.11, 24; 901/1, 16; 118/302, 323; 239/750, 751, 752, 264**

OTHER PUBLICATIONS

- Helac Corp., PH Series Planetary Hydraulic Rotary Actuators Catalog, undated, 16 pages.
 Helac Corp., Helical Rotary Actuators Catalog, 1987, 20 pages.
 Stone Age Waterjet Engineering, Two drawings of Oscillating Cyclone Cleaner, May 6 & 10, 1993.

[56] References Cited

U.S. PATENT DOCUMENTS

471,931	3/1892	Young, Jr. .	
661,417	11/1900	Mossman .	
690,878	1/1902	Roan .	
1,549,415	8/1925	Hafer .	
1,628,141	5/1927	Gray .	
1,928,621	10/1933	Frede et al. .	
2,109,075	2/1938	Ruth	299/67
2,344,108	3/1944	Roselund	91/45
2,497,171	2/1950	Jones et al.	134/24
2,710,225	6/1955	Richards	239/264
2,945,628	7/1960	Broughton	239/264
3,001,534	9/1961	Grant, Jr.	134/167
3,101,730	8/1963	Harris et al.	134/167
3,225,777	12/1965	Shelton et al.	134/141
3,247,969	4/1966	Miller	210/169
3,358,935	12/1967	Andersen et al.	239/589
3,389,713	6/1968	Pittman	134/167
3,440,096	4/1969	Scott	134/24
3,461,889	8/1969	Saxonmeyer	134/43
3,477,178	11/1969	Hulbert, Jr.	51/8

Primary Examiner—Frankie L. Stinson
Attorney, Agent, or Firm—Hudak & Shunk Co., L.P.A.;
 Laura F. Shunk

[57] ABSTRACT

A furnace cleaning apparatus for cleaning a cyclone furnace with a fluid from a fluid source. The furnace cleaning apparatus comprises a beam assembly capable of being pivotably mounted to the cyclone furnace. A rotary actuator is connected to the beam assembly for turning the beam assembly. A trolley is movably mounted to the beam assembly. A chain drive assembly and a drive source for moving the trolley relative to the beam assembly are mounted to the beam assembly. An articulated arm assembly is pivotally connected to the trolley. A rotary actuator is mounted to the articulated arm assembly for pivoting the articulated arm assembly relative to the trolley. A nozzle is connected to a second end of the articulated arm assembly. A fluid conduit connects the nozzle to a fluid source.

29 Claims, 3 Drawing Sheets

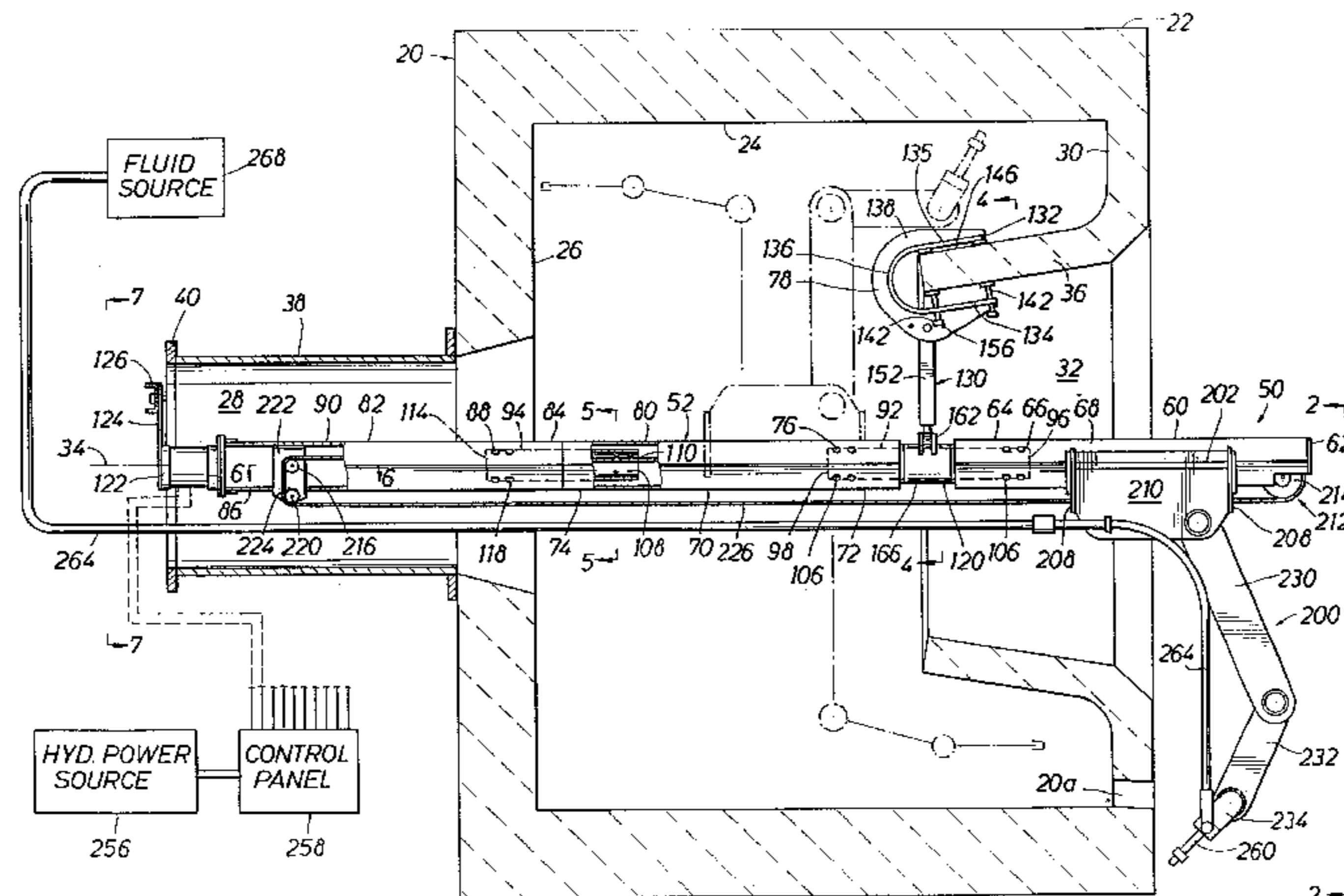

U.S. PATENT DOCUMENTS

3,836,434	9/1974	Novy	201/2	4,503,811	3/1985	Hammond	122/392
3,878,857	4/1975	Heibo	134/167 R	4,522,170	6/1985	Lenk	123/198 DC
3,895,756	7/1975	Jaeger	239/227	4,527,515	7/1985	Hester, II	122/392
3,961,983	6/1976	Crandall et al.	134/8	4,574,825	3/1986	Haug	134/167 R
3,973,988	8/1976	McMahan	134/46	4,603,661	8/1986	Nelson et al.	122/392
3,987,963	10/1976	Pacht	239/124	4,605,028	8/1986	Paseman	134/167
4,064,656	12/1977	Zeidler	51/426	4,646,768	3/1987	Tanaka et al.	134/167 R
4,080,761	3/1978	Burns	51/438	4,690,159	9/1987	Vadakin et al.	134/167 C
4,095,305	6/1978	Goodwin	15/104.1 R	4,803,959	2/1989	Sherrick et al.	122/379
4,135,068	1/1979	Burns	200/61.85	4,805,650	2/1989	Yasui	134/57 R
4,163,455	8/1979	Hebert et al.	134/167 R	4,859,249	8/1989	Valentini	134/22.18
4,170,192	10/1979	Maddock	118/306	4,938,167	7/1990	Mizuho	118/713
4,212,248	7/1980	Maybury	104/138 G	4,945,862	8/1990	Vadakin	122/392
4,219,976	9/1980	Burack	51/411	5,038,810	8/1991	Pacheco et al.	134/167 C
4,220,170	9/1980	Hebert	134/167 R	5,069,172	12/1991	Shirey et al.	122/382
4,244,523	1/1981	Looper	239/227	5,095,929	3/1992	Harvey	134/167 R
4,256,511	3/1981	Atchison	134/46	5,107,873	4/1992	Clinger	134/56 R
4,273,076	6/1981	Lahoda et al.	122/382	5,113,885	5/1992	Ramsey	134/167 C
4,276,856	7/1981	Dent et al.	122/382	5,172,653	12/1992	Vadakin	122/392
4,301,998	11/1981	Rodway	266/281	5,279,675	1/1994	Verbeek	134/22.1
4,326,317	4/1982	Smith et al.	15/302	5,293,887	3/1994	Thibodeaux	134/24
4,332,062	6/1982	Byrne, Jr.	24/263 DA	5,301,702	4/1994	McKinney	134/167 R
4,341,232	7/1982	Maton	134/107	5,352,298	10/1994	Moulder	134/22.18
4,354,294	10/1982	Silver	15/317	5,392,798	2/1995	Hirose	134/167 R
4,407,236	10/1983	Schukei et al.	122/390	5,460,193	10/1995	Levallois	134/56 R
4,445,465	5/1984	Byrd et al.	122/392	5,482,063	1/1996	Miura	145/56 R
4,498,427	2/1985	Todd	122/379	5,518,553	5/1996	Moulder	134/22.18

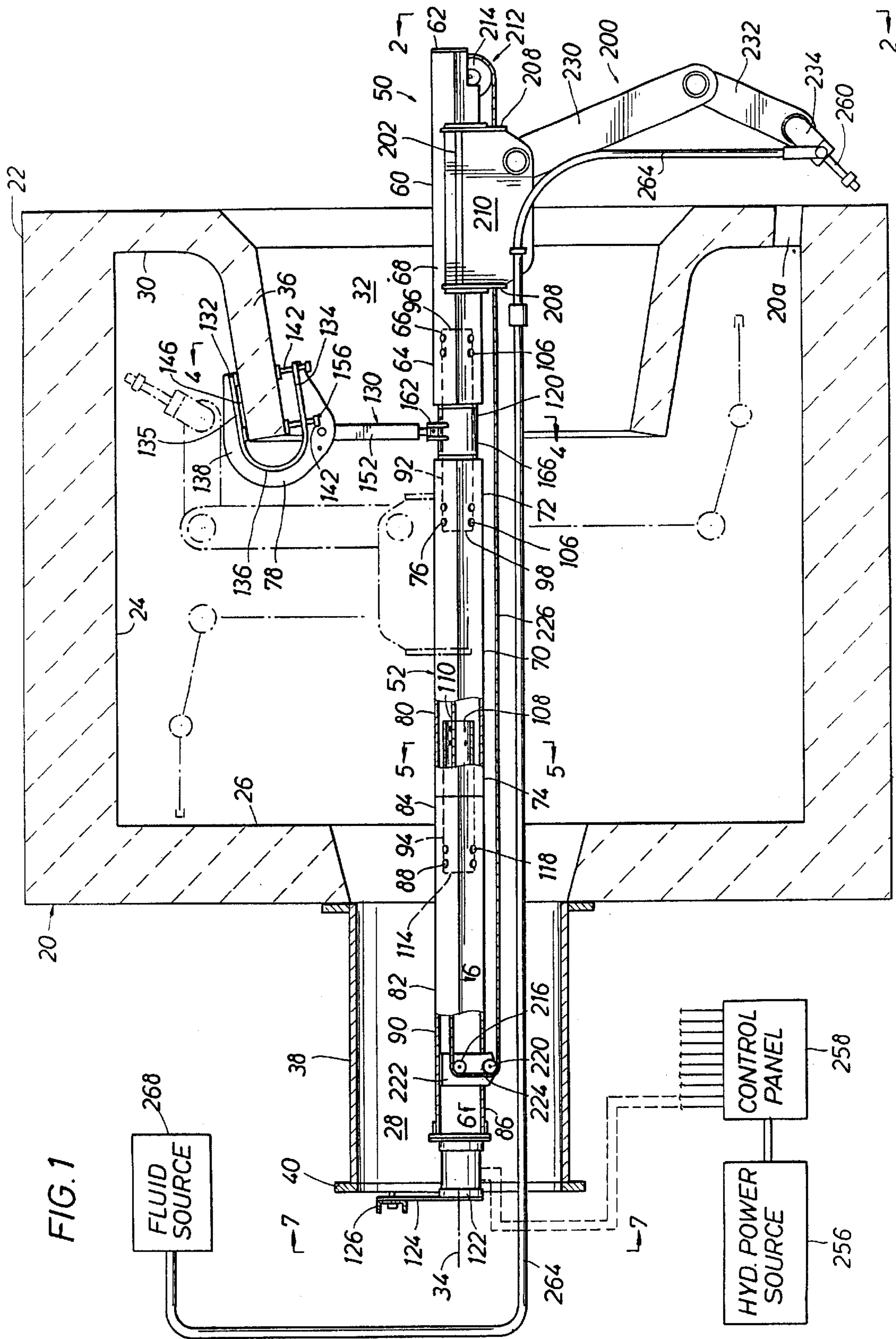

FIG. 2

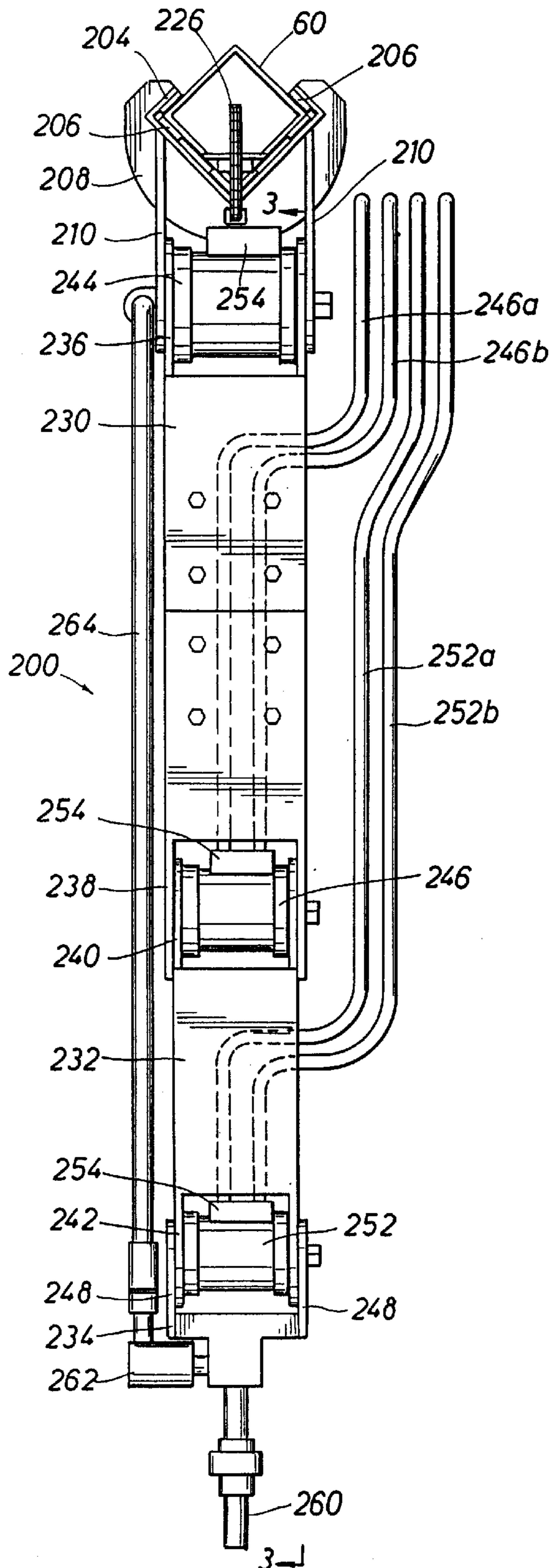
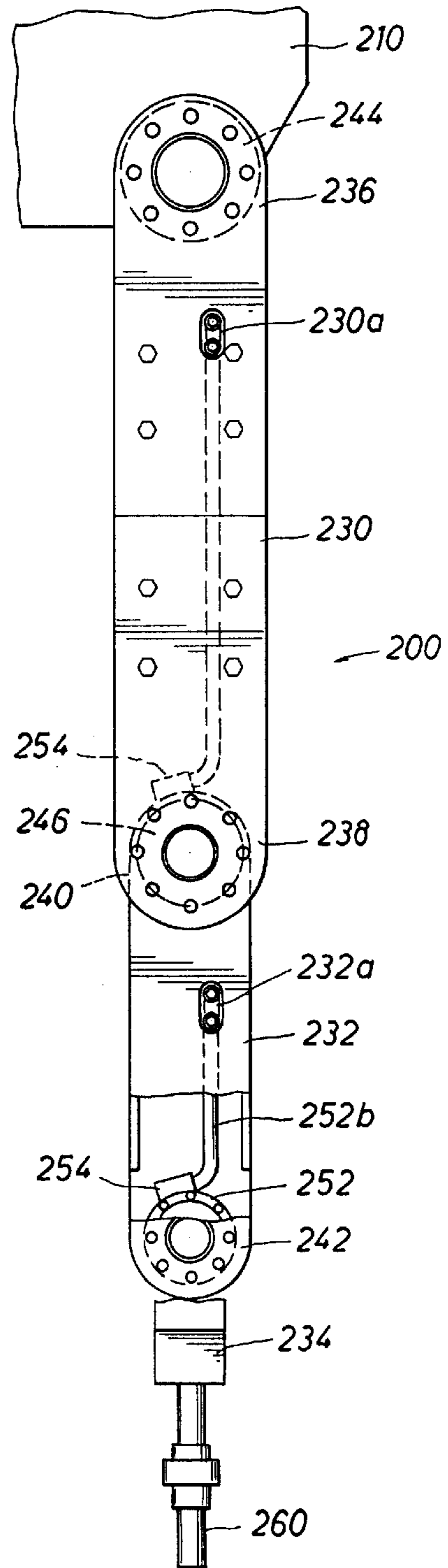
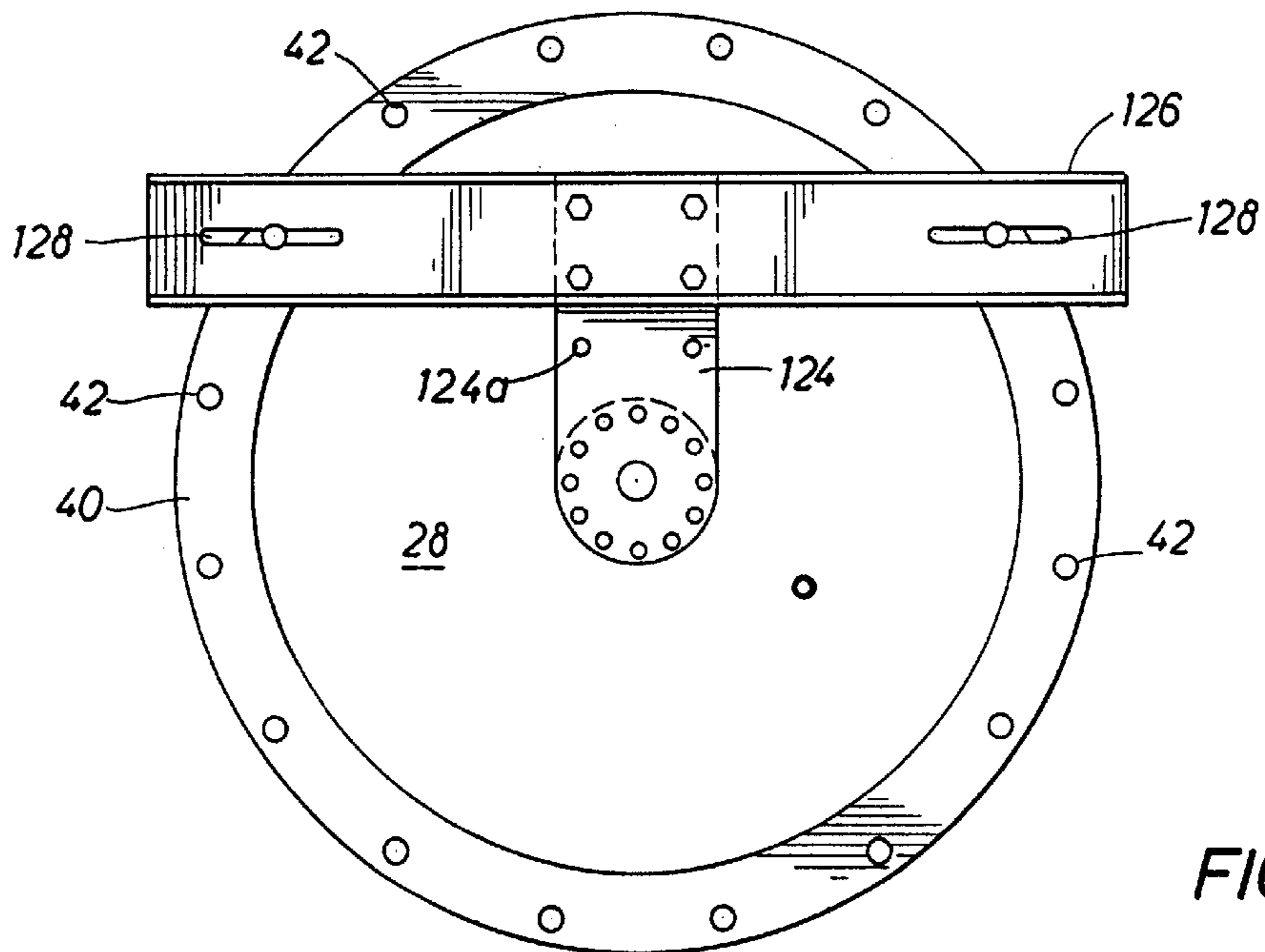
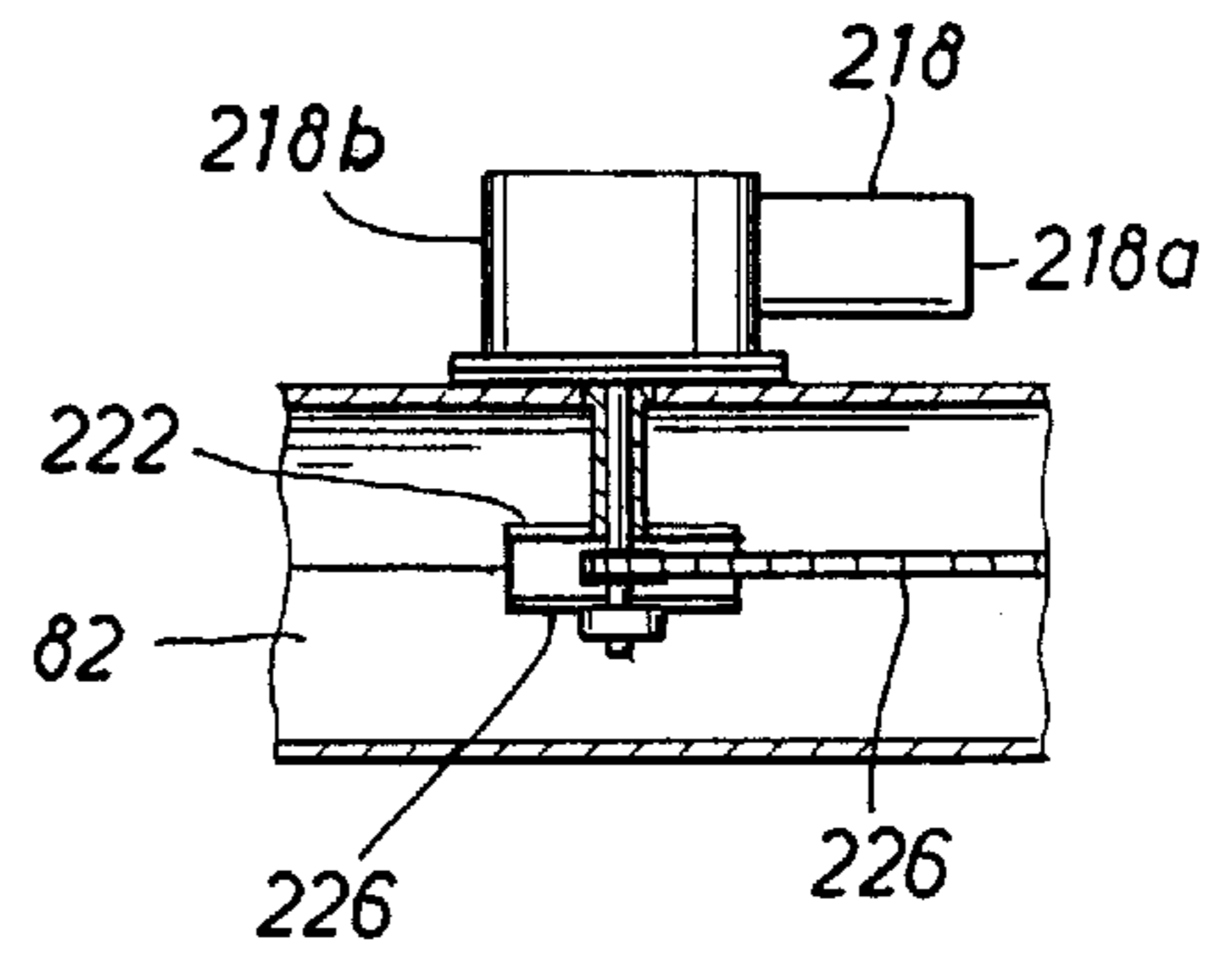
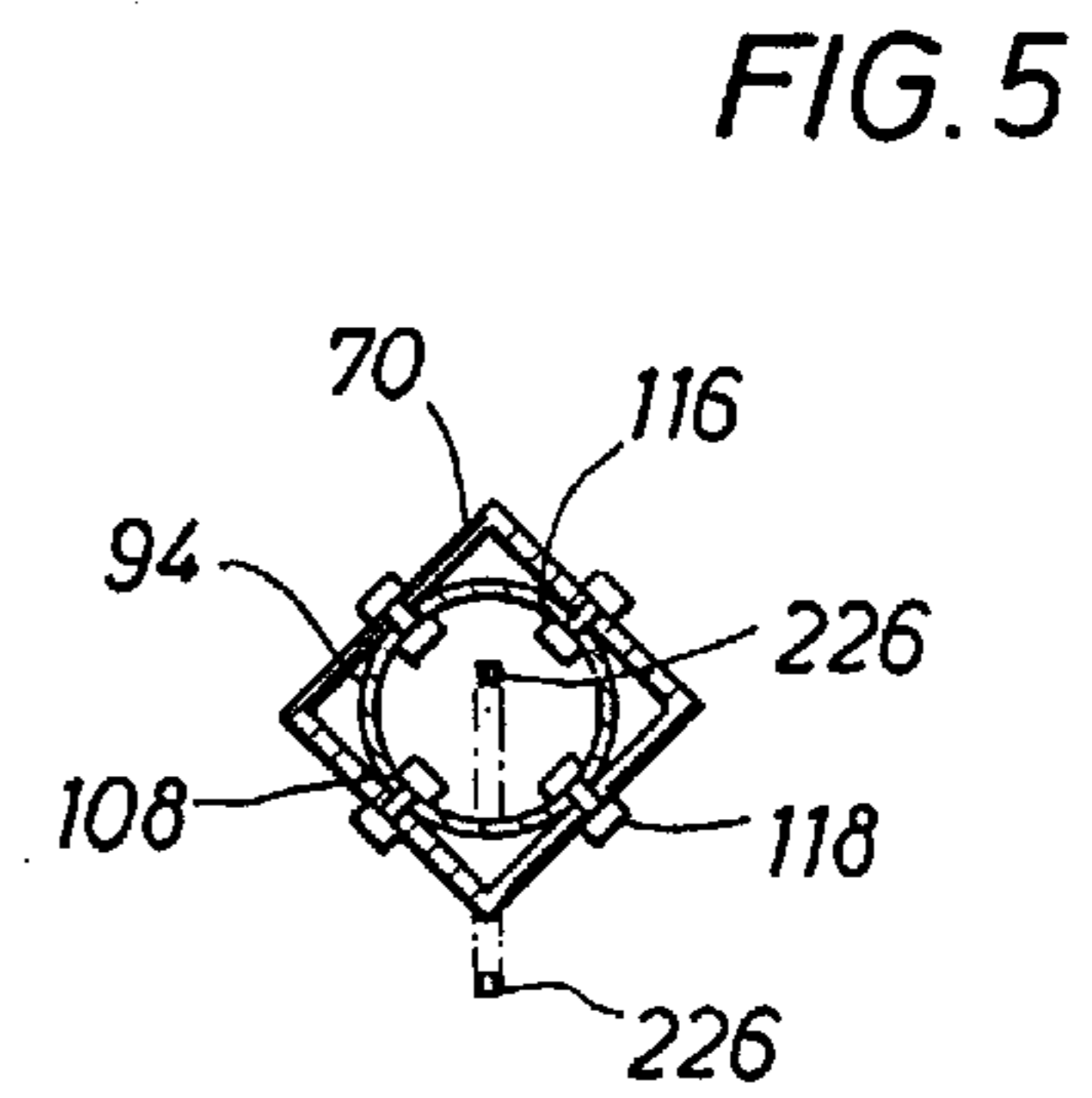
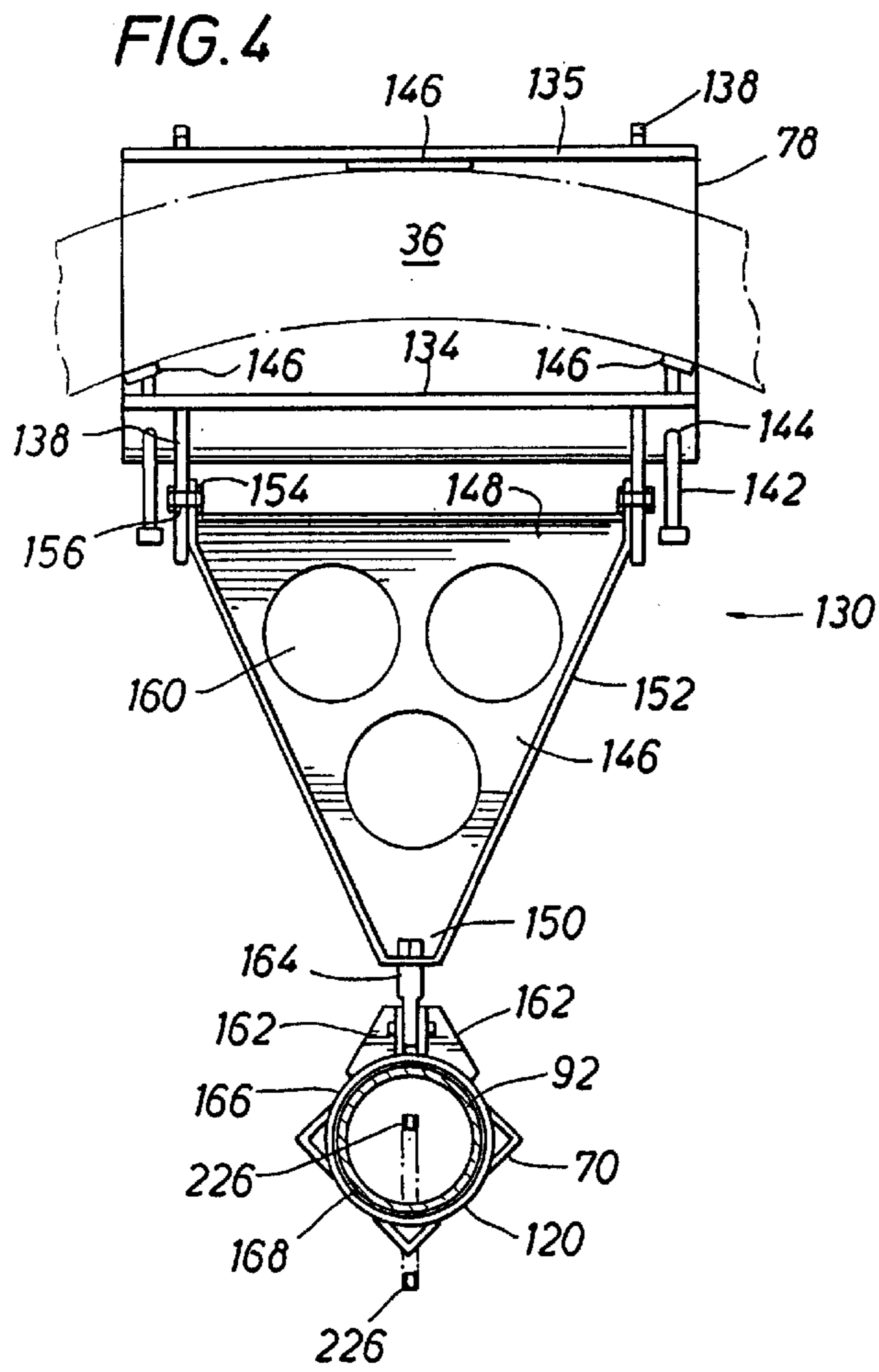

FIG. 3





FURNACE CLEANING APPARATUS

Matter enclosed in heavy brackets [] appears in the original patent but forms no part of this reissue specification; matter printed in italics indicates the additions made by reissue.

BACKGROUND OF THE INVENTION

1. Field of the Invention

The present invention relates to a cleaning apparatus for cleaning the interior surface of a housing such as a cyclone furnace or boiler.

2. Description Of the Prior Art.

Coal fired boilers are commonly used in industry, Pulverized coal is fed into a boiler-through a cyclone burner which receives the pulverized coal from a feeder apparatus connected to the inlet of the cyclone burner. Initial burning of the coal occurs inside the cyclone burner with further burning occurring in the boiler. The boiler is typically a water-cooled horizontal cylinder. Air with a velocity of approximately 300 feet per second is admitted tangentially at the roof of the main barrel of the cyclone furnace and imparts a further whirling or centrifugal action to the coal particles. The combustible is burned at temperatures sufficiently high to melt the ash into a liquid slag, which forms a layer on the interior walls of the cyclone furnace. Incoming coal particles are thrown to the interior walls by centrifugal force and held in the slag. The coal particles are then scrubbed by the high-velocity tangential air.

The interior walls of the cyclone furnace accumulate slag deposits from the burning coal particles. The slag deposits may sometimes be as much as three feet thick. It is well known that some amount of slag is beneficial to the combustion although too much slag is detrimental. Therefore, the interior walls of the cyclone furnace need periodic cleaning to reduce the slag deposits to the desired thickness.

U.S. Pat. No. 4,673,661 to Nelson et al. discloses a semi-automated cyclone furnace cleaning apparatus requiring an operator to enter the cyclone furnace and rearrange or replace high pressure fluid nozzles in order to clean the various inside surfaces of the cyclone furnace.

U.S. Pat. No. 5,107,873 to Clinger discloses an apparatus similar to that described in the '661 patent. The apparatus disclosed in the '661 patent and the '873 patent includes a pair of diametrically opposed lances which are intended to move transversely to the longitudinal axis of the cyclone furnace and includes a nozzle arrangement to provide either a longitudinal spray or a transverse spray normal to the direction of the longitudinal spray.

It is desirable to have a furnace cleaning apparatus which provides maximum versatility in the cleaning operations of the cyclone furnace. It is further desirable to be able to adjust the angle of the fluid spray against the cyclone furnace walls. It is also desirable that the furnace cleaning apparatus be capable of simultaneously moving longitudinally in the cyclone furnace while rotating about the longitudinal axis of the cyclone furnace and further being capable of simultaneous reorientation of the direction of the nozzle spray.

SUMMARY OF THE INVENTION

The present invention is a furnace cleaning apparatus providing maximum versatility in the cleaning operations of a cyclone furnace. The furnace cleaning apparatus is capable of moving longitudinally in the cyclone furnace while oscillating through approximately one revolution about the

longitudinal axis thereof and furthermore is capable of simultaneously reorienting the direction of the nozzle spray. The furnace cleaning apparatus is transportable and capable of being assembled within the interior of the cyclone furnace. The apparatus uses high pressure hydroblasting techniques to remove slag deposits from the interior walls of the cyclone furnaces.

The furnace cleaning apparatus includes an oscillating beam assembly capable of being supported by the cyclone furnace. A trolley is movably mounted to the beam assembly and is permitted to move longitudinally relative to the beam assembly. An articulated arm assembly is pivotally connected to the trolley. A nozzle assembly is mounted to the opposite end of the articulated arm assembly. The furnace cleaning apparatus is controlled from an exterior control panel. The direction of the nozzle spray, the configuration of the articulated arm assembly, the axial positioning of the trolley relative to the beam assembly, and the angular rotation of the beam assembly are all controlled from the control panel.

The more important features of this invention have been summarized rather broadly in order that the detailed description may be better understood. There are, of course, additional features of the invention which will be described hereafter and which will also form the subject of the claims appended hereto.

BRIEF DESCRIPTION OF THE DRAWINGS

In order to more fully understand the drawings referred to in the detailed description of the present invention, a detailed description of each drawing is presented, in which:

FIG. 1 is a schematic elevational view, partially in section, of the furnace cleaning apparatus of the present invention mounted to a cyclone furnace;

FIG. 2 is an end view taken along line 2—2 of FIG. 1;

FIG. 3 is a view taken along line 3—3 of FIG. 2;

FIG. 4 is a view taken along line 4—4 of FIG. 1;

FIG. 5 is a view taken along line 5—5 of FIG. 1;

FIG. 6 is a view taken along line 6—6 of FIG. 1; and

FIG. 7 is an end view taken along line 7—7 of FIG. 1.

DETAILED DESCRIPTION OF PREFERRED EMBODIMENT

Referring to FIG. 1, a cyclone furnace, designated generally as reference numeral 20, includes a main barrel 22 which is generally cylindrical. Typically, the main barrel 22 of the cyclone furnace 20 has a diameter ranging from 5 to 10 feet. Generally, the cyclone furnace 20 includes a cylindrical sidewall 24, a first end wall 26 having an inlet opening 28, and a second end wall 30 having an outlet opening 32. The inlet and outlet openings 28 and 32, respectively, are generally axially aligned on a longitudinal axis 34 of the cyclone furnace 20. Typically, the outlet opening 32 is defined by an outlet wall 36 extending inwardly into the cyclone furnace 20 in a frustoconical shape as shown in FIG. 1.

Typically, the inlet opening 28 is defined by a substantially cylindrical portion 38 extending outwardly from the main barrel 22 of the cyclone furnace 20 at the first end wall 26. The cylindrical portion 38 typically includes an inlet flange 40 as shown in FIGS. 1 and 2. The inlet flange 40 includes a plurality of equidistantly spaced holes 42 for receiving threaded fasteners to mate with another flange member.

Referring to FIG. 1, the improved furnace cleaning apparatus, designated generally as reference numeral 50, includes a beam assembly 52 comprising a front beam 60, a mid beam 70, and a rear beam 82. The beam assembly 52 is supported by the cyclone furnace 20 at two locations. Preferably, the beam assembly 52 is supported such that a longitudinal axis of the beam assembly 52 substantially coincides with the longitudinal axis 34 of the cyclone furnace 22.

The front beam 60 has a front end 62 and a splice end 64. In the preferred embodiment, the front beam 60 is made of square structural tubing having square corners. The front beam 60 includes a plurality of holes 62 through the wall 68 of the front beam 60.

The mid beam 70 has a cross-section similar to the front beam 60. The mid beam 70 has a splice end 72 and a mid end 74. A plurality of holes 76 extend through the wall 80 near the splice end 72 and mid end 74, respectively, of the mid beam 70.

The rear beam 82 has a mid end 84 and a rear end 86. A plurality of holes 88 extend through the wall 90 of the rear beam 82 near the mid end 84.

Preferably, the front, mid, and rear beams 60, 70, and 82, respectively, are made of aluminum and are square tubing having dimensions of 6"x6"x0.250". However, such members may be of any reasonable dimension suitable for the purpose and may be of various lengths to accommodate the length of the cyclone furnace 20 being cleaned.

As shown in FIG. 1, the front beam 60 is connected to the mid beam 70 with a splice tube 92. The mid beam 70 is connected to the rear beam 82 with a mid tube 94. In the preferred embodiment the splice tube 92 and the mid tube 94 are tubular members of round cross-section capable of close sliding engagement within the front, mid and rear beams 60, 70 and 82, respectively.

Referring to FIG. 1, the mid tube 94 has a mid end 110 and a rear end 114. The mid tube 94 includes a plurality of holes 108 at the mid end 110 and the rear end 114. The plurality of holes 108 at the mid end 110 are adapted to be aligned with the plurality of holes 76 in the mid beam 70. Similarly, the plurality of holes 108 in the rear end 114 of the mid tube 94 are adapted to be aligned with the plurality of holes 88 in the rear beam 82. Preferably, a threaded nut 116 is tack welded to the inside of the mid tube 94 over each of the plurality of holes 108 as shown in FIG. 5. Thus, during the assembly of the beam assembly 52, a plurality of belts 118 can be inserted through the holes in the beam members and the mid tube and threadably engaged with the aligned nuts 116 in the mid tube.

Referring to FIG. 1, the splice tube 92 has a front end 96 and a mid end 98. A plurality of holes (not shown) at the front end 96 are adapted to be aligned with the plurality of holes 66 in the front beam 60. Similarly, a plurality of holes (not shown) in the mid end 98 of the splice tube 92 are adapted to be aligned with the plurality of holes 76 in the mid beam 70. Preferably, a threaded nut (not shown) is tack welded to the inside of the splice tube 92 over each of the plurality of holes (not shown). Thus, during the assembly of the beam assembly 52, a plurality of bolts 106 can be inserted through the holes in the beam members and the splice tube and threadably engaged with the aligned nuts (not shown).

As shown in FIG. 1, preferably the mid beam 70 is in generally contacting engagement with the rear beam 82 in the assembled beam assembly 52. The mid tube 94 has a length sufficient to maintain the axial alignment of the mid

beam 70 with the rear beam 82. The angular alignment of the beams 70 and 82 is maintained by the bolted connection of the beams 70 and 82 to the mid tube 94. The splice tube 92 maintains the front beam 60 a fixed distance from the mid beam 70. A rotational bearing assembly 120 is mounted on the splice tube 92 between the front and mid beams 60 and 70, respectively. Preferably, the splice tube 92 is a seamless alloy steel tube. The splice tube 92 has a length sufficient to maintain the axial alignment of the mid beam 70 with the front beam 60. The angular alignment of the beams 70 and 60 is maintained by the bolted connection of the beams 70 and 60 to the splice tube 92.

It is important to understand that in the assembled condition, the square tubing beams 60, 70 and 82 of the beam assembly 52 are all angularly and longitudinally aligned for reasons which will be explained below.

As previously mentioned, the beam assembly 52 is supported by the cyclone furnace 20 at two locations, those being a rear location and an intermediate location. A trunnion assembly 122 is attached to the rear end 86 of the rear beam 82 as shown in FIG. 1. The trunnion assembly 122 is further attached to a rear hanger 124. The rear hanger 124 is a plate which is connected to a crossbar 126. The crossbar 126 is preferably a channel member having a pair of openings 128 therethrough. The openings 128 are aligned with a pair of holes 42 in the inlet flange 40 and then bolt connected to the cyclone furnace 20. It may be desirable to make the openings 128 elongated slots so as to enable the crossbar 126 to be used with a variety of inlet flange diameters. It may also be desirable to make the connection between the crossbar 126 and the rear hanger 124 a bolted connection with slots or pairs of holes 124a to enable vertical adjustment of the longitudinal axis of the beam assembly 52 to substantially coincide with the longitudinal axis 34 of the cyclone furnace 20.

Preferably, the trunnion assembly 122 is a rotary actuator as manufactured by Helac Corporation of Enumclaw, Wash. A rotary actuator exerts substantially constant torque through its limited angle of rotation. Preferably, the rotary actuator is hydraulically controlled and includes the feature of direct mounted dual pilot check valves.

The beam assembly 52 is supported at the intermediate location by a clamp 78 and intermediate hanger assembly 130. The clamp 78 includes a generally U-shaped member 132. The U-shaped member 132 includes a lower leg 134 and an upper leg 135 which are joined by a semicircular section 136. A pair of generally U-shaped stiffening plates 138 are secured to the outer surface of the legs 134, 135 and the semicircular section 136. The legs 134, 135 are parallel to one another and are a fixed distance from one another. The fixed distance is sufficient to permit the U-shaped member 132 to be installed onto the outlet wall 36 as shown in FIGS. 1 and 4. Preferably, an upper bearing pad 146 is attached to the lower face of the upper leg 135 along a centerline between the pair of U-shaped stiffening plates 138. The bearing pad 146 bears against the outlet wall 36 and helps to distribute the loading when the clamp 78 is tightened down against the outlet wall 36 as will be explained below.

The lower leg 134 includes a pair of threaded fasteners or bolts 142 inserted through threaded holes 144 located near the ends of the lower leg 134. Each bolt 142 has a swivel pad 146 attached to its extremity. The threaded advancement of the bolt 142 in the threaded hole 144 causes the swivel pad 146 to make contact with the curved surface of the outlet wall 36 as shown in FIG. 4. The clamp 78 securely engages the outlet wall 36 by advancing the bolts 142 until all of the

swivel pads firmly grip the outlet wall **36** with the bearing pad **140** in bearing contact with the outlet wall **36**.

As shown in FIG. 4, the intermediate hanger assembly **130** includes a generally triangular-shaped plate **146** having an upper end **148** and a lower end **150**. The triangular-shaped plate **146** includes a peripheral flange **152** attached to the perimeter of the triangular-shaped plate **146**. The flange **152** includes a pair of holes **154** near the upper end **148** of the intermediate hanger assembly **130**. The intermediate hanger assembly **130** is connected at its upper end **148** to the pair of stiffening plates **138**. The pair of stiffening plates **138** include one or more holes **156** for receiving a fastening member **158**, as for example a pin or threaded bolt. The holes **154** align with the holes **156** and the fastening members **158** are inserted therethrough to secure the intermediate hanger assembly **130** to the clamp **78**.

Referring to FIG. 1, it may be desirable to include a plurality of holes **156** in each stiffening plate **138** to allow various positioning of the intermediate hanger assembly **130** which may be necessary due to different configurations and/or lengths of cyclone furnaces **20**.

It is to be further understood that the required length of beam assembly **52** may vary depending on the size and type of cyclone furnace **20** being cleaned. Thus, it is anticipated that various lengths of beam assemblies **52** can be provided by substituting one of the beams **60**, **70** or **82** with a beam of the appropriate length. Preferably, the mid beam **70** would be the substituted beam due to its simplicity relative to the front and rear beams **60** and **82**, respectively, as will be explained below. Alternatively, the various lengths of beam assemblies **52** can be achieved by providing a series of mid beams differing in length by 6" and providing a plurality of shims (not shown) to be used between the crossbar **126** and the inlet flange **40**, if needed.

As shown in FIG. 4, the triangular-shaped plate **146** preferably includes one or more openings **160** therethrough to reduce the weight of intermediate hanger assembly **130**.

Referring to FIGS. 1 and 4, the rotational bearing assembly **120** is connected to the lower end **150** of the intermediate hanger assembly **130**. A pair of opposing connecting flanges **162** are attached to the rotational bearing assembly **120**. A pin **164** extends from the lower end of the intermediate hanger assembly **130** and is pin-connected to the connecting flanges **162** of the rotational bearing assembly **120**.

Referring to FIGS. 1 and 4, the rotational bearing assembly **120** comprises a round tubular section **166** having a length less than the distance between the front beam **60** and the mid beam **70** in the assembled condition. The round tubular section **166** has an inside diameter greater than the outside diameter of the splice tube **92** so that the round tubular section **166** can be installed over the splice tube **92**. Preferably, the round tubular section is made of steel. In the preferred embodiment, a friction reducing sleeve **168** is positioned between the round tubular section **166** and the splice tube **92**. Preferably, the friction reducing sleeve is made of an ultra high molecular weight plastic.

The furnace cleaning apparatus **50** further includes an articulated arm assembly **200** attached to a trolley **202**. The trolley **202** is mounted to the beam assembly **52**. As shown in FIG. 2, the trolley **202** comprises a partial square tubing member **204** sized to circumscribe at least three of the four corners of the square tubing of the beam assembly **52**. A bearing assembly **206**, as for example a roller bearing assembly, is mounted inside the partial square tubing member **204** to enable longitudinal movement of the trolley **202** along the beam assembly **52** as indicated in FIG. 1. The

trolley **202** includes a pair of end plates **208** attached to the partial square tubing member **204**. A pair of side plates **210** are attached to the end plates **208** and extend from approximately the two corners of the partial square tubing member **204** which are opposite one another as shown in FIG. 2.

The trolley **202** is advanced along the beam assembly **52** by a chain drive assembly **212** as shown in FIG. 1. Referring to FIGS. 1 and 2, a front sprocket **214** is rotatably mounted within the front end **62** of the front beam **60**. The front beam **60** has a cutout portion to permit the front sprocket **214** to extend beyond the periphery of the front beam **60**. Referring to FIGS. 1 and 6, the rear beam **82** includes a drive sprocket **216** rotatably mounted between a pair of mounting brackets **222** in the rear beam **82**. The drive sprocket **216** is connected to a drive source **218** such as a hydraulically controlled motor **218a** and gearbox **218b** assembly. A secondary sprocket **220** is mounted to the outside of the rear beam **82** between the pair of mounting brackets **222**. The rear beam **82** includes a window **224** for allowing a chain **226** to pass from within the rear beam **82** to outside of the rear beam **82**. The chain **226** passes from the drive sprocket **216** to the secondary sprocket **220** to the front sprocket **214** and then back to the drive sprocket **216** with the portion between the front sprocket **214** and the drive sprocket **216** being within the beam assembly **52** as shown in FIG. 1. The portion of the chain **226** within the beam assembly **52** passes through the splice and mid tubes **92** and **94**, respectively.

The chain **226** passes through the end plates **208** of the trolley **202**. The chain **226** is securely attached to the trolley **202**. Preferably, the chain **226** has two ends which are each securely connected to the trolley **202**. Thus, as the drive sprocket **216** rotates, the endless chain **226** moves and slides the trolley **202** longitudinally along the beam assembly **52**.

The articulated arm assembly **200** is rotatably mounted to the trolley **202** between the pair of side plates **210** as shown in FIG. 2. Referring to FIGS. 1, 2, and 3, the articulated arm assembly **200** has an elbow tube **230**, a forearm tube **232**, and a wrist assembly **234**. The articulated arm assembly **200** is preferably fabricated from square tubing. The elbow tube **230** has a first end portion **236** and a second end portion **238**. The elbow tube end portions **236** and **238** have a pair of opposing faces removed at the location of the joint connection. The elbow tube **230** is sized so that its first end portion **236** fits within the pair of trolley side plates **210** as shown in FIG. 2. An elbow rotating means **244** is provided at the joint formed between the side plates **210** and the elbow tube **230** to provide rotational movement of the elbow tube **230** relative to the trolley **202**.

The forearm tube **232** similarly has a first end portion **240** and a second end portion **242**. Similarly, the forearm tube end portions **240** and **242** have a pair of opposing faces removed at the location of the joint connection. The forearm tube **232** is sized so that its first end portion **240** fits within the second end portion **238** of the elbow tube **230**. A forearm rotating means **246** is provided at the joint formed between the elbow tube **230** and the forearm tube **232** to provide rotational movement of the forearm tube **232** relative to the elbow tube **230**.

The wrist assembly **234** includes a pair of spaced apart wrist plates **248** connected to a tee member **250**. The spaced apart wrist plates **248** fit outside of the second end portion **242** of the forearm tube **232**. A wrist rotating means **252** is provided at the joint formed between the forearm tube **232** and the wrist assembly **234** to provide rotational movement of the wrist assembly **234** relative to the forearm tube **232**.

It is to be understood that the articulated arm rotating means **244**, **246** and **252** are preferably rotatory actuators

which are commercially available components from Helac Corporation of Enumclaw, Wash. Preferably, the rotary actuators are hydraulically controlled. As shown in FIGS. 2 and 3, the rotary actuators 244, 246, and 252 preferably include direct mounted dual pilot check valves 254. A separate inlet hose and a separate outlet hose is connected to each rotatory actuator. For example, as shown in FIG. 2, the wrist rotary actuator 252 includes an inlet hose 252a and an outlet hose 252b and the forearm rotary actuator 246 includes an inlet hose 246a and an outlet hose 246b. As shown in FIG. 3, the elbow tube 230 and the forearm tube 232 include a side hose window 230a and 232a, respectively, to remove the hoses to the exterior of the articulated arm assembly 200.

Referring to FIGS. 2 and 3, the tee member 250 includes an interior bore (not shown). A nozzle assembly 260 is connected to the tee member 250. A swivel 262 is connected to the tee member 250 and in fluid engagement with the nozzle assembly 260. A fluid conduit 264 is connected to the swivel 262. The fluid conduit 264 is a flexible conduit, preferably a high pressure hose. A conduit bracket 266 is attached to a trolley side plate 210 to support the fluid conduit 264. Preferably, the fluid conduit 264 extends along the exterior of the beam assembly 52 and through the inlet opening 28 of the cyclone furnace 20. A high pressure fluid source 268 for introducing pressurized fluid, typically water, through the fluid conduit 264 and the nozzle assembly 260 is located exterior of the cyclone furnace 20.

In the preferred embodiment, the nozzle assembly 260 comprises a self-powered rotary nozzle having a rotary head with two ports. The furnace cleaning apparatus 50 will operate with a water pressure up to approximately 10,000 pounds per square inch and a flow rate of 80 gallons per minute.

The hydraulic hoses connected to the rotary actuators 244, 246, and 252 of the articulated arm assembly 200 preferably extend through the cyclone furnace 20 and exit the inlet opening 28 as partially shown in FIG. 1. The hydraulic hoses connected to the rotary actuator 122 and the drive source 218 of the beam assembly 52 similarly exit the cyclone furnace 20 at the inlet opening 28. A hydraulic power source 256 is positioned external of the cyclone furnace 20 and powers each of the rotary actuators via an external control panel 258. The external control panel controls the angular orientation of the beam assembly 52, the longitudinal positioning of the trolley 202 on the beam assembly 52, the configuration of the articulated arm assembly 200, and the direction of the nozzle assembly 260.

In the preferred embodiment of the present invention, the furnace cleaning apparatus 50 permits the cleaning of the interior of the cyclone furnace 20 in a variety of configurations and at any angle. This is illustrated by the dashed lines in FIG. 1 which show a few of the many possible configurations for cleaning the interior surface of the cyclone furnace 20. Obviously, the angle of the nozzle assembly 260 relative to the interior surface may also be manipulated to alter the angle at which the fluid jet attacks the interior surface of the cyclone furnace 20.

In the operation of the furnace cleaning apparatus 50, the operator may set the velocity of the trolley 202 along the beam assembly 52. This selection is totally independent of, and not correlated with, the oscillating movement of the trolley 202 and the beam assembly 52. The present invention offers the versatility of simultaneously permitting oscillating movement of the beam assembly 52, axial movement of the trolley 52 along the beam assembly 52, and reorientation of the articulated arm assembly 200 and nozzle assembly 260.

Preferably, the beam assembly 52 oscillates only through an angle of approximately 360° in one direction and then reverses and pivots through 360° in the other direction to minimize difficulties associated with the plurality of hoses wrapping around the beam assembly 52. It is to be understood that limit switches (not shown) may be provided with each of the rotary actuators and the drive source to limit the extent of the pivoting or oscillating movement. For example, it may be desirable to limit the oscillating movement of the beam assembly 52 to an arc of 60° in order to clean a desired portion of the cyclone furnace 20. In such a case, the limit switch restricts the rotation of the beam assembly back and forth through an arc of 60° .

Referring to FIG. 1, the articulated arm assembly 200 is illustrated in a position exterior of the cyclone furnace 20. As shown in FIG. 1, the beam assembly 52 extends beyond the outlet opening 32 of the second end wall 30 of the cyclone furnace 20. This enables the articulated arm assembly 200 to be positioned exterior of the second end wall 30 to clean the lower exterior portion thereof. The cyclone furnace 20 includes a lower opening 20a as shown in FIG. 1 to allow molten slag to escape during the combustion operations of the cyclone furnace 20. The liquid slag drains toward the opening 20a and discharges therethrough to a slag tank (not shown). Thus, to completely clean the cyclone furnace 20 it is necessary to clean the lower exterior portion of the second end wall 30 as shown in FIG. 1. The articulated arm assembly 200 has a length sufficient to allow it to reach the lower end of the cyclone furnace 20. The operator controls the configuration of the articulated arm assembly 200 and the orientation of the nozzle assembly 260 relative to the forearm tube 232 to direct the fluid spray in the desired direction. The cleaning of the second end wall 30 in a plane transverse to the articulated arm assembly 200 is accomplished by pivoting the beam assembly 52 from the control panel 258. It is important to understand that in the preferred embodiment of the present invention, the trolley 202 has no rotation relative to the beam assembly 52. Thus, as the beam assembly 52 pivots about its longitudinal axis, the trolley 202, the articulated arm assembly 200 and the nozzle assembly 260 also rotate.

The cleaning of the interior of the cyclone furnace 20 is accomplished by positioning the articulated arm assembly 200 in a generally horizontal position so as not to engage the outlet wall 36 of the outlet opening 32. The drive source 218 for the chain drive assembly 212 pulls the trolley 202 towards the rear of the beam assembly 52. During the positioning of the trolley 202 and the articulated arm assembly 200 fully within the cyclone furnace 20, the beam assembly 52 is in the angular orientation as shown in FIG. 1 so as to allow the trolley 202 to pass by the intermediate hanger assembly 130. Once the trolley 202 has fully passed beyond the intermediate hanger assembly 130, the interior cleaning of the cyclone furnace may commence.

It is anticipated that in normal cleaning operations, the articulated arm assembly 200 and the direction of the nozzle assembly 260 will be oriented for the particular area to be cleaned, and the beam assembly 52 will slowly pivot through approximately one revolution before reversing direction and pivoting back to the original position. The nozzle orientation in the articulated arm configuration can be altered at any time during the cleaning operation. The primary concern during the cleaning operations within the cyclone furnace 20 is to avoid contacting the articulated arm assembly 200 and the nozzle assembly 260 with the clamp 78 and the intermediate hanger assembly 130.

Additionally, cleaning operations can be performed by limiting the amount of oscillation of the beam assembly 52

prior to reversing its direction. This enables the operator to concentrate his cleaning operations over a certain specified area of the cyclone furnace **20**. In yet another cleaning situation, it may be desirable to maintain the angular orientation of the beam assembly **52** while moving the trolley **202** along the beam assembly **52**. The beam assembly **52** could thus be rotated slightly to clean an adjacent area along the length of the cyclone furnace **20**. Additionally, the nozzle assembly **260** may be independently pivoted while the beam assembly **52** oscillates. Thus, the furnace cleaning apparatus **50** of the present invention provides the operator with a variety of cleaning operations which can be used to clean the cyclone furnace **20** depending on the specific circumstances and requirements.

The foregoing disclosure and description of the invention is illustrative and explanatory thereof, and various changes in the size, shape, and materials, as well as in the details of illustrative construction and assembly, may be made without departing from the spirit of the invention.

What is claimed is:

1. An apparatus for cleaning a cyclone furnace with a fluid from a fluid source, the cyclone furnace including a sidewall, a first end wall having an inlet opening, a second end wall having an outlet opening with the outlet opening defined by an outlet wall extending inwardly from the second end wall, the apparatus comprising:

- a beam assembly capable of being pivotably mounted to the cyclone furnace;
- means for oscillating said beam assembly;
- a trolley movably mounted to said beam assembly;
- means for moving said trolley relative to said beam assembly;
- an articulated arm assembly mounted to said trolley;
- means for pivoting said articulated arm assembly relative to said trolley;
- nozzle means connected to said articulated arm assembly;
- and
- fluid conduit means for conducting fluid from the fluid source to the cyclone furnace, said fluid conduit means is connected to said nozzle means.

2. The apparatus of claim **1**, wherein said beam assembly extends from the inlet opening to the outlet opening.

3. The apparatus of claim **1**, further comprising intermediate beam support means for supporting said beam assembly in the interior of the cyclone furnace.

4. The apparatus of claim **3**, wherein said intermediate beam support means comprises:

- a clamp member capable of attaching to the outlet wall;
- a rotational bearing assembly mounted to said beam assembly; and
- an intermediate hanger assembly having a first end and a second end, said first end attaching to said clamp member and said second end attaching to said rotational bearing assembly.

5. The apparatus of claim **1**, wherein said beam assembly has a longitudinal axis and said trolley is capable of moving along said longitudinal axis of said beam assembly.

6. The apparatus of claim **1**, wherein said articulated arm assembly comprises:

- a plurality of arm members pivotably connected to one another; and
- second means for pivoting said plurality of arm members relative to one another.

7. The apparatus of claim **6**, wherein said second pivoting means comprises independently controlled pivoting means for independently pivoting each said arm member.

8. The apparatus of claim **7**, wherein said articulated arm assembly comprises:

- a forearm member having a first end and a second end, said first end of said forearm member is connected to said trolley;
- an elbow member having a first end and a second end, said first end of said elbow member is connected to said second end of said forearm member; and
- a wrist member having a first end and a second end, said first end of said wrist member is connected to said second end of said elbow member and said second end of said wrist member is connected to said nozzle means.

9. The apparatus of claim **1**, wherein said articulated arm assembly pivoting means is capable of independently adjusting the direction of the emitted fluid spray.

10. An apparatus for cleaning a cyclone furnace with a fluid from a fluid source, the apparatus comprising:

- a beam assembly capable of being pivotably mounted to the cyclone furnace, said beam assembly extending substantially through the cyclone furnace;
- means for oscillating said beam assembly;
- a trolley movably mounted to said beam assembly;
- means for moving said trolley relative to said beam assembly;
- an articulated arm assembly mounted to said trolley;
- means for pivoting said articulated arm assembly relative to said trolley;
- nozzle means connected to said articulated arm assembly;
- and
- fluid conduit means for conducting fluid from the fluid source to the cyclone furnace, said fluid conduit means is connected to said nozzle means.

11. The apparatus of claim **10**, further comprising intermediate beam support means for supporting said beam assembly in the interior of the cyclone furnace.

12. The apparatus of claim **11**, wherein said intermediate beam support means comprises:

- a clamp member capable of attaching to the cyclone furnace;
- a rotational bearing assembly mounted to said beam assembly; and
- an intermediate hanger assembly having a first end and a second end, said first end attaching to said clamp member and said second end attaching to said rotational bearing assembly.

13. The apparatus of claim **10**, wherein said beam assembly has a longitudinal axis and said trolley is capable of moving along said longitudinal axis of said beam assembly.

14. The apparatus of claim **10**, wherein said articulated arm assembly comprises:

- a plurality of arm members pivotably connected to one another; and
- second means for pivoting said plurality of arm members relative to one another.

15. The apparatus of claim **14**, wherein said second pivoting means comprises independently controlled pivoting means for independently pivoting each said arm member.

16. The apparatus of claim **15**, wherein said articulated arm assembly comprises:

- a forearm member having a first end and a second end, said first end of said forearm member is connected to said trolley;
- an elbow member having a first end and a second end, said first end of said elbow member is connected to said second end of said forearm member; and

11

a wrist member having a first end and a second end, said first end of said wrist member is connected to said second end of said elbow member and said second end of said wrist member is connected to said nozzle means.

17. The apparatus of claim 10, wherein said articulated arm assembly pivoting means is capable of independently adjusting the direction of the emitted fluid spray.

18. *An apparatus for cleaning a housing with a fluid from a fluid source, the apparatus comprising:*

a beam assembly capable of being pivotably mounted to the housing, said beam assembly extending substantially through the housing;

means for oscillating said beam assembly;

a trolley movably mounted to said beam assembly;

means for moving said trolley relative to said beam assembly;

an arm assembly mounted to said trolley;

means for pivoting said arm assembly relative to said trolley;

nozzle means connected to said arm assembly; and

fluid conduit means for conducting fluid from the fluid source to the housing, said fluid conduit means is connected to said nozzle means.

19. The apparatus of claim 18, further comprising intermediate beam support means for supporting said beam assembly in the interior of the housing.

20. The apparatus of claim 19, wherein said intermediate beam support means comprises:

a clamp member capable of attaching to the housing;

a rotational bearing assembly mounted to said beam assembly; and

an intermediate hanger assembly having a first end and a second end, said first end attaching to said clamp member and said second end attaching to said rotational bearing assembly.

21. The apparatus of claim 18, wherein said beam assembly has a longitudinal axis and said trolley is capable of moving along said longitudinal axis of said beam assembly.

22. The apparatus of claim 18, wherein said arm assembly comprises:

a plurality of arm members pivotably connected to one another; and

second means for pivoting said plurality of arm members relative to one another.

23. The apparatus of claim 22, wherein said second pivoting means comprises independently controlled pivoting means for independently pivoting each said arm member.

24. The apparatus of claim 23, wherein said arm assembly comprises:

12

a forearm member having a first end and a second end, said first end of said forearm member is connected to said trolley;

an elbow member having a first end and a second end, said first end of said elbow member is connected to said second end of said forearm member; and

a wrist member having a first end and a second end, said first end of said wrist member is connected to said second end of said elbow member and said second end of said wrist member is connected to said nozzle means.

25. The apparatus of claim 18, wherein said arm assembly pivoting means is capable of independently adjusting the direction of the emitted fluid spray.

26. A method for cleaning the interior of a housing with a fluid from a fluid source using a beam assembly having a longitudinal axis which supports a trolley, an arm assembly pivotally attached to the trolley, and a nozzle connected to the arm assembly, the method comprising the steps of:

inserting the beam assembly into the housing;

supporting the beam assembly within the housing;

spraying fluid from the fluid source through the nozzle onto the interior surface of the housing; and

oscillating the beam assembly along its longitudinal axis thereby moving the nozzle in a plane substantially perpendicular to the longitudinally axis of the beam assembly.

27. The method of claim 26 further comprising the step of displacing the trolley along the longitudinal axis of the beam assembly.

28. The method of claim 26 further comprising the step of pivoting the arm assembly about the trolley in a plane substantially parallel with the longitudinally axis of the beam assembly.

29. A method for cleaning the interior of a housing with a fluid from a fluid source using a beam assembly having a longitudinal axis which supports a trolley, an arm assembly pivotally attached to the trolley, and a nozzle connected to the arm assembly, the method comprising the steps of:

inserting the beam assembly into the housing;

supporting the beam assembly within the housing;

spraying fluid from the fluid source through the nozzle onto the interior surface of the housing;

oscillating the beam assembly along its longitudinal axis thereby moving the nozzle in a plane perpendicular to the longitudinally axis of the beam assembly;

displacing the trolley along the longitudinal axis of the beam assembly; and

pivoting the arm assembly about the trolley in a plane substantially parallel with the longitudinal axis of the beam assembly.

* * * * *