



US00RE36269E

United States Patent [19] Wright

[11] E

Patent Number: **Re. 36,269**

[45] Reissued Date of Patent: ***Aug. 17, 1999**

[54] SAW BLADE RETENTION SYSTEM

FOREIGN PATENT DOCUMENTS

[75] Inventor: **David W. Wright**, Ken Caryl, Colo.

41020211 12/1991 Germany .

[73] Assignee: **Minnesota Mining And Manufacturing Company**, St. Paul, Minn.

OTHER PUBLICATIONS

[*] Notice: This patent is subject to a terminal disclaimer.

Brochure entitled "Sars-Sternal Saw System-Operators manual" of Sarns 3M Health Care, Dec. 1989.

Brochure entitled "Sarns Auxiliary Cardiovascular Equipment" of Sarns 3M Healthcare, 1989.

Flyer entitled "Cleaning the Sarns Sternal Saw/Limpieza de la Sierra Sarns Sternal" of Sarns, Form No. 16087100, 1993.

Brochure entitled "The Hall Thoracic Surgery System" by Zimmer-Hall Surgical, Carpinteria, CA. (Lit. No. 97-5059-001), 1991.

Brochure entitled "The Hall Blade and Bur Book" by Zimmer-Hall Surgical, Carpinteria, CA. (Lit. No. 9703000-320-REV.3), 1992.

Stryker Brochure entitled "Stryker Instruments-The Powerful Choice-Battery or Electric-The Stryker Sternotomy Powered Instrument Systems" (1000-168REV-Dec. 1992).

Sheet entitled "Cast Cutter" by American Orthopaedic, DeSoto, Kan.

Sheet entitled "The Stryker Cast Room System".

Sheet entitled "Stryker Cast Cutter-The first and lasting value".

[21] Appl. No.: **08/897,018**

[22] Filed: **Jul. 18, 1997**

Related U.S. Patent Documents

Reissue of:

[64] Patent No.: **5,433,457**

Issued: **Jul. 18, 1995**

Appl. No.: **08/218,345**

Filed: **Mar. 25, 1994 U.S. Applications:**

[63] Continuation-in-part of application No. 08/006,814, Jan. 21, 1993, Pat. No. 5,340,129.

[51] Int. Cl.⁶ **B26D 1/08; B27B 19/09**

[52] U.S. Cl. **279/90; 30/337; 30/351; 30/392; 83/699.21; 606/82; 606/177**

[58] Field of Search **279/89-91; 30/337-339; 30/351, 392-394; 606/82, 177; 83/699.21**

Primary Examiner—**Steven C. Bishop**

Attorney, Agent, or Firm—**Gary L. Griswold; Robert W. Sprague; Stephen W. Bauer**

[57] ABSTRACT

A saw blade retention system for retaining a saw blade to a reciprocating saw includes a shaft connected to the saw for reciprocation and having a slot for receiving the saw blade. The saw blade retention system also includes a chuck disposed about the shaft and having a slot aligned with the slot in the shaft in an unlocked position for allowing the saw blade to be disposed in the slot for the shaft. The saw blade retention system further includes a cam-type mechanism for allowing the chuck to rotate angularly relative to the saw blade and shaft to a locked position to prevent the saw blade from exiting the slots and for allowing the chuck to move axially relative to the shaft to prevent axial movement of the saw blade between the chuck and the shaft. Complementary inclined surfaces are provided on the blade and the chuck to center the blade relative to its intended path of reciprocation.

[56] References Cited

U.S. PATENT DOCUMENTS

2,282,902	5/1942	Sultan	145/108
2,408,567	10/1946	Mauch	279/93
2,703,716	3/1955	Shore	279/93
3,927,893	12/1975	Dillon et al.	279/75
3,943,934	3/1976	Bent	128/317
3,964,163	6/1976	Russo	30/166 R
4,020,555	5/1977	Hedrick	30/392
4,036,236	7/1977	Rhodes, Jr.	128/317
4,386,609	6/1983	Mongeon	128/317
4,528,753	7/1985	Kuhlmann et al.	30/392
4,626,146	12/1986	Neumaier	408/239
4,691,929	9/1987	Neumaier et al.	279/19.3
4,872,452	10/1989	Alexson	128/92
5,306,025	4/1994	Langhoff	279/90
5,340,129	8/1994	Wright	279/90

56 Claims, 4 Drawing Sheets

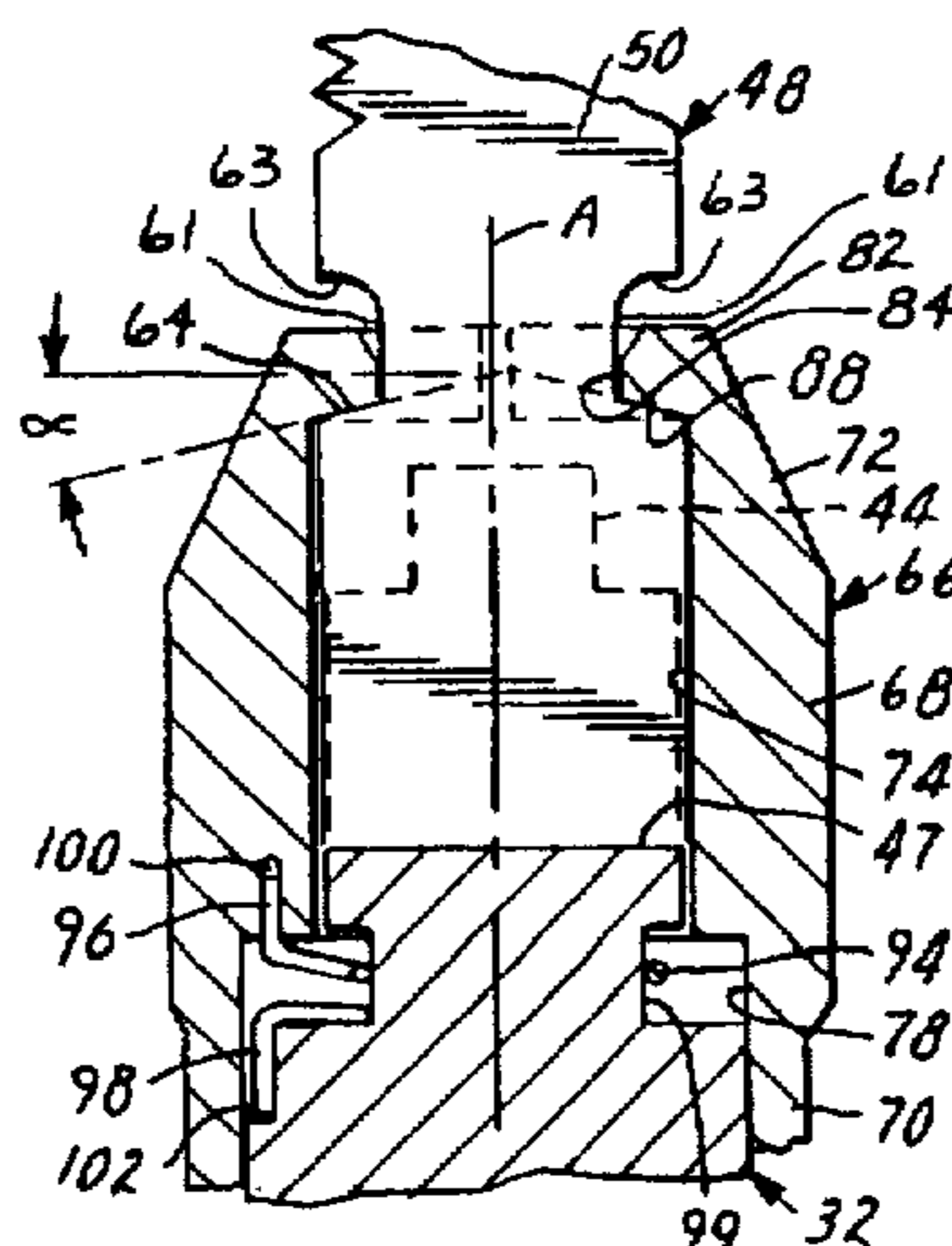

FIG. 1

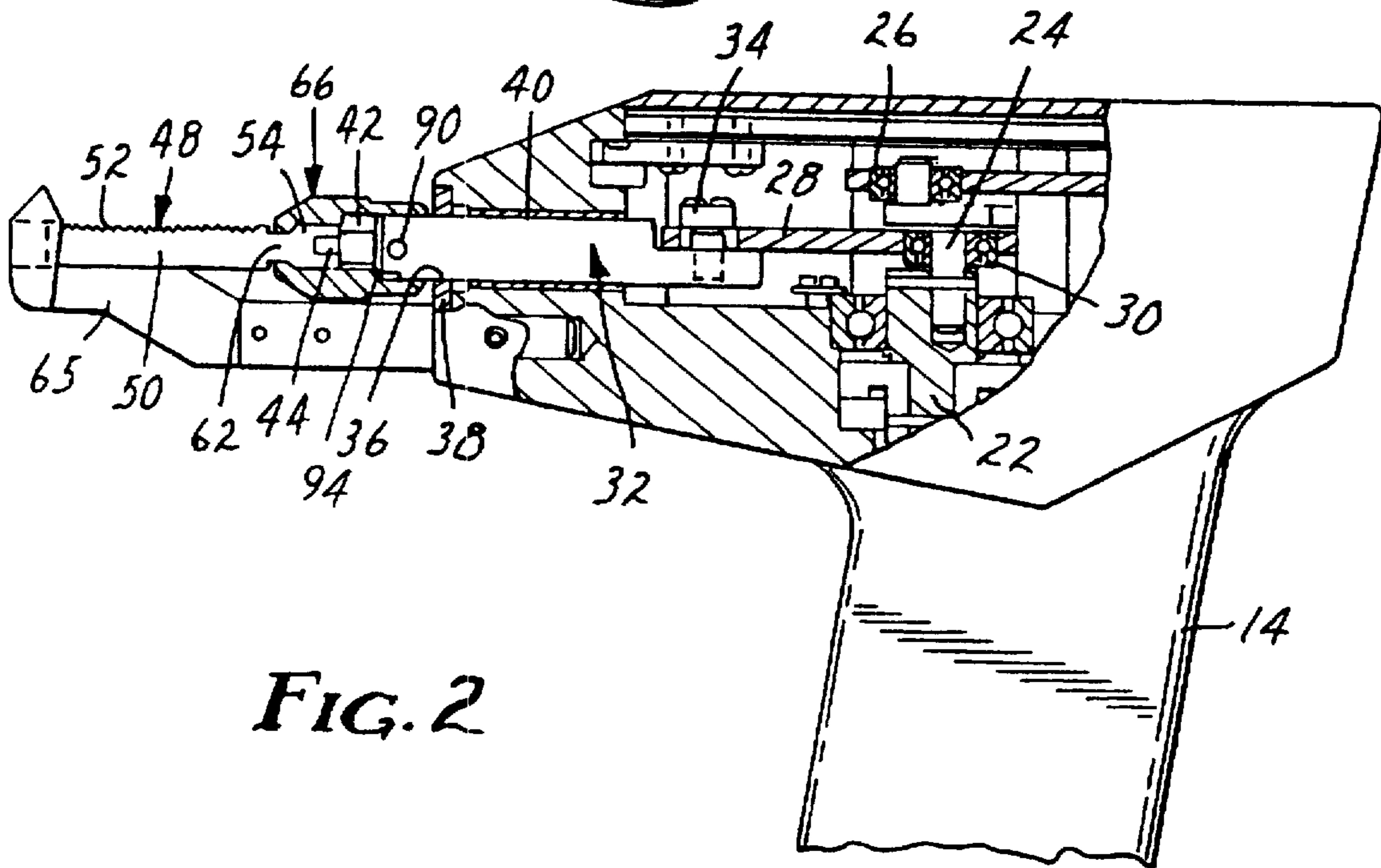
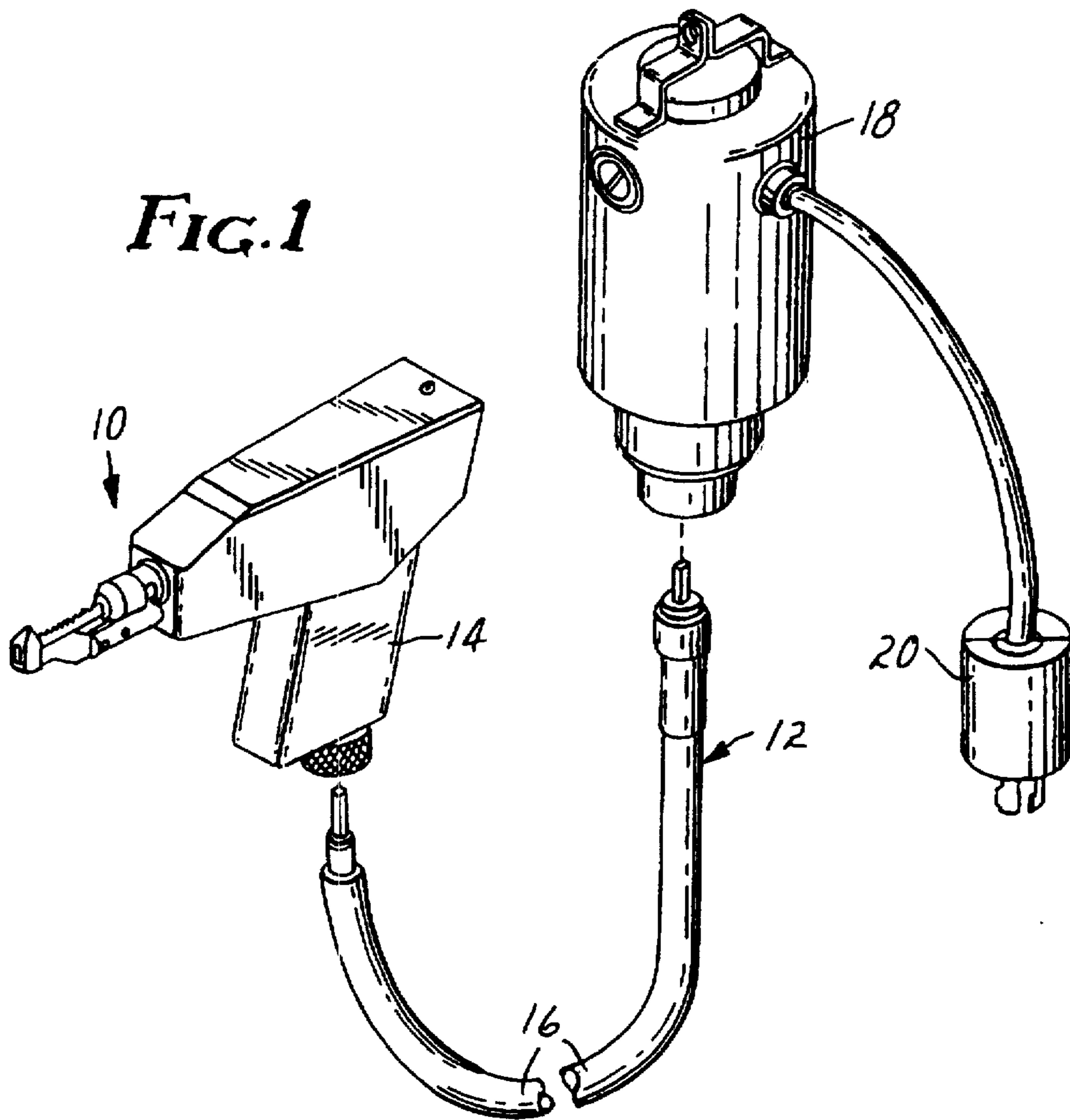

FIG. 2

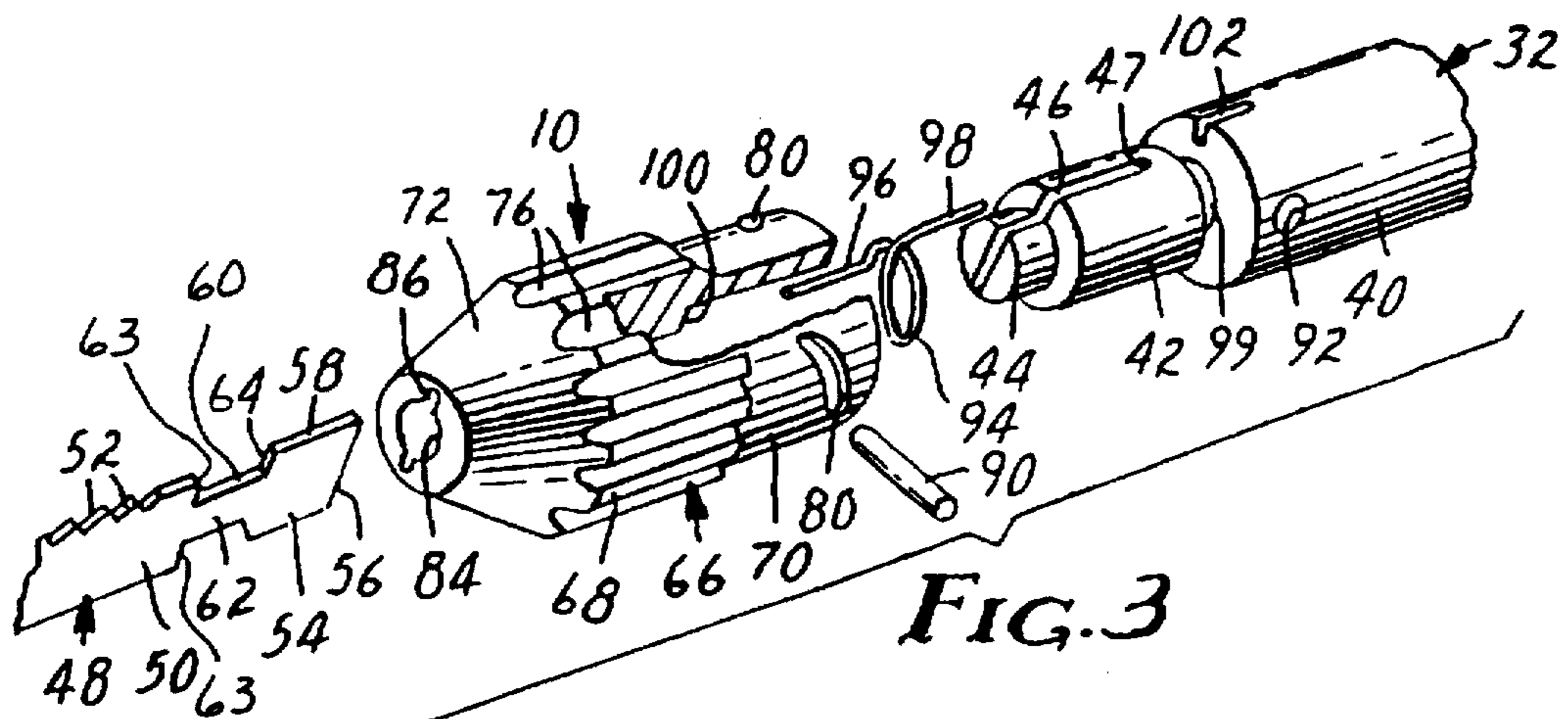

FIG. 3

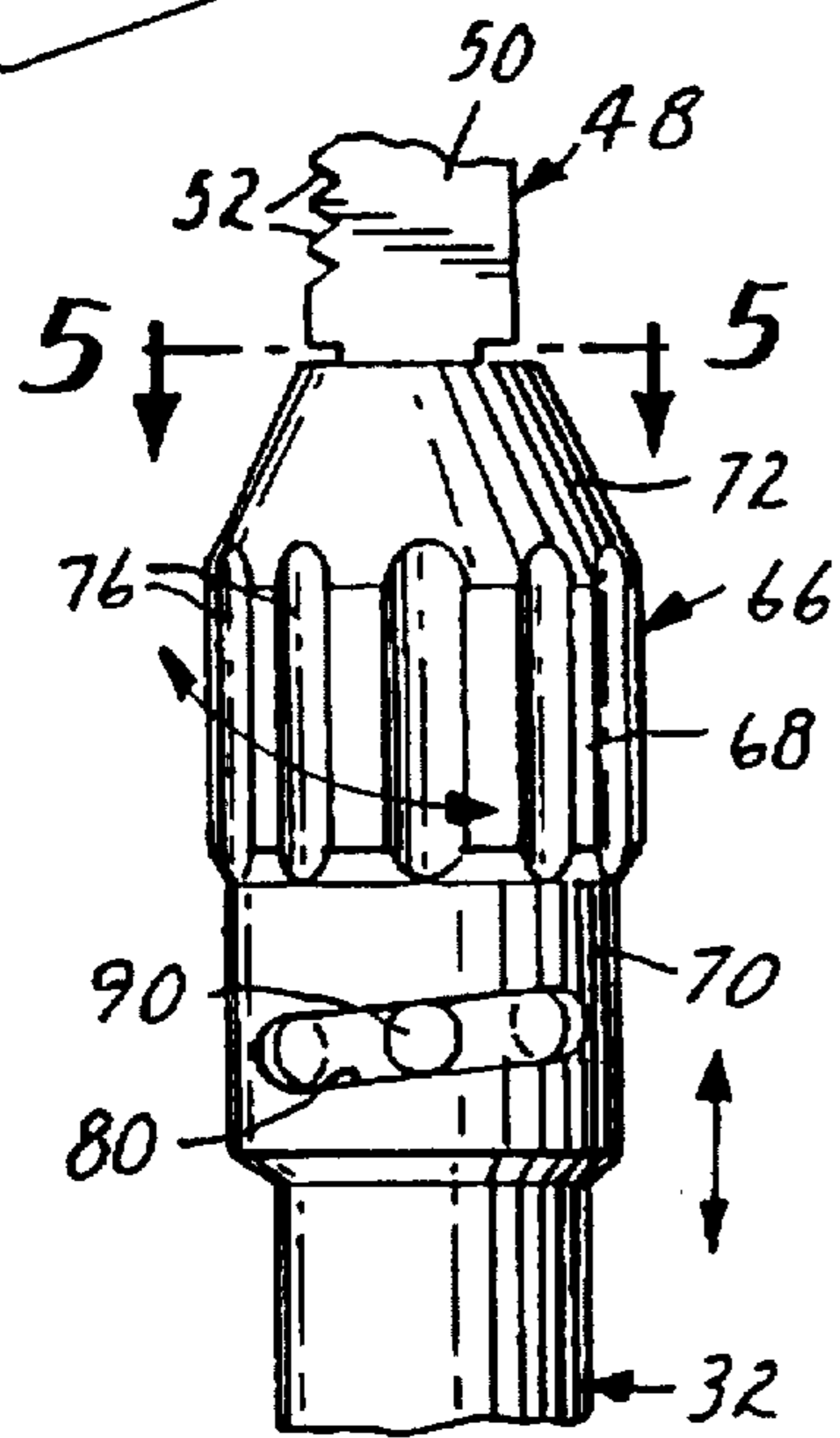

FIG. 4

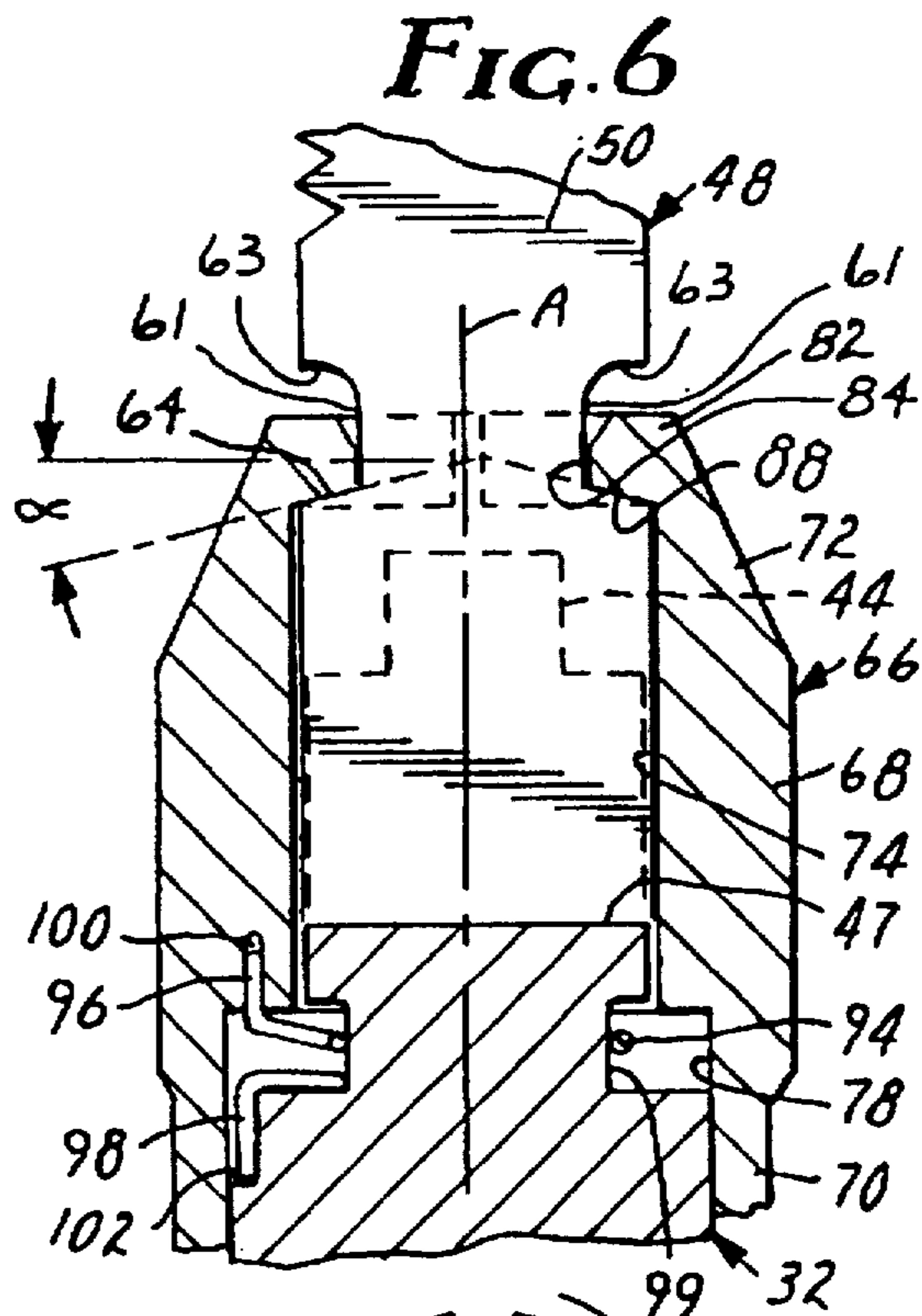

FIG. 6

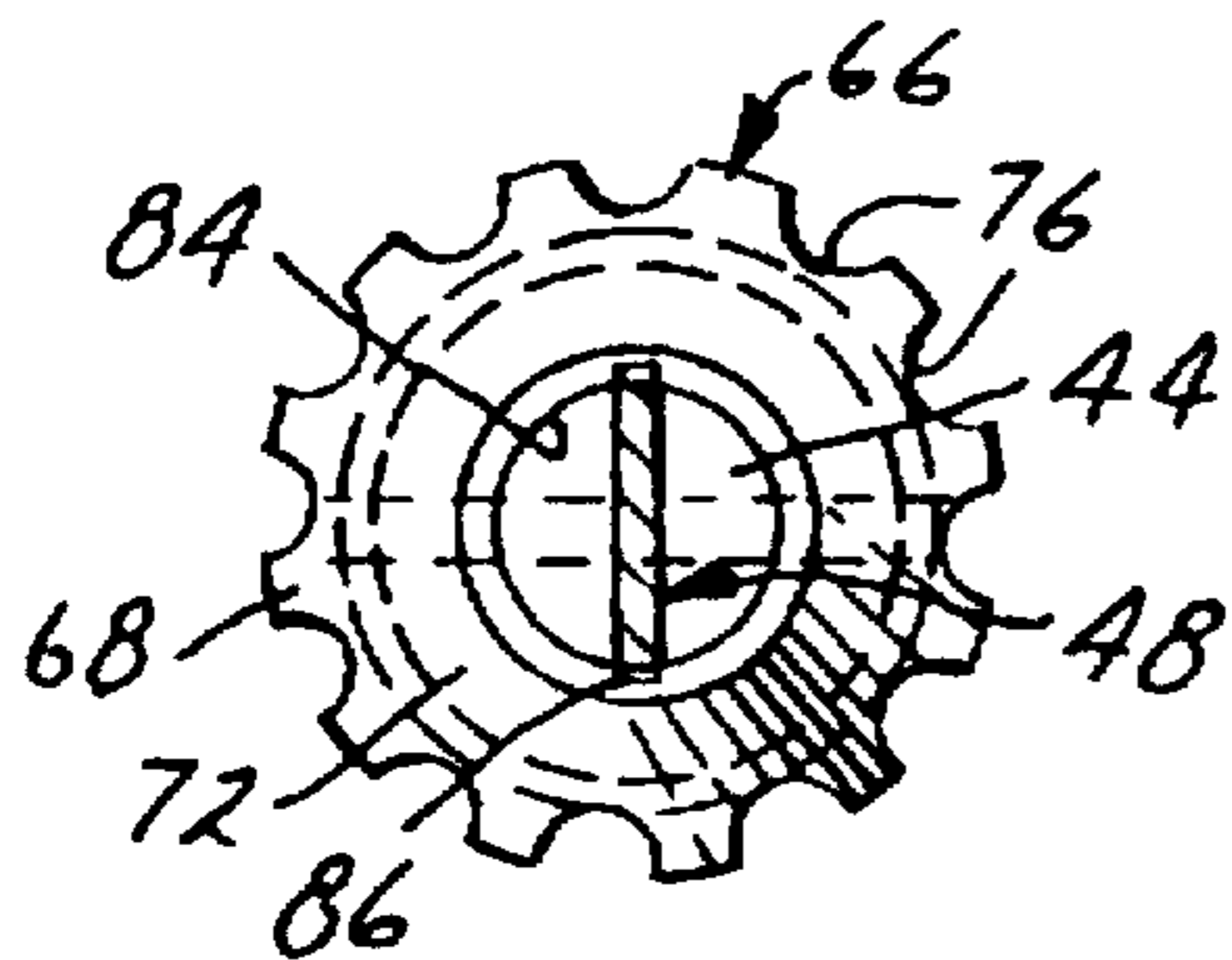

FIG. 5A

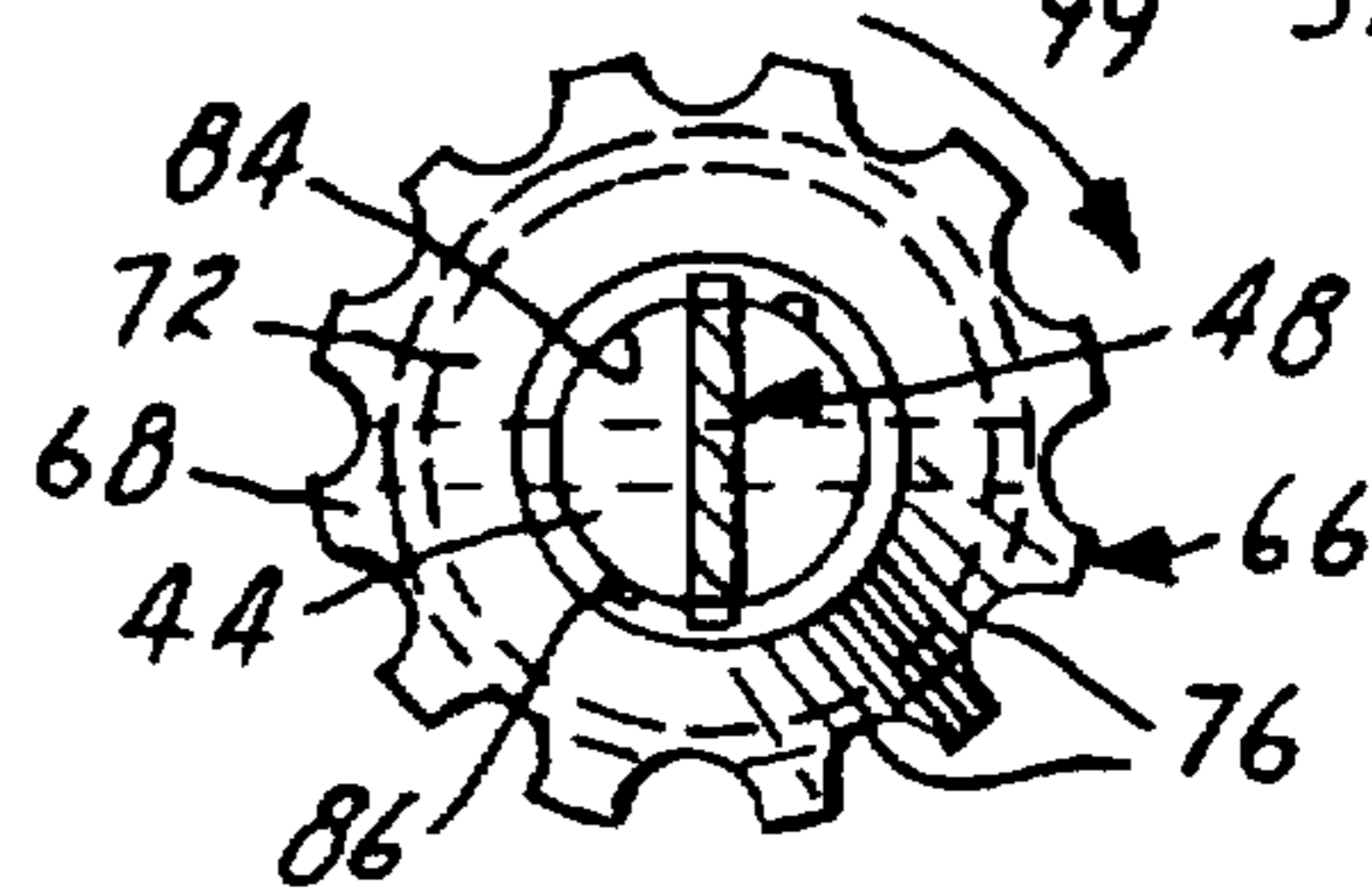

FIG. 5B

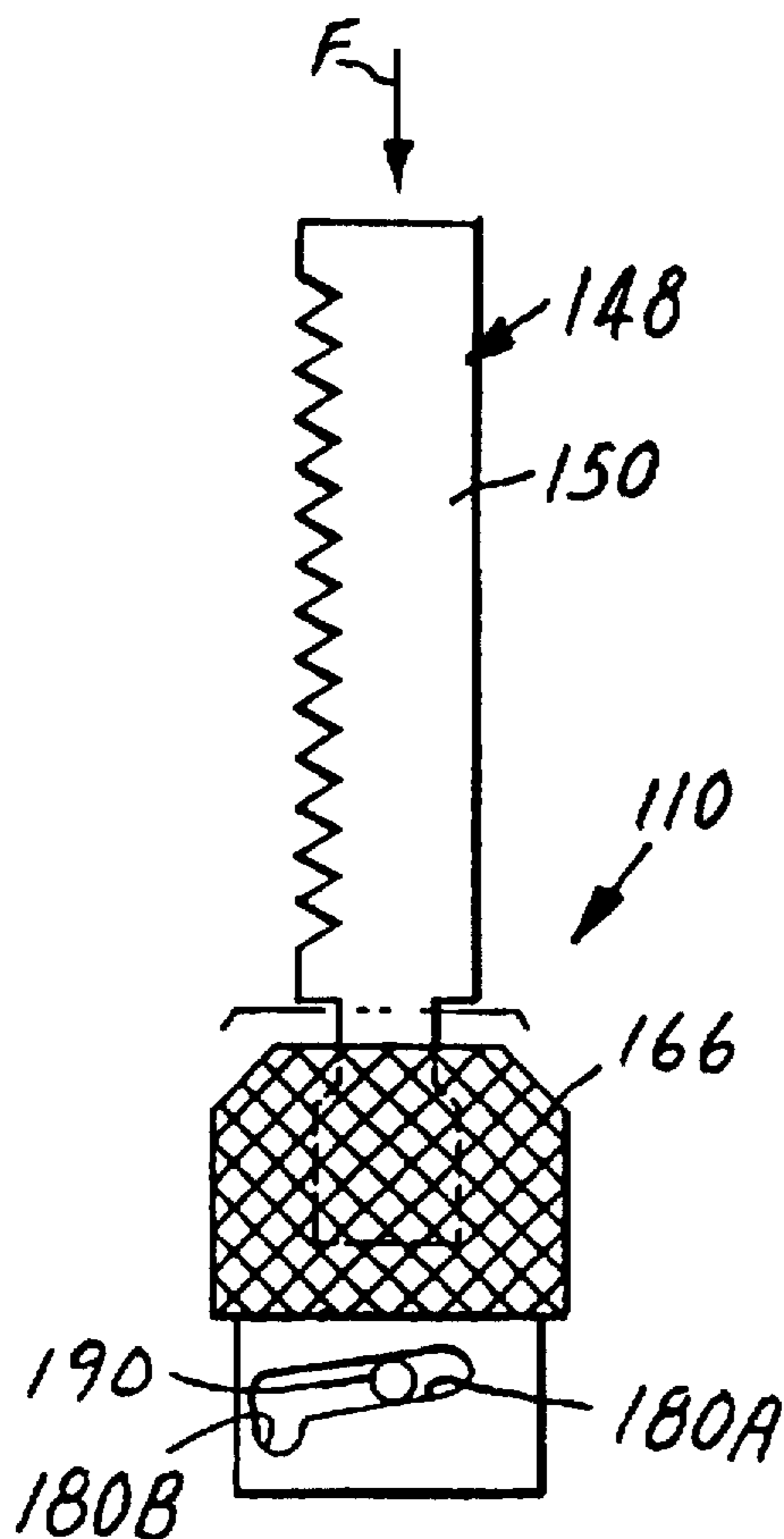

FIG. 8

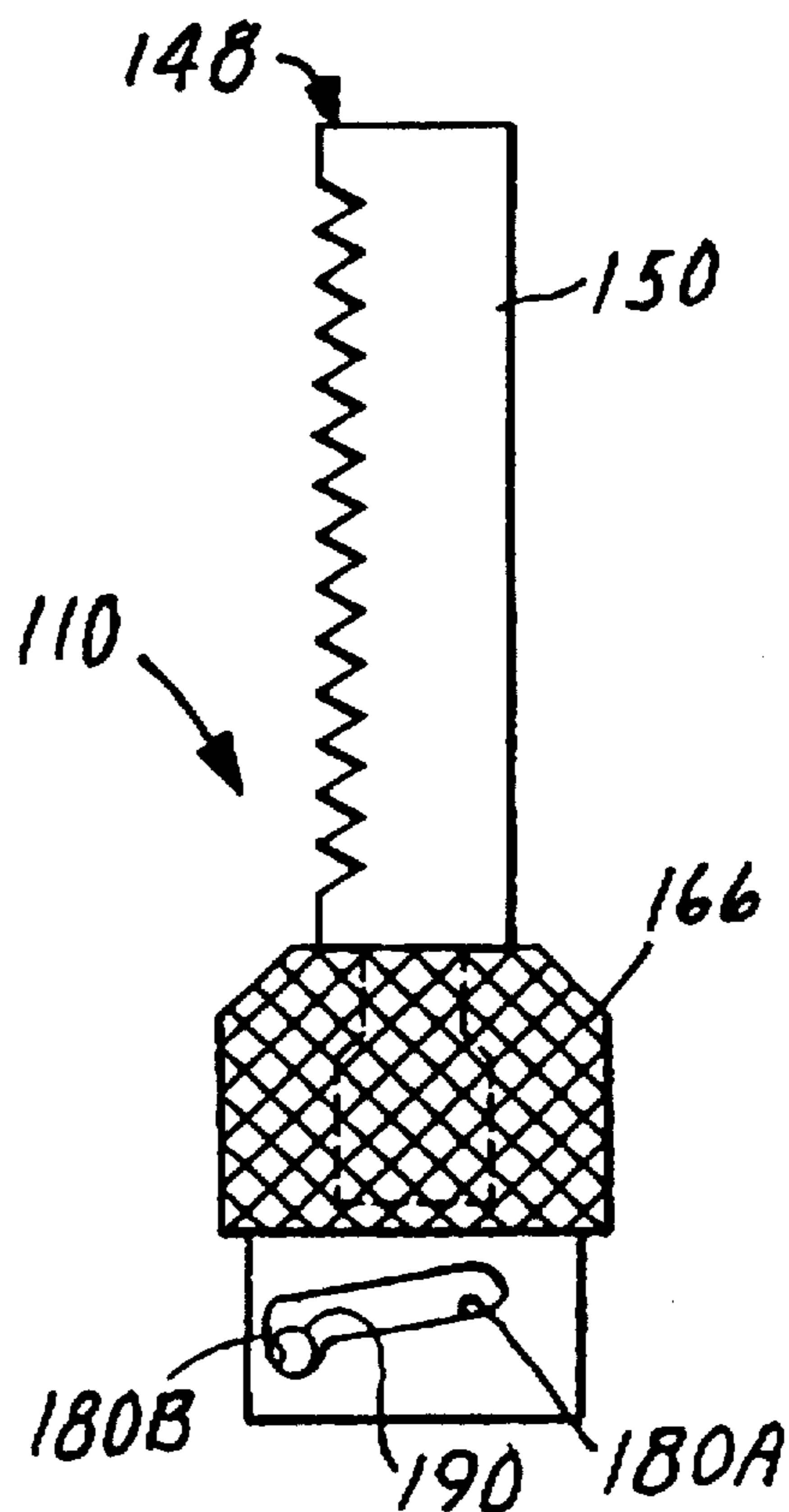

FIG. 7

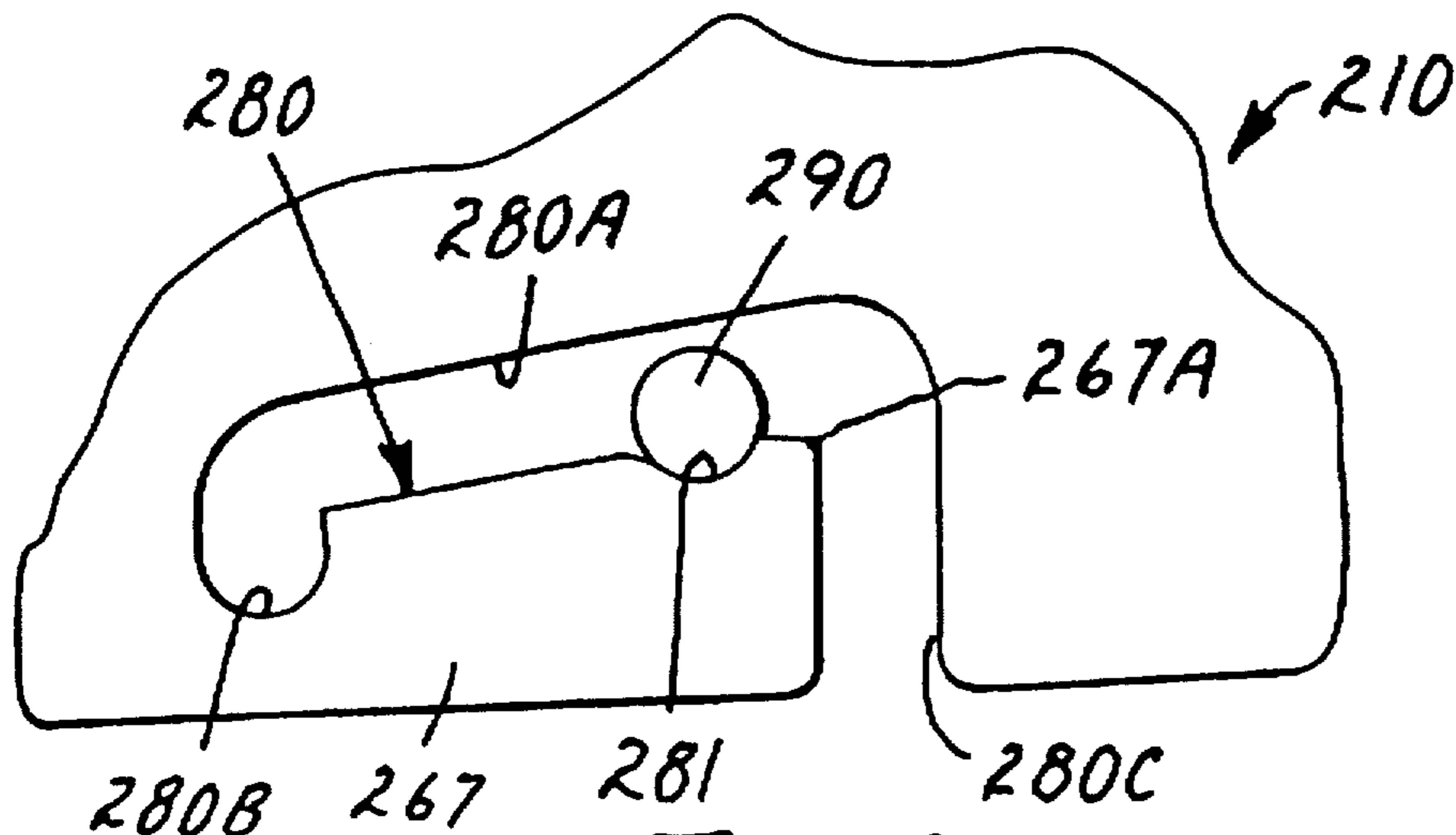
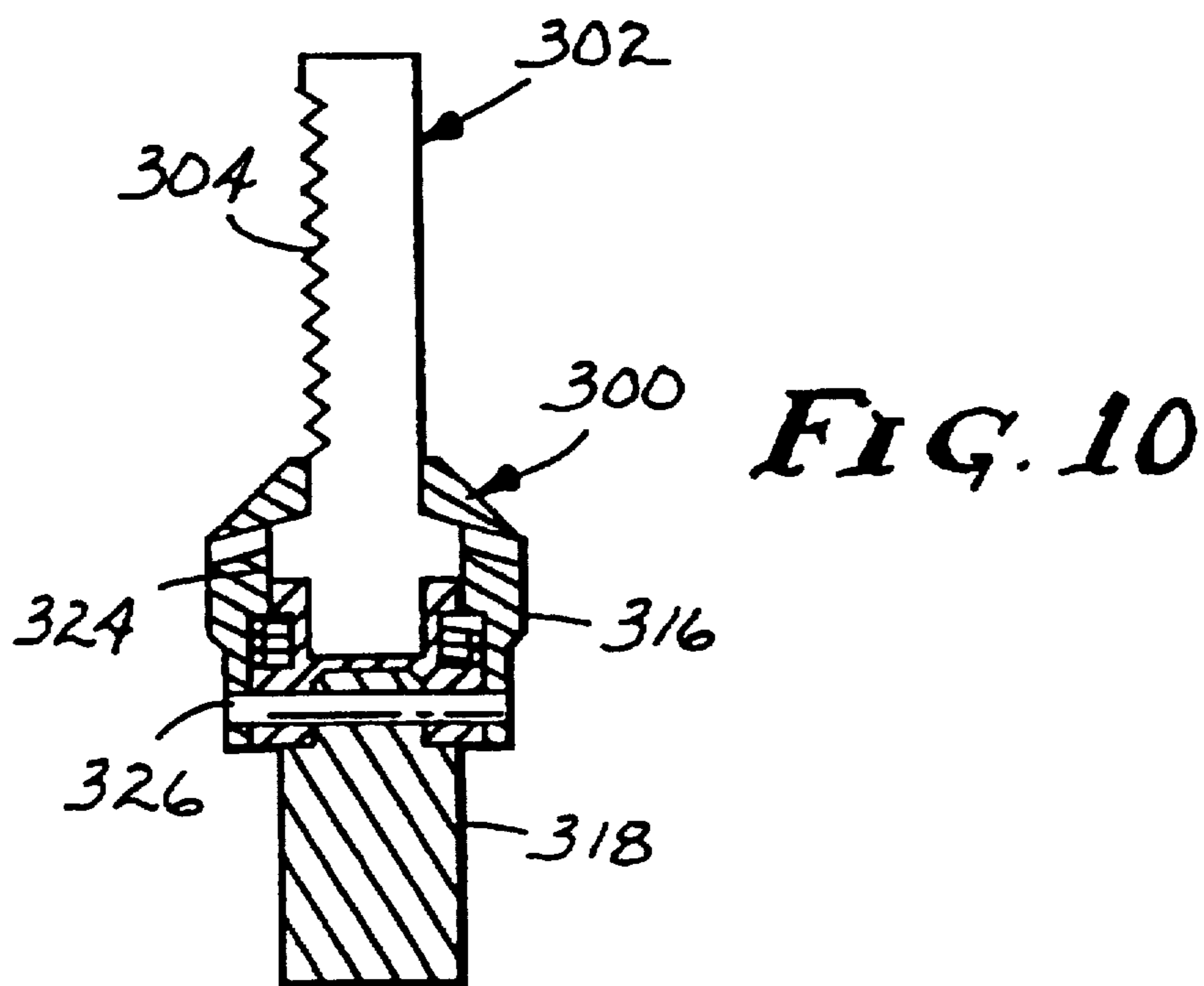
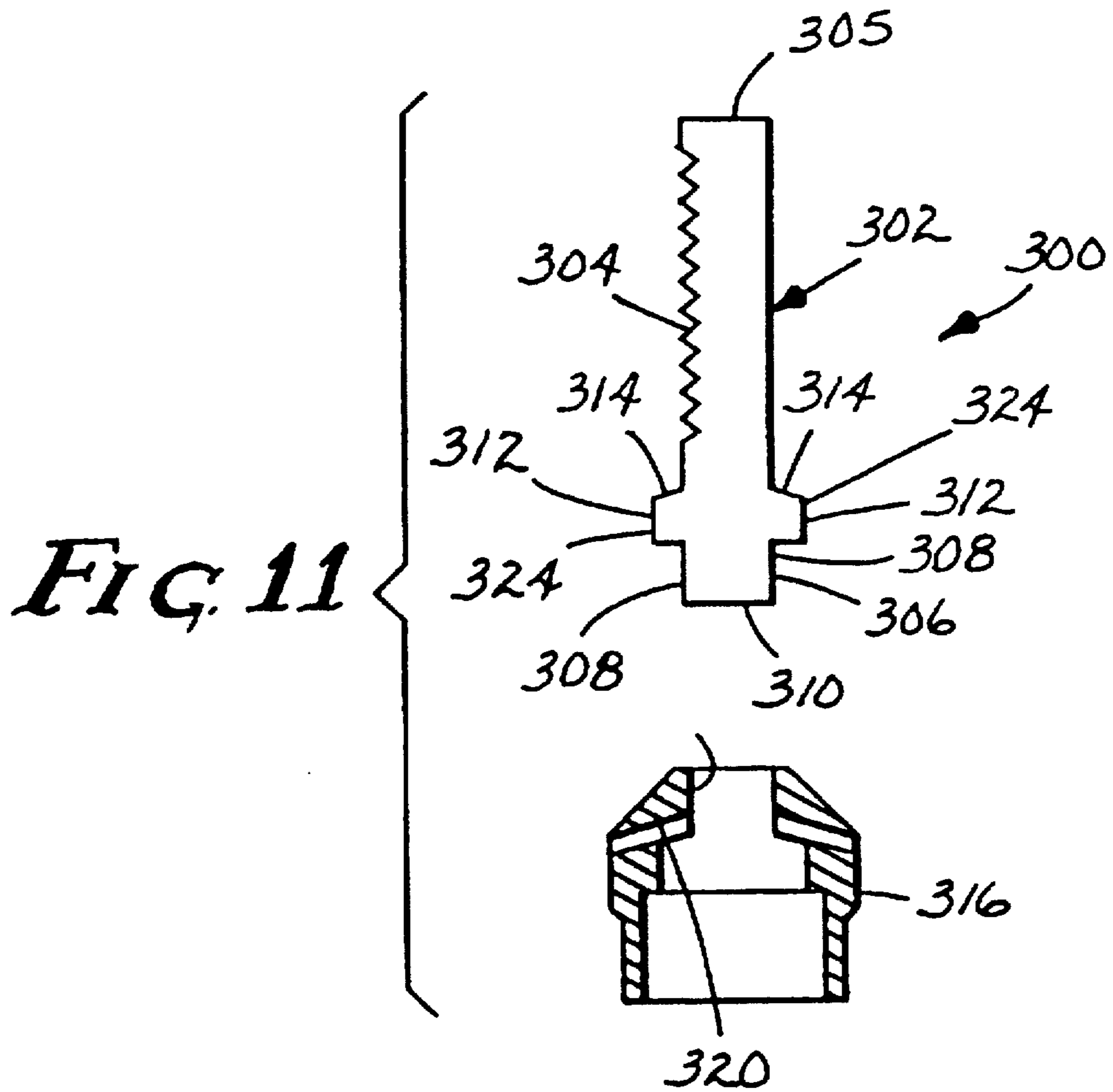

FIG. 9



SAW BLADE RETENTION SYSTEM

Matter enclosed in heavy brackets [] appears in the original patent but forms no part of this reissue specification; matter printed in italics indicates the additions made by reissue.

This application is a continuation-in-part of U.S. patent application Ser. No. 08/006,814, filed Jan. 21, 1993, now U.S. Pat. No. 5,340,129.

BACKGROUND OF THE INVENTION

1. Field of the Invention

The present invention relates generally to saws and, more particularly, to a saw blade retention system for a reciprocating surgical saw.

2. Description of the Related Art

Generally, a reciprocating saw known as a "sternal saw" is used in splitting a sternum of a patient during thoracic surgery by cutting from either the suprasternal notch or the xiphoid process. Typically, the sternal saw is driven through a flexible drive shaft by an electric motor which may be operated by a foot control. The sternal saw includes a reciprocating shaft and saw blade. The saw blade is removably secured to the reciprocating shaft by a fastener such as a screw.

One disadvantage of the above sternal saw is that the saw blade may rotate about the screw relative to the reciprocating shaft. Another disadvantage is that it is not convenient to change the saw blade after sterilization of the sternal saw. Yet another disadvantage is that a tool such as a screwdriver is required to change the saw blade. Still another disadvantage is that the saw blade and screw are packaged together which is undesired. A further disadvantage is that the screw increases the cost for changing or replacing the saw blade.

One sternal saw that has been in wide use has been sold by Minnesota Mining and Manufacturing Company, St. Paul, Minn., under the trade designation "SARNS" Sternal Saw, Catalog No. 6090.

SUMMARY OF THE INVENTION

This invention provides a saw blade and a saw blade retention system that are adapted to facilitate aligning a saw blade relative to a reciprocating or orbital saw, and that are adapted to securely retain the saw blade on the saw. In the case of the reciprocating saw, the saw blade and saw blade retention system are designed to bring the longitudinal axis of an elongate saw blade into alignment with the intended path of travel of the saw blade.

Generally, a saw blade of the invention comprises a generally elongate blade portion having a plurality of teeth, and a shank portion extending from the blade portion for connection to a reciprocating saw. The saw blade has a longitudinal axis extending through the blade and shank portions. The shank portion is generally planar having opposite major surfaces, opposite lateral edges, and a generally linear or planar end edge extending generally perpendicular to the longitudinal axis of the saw blade. Each of the opposite lateral edges of the shank portion includes at least one inclined edge between the end edge and the blade portion, with the inclined edge generally facing away from the end edge and extending at an inclined angle relative to the longitudinal axis of the saw blade. The inclined orientation of the inclined edges relative to the end edge tends to facilitate alignment of the saw blade relative to a saw.

Preferably, a pair of recesses are provided in the shank portion, with the recesses extending generally laterally

inwardly toward one another from the opposite lateral edges of the shank portion. The inclined edges are formed along one edge of each recess.

Preferably, the inclined edges extend at an angle of about 110 degrees relative to the longitudinal axis of the saw blade. Also, preferably, the inclined edges are disposed at an angle of about twenty degrees relative to the end edge, and an angle of about 140 degrees relative to one another.

In a second aspect of the invention, a saw blade retention system is provided for a reciprocating saw. The saw blade retention system comprises a surgical saw blade as described above, and a reciprocating saw. The saw comprises a shaft mounted in the saw for reciprocation. The shaft has a first blade-receiving slot at one end of the shaft for receiving the shank portion of the saw blade, with the first blade-receiving slot having a bottom end and an open end. A chuck is disposed about the shaft. The chuck has an annular ledge extending radially inwardly at one end to define a blade-receiving opening, with a second blade-receiving slot extending through the ledge generally radially outwardly from the opening. The chuck is mounted on the saw for rotation relative to the shaft between an unlocked position and a locked position. In the unlocked position, the second blade-receiving slot in the chuck is aligned with the first blade-receiving slot in the shaft to allow the saw blade to be inserted into the first and second blade-receiving slots. In the locked position, the first and second blade-receiving slots are not aligned such that the ledge of the chuck holds the saw blade in the first blade-receiving slot. The ledge of the chuck has a generally frustoconical surface generally complementary to the inclined edges of the saw blade for engagement with the inclined edges of the saw blade when the chuck is moved to its locked position such that the end edge of the saw blade is held against the bottom of the first blade-receiving slot and the saw blade tends to be centered by the forces applied by the frustoconical surface and the bottom of the first blade-receiving slot.

Preferably, the blade-receiving opening of the chuck has a diameter at least as large as the distance between the opposing recesses of the saw blade but less than the distance between the lateral edges of the shank portion of the saw blade.

Also, preferably, cam slots are provided in one of the chuck and shaft, and a pin is mounted on the other of the chuck and shaft, with the pin extending into the cam slots. The cam slots are disposed at a helical angle relative to the axis of rotation of the chuck such that the frustoconical surface of the ledge moves closer to the bottom of the first blade-receiving slot as the chuck is rotated from its unlocked position toward its locked position.

Most preferably, the inclined edges of the saw blade are disposed at an angle of approximately 20 degrees relative to the end edge of the saw blade; the frustoconical surface of the chuck is disposed at an angle of approximately 20 degrees relative to the bottom of the first blade-receiving slot; and the helical angle of the cam slots is approximately eight degrees.

Also, preferably, a biasing means is provided for biasing the chuck toward its locked position. For example, the biasing means may comprise a torsion spring operatively linked with the chuck and shaft to bias the chuck toward its locked position relative to the shaft.

According to one preferred aspect of the invention, a detent means is provided for releasably securing the chuck in its unlocked position to facilitate inserting the saw blade.

One advantage of the present invention is that a saw blade retention system is provided for removably retaining a saw

blade to a reciprocating or sternal saw. Another advantage of the present invention is that the saw blade retention system incorporates a self-centering blade feature which provides axial and radial locking action by a three point pinch, trapping the saw blade to prevent movement thereof. Yet another advantage of the present invention is that the saw blade retention system eliminates the use of screws and screwdrivers. A further advantage of the present invention is that the saw blade retention system allows for added convenience and decreases the cost of changing or replacing the saw blade.

Other objects, features and advantages of the present invention will be readily appreciated as the same becomes better understood after reading the following description taken in conjunction with the accompanying drawings.

BRIEF DESCRIPTION OF THE DRAWINGS

The invention will be further described with reference to the drawing wherein corresponding reference numerals indicate corresponding parts throughout the several views of the drawing, and wherein:

FIG. 1 is a perspective view of a saw blade retention system, according to the present invention, illustrated in operational relationship to a sternal saw system;

FIG. 2 is a fragmentary elevational view of the saw blade retention system and a sternal saw of the sternal saw system of FIG. 1;

FIG. 3 is an exploded perspective view of the saw blade retention system of FIGS. 1 and 2;

FIG. 4 is an elevational view of the saw blade retention system of FIGS. 1 through 3;

FIG. 5A is a sectional view taken along line 5—5 of FIG. 4 illustrating the saw blade retention system in an unlocked position;

FIG. 5B is a sectional view taken along line 5—5 of FIG. 4 illustrating the saw blade retention system in a locked position;

FIG. 6 is a fragmentary view of the saw blade retention system of FIG. 4 illustrating the saw blade retention system in a locked position;

FIG. 7 is an elevational view, similar to FIG. 4, of another embodiment of the saw blade retention system, showing a blade-retaining chuck held in its blade-releasing position;

FIG. 8 is an elevational view similar to FIG. 7 showing the blade-receiving chuck in its blade-securing position;

FIG. 9 is a view of a portion of the blade-receiving chuck illustrating yet another embodiment of the saw blade retention system of the invention;

FIG. 10 is a cross sectional view of another preferred embodiment of the saw blade retention system of the invention, showing the saw blade retained in place; and

FIG. 11 is a cross sectional view of the saw blade retention system of FIG. 10 with the saw blade removed from the chuck.

DESCRIPTION OF THE PREFERRED EMBODIMENT(S)

Referring to the drawings and in particular to FIG. 1 thereof, a saw blade retention system 10, according to the present invention, is illustrated in operational relationship to a reciprocating or sternal saw system, generally indicated at 12. The sternal saw system 12 includes a sternal saw 14 driven through a flexible drive shaft 16 by an electric motor 18. The electric motor 18 has a plug 20 for connection to a

foot control (not shown) which, in turn, is connected to a source of electrical power (not shown).

Referring to FIG. 2, the sternal saw 14 is a reciprocating saw designed for use in splitting a sternum of a patient during thoracic surgery. The sternal saw 14 has a conventional rotatable shaft 22 which is operatively rotated by the drive shaft 16. The sternal saw 14 also has a conventional eccentric member 24 having a first shaft mounted in a bearing 26 in the housing of the sternal saw 14 for rotation along a common axis of rotation with the rotatable shaft 22, and an eccentric shaft connected to the rotatable shaft 22 and offset from the axis of rotation of the rotatable shaft 22. The sternal saw 14 further has a reciprocating shaft 28 mounted on the eccentric shaft of the eccentric member 24 by a bearing 30. The arrangement is such that rotation of shaft 22 rotates the eccentric member 24, in turn, reciprocating the shaft 28 along its axis of reciprocation. A sternal saw having rotatable, eccentric and reciprocating shafts for reciprocating a blade has been available from Minnesota Mining and Manufacturing Company, St. Paul, Minn., under the trade designation "SARNS" Sternal Saw, Catalog No. 6090.

Referring to FIGS. 2 and 3, the novel saw blade retention system 10, according to the present invention, includes a retention shaft, generally indicated at 32. The retention shaft 32 is connected to the reciprocating shaft 28 by suitable means such as a fastener 34. Alternatively, the retention shaft 32 and the reciprocating shaft 28 could be one, integral piece. The retention shaft 32 is generally cylindrical in shape and extends longitudinally through an aperture 36 in a bushing 38 at one end of the sternal saw 14. It should be appreciated that the retention shaft 32 reciprocates due to the movement of the reciprocating shafts 28 of the sternal saw 14.

The retention shaft 32 has a main portion 40 and a first stepped portion 42 at one end of the main portion 40. The first stepped portion 42 has a diameter less than a diameter of the main portion 40. The retention shaft 32 also includes a second stepped portion 44 at the end of the first stepped portion 42 and having a diameter less than a diameter of the first stepped portion 42. The retention shaft 32 further includes a blade-receiving aperture or slot 46 extending axially through the second stepped portion 44 and into the first stepped portion 42 to a blade seat 47 for a function to be described.

The saw blade retention system 10 also includes a generally flat, elongate saw blade, generally indicated at 48. The saw blade 48 has a generally elongate blade portion 50 extending axially-longitudinally with a plurality of teeth 52. The saw blade 48 also has a shank portion 54 extending axially-longitudinally from the blade portion 50. In use, the shank portion 54 is disposed in the blade-receiving slot 46 of the retention shaft 32. The shank portion 54 is generally pentagonal in shape and has an end edge 56 which is linear or planar and side or lateral edges 58 which are linear or planar and generally perpendicular to the end edge 56.

The blade portion 50 has a free end defining the forward end of the saw blade 48, and the end edge 56 defines the rear end 56 of the saw blade 48.

The shank portion 54 also has recesses 60 axially/longitudinally aligned and extending toward each other from opposite edges of the shank portion 54 to form a reduced portion 62 having a width less than a width of the shank portion 54. The shank portion 54 also has inclined edges 64 extending from the side edges 58 to the reduced portion 62 and toward the blade portion 50. The inclined edges 64 define a rear edge 64 of each recess 60, and extend at an

inclined angle α relative to the planar end edge 56 such that the shank portion 54 can be clamped between the inclined edges 64 of each recess 60 and the planar end edge 56 to align and retain the saw blade 48 with respect to the powered reciprocating saw 14. The inclined edges 64 preferably extend at an angle ("a" in FIG. 6) of approximately 20 degrees relative to the lateral direction (i.e., the direction along the major surfaces of the blade 48 perpendicular to the longitudinal direction of the blade 48). As illustrated in FIGS. 1 and 2, the blade portion 50 may be supported at its free end by a conventional foot piece 65 connected to the sternal saw 14.

At least one non-inclined edge 63 defines the forward edge of each recess 60, and extends generally at a right angle relative to the lateral edge 58. A bottom edge 61 extends between the non-inclined edge 63 and the inclined edge 64 and defines the "bottom" of the recess 60. Most preferably, the bottom edges 61 extends generally parallel with respect to the lateral edges 58, and a radius is provided between the non-inclined edge 63 and the bottom edge 61.

Referring to FIGS. 2 through 4 and 6, the saw blade retention system 10 further includes a chuck, generally indicated at 66, for removably retaining or securing the saw blade 48 to the retention shaft 32. The chuck 66 is generally tubular and has a body portion 68 and a stem portion 70 at one axial end and a seating portion 72 at the other axial end. The body portion 68 is generally cylindrical in shape and has a first pocket 74 of a diameter to receive the shank portion 54 of the saw blade 48. The body portion 68 also has an outer surface formed with a plurality of recesses 76 extending axially and spaced laterally to form a gripping surface for a hand of an operator. It should be appreciated that the outer surface of the body portion 68 may be formed as a gripping surface by any suitable means such as knurling.

The stem portion 70 extends axially from the body portion 68 and is generally cylindrical in shape. The stem portion 70 has an outer surface of a diameter less than a diameter of the outer surface of the body portion 68. The stem portion 70 also has a second pocket 78 of a diameter to receive the main portion 40 of the retention shaft 32. The second pocket 78 has a diameter greater than a diameter of the first pocket 74. The stem portion 70 further has at least one, preferably a pair of, cam grooves or slots 80 opposing each other and extending circumferentially and axially (e.g., helically) a predetermined amount. For example, the cam slots 80 extend circumferentially about sixty-nine degrees (69°), axially forty-five thousandths (0.045) of an inch (1.14 mm), and have a helix angle of approximately 8 degrees relative to the axis of rotation of the chuck 66. It should be appreciated that the cam slots 80 may have any suitable circumferential or axial length for a function to be described.

The seating portion 72 is generally frustoconical in shape and extends axially from the body portion 68. The seating portion 72 has an annular ledge 82 at the end thereof which extends radially inwardly to form an aperture 84 having a diameter less than the diameter of the first pocket 74. The ledge 82 has a blade aperture or slot 86 extending axially through the ledge 82 of a width sufficient to allow the shank portion 54 to be received or disposed within the first pocket 74. It should be appreciated that the aperture 84 is of a sufficient diameter to allow the second stepped portion 44 of the retention shaft 32 to be received or disposed therein.

The seating portion 72 also has an interior surface 88 on ledge 82 which is conical or inclined toward the aperture 84 at a predetermined angle, such as twenty degrees (20°), for example, approximately equal to and complementary with

the angle of the inclined edges 64 of the blade 48. The interior surface 88 mates or cooperates with the inclined surfaces 64 of the shank portion 54 to center the saw blade 48 relative to an axial axis A of the retention shaft 32. It should be appreciated that the inclined surface 88 of the chuck 66 moves the shank portion 54 radially due to the contact between the inclined surface 88 and inclined edges 64 to center the saw blade 48. It should also be appreciated that the interior surface 88 cooperates with the shank portion 54 to provide a positive radial locking force to prevent radial movement of the saw blade 48 relative to the retention shaft 32.

The saw blade retention system 10 also includes a pin 90 to cooperate with the cam slots 80. The pin 90 is generally cylindrical in shape and is disposed in a pin aperture 92 extending diametrically through the main portion 40 of the retention shaft 32. Preferably, the pin 90 is made of a softer metal material than the retention shaft 32 or chuck 66 and is press-fit into the pin aperture 92. The pin 90 is of a sufficient length to extend into the cam slots 80. The pin 90 cooperates with the cam slots 80 to limit the rotation of the chuck 66 and allow axial movement of the chuck 66 relative to the retention shaft 32.

The saw blade retention system 10 further includes a spring 94 for urging the chuck 66 in a locked position when the pin 90 is at an upper end of the cam slots 80. The spring 94 is a torsional spring having first and second tangs 96 and 98. The spring 94 is disposed in an annular recess 99 extending radially inwardly between the main portion 40 and the first stepped portion 42. The first tang 96 is disposed in a tang pocket 100 extending axially into the body portion 68 of the chuck 66. The second tang 98 is disposed in a tang recess 102 extending axially into the main portion 40 of the retention shaft 32. The spring 94 is wound counterclockwise (e.g., left-hand thread) and, when relaxed, urges the chuck 66 to a locked position as illustrated in FIG. 5B.

In operation, the chuck 66 is rotated relative to the retention shaft 32 by an operator to overcome the force or torque of the spring 94. As the chuck 66 rotates, the cam slots 80 move relative to the pin 90, in turn, moving the chuck 66 axially away from the retention shaft 32. The saw blade retention system 10 has an unlocked position when the slot 86 in the chuck 66 is aligned with the slot 46 in the retention shaft 32 as illustrated in FIG. 5A. In the unlocked position, the pin 90 is at a lower end of the cam slots 80 and interior surface 88 is at a maximum distance from the blade seat 47. The saw blade 48 is inserted through the slot 86 and into the slot 46 until the end edge 56 contacts the blade seat 47.

Next, the chuck 66 is released. The spring 94 relaxes and rotates the chuck 66 relative to the retention shaft 32. As the chuck 66 rotates, the cam slots 80 move relative to the pin 90, in turn, moving the chuck 66 axially toward the retention shaft 32 and reducing the distance between the interior surface 88 and the blade seat 47. Since the chuck 66 and retention shaft 32 are coaxial, the interior surface 88 contacts the inclined edges 64 of the shank portion 54 to provide a force to center the saw blade 48 relative the axial axis A of the retention shaft 32. The saw blade retention system 10 has a locked position when the slot 86 in the chuck 66 are not aligned with the blade-receiving slot 46 in the retention shaft 32 as illustrated in FIG. 5B. In the locked position, the pin 90 is at an upper end of the cam slots 80 and the interior surface 88 and blade seat 47 contact the inclined edges 64 and end edge 56, respectively, of the saw blade 48 to provide a three point pinch or line contact, trapping the saw blade 48 and preventing rotational and axial movement thereof. The operation is reversed to unlock and remove the saw blade 48.

As used herein, the "locked" position refers to the position in which the chuck 66 "locks" or secures the saw blade 48 on the sternal saw 14, and the "unlocked" or "open" position refers to the position in which the chuck 66 does not hold the saw blade in the sternal saw 14. In the "locked" position, the slot 86 of the chuck 66 is not aligned with the blade-receiving slot 46 of the retention shaft 32. In the "unlocked" position, the slot 86 of the chuck 66 is aligned with the blade-receiving slot 46 of the retention shaft 32. As such, the chuck 66 can be "locked" or held in its "unlocked" or "open" position for example by a detent, as discussed below with respect to FIGS. 7-9.

Accordingly, the saw blade retention system 10 incorporates a self-centering blade feature due to the interior surface 88 of the chuck 66 and the inclined edges 64 of the saw blade 48. The saw blade retention system 10 also incorporates a positive axial and radial locking action due to the interior surface 88 and blade seat 47 to trap the saw blade 48. The saw blade retention system 10 also eliminates the use of screws and screwdrivers by providing a ledge 82 and slot 86 for alignment and misalignment with the saw blade 48 and retention shaft 32 to allow insertion and retention of the saw blade 48 to the retention shaft 32.

FIGS. 7 and 8 illustrate an alternative embodiment of the saw blade retention system of the invention, here designated 110. The saw blade retention system 110 includes a blade-retaining chuck 166, similar to chuck 66, but having generally L-shaped cam slots 180. One leg 180A of each of the L-shaped cam slots 180 is similar to cam slots 66, and the other leg 180B of the cam slots 180 provides a detent or locking feature to lock the chuck 166 in its blade-unlocked or open position (FIG. 7) relative to pin 190. Leg 180A will be referred to as the "cam" leg 180A, and leg 180B will be referred to as the "detent" leg 180B.

In its open position (FIG. 7), the chuck 166 will allow saw blades 148 to be inserted into or removed from the chuck 166. The chuck 166 can be moved to its closed or blade-locking position (FIG. 8) by pressing the saw blade 148 or chuck 166 toward the main body of the sternal saw 14 as indicated at F, thereby moving the chuck 166 relative to the pin 190 until the pin 190 is in the cam leg 180A of the chuck 166, and rotating the chuck 166 or allowing the chuck 166 to rotate according to the bias of its torsion spring (not shown but similar in some respects to torsion spring 94) to its closed position. In its closed position, the blade aperture or slot (not shown but similar to slot 86) is not aligned with the blade-receiving slot of the retention shaft (not shown but similar to slot 46 in retention shaft 32) so that the blade 148 cannot be removed from the chuck 166. The longitudinal position that the locked "open" chuck 166 would be in is indicated in phantom in FIG. 8 relative to the "closed" chuck 166.

The torsion spring of the blade retention system 110 is similar in some respects to the torsion spring 94 but in use may be more thoroughly characterized as a compression/torsion spring. The compression/torsion spring provides two different biasing forces having different consequences depending upon whether the pin 190 is in the cam leg 180A or the detent leg 180B.

When the pin 190 is in the cam leg 180A, the compression/torsion spring functions identically to the torsion spring 94 is bias the chuck 166 toward its closed, blade-retaining position, in which the torsional bias of the spring tends to increase the space between the pin 190 and the detent leg 180B of the chuck 166. When the pin 190 is in the detent leg 180B the compressive/expansive bias of the

spring urges the chuck 166 away from the retention shaft to releasably lock the pin 190 in the closed end of the detent leg 180B. It will be appreciated that the compression/torsion spring may provide both of these biases, compression and torsion, when the chuck 166 is in its closed and open positions and when moved between those positions but that the practical result of the biases should be to urge the chuck 166 as specified. Alternately, two separate springs (not shown) may be provided, one being a torsion spring similar to torsion spring 94 and the other being a coil compression spring, for example, which merely biases the chuck away from the retention shaft.

In this alternate embodiment, the blade portion 150 of the saw blade 148 is preferably wider than the distance covered between the ends of the blade-receiving slots (not shown but similar to slots 86) so that the longitudinal force F to release the pin 190 from the detent leg 180B may be applied by pushing the saw blade 148 toward the sternal saw. The self-centering feature provided by the inclined edges 64 of the saw blade 48 and the inclined surfaces 88 of the chuck 66 of the embodiment of FIGS. 1-6 may also be provided in the embodiment of FIGS. 7-8.

FIG. 9 illustrates another alternative embodiment of the saw blade retention system, here designated 210, of the invention. Saw blade retention system 210 is similar in many respects to saw blade retention system 110 but additionally includes a detent notch 281 for releasably holding the chuck 266 relative to the pin 290 in the open position, and the cam slot 280 additionally includes an open end 280C allowing the chuck 266 to be placed on the sternal saw while the pin 290 is in the retention shaft.

The saw blade retention system 210 may be assembled after the pin 290 has been inserted into the retention shaft (not shown but similar to retention shaft 32) by aligning the open ends 280C of the cam slots 280 relative to the free ends of the pin 290 and pushing the chuck 266 onto the retention shaft. When the pin 290 has reached the inner end of the open portion 280C of the cam slot 280, the chuck 266 is rotated to bring the pin 290 into the cam leg 280A of the cam slot 280. The cam leg 280A includes the detent notch 281 for releasably locking the chuck 266 in its locked, blade-retaining position on the pin 290.

The open portion 280C of the cam slot 280 and the other portions 280A and 280B of the cam slot 280 define a cantilever arm 267 that, while stiff, has some springiness or flexibility so as to deflect slightly when the pin 290 is moved in or out of the detent notch 281. The cantilever arm 267, however, is preferably sufficiently stiff that the pin 290 cannot pass over a raised stop 267A at its free end when a blade (not shown but similar to blade 48 or 148) is inserted in the chuck 266. The chuck 266, however, can be released from the pin 290 for cleaning or maintenance when a blade (not shown) is not inserted into the chuck 266 by simply turning the chuck 266 relative to the pin 290 until the pin 290 is received in the open portion 280C of the cam slot 280.

FIGS. 10 and 11 illustrates another preferred embodiment of the saw blade retention system, here designated 300, of the invention. The saw blade 302 of saw blade retention system 300 includes a generally elongate blade portion 304 having a plurality of saw teeth and a free end 305, and a shank portion 306. The shank portion 306 is generally planar having opposite major surfaces, opposite lateral edges 308, and a generally linear or planar end edge 310.

The end edge 310 of the shank portion 306 is generally perpendicular to the longitudinal axis of the saw blade 302, and the lateral edges 308 are generally parallel to the

longitudinal axis of the saw blade 302. The free end 305 of the blade portion 304 defines the forward end 305 of the saw blade 302, and the end edge 310 of the shank portion 306 defines the rear end 310 of the saw blade 302.

Opposite projecting portions 312 extend laterally outwardly from the opposite lateral edges 308 of the shank portion 306. An inclined forward edge 314 is provided on each projecting portion 312, with the inclined forward edges 314 extending at an inclined angle relative to the planar end edge 310. Most preferably, each inclined forward edge 314 extends at an angle of about twenty degrees relative to the planar end edge 310, with the inclined forward edges 314 extending at an angle of about 140 degrees relative to one another and at an angle of about 110 degrees relative to the longitudinal axis of the saw blade 302. Also, as illustrated in FIGS. 10 and 11, a chuck 316 and shaft 318 are provided as part of a reciprocating saw. The shaft 318 is mounted in the saw for reciprocation, and has a first blade-receiving slot (similar to the first blade-receiving slot 46 of FIG. 3) at one end of the shaft 318 for receiving the shank portion 306 of the saw blade 302. The first blade-receiving slot has a bottom end (similar to end 47 in FIG. 3) and an open end.

The chuck 316 is disposed about the shaft 318, and has an annular ledge 320 extending radially inwardly at one end to define a blade-receiving opening 322. The ledge 320 has a second blade-receiving slot (similar to slot 86 in FIG. 3) extending therethrough and generally radially outwardly from the opening 322.

The chuck 316 is mounted on the saw for rotation relative to the shaft 318 between an unlocked position and a locked position. In the unlocked position (similar to FIG. 5A), the second blade-receiving slot of the chuck 316 is aligned with the first blade-receiving slot of the shaft 318 to allow the saw blade 302 to be inserted into the first and second blade-receiving slots. In the locked position (similar to FIG. 5B), the first and second blade-receiving slots of the shaft 318 and chuck 316, respectively, are not aligned such that the ledge 320 of the chuck 316 engages the inclined edges 314 of the projecting portions 312 of the saw blade 302 to hold the saw blade 302 in the first blade-receiving slot.

Preferably, the ledge 320 of the chuck 316 has a generally frustoconical surface generally complementary to the inclined edges 314 of the projecting portions 312 of the saw blade 302. When the chuck 316 is moved to its locked position, the frustoconical surface of the ledge 320 engages the inclined edges 314 of the saw blade 302 to push and hold the end edge 310 of the saw blade 302 against the bottom of the first blade-receiving slot of the shaft 318, and the saw blade 302 tends to be centered by the forces applied by the frustoconical surface of the ledge 320 and the bottom of the first blade-receiving slot of the shaft 318. Most preferably, the frustoconical surface of the chuck 316 is disposed at an angle of approximately 20 degrees relative to the bottom of the first blade-receiving slot.

The blade-receiving opening 322 of the chuck 316 has a diameter at least as large as the distance between the opposite lateral edges 308 of the shank portion 306 of the saw blade 302 but less than the distance between the free ends 324 of the projecting portions 312 of the saw blade 302. Most preferably, the diameter of the blade-receiving opening 322 is only slightly greater than the distance between the opposite lateral edges 308 of the shank portion 306 of the saw blade 302.

Also, preferably, cam slots are provided in one of the chuck 316 and shaft 318, and a pin 326 is mounted on the other of the chuck 316 and shaft 318 with the pin 326

extending into the cam slots. FIG. 11 shows the pin 326 mounted in the shaft 318. The cam slots are disposed at a helical angle relative to the axis of rotation of the chuck 316 such that the frustoconical surface of the ledge 320 moves closer to the bottom of the first blade-receiving slot of the shaft 318 as the chuck 316 is rotated from its unlocked position toward its locked position. For example, the helical angle of the cam slots may be approximately eight degrees.

Suitable biasing means is also provided for biasing the chuck 316 toward its locked position. For example, the biasing means may comprise a torsion spring, similar to spring 94 of FIG. 3, operatively linked with the chuck 316 and shaft 318 to bias the chuck 316 toward its locked position relative to the shaft 318.

Detent means may optionally be provided for releasably securing the chuck 316 in its unlocked position to facilitate inserting the saw blade 302. Such detent means are illustrated at 180B and 280B in FIGS. 7-9.

As various changes could be made in the above constructions without departing from the scope of the invention as defined in the claims, it is intended that all matter contained in the above description or shown in the drawing be interpreted as illustrative and not in a limiting sense.

I claim:

1. A surgical saw blade for retention by a powered reciprocating saw and being adapted to be aligned with respect to a path of reciprocation relative to the powered reciprocating saw, the saw blade comprising:

a generally elongate blade portion having a plurality of teeth and a free end defining a forward end of the saw blade; and

a shank portion extending from the blade portion for connection to a reciprocating saw, the blade having a longitudinal axis extending through the saw blade and shank portions, the shank portion being generally planar having:

opposite major surfaces;

generally parallel opposite lateral edges generally parallel with the longitudinal axis of the saw blade;

a generally planar end edge generally perpendicular to the longitudinal axis of the blade and shank portions and extending between the opposite lateral edges, the planar end edge defining a rear end of the saw blade; and

recess-defining edges defining a pair of recesses extending generally laterally inwardly along the shank portion from the opposite edges of the shank portion, the recess-defining edges of each recess including:

at least one non-inclined edge, defining a forward edge of each recess, extending approximately at a right angle relative to the lateral edge;

at least one inclined edge, defining a rear edge of each recess, extending at an inclined angle relative to the planar end edge such that the shank portion can be clamped between the inclined edges of each recess and the planar end edge to align and retain the saw blade with respect to a powered reciprocating saw; and

a bottom edge extending between the non-inclined edge and the inclined edge.

2. A saw blade according to claim 1 wherein the inclined edges extend at an angle of about 110 degrees relative to the longitudinal axis of the saw blade.

3. A saw blade according to claim 1 wherein the inclined edges are disposed at an angle of about twenty degrees relative to the planar end edge.

4. A saw blade according to claim 1 wherein the inclined edges are disposed at an angle of about 140 degrees relative to one another.

5. A saw blade according to claim 1 wherein the bottom edges are generally parallel with the opposite lateral edges of the saw blade.

6. A surgical saw blade for retention to a powered reciprocating saw, the saw blade comprising:

a blade portion having a plurality of teeth and a free end defining a forward end of the saw blade; and

a shank portion extending from the blade portion for connection to a reciprocating saw, the blade having a longitudinal axis extending through the blade and shank portions, the shank portion being generally planar having:

opposite major surfaces;

opposite lateral edges;

a generally planar end edge generally perpendicular to the longitudinal axis of the blade and shank portions and extending between the opposite lateral edges, the planar end edge defining a rear end of the saw blade; and

opposite projecting portions projecting laterally outwardly from the opposite lateral edges of the shank portion, each projecting portion including at least one inclined forward edge portion extending at an inclined angle relative to the planar end edge.

7. A saw blade according to claim 6 wherein the inclined forward edge of each projecting portion extends at an angle of about 110 degrees relative to the longitudinal axis of the saw blade.

8. A saw blade according to claim 6 wherein the inclined forward edge of each projecting portion is disposed at an angle of about twenty degrees relative to the planar end edge.

9. A saw blade according to claim 6 wherein the inclined forward edges of the projecting portions are disposed at an angle of about 140 degrees relative to one another.

10. A surgical saw blade retention system for a reciprocating saw, the system comprising:

(A) a surgical saw blade comprising:

a blade portion having a plurality of teeth and a free end defining a forward end of the saw blade; and

a shank portion extending from the blade portion for connection to a reciprocating saw, the blade having a longitudinal axis extending through the blade and shank portions, the shank portion being generally planar having opposite major surfaces, opposite lateral edges, a generally planar end edge generally perpendicular to the longitudinal axis of the blade and shank portions and extending between the opposite lateral edges, the planar end edge defining a rear end of the saw blade, and opposite projecting portions projecting laterally outwardly from the opposite lateral edges of the shank portion, each projecting portion including at least one inclined forward edge portion extending at an inclined angle relative to the planar end edge; and

(B) a reciprocating saw comprising:

a shaft mounted in the saw for reciprocation and having a first blade-receiving slot at one end of the shaft for receiving the shank portion of the saw blade, the first blade-receiving slot having a bottom end and an open end; and

a chuck disposed about the shaft and having an annular ledge extending radially inwardly at one end to define a blade-receiving opening, the ledge having a

second blade-receiving slot extending therethrough and generally radially outwardly from the opening, the chuck being mounted on the saw for rotation relative to the shaft between an unlocked position, wherein the second blade-receiving slot is aligned with the first blade-receiving slot to allow the saw blade to be inserted into the first and second blade-receiving slots, and a locked position, wherein the first and second blade-receiving slots are not aligned such that the ledge of the chuck engages the inclined edges of the projecting portions of the saw blade to hold the saw blade in the first blade-receiving slot; the ledge of the chuck having a generally frustoconical surface generally complementary to the inclined edges of the projecting portions of the saw blade for engagement with the inclined edges of the saw blade when the chuck is moved to its locked position such that the end edge of the saw blade is held against the bottom of the first blade-receiving slot and the saw blade tends to be centered by the forces applied by the frustoconical surface and the bottom of the first blade-receiving slot.

11. A surgical saw blade retention system according to claim 10 wherein the projecting portions of the saw blade have free ends, the blade-receiving opening of the chuck having a diameter at least as large as the distance between the opposite lateral edges of the shank portion of the saw blade but less than the distance between the free ends of the projecting portions of the saw blade.

12. A surgical saw blade retention system according to claim 11 further comprising:

cam slots in one of the chuck and shaft; and

a pin mounted on the other of the chuck and shaft and extending into the cam slots;

the cam slots being disposed at a helical angle relative to the axis of rotation of the chuck such that the frustoconical surface of the ledge moves closer to the bottom of the first blade-receiving slot as the chuck is rotated from its unlocked position toward its locked position.

13. A surgical saw blade retention system according to claim 12 wherein the inclined forward edges of the projecting portions of the saw blade are disposed at an angle of approximately 20 degrees relative to the end edge of the saw blade, the frustoconical surface of the chuck being disposed at an angle of approximately 20 degrees relative to the bottom of the first blade-receiving slot, and the helical angle of the cam slots being approximately eight degrees.

14. A surgical saw blade retention system according to claim 12 further comprising biasing means for biasing the chuck toward its locked position.

15. A surgical saw blade retention system according to claim 14 wherein the biasing means comprises a torsion spring operatively linked with the chuck and shaft to bias the chuck toward its locked position relative to the shaft.

16. A surgical saw blade retention system according to claim 15 further comprising detent means for releasably securing the chuck in its unlocked position to facilitate inserting the saw blade.

17. A saw blade retention system according to claim 10 wherein the inclined forward edge of each projecting portion extends at an angle of about 110 degrees relative to the longitudinal axis of the saw blade.

18. A saw blade retention system according to claim 10 wherein the inclined forward edge of each projecting portion is disposed at an angle of about twenty degrees relative to the planar end edge.

19. A saw blade retention system according to claim 10 wherein the inclined forward edges of the projecting por-

tions are disposed at an angle of about 140 degrees relative to one another.

20. A surgical saw blade retention system for a reciprocating saw, the system comprising:

(A) a surgical saw blade comprising a generally elongate blade portion having a plurality of teeth and a free end defining a forward end of the saw blade;

and a shank portion extending from the blade portion for connection to a reciprocating saw, the blade having a longitudinal axis extending through the saw blade and shank portions, the shank portion being generally planar having opposite major surfaces; generally parallel opposite lateral edges generally parallel with the longitudinal axis of the saw blade; a generally planar end edge generally perpendicular to the longitudinal axis of the blade and shank portions and extending between the opposite lateral edges, the planar end edge defining a rear end of the saw blade; and recess-defining edges defining a pair of recesses extending generally laterally inwardly along the shank portion from the opposite edges of the shank portion, the recess-defining edges of each recess including:

at least one non-inclined edge, defining a forward edge of each recess, extending approximately at a right angle relative to the lateral edge;

at least one inclined edge, defining a rear edge of each recess, extending at an inclined angle relative to the planar end edge such that the shank portion can be clamped between the inclined edges of each recess and the planar end edge to align and retain the saw blade with respect to a powered reciprocating saw; and

a bottom edge extending between the non-inclined edge and the inclined edge; and

(B) a reciprocating saw comprising:

a shaft mounted in the saw for reciprocation and having a first blade-receiving slot at one end of the shaft for receiving the shank portion of the saw blade, the first blade-receiving slot having a bottom end and an open end; and

a chuck disposed about the shaft and having an annular ledge extending radially inwardly at one end to define a blade-receiving opening, the ledge having a second blade-receiving slot extending therethrough and generally radially outwardly from the opening, the chuck being mounted on the saw for rotation relative to the shaft between an unlocked position, wherein the second blade-receiving slot is aligned with the first blade-receiving slot to allow the saw blade to be inserted into the first and second blade-receiving slots, and a locked position, wherein the first and second blade-receiving slots are not aligned such that the ledge of the chuck engages the inclined edges of the saw blade to hold the saw blade in the first blade-receiving slot;

the ledge of the chuck having a generally frustoconical surface generally complementary to the inclined edges of the saw blade for engagement with the inclined edges of the saw blade when the chuck is moved to its locked position such that the end edge of the saw blade is held against the bottom of the first blade-receiving slot and the saw blade tends to be centered by the forces applied by the frustoconical surface and the bottom of the first blade-receiving slot.

21. A surgical saw blade retention system according to claim 20 wherein the blade-receiving opening of the chuck has a diameter at least as large as the distance between the

opposing recesses of the saw blade but less than the distance between the lateral edges of the shank portion of the saw blade.

22. A surgical saw blade retention system according to claim 21 further comprising:

cam slots in one of the chuck and shaft; and

a pin mounted on the other of the chuck and shaft and extending into the cam slots;

the cam slots being disposed at a helical angle relative to the axis of rotation of the chuck such that the frustoconical surface of the ledge moves closer to the bottom of the first blade-receiving slot as the chuck is rotated from its unlocked position toward its locked position.

23. A surgical saw blade retention system according to claim 22 wherein the inclined edges of the saw blade are disposed at an angle of approximately 20 degrees relative to the end edge of the saw blade, the frustoconical surface of the chuck being disposed at an angle of approximately 20 degrees relative to the bottom of the first blade-receiving slot, and the helical angle of the cam slots being approximately eight degrees.

24. A surgical saw blade retention system according to claim 22 further comprising biasing means for biasing the chuck toward its locked position.

25. A surgical saw blade retention system according to claim 24 wherein the biasing means comprises a torsion spring operatively linked with the chuck and shaft to bias the chuck toward its locked position relative to the shaft.

26. A surgical saw blade retention system according to claim 25 further comprising detent means for releasably securing the chuck in its unlocked position to facilitate inserting the saw blade.

27. A surgical saw blade for retention by a powered reciprocating saw and being adapted to be aligned with respect to a path of reciprocation relative to the powered reciprocating saw, the saw blade being generally rectangular and comprising:

a generally elongate blade portion having a plurality of teeth and a free end defining a forward end of the saw blade; and

a shank portion extending from the blade portion for connection to a reciprocating saw, the blade having a longitudinal axis extending through the saw blade and shank portions, the shank portion being generally planar having:

opposite major surfaces;

generally parallel opposite lateral edges generally parallel with the longitudinal axis of the saw blade;

a generally planar end edge generally perpendicular to the longitudinal axis of the blade and shank portions and extending between the opposite lateral edges, the planar end edge defining a rear end of the saw blade; and

recess-defining edges defining a pair of recesses extending generally laterally inwardly along the shank portion from the opposite edges of the shank portion, the recess-defining edges of each recess including at least one inclined edge, defining a rear edge of each recess, extending at an inclined angle relative to the planar end edge such that the shank portion can be clamped between the inclined edges of each recess and the planar end edge to align and retain the saw blade with respect to a powered reciprocating saw.

28. A saw blade according to claim 27 wherein the inclined edges extend at an angle of about 110 degrees relative to the longitudinal axis of the saw blade.

29. A saw blade according to claim 27 wherein the inclined edges are disposed at an angle of about twenty degrees relative to the planar end edge.

30. A saw blade according to claim 27 wherein the inclined edges are disposed at an angle of about 140 degrees relative to one another.

31. A saw blade according to claim 27 wherein each recess-defining edge further includes a bottom edge generally parallel with the opposite lateral edges of the saw blade.

32. A saw blade according to claim 27 wherein the teeth are spaced apart from the free end of the blade portion.

33. A saw blade according to claim 32 wherein each recess-defining edge further includes a bottom edge generally parallel with the opposite lateral edges of the saw blade.

34. A saw blade according to claim 33 wherein the inclined edges extend at an angle of about 110 degrees relative to the longitudinal axis of the saw blade.

35. A saw blade according to claim 33 wherein the inclined edges are disposed at an angle of about twenty degrees relative to the planar end edge.

36. A saw blade according to claim 33 wherein the inclined edges are disposed at an angle of about 140 degrees relative to one another.

37. A surgical saw blade for retention to a powered reciprocating saw, the saw blade being generally rectangular and comprising:

a blade portion having opposite substantially parallel lateral edges, a plurality of teeth cut into one of the lateral edges, and a free end; and

a shank portion extending from the blade portion for connection to a reciprocating saw, the blade having a longitudinal axis extending through the blade and shank portions, the shank portion being generally planar having:

opposite major surfaces;

opposite lateral edges;

a generally planar end edge generally perpendicular to the longitudinal axis of the blade and shank portions and extending between the opposite lateral edges; and

a pair of inclined forward edge portions extending at opposite inclined angles relative to the planar end edge.

38. A saw blade according to claim 37 wherein the inclined forward edges extend at opposite angles of about 110 degrees relative to the longitudinal axis of the saw blade.

39. A saw blade according to claim 37 wherein the inclined forward edges are disposed at opposite angles of about twenty degrees relative to the planar end edge.

40. A saw blade according to claim 37 wherein the inclined forward edges are disposed at an angle of about 140 degrees relative to one another.

41. A saw blade according to claim 37 wherein the teeth are spaced apart from the free end of the blade portion.

42. A saw blade according to claim 41 wherein the inclined forward edges extend at opposite angles of about 110 degrees relative to the longitudinal axis of the saw blade.

43. A saw blade according to claim 41 wherein the inclined forward edges are disposed at opposite angles of about twenty degrees relative to the planar end edge.

44. A saw blade according to claim 41 wherein the inclined forward edges are disposed at an angle of about 140 degrees relative to one another.

45. A surgical saw blade for retention by a powered reciprocating saw and being adapted to be aligned with respect to a path of reciprocation relative to the powered reciprocating saw, the saw blade comprising:

a generally elongate blade portion having a lateral edge, a free end, and a plurality of teeth extending along the lateral edge and spaced from the free end; and

a shank portion extending from the blade portion for connection to a reciprocating saw, the blade having a

longitudinal axis extending through the saw blade and shank portions, the shank portion being generally planar having:

opposite major surfaces;

a generally planar end edge generally perpendicular to the longitudinal axis of the blade and shank portions and extending between the opposite lateral; and

recess-defining edges defining a pair of recesses extending generally laterally inwardly along the shank portion from the opposite edges of the shank portion, the recess-defining edges of each recess including at least one inclined edge, defining a rear edge of each recess, extending at an inclined angle relative to the planar end edge such that the shank portion can be clamped between the inclined edges of each recess and the planar end edge to align and retain the saw blade with respect to a powered reciprocating saw.

46. A saw blade according to claim 45 wherein the inclined edges extend at an angle of about 110 degrees relative to the longitudinal axis of the saw blade.

47. A saw blade according to claim 45 wherein the inclined edges are disposed at an angle of about twenty degrees relative to the planar end edge.

48. A saw blade according to claim 45 wherein the inclined edges are disposed at an angle of about 140 degrees relative to one another.

49. A saw blade according to claim 45 wherein each recess-defining edge further includes a bottom edge generally parallel with the opposite lateral edges of the saw blade.

50. A saw blade according to claim 49 wherein the inclined edges extend at an angle of about 110 degrees relative to the longitudinal axis of the saw blade.

51. A saw blade according to claim 49 wherein the inclined edges are disposed at an angle of about twenty degrees relative to the planar end edge.

52. A saw blade according to claim 49 wherein the inclined edges are disposed at an angle of about 140 degrees relative to one another.

53. A surgical saw blade for retention to a powered reciprocating saw, the saw blade comprising:

a blade portion having a free end, opposite lateral edges, a plurality of teeth cut into one of the lateral edges, the teeth being spaced apart from the free end; and

a shank portion extending from the blade portion for connection to a reciprocating saw, the blade having a longitudinal axis extending through the blade and shank portions, the shank portion being generally planar having:

opposite major surfaces;

opposite lateral edges;

a generally planar end edge generally perpendicular to the longitudinal axis of the blade and shank portions and extending between the opposite lateral edges; and

a pair of inclined forward edge portions extending at opposite inclined angles relative to the planar end edge.

54. A saw blade according to claim 53 wherein the inclined forward edges extend at opposite angles of about 110 degrees relative to the longitudinal axis of the saw blade.

55. A saw blade according to claim 53 wherein the inclined forward edges are disposed at opposite angles of about twenty degrees relative to the planar end edge.

56. A saw blade according to claim 53 wherein the inclined forward edges are disposed at an angle of about 140 degrees relative to one another.