

US00RE36099E

United States Patent [19]
Gordon

[11] E

Patent Number: Re. 36,099

[45] Reissued Date of Patent: Feb. 16, 1999

[54] X-RAY TOMOGRAPHY APPARATUS

[75] Inventor: Bernard M. Gordon, Magnolia, Mass.

[73] Assignee: Analogic Corporation, Peabody, Mass.

[21] Appl. No.: 16,004

[22] Filed: Feb. 10, 1993

4,448,200	5/1984	Brooks et al.	378/20
4,472,822	9/1984	Swift	378/17
4,555,631	11/1985	Martens	
4,570,264	2/1986	Liebetrueth	378/4 X
4,630,202	12/1986	Mori	378/15 X
4,651,007	3/1987	Perusek et al.	250/363 SC
4,677,554	6/1987	Dobbs et al.	
4,712,178	12/1987	Tuy et al.	
4,797,907	1/1989	Anderton	378/101
4,928,283	5/1990	Gordon	378/20
4,977,588	12/1990	Van der Ende	378/20
5,226,064	7/1993	Yahata et al.	378/4

Related U.S. Patent Documents

Reissue of:

[64] Patent No.: 4,928,283
 Issued: May 22, 1990
 Appl. No.: 160,657
 Filed: Feb. 26, 1988

U.S. Applications:

[63] Continuation of Ser. No. 744,112, Aug. 9, 1991, Pat. No. Re. 34,379.

[51] Int. Cl.⁶ H05G 1/02

[52] U.S. Cl. 378/20; 378/11; 378/196; 250/363.05

[58] Field of Search 378/4, 11-14, 378/17, 20, 101, 102, 112, 103, 18, 195, 196, 197, 198; 250/363.05

[56] **References Cited**

U.S. PATENT DOCUMENTS

Re. 34,379	9/1993	Gordon	378/20
3,125,679	3/1964	Ohde et al.	378/102
3,889,116	6/1975	Gambini et al.	378/91 X
4,138,721	2/1979	Boyd	378/17
4,201,430	5/1980	Dinwiddle et al.	
4,348,590	9/1982	Daniels et al.	378/115
4,426,715	1/1984	Baer et al.	378/4

FOREIGN PATENT DOCUMENTS

0018872	11/1980	European Pat. Off.	
8429531	4/1986	Germany	
8703190	6/1988	Germany	
2007938	5/1979	United Kingdom	

Primary Examiner—David P. Porta
Attorney, Agent, or Firm—Lappin & Kusmer LLP

[57] **ABSTRACT**

Accordingly, the present invention provides an x-ray tomography apparatus having a patient table, x-ray tomography components located around the patient table and in an imaginary plane which intersects the table, and structure for supporting the table and tomography components and including apparatus for moving the tomography components along at least a portion of the table. In an alternate embodiment, an x-ray tomography apparatus includes an annular x-ray tomography system for continuously rotating around a patient, which structure has an electrically powered x-ray source and battery power for supplying electrical power to the x-ray source.

50 Claims, 4 Drawing Sheets

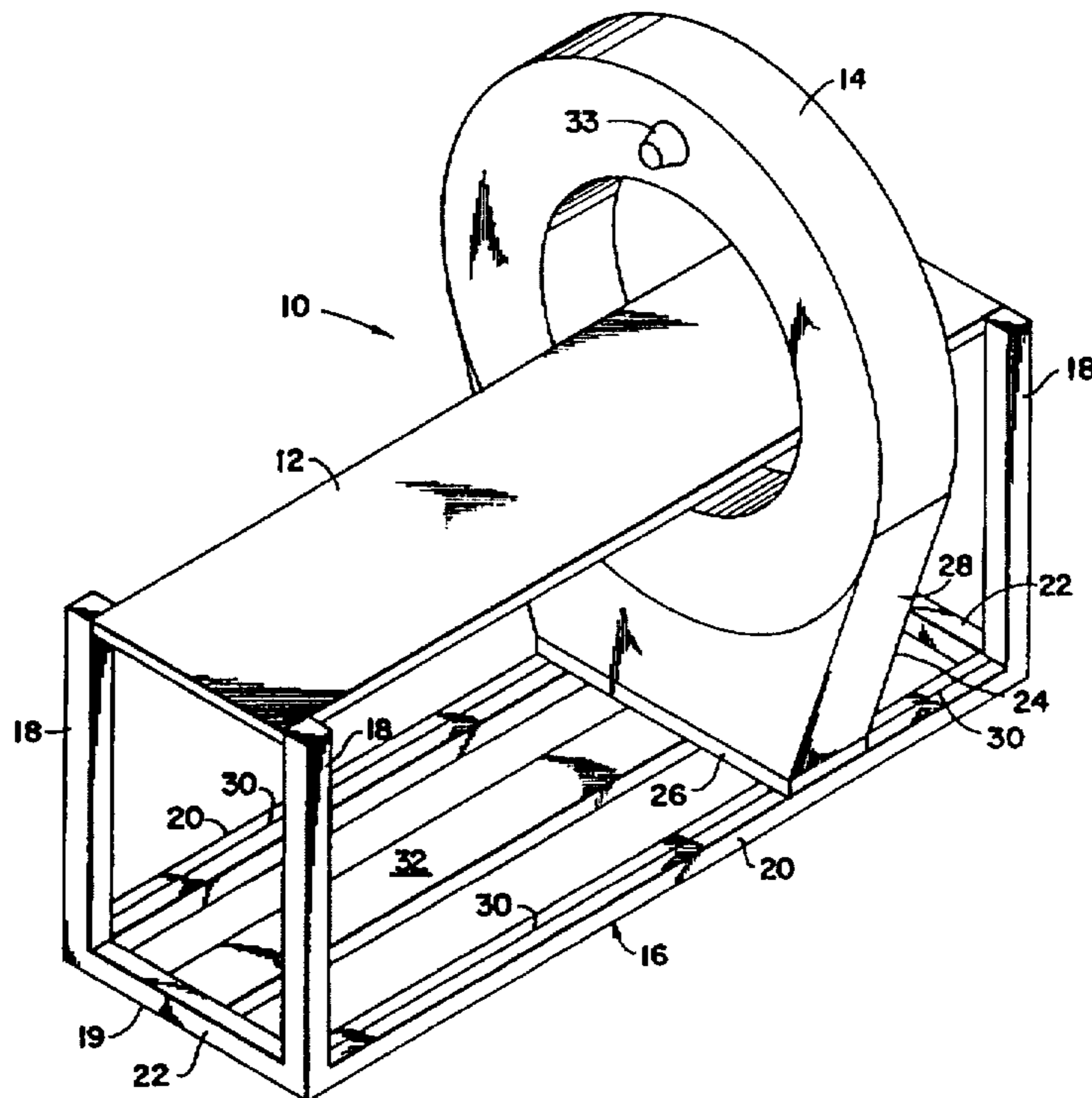

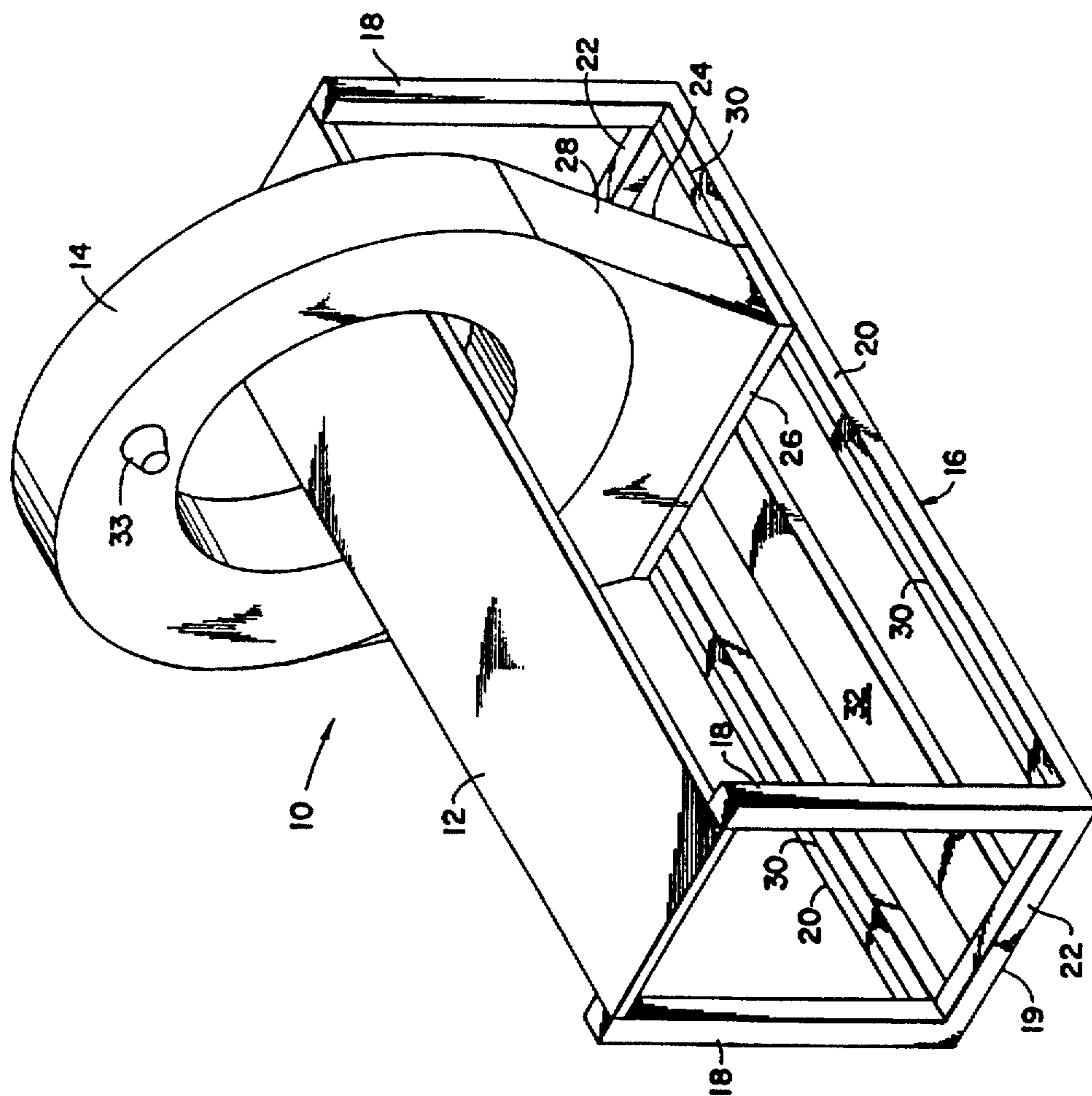

FIG. 1

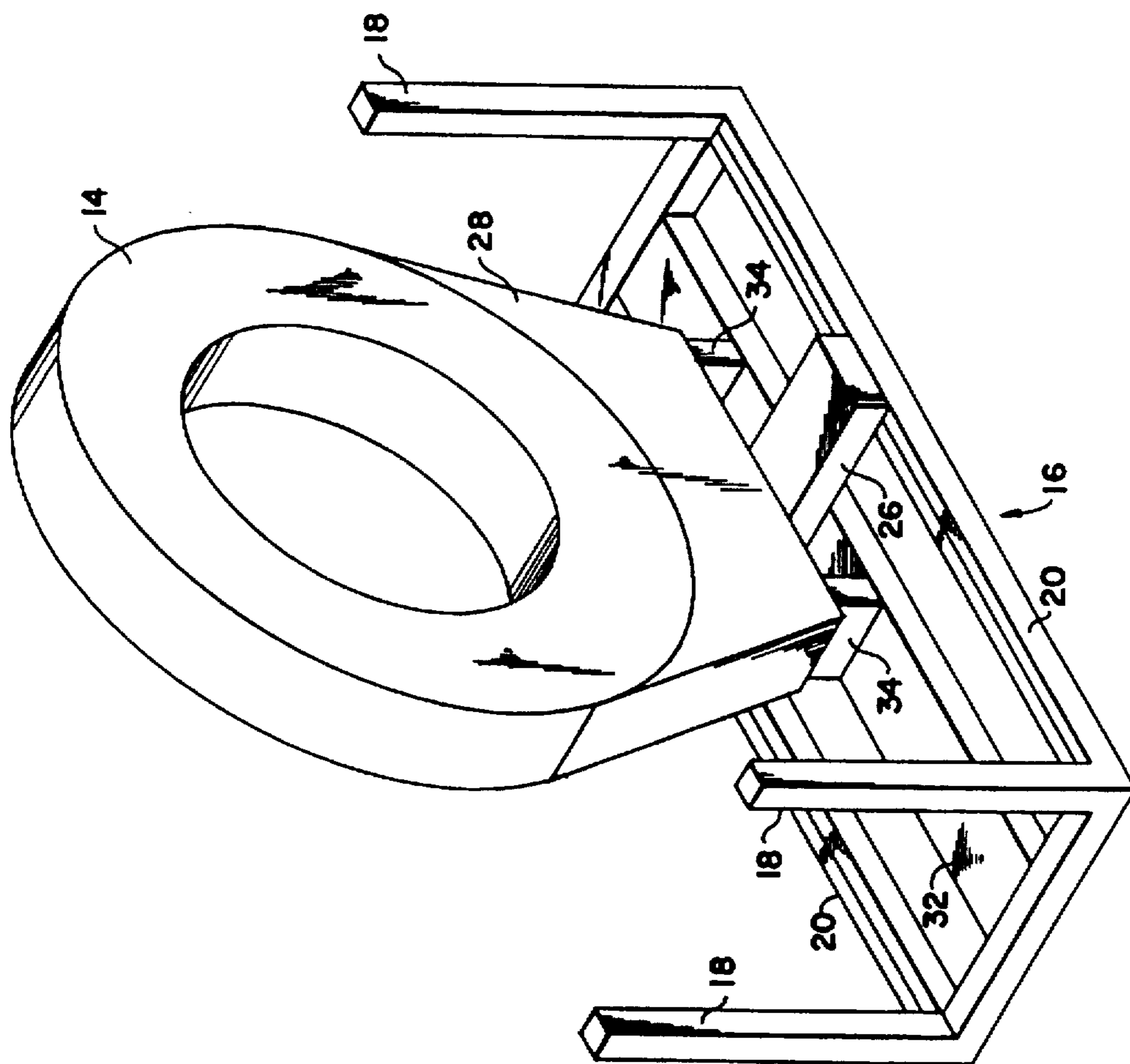

FIG. 2

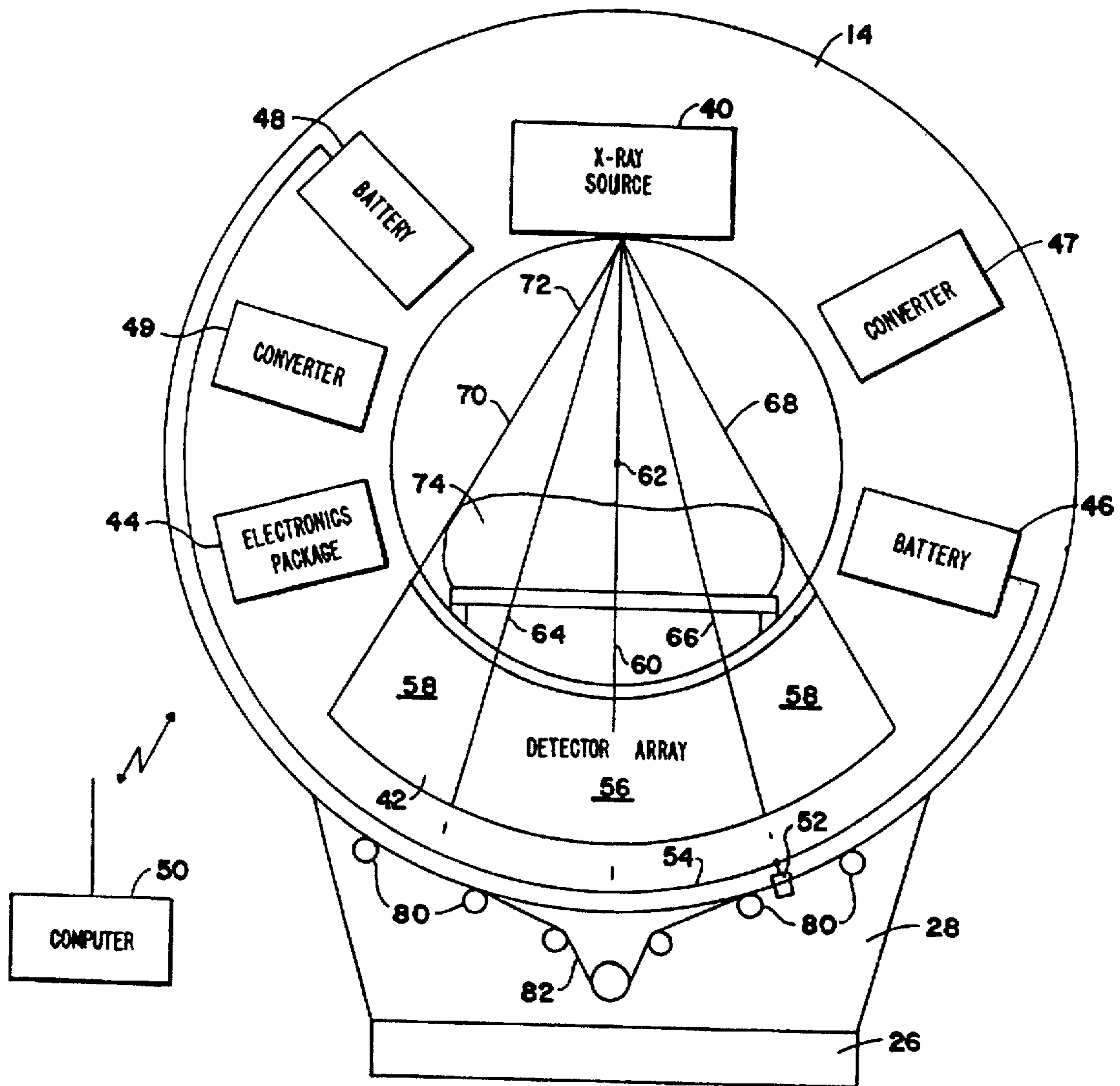

Fig. 3

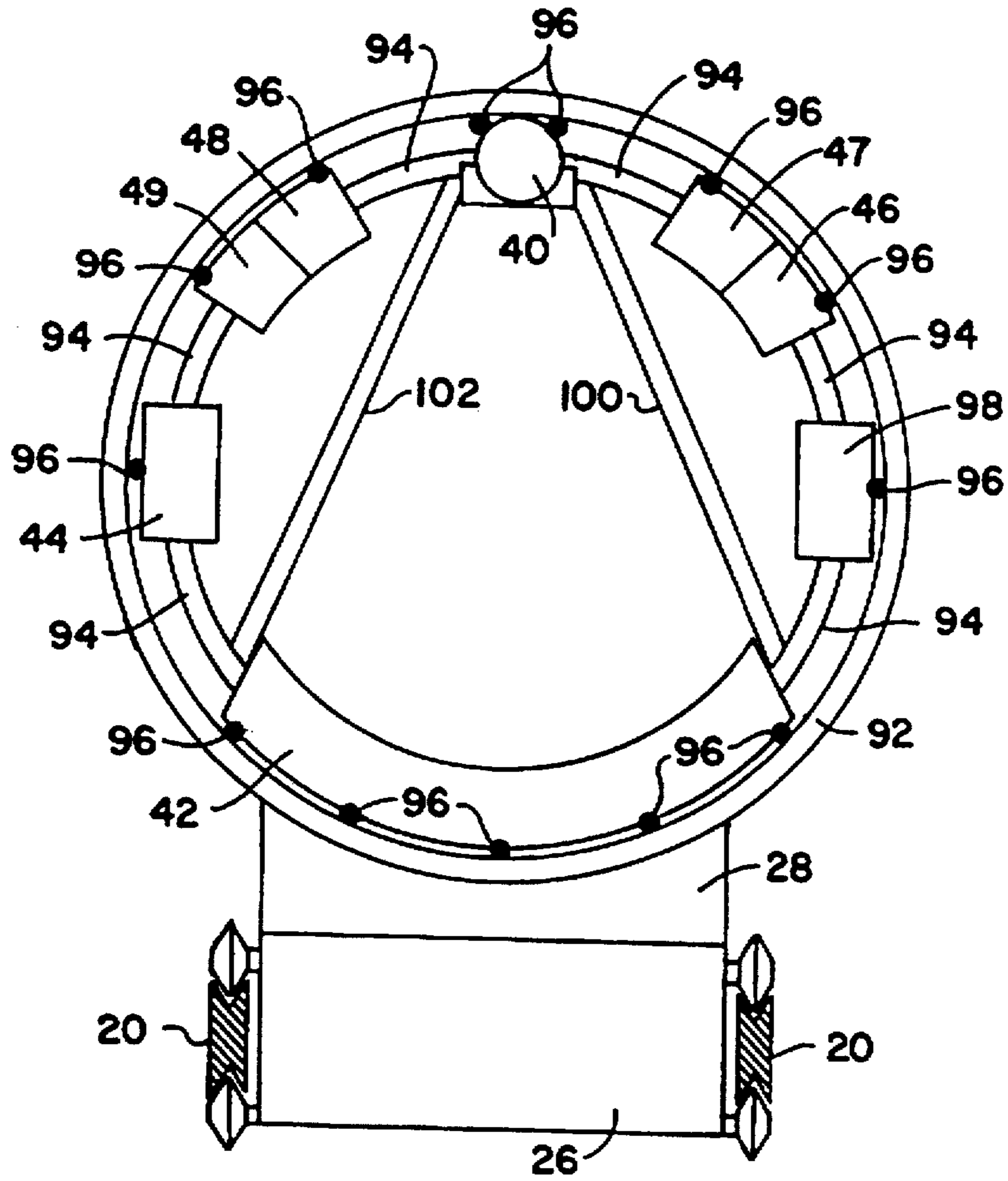

Fig. 4

X-RAY TOMOGRAPHY APPARATUS

Matter enclosed in heavy brackets [] appears in the original patent but forms no part of this reissue specification; matter printed in italics indicates the additions made by reissue.

[This application is a reissue application for U.S. Pat. No. 4,928,283, based on U.S. Ser. No. 160,657, filed Feb. 26, 1988 by Bernard M. Gordon.] *This application is a continuation of reissue application Ser. No. 07/744,112, filed Aug. 9, 1991, and now U.S. Pat. No. Re. 34,379 reissued Sep. 14, 1993, the latter being based upon original U.S. Pat. No. 4,928,283, issued May 22, 1990. Additional divisional reissue applications filed on Jul. 19, 1994, are as follows: U.S. Ser. No. 08/277,337; U.S. Ser. No. 08/277,496; and U.S. Ser. No. 08/277,331; all of which have been abandoned.*

BACKGROUND OF THE INVENTION

1. Field of the Invention

The present invention generally relates to x-ray tomography apparatuses and, in particular, to those apparatuses which are adapted for CAT scan operations.

2. Statement of the Prior Art

CAT scans (computerized axial tomography) have been used for many years. Generally the system operates by taking multiple, cross-sectional, slice x-rays from different angles within a single plane passing through the body. The results are mathematically compiled to create a cross-sectional image of the body in that plane. To produce these x-rays in one form, an x-ray source and an array of detectors are placed on opposite sides of an annular yoke, which yoke is made to rotate within the selected plane and around the patient.

An important condition in scanning has been the accurate and consistent alignment of the tomography components and the patient both throughout the rotation and over the course of many scans and patients. Misalignment or movement can negatively influence the data of an entire scan. In order to deal with this factor, manufacturers of CAT scan apparatuses have typically produced a very large and massive machine which includes a heavy yoke for mounting the tomography components. The handling of this weight requires additional mass in the remainder of the apparatus and typically a large apparatus.

One ramification of the extra size and mass of these machines has been the requirement of a patient handling apparatus, as the weight of the patient is typically much less than the weight of the yoke and other rotating components. Thus, a moveable patient table has been used to properly position the patient in the desired location relative to the fixed yoke, and this further contributes to the size and weight of the apparatus.

A further contributor to the size and mass of these machines has been the problem of delivering electrical power for the x-ray source to the rotating apparatus. The two approaches primarily used have been electrical brushes, or slip rings, which constantly sweep during rotation and extended cables which limit the rotation of the yoke to approximately one revolution. Unfortunately, the brush approach creates a disruptive amount of electrical interference in the very sensitive output signals of the detectors. Some of this interference can be reduced by the use of shielding; however, the shielding must be extensive as the brushes rotate around the entire large circumference of the yoke. The shielding also adds bulk and weight. More accurate machines use the extended cables which limit rotation.

Unfortunately, this approach requires much larger motors and produces greater system stresses and wear, because the yoke and all of the of the moving mass must be accelerated and decelerated quickly in order to adequately operate within the limited rotational range of the yoke.

The apparatus which results from these various requirements is large, heavy, expensive and one which is difficult to relocate. It requires a large amount of floor space and thus cannot be used in space limited environments. A further disadvantage caused by the size and weight of these apparatuses is the wear experienced in the moving parts thereof.

In another form of tomography apparatus known in the prior art, the x-ray source and an array of detectors are mounted on a "C" shaped frame which is typically cantilevered and manipulated over the patient. Although this apparatus can be manipulated over a wide range, it also requires large amounts of space and mass for the manipulation apparatus.

SUMMARY OF THE INVENTION

Accordingly, the present invention provides a tomography apparatus which has a substantially reduced size and mass for enabling a high degree of mobility for the apparatus while requiring a much smaller amount of space for the installation. An x-ray tomography apparatus provides a patient table means, x-ray tomography means located around the patient table means and in an imaginary plane which intersects the table means, and means for supporting the table means and tomography means and including means for moving the tomography means along at least a portion of the table means. In an alternate embodiment, an x-ray tomography apparatus includes an annular x-ray tomography means for continuously rotating around a patient, which means has an electrically powered x-ray source and battery powered means for supplying electrical power to the x-ray source.

The various tomography means of the present invention may be combined with several optional features which further enhance the size, weight, cost and independent movement of the tomography means both rotatively around the patient and otherwise. These optional features includes means for determining the relative position between the patient table means and the tomography means to allow alignment error to be calculated into the data compilation, a non-uniform detector configuration to reduce the number of detector channels used, and means for providing wireless transmission of the tomography data.

BRIEF DESCRIPTION OF THE DRAWINGS

The present invention is illustratively described with respect to the accompanying drawings in which:

FIG. 1 is a perspective view of an x-ray tomography apparatus constructed in accordance with one embodiment of the present invention;

FIG. 2 is a perspective view of a different orientation of the apparatus of FIG. 1;

FIG. 3 is a sectional view of the apparatus of FIG. 1 taken along view lines 2—2; and

FIG. 4 is a side view of an alternative embodiment of a portion of the apparatus of FIG. 1.

DETAILED DESCRIPTION OF THE DRAWINGS

FIG. 1 shows an x-ray tomography apparatus 10 generally including a patient table 12, a tomography apparatus 14, and a support structure 16 for the table 12 and the tomography

apparatus 14. The patient table 12 is intended to be removable from the support structure 16. Support structure 16 may take any suitable form capable of performing the functions described herein. As shown, structure 16 includes four vertical support members or legs 18 connected to a floor bracket 19 including side members 20 and end members 22.

Also included in the support structure 16 is a cradle 24 for supporting the tomography means 14. Cradle 24 includes a lower cradle member 26 and an upper cradle member 28. Lower cradle member 26 is supported at each end thereof by the side members 20 of the support structure 16. This support is provided through bearing surfaces 30 to allow the support means 24 and the tomography means 14 to be moved at least a portion of the length of the patient table 12. To effect this movement, a drive means 32 is coupled between end members 22 and engages the lower cradle member 26. Drive means 32 may comprise any means capable of moving the cradle and tomography means 14 the required distances. One suitable means would be a worm gear engaging a portion of the lower cradle member 26. Another would be a drive belt. In a preferred embodiment the drive means 32 is adapted to move the tomography means the entire length of the table 12. This would allow the apparatus to be used in an operating room setting where the tomography means 14 would be stored at a patients feet when not in use and thus not be in the way of surgeons or the anesthetist.

Cradle 24 is constructed with upper member 28 rotatably mounted to lower member 26 to enable upper member 28, and therefore the tomography means 14, to be rotated to a position parallel with the length of the table as shown in FIG. 2, for enabling easier transportation of the apparatus 10. To further this function, a pair of removable support blocks 34 are mounted on drive means 32 to steady the tomography apparatus in the transport position. Also, the legs 18 may be stiffened by diagonal members (not shown) affixed to the end members 22, and wheels may also be mounted to the floor bracket 19. During transport the table 12 would be removed from the support 16 and the tomography means 14 would be turned to the position shown in FIG. 2 which is substantially parallel to the length of the support 16.

FIG. 1 also shows means 33 for determining the position of the tomography means 14 with respect to the table 12. This function may be performed by an suitable means such as some form of optical measurement system. The system may be mounted on the tomography means 14 at 33 shown in FIG. 1 and make reference to the table 12, or it may be mounted on the table 12 and make reference to the tomography means 14. Special measurement markings or indicia may also be mounted on either the tomography means 14 or table 12 for reference to by the system. The measurement system could provide information on both the angular position of the tomography means 14 and any misalignment thereof within the rotational plane. All of this information can be used in compiling images from the scan data. Thusly, misalignments during the scan could be used to provide more scan data for the construction of images because they would reduce the amount of duplicate data collected during the scan.

FIG. 3 is a sectional view of the apparatus of FIG. 1 taken along view line 3—3 and showing greater detail of the tomography means 14. Whereas the tomography means 14 may have various covers affixed thereto for providing a more esthetic apparatus, the would be covers are removed in FIG. 3 to allow a representational showing of the instrumentation. Tomography means 14 is shown to include a number of tomography components including an x-ray source 40, an

array of detectors 42, a control and data handling electronics package 44, a source of power for the x-ray source 40 including batteries 46 and a power converter 47, and a source of power for the electronics package 44 including batteries 48 and a power converter 49. It is anticipated that the tomography means 14 will have a patient opening or inner diameter of approximately 65 to 70 centimeters and an outer diameter of approximately 125 to 140 centimeters.

X-ray source 40 provides for the electrical generation of x-rays by methods well known in the art. In a preferred embodiment the x-ray source 40 is adapted for continuous operation during a scanning operation. This technique of scanning is referred to as Continuous Wave Fan Beam Tomography and is described in greater detail in U.S. Pat. No. 4,547,893, assigned to Analogic Corporation of Peabody, Mass. This technique reduces the signal processing electronics necessary with attendant cost and weight savings. X-ray source 40 would also include a collimator for determining the x-ray fan beam and means for dissipating excess heat generated in the production of the x-rays.

The electronics package 44 provides for data handling from the detectors 42 and for control of the x-ray process. This control is provided via a two-way communication link between the electronics package 44 and a computer 50 used for image processing and control. This two-way communication link may be achieved by any suitable means. Further, the control and image processing methods which may be used by computer 50 are well known in the CAT scanning art.

Power for the x-ray source 40 and for the data handling electronics package 44 is provided from the batteries 46 and 48 and the power converters 47 and 49, respectively. These power converters 47, 49 provide the voltages necessary for the respective equipment which they power. Power converter 47 is a high-voltage supply and power converter 49 is a low voltage supply. Whenever the tomography means 14 is brought to the rest position in between scans, shown in FIG. 3, a pair of electrical contacts 52 may be used to recharge the batteries 46 and 48 in order to allow pseudo-continuous operation of the CAT scan. These contacts 52 are shown to be connected to the batteries 46 and 48 via electrical lines 54. Converters 47, 49 would also include means for dissipating excess heat generated in the conversion process.

The detector array 42 includes three sections of detectors 56 and 58. The section 56 is located about a center line 60 which passes through the x-ray source 40 and through the center of rotation 62 of the tomography means 14. The section 56 of detectors is substantially centered on either side of the center line 60, with perhaps a small offset to avoid symmetry about the center line 60 for providing greater amounts of collected data. The x-rays which strike the detectors within section 56 radiate along the radial lines located between radial lines 64 and 66 passing from the x-ray source 40 to the detector array 42. The other sections 58 of detectors are located adjacent to the section 56 and are intended to receive x-ray information for x-rays radiating between the radial lines 66 and 68, 64 and 70 from the source 40. Thusly, energy is only radiated from the source 40 within the fan beam 72 located between radia lines 68 and 70.

The purpose of having two groups of detectors concerns the informational content of the x-rays being detected. Within the radial lines 64 and 66 are typically located all of the major organs and complex structure of the human body. The body structure located between radial lines 66 and 68,

64 and 70 is typically much simpler and does not encompass vital organs. Therefore the informational content of the x-rays between lines 64 and 66 is greater and more important than the informational content of the x-rays between lines 66 and 68, 64 and 70. For this reason, it is permissible to construct an array of detectors which has higher detector density in the section 56 and a lower detector density in the section 58. This allows a reduction, and therefore a cost and weight savings, in the number of detectors and the associated electronics used where the information to be collected simply is not present. In lieu of and/or in combination with varying detector densities, it may be desirable to sample the outer detectors 58 at a lower rate than the inner detectors 56. It may also be desirable to have more than two groups of detectors having different detector densities and/or sampling rates. This technique is discussed in greater detail in U.S. Pat. No. 4,677,554, also assigned to Analogic Corporation.

It should be noted that it is possible to construct the tomography means 14 without having any detectors located to the left of section 56. When the tomography means 14 is in the position shown in FIG. 3, data is not collected for those portions of the body 74 which lie to the left of radial line 6. Those portions 74 of the body are x-rayed as the tomography means 14 rotates through other angular positions with respect to the patient. Again, because this outer portion 74 contains no vital organs, the data to be collected therefrom is less significant and the structure can be imaged by using less data collection. The elimination of this additional section of detectors enables further weight and cost savings for the x-ray apparatus.

Also shown in FIG. 3 are means for rotatably supporting and for rotating the tomography means 14. Any suitable means may be used for this purpose. Nominally shown in FIG. 3 are roller bearings 80 and a drive belt apparatus 82. These means are capable of continuously rotating the tomography means 14 without stopping to collect data for individual scans. Continuous rotation enables the use of the Continuous Wave Fan Beam Tomography technique referred to above. Continuous rotation is possible because the tomography means is designed and constructed to be electrically independent. It is anticipated that the tomography means 14 will rotate at a speed of approximately one revolution every 4 to 5 seconds or 12 to 15 revolutions per minute.

FIG. 4 shows an alternate embodiment 90 of tomography means 14 with the addition of a circular frame or track 92 which is stationary and surrounds the tomography components. The tomography components are both connected and held apart by a multiplicity of hollow separators 94 through which electrical cables are run. The separators 94 are used to physically bias the component apart and thus outwardly against the track 92. The components engage the track 92 by means of wheels 96. The track 92 thereby helps to provide rigidity to the tomography mean 90.

Further disclosed in FIG. 4 as one of the tomography components is a means 98 for rotating the tomography means 90 within the circular track 92. This means 98 is an electrically powered locomotive means which might be powered by its own internal battery or any other suitable means. Locomotive means 98 engages the track 92 by any suitable means such as a gear-and-tooth arrangement, and similar to the tomography means of FIG. 3, enables continuous rotation thereof. The remainder of the components of tomography means 90 of FIG. 3 are identical to those of the tomography means 14 of FIG. 3.

Also included as part of the structure of the tomography means 14 are a pair of triangularly placed support members

100 and 102. The upper ends of members 100 and 102 are coupled to the x-ray source 40, preferably at a single coupling point (not shown). The lower ends of members 100 and 102 are connected to opposite ends of the detector array 42. The detector array 42 is mounted on a rigid structure so that the ends thereof do not move with respect to one another. The distances between the ends of the detector array 42 and the x-ray source describe a triangle which may either be equilateral or have an angle greater than 60 degrees at the corner of x-ray source 40. The equilateral triangle would provide the most clearance for the patient and table 12 if the sides of the triangle were straight. Because the detector array 42 is arcuate a non-equilateral triangle may be used. Thus, the members 100 and 102 and detector array 42 form a pseudo-triangular structure for significantly enhancing the rigidity of the tomography means 90. This arrangement helps to provide both the proper alignment between the x-ray source 40 and the detector array 42 and also lends significant rigidity to the annular shape of the tomography means 90 which might otherwise be distorted during rotation.

METHOD OF OPERATION

During scanning of a patient, the apparatus of the present invention may be operated in any one of several modes. The most typical mode of operation would be to locate the tomography means 14 along the patient table 12 by use of the drive means 32 at the desired position with respect to a patient located on the table 12. This may be accomplished by visual reference to the patient. When the tomography means 14 is properly located, it is rotated to perform a set of scans in accordance with the continuous wave tomography method. Signals to perform this scan are transmitted from the computer 50 to the electronics package 44, which then takes control of the operation.

The present apparatus may also be used to produce a simple x-ray of a patient in what may be termed a scout mode. To accomplish this, the tomography apparatus 14 is not rotated but moved along the table 12 while the x-raying is performed. The data collected from this operation is used to produce a normal x-ray of the patient, such as that which might be used to determine the general location of specific organs and other points. As the fan beam of x-rays shown in FIG. 3 does not cover the entire patient, and in particular the portion 74, it would simply be necessary to rotate tomography means 14 until the width of the fan beam at the center of rotation 62 were sufficient to encompass the entire body prior to performing the scout scan of the patient. Such simple x-rays may also be effected by scanning the patient twice, first with the position of the tomography means shown in FIG. 3, and then again with the tomography means 14 inverted to cover the portion 78 of the patient. This method would produce an enhanced image for the area covered by detector section 56.

Lastly, it is possible to perform a helical scan of the patient by simultaneously rotating the tomography means 14 and moving it along the patient table 12. This scanning method allows three dimensional data to be collected, from which data it would be mathematically possible to construct an image for any slice through the scanned volume. Thus a patient's head could be scanned as a volume and the radiologist would have available any image of the head that he or she might want. This would avoid the necessity of bringing a patient back for additional x-rays when more information is desired.

The embodiments of the present invention described are intended to be taken in an illustrative and not a limiting

sense. Various modifications and changes may be made to these embodiments by persons skilled in the art without departing from the scope of the present invention as defined in the appended claims.

What is claimed is:

1. An x-ray tomography apparatus, comprising:
 an elongated patient table means having opposite ends;
 a rotary fan beam x-ray tomography means encircling the patient table means; and
 means for supporting the table means at opposite ends thereof and for supporting the tomography means from underneath and including means for moving the tomography means along a substantial portion of the table means,

wherein the tomography means includes means for causing at least a portion of the tomography means to continuously rotate around the table means.]

2. [The] An x-ray tomography apparatus [of claim 1.] comprising:

*an elongated patient table means having opposite ends;
 a rotary fan beam x-ray tomography means encircling the patient table means; and*

means for supporting the table means and means for supporting the tomography means, said means for supporting the tomography means including means for moving the tomography means along a substantial portion of the table means,

wherein the tomography means includes means for causing at least a portion of the tomography means to continuously rotate around the table means;

wherein the tomography means comprises a multiplicity of members including an x-ray source, an array of detectors, tomography electronics and at least one means for supplying electrical power for the tomography means.

3. The apparatus of claim 2, further comprising means for physically interconnecting the members of the tomography means in an annular shape for rotation around the table means.

4. The apparatus of claim 3, wherein the tomography means further includes triangularly placed structural members affixed between the x-ray source and the array of detectors.

5. The apparatus of claim 4, wherein the array of detectors includes a support member which extends between the triangularly placed structural members.

6. The apparatus of claim 2, further comprising means for transmitting control and data signals to and from the tomography means.

7. The apparatus of claim 2, wherein the means for supplying electrical power are battery powered.

8. The apparatus of claim 2, wherein the rotation of the tomography means defines a center of rotation thereof and further wherein the array of detectors includes at least first and second groups of detectors with the first group being substantially centered about an imaginary line passing through the x-ray source and the center of rotation and the second group being located adjacently to the first group.

9. The apparatus of claim 8, wherein the first group of detectors has a higher average detector density than the second group.

10. [The] An x-ray tomography apparatus [of claim 1.] comprising:

*an elongated patient table means having opposite ends;
 a rotary fan beam x-ray tomography means encircling the patient table means; and*

means for supporting the table means and means for supporting the tomography means, said means for supporting the tomography means including means for moving the tomography means along a substantial portion of the table means,

wherein the tomography means includes means for causing at least a portion of the tomography means to continuously rotate around the table means;

further comprising means for determining the relative position between the tomography means and the patient table means.

11. [The] An x-ray tomography apparatus [of claim 1.] comprising:

*an elongated patient table means having opposite ends;
 a rotary fan beam x-ray tomography means encircling the patient table means; and*

means for supporting the table means and means for supporting the tomography means, said means for supporting the tomography means including means for moving the tomography means along a substantial portion of the table means,

wherein the tomography means includes means for causing at least a portion of the tomography means to continuously rotate around the table means;

wherein the means for supporting the table means is elongated and the table means is removable from the means for supporting, and further wherein the means for supporting the tomography means includes means for allowing orientation of the tomography means to a position where an imaginary plane of rotation defined by the rotating portion of the tomography means is substantially parallel with the elongated means for supporting.

12. An X-ray tomography apparatus comprising in combination: a support structure for supporting an elongated patient table; tomographic scanning means also supported on said support structure, said scanning means including an X-ray source and X-ray detection means for detecting X-rays emitted by said X-ray source; means for rotating said scanning means about a rotation axis so as to circumscribe an inner region large enough to encompass said patient table with a patient thereon; and, means for pivoting said scanning means between a first position wherein said scanning means is rotatable so as to define a scanning plane substantially normal to the elongated direction of said table, and a second position wherein said plane is substantially parallel to said elongated direction.

13. The apparatus of claim 12, further comprising means for supporting said scanning means for linear movement along a path substantially parallel to the elongated direction of said patient table.

14. The apparatus of claim 13, further comprising means for supporting said patient table so that the latter extends through said inner region when said scanning means is in said first position, said means for supporting including a base and means coupled to said base for removably supporting said patient table thereon, said scanning means being mounted on said base so that when said patient table is removed, said scanning means is pivotable with respect to said base between said first and second positions without hindrance from said table or means for supporting said table.

15. The apparatus of claim 14, wherein said scanning means is pivotable about said base so that the orientation of said scanning plane can be varied with respect to the elongated direction of said table.

16. The apparatus of claim 15, further comprising means for determining the relative alignment of said scanning plane with said table.

17. The apparatus of claim 12, further comprises means for physically interconnecting the members of the tomography scanning means in an annular shape for rotation around the table.

18. The apparatus of claim 12, further comprising battery means for powering said apparatus.

19. The apparatus of claim 18, wherein said battery means comprise rechargeable batteries.

20. An X-ray tomography apparatus comprising in combination:

(a) x-ray tomography means disposed in an annular configuration so as to define a scanning region large enough to accommodate a patient and a movable patient table;

(b) patient table support means for supporting a movable patient table having a head end and a foot end within said scanning region, said patient table support means comprising a support structure and at least one vertical support member;

(c) tomography support means supported by said support structure for supporting said tomography means for linear movement along an axis running between the head end and the foot end of said patient table and for pivoting said tomography means between a first position wherein the plane of said annular configuration is substantially normal to said axis and a second position wherein the plane is substantially parallel to said axis; and

(d) tomography rotation means for orbital movement of said tomography means around said scanning region.

21. The apparatus of claim 20, further comprising battery means for powering said apparatus.

22. The apparatus of claim 21, wherein said battery means comprise rechargeable batteries.

23. The apparatus of claim 20, wherein said patient table support means comprise a plurality of vertical support members attached to said support structure at their lower ends and adapted to support said patient table at their upper ends.

24. The apparatus of claim 23, wherein said support members define an open, box-like region for at least partially accommodating said tomography means when it is in said second position.

25. An X-ray tomography apparatus for use with an elongated patient table, said apparatus comprising, in combination:

tomographic scanning means, said scanning means including an X-ray source and X-ray detection means for detecting X-rays emitted by said X-ray source;

means for rotating said tomographic scanning means about a rotation axis so as to circumscribe an inner region large enough to encompass said patient table with a patient thereon;

support means for supporting said tomography means; and

means for pivoting said scanning means, relative to said support means about a substantially vertical axis between a first, scanning position wherein said scanning means can be used to scan a patient on the patient table, and a second, transport position wherein said apparatus can be more easily transported.

26. In an X-ray tomography apparatus comprising in combination

tomographic scanning means including (i) an X-ray source and (ii) X-ray detection means for detecting X-rays emitted by said X-ray source;

means for rotating at least the X-ray source about a rotation axis; and

battery means for powering said X-ray source.

27. The apparatus of claim 26, wherein said battery means comprise rechargeable batteries.

28. The apparatus of claim 26, wherein said means for detecting X-rays includes means for data handling, wherein said means for data handling is also powered by said battery means.

29. In an X-ray tomography apparatus of the type comprising:

an X-ray source for generating X-rays during a tomographic scan;

X-ray detection means for detecting X-rays emitted by said X-ray source during a tomographic scan;

tomographic scanning means for rotating at least the X-ray source about a scanned object during a tomographic scan; and

self-contained, rechargeable, power storage means for storing sufficient energy for powering said x-ray source during at least one complete tomographic scan so that the use of an external power supply is unnecessary for powering said X-ray source during said scan.

30. The tomography apparatus according to claim 29, wherein said apparatus further includes data handling means for handling data representative of X-rays detected by said X-ray detection means, and said power storage means is adapted to store sufficient additional energy so as to also power said data handling means during a tomographic scan.

31. The tomography apparatus according to claim 29, wherein said power storage means is carried by said tomographic scanning means so as to rotate therewith during a tomographic scan.

32. The tomography apparatus according to claim 29, wherein said power storage means comprises rechargeable batteries.

33. The tomography apparatus according to claim 29, wherein said apparatus further comprises an elongated patient table; and means for supporting said tomographic scanning means relative to said patient table so that said scanning means is movable relative to said patient table along a path substantially parallel to the elongated direction of said patient table.

34. The tomography apparatus according to claim 33, further comprising means for supporting said tomographic scanning means relative to said patient table so that said scanning means is rotatable about a rotation axis while said scanning means moves relative to said patient table along said path so as to permit helical scanning about said rotation axis.

35. The tomography apparatus according to claim 29, wherein said tomographic scanning means is continuously rotatable about a rotation axis during a tomographic scan.

36. An X-ray tomography apparatus comprising

(a) an X-ray source;

(b) X-ray detection means for detecting X-rays emitted by said X-ray source during a tomographic scan and for generating data representative of image data acquired during said tomographic scan;

(c) tomographic scanning means for supporting at least said X-ray source;

(d) support means for supporting said tomographic scanning means so that said tomographic scanning means

is movable relative to said support means during a tomographic scan; and

(e) communication means including first communication means fixed relative to said tomographic scanning means and second communication means fixed relative to said support means, for establishing a wireless communication link between said first communication means and said second communication means so as to permit in use wireless transmission of said data therebetween.

37. The tomography apparatus according to claim 36, further comprising control means for controlling said X-ray source, and wherein said first and second communication means in use connects said control means and said X-ray source so that said X-ray source can be controlled through said wireless communication link by said control means.

38. The tomography apparatus according to claim 36, wherein said tomographic scanning means is rotatable about a rotation axis relative to said support means during a tomographic scan; said tomographic scanning means being further movable in the direction of said rotation axis while rotating about said rotation axis so as to provide in use a helical scan about said rotation axis.

39. The tomography apparatus according to claim 36, further including rechargeable power storage means, coupled to said X-ray source, for storing sufficient power and for supplying said power to said X-ray source so as to perform at least one tomographic scan so that the use of an external power supply is unnecessary for powering said X-ray source during said scan.

40. An X-ray tomography apparatus comprising

(a) an X-ray source;

(b) X-ray detection means for providing data representative of X-rays detected by said detection means during a tomographic scan;

(c) tomographic scanning means for supporting at least said X-ray source;

(d) support means for supporting said tomographic scanning means so that said tomographic scanning means is movable relative to said support means during a tomographic scan, and

(e) wireless link communication means for establishing a wireless communication link over which data relating to a tomographic scan can be transmitted, said wireless communication means including

(i) data transmitting means, coupled to said X-ray detection means, for transmitting over said wireless communication link data received from said X-ray detection means, and

(ii) data receiving means for receiving from said communication link data transmitted by said data transmitting means over said link.

41. In an X-ray tomography apparatus of the type comprising:

(a) an X-ray source;

(b) X-ray detection means for detecting X-rays emitted by said X-ray source and for providing data representative of the detected X-rays during a tomographic scan;

(c) tomographic scanning means for supporting at least the X-ray source;

(d) support means for supporting said tomographic scanning means so that said tomographic scanning means is movable relative to said support means during a tomographic scan; and

communication means for establishing a two-way wireless communication link so that data relating to said tomographic scan can be transmitted over said link.

42. The tomography apparatus according to claim 41, wherein said communication means includes data transmitting means coupled to said X-ray detection means, for transmitting data received from said X-ray detection means; and data receiving means for receiving said data over said link from said data transmitting means so as to produce images based upon said data.

43. The tomography apparatus according to claim 41, further including data control means for generating control data for controlling the X-ray source, means for transmitting said control data over said link, and data receiving means, coupled to said X-ray source, for receiving said control data from said link and for controlling said X-ray source with said control data.

44. An X-ray tomography apparatus comprising

(a) a X-ray source means for providing a source of X-rays during a tomographic scan;

(b) X-ray detection means for detecting X-rays emitted by said X-ray source during a tomographic scan;

(c) tomographic scanning means for supporting at least said X-ray source means;

(d) support means for supporting said tomographic scanning means so that said tomographic scanning means is movable relative to said support means during a tomographic scan;

(e) means for processing data relating to a tomographic scan, and

(f) communication means for establishing a two-way wireless communication link between said means for processing data and each of said X-ray source means and said X-ray detection means so as to permit in use the transmission of data therebetween.

45. The tomography apparatus according to claim 44, wherein said means for processing data is fixed relative to said support means.

46. The tomography apparatus according to claim 44, wherein the means for processing data is adapted to control the X-ray source means, the communication means in use connecting through said link the X-ray source means and the means for processing data.

47. The tomography apparatus according to claim 44, wherein the X-ray detection means provides data representative of X-rays detected by the detection means during a tomographic scan, and said communication means further includes

(i) data transmitting means, coupled to said X-ray detection means, for transmitting data, received from said X-ray detection means, over said link, and

(ii) receiver means for receiving said transmitted data from said link so as to permit the production of images based upon said data.

48. The tomography apparatus according to claim 47, wherein said X-ray detection means and said data transmitting means are fixed relative to said tomographic scanning means, and said data receiving means is fixed relative to said support means.

49. The tomography apparatus according to claim 48, further including control means for controlling said X-ray source means, wherein said receiving means is adapted to also transmit data, and said transmitting means is adapted to also receive data so that said control means is controlled by data transmitted over said link.

50. In an X-ray tomography apparatus of the type comprising

- (a) an X-ray source;
- (b) X-ray detection means for detecting X-rays emitted by said X-ray source;
- (c) tomographic scanning means for supporting at least said X-ray source; and
- (d) support means for supporting said tomographic scanning means so that said scanning means is rotatable about a rotation axis during a tomographic scan; wherein the improvement comprises:

means for moving said tomographic scanning means along said rotation axis during a scan so that said tomographic scanning means provides a helical scan about said rotation axis.

51. The tomography apparatus according to claim 50, further including a patient table and table support means for supporting said patient table so that the patient table remains fixed relative to said support means, and the tomographic scanning means moves relative to said table so as to provide a helical scan about the patient table during a tomographic scan.

* * * * *