



US00RE35312E

**United States Patent** [19]  
**Christoudias**

[11] E

**Patent Number: Re. 35,312**

[45] **Reissued Date of Patent: Aug. 6, 1996**

[54] **CHRISTOUDIAS ENDOSPONGESTICK PROBE**

[75] Inventor: **George C. Christoudias**, New Milford, N.J.

[73] Assignee: **Surgical Inventions & Innovations, Inc.**, New Milford, N.J.

5,002,556	3/1991	Ishida et al.	606/192
5,030,227	7/1991	Rosenbluth et al.	606/104
5,074,840	12/1991	Yoon	604/11
5,269,753	12/1993	Wilk	606/192
5,286,261	2/1994	Roizenblatt	606/192
5,309,896	5/1994	Moll et al.	606/192
5,359,995	11/1994	Sewell	606/192

**FOREIGN PATENT DOCUMENTS**

[21] Appl. No.: **327,404**

2006019	5/1979	United Kingdom	606/192
8606611	11/1986	WIPO	606/192

[22] Filed: **Oct. 21, 1994**

**Related U.S. Patent Documents**

Reissue of:

[64] Patent No.: **5,188,630**  
 Issued: **Feb. 23, 1993**  
 Appl. No.: **674,470**  
 Filed: **Mar. 25, 1991**

[51] Int. Cl.<sup>6</sup> ..... **A61B 17/00**  
 [52] U.S. Cl. .... **600/207; 606/108; 604/1**  
 [58] Field of Search ..... 606/1, 108, 191,  
 606/200; 604/1, 11, 96, 104, 158, 171,  
 264, 265, 358; 600/201, 204, 207

[56] **References Cited**

**U.S. PATENT DOCUMENTS**

1,909,967	5/1933	Jones	604/1
3,882,852	5/1975	Sinnreich	606/92
3,978,863	9/1976	Fettel et al.	606/194
3,996,938	12/1976	Clark, III	606/192
4,198,981	4/1980	Sinnreich	606/193
4,921,484	5/1990	Hillstead	606/194
4,969,890	11/1990	Sugita	606/192
4,993,412	2/1991	Murphy-Chutorian	606/194

*Primary Examiner*—Stephen C. Pellegrino  
*Assistant Examiner*—Glenn Dawson  
*Attorney, Agent, or Firm*—Richard A. Joel

[57] **ABSTRACT**

A spongystick for *retraction, and tissue manipulation in* endoscopic procedures including a hollow stem of substantially cylindrical cross-section with a longitudinal groove along its outer surface and having a handle at one end and a balloon receptor portion at the other end. The stem is surrounded by a retractable sheath having a handle at the end adjacent the stem handle. A balloon system comprises a Leur lock tip at its upper end for coupling to inflation means and an elongated tube portion which extends within the longitudinal groove in the stem to a tubular balloon which fits over the receptor portion. Circumferential grooves are provided on the upper and lower sections of the receptor portion to accommodate rubber bands which secure a tubular gauze member over the balloon. The gauze member is expanded by inflation of the balloon *during use*. The hollow interior of the stem provides a passage for endoscopic instruments such as forceps, dissectors, etc.

**14 Claims, 3 Drawing Sheets**

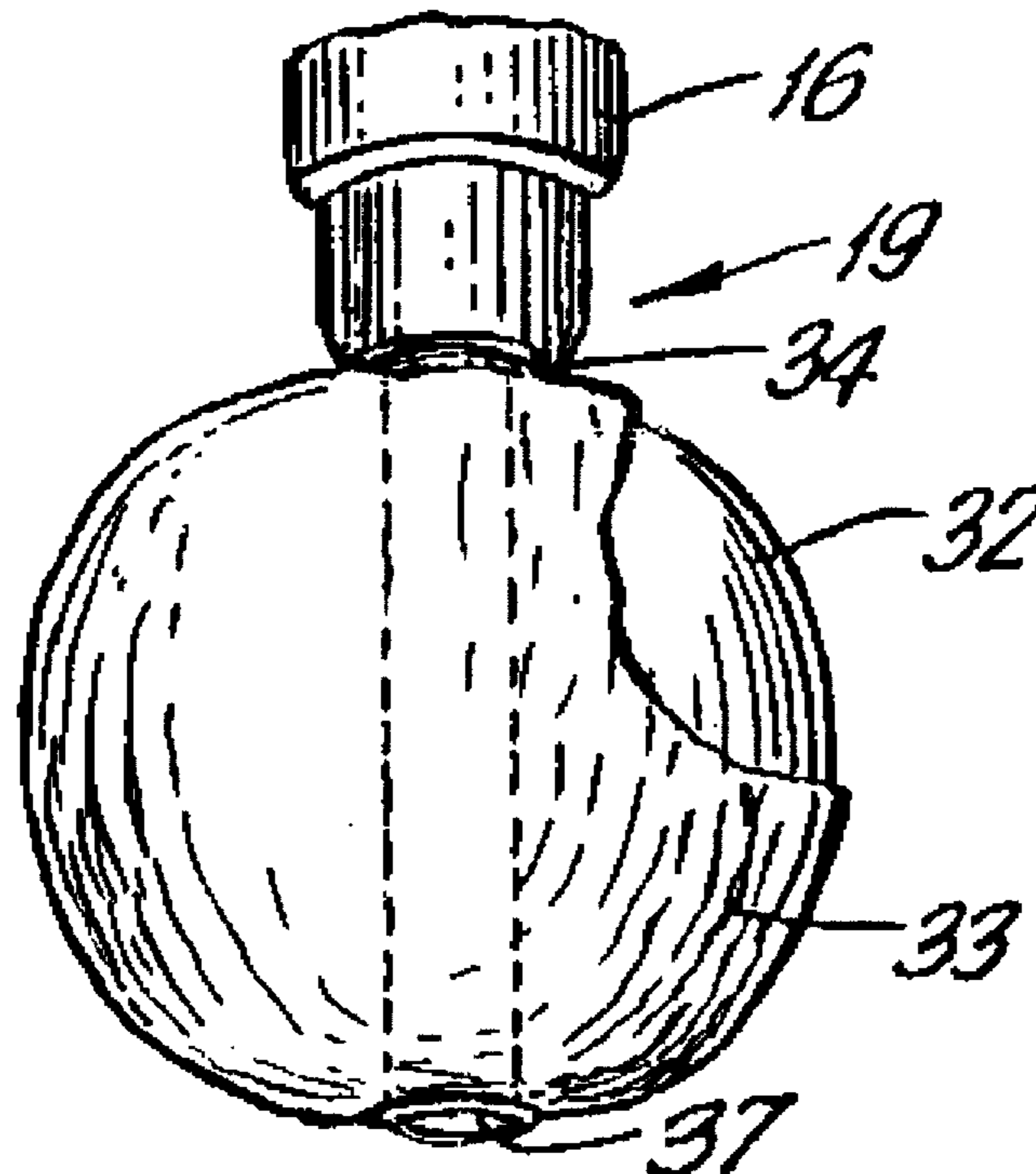

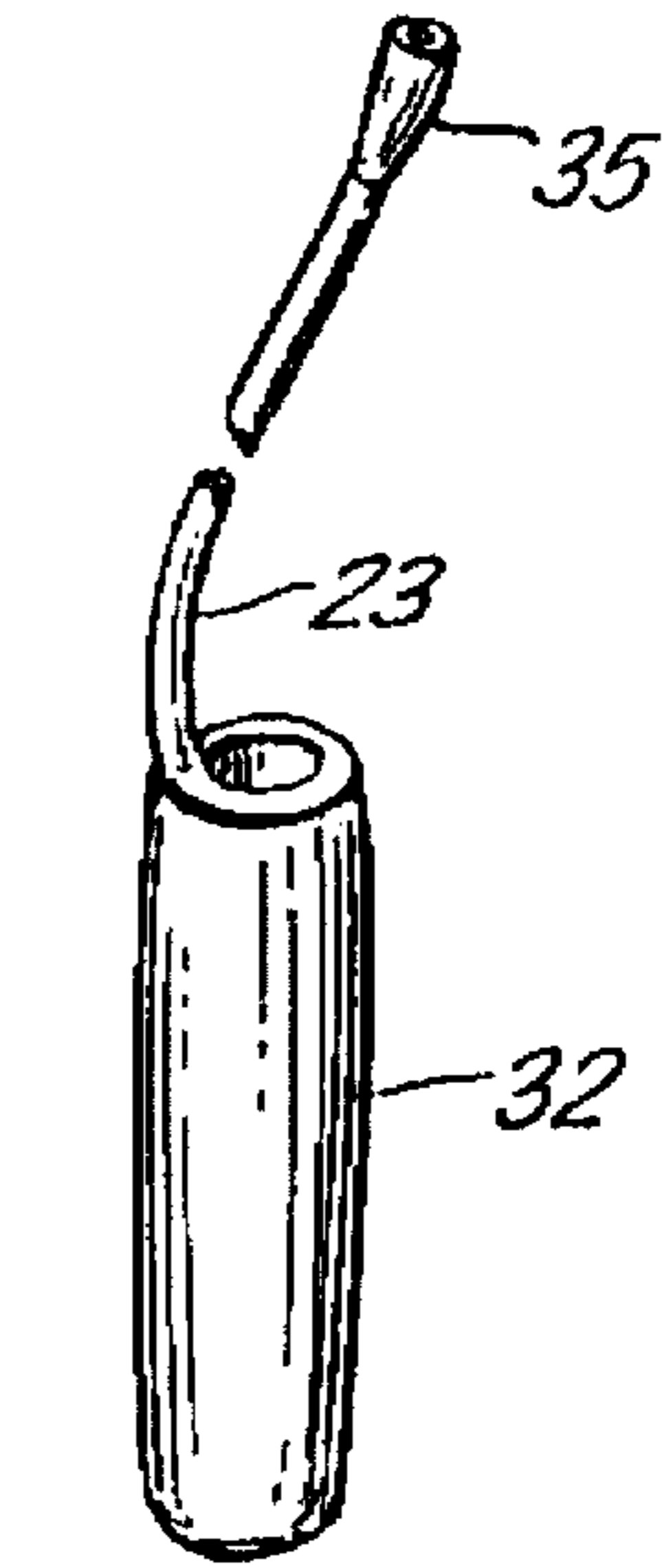
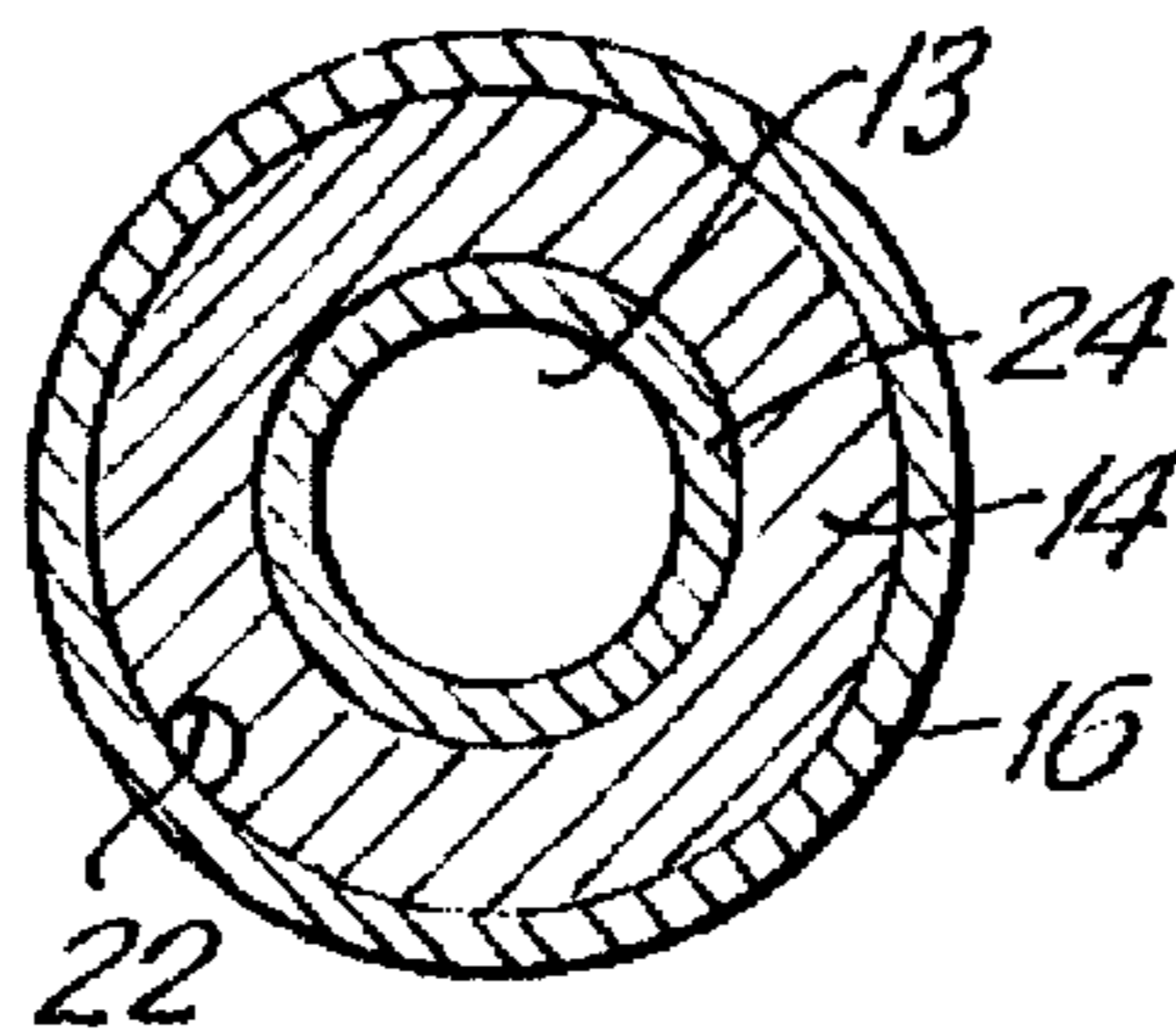
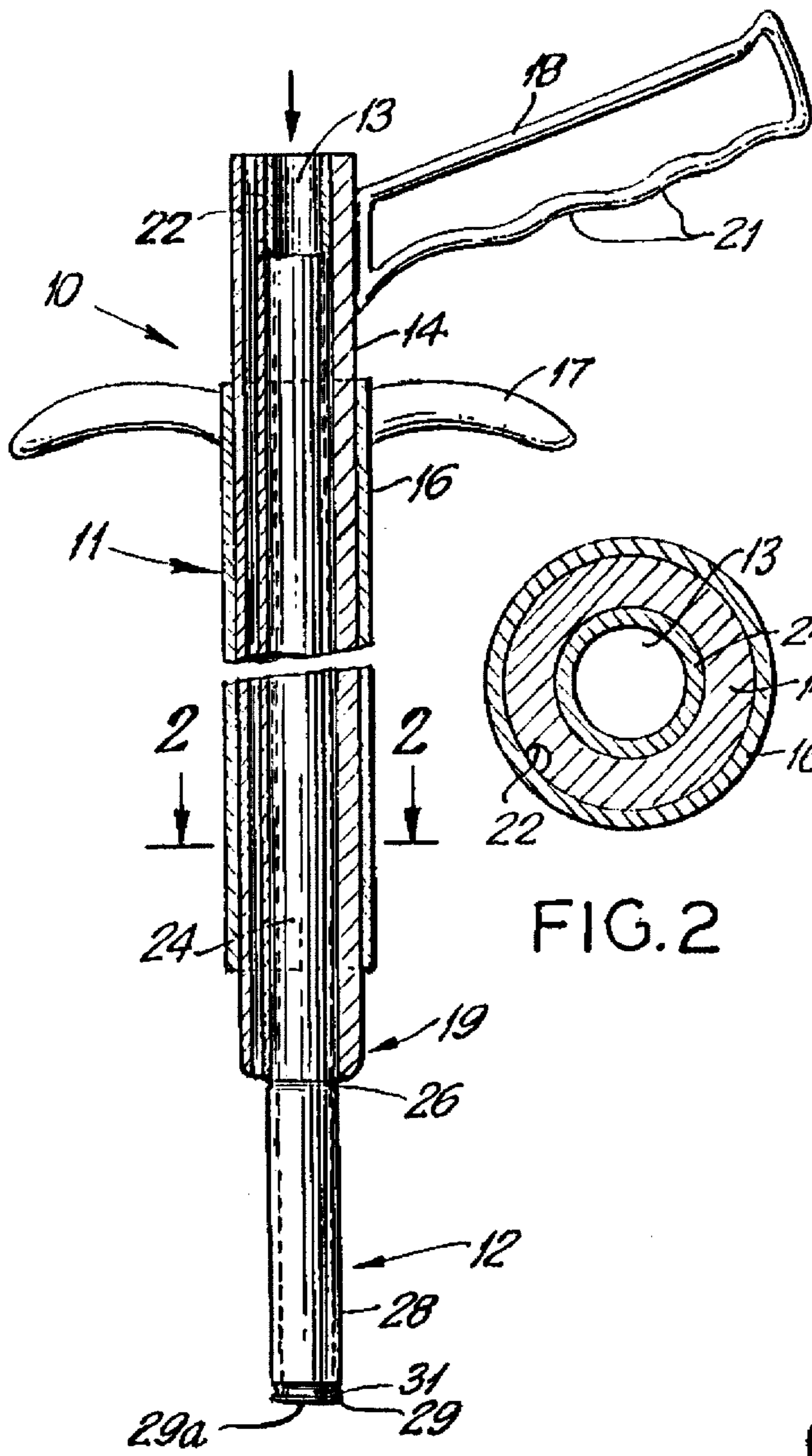

FIG. 3

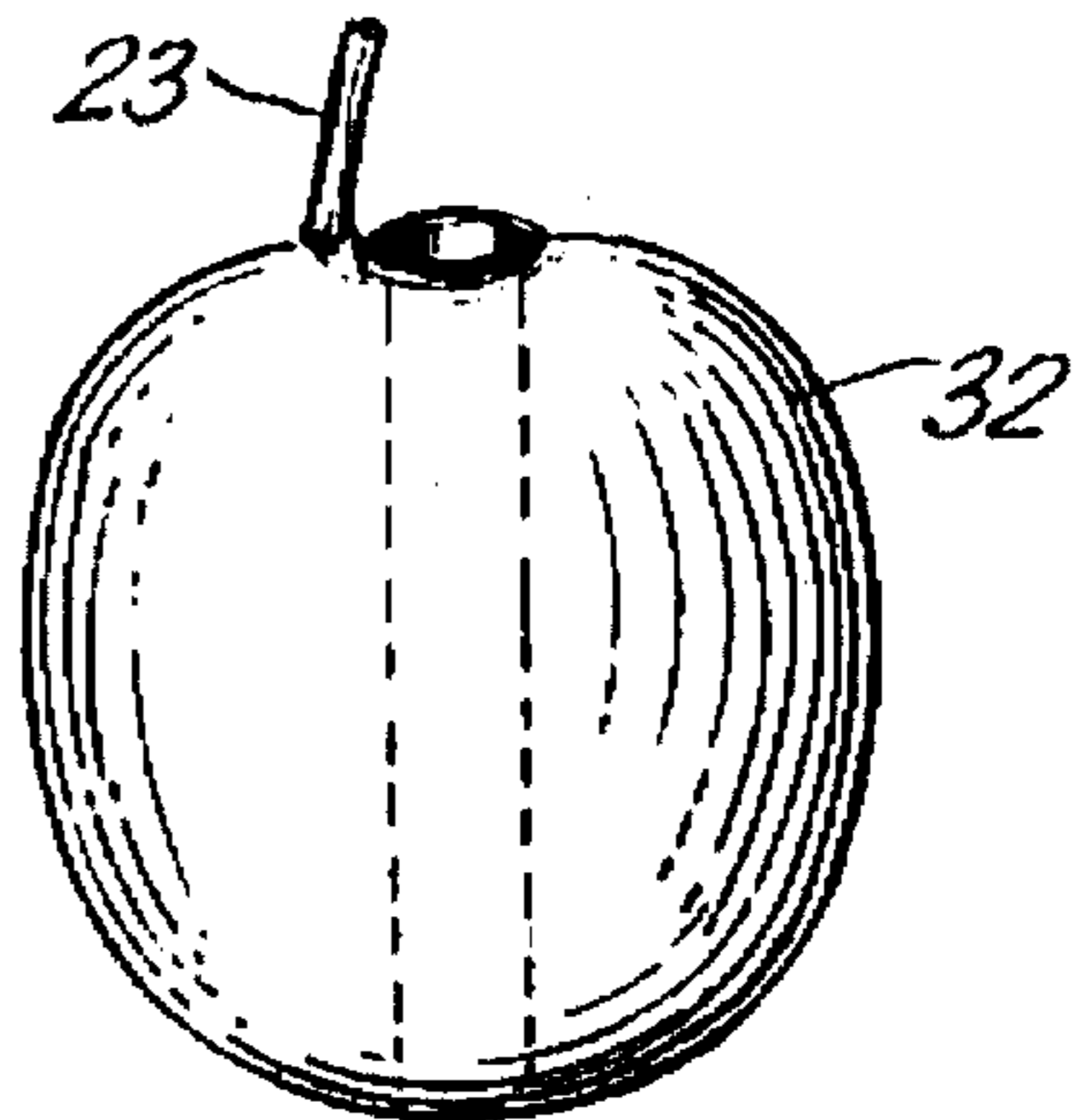

FIG. 4

FIG. 1

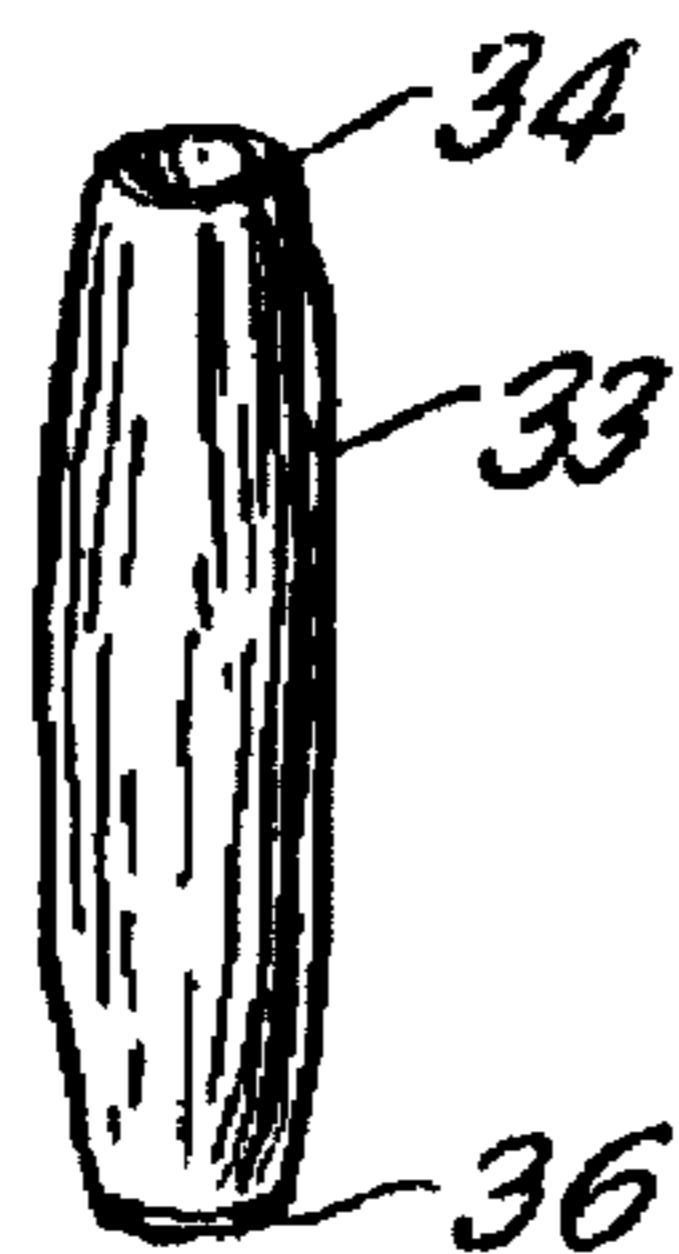

FIG. 5

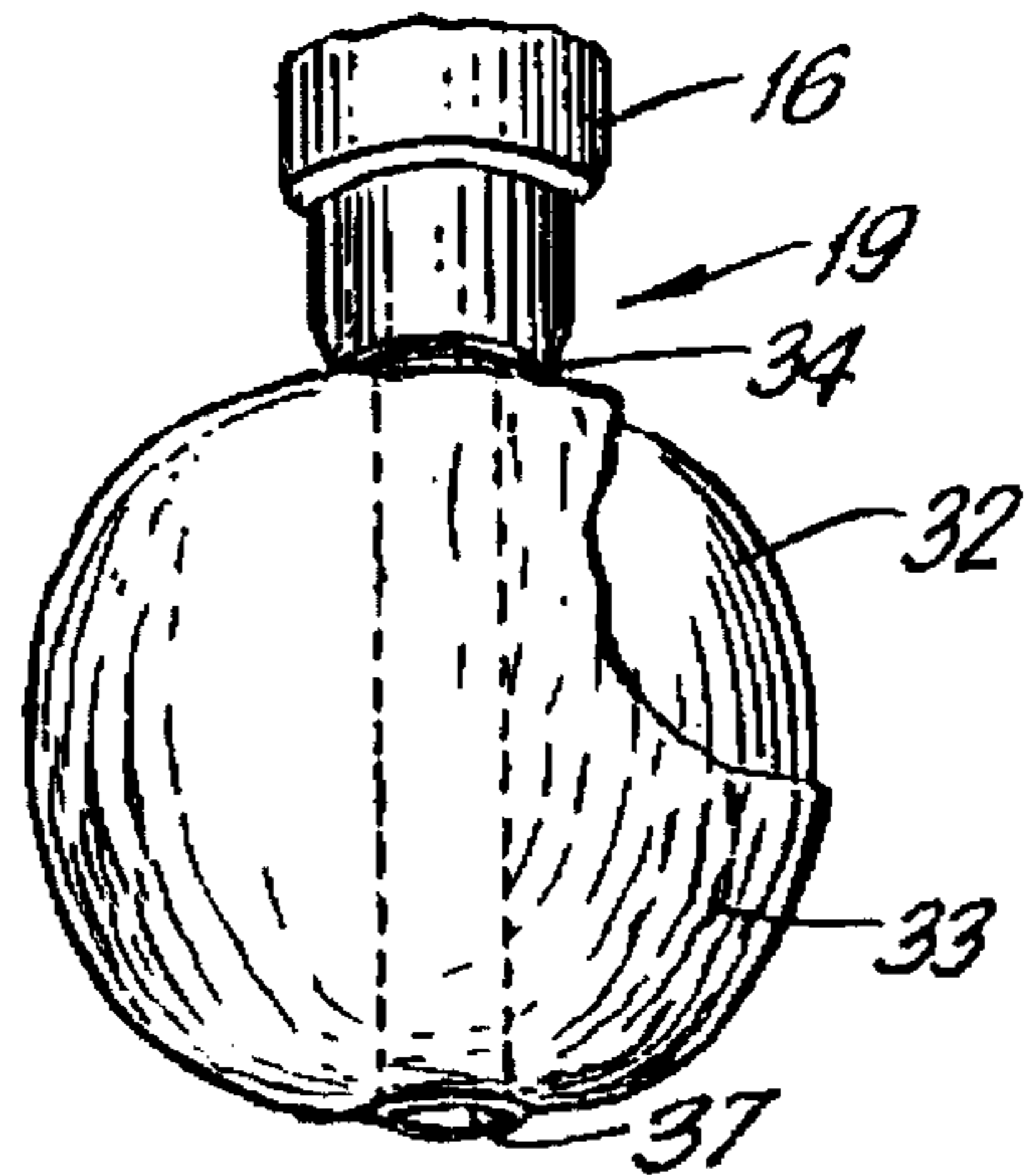

FIG. 6

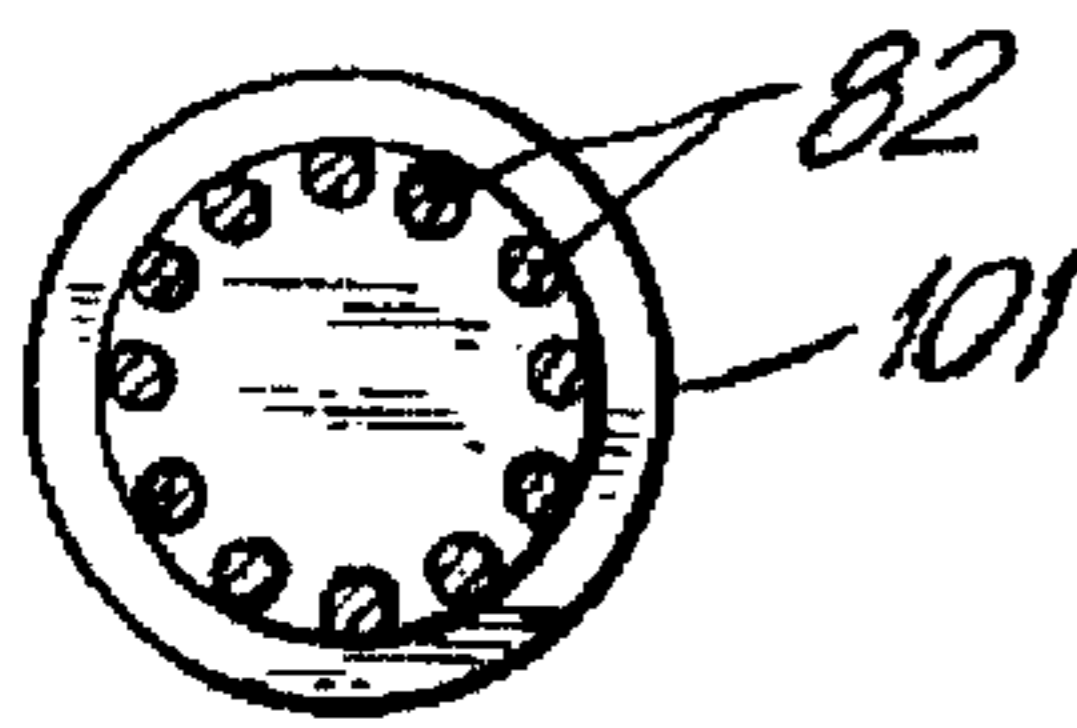

FIG. 15

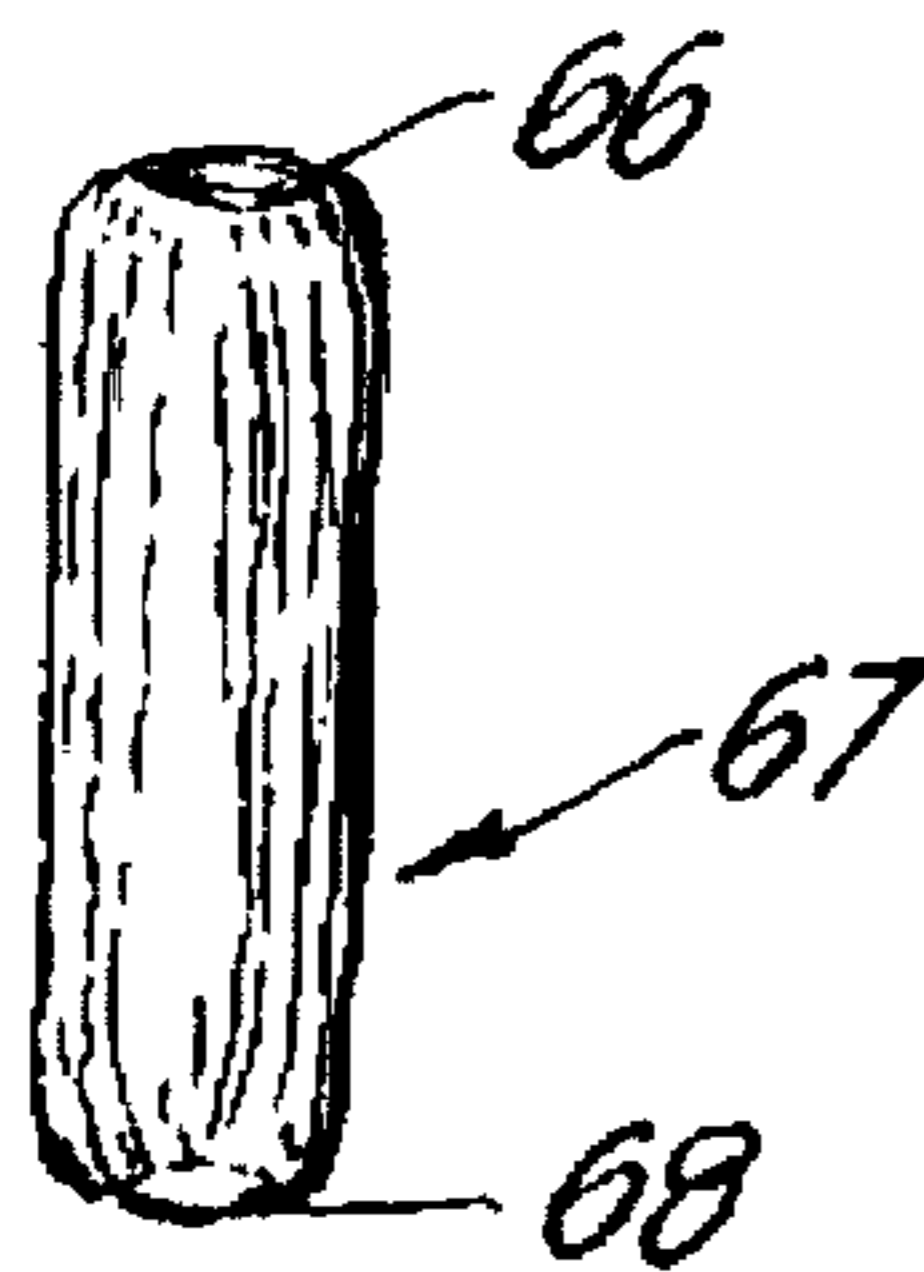

FIG. 9

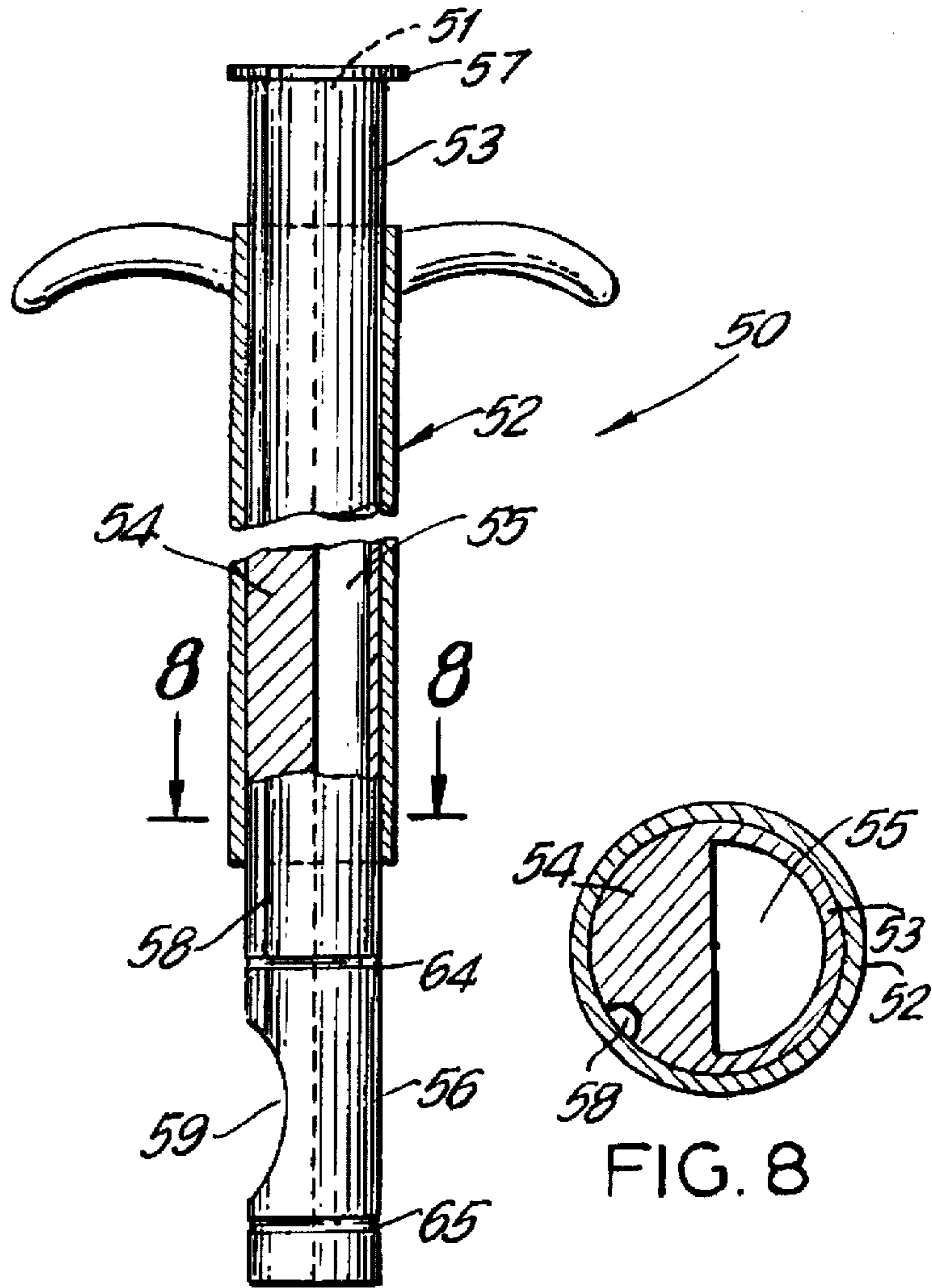

FIG. 7

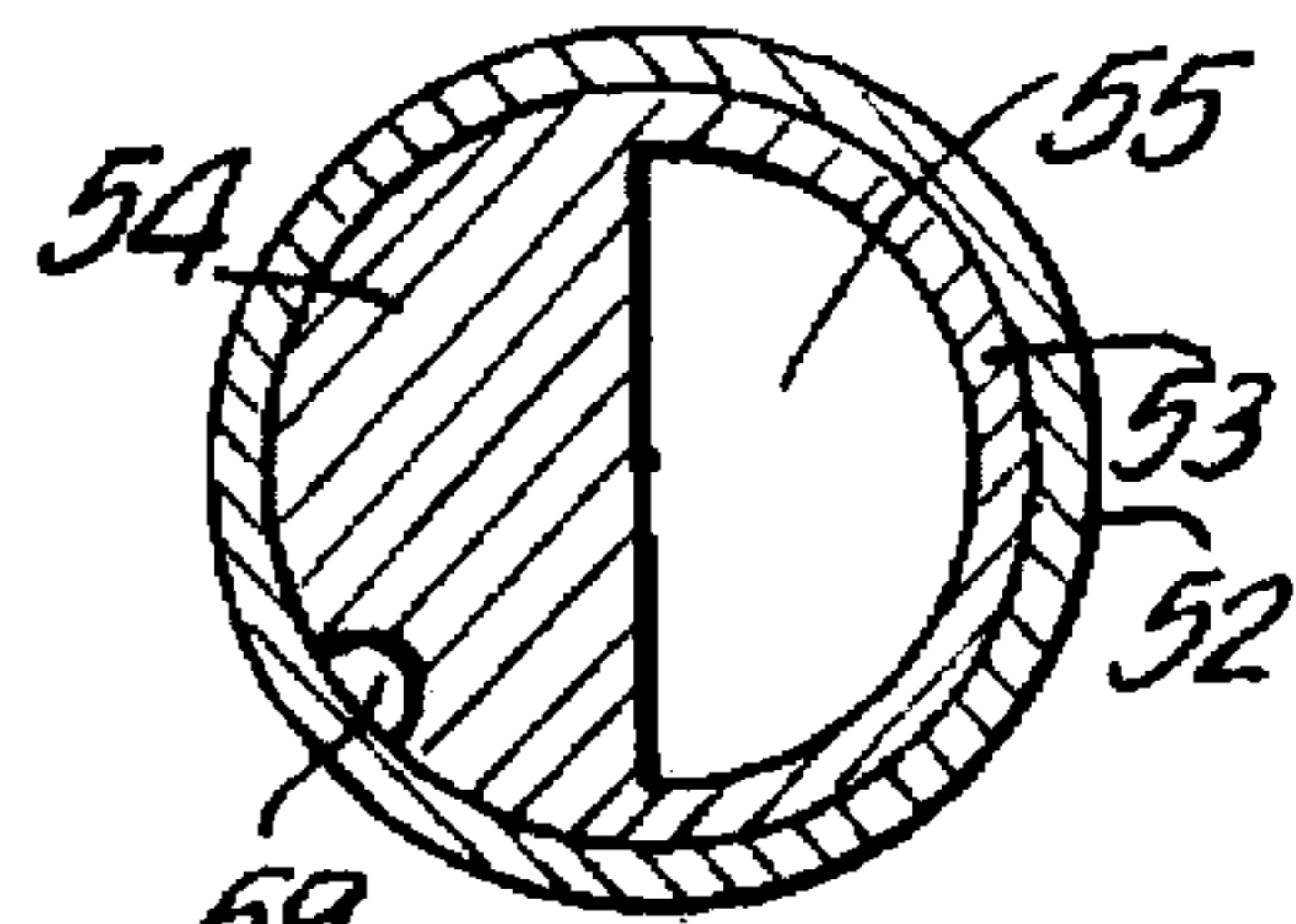

FIG. 8

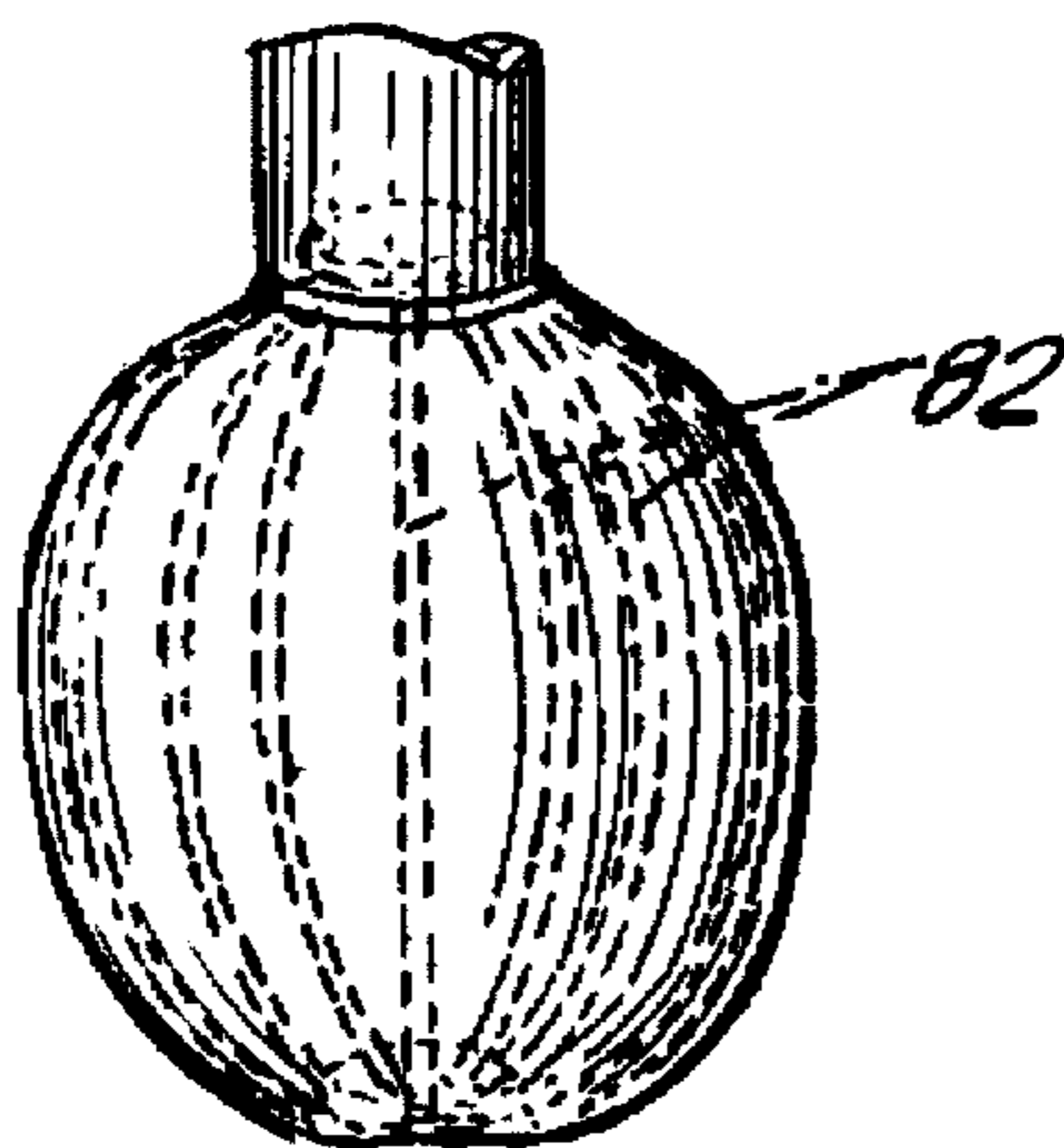

FIG. 16

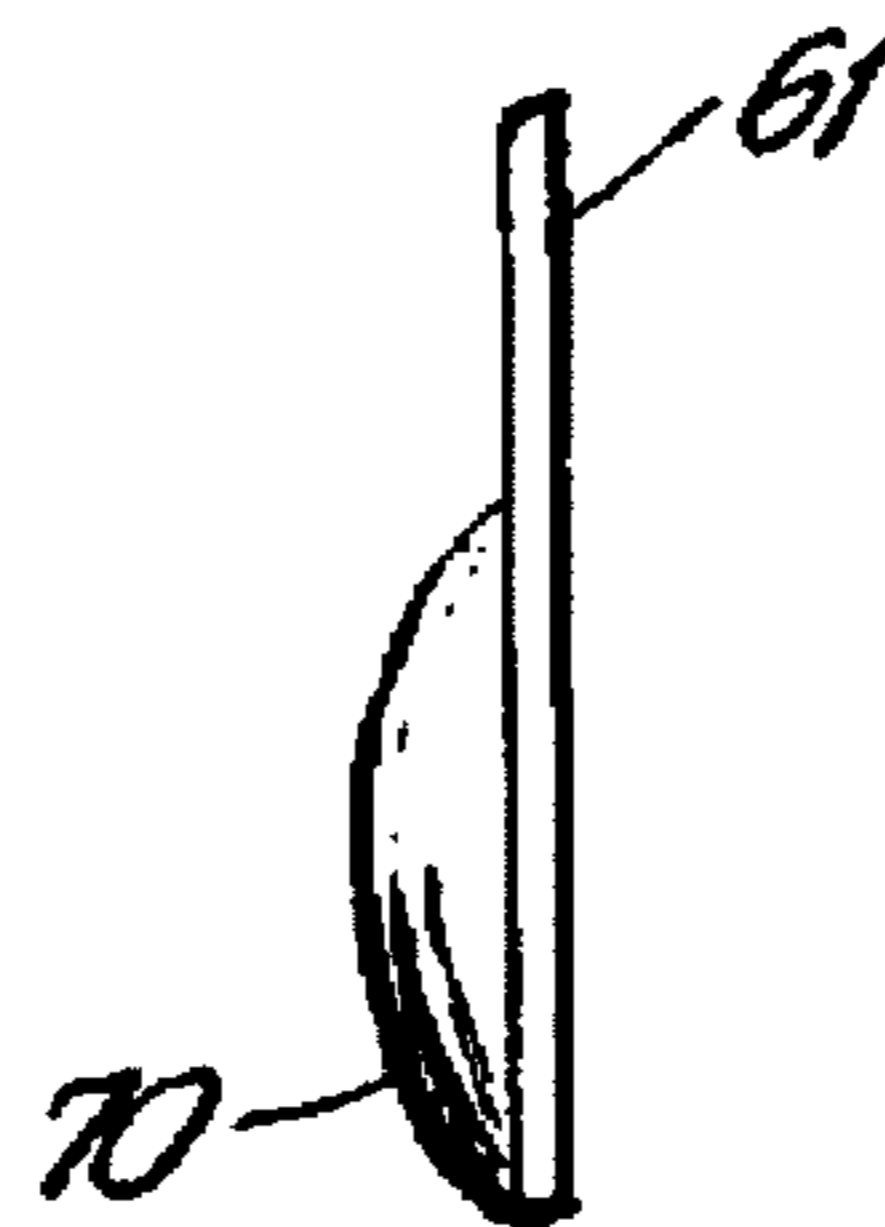

FIG. 10a

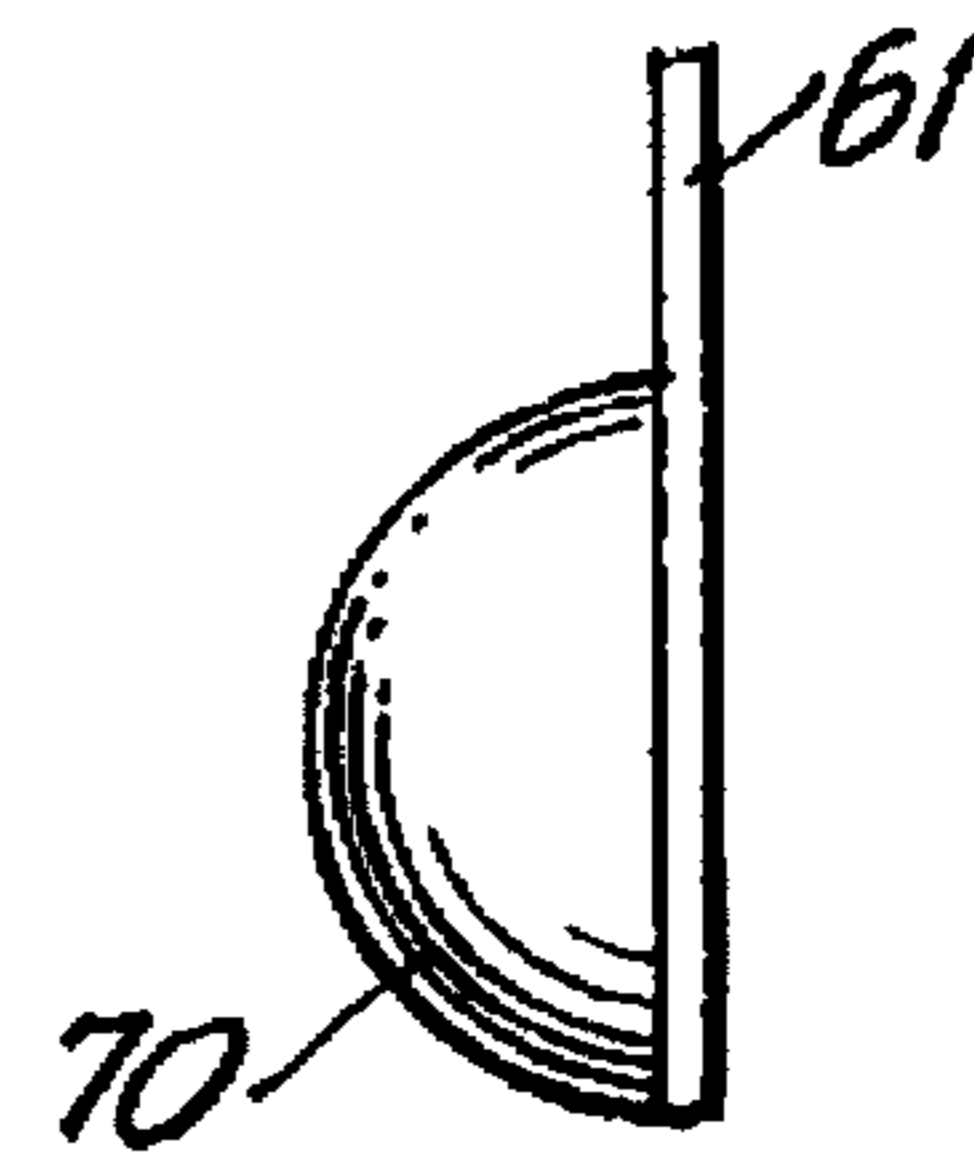

FIG. 10b

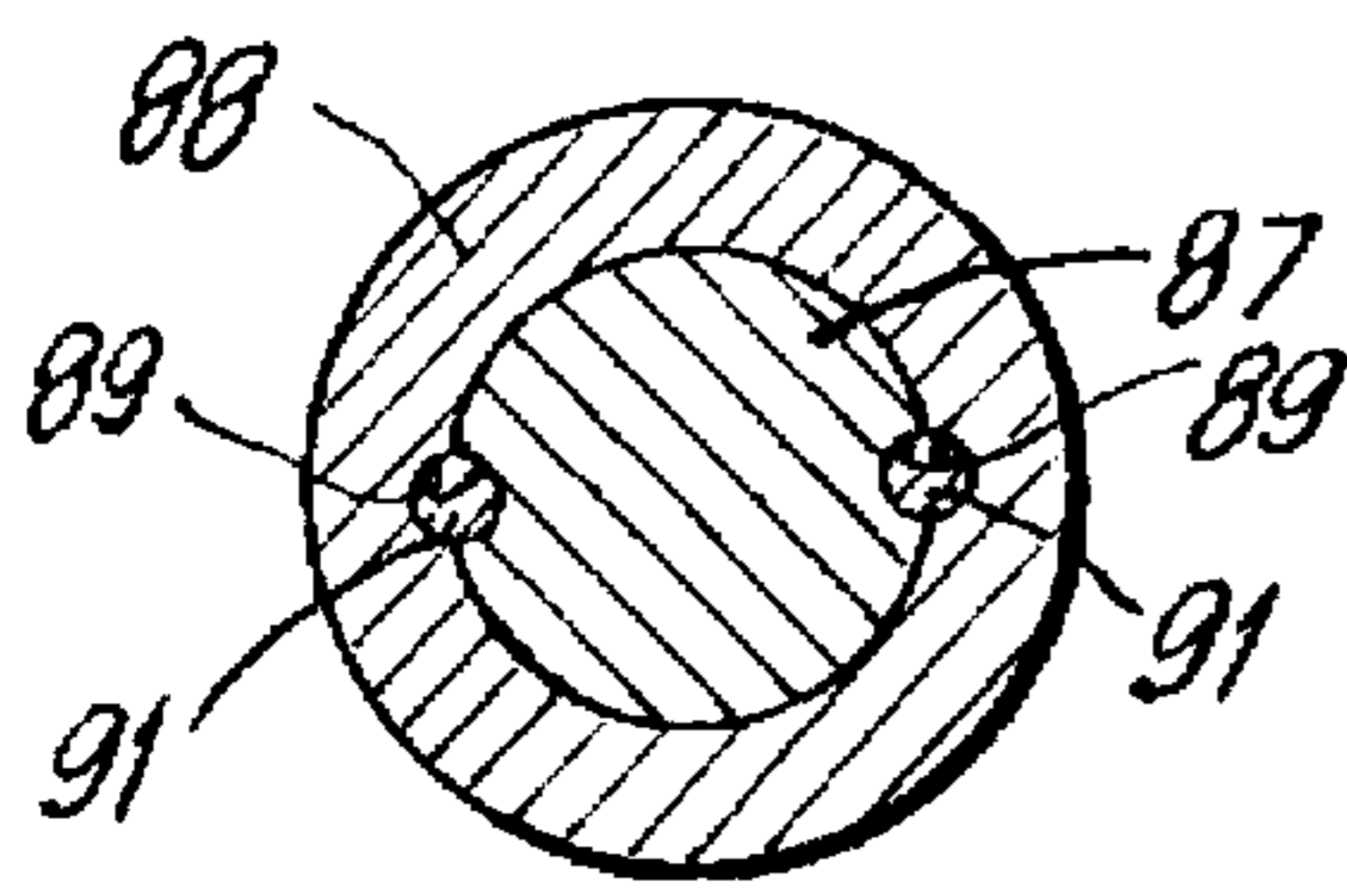

FIG. 13

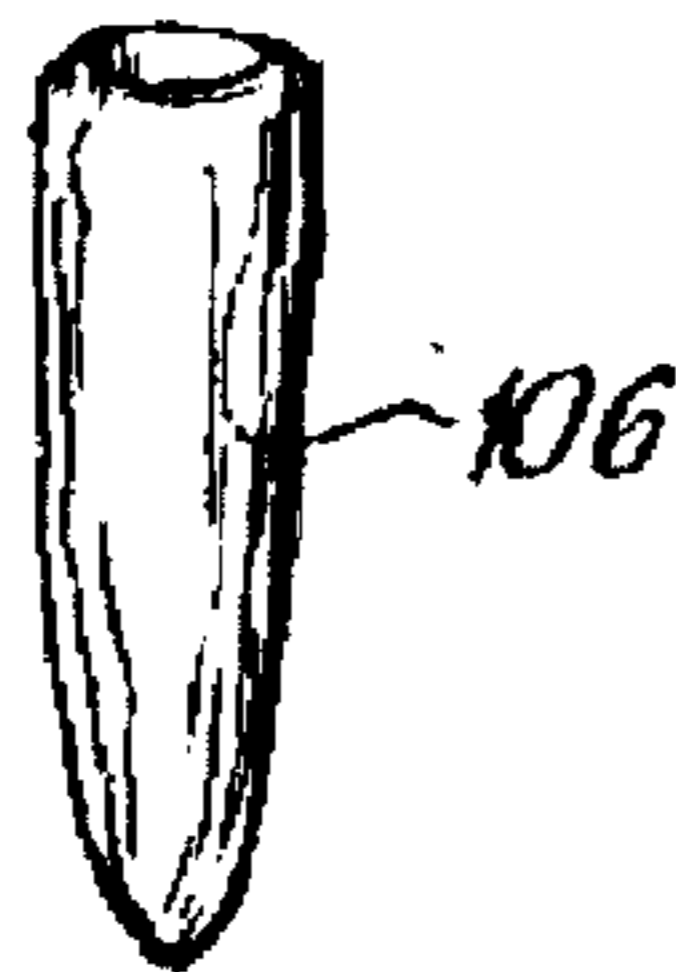

FIG. 18

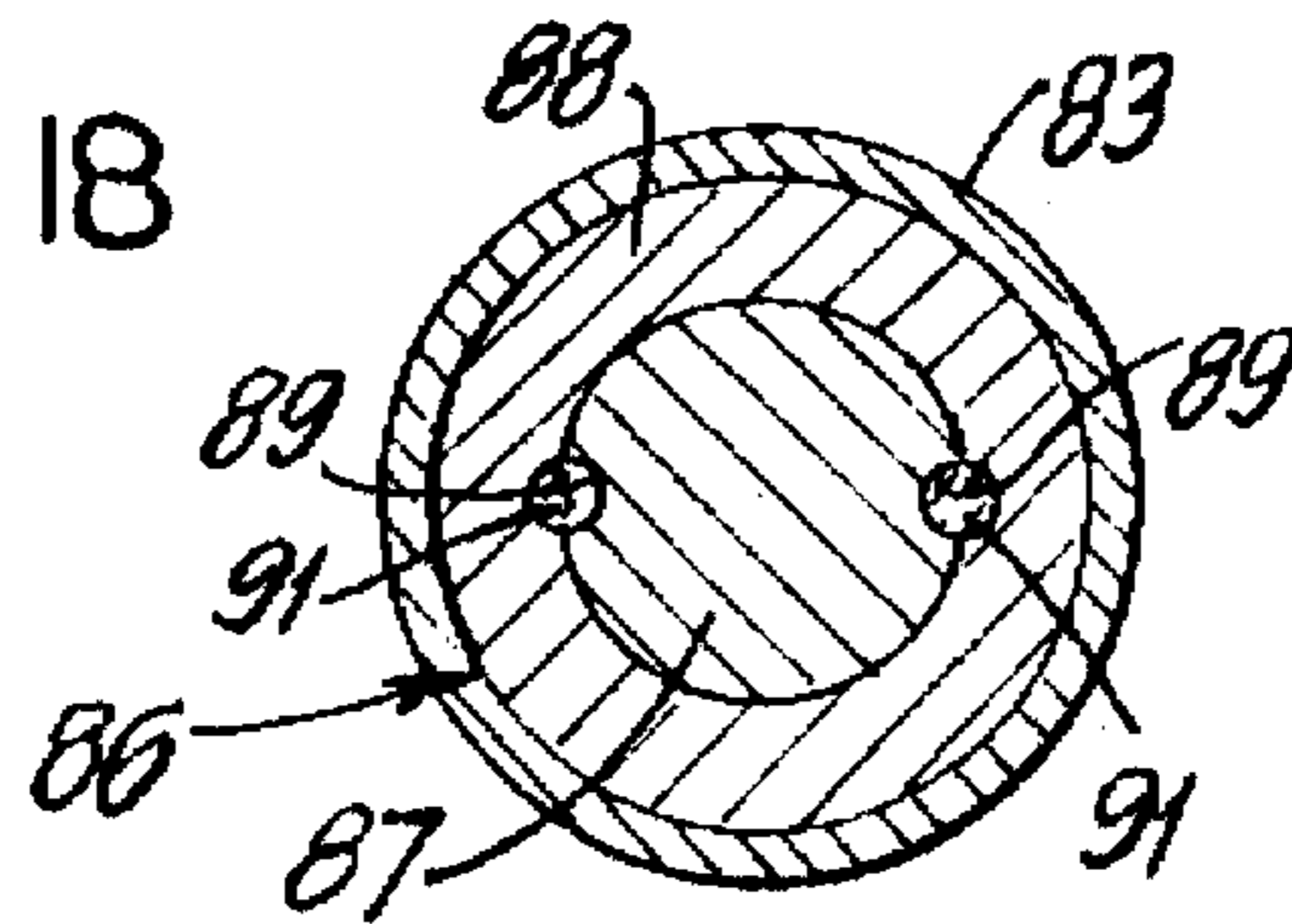

FIG. 14

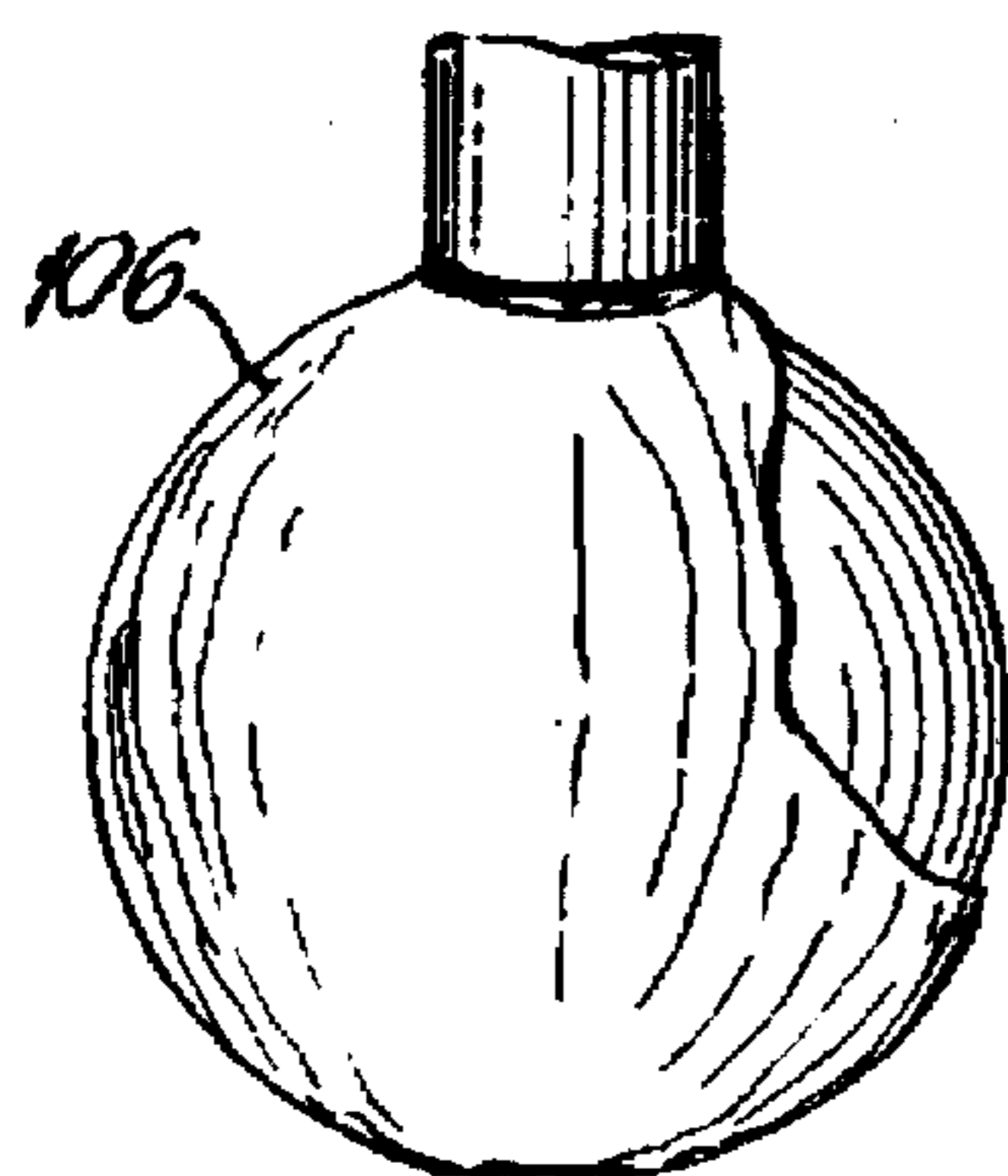

FIG. 17

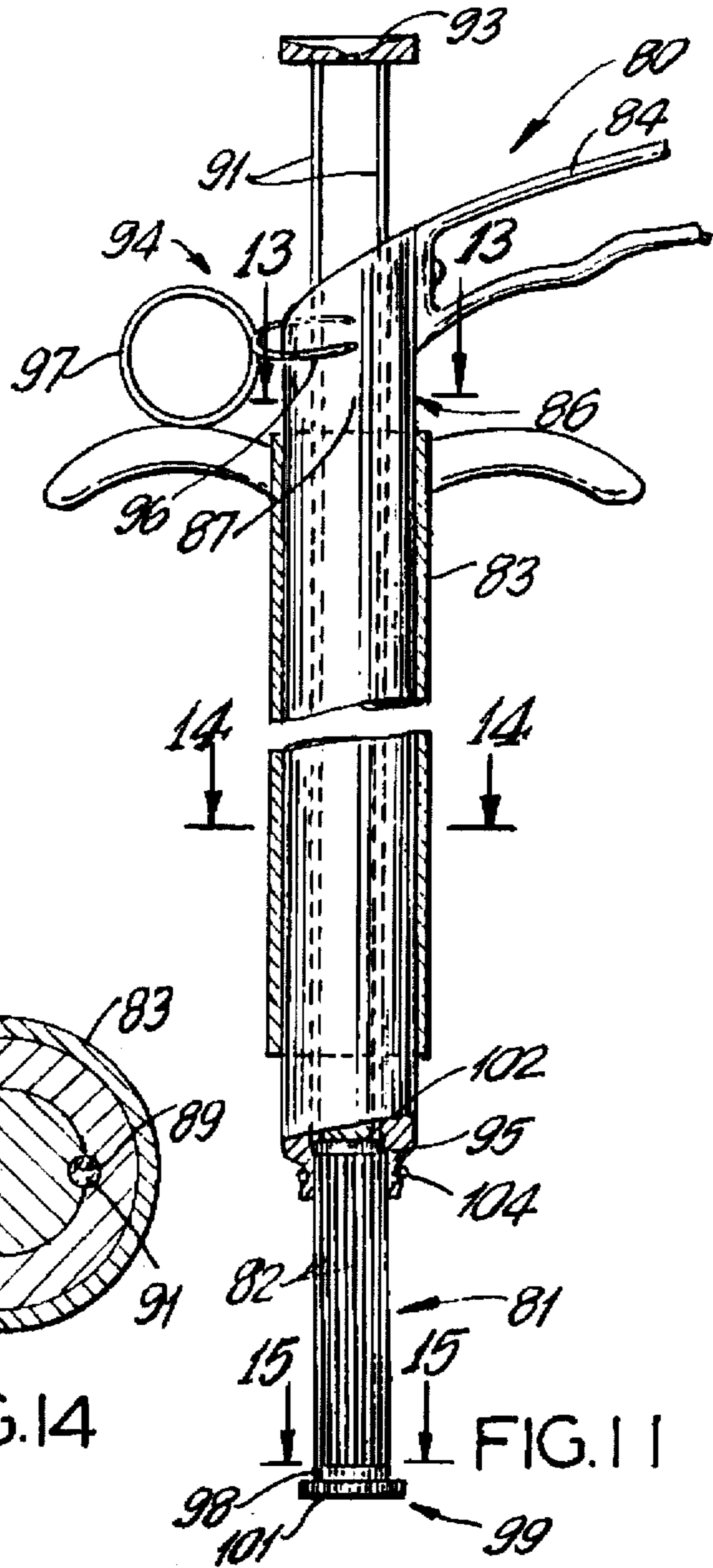

FIG. 11

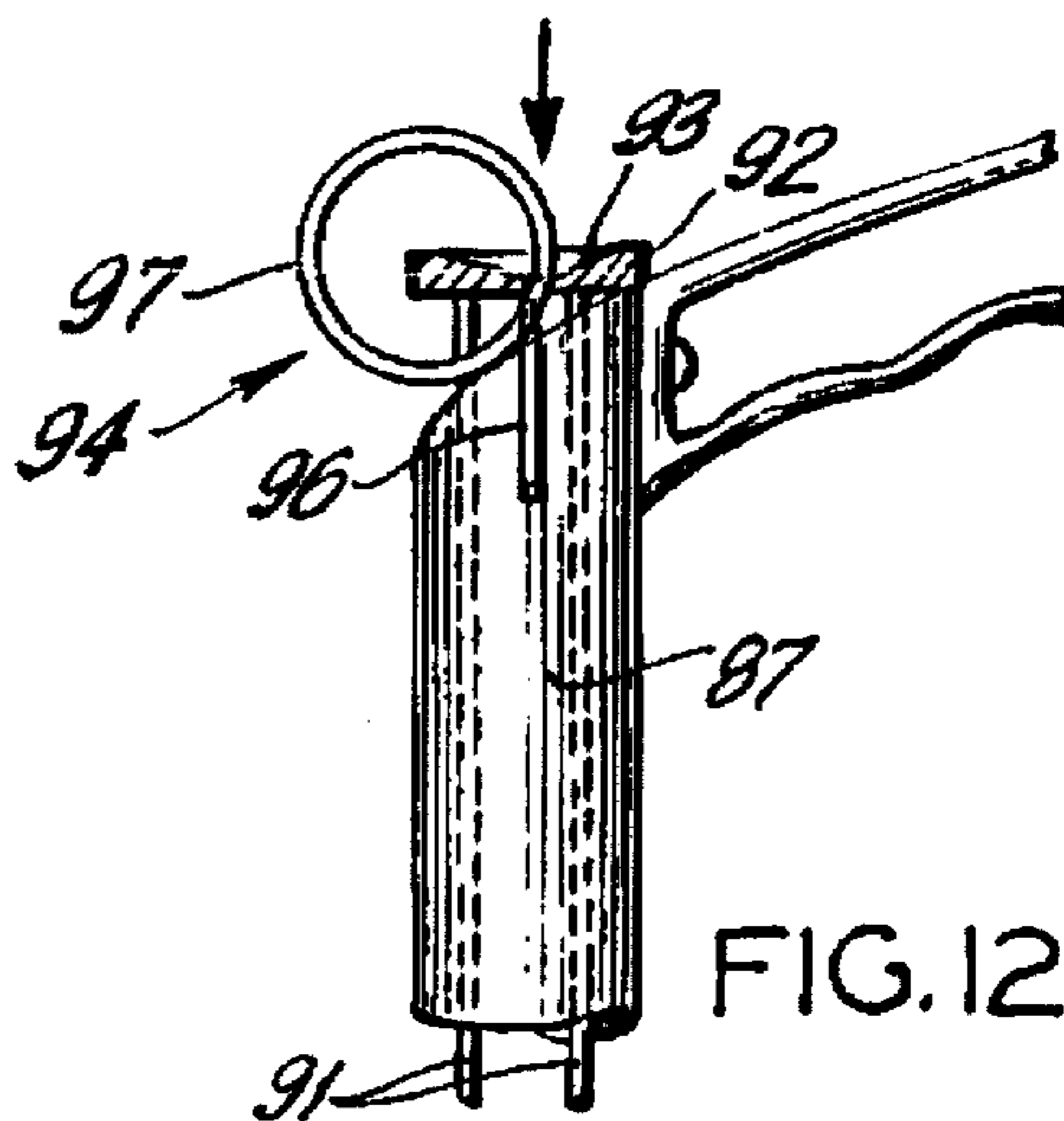

FIG. 12

## CHRISTOUDIAS ENDOSPONGESTICK PROBE

Matter enclosed in heavy brackets [ ] appears in the original patent but forms no part of this reissue specification; matter printed in italics indicates the additions made by reissue.

*This application is a reissue of application Ser. No. 07/674,470, filed on Mar. 25, 1991, now U.S. Pat. No. 5,188,630.*

### BACKGROUND OF THE INVENTION

The endospongestic probe of the present invention is an instrument designed to assist in probing, retracting or sponging intraabdominal viscera or tissue in the performance of laparoscopic surgical procedures.

With endoscopic surgery gaining widespread acceptance in the gynecological and other surgical fields, more and more procedures that were performed with conventional large, painful and temporarily disabling incisions are now utilizing the revolutionary laparoscopic modality. The need for new instruments to perform these procedures is great and the lack of such instruments is a limiting factor in the changeover to endoscopic surgical procedures.

The present invention discloses a basic assembly to facilitate endoscopic surgery. The new instrument is nowhere disclosed in the known prior art. Indeed, the prior art, because of conventional surgical techniques, had little or no use for the invention disclosed herein which is widely useful in an entirely new and revolutionary surgical technique.

### SUMMARY OF THE INVENTION

The present invention comprises a spongestic for endoscopic procedures *including retraction, and tissue and/or organ manipulation* comprising a hollow cylindrical stem with a handle at one end and a balloon receptor at the other end. The stem is surrounded by a retractable sheath having a handle projecting outwardly from its upper end. A balloon system comprising a tubular balloon surrounded by a gauze member is mounted over the receptor. Inflation means are provided to expand the balloon as desired. The hollow interior of the stem provides a passage for endoscopic instruments which function in conjunction with the balloon.

An alternate embodiment of the invention provides a gauze covered balloon which projects outwardly from the side of a half-hollow stem. The stem and retractable sheath are otherwise similar to that previously described.

A further embodiment of the invention provides spring wire means for inflating the balloon which is mounted about a receptor on the stem.

Accordingly, an object of this invention is to provide a new and improved spongestic for endoscopic procedures.

Another object of this invention is to provide a new and improved spongestic for endoscopic procedures which may be used in conjunction with other instruments.

A further object of this invention is to provide a new and improved spongestic for *retraction, and manipulation of tissues and organs* in endoscopic procedures which includes an inflatable gauze covered balloon at its lower end,

A more specific object of this invention is to provide a new and improved sponge means for endoscopic procedures which includes a stem with a balloon system at its lower end,

a handle at its upper end and a retractable sheath surrounding the stem, plus means for inflating and deflating the balloon.

### DESCRIPTION OF THE DRAWINGS

The above and other objects of the invention may be more clearly seen when viewed in conjunction with the accompanying drawings wherein:

FIG. 1 is a cross-sectional view of one preferred embodiment of the invention;

FIG. 2 is a view taken along the line 2—2 of FIG. 1;

FIG. 3 is a view of the tubular balloon utilized in connection with the invention of FIG. 1 in an uninflated condition;

FIG. 4 is a view of the balloon in an inflated condition;

FIG. 5 is a view of the tubular gauze member which is mounted over the uninflated balloon;

FIG. 6 is a view of the inflated balloon and gauze cover in place attached to the endoscopic sponge;

FIG. 7 is a view of an alternate embodiment of the invention;

FIG. 8 is a cross-sectional view taken along the line 8—8 of FIG. 7;

FIG. 9 is a view of the gauze covering for the balloon with the rubber bands at each end;

FIG. 10a is a view of the balloon in a deflated condition and FIG. 10b is a view of the balloon in an inflated condition;

FIG. 11 is a cross-sectional view of an alternate embodiment of the invention;

FIG. 12 is a partial view of the handle portion of the invention;

FIG. 13 is a cross-sectional view of the invention taken along the line 13—13 of FIG. 11;

FIG. 14 is a cross-sectional view of the invention taken along the line 14—14 of FIG. 11;

FIG. 15 is a cross-sectional view of the invention taken along the line 15—15 of FIG. 11;

FIG. 16 is a view of the spring wires in a partially expanded condition;

FIG. 17 is a view of the balloon and gauze covering in an expanded condition;

FIG. 18 is a view of the gauze balloon covering.

### DETAILED DESCRIPTION OF THE INVENTION

Referring now to the drawings, the invention comprises an endospongestic probe 10 which includes a frame 11 and a balloon system 12. The probe 10 in a preferred embodiment, see FIG. 1, includes an axial aperture 13 for insertion of endoscopic instruments to perform various procedures. The frame comprises a stem 14 consisting of an elongated metal cylinder *and tube* 24 surrounded by a retractable sheath 16 with outwardly extending handles 17 on either side of the sheath 16.

The frame 11 includes a main cylindrical stem 14, a handle 18 mounted thereto at one end, and a head 19 at the other end containing the balloon system 12. The handle 18 is of surgical steel 2 cm. wide by 3 mm. thick with smooth surfaces. Finger indentations 21 are provided on the lower surface of the handle 18 for gripping purposes. The handle 18 is affixed to the cylinder or stem 14 by conventional means forming an angle of approximately 120 degrees with

its stem 14. Manipulation of the handle 18 permits the operator to retract, sponge or probe tissues with the head 19 of the instrument 10.

The main cylindrical stem or cylinder 14 extends from an open upper end 13 to the head 19. A longitudinal groove 22 extends axially along the surface of the cylinder 14 to accommodate the inlet tube 23 of the balloon system 12. A central tube 24 extends axially within the aperture 13 and projects outwardly from the cylinder 14 including two proximal circumferential grooves 26 about its lower portion projecting from the stem 14. The lower portion of the head 19 comprises a balloon receptor surface 28. The bottom of the tube 24 includes a terminal lip 29 with a circumferential groove 31 thereabout and an exit port 29a for instruments such as a dissector, cautery, laser probe, etc.

FIG. 3 shows the tubular balloon 32 in an uninflated condition while FIG. 4 shows the balloon in an inflated condition. FIG. 5 shows the tubular gauze 33 with proximal and distal rubber bands 34 and 36, respectively, which attach the gauze 33 and balloon 32 in position. The balloon 32 is of various predetermined dimensions with a tubular receptor 28 in its center to provide stability. The balloon 32 is inflated and deflated through the inlet tube 23 with leads to a Leur lock tip 35. Air or sterile non-noxious liquid (e.g., normal saline solution or water) is injected into 35 with a syringe.

In [operation] assembly, the balloon 32 is inserted over the head (receptor) 28. The tubular gauze 33 is mounted over the balloon 32, with the rubber bands 34 and 36 securing the assembly in place. The balloon 32 is then inflated and the instrument 10 is used as a spongystick. An endoscopic instrument can be inserted through the aperture 13 and out the lower exit port 37 and used while traction or retraction of the adjacent structures is maintained by the spongystick 10.

An alternate embodiment of the invention is shown in FIG. 7. The instrument 50 allows retraction, traction or protection of the tissues while a second instrument such as a dissector, electrocautery or laser probe is being used after accommodation through the hollow compartment 51. The instrument 50 comprises the retractable sheath 52, the stem 53 and the head portion 56. The retractable sheath 52 is identical in design with the retractable sheath 11 of the endospongystick probe 10 as previously described.

The stem 53 is comprised of two components. A hollow half cylinder 55 which is affixed to a solid half cylinder 54 to form a half hollow half solid cylinder or stem of 6 mm. or more in diameter and 0.5 mm. less than the diameter of the sheath. The length of the stem 53 is from 15 to 35 cm. and is between 2 and 6 cm. longer than the retractable sheath 52. The thickness of the wall of the hollow component is 0.2–2 mm. thick.

The free end of the stem 53 is encircled by the sheath stop 57 which is a ring affixed circumferentially at the free end of the stem 53. It is 2 mm. thick and its diameter is equal to that of the stem 53. Running parallel to the main axis of the stem and on the surface of the solid component 54 is a cylindrical groove 58, 1–2.5 mm. in diameter that continues onto the head 56 to the opening 59 of the head. This groove 58 will accommodate the inlet tube 61 of the balloon [catheter].

The head 56 includes the hollow 55 and solid 54 components affixed together into a cylindrical structure as in the stem 53. The head 56 varies in length from 3–8 cm. and has on the solid component a symmetrical spherical or elliptical depression 59 starting 1 cm. from the end of the instrument 50 and 5 mm. from the proximal rubber acceptor groove 64.

This depression 59 reaches a depth of 1 or more mm. from the main axis of the instrument 50 and accommodates the balloon.

Circumferentially and at a distance of 0.5–1 cm. from the edge of the depression 59 and perpendicular to the main axis lie the proximal groove 64 and distal groove 65 which will accommodate the rubber bands 66 and 68 of the gauze member 67 respectively.

The balloon system is identical to that of the instrument 10 described earlier with the only difference that the balloon 70 expands towards one side of the catheter when insufflated. The gauze 67 is also similar to that previously described and is open at both ends and there is an elastic band 66, 68 at each end.

With the balloon in place, in the receptor recession 59 of the head 56 and the tubular gauze 67 in place about the balloon 70 and the retractable sheath 52 drawn over the head 56, the instrument 50 is inserted through the appropriate trocar port into the abdominal cavity. The sheath 52 is retracted and the balloon insufflated with air or sterile or non-pyrogenic non-toxic fluid (e.g., normal saline or water). The desired operating instrument is inserted via the hollow component into peritoneal cavity through a valve cap which is affixed at the exposed open end to avoid loss of the pneumoperitoneum.

Any instrument such as a tissue dissector, electrocautery or laser probe can be inserted in this fashion into the peritoneal cavity. The adjacent tissues or organs (e.g., liver in cholecystectomy or bowel or abdominal wall in bowel resection to the intended surgical target (gallbladder adhesions, etc.) are retracted with the balloon portion of the instrument 50 the appropriate instrument advanced to the intended target and dissection, resection, cauterization or separation of the target is accomplished by the operator.

The advantages of the balloon retraction are a) tissues are stretched and can be dissected or resected or separated easier; b) normal tissues adjacent to the intended target are retracted away from it and thus protected from the laser probe or electrocautery; and c) by retracting back the operating instrument, the balloon can be used for sponging or probing the different tissues or organs allowing better visualization and exposure of the pathology and/or intended target.

The probe 80 is shown in FIG. 11 as an alternate embodiment of the invention and is similar to the probe 10 of FIG. 1. The fundamental difference is that the expansion of the head 81 is accomplished by pressure on a system of spring ribbons or wires 82 that are compressed between a fixed and a movable point.

This instrument 80 is comprised of retractable sheath 83 identical to the retractable sheath 16 of probe 10, and a solid frame comprising the handle 84, the stem 86 and the head 81.

The handle 84 is identical with the handle of the probe 10 and the stem 86 of probe 80 is similar in dimensions to the stem 14 of probe 10 with the following differences in its features. The stem 86 has no groove along its surface. The stem 86 has two components—a central cylindrical, solid structure 87 of 3–5 mm. in diameter and a peripheral cylindrical tubular structure 88 of 2–9 mm. in diameter and 2–7 mm. in wall thickness. The central structure 87 fits into the peripheral structure 88 and both are slidably mounted together to form the stem 86. Diametrically opposite and on the inner surface of the peripheral tubular surface 88 and the convex surface of the central solid cylinder 87 are two semicircular 0.5 mm. to 2 mm. wide grooves 89 that run

5

parallel to the long axis of the stem **86**. When assembled, these two components of the stem **86** are fixed in position with each groove **89** of each instrument facing perfectly the groove of the other instrument so that a cylindrical path is created which will accommodate the control wires **91**. The wall of the tubular peripheral structure **88** at the distal 1.5 cm. towards the head is thinner by 1 mm. than the rest of the proximal peripheral structure the difference being carved out of the inside surface of the structure so that a circular space of 1 mm. is created to accommodate the pressure ring **95** and spring ribbons or wires **82**.

Within the cylindrical path between the peripheral **88** and central **87** structures are located the control wires **91** which are between 0.5 mm. and 2 mm. in diameter. These control wires **91** project 2 cm. to 4 cm. beyond the stem **86** at the handle end of the stem **86** and converge to a 2 mm. ring **92** which encircles the (central) main axis of the stem **86**. Onto this ring **92** concave handle **93** is affixed at its center where the two limbs lead into a 5 mm. depression 1.5 mm. deep and 5 mm. wide, in the center of which there is a 2 mm. ring **92** for affixing this handle **84** onto the ring **92** of the control wires **91**. This depression will accommodate the swing spring **94** and keep the head expansion in place after advancement of the control wires **91** towards the head **81**.

On the handle side of the stem **86** at diametrically opposite sides and at right angles to the plane between the control wires **91** is affixed a swing loop spring **96** at 2 points 1.5 cm. from the points of exit of the control wires **91** from the stem **86**. This loop swing spring **96** is 2 cm. long and through its loop passes a 2 cm. control ring **97** which with the appropriate traction arms the ring **97** and positions it over the depression (5a) of handle **84** of the activated control wires **91**, thus securing the activated control wires **91** in place and maintaining the expansion of the head **81**.

The head **81** is comprised of a central solid cylinder **98** which is a continuation of the upper solid central cylinder portion of the stem **86** and is of a diameter of 1-3 mm. less than the diameter of the stem central cylinder **98**. This cylinder **87** is 2-6 cm. long and at its tip is attached at the center of the concave surface of a thick cup **99**, thus forming a stop to the distal ring **101**.

Over this central cylinder **98** and affixed on two rings **101**, **102** are between one and 20 spring ribbons and/or spring wires **82** which when compressed between the proximal **102** and distal rings **101**, by advancement of the control wires **91** mushroom out into a spherical structure that will expand the diameter of the head **81**. The rubber band receptor groove **104** is identical to that of probe **10**. The tubular gauze **106** is identical to the tubular gauze described with regard to probe **10** except that endoscopic instruments can be inserted through gauze member **36**.

In use the tubular gauze **106** is placed over the wires **82** in the head **81** with the rubber band resting in the respective groove **104**. The retractable sheath **83** is advanced over the head **81** and the instrument inserted via the trocar port into the abdominal cavity. The sheath **83** is retracted towards the handle **84** and the control wires **91** advanced and secured in place with the loop swing spring. The probe **80** is then ready to be used.

While the invention has been explained by a detailed description of certain specific embodiments, it is understood that various modifications and substitutions can be made in any of them within the scope of the appended claims which are intended also to include equivalents of such embodiments.

6

What is claimed is:

1. A spongystick for endoscopic procedures used in conjunction with endoscopic instruments comprising:

a main rigid stem comprising an elongated cylinder having an axial aperture extending therethrough, an outer cylinder surface having a longitudinal groove extending along said outer surface, an upper cylinder portion having a handle projecting outwardly from said upper portion and a lower cylinder portion;

a retractable cylindrical sheath slidably mounted about the stem cylinder having an upper portion and at least one handle extending outwardly from the upper portion thereof;

a central tube for insertion of endoscopic instruments therethrough mounted within the stem aperture and extending outwardly therefrom, said tube including an upper circumferential groove adjacent the stem and a lower tube portion having a lower circumferential groove; and

a balloon and a tubular gauze member surrounding the balloon at the lower portion of the central tube and having upper and lower elastic bands which mount in the respective circumferential tube grooves securing said balloon and gauze member in position, said balloon having an elongated inflation tube extending upwardly along the longitudinal groove to the upper portion of the stem cylinder, and wherein the balloon and gauze member include axial apertures through which the tube extends.

2. A spongystick for endoscopic procedures in accordance with claim 1 wherein:

the retractable sheath includes two handles, each extending outwardly on opposite sides of the sheath at its upper portion and the balloon inflation tube includes and upper portion having a Leur lock tip mounted thereto.

3. A spongystick for endoscopic procedures used in conjunction with endoscopic instruments comprising:

a rigid stem comprising an elongated hollow cylinder having upper and lower portions and internal and external cylinder walls for insertion of endoscopic instruments therethrough; said hollow cylinder further comprising a solid portion and a hollow portion extending along the length thereof;

a retractable rigid sheath slidably mounted about the stem and having at least one handle projecting outwardly therefrom;

said lower portion having a concave recess within the solid portion of the external cylinder wall;

balloon means mounted about the lower portion of the stem within said recess; and

means for inflating said balloon means to protrude outwardly from said recess.

4. A spongystick in accordance with claim 3 and further comprising: a groove extending longitudinally along the external cylinder wall extending from said recess to the upper portion of the stem, and said means for inflating said balloon means including an elongated inflation tube connected to said balloon means and positioned within the longitudinal groove of the stem and extending to the upper portion of the stem, wherein said hollow portion of the stem may be used for endoscopic procedures.

5. A spongystick in accordance with claim 3 wherein:

said stem further includes a pair of circumferentially spaced grooves about said lower portion of said cylin-

der, said balloon means comprising a balloon, a flexible gauze cover surrounding the balloon and means for securing ends of said balloon means within said circumferential grooves.

6. A spongystick for endoscopic procedures and used in conjunction with endoscopic instruments comprising:

a main hollow rigid stem comprising a cylinder having upper and lower portions and internal and external cylinder walls, said stem including a handle extending outwardly from said upper portion at an angle thereto and atleast two longitudinal grooves extending longitudinally along the internal cylinder wall thereof from the upper portion of the cylinder to the lower portion thereof; and further including a solid elongated tube having upper and lower ends mounted within the cylinder and having an external wall and at least two longitudinal grooves extending along the external tube wall opposite the longitudinal cylinder grooves in the internal cylinder wall and forming passageways;

a lower member mounted adjacent the lower end of the tube having resilient means extending downwardly, and a fixed bottom platform, said resilient means connected between said lower member and said platform, and control wires mounted to the lower member and extending upwardly through the groove passageways and having an upper end extending outwardly therefrom; and further comprising balloon means mounted about the resilient means between the lower member and the platform, said balloon means being expanded by activation of said control wires.

7. A spongystick in accordance with claim 6 further including:

a ring mounted to the upper end of the control wires and means on the upper end of the stem cylinder to engage the ring and lock the control wires in position with the balloon means expanded.

8. The method of endoscopically sponging a patient comprising the steps of:

providing an elongated sponging instrument for insertion into a patient, said instrument having a handle at one end an interior stem extending outward from the handle and an external sheath mounted about the stem;

inserting a balloon over the stem of the instrument projecting from the sheath;

mounting a tubular gauze member over the balloon prior to inflation;

sliding the sheath over the gauze member, balloon and interior stem before insertion of the instrument into a body cavity;

inserting the sponging instrument into a body cavity in a patient;

retracting the sheath and inflating the balloon to expand the gauze for contact with the patient within the body cavity, and

manipulating the instrument with the handle and sheath to perform a sponging operation.

9. The method of retracting, and manipulating tissues and/or organs within a body cavity in an endoscopic procedure comprising the steps of:

providing an instrument comprising an elongated hollow stem surrounded by a retractable sheath for insertion into a body cavity and having a balloon mounted over one end of the stem and a gauze member mounted over the balloon in an uninflated condition;

sliding the end of the stem with the balloon and surrounding gauze member into the retractable sheath before insertion into a body cavity;

inserting the instrument into a body cavity with the balloon uninflated;

disengaging the sheath and said one end of the stem inflating the balloon to expand the gauze member within the body cavity; and,

manipulating the instrument to perform a sponging operation; said sponging operation comprising retraction and manipulation of the tissues or organs within the body cavity with the gauze member by movement of the stem.

10. The method of retracting, and manipulating tissues and/or organs in accordance with claim 9 further including the step of:

inserting instruments through the hollow stem to perform surgical operations.

11. The method of retracting, and manipulating tissues and/or organs in accordance with claim 9 further including the step of:

deflating the balloon and removing the instrument from the body cavity.

12. A spongystick for manipulating, and retracting tissues and/or organs in endoscopic procedures within a body cavity used in conjunction with endoscopic instruments comprising:

a rigid stem comprising an elongated cylinder having an axial aperture extending therethrough;

a retractable cylindrical sheath slidably mounted about the cylindrical stem for insertion into a body cavity;

a central tube having a lower portion and an upper portion for insertion of endoscopic instruments therethrough mounted within the stem aperture and extendable outwardly therefrom;

a balloon and a gauze member surrounding the balloon mounted at the lower portion of the central tube; and, means for inflating the balloon to provide means to, manipulate, and retract tissues within the body cavity.

13. A spongystick for manipulating, and retracting tissues and/or organs in endoscopic procedures within a body cavity used in conjunction with endoscopic instruments in accordance with claim 12 wherein:

the stem includes an upper handle portion for directing the movement of the balloon and gauze member within the body cavity.

14. A spongystick for endoscopic procedures used in conjunction with endoscopic instruments comprising:

a main rigid stem comprising an elongated cylinder having an axial aperture extending therethrough, an outer cylinder surface having a longitudinal groove extending along said outer surface;

a retractable cylindrical sheath slidably mounted about the stem cylinder;

a central tube for insertion of endoscopic instruments therethrough mounted within the stem aperture and extending outwardly therefrom; and

a balloon and a tubular gauze member surrounding the balloon at the lower portion of the central tube and having means securing said balloon and gauze member in position, said balloon having an elongated inflation tube extending upwardly along the longitudinal groove to the upper portion of the stem cylinder, and wherein the balloon and gauze member include axial apertures with the central tube extending therethrough.