



US00RE35098E

United States Patent [19]

[11] E

Patent Number: Re. 35,098

Saperstein

[45] **Reissued Date of Patent: Nov. 28, 1995**

[54] **METHOD OF MAKING A HEAT EXCHANGER**

1096610 6/1955 France .
1097396 7/1955 France .

[75] Inventor: **Zalman P. Saperstein**, Gurnee, Ill.

(List continued on next page.)

[73] Assignee: **Modine Manufacturing Co.**, Racine, Wis.

OTHER PUBLICATIONS

Brazing Manual, pp. 90-91 (3rd Ed. 1976) by the American Welding Society Committee on Brazing and Soldering.

[21] Appl. No.: **569,228**

(List continued on next page.)

[22] Filed: **Aug. 17, 1990**

Related U.S. Patent Documents

Reissue of:

[64] Patent No.: **4,377,024**
Issued: **Mar. 22, 1983**
Appl. No.: **250,111**
Filed: **Apr. 2, 1981**

U.S. Applications:

[63] Continuation of Ser. No. 426,462, Oct. 20, 1989, abandoned, which is a continuation of Ser. No. 220,914, Jul. 19, 1988, abandoned, which is a continuation of Ser. No. 20,163, Feb. 26, 1987, abandoned, which is a continuation-in-part of Ser. No. 105,626, Dec. 20, 1979, abandoned.

[51] **Int. Cl.⁶** **B23P 15/26; B23K 31/02; F28F 9/02**

[52] **U.S. Cl.** **29/890.043; 29/890.054; 29/890.046; 165/175; 165/906; 228/175; 228/183**

[58] **Field of Search** **29/890.043, 890.046, 29/890.054; 228/175, 183, 214; 165/173, 175, 178, 906**

[56] **References Cited**

U.S. PATENT DOCUMENTS

2,270,864 1/1942 Blais .
2,886,881 5/1959 Huet 285/381
2,914,346 11/1959 Ryder .
2,961,222 11/1960 Butt 228/183

(List continued on next page.)

FOREIGN PATENT DOCUMENTS

1039911 10/1953 France .

Primary Examiner—P. W. Echols

Attorney, Agent, or Firm—Wood, Phillips, VanSanten, Clark & Mortimer

[57] **ABSTRACT**

A method of making a heat exchanger of the type used in vehicle radiators and having a core of spaced welded, as contrasted to lock-seam, tubes and interconnecting fins connected to spaced liquid tanks. The method, which permits machine-operated mass production of these exchangers, comprises stacking solder-coated core tubes in vertically spaced sets of a plurality of essentially horizontal tubes with serpentine fins located between each vertical pair of tube sets, arranging a top and a bottom rigid support plate against each of the topmost and bottommost tube sets, applying compression to the resulting stack through the support plates, banding the stack into an easily handled rigid assembly, applying a header plate to each essentially vertical side of the assembly with the tube ends extending through corresponding holes in the header plates, gang welding the projecting ends of the tubes to the exterior of the respective header plates by means of a movable multihead automatic welder, dipping this core assembly into a liquid soldering flux dip, blowing heated air at a temperature above the melting point of the solder over the outer surfaces of the core assembly to bond the fins to the tubes, applying a solder sealant coating over the adjacent junction areas of tubes and header plates that are opposite to the welds, the welds thereby being on the liquid side and the solder on the air side and finally removing the support plates and bands from the core and attaching the enclosing tanks to the header plates in fluid tight relation.

22 Claims, 5 Drawing Sheets

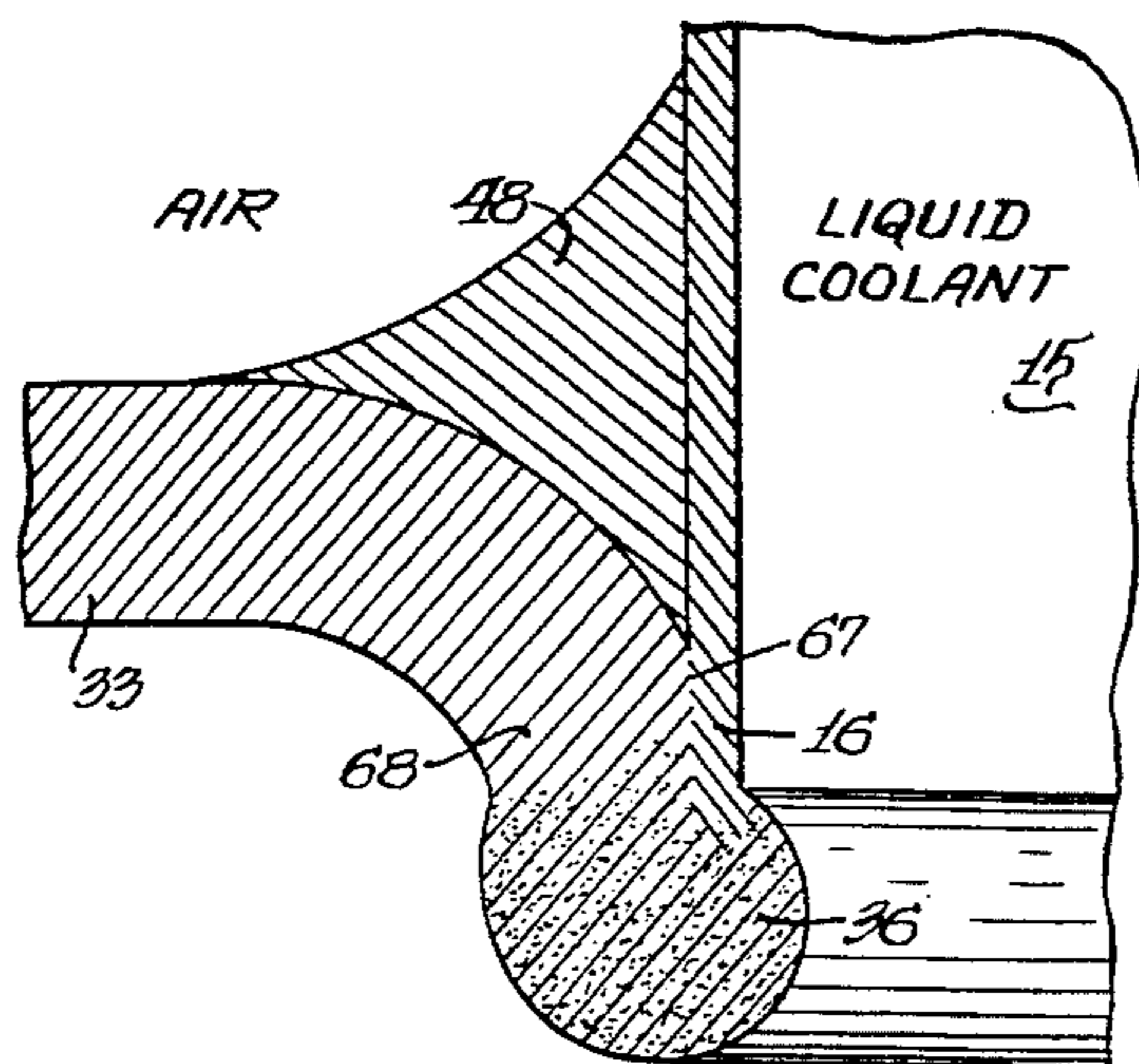

U.S. PATENT DOCUMENTS

2,996,600	8/1961	Gardner, Jr. et al. .	
3,027,142	3/1962	Albers et al.	165/DIG. 9
3,078,551	2/1963	Patriarca et al.	29/157.4
3,229,760	1/1966	Hurter et al.	165/134 R
3,245,465	4/1966	Young	165/173 X
3,265,125	8/1966	Rosenblatt .	
3,266,567	8/1966	Oddy et al.	165/151
3,266,861	1/1978	Broodman	165/173 X
3,349,464	10/1967	Becker, Jr. et al. .	
3,407,874	10/1968	Gier, Jr. .	
3,472,316	10/1969	Couch, Jr.	165/175 X
3,496,629	2/1970	Martucci et al.	29/157.4 X
3,512,238	5/1970	Canon et al. .	
3,589,440	6/1971	Friedrich .	
3,633,660	1/1972	Young .	
3,689,941	9/1972	Chartet .	
3,693,710	9/1972	Drosnin	29/890.046
3,702,632	11/1972	Grimshaw .	
3,710,473	1/1973	McElwain et al. .	
3,710,858	1/1973	Young .	
3,726,466	4/1973	Vedder et al.	29/890.043
3,750,747	8/1973	Hingorany .	
3,763,536	10/1973	Young .	
3,769,675	11/1973	Chartet .	
3,787,945	1/1974	Pasek et al. .	
3,823,464	7/1974	Chartet .	
3,833,986	9/1974	DeCicca .	
3,855,682	12/1974	Chartet	29/890.046
3,857,151	12/1974	Young et al. .	
3,941,293	3/1976	Chartet .	
3,981,354	9/1976	Haberski .	
4,026,456	5/1977	Lema .	
4,081,650	3/1978	Barger et al. .	
4,090,657	5/1978	Anderson .	
4,128,235	12/1978	Gersbacher	228/183
4,159,034	6/1979	Bellovary et al. .	
4,183,402	1/1980	Cotter .	
4,221,263	9/1980	Meyer	165/173
4,223,924	9/1980	Schwarz .	
4,233,719	11/1980	Rhodes .	
4,274,483	6/1981	Cottone et al.	228/198
4,305,459	12/1981	Nonnenmann et al.	165/173
4,327,802	5/1982	Beldam .	
4,373,369	2/1983	Schey .	
4,391,027	7/1983	Fleury	29/890.046
4,399,196	8/1983	Schey .	
4,400,965	8/1983	Schey .	

FOREIGN PATENT DOCUMENTS

1544006	10/1968	France .
2045742	5/1971	France .
132541	6/1902	German Dem. Rep. .
2115434	3/1971	Germany .
2810274	11/1978	Germany .
53-41821	10/1978	Japan .
6515663	3/1968	Switzerland .
422936	4/1974	U.S.S.R. .
890896	3/1962	United Kingdom .
1332777	10/1973	United Kingdom .
1445598	8/1976	United Kingdom .
2017761	10/1979	United Kingdom .

OTHER PUBLICATIONS

Soldering Manual, p. 25 (2nd Ed. 1978) by the American Welding Committee on Brazing and Soldering.
 Sheet Metal Theory and Practice, pp. 60-64 (1944) by John C. Butler.
 Repair of Aluminum Heat Exchangers by R. W. Gunkel, SAE Technical Paper (1979, pp. 1-8).

Auto Radiator Repair & The Cooling System by Harry Horowitz, (1972) pp. 4-7, 105-106, 155, 205-206.
 Plasma Arc Welding Copper Alloy 260 by IIT Research Institute (1973) pp. 1-12.
 Heat-Exchanger Fabrication, The Welding Journal by P. Patriarca, G. M. Slaughter and W. D. Manly (1957) pp. 1172-1178.
 Welding and Brazing of High Temperature Radiators and Heat Exchangers, The Welding Journal by G. M. Slaughter, E. A. Franco-Ferreira and P. Patriarca (1968) pp. 15-22.
 The Fluxless Brazing of Aluminum Radiators by J. C. Warner and W. C. Weltman, SAE Technical Report (1978) pp. 1-11.
 "The Welding Encyclopedia," T. B. Jefferson, Ed., 1951.
 "Ford Mechanically Assembled Aluminum Radiator"; Vel-ing, Marsh, Dickirson, Glaser 1983.
 "Elemente des Apparatebaves," Dr.-Ing. Hubert Titze 1967.
 "Soft Soldering," Roy Andrews, 1978.
 "Soft-Soldering Handbook," International Tin Research Institute, C. J. Thwaites Jan. 1982.
 Soldering Manual, American Welding Society, 1954.
 "Weld Sealant Spray Technique Ends Leaks From Air Con-ditioners, Converters", Loctite Corp. Dec. 16, 1976.
 Welding Metallurgy; G. E. Linnert, 1963.
 "Care of the Water Cooling System," R. A. Leavell, Auto-mobile Institute Jan. 20, 1917.
 Soldering Manual, American Welding Society, Inc. Apr. 1. 1977.
 Welding and Brazing Techniques for Nuclear Reactor Com-ponents, Gerald M. Slaughter, 1964.
 "Cost Effective Brazing and Soldering of Sheet Metal," Engineering, Aug. 1975.
 The Repair of Aluminum Heat Exchangers, R. A. Morley/T. L. Wilkinson Oct. 1978.
 The Fluxless Brazing of Aluminum Radiators, J. C. Warner/W. C. Weltman, Alcoa Lab, Aluminum Co. of America 1979.
 Application Development Report #13, Loctite Corporation, 1978.
 Technical Report, Copper Development Association Inc.
 Automotive Journal, "Aluminum Radiators", W. C. Welt-man Mar.-Apr. 1970.
 Metals Handbook, "Welding and Brazing", American Soci-ety for Metals Aug. 1971.
 "New Light-Weight Design Copper and Brass Radiator Performance Compared with Production Radiators", Lustwerk/Batson Lytron, Inc.
 Weld & Porosity Sealing Loctite AA/Weld Sealant & Loctite 290 Loctite Corporation, 1979.
 "New Ways to Stop Leakage with Locite Products" Locite Corp., 1969.
 "Field Repair of Aluminum Coolers," Modine Mfg. Co. No Publ'n Date.
 "Metal Flow and Fillet Formation in Brazing Aluminum Welding" Journal No. 2, Feb. 1946.
 Produkcja chlodnic samochodowych w aspekcie technic-zno-ekonomicznej optymalizacji procesu lutowania miek-kiego,—Stanislaw Brys No Publ'n Date.
 Use of Aluminum Heat Exchangers in Motor Vehicles, G. Kreuzer, Dec. 1980.
 "Today's View of the Aluminum Automotive Radiator," Kaechele/Herr, Society of Automotive Engineers Sep. 26-30 1977.
 Einsatz von Aluminum—Wärmeaustauschern in Kraftfahr-zeugen G. Kreuzer, Stuttgart No Publ'n Date.
 "Today's View of the Aluminum Automotive Radiator"

- Kaechele/Herr, Sep. 26, 1977.
(Identified as #10) Dipl.—Ing. Manfred Koch and Walter Mobius No Publ'n Date.
- Material Used in Radiator Construction, No Publ'n Date.
Automotive Industries, Loctite Leakproofs Vehicles, Mar. 1, 1976.
- "Anaerobic Sealants Offer Leakproof Vehicles," Automotive Industries, Mar. 1, 1976.
- Fernandez, Bruce, *Modern Machine Shop*, "Seal It, Bond It, Lock It, Retain It—With Adhesives". No Publ'n Date.
- Dowd, J. D., Supplement to the Welding Journal, Mar. 1954, "Soldering of Aluminum".
- Series of Abstracts—#4 No Publ'n Date.
- "The Roles of Copper and Brass", Dec. 1969.
- Tomorrow's Auto Radiators, "New Copper Alloy Meets New Needs", W. E. Johnston No Date.
- "Field Repair of Aluminum Coolers", H. D. Huggins No Date.
- Automotive Aluminum/Plastic Radiator Service Manual, Harrison Radiator Division, General Motors Corp. No Publ'n Date.
- Merrick Automated MIG Welding Units Assemble Heat Exchanger Cores, Merrick Engineering, Inc. No Publ'n Date.
- "The Roles of Copper and Brass" Dec. 1969.
- "New Copper Alloy Meets New Needs," W. E. Johnston, Tomorrow's Auto Radiators No Publ'n Date.
- "Field Repair of Aluminum Coolers" Modine Mfg. Co, H. D. Huggins No Publ'n Date.
- Series of Abstracts—#3.
- SAE Technical Paper Series, "Design of Radiators for Low Flow Cooling Systems", Richard F. Crook and Joseph S. Ju—Gec. 1985.
- SAE Technical Paper Series, "Development of a Welded Copper—Brass Automotive Radiator," J. H. Anders et al. 1983.

FIG. 1.

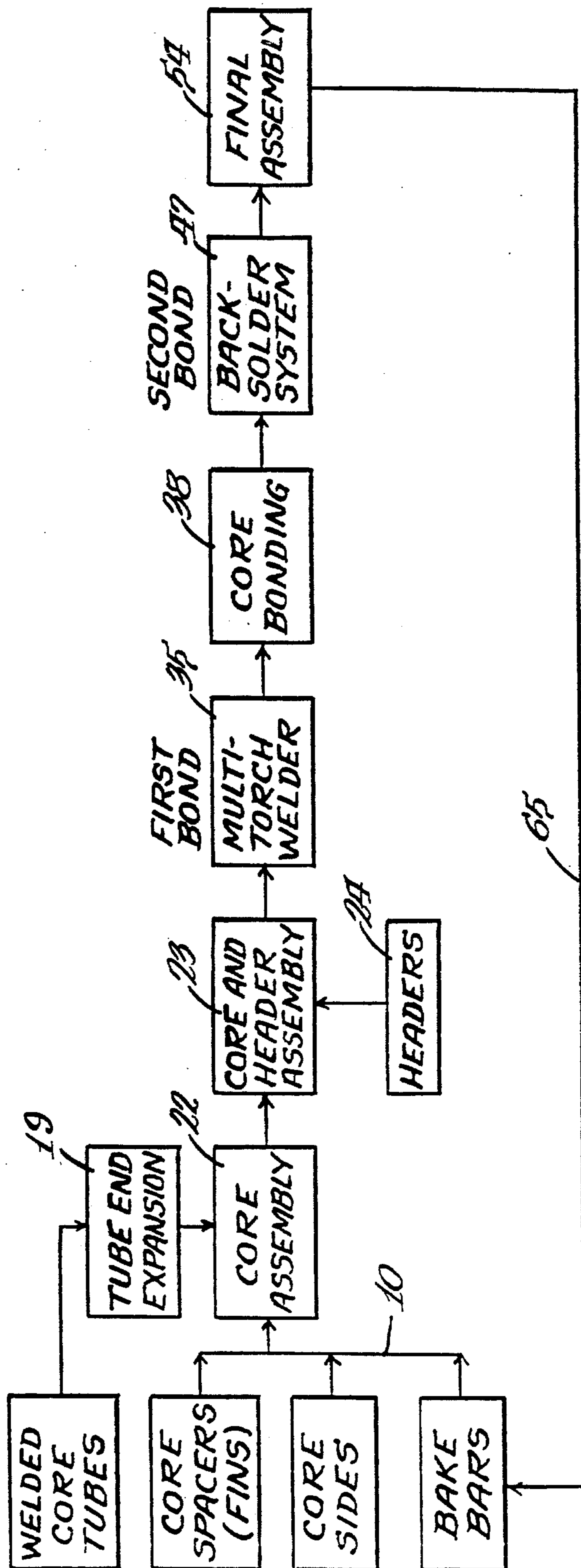

Fig. 2.
CORE
ASSEMBLY

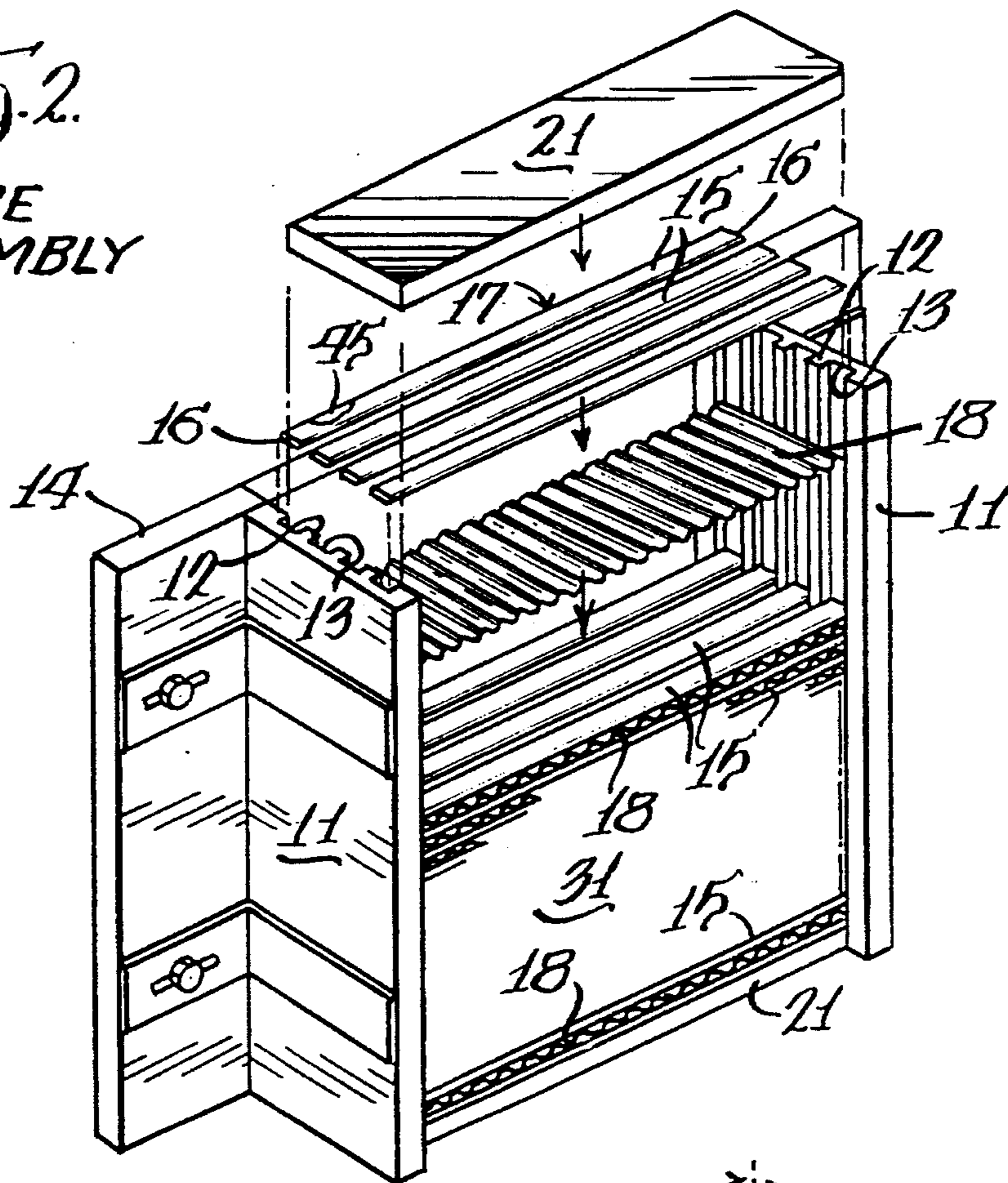

Fig. 3.
CORE AND
HEADER
ASSEMBLY

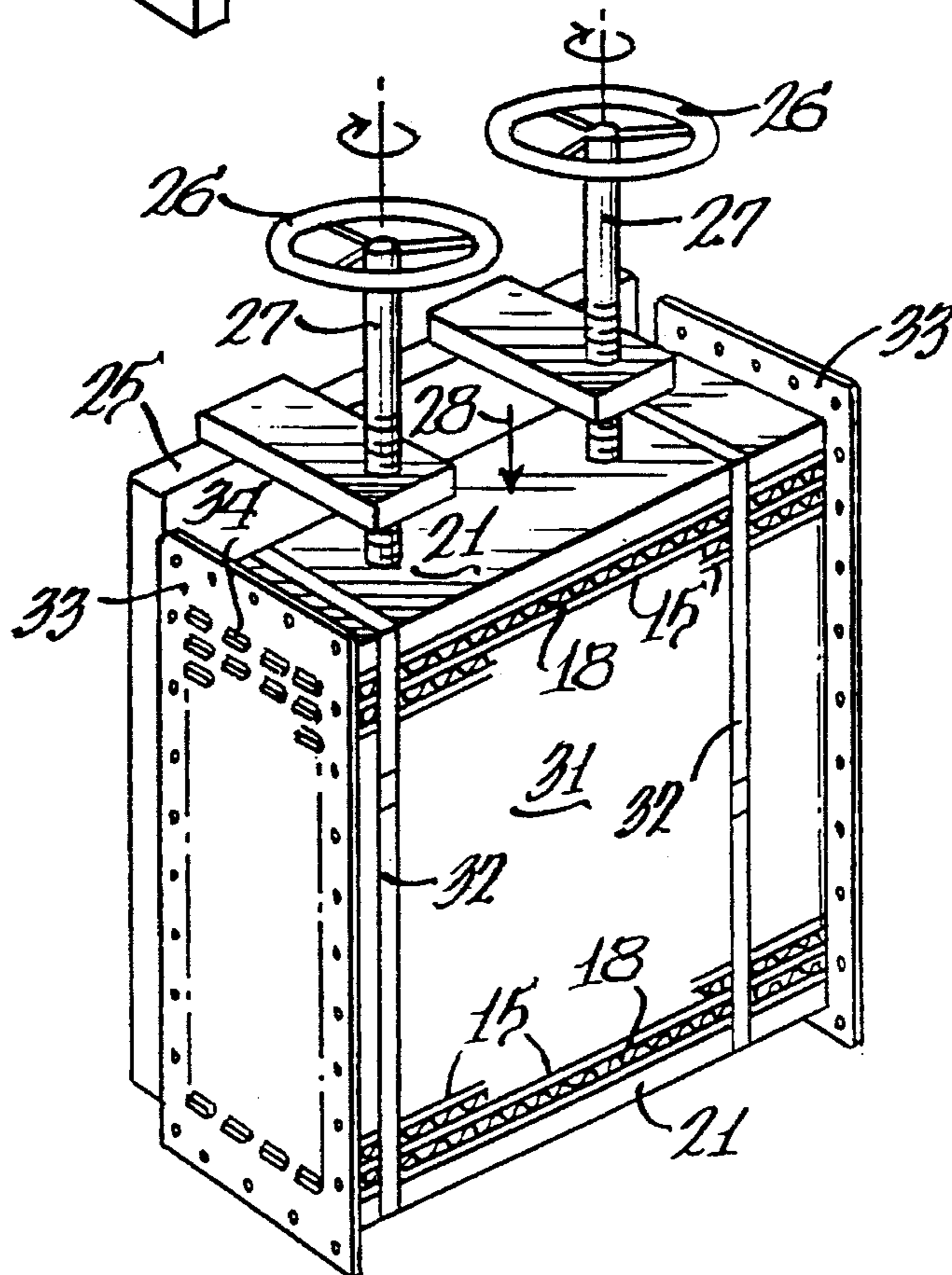

Fig. 4.
MULTI-TORCH
WELDING

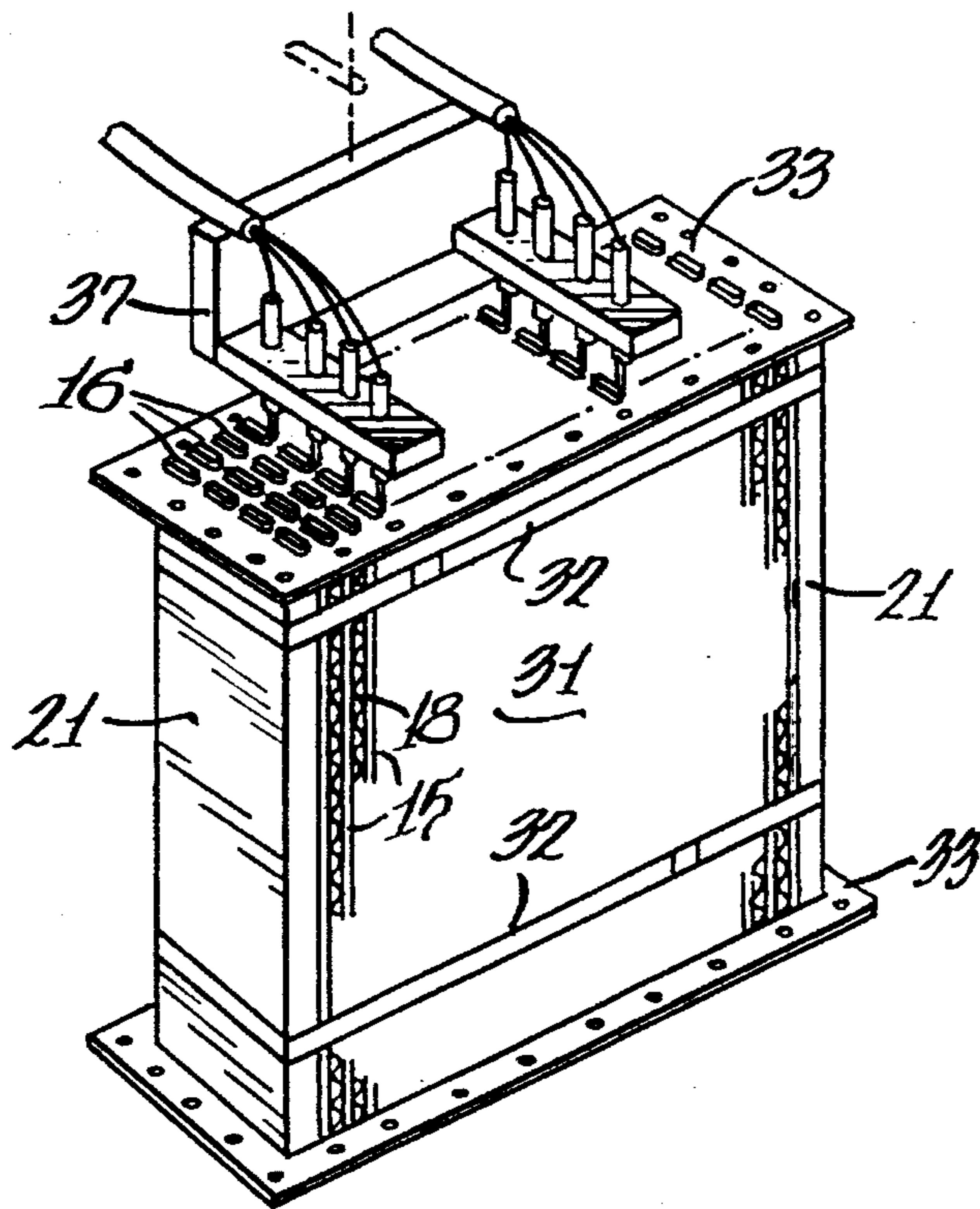
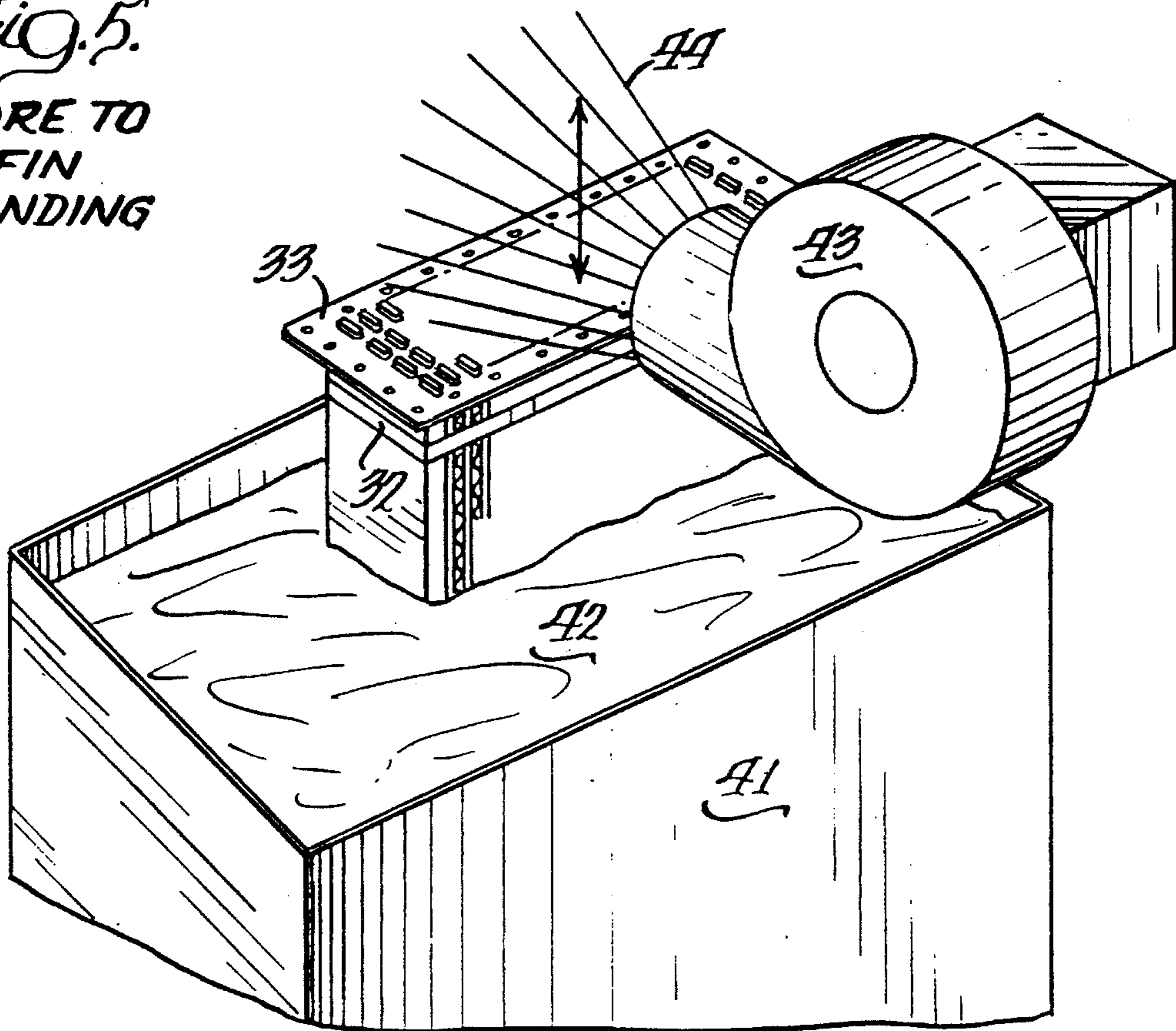

Fig. 5.
CORE TO
FIN
BONDING



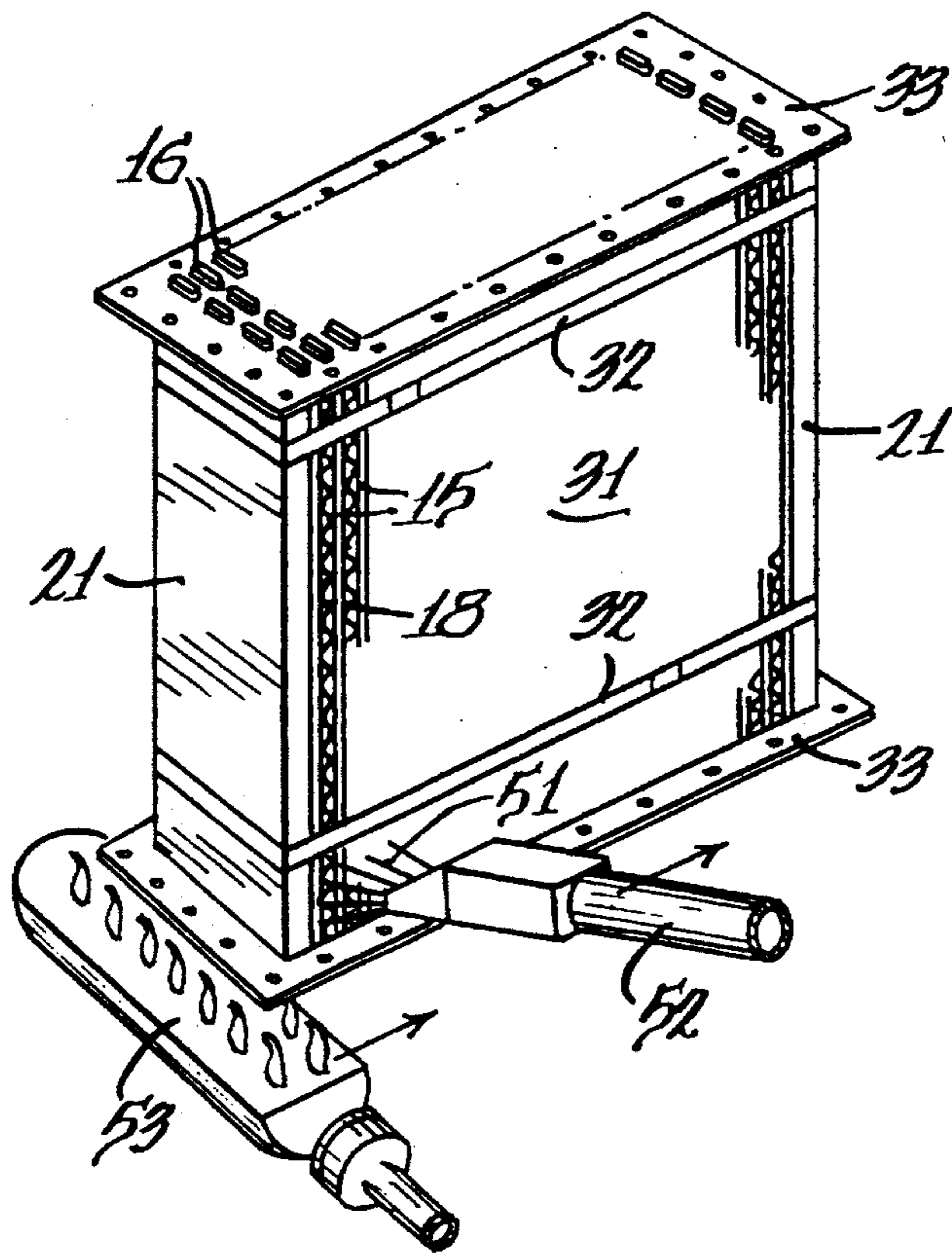
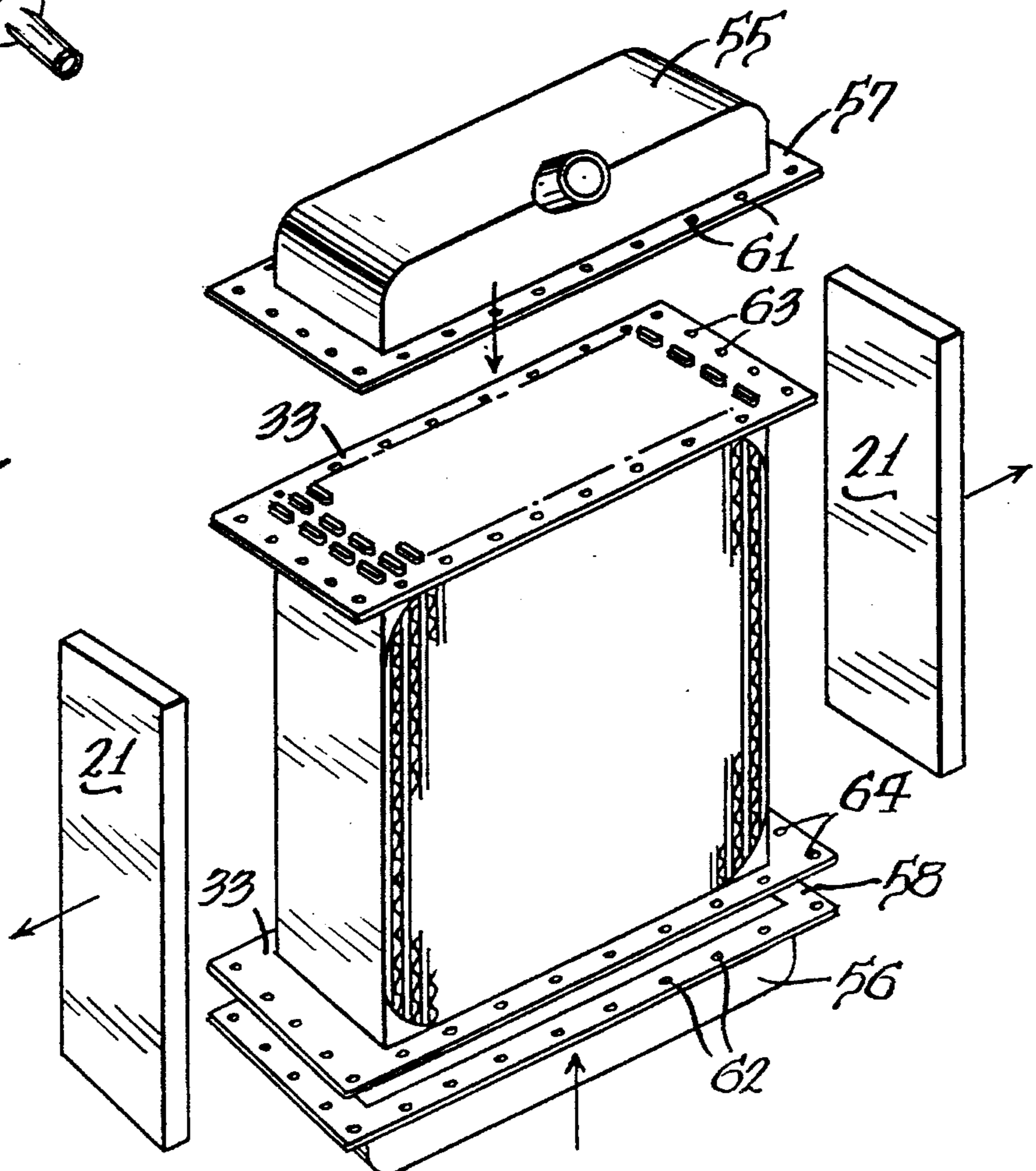
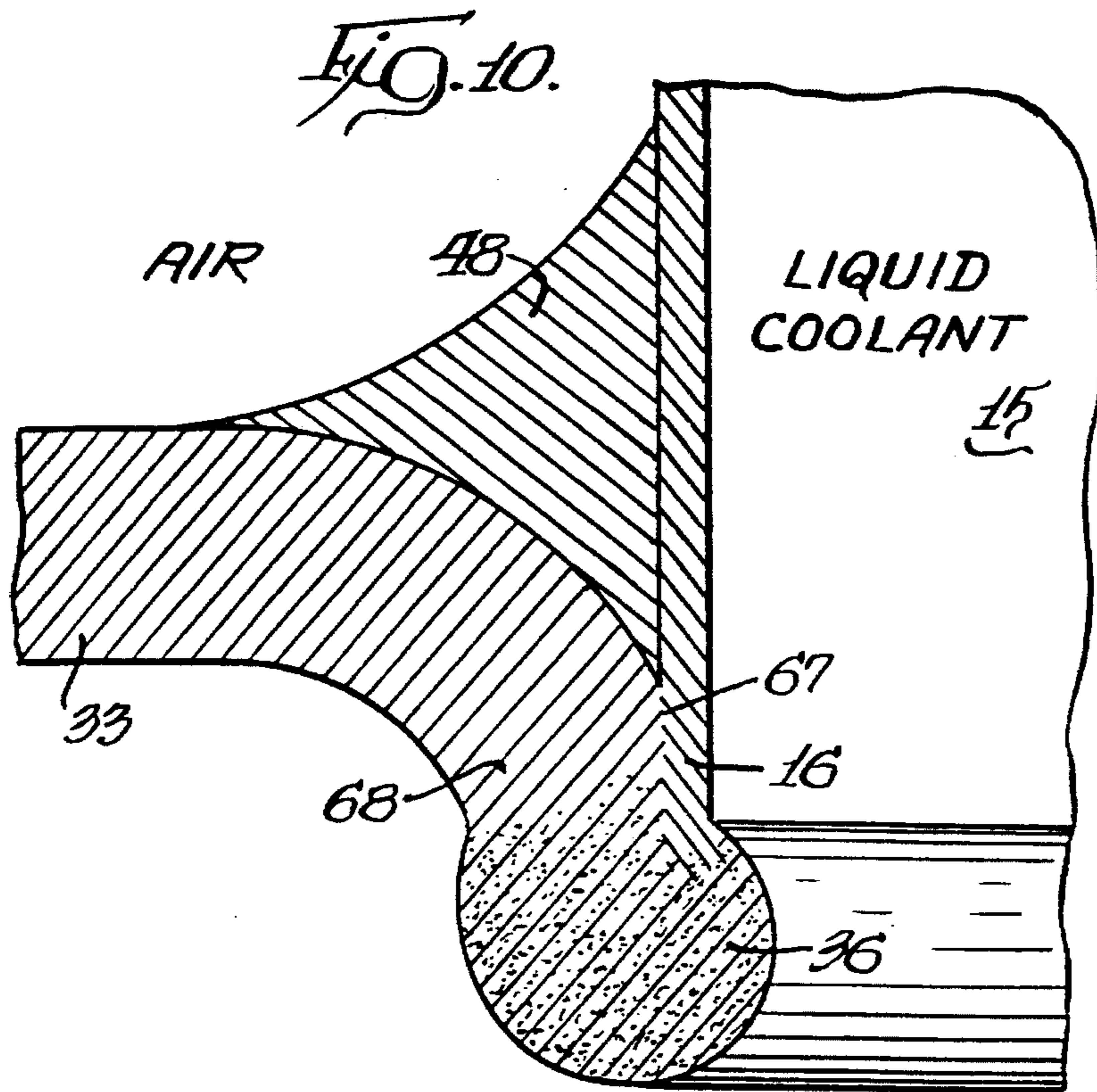
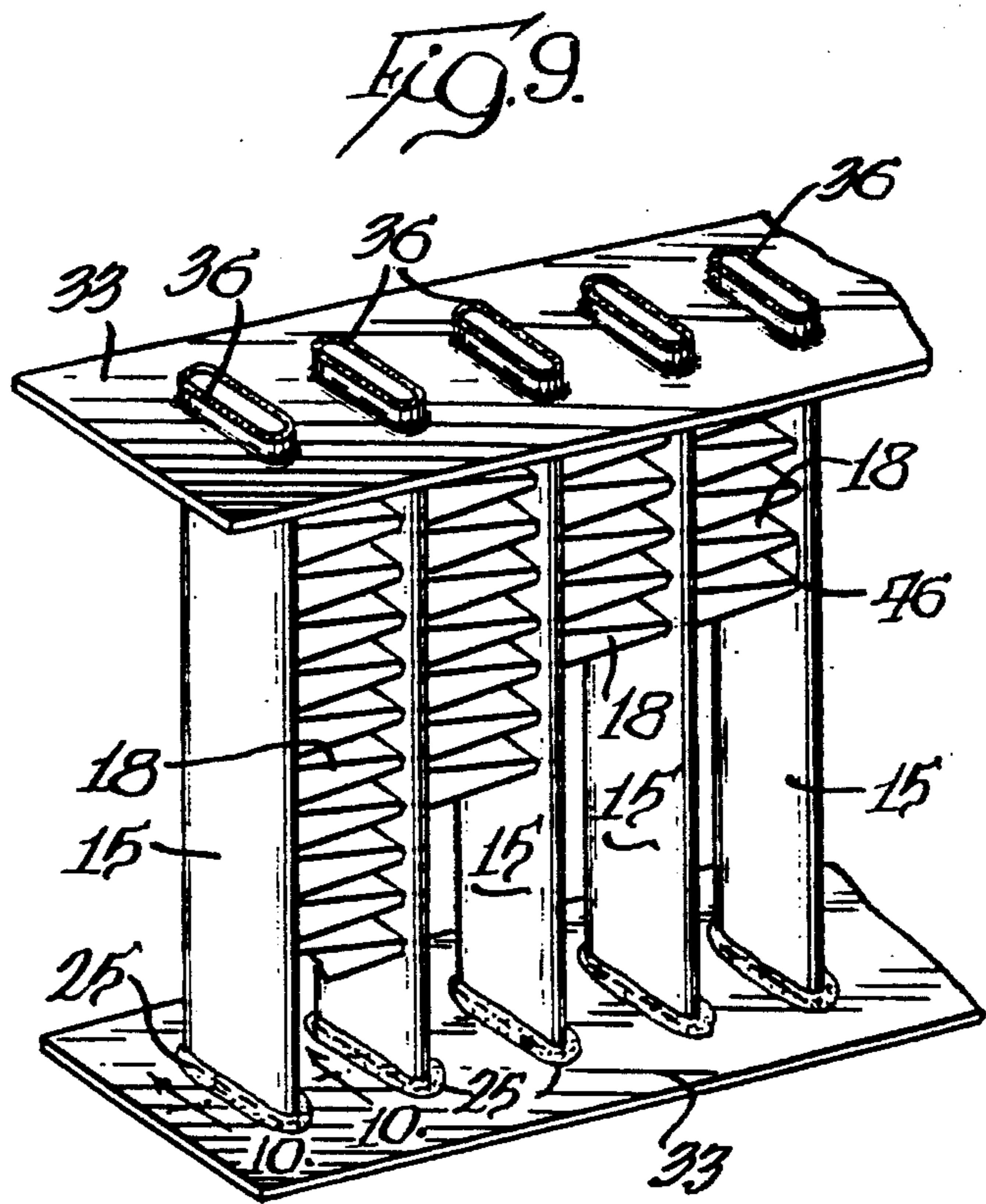
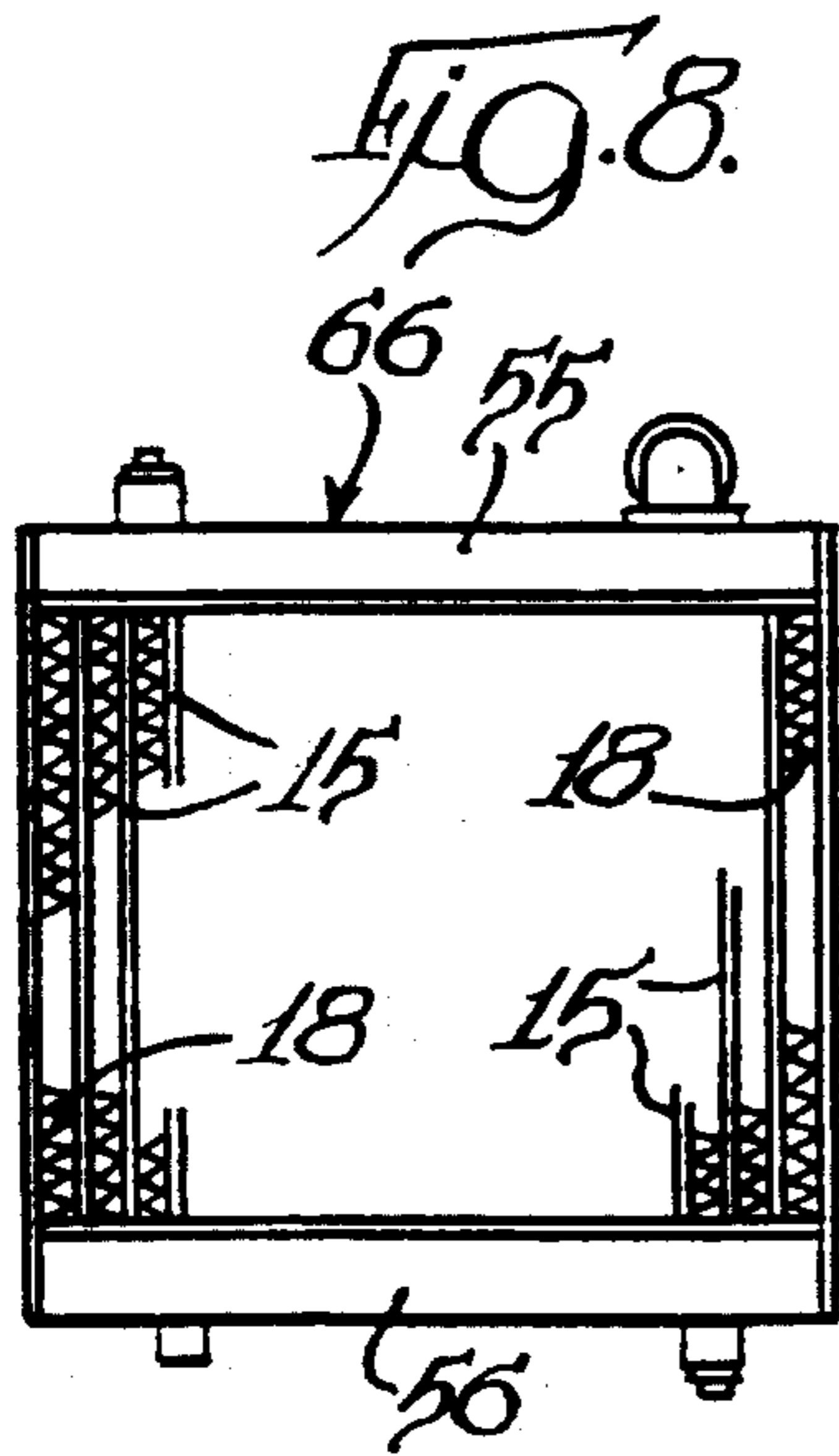

FIG. 6.
BACK-SOLDER
SYSTEM

FIG. 7.
FINAL
ASSEMBLY





METHOD OF MAKING A HEAT EXCHANGER

Matter enclosed in heavy brackets [] appears in the original patent but forms no part of this reissue specification; matter printed in italics indicates the additions made by reissue.

This application is a continuation of application Ser. No. 426,462, filed Oct. 20, 1989, now abandoned which is a continuation of Ser. No. 220,914, filed on Jul. 19, 1988 now abandoned which is a continuation of Ser. No. 20,163 filed on Feb. 26, 1987 now abandoned and a Re-Issue of Ser. No. 771,448 filed on Mar. 12, 1985, now abandoned, which is a Re-Issue of Ser. No. 250,111, filed Apr. 2, 1981 now U.S. Pat. No. 4,377,024 which is a continuation-in-part of Ser. No. 105,626 filed on Dec. 20, 1979 now abandoned.

BACKGROUND OF THE INVENTION

Heat exchangers of the liquid-air type used in automotive vehicle cooling systems, air conditioning systems and the like, involve considerable labor to produce. Where automatic machinery is used to produce the exchanger, especially where weldment construction is employed at the joints uniting the parts, there is frequently a large percentage of rejects because of pinholes, fissures and other leakage openings in one or more of the weldment joints. Even one such leakage opening results in rejecting the exchanger. Such an opening is ordinarily difficult to locate and laborious and expensive to correct.

The method of this invention permits the step-by-step mass production of heat exchangers and avoids substantially entirely the leakage problem by providing, a sealant coating of solder over the air side of the welds which are themselves on the liquid side. In addition, any leakage is from the liquid interior of the heat exchanger to the outer air side so that its detection and correction are easily accomplished.

The invention will be described in one embodiment thereof as illustrated in the accompanying drawings.

BRIEF DESCRIPTION OF THE DRAWINGS

FIG. 1 is a flow chart illustrating the successive steps in the mass production method of this invention;

FIG. 2 is a schematic exploded perspective view of an initial step in making the core assembly;

FIG. 3 is a schematic perspective view illustrating the next step in the method;

FIG. 4 is a similar schematic perspective view illustrating the gang welding of the projecting ends of the tubes to a header plate;

FIG. 5 is a schematic fragmentary perspective view illustrating one embodiment of uniting the tubes of the core to the intermediate fins which serve as spacers;

FIG. 6 is a schematic fragmentary perspective view illustrating the applying of the sealant solder which functions as a second bond;

FIG. 7 is an exploded schematic perspective view illustrating the final assembly of the heat exchanger;

FIG. 8 is a schematic front elevationai view, partially broken away, of a completed heat exchanger produced according to the method of the invention;

FIG. 9 is a schematic fragmentary perspective view of a partially complete heat exchanger manufactured by the

method of this invention;

FIG. 10 is an enlarged fragmentary schematic sectional view taken substantially along line 10—10 of FIG. 9.

BRIEF DESCRIPTION OF THE ILLUSTRATED EMBODIMENT

FIG. 1 illustrates the flow chart for mass producing the heat exchangers illustrated at FIGS. 8, 9 and 10 according to the methods of this invention in which the important steps are illustrated in the successive FIGS. 2-7, inclusive.

As illustrated by the flow chart of FIG. 1, the welded core tubes, core spacers or fins, core sides or rigid support plates, grooved side assembly plates and bake bars or rigid support plates are arranged at the beginning 10 of the parts flow as illustrated in FIG. 1. In an initial step 19, the ends 16 of the welded tubes are expanded so as to fit snugly in holes 67 in the header plates 33 and to prevent inward distortion during welding of the tube ends to the header plates.

A core assembly is then produced as illustrated in FIG. 2 in which a core assembly fixture has sides in the form of parallel plates with confronting surfaces 12 that are provided with spaced vertical grooves 13. These side plates 11 are held in an adjustable bracket 14 and are spaced apart a distance equivalent to the spacing of the header plates in the heat exchanger.

In making the core assembly, coplanar sets of solder-coated tubes 15 are arranged between the side plates 11 with the ends 16 of tubes held for movement in the grooves 13. In the illustrated embodiment, there are four of the tubes 15 to a set and these tubes are the customary flat or oval cross-section structure.

Arranged between each set of tubes 17 is a spacer here shown as a serpentine fin 18. As can be seen from FIG. 2, the core assembly comprises a series of alternate sets 17 of tubes and intervening fins 18.

The top and bottom of the core assembly are each provided with a "bake bar" 21 which operate as top and bottom-rigid support plates. These bake bars are movable relative to and extend between the side surfaces 12 of the plates 11. The method step of FIG. 2 is illustrated in the flow chart of FIG. 1 at 22.

In the next step, as illustrated at 23 and 24 and shown in detail in FIG. 3, the assembly of FIG. 2 is held in a bracket 25 that is provided with pressure screws 27. These screws engage the tube support plate 21 to apply pressure thereto as illustrated by the arrow 28. This pressure compresses the assembly of plates 21 and sets 17 of tubes with intervening fins 18 into tight contact. While so held, the stack 31 is banded into an easily handled rigid assembly by applying a plurality, here shown as two, of spaced, taut metal tie bands 32 around the stack including the support plates 21 and encircling the stack as shown in FIG. 3.

As a part of the production of the assembly shown in FIG. 3 and illustrated at 24 in FIG. 1, the header plates 33 are forced over the projecting ends 16 of the solder-coated welded tubes 15 by causing these ends to project through similarly shaped openings 34 in these plates.

The resulting assembly which now includes the header plates 33 is moved to the next station 35 of the assembly method where the first bond or weld joint is made uniting each tube end to each header plate. At this station 35 where the first bond weld 36 is applied on what will become the liquid side of the [head] heat exchanger, there is provided a gang welding multitorch welder 37. As is illustrated in FIG.

4, this welder welds eight tube ends 16 simultaneously to the corresponding header plate 33 and as is customary with this type of equipment, the welding is automatically controlled.

In the next station of the process, as illustrated at 38 in FIG. 1 and at FIG. 5, the core assembly from FIG. 4 with the tube ends welded to the header plates 33 is dipped into a tank 41 of liquid solder flux 42 of a customary type and then withdrawn from this solder flux bath 42 past the exhaust of a hot air blower 43 whose hot air exhaust 44 is at a temperature above the melting point of the solder, illustrated at 45 in FIG. 2, coating on the tubes 15. This core bonding at station 38, as illustrated at FIG. 5, unites the fins 18 at their crests 46 to the flat sides of the tubes 15.

At the next station 47, shown schematically in FIG. 1, the second bond or back soldering of the welds 36 is applied. Here, as is illustrated in FIG. 6, the air side solder sealant 48 is applied. In the illustrated embodiment, this is accomplished by blowing a flowing mixture 51 of powdered solder and flux over the adjacent junction areas of the header plates 33 and tube ends 16 on the air side. This can easily be accomplished by a commercially available blower 52. As can be seen from FIG. 10, the solder sealant or second bond 48 is located on the air side of the exchanger while the welds 36 are on the liquid side. The solder sealant 48 is provided as shown by heating the exterior of each header plate 33 by means of a traversing burner 53 from which heat is conducted through the header plate 33 to the area of the solder 48 where the solder is melted to provide the second bond or solder sealant 48.

At the next station 54 (FIG. 1) of the flow chart of FIG. 1, the final assembly steps occur. Here the upper tank 55 and lower tank 56 are attached. Each of these tanks has a flange 57 and 58 provided with bolt holes 61 and 62 for cooperating with similar bolt holes 63 and 64 at the outer edges of the top and bottom header plates 33. At the same time, the tie bands 32 are removed and the bake bars or support plates 21 are removed and returned to the beginning station as illustrated by the elongated arrow 65 in FIG. 1.

The method of this invention provides a second bond which is the air side solder coating 48 that is useful both in strengthening the unit and also providing a sealant for any small openings that may develop. Welds 36 being located on the liquid side of the heat exchanger leak toward the air side as shown at FIG. 10 if any leaks should occur.

Heat exchangers of this type, particularly thin wall tube weldment type heat exchangers, are difficult to make in commercially desirable high rates of production through the use of production machines because of an undesirably high amount of leakage. The method of this invention permits high speed production of weldment heat exchangers even with thin wall tubes, with practically no leakage openings because the solder sealant is in position to fill any such leakages should they occur. The solder also provides a secondary bond for added strength. Among the metals that can be welded and which are therefore useful in making heat exchangers by the method of this invention are steel, oxygen-free or deoxidized copper, brass and aluminum.

As is shown in detail in FIG. 10, the tube-receiving hole 67 in each header plate 33 is defined by a flange 68 which projects outwardly in that it is turned outwardly from the plane of the plate 33. Each flange 68 and the corresponding tube end held therein have substantially coplanar surfaces before the welding that provides the welds 36. This combination of welds 36 and solder seals 48 results in a heat exchanger 66 that is very strong not only because of the welds but also because of the dual bond construction that

comprises the combination of the welds 36 and solder seals 48.

The important points to be kept in mind are that solder joints are well-known to be weak, normally averaging about 10–40 lb/in of solder fillet. Welded brass, on the other hand, is very strong, for example about 30,000–33,000 psi tensile strength. However, [there] *the* the welds are prone to defects caused by zinc fuming, thermal distortion and irregularities, and the solder precoatings on the tubes.

In view of the above properties, a 1.2-inch long solder fillet is capable of sustaining a tensile load of about 12–48 lb. A weldment tube-to-header joint [is] *in* the same tube (0.5 × 0.096 radiator tube with a 0.006-inch thick tube wall) will sustain a tensile load of about 216–238 lb. or about 4.5 to 20 times more load-carrying ability than the soldered joint. The dual bond of this invention, therefore, is characterized by the weld containing small defects. The solder sealant of the dual bonded joint, however, having excellent capillary flow properties, fills any defects in the welds to provide a leak-tight structure. Thus, the welds provide about 75–95% of the maximum sustainable load while the solder of the dual bond fills any leakage openings and also contributes to the strength of the dual bond combined joint.

Thus, the solder joint is weak and a weld joint is strong, but one without the other is deficient because the soldered joint is not strong enough while the weld joint may leak. A leaky welded joint structure cannot be used without the solder sealant. The two together, therefore, provide high joint strength and a substantial absence of leaks. Actual tests have shown that the combination as described and claimed herein has a structural life at least 5–10 times longer than the conventional soldered heat exchanger where everything else is the same.

I claim:

1. In making a weldment heat exchanger having an air side core of spaced tubes and interconnecting fins extending between liquid tanks, the method comprising:

- (a) stacking solder-coated welded core tubes in a plurality of spaced sets of a plurality of spaced tubes each with serpentine fins arranged between each adjacent pair of tube sets;
- (b) arranging end rigid support plates against each of the end tube sets to provide a stack;
- (c) applying compression to the resulting stack through said support plates, the tubes having substantially coplanar ends projecting beyond the sides of the stack;
- (d) banding said stack into an easily handled rigid assembly by applying a plurality of spaced, taut tie bands around the support plates and encircling said stack;
- (e) applying a header plate to each side of the assembly *having tube ends* with said tube ends extending through corresponding holes in the header plates;
- (f) gang welding [said] *the* projecting ends to the exterior of said header plates by means of a movable, multi-head, automatic welder;
- (g) dipping the resulting core assembly into a liquid soldering flux;
- (h) blowing heated air at a temperature above the melting point of said solder over the outer surfaces of said core assembly to bond the fins and tubes together;
- (i) blowing a flowing mixture of solder and flux over the adjacent junction areas of the tubes and header plates that are opposite to the location of [said] *the* welds, the welds thereby being on the liquid side of the heat exchanger and the solder mixture on the air side;

5

(j) heating said adjacent areas of the tubes and header plates to melt said solder mixture and thereby coat the said adjacent areas of the tubes and header plates with solder to seal the air side of the welds at said adjacent areas against any leakage opening that may occur in the welds;

(k) removing said end support plates and spaced bands from said core; and

(l) attaching a tube enclosing liquid tank to each of said header plates in fluid tight relation.

2. The method of claim 1 wherein each [said] of the tube receiving [hole] holes in the header plates is defined by an outwardly projecting flange relative to said core that overlies the projecting ends of the tubes.

3. The method of claim 2 wherein each flange and corresponding tube end have substantially coplanar end surfaces with the welds being essentially located at the coplanar ends.

4. The method of claim 1 wherein said core tubes are arranged in spaced sets with the serpentine fins inserted between each adjacent pair of tube sets, said sets being generally parallel to each other and generally perpendicular to the header plates.

5. The method of claim 1 wherein said compression that is applied to the said stack is sufficient to retain the contacting surfaces of support plates, tubes and fins in intimate contact with each other throughout steps (a)-(j) of said making of the heat exchanger, said intimate contact being maintained by said taut tie bands.

6. The method of claim 1 wherein said assembly is held in position with the one ends of tubes projecting upwardly during the welding of the one set of tube ends of the header flanges and the assembly is then rotated to arrange the other ends of the tubes upwardly for the welding of these ends to their header plate.

[7. The method of claim 1 wherein said solder mixture is blown along the air side of each header.]

8. The method of claim 1 wherein said stacking of the tubes, serpentine fin spacers and end support plates is in an assembly fixture having confronting surfaces intersected by vertically spaced grooves in which the ends of the sets of tubes are held and between whose confronting surfaces the fin spacers are located.

9. The method of claim 1 wherein steps (a)-(l), inclusive, are performed sequentially in the sequence listed.

10. In making a weldment heat exchanger having an air side core of spaced tubes and interconnecting fins extending between liquid tanks, the method comprising:

(a) stacking a plurality of solder-coated tubes in a plurality of spaced sets with fins arranged between each adjacent pair of tube sets;

(b) arranging rigid end supports against the stack;

(c) applying compression to the resulting stack through said supports, the tubes having substantially coplanar ends projecting beyond the sides of the stack;

(d) securing said stack in an easily handled rigid assembly;

(e) applying a header plate to each side of the assembly having tube ends with said tube ends extending through corresponding holes in the header plates;

(f) gang welding the projecting ends to the exterior of said header plates by relatively moving said stack and a multi-head, automatic welder;

(g) applying a soldering flux to the resulting core assembly;

(h) applying heat at a temperature above the melting point

6

of said solder over the outer surfaces of said core assembly to bond the fins and tubes together;

(i) applying solder over the adjacent junction areas of the tubes and header plates that are opposite to the location of the welds, the welds thereby being on the liquid side of the heat exchanger and the solder on the air side;

(j) heating said adjacent areas of the tubes and header plates to melt said solder and thereby coat the said adjacent areas of the tubes and header plates with solder to seal the air side of the welds at said adjacent areas against any leakage opening that may occur in the welds;

(k) removing said end supports from said core; and

(l) attaching a tube enclosing liquid tank to each of said header plates in fluid tight relation.

11. In making a weldment heat exchanger having an air side core of spaced tubes and interconnecting fins extending between liquid tanks, the method comprising:

(a) stacking a plurality of solder-coated tubes in a plurality of spaced sets with fins arranged between each adjacent pair of tube sets;

(b) arranging rigid end supports against the stack;

(c) applying compression to the resulting stack through said supports, the tubes having substantially coplanar ends projecting beyond the sides of the stack;

(d) securing said stack in an easily handled rigid assembly;

(e) applying a header plate to each side of the assembly having tube ends with said tube ends extending through corresponding holes in the header plates;

(f) gang welding the projecting ends to the exterior of said header plates by relatively moving said stack and a multi-end, automatic welder;

(g) applying a soldering flux to the resulting core assembly;

(h) applying heat at a temperature above the melting point of said solder over the outer surfaces of said core assembly to bond the fins and tubes together;

(i) applying a sealant over the adjacent junction areas of the tubes and header plates that are opposite to the location of the welds, the welds thereby being on the liquid side of the heat exchanger and the sealant on the air side;

(j) causing the sealant to substantially solidify to seal the air side of the welds at said adjacent areas against any leakage openings that may occur in the welds;

(k) removing said end supports from said core; and

(l) attaching a tube enclosing liquid tank to each of said header plates in fluid tight relation.

12. The method of claim 11 wherein said sealant is a solder and step (j) is performed by first melting the solder to thereby coat the adjacent areas of the tubes and header plates and thereafter allowing the solder to cool below its melting point.

13. The method of claim 11 wherein steps (a)-(l), inclusive, are performed sequentially.

14. In making a vehicular radiator having an air side core of spaced tubes and interconnecting fins extending between liquid tanks, the method comprising:

(a) stacking a plurality of tubes in a plurality of spaced sets with fins arranged between each adjacent pair of tube sets;

(b) arranging rigid end supports against the stack;

- (c) applying compression to the resulting stack through said supports, the tubes having substantially coplanar ends projecting beyond the sides of the stack;
 - (d) securing said stack in an easily handled rigid assembly;
 - (e) applying a header plate to each side of the assembly having tube ends with said tube ends extending through corresponding holes in the header plates;
 - (f) fusing the projecting ends to the exterior of said header plates by heating at least the junction areas of said tubes and said header plates to form a strong tube to header joint;
 - (g) bonding the fins and tubes together;
 - (h) applying a sealant over the adjacent junction areas of the tubes and header plates that are opposite to the location of said fused ends, the fused ends thereby being on the liquid side of the radiator and the sealant on the air side;
 - (i) causing the sealant to substantially solidify to seal the air side of the fused ends at said adjacent areas against any leakage openings that may occur in the fused ends;
 - (j) removing said end supports from said core; and
 - (k) attaching a tube enclosing liquid tank to each of said header plates in fluid tight relation.
15. The method of claim 14 wherein step (g) is performed after step (f).
16. The method of claim 14 wherein step (i) provides a secondary, relatively weak tube to header joint.
17. In making a radiator for a vehicle having a core of spaced tubes and interconnecting fins extending between liquid tanks, the method comprising:
- (a) stacking a plurality of solder-coated tubes in a plurality of spaced sets with fins arranged between each adjacent pair of tube sets to provide a stack;
 - (b) arranging end supports against the stack;
 - (c) applying compression to the stack through said supports, the tubes having substantially coplanar ends projecting beyond the sides of the stack;
 - (d) securing said stack in an easily handled rigid assembly;
 - (e) applying a header plate to each side of the assembly having tube ends with said header plate having a plurality of holes, said tube ends extending through said holes;
 - (f) welding said tube ends to the header plates with some or all of said welds being prone to defects to provide a core assembly;
 - (g) applying a soldering flux to said core assembly;
 - (h) applying heat at a temperature above the melting point of said solder over the outer surfaces of said core assembly to bond the fins and tubes together;
 - (i) contacting the adjacent junction areas of the tube ends and header plates with a melted solder having excellent capillary flow properties so that the solder with its excellent capillary flow properties fills defects in the welds to provide a leak-tight structure;
 - (j) removing said end supports from said core; and
 - (k) attaching a tube enclosing liquid tank to each of said

- header plates in fluid tight relation.
- 18. The method of claim 17 wherein said radiator has an air side and a liquid side and step (i) is performed over said junction areas on the air side.
- 19. In making a radiator for a vehicle having a core of spaced tubes and interconnecting fins extending between liquid tanks, the method comprising:
 - (a) stacking a plurality of tubes in a plurality of spaced sets of fins arranged between each adjacent pair of tube sets to form a stack;
 - (b) arranging the tube sets so that the tubes have substantially coplanar ends projecting beyond the sides of the stack;
 - (c) applying a header plate having a plurality of holes to each side of the assembly having tube ends so that said tube ends extend through respective ones of said holes;
 - (d) welding said tube ends to the header plates with some or all of said welds being prone to defects;
 - (e) bonding the fins and tubes together;
 - (f) contacting the adjacent junction areas of the tube ends and header plates with a sealant having excellent capillary flow properties so that the sealant with its excellent capillary flow properties fills defects in the welds to provide a leak-tight structure; and
 - (g) attaching a tube enclosing liquid tank to each of said header plates in fluid tight relation.
- 20. The method of claim 19 wherein said radiator has an air side and a liquid side and step (f) is performed over said adjacent junction areas on the air side.
- 21. The method of claim 19 wherein end supports are arranged against the stack and compression is applied to the stack through said supports prior to step (c).
- 22. The method of claim 19 wherein the tubes are solder-coated and a soldering flux is applied to the core prior to step (e) and heat is applied at a temperature above the melting point of the solder to bond the fins and tubes together.
- 23. In making a radiator for a vehicle having a core of spaced tubes and interconnecting fins extending between liquid tanks, the method comprising:
 - a. stacking a plurality of tubes in a plurality of spaced sets with fins arranged between each adjacent pair of tube sets to form a stack;
 - b. arranging the tube sets so that the tube ends project beyond the sides of the stack;
 - c. applying a header plate having a plurality of holes to each side of the assembly having tube ends so that said tube ends extend through respective ones of said holes;
 - d. fusing said tube ends to the header plate with some or all of the fusions being prone to defects;
 - e. bonding the fins and tubes together;
 - f. applying a sealant having excellent capillary flow properties over the adjacent junction areas of the tube ends and header plates to seal and fill the defects in said fusions; and
 - g. attaching a tube enclosing liquid tank to each of said header plates and fluid type relation.

* * * * *

UNITED STATES PATENT AND TRADEMARK OFFICE
CERTIFICATE OF CORRECTION

PATENT NO. : Re. 35,098

Page 1 of 2

DATED : November 28, 1995

INVENTOR(S) : Zalman P. Saperstein, et al.

It is certified that error appears in the above-identified patent and that said Letters Patent is hereby corrected as shown below:

On the title page, Inventors: [75] add:

Russell C. Awe, Brookfield, WI

- Claim 1: Col. 4, line 43, delete the phrase "end rigid" and insert the phrase "rigid end" therefor.
- Claim 11: Col. 6, line 21, delete the word "plurlity" and insert the word "plurality" therefor;
Col. 6, line 36, delete the word "multi-end" and insert the word "multi-head" therefor.
- Claim 13: Col. 6, line 59, insert a ")" after the "(a" and before the hyphen "-".
- Claim 14: Col. 7, line 6, delete the word "plant" and insert the word "plate" therefor.
- Claim 17: Col. 7, line 43, delete the word "spplying" and insert the word "applying" therefor.

UNITED STATES PATENT AND TRADEMARK OFFICE
CERTIFICATE OF CORRECTION

PATENT NO. : Re. 35,098

Page 2 of 2

DATED : November 28, 1995

INVENTOR(S) : Zalman P. Saperstein, et al.

It is certified that error appears in the above-identified patent and that said Letters Patent is hereby corrected as shown below:

- Claim 19: Col. 8, line 9, before the word "fins" delete the word "of" and insert the word "with" therefor;
- Claim 20: Col. 8, line 28, delete the word "clain" and insert the word "claim" therefor.

Signed and Sealed this
Seventh Day of May, 1996



Attest:

BRUCE LEHMAN

Attesting Officer

Commissioner of Patents and Trademarks