

[54] **FOLDING ICE-CREAM CARTON, CARTON BLANK, AND METHOD**

[75] **Inventor: Thomas W. Froom, Pittsford, N.Y.**

[73] **Assignee: Somerville Packaging Corporation, Newport News, Va.**

[21] **Appl. No.: 23,846**

[22] **Filed: Mar. 9, 1987**

Related U.S. Patent Documents

Reissue of:

[64] **Patent No.: 4,431,129**
Issued: Feb. 14, 1984
Appl. No.: 331,557
Filed: Dec. 17, 1981

U.S. Applications:

[62] **Division of Ser. No. 158,167, Jun. 10, 1980, Pat. No. 4,328,656, which is a division of Ser. No. 842,747, Oct. 17, 1977, Pat. No. 4,239,115.**

[51] **Int. Cl.⁴ B65D 5/02**
 [52] **U.S. Cl. 229/151**
 [58] **Field of Search 229/145, 146, 151; 206/624, 626, 631**

[56] **References Cited**

U.S. PATENT DOCUMENTS

1,143,745	6/1915	Bloomer	229/145
1,509,383	9/1924	Walter	229/33
2,367,008	1/1945	Davidson	229/33
2,367,780	1/1945	Inman	229/33
2,369,385	2/1945	Carruth et al.	229/16 A
2,496,043	1/1950	Farrell	
3,018,942	1/1962	Arneson	206/631
3,040,957	6/1962	Meyers	229/33
3,109,577	11/1963	Knipp	229/51
3,131,851	5/1964	Pace	206/624
3,144,980	8/1964	Larson	206/626
3,168,233	2/1965	Ignell	206/626
3,195,800	7/1965	Cote	229/33
3,197,114	7/1965	Holmes	229/51
3,206,915	9/1965	Anderson et al.	53/374
3,265,285	8/1966	Fanter	206/626
3,281,054	10/1966	Buttery et al.	229/145
3,315,870	4/1967	Barnes	206/624

3,353,740	11/1967	Outwater	206/624
3,506,184	4/1970	Barnes	229/145
3,543,997	12/1970	Michetti et al.	229/51
4,046,313	9/1977	Perry	206/611
4,239,115	12/1980	Froom	206/611

OTHER PUBLICATIONS

Marvel Carton.

Primary Examiner—Stephen P. Garbe
Attorney, Agent, or Firm—Shlesinger & Myers

[57] **ABSTRACT**

A carton or package for packaging semi-fluid material which can be hardened by freezing, such as ice cream, sherbet and the like, is formed from specially constructed integral carton blank and a special process for assembling the same. The carton blank has a front panel, a bottom panel, a rear panel, a cover panel, and a front cover sealing flap articulated one to the other in the order named with end-forming flaps and glue-flap extensions extending laterally therefrom adapted to be glued together to form inner and outer walls and side-cover flaps. The bottom outer wall-forming flap is glued to the inner wall-forming flaps by glue strips along the side edges of the latter, where they are joined to the front and rear panels, and the side-cover flap has a tuck-in tab adapted to be tucked in under the bottom outer wall-forming flap between the glue strips. The glue-flap extensions are adapted to fold over the side-cover flaps and to be glued thereto by an extension of the glue strip adjacent the front of the carton. In forming the carton or package, one end is closed first by folding in the side flap extensions, folding down the side-cover flap, applying the glue strips with the one adjacent the front of the carton extending up over the folded-down side-cover flap, then folding up the bottom outer wall-forming flap to a position overlying the tuck-in tab and folding in the glue-flap extensions over the glue strip on the side-cover flap and causing adherence between the glue and the folded-in flaps. The tube thus formed is then filled and the other end closed in a like manner.

14 Claims, 10 Drawing Sheets

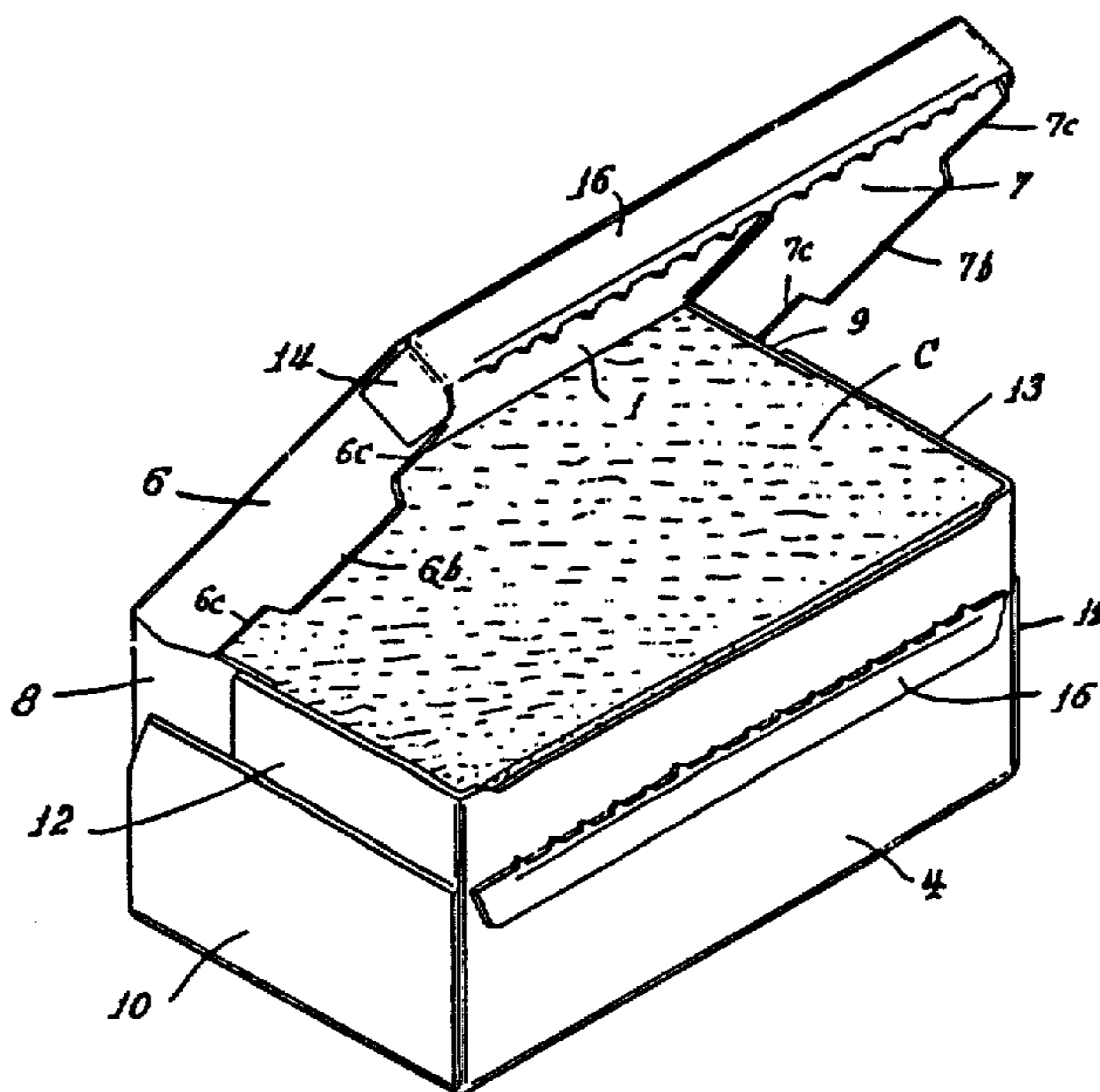

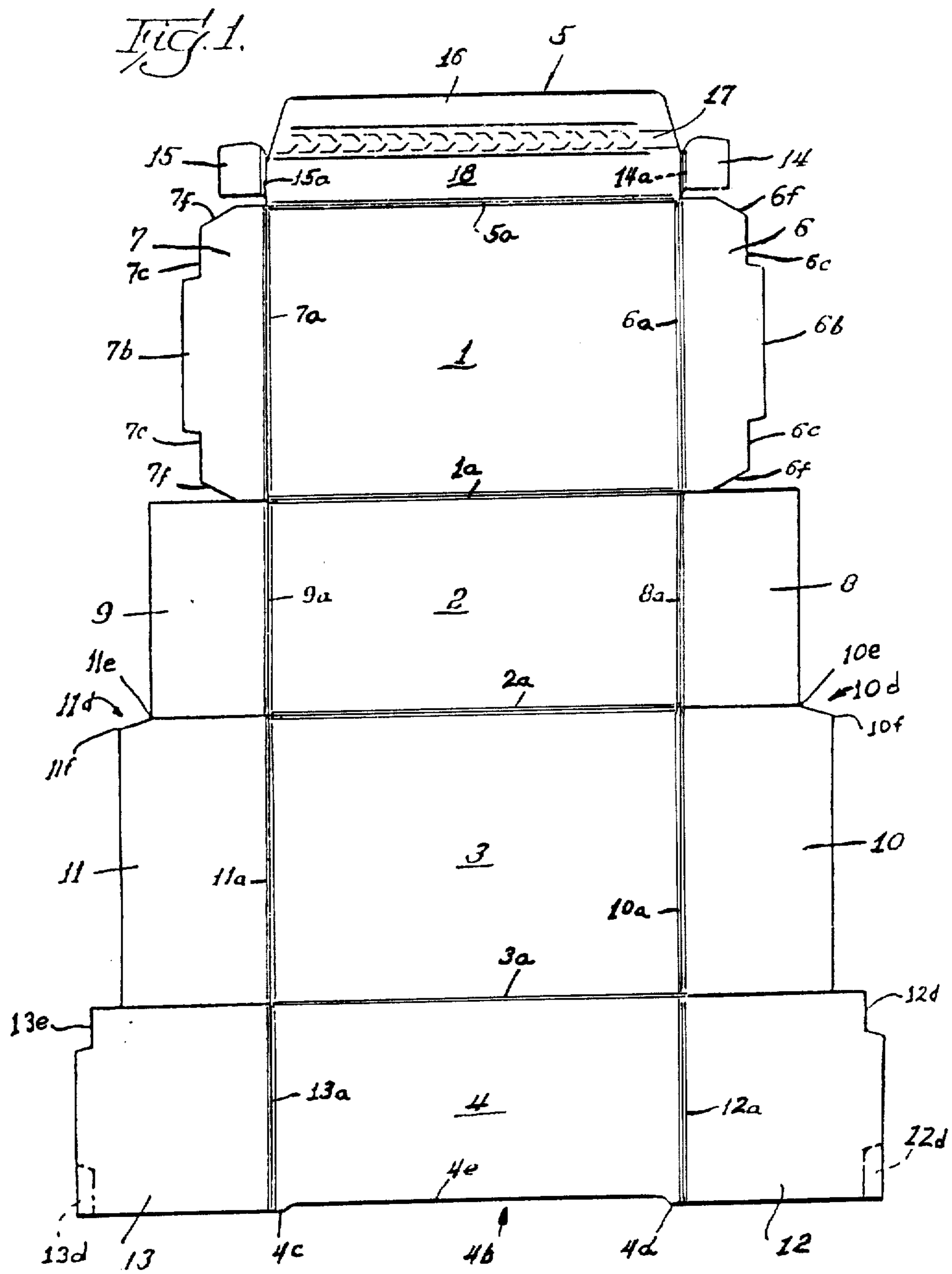

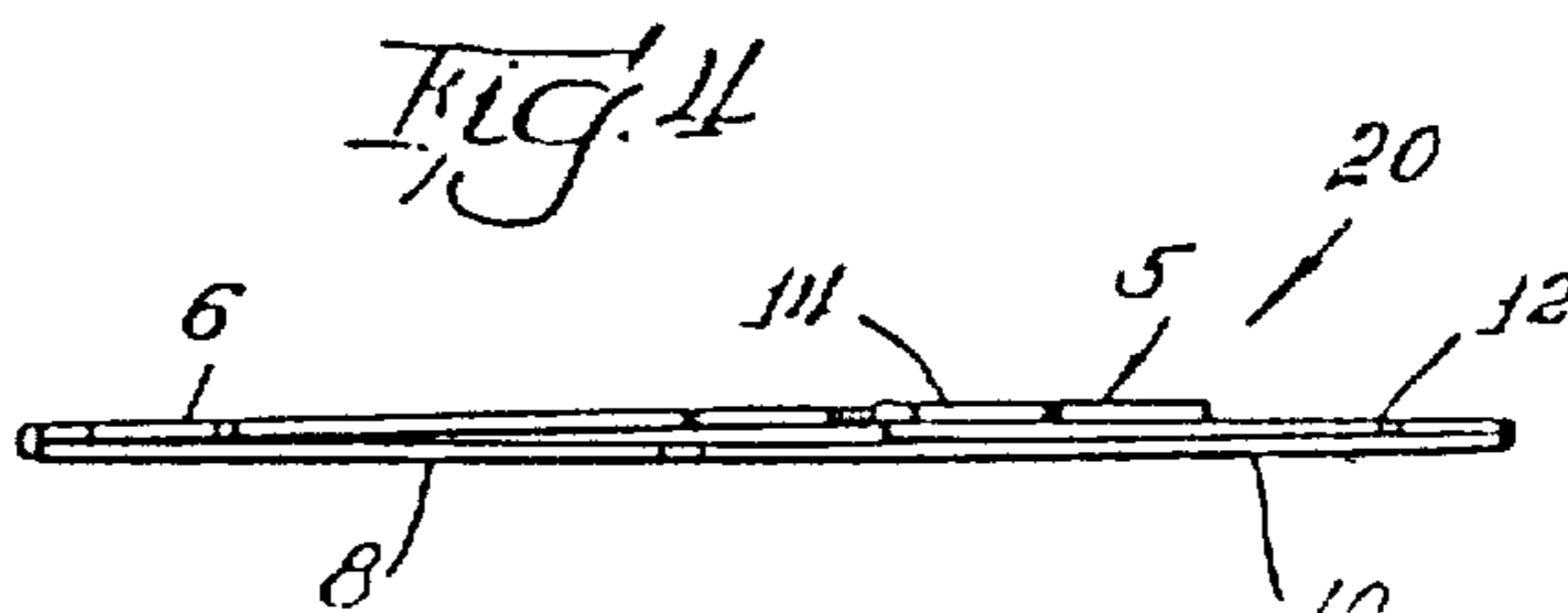
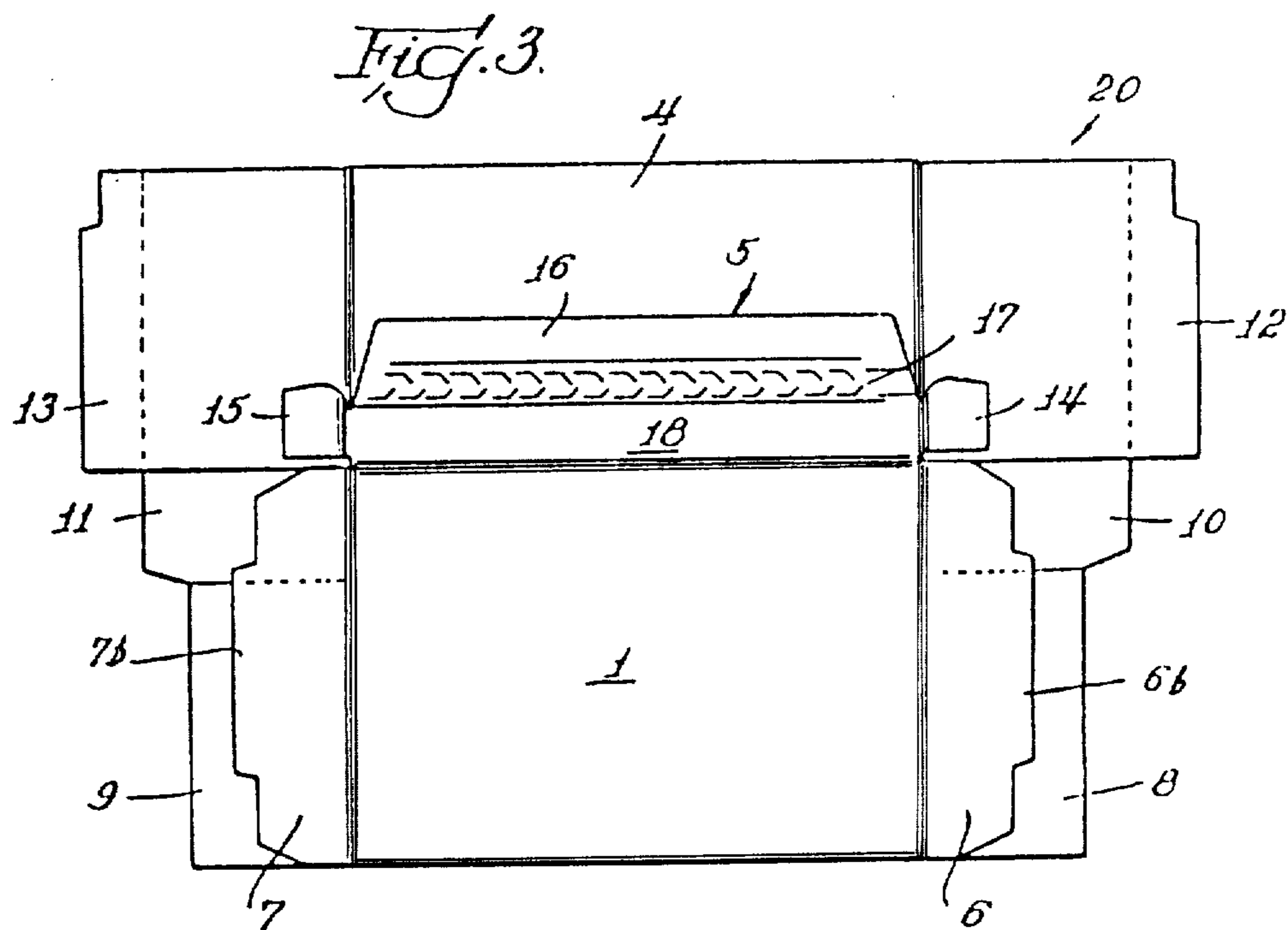
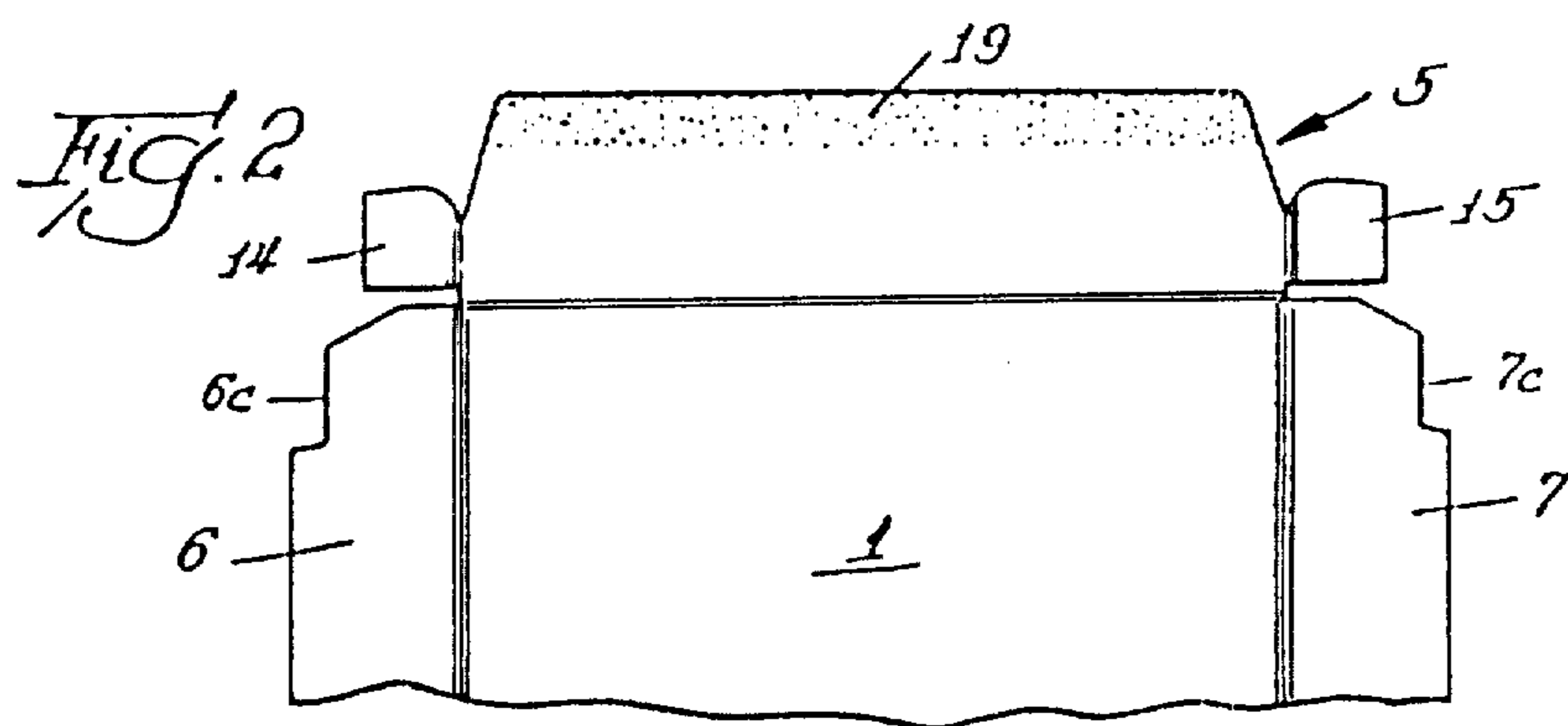

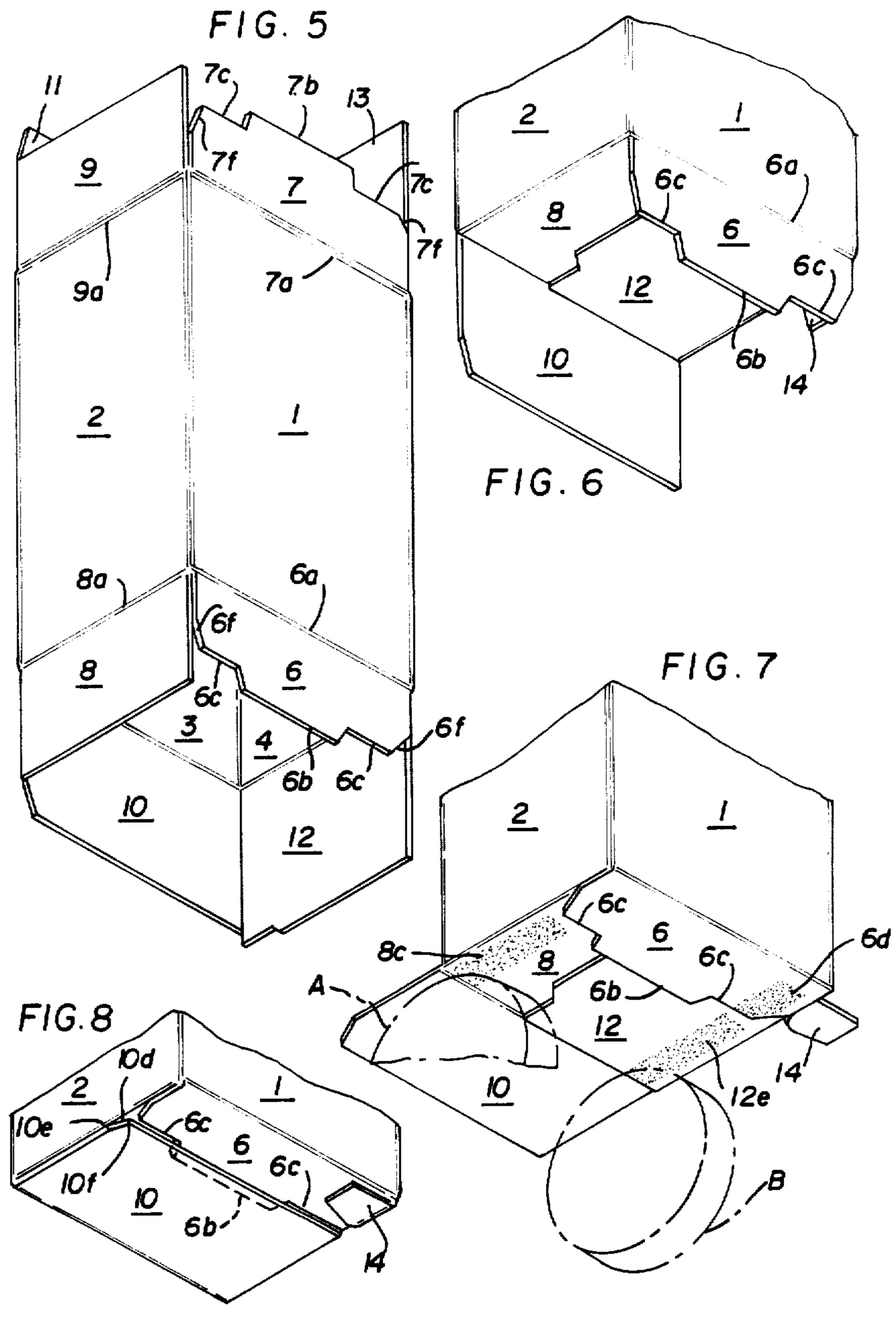

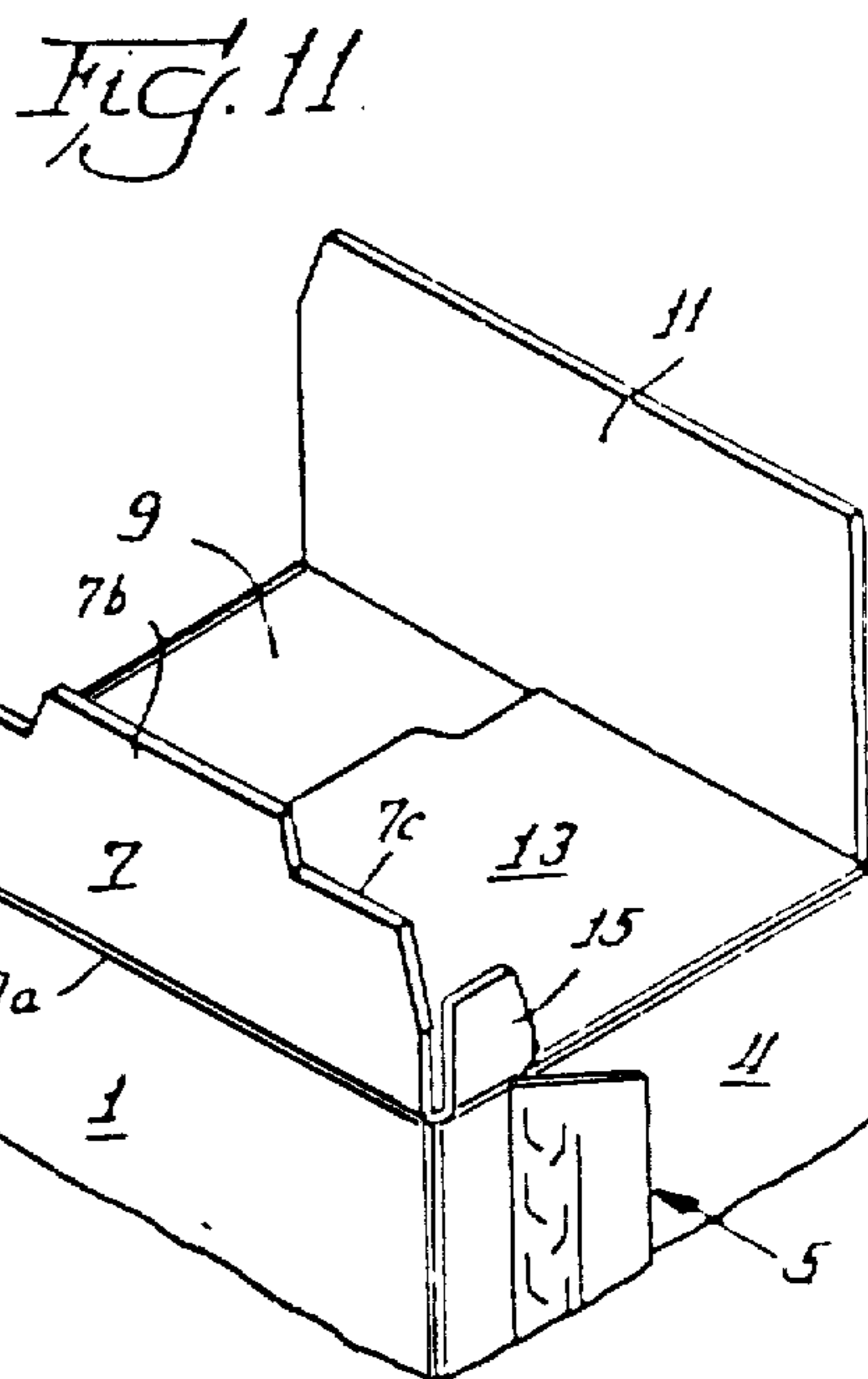
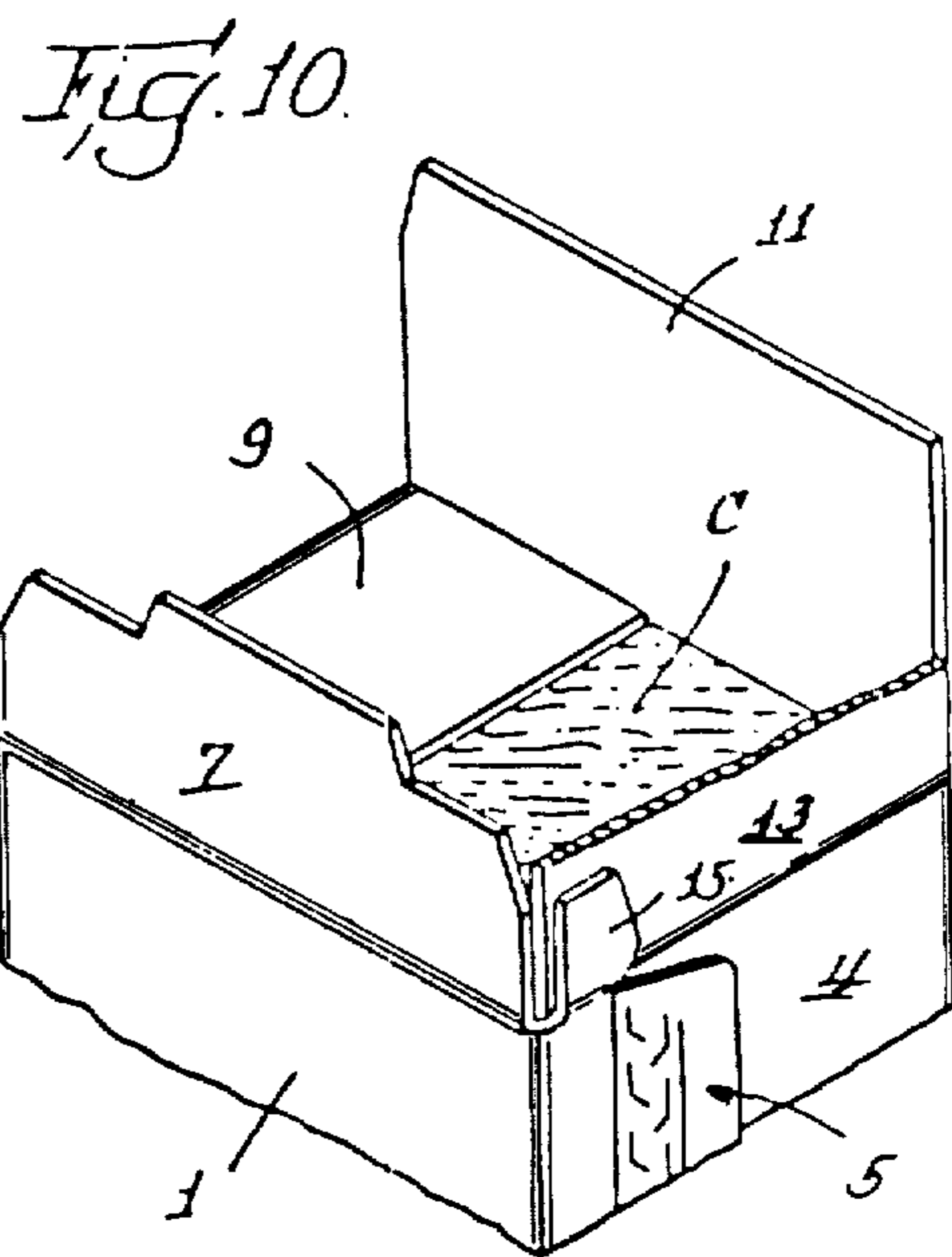
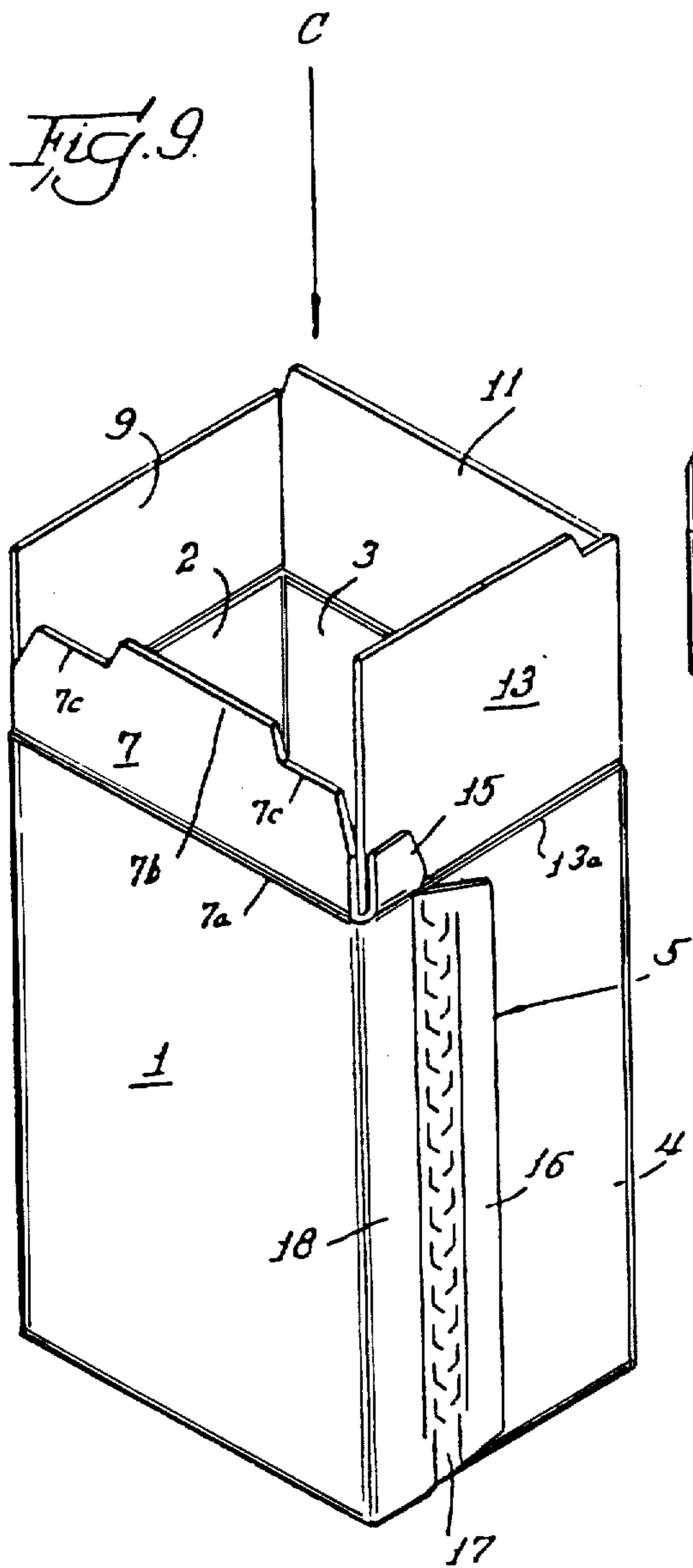

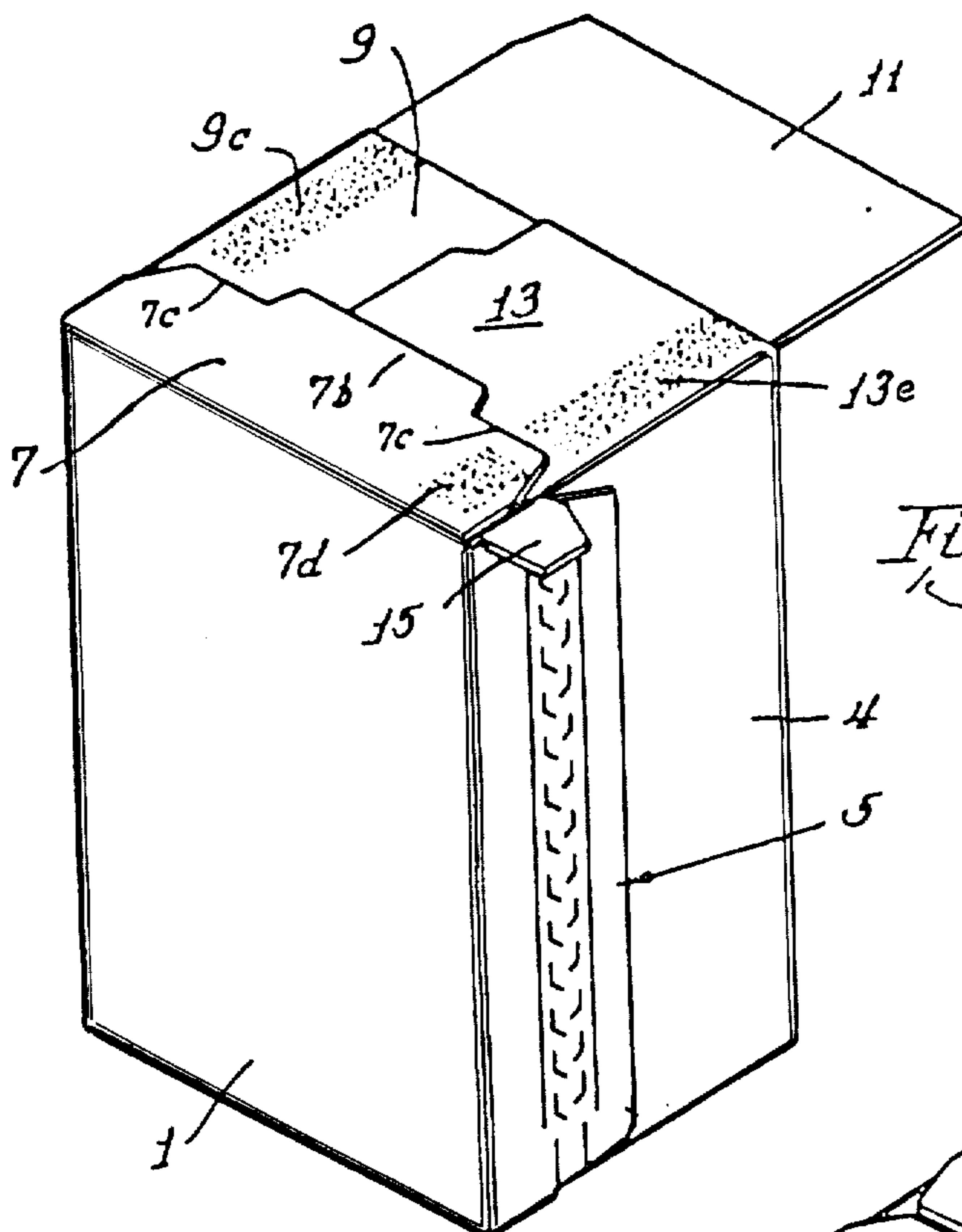

Fig. 12.

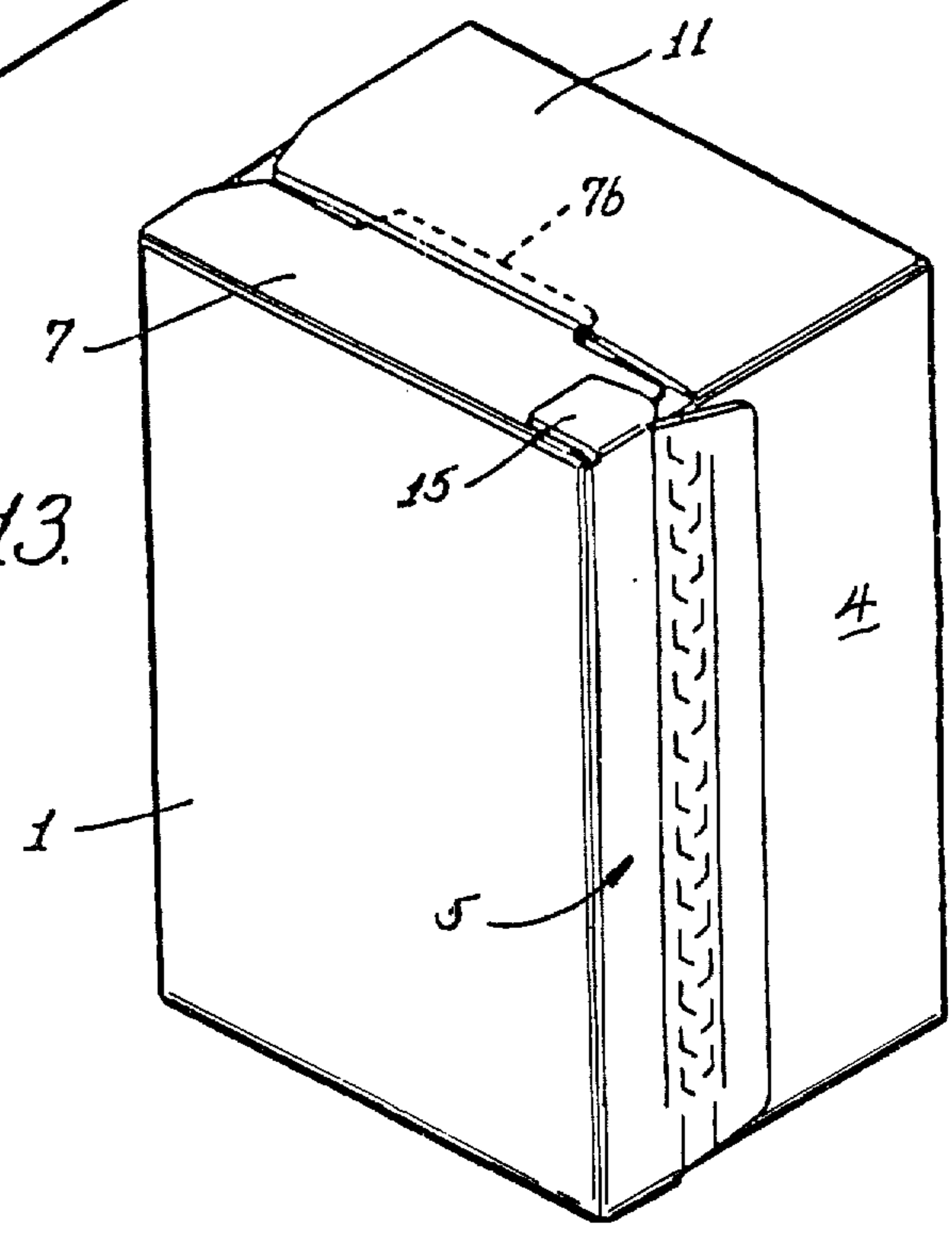

Fig. 13.

Fig. 14

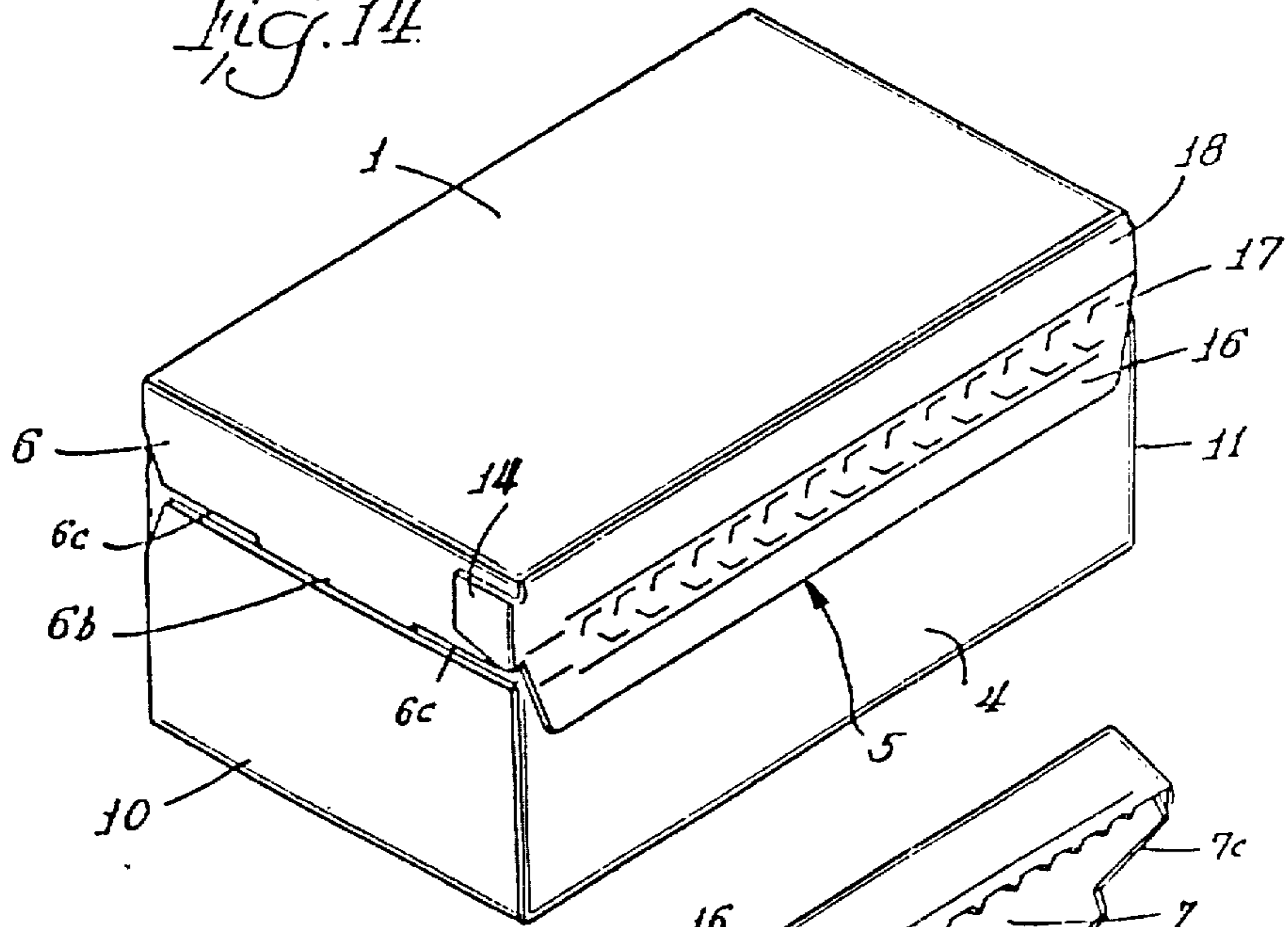

Fig. 15

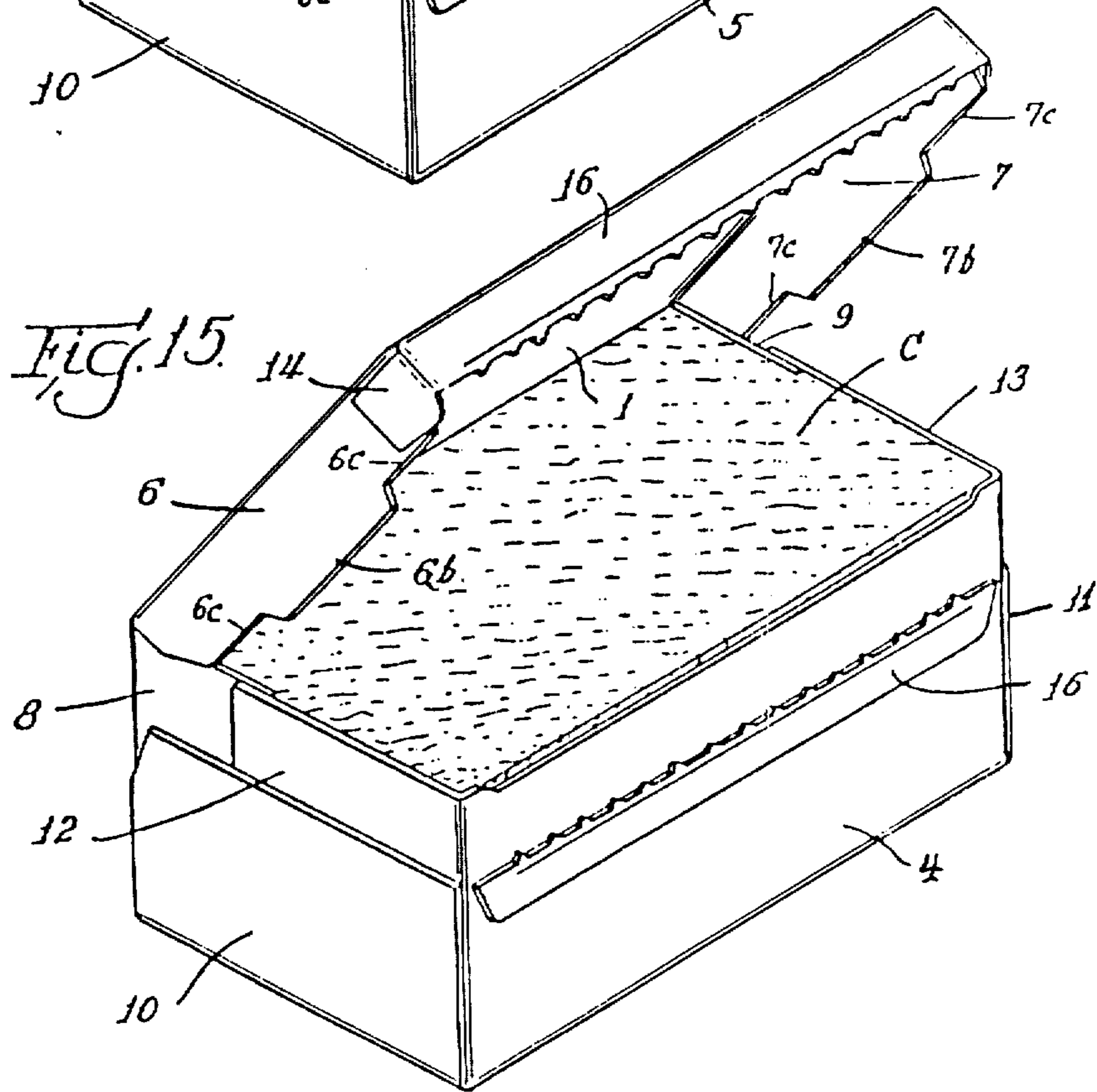

Fig. 16.

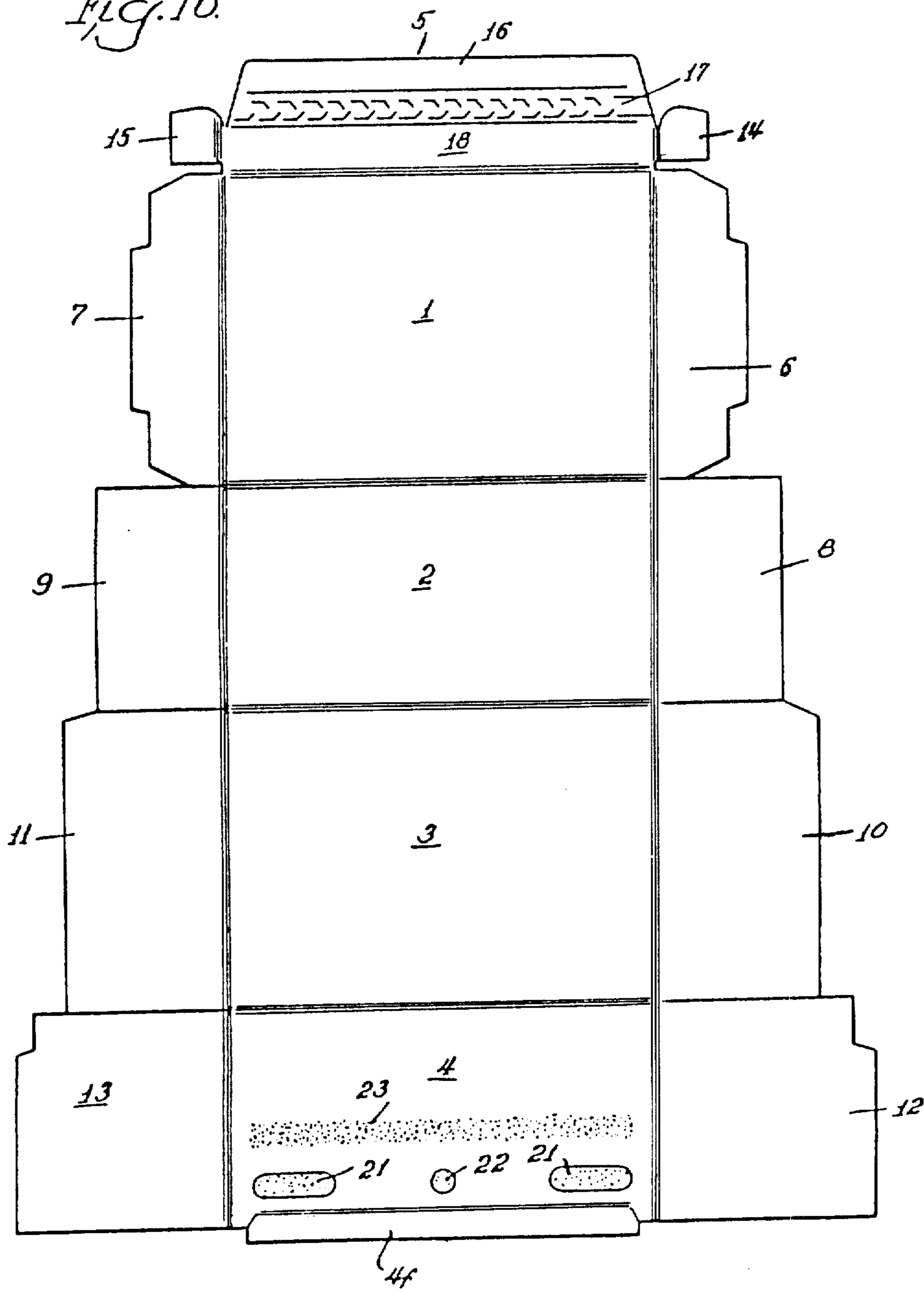
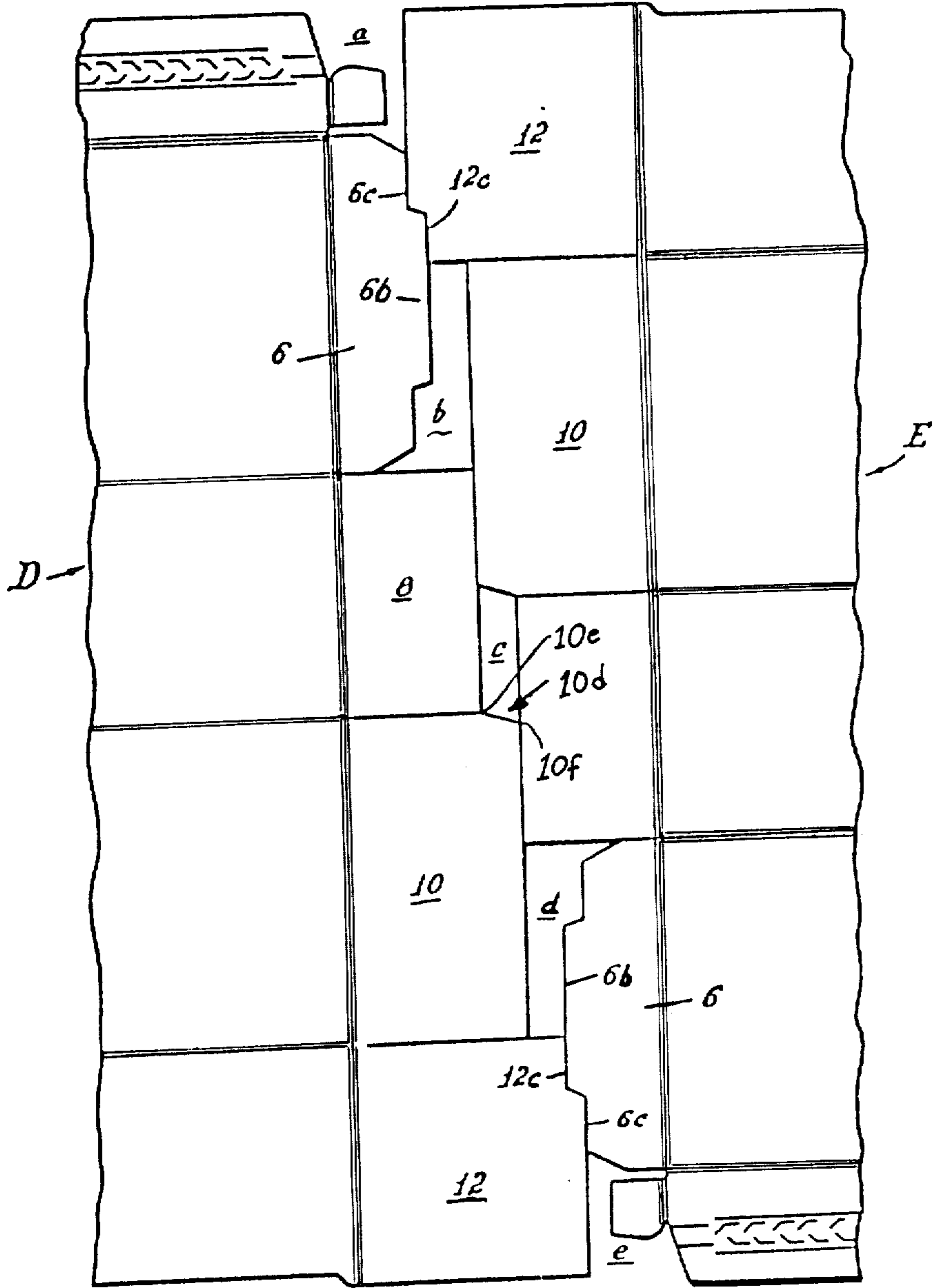

Fig. 17



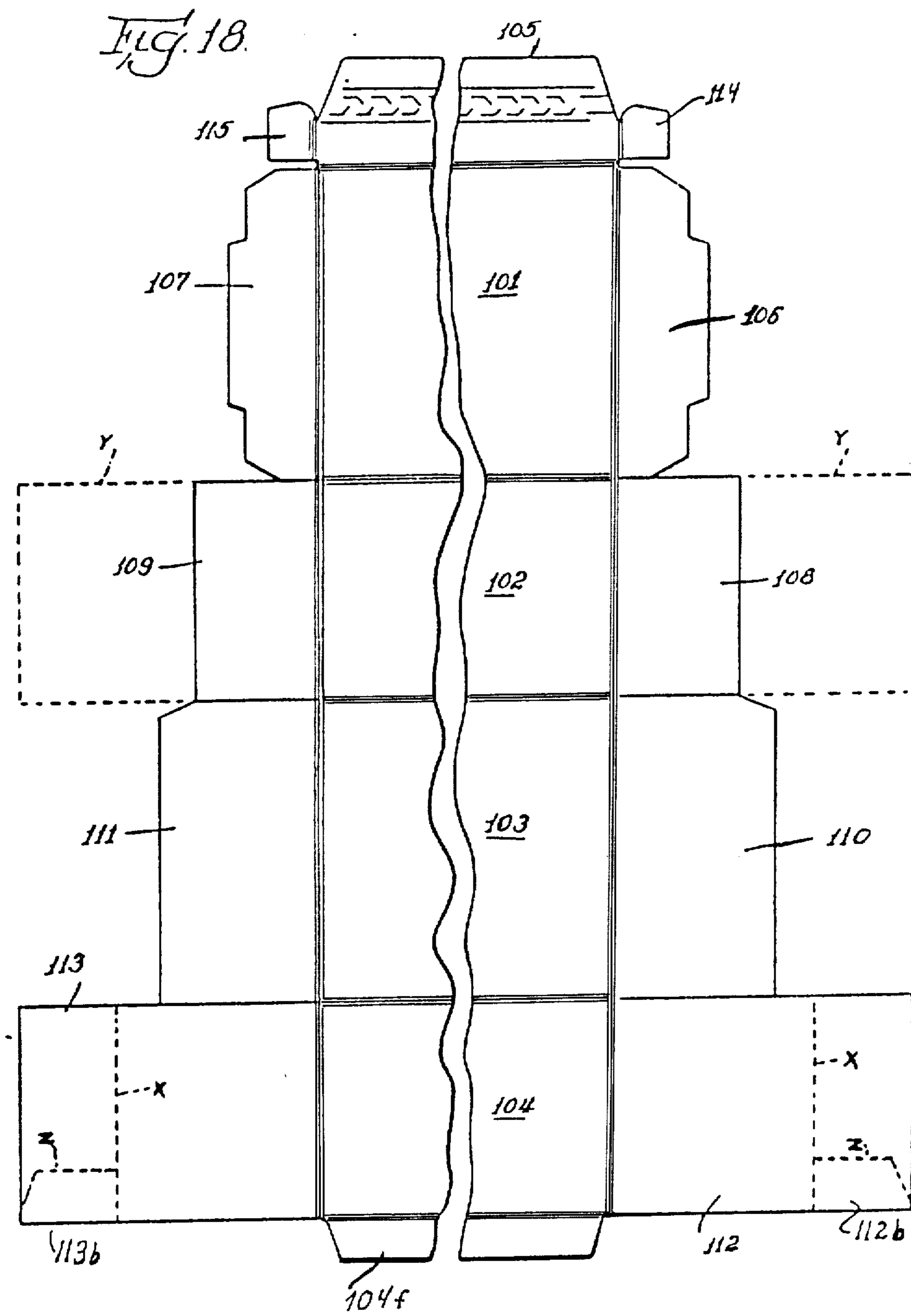

Fig. 19.

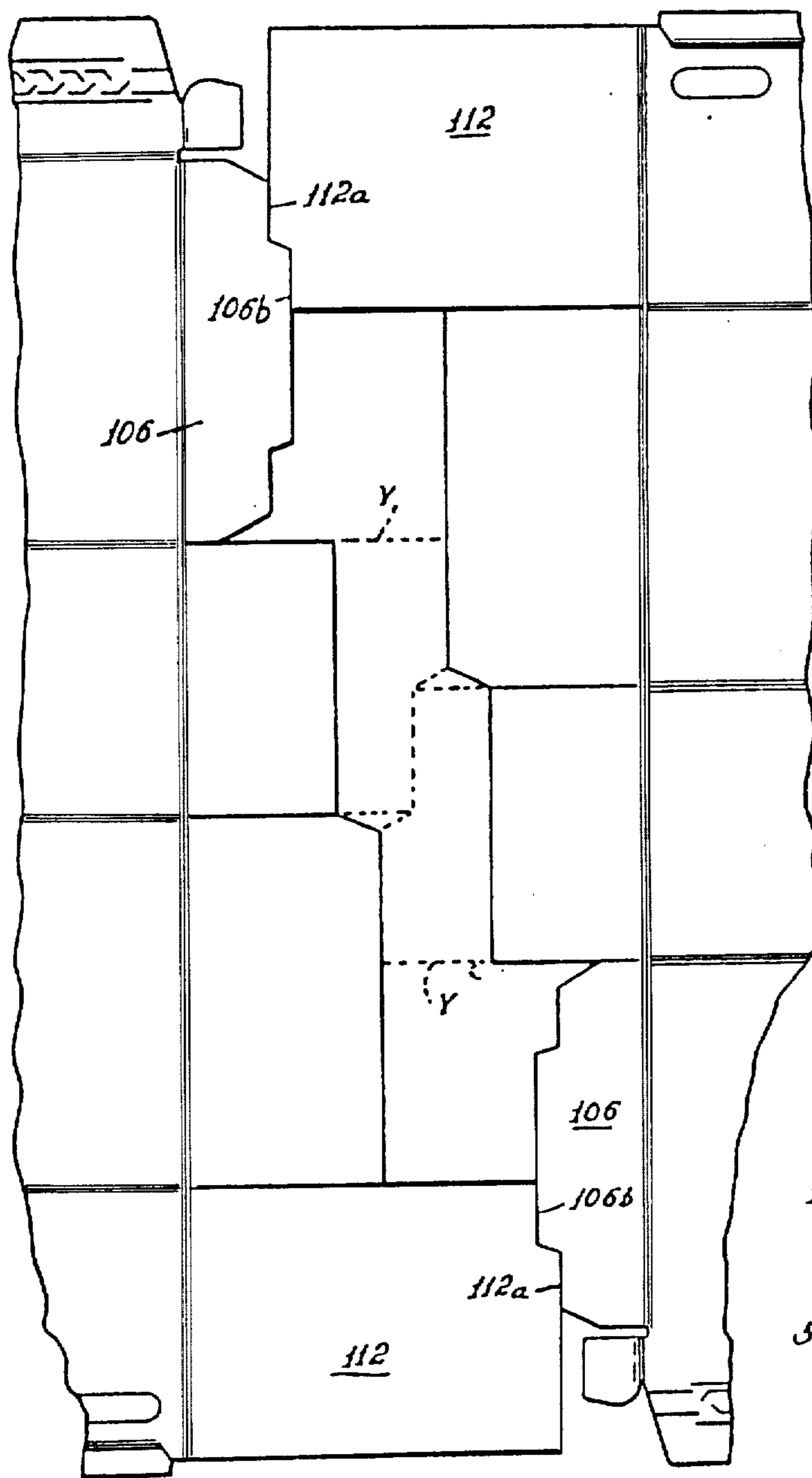

Fig. 21.

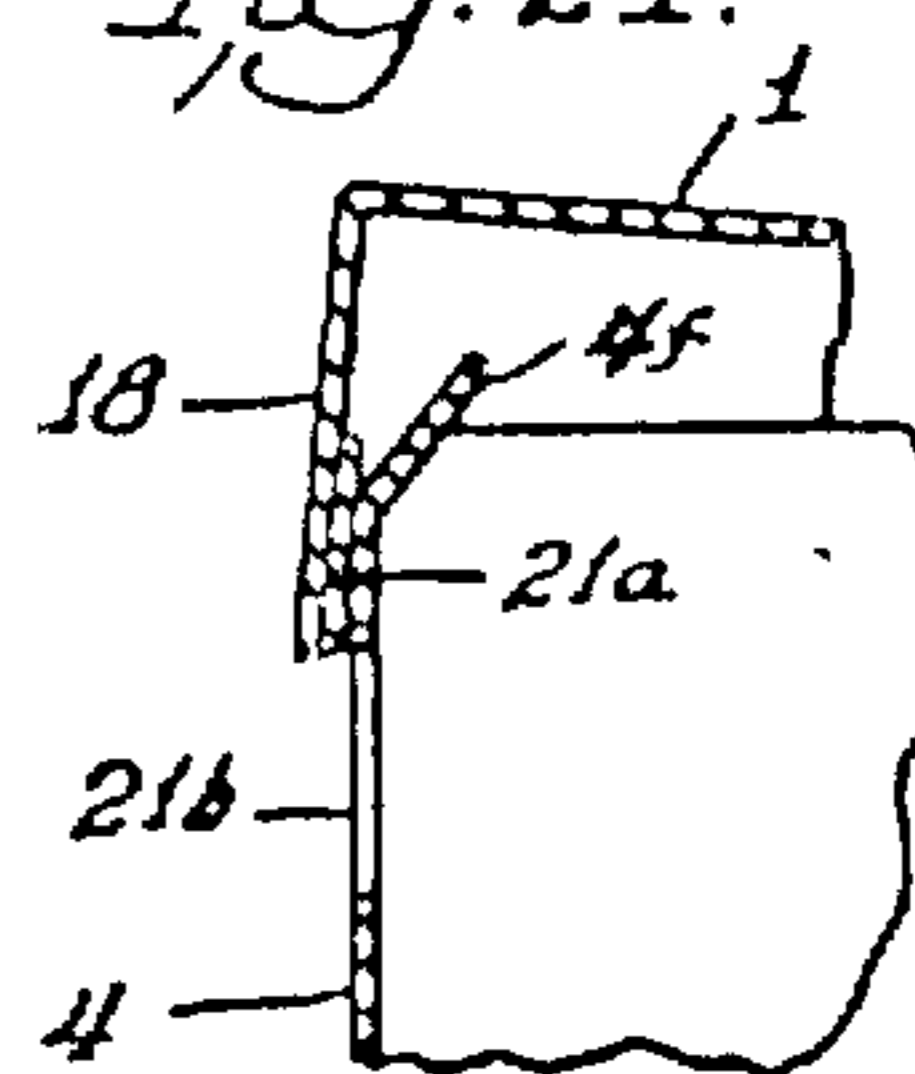
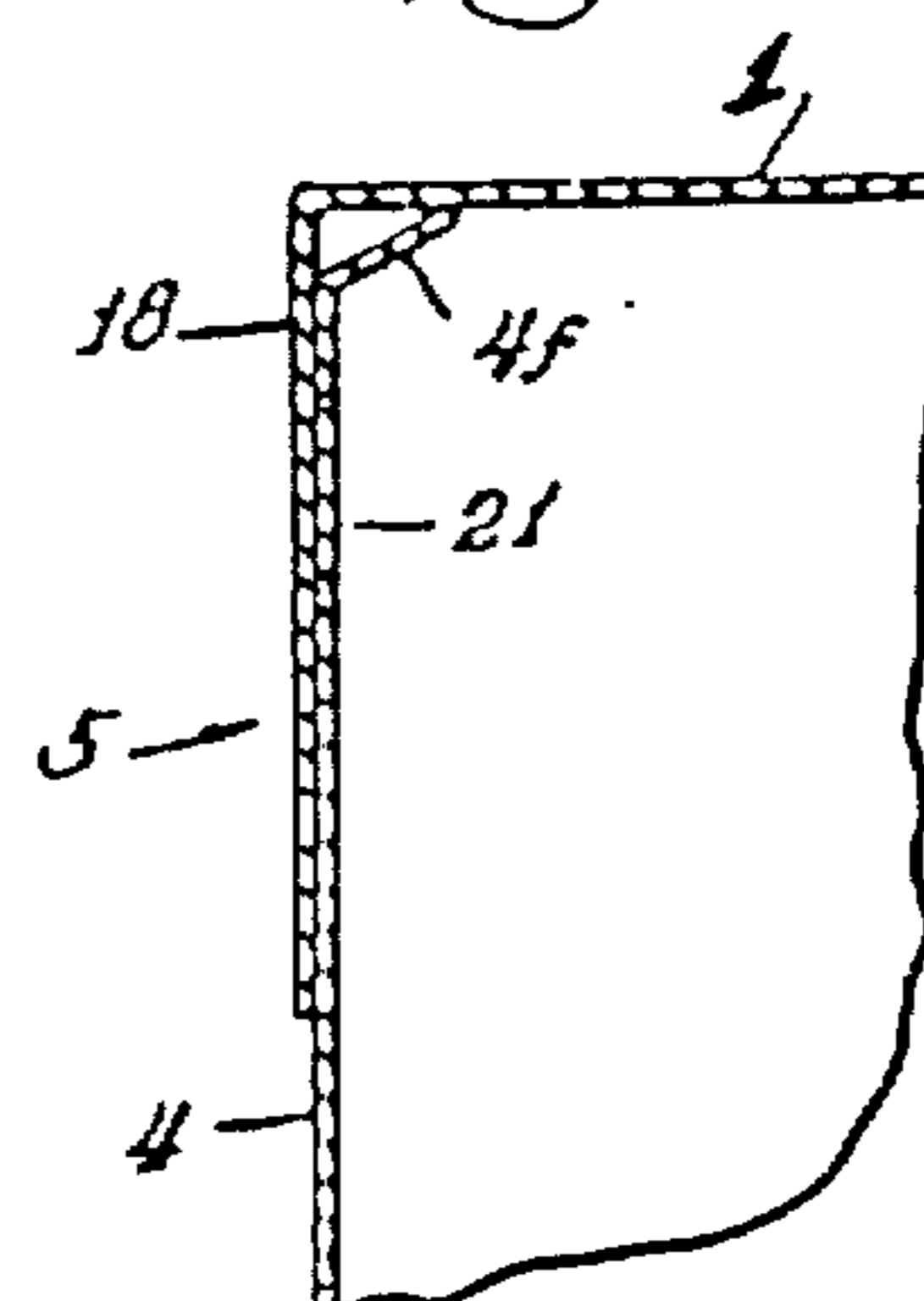

Fig. 20.



FOLDING ICE-CREAM CARTON, CARTON BLANK, AND METHOD

Matter enclosed in heavy brackets [] appears in the original patent but forms no part of this reissue specification; matter printed in italics indicates the additions made by reissue.

This is a division of application Ser. No. 158,167, filed June 10, 1980, now U.S. Pat. No. 4,328,656 which is a division of application Ser. No. 842,747, filed Oct. 17, 1977, now U.S. Pat. No. 4,239,115, issued Dec. 16, 1980.

FIELD OF INVENTION AND PRIOR ART

This invention relates to the art of packaging and is particularly directed to a novel carton blank, a novel carton, a novel package and novel methods of preparing the same, which embodies into an ice-cream carton the salient features of earlier U.S. Pat. No. 3,040,957, which embodies all of the salient features of U.S. Pat. No. 1,509,383. In the prior art carton, however, the bottom outer wall forming flap overlaps the entire side cover flap and is glued to the inner wall-forming flaps by a horizontal glue strip adjacent the bottom of the side cover flap. Also, the glue flap extensions have glue strips applied to them and the side cover flaps are overlapped and are glued to the glue flap extensions. The result of these two features is a carton which is not well suited for semi-liquid material such as ice cream and the like, since when it melts it will tend to leak out between the various flaps forming the end walls of the carton. Moreover, the application of a horizontal glue strip across the inner end wall-forming flaps requires a support for those flaps, such as a mandrel or a filled carton.

OBJECTS OF THE INVENTION

It is an object of the invention to provide improvements in the packaging of semi-solid materials such as ice cream and the like. It is a further object of the invention to provide a carton or package which is simple to manufacture and which is essentially leak-proof. It is a further object of the invention to provide an improved method for making cartons and packages of the class described. It is a further object of the invention to provide novel tube cartons in which the bottom can be formed and sealed without a mandrel. It is still a further object of the invention to provide a package which has improved openability and improved reclosability and which affords improved protection to the contents thereof after opening. It is a further object of the invention to provide novel carton blanks which are adapted for manufacture from paperboard sheet stock in high-speed cutting and scoring machines. It is a further object of the invention to provide such a blank in which there is a [minimal] *minimum* of stock wastage in the cutting and scoring operation and economy of raw material usage. Further objects are to avoid disadvantages of the prior art and to obtain such advantages as will appear as the description proceeds.

BRIEF DESCRIPTION OF THE INVENTION

The invention relates to improvements in the packaging of semi-fluid materials such as ice cream and the like and it is particularly directed to an improved carton or package and improved tube carton and improved carton blank as well as to an improved method of making the same.

In accordance with one aspect of the invention, a carton tube or sleeve is made from an integral carton blank having a front panel, a bottom panel, a rear panel, a cover panel and a front cover sealing flap articulated one to the other in the order named in which the front cover sealing flap is attached to the front panel by a frangible seam and in which the closed end is formed of inner-end wall forming flaps attached to the front and rear panels and by top and bottom outer end wall-forming flaps, the first of which is a side cover flap attached to the end of the cover panel and the second of which is attached to the bottom panel, which carton tube is characterized in that the bottom outer end wall forming flap is glued to the inner end wall forming flaps by glue strips extending along the edges thereof which are attached to and adjacent the front and rear panels and in that the side cover flap has a tuck-in tab adapted to be inserted under the bottom outer end wall forming flap between the glue strips. Advantageously the glue strips extend from the bottom of the inner end wall forming flaps and the bottom of the bottom outer end wall-forming flap up to the top of the latter.

This effectively seals the end walls from the bottom up to the top of the bottom end wall-forming flap, thus precluding leakage between the inner end wall-forming flaps and the bottom outer end wall-forming flap. Advantageously the front cover sealing flap has a lateral glue-flap extension which is adapted to be glued to the side cover flap.

Also advantageously the frangible seam on the front cover sealing flap has a tear strip.

The tube or sleeve carton as formed, with the bottom or one end sealed, is filled with the material to be packaged and the other end, which has the same types of flap extensions, is closed and sealed in a like manner.

The several panels and the front cover sealing flap are separated by horizontal score lines and the flaps and the panels are separated by vertical score lines. It will be understood that the terms vertical and horizontal are used merely for the purposes of orientation and that if the blank is rotated 90 degrees, the vertical score lines become horizontal score lines and vice versa. The side flap extensions are separated from the front cover flap also by vertical score lines which are displaced with respect to the other vertical score lines so that the distance between them is greater than the distance between the other vertical score lines by that required for the glue-flap extension to overlap the side cover flap and thus allow the side cover flap to lie flat against the inner end wall formed by the inner end wall-forming flaps. The closer the cover flap lies along the end wall, the less leakage there will be.

In assembling the tube carton from the integral paperboard blank thus described, the front cover sealing flap is glued or otherwise fastened to the front panel, thereby forming a tube which when erected has a rectangular cross section and, when collapsed, is flat. The collapsed tube coming from stock is opened up and the inner end wall-forming flaps are folded in. The side-cover flap is then folded down over the folded-in inner end wall-forming flaps. Glue strips are then applied to the glue strip areas on the outer edges of the inner wall formed by the folding in of the inner wall-forming flaps and the one adjacent the front of the carton tube is extended up over the folded down side-cover flap. The bottom end wall-forming flap is then folded up over the tucked in tab of the side-cover flap and the glue flap extensions are folded in over the glue strip on the side

cover flap, and the bottom outer wall-forming flap and the glue-flap extension are caused to adhere to the glue strips to form a sealed end.

Desirably, when the glue strips are applied, the bottom outer end wall-forming flap and the glue-flap extension are bent out of the way and a hot-melt glue is applied by rollers or guns, and other means, starting either at the top or at the bottom of the application at the front of the carton extending up over the folded-down side-cover flap, and the application at the side that is adjacent to the rear panel either starting or terminating at or adjacent to the bottom of the side-cover flap. The tube carton thus formed is then filled and the other end closed in the same manner. The blanks according to the invention are adapted for making either top-opening or side-opening cartons. In the form shown, the top and bottom panels are wider than the rear and front panels, so that the resulting carton is a top-opening carton. Thus, when the tear strip is torn, the cover, which has a front cover flap which is glued to the side-cover flaps by the glue-flap extensions, can be raised up to expose the contents and then closed again with the tuck-in tabs tucked in to hold the cover securely in place.

In accordance with a preferred form of the invention, the side flaps, including the glue-flap extension, progressively diminish in size from the front panel to the front cover sealing flap so that, when two flat blanks are side by side in reverse position, the inner wall-forming flap attached to the front panel abuts the side-cover flap of the other blank, and so on, so that there is very little scrap lost in the cutting and scoring of the blanks from a continuous sheet of stock. Advantageously, the inner and outer corners of the inner wall-forming flaps attached to the front panels are cut away to accommodate the tuck-in tab.

If desired, however, one or the other of the inner wall-forming flaps can be extended to fit snugly into or to cover the end of the carton tube. In the latter case, the outer edge of such a flap desirably is short enough so that it does not overlies the glue strip area, otherwise it must be glued to the underlying flap.

Advantageously, the front panel has a top edge cut down to form corner posts at the sides thereof so that the cover fits firmly and snugly against the carton after it is opened.

In some cases, it is desirable to provide a fold-in flap on the top edge of the front panel adapted to fold in under the cover and thus improve the seal when the cover is closed. When this flap is attached to the cut-down edge and the cover is closed, it will angle up to prevent leakage or seepage of the product between the front panel and the front cover flap.

If desired, the front cover flap can be glued to cut-scored portions of the front panel to hold it flat and firm in the collapsed tube. This has a further advantage that, when the tear strip is removed and the cover flap pulled forward, the pull-outs will be left on the inside of the cover flap and thus form detents when the cover is closed to hold the cover in closed position. The fold-in flap on the front cover in particularly of advantage in this case, because it acts as a ramp for the cut-outs to slide over when the cover is closed and as a spring to pull into contact with the hole from which they were cut out.

The carton blanks of the invention have the advantage that the tube carton and package can be formed therefrom without the use of mandrels and, as compared with methods requiring mandrels, result in sub-

stantial savings both in the machinery required for forming, filling, and closing the package and in savings in the floor space required to house the same.

DETAILED DESCRIPTION OF THE DRAWINGS

In the drawings:

FIG. 1 is a plan view of a carton blank.

FIG. 2 is a detail view of a modified form of FIG. 1.

FIG. 3 is a collapsed carton tube formed of FIG. 1.

FIG. 4 is an end view of FIG. 3.

FIG. 5 is an isometric view of the opened-up tube of FIG. 3.

FIG. 6 is a partial view of FIG. 8, showing the inner end wall-forming flaps folded in.

FIG. 7 is a partial view showing the cover side flap folded in, remaining flaps folded out, hot-melt glue strips applied, and stylized applicators therefor.

FIG. 8 is a view in which the remaining flaps of FIG. 7 are folded into place to form the closed end of the carton tube.

FIG. 9 is an isometric view of the closed end of the carton tube in position to be filled.

FIG. 10 is a partial view of the filled carton tube with one of the inner end wall-forming flaps folded in over the contents.

FIG. 11 is a partial view showing the other inner end wall-forming flap folded in.

FIG. 12 is an isometric view showing additionally the cover side flap folded in and the other flaps folded out, together with glue strips of hot-melt glue applied as in FIG. 7.

FIG. 13 shows the finished package in which the folded-out flaps of FIG. 12 have been folded over into contact with the glue strips.

FIG. 14 is an isometric view of the finished package of FIG. 13.

FIG. 15 is an isometric view showing the cover raised.

FIG. 16 is a plan view of a modified carton blank.

FIG. 17 is a plan view illustrating how the carton blanks of FIG. 1 are cut and scored from stock sheet material.

FIG. 18 is a plan view of a modified carton blank.

FIG. 19 is a plan view of another modified carton blank showing how this blank is cut and scored from stock sheet material.

FIG. 20 is a detailed section of a carton assembled from the blank of FIG. 16.

FIG. 21 is a partial section of the modification of FIG. 20 showing the cover detached and partially raised.

DETAILED DESCRIPTION OF THE INVENTION

Referring now particularly to FIG. 1, there is shown a carton blank having panels 1, 2, 3, and 4, articulated in that order by horizontal score lines 1a, 2a, and 3a. The panel 1, which is the cover-forming panel, has articulated thereto sealing flap 5 by the horizontal score line 5a.

Extending laterally from the panels 1, 2, 3, and 4, are side-forming panels 6 through 13, which are articulated with the panels by means of the vertical score lines 6a through 13a. The flaps 6 and 7 are side-cover flaps. Flaps 8 and 9, which extend laterally from the rear panel 2, are inner end wall-forming flaps. Flaps 10 and 11, which extend laterally from the bottom panel 3, are

partial outer end wall-forming flaps. And flaps 12 and 13, which extend laterally from the front panel 4, are inner end wall-forming flaps.

The cover sealing flap 5 has a glue tab 16 connected to the cover flap 18 by tear strip 17. Projecting laterally from the cover flap 18 are glue-tab extensions 14 and 15, which are articulated therewith by vertical score lines 14a and 15a. The vertical score lines 7a, 9a, 11a, and 13a are aligned in an essentially common vertical score line and, similarly, with respect to score lines 6a, 8a, 10a, and 12a. The score lines 14a and 15a, however, are displaced laterally with respect to the other vertical score lines, so that the distance between the score lines 14a and 15a is greater than the [distancebetween] distance between the score lines 6a and 7a such that, in the erected carton, the glue-tab extensions 14 and 15 overlie the cover side flaps 6 and 7.

In FIG. 2, the tear strip 17 is omitted and a frangible glue 19 is applied so that the cover can be readily broken away from the front panel.

In FIGS. 3 and 4, the glue tab 16 is glued to the front panel 4, to form a collapsed tube, which can be opened up into the tube shown in FIG. 5.

The side-cover flaps 6 and 7 are provided with tuck-in tabs 6b and 7b. These tabs extend over the greater portion of the bottom edge of the side-cover flaps 6 and 7, but are inset from the ends thereof as shown at 6c and 7c, for a purpose which will become apparent in the description of the assembly of the carton.

In assembling the carton, the inner end wall-forming flap 8, which is attached to the rear panel 2, is folded in first and then the inner end wall-forming flap 12, which is attached to the front panel 4, is folded in to overlie flap 8, as shown in FIG. 6, or vice versa. Then the side-cover flap 6 is folded down, the outer end wall-forming flap 10 and the glue-tab extensions 14 are folded back out of the way and hot-melt glue applicators A and B apply hot-melt glue strips 6d, 12e and 8c. The hot-melt applicator, B, first contacts the side-cover flap 6 and deposits the glue strip 6d and then continues on to deposit the glue strip 12e. Concurrently, as the glue strip 12e is applied, the glue strip 8c is applied by glue applicator A. The applicators A and B are programmed so that the glue strip 6d is applied first and then the glue strip 8c and 12e applied simultaneously. If desired, the glue strip 6d can be applied independently of the application of the glue strip 12e. Also, if desired, the glue strips can be applied in the reverse order, that is, from the bottom panel upward. Either the glue applicators A and B can be mounted to move over the carton tube of FIG. 7, or the glue applicators A and B can be stationary and the partially-assembled tube of FIG. 7 passed under or over or, in any event, passed into contact with the glue applicators A and B.

Advantageously, the partially assembled tube cartons can be moved along a continuous belt (not shown), with the open end resting on the belt and the end to be sealed, uppermost. In such case, it is desirable that the movement be in the direction of the folded-back flap 10, so that any tendency for the flaps 8 and 12 to be displaced will be corrected by the flap 6, which is folded down over the folded-in flaps 8 and 12.

Since the glue strips are applied adjacent the score lines, the front and rear panels provide support for the flaps so that the sealing of the ends can be effected without a mandrel or before the carton is filled.

The next step is to fold in the outer wall-forming flap 10 and the glue-flap extension 14 into contact with the glue strips, as shown in FIG. 8.

It will be observed that the outer wall-forming flap 10 and the side-cover flap 6 are proportioned so that the flap 10 covers the tuck-in tab 6b and essentially abuts the inset portions 6c, thereby forming the outer wall of the end of the carton.

The partially-assembled carton, with one end sealed and the other end open, is passed under a filling station, as shown in FIG. 9, where a semi-solid material at ambient temperature C, which suitably is ice cream, sherbet, or the like, is introduced into the open-ended tube until it is filled to the level of the score lines. The inner end wall-forming flap 9 is then folded in, as shown in FIG. 10, followed by the folding in of the overlapping end wall-forming flap 13, or vice versa, as shown in FIG. 11. The sealing process is then carried out, as shown in FIG. 12, in the same way that the other end was sealed, as shown in FIG. 7, to form a finished package, as shown in FIGS. 13 and 14.

When the tear strip 17 is removed, the cover can be raised, as shown in FIG. 15, and again closed, with the tuck-in tabs 6b inserted between the outer end-wall flap 10 and the inner end-wall flap 12.

The insets 6c, as best seen in [FIGS.] FIG. 7 [and 12], are inset just enough to accommodate the glue strips 8c and 12e. Similarly, the insets 7c, as best shown in FIG. 12, are inset just enough to accommodate the glue strips 9c and 13e.

The glue strips 8c and 12e extend down to the bottom of the inner wall-forming flaps 8 and 12 and, if desired, partly onto the outer end wall-forming flap 10 so that, when the flap 10 is folded up, a leak-proof seal between the flaps 8, 10, and 12 is obtained. Similarly, in connection with FIG. 12, a leak-proof or leak-resistant seal is obtained between the flaps 9, 11, and 13.

By virtue of the fact that the glue-tab extensions 14 and 15 are on the outside of the side-cover flaps 6 and 7, the side-cover flaps 6 and 7 lie flat against the inner end wall and enhance both the strength of the cover and the leak-proof character of the package. In the prior art, the glue-flap extensions are folded under the side-cover flaps and are glued to the underside thereof, thus placing a short layer of paperboard between the side-cover flap and the end wall. This separates the side-cover flap from the end wall and promotes leakage. In the invention, on the other hand, the glue-flap extensions overlap the side-cover flap and are glued to the outside thereof, so that the side-cover flap lies flat against the end wall. This minimizes leakage because the more extensive the flat surface-to-surface contact between the side-cover flaps and the end walls, the less tendency there is for leakage to occur. In FIG. 1, it will be observed that the front panel is cut down at 4b to provide shoulders 4c and 4d adjacent the score lines 12a and 13a. Thus, the top edge 4e of the front panel 4 is slightly below a line extending from the shoulder 4c to the shoulder 4d and parallel thereto. This cooperates with the outside sealing of the glue-tab extensions 14 and 15, further to enhance the leakproof feature of the container.

This feature can still further be enhanced by attaching to the top lip 4e, a flap as shown at 4f, in FIG. 16, the function and construction of which will be described more particularly in connection with FIG. 16.

In FIG. 16, there is shown a modification which has the flap 4f and cut-scored pull-outs 21 and 22 located in the portion of the front panel 4 which underlies the

front-cover flap 18. Glue is applied to these pull-outs 21 and 22 and to the portion of the panel underlying the glue tab 16 so that, when the front cover-sealing flap 5 is sealed to the front panel, the whole sealing flap will be held in flat contact with the front panel 4, from the collapsed position shown in FIG. 3, through all the subsequent operations. Then when the tear strip 17 is removed and the cover raised, the pull-outs 21 and 22 will adhere to the cover and not seriously interfere with the opening of the cover. Furthermore, when the cover is closed, the pulled-out portions will engage the holes from which they were pulled out and act as detents to hold the cover closed. This can more readily be seen from FIG. 21, where the pulled-out portion 21 is attached to the front-cover flap 18, in position to enter the hole 21b. Also, it will be observed in FIGS. 20 and 21, when the flap 4 is bent in under the cover 1, it will angle up so that its lip engages the inner surface of the cover panel 1, as shown in FIG. 20. When the cover is raised, as shown in FIG. 21, the tab 4f tends to spring up so that when the cover is again closed and the pull-out 21a seated in the hole 21b, a tight and intimate seal is effected.

If desired, the pull-outs 21 and 22, or the equivalent thereof, can be in the flap 4f, or 104f. Alternatively, the tab 4f, or 104f, can be spot-glued to the cover panel.

Even when the pull-outs 21 and 22 are not employed, the flap 4f will have a similar effect due to the friction between the side and front cover flaps of the cover panel 1, with the carton sides. The flap 4f also makes it possible to effectively eliminate the pull-outs 21 and 22 entirely. The flap 4f has its edge in contact with the inner surface of the cover panel, as shown in FIG. 20, and thus, effectively prevents leakage in a filled carton, even if the top portion of the front panel is separated from the front cover panel. The flap 4f thus eliminates the need for a double glue line.

FIG. 17 illustrates how the carton blanks of the invention are particularly adapted to high-speed production from continuous sheet or roll stock and high-speed cutting and scoring machines. It will be observed that the laterally-extending flaps are progressively wider, so that when the blank E is placed in juxtaposition to blank D in reverse order, the wider flaps of blank D are opposite the narrower flaps of blank E, and so on. Thus, the inner end wall-forming flap 12 abuts the side-cover flap 6 and has a cut-out portion 12c which abuts tuck-in tab 6b. The outer wall-forming flap 10 abuts the inner wall-forming flap 8; the inner wall-forming flap 8 abuts the outer wall-forming flap 10; the side-cover flap 6 abuts the inner end wall-forming flap 12, which also has a cut-out portion 12c which abuts and is complementary with the tuck-in tab 6b; just as the cut-out portion 12c of the other blank is complementary with the tuck-in tab 6b. It will thus be observed that, essentially, the only scrap material is that shown by the portions a, b, c, d, and e. The result is a carton blank of the smallest area of any glue-sleeve ice-cream carton known in the art.

It will be observed more clearly in FIGS. 1 and 17, that the outer end-forming flaps 10 and 11 have their outer inner corners, i.e., the corners which are adjacent the rear panel, flaps 8 and 9, cut off, as shown at 10d and 11d. The purpose of this is best seen in FIG. 8, where the bottom corner 10e is firmly affixed to the glue strip 8c and the upper corner 10f, if not firmly attached to the glue strip 8c, is still inset from the panel 2, so that it is not an easily engaged corner which could be pulled up

during the making or handling of the finished package or carton.

In FIG. 18, there is shown a modification in which one or the other or both of the inner end wall-forming flaps is extended beyond the dotted line x or, to the dotted lines y, so that it occupies the full end of the carton tube, and thus overlies completely the contents of the tube. It is of advantage, however, that only one of these flaps be so extended, since if the overlying flap does not terminate short of the glue area, it will have to be joined (glued) thereto by a separate glue line applied along the edge of the underlying flap adjacent to the panel to which it is attached. Otherwise, the outer end wall-forming flap 110 would be glued to the free end of the overlapping inner end wall-forming flap, so that the effective seal would not be obtained without the extra glue line.

The inner end wall-forming flaps 112 and 113 can be cut on the dotted lines Z-[Y] X to provide the flap extensions 112b and 113b. When the flaps 112 and 113 so cut away overlie flaps 108 and 109, the extensions 112b and 113b will extend under the cover flaps 106 and 107 to the rear panel. This, coupled with the glue-flap extensions 114 and 115 overlying the side-cover flaps 106 and 107, make for continuous flat contact between the side-cover flaps 106 and 107 and the end wall formed by the folded-in end wall-forming flaps. If desired, the extensions 112b and 113b can be glued to the underlying flaps. The stock for the extensions 112b and 113b can be obtained largely from the waste area "a" of FIG. 17.

In this figure and in FIG. 19, the parts corresponding to the parts of FIG. 1 bear the same reference numerals, plus 100.

In FIG. 19, there is illustrated a modification of FIG. 18, in which the extended underlying inner end wall-forming flaps 112 have cut-outs 112a which are complementary with the tuck-in tabs 106b, so that this modification, too, can be easily formed in a continuous manner with high-speed cutting and scoring machines without too much loss of stock.

The side-cover flaps 6 and 7 have their corners cut off at 6f and 7f to avoid sharp corners which otherwise would tend to curl up.

As shown in FIG. 1, the outer inner corners of flaps 12 and 13 are cut out, as shown at 12c. This has the advantage that the overlap of flaps 12 and 13 with flaps 8 and 9 at the bottom of the carton is minimal. This results in a more leak-proof carton. The same advantage can be obtained at the top by cutting out the outer corners of the flaps 12 and 13, as shown in dotted lines, at 12d and 13d. When this is done, the flaps 12 and 13 have a minimal overlap with flaps 8 and 9 at both the top and the bottom and the result is that there is less likelihood of the contents seeping out of the package.

It is to be understood that the invention is not to be limited to the exact details of operation or structure shown and described, as obvious modification and equivalents will be apparent to one skilled in the art.

I claim:

1. An integral blank for forming a top-opening carton having a front panel, a bottom panel, a rear panel, a cover panel, and a front cover sealing flap; said panels being articulated to one another in the order named, said front cover sealing flap being articulated to said cover panel, and said front cover sealing flap being adapted to overlie said front panel and to be sealed thereto to form said panels into a tube having a rectangular transverse cross section in opened-up position;

said front and rear panels having laterally-projecting, inner end wall-forming flaps articulated thereto; said bottom panel having a laterally-projecting, outer end wall-forming flap articulated to a side thereof and adapted to be bent up to a position to overlie said inner end wall-forming flaps; said cover panel having a laterally-extending side cover flap articulated to a side edge thereof and adapted to overlie the inner end wall-forming flaps when the carton is erected; and the front cover sealing flap having an extension articulated to a side edge thereof by a score line, which extension is adapted to be adhered to said side cover flap to form, with said cover panel, a cover hinged to said rear panel and adapted to overlie the [side] inner end wall-forming flaps and front [panels] panel of the assembled carton; the improvement in which said extension is attached to the end of said front cover sealing flap adjacent said side-cover flap by a vertical score line offset sufficiently to permit the said extension to overlie the side-cover flap in the erected carton and to be adhered thereto whereby, in the assembled carton, the side cover flap lies flat against the outermost inner end wall-forming flap has a short adhesive strip which lies under the said extension and adheres the extension to the outer surface

2. A package which comprises a filled closed-end tube made from a blank according to claim 1, in which at least one end is closed by the cover side flap overlying the folded-in inner end wall-forming flaps, by the outer end wall-forming flap overlying and being adhered to the inner end wall-forming flaps by linear adhesive strips adjacent the outer edges thereof which do not extend above the top edge of the outer end wall-forming flap and in which the folded-down side cover flap has a short adhesive strip which lies under the said extension and adheres the extension to the outer surface of said side cover flap, whereby said side cover flap lies flat against the outermost inner end wall-forming flap surfaces throughout the length thereof, said short adhesive strip lying in line with the adhesive strip adjacent the front panel.

3. An integral carton tube having front, cover, rear, and bottom panels and having a closed end which is formed by inner end wall-forming flaps which project from said front and rear panels, a bottom panel outer end wall-forming flap which projects from said bottom panel, and a side cover flap which projects from said cover panel, with the side cover flap overlying and lying flat against the outermost surface of said inner end wall-forming flaps, said cover panel being adhered to said front panel by means of a front cover flap which has an extension which overlies said folded-down side cover flap and is adhered thereto, said extension being attached to the end of said front cover flap adjacent said side-cover flap by a vertical score line offset sufficiently to permit the said extension to overlie the side cover flap, whereby the side cover flap lies flat against the outermost inner end wall-forming flap surfaces [said last-named flap] substantially throughout the length of said side cover flap.

4. A filled package made from an integral carton blank having a front panel, a bottom panel, a rear panel, a cover panel, and a front cover sealing flap articulated one to another in the order named, in which the front cover sealing flap is attached to the front panel and in which both ends are closed, each of which ends comprises inner end wall-forming flaps attached to said front and rear panels and [top] cover and bottom panel outer end wall-forming flaps, the [top] cover one of

which is a sidecover flap attached to the end of the cover panel and the bottom one of which is attached to the end of the bottom panel, in which the bottom panel outer end wall-forming flaps are adhered to said inner end wall-forming flaps by linear adhesive strips extending only along the edges thereof which are articulated to and adjacent said front and rear panels and in which the side-cover flaps have tuck-in tabs inserted under said bottom panel outer end wall-forming flaps between the adhesive strips and lie flat against the outermost inner end wall-forming flap surfaces [said last-named flap] substantially throughout the length of said side cover flaps.

5. A closed-end carton tube made from an integral carton blank comprising a front panel, a bottom panel, a rear panel, a cover panel, and a front cover sealing flap articulated one to another in the order named, and having a rectangular transverse cross-section, in which the cover sealing flap is attached to the front panel, and in which the closed end comprises inner end wall-forming flaps attached to said front and rear panels and [top] cover and bottom panel outer end wall-forming flaps, the [top] cover one of which is a side cover flap attached to the cover panel and the bottom one of which is attached to the bottom panel, said bottom panel outer end wall-forming flap being adhered to said inner end wall thereof immediately adjacent said front and rear panels and said side-cover flap having a tuck-in tab underlying said bottom panel outer end wall-forming flap between the adhesive strips and lying flat against the outermost inner end wall-forming flap surfaces [said last-named flap] substantially throughout the length of said side cover flap.

6. The integral blank of claim 1 wherein one of said inner end wall-forming flaps is longer than the other of said inner end wall-forming flaps and, when the carton is erected, overlies said other of said inner end wall-forming flaps, the two inner end wall-forming flaps being of such relative lengths that, when the carton is erected, the free end edge of the longer one is spaced from the free end edge of the shorter one.

7. The integral blank of claim 6 wherein said inner end wall-forming flaps are articulated to said front and rear panels at fold lines and, when the carton is erected, the free end edge of the overlying inner end wall-forming flap is substantially closer to the free end edge of the underlying inner end wall-forming flap than it is to the fold line of said underlying flap.

8. The integral blank of claim 1 wherein the front cover flap extension, the side cover flap, the rear panel inner end wall-forming flap, the outer end wall-forming flap, and the front panel inner end wall-forming flap are all progressively wider in a step-wise fashion in the order named.

9. The integral blank of claim 8 wherein said side cover flap has a tuck-in tab at the edge thereof and said front panel inner end wall-forming flap has a cut-out portion which is complementary in shape to the shape of a portion of said tuck-in tab, and wherein said front cover flap extension, said side cover flap, said inner end wall-forming flaps, and said outer end wall-forming flap have widths such that, when two of said blanks are juxtaposed in side-by-side reverse order, the front panel inner end wall-forming flap of one blank touches the side cover flap of the other blank with the cut-out portion of the front panel inner end wall-forming flap touching the tuck-in tab of the other blank, the outer end wall-forming flap of the one blank touches the rear panel inner end wall-forming flap of the other

11

blank, the rear panel inner end wall-forming flap of the one blank touches the outer end wall-forming flap of the other blank, and the side cover flap of the one blank touches the front inner end wall-forming flap of the other blank with the tuck-in tab of the one blank touching the cut-out portion of the front panel inner end wall-forming flap of the other blank, whereby, when said blanks are cut from a stock sheet, a minimal amount of scrap results.

10. The integral blank of claim 8 in which the dimensions of said flaps are such that, when two of said blanks are juxtaposed in side-by-side reverse order, the free end of said front panel inner end wall-forming flap of one blank abuts the free end of said side cover flap of the other blank, the free end of said outer end wall-forming flap of the one blank abuts said rear panel inner end wall-forming flap of the other blank, the free end of said rear panel inner end wall-forming flap of the one blank abuts the free end of said outer end wall-forming flap of the other blank, and the free end of said side cover flap of the one blank abuts said front panel inner end wall-forming flap of the other blank.

11. The filled package of claim 4 wherein, at each of the ends of the package, one of said inner end wall-forming flaps is longer than and overlies the other of said inner end

12

wall-forming flaps, the two inner end wall-forming flaps being of such relative lengths that the free end edge of the longer one is spaced from the free end edge of the shorter one.

12. The filled package of claim 11 wherein said inner end wall-forming flaps are articulated to said front and rear panels at fold lines and the free end edge of the overlying inner end wall-forming flap is substantially closer to the free end edge of the underlying inner end wall-forming flap than it is to the fold line of said underlying flap.

13. The closed-end carton tube of claim 5 wherein, at the closed end, one of said inner end wall-forming flaps is longer than and overlies the other of said inner end wall-forming flaps, the two inner end wall-forming flaps being of such relative lengths that the free end edge of the longer one is spaced from the free end edge of the shorter one.

14. The closed-end carton tube of claim 13 wherein, said inner end wall-forming flaps are attached to said front and rear panels at fold lines and the free end edge of the overlying inner end wall-forming flap is substantially closer to the free end edge of the underlying inner end wall-forming flap than it is to the fold line of said underlying flap.

* * * * *

25

30

35

40

45

50

55

60

65

UNITED STATES PATENT AND TRADEMARK OFFICE
CERTIFICATE OF CORRECTION

PATENT NO. : Re 33,010
DATED : August 8, 1989
INVENTOR(S) : Thomas W. Froom

It is certified that error appears in the above-identified patent and that said Letters Patent is hereby corrected as shown below:

Claim 1, column 9, lines 23 and 24, "has a short adhesive strip which lies under the said extension and adheres the extension to the outer surface" should read --surfaces substantially throughout the length of said side cover flap.--

Signed and Sealed this
First Day of March, 1994



BRUCE LEHMAN

Commissioner of Patents and Trademarks

Attest:

Attesting Officer