

- [54] **APPARATUS AND METHOD FOR READING AND WRITING TEXT CHARACTERS IN A GRAPHICS DISPLAY**
- [75] Inventor: **David J. Bradley, Boca Raton, Fla.**
- [73] Assignee: **International Business Machines Corporation, Armonk, N.Y.**
- [21] Appl. No.: **638,340**
- [22] Filed: **Aug. 6, 1984**

4,225,861 9/1980 Langdon et al. 340/703
 4,283,724 8/1981 Edwards 340/731

Primary Examiner—David L. Trafton
Attorney, Agent, or Firm—Sughrue, Mion, Zinn, Macpeak, and Seas

[57] **ABSTRACT**

Apparatus and method for writing text characters to a raster scan video display operated in an all-points-addressable, or graphics, mode, and for reading characters thus written. A graphic video display buffer directly refreshes the display with graphics data received from a microprogrammed processor. The processor writes a character to the display by selecting and loading into the graphics video display buffer a text character dot pattern retrieved from main storage, and reads a character previously written by comparing a dot pattern retrieved from the display buffer with dot patterns retrieved from main storage. To write a character to the display in color, the graphic dot image of a selected character retrieved from main storage is expanded to a selected pixel and color format, and stored in the graphics video display buffer. Text characters thus written in color are read by retrieving from the display buffer the expanded dot image, restoring the expanded dot image to its original form, and comparing the restored dot image with graphic dot images retrieved from storage.

Related U.S. Patent Documents

Reissue of:

- [64] Patent No.: **4,408,200**
- Issued: **Oct. 4, 1983**
- Appl. No.: **292,084**
- Filed: **Aug. 12, 1981**

- [51] Int. Cl.⁴ **G09G 1/28**
- [52] U.S. Cl. **340/747; 340/703; 340/750**
- [58] Field of Search **340/825.3, 747, 750, 340/703; 382/56**

References Cited

U.S. PATENT DOCUMENTS

- 3,778,810 12/1973 Hayashi 340/747
- 3,906,480 9/1975 Schwartz et al. 340/747 X
- 4,149,145 4/1979 Hartke et al. 340/739

18 Claims, 13 Drawing Figures

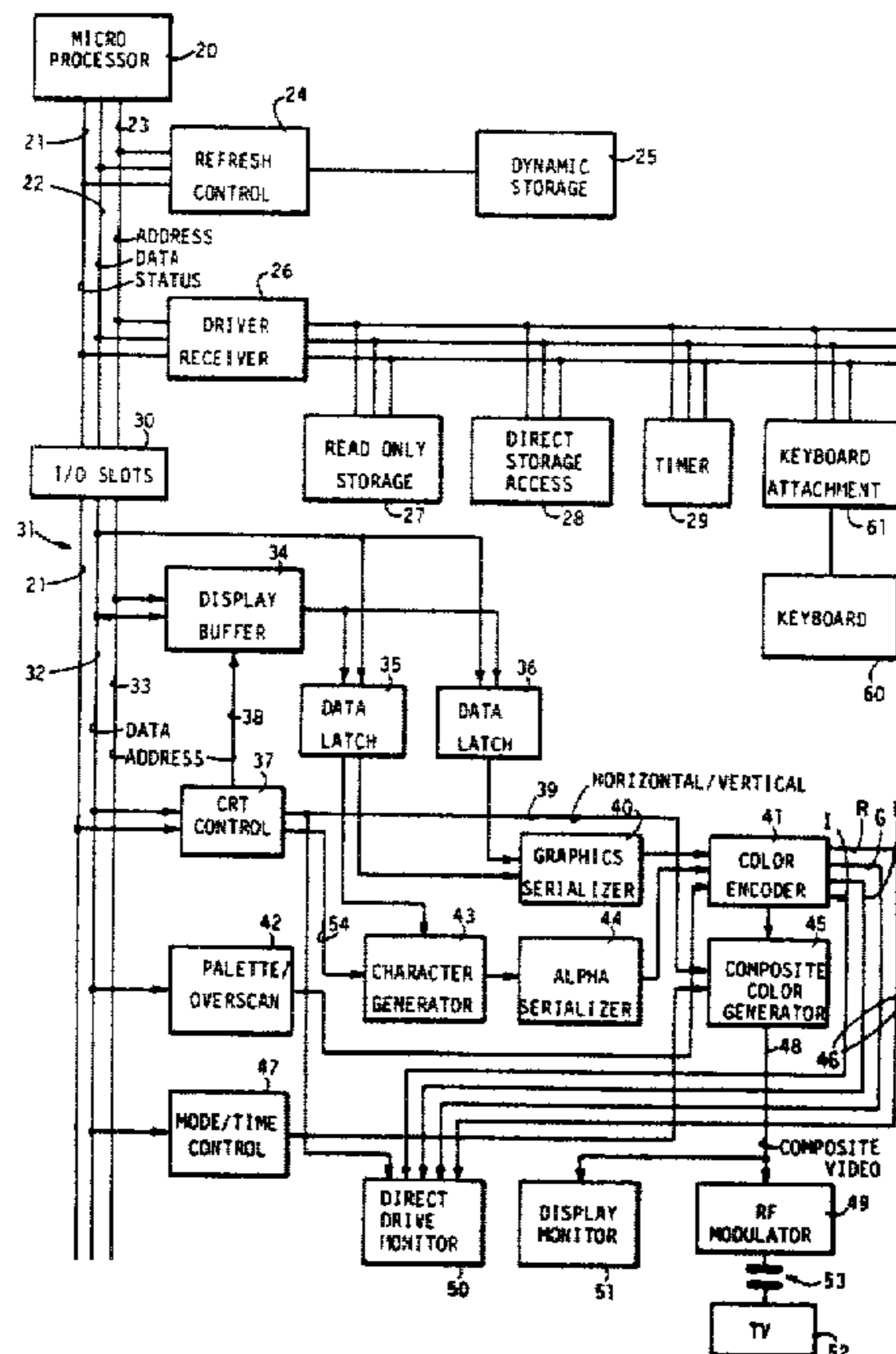

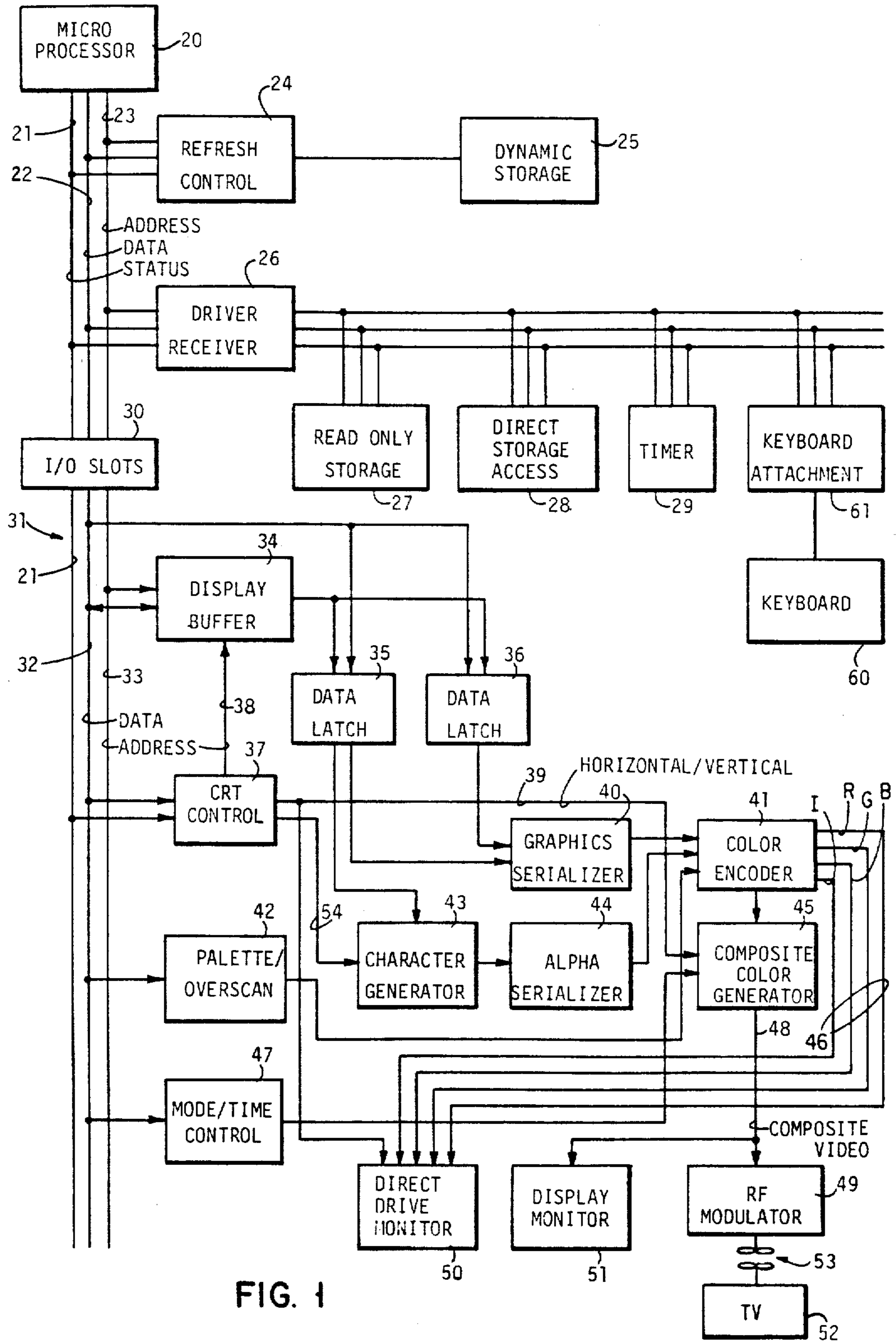

FIG. 1

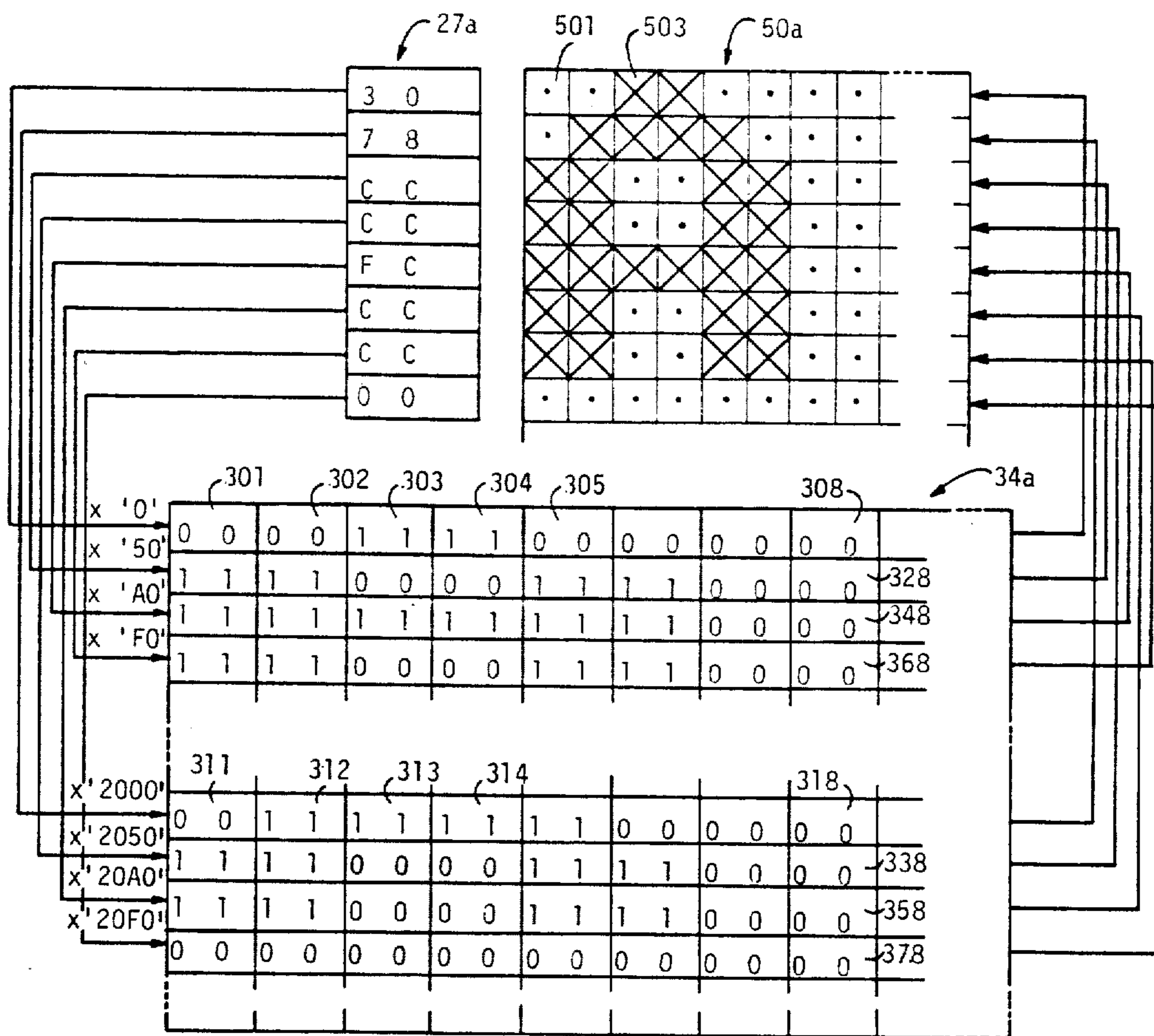

FIG. 2

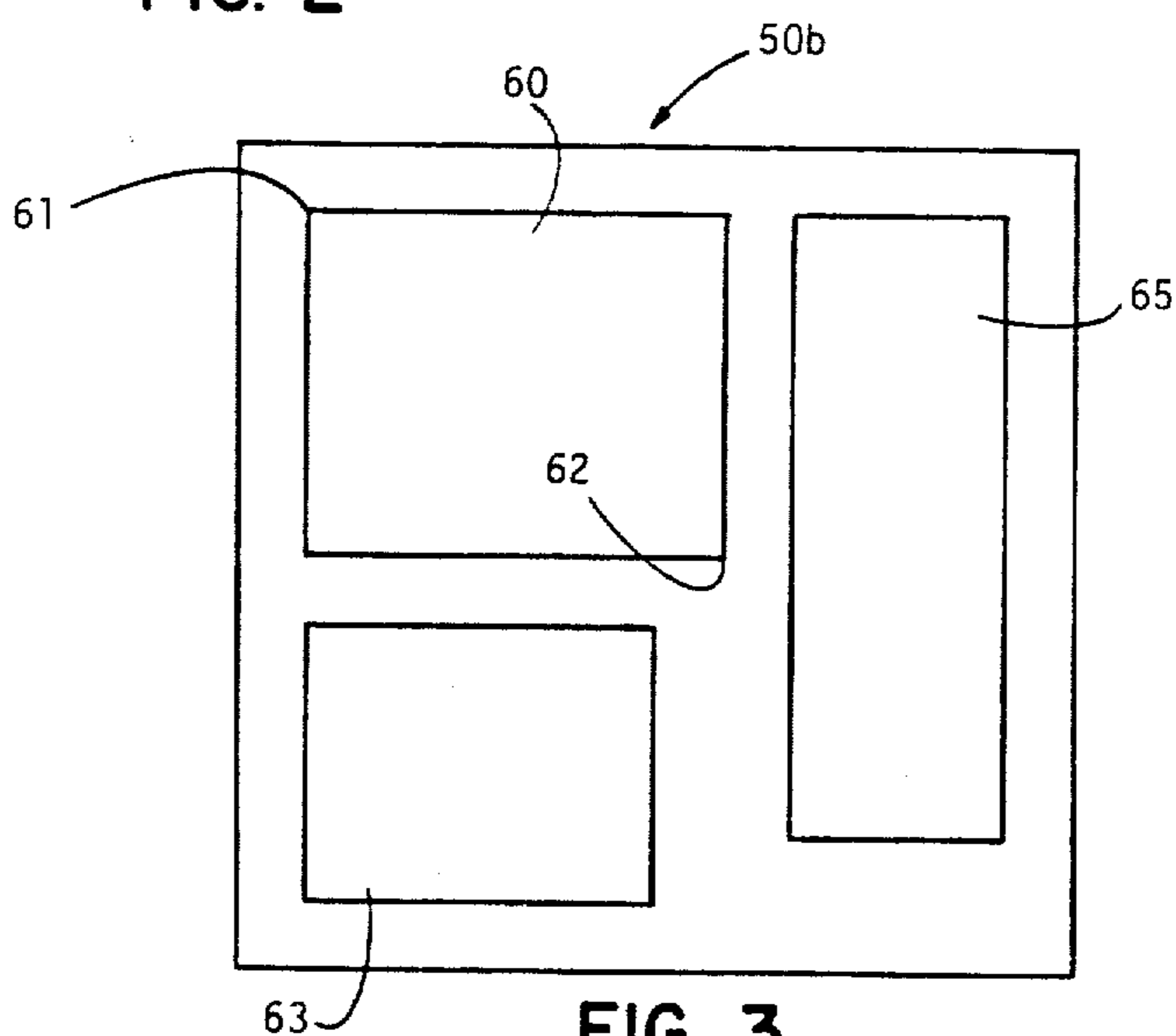

FIG. 3

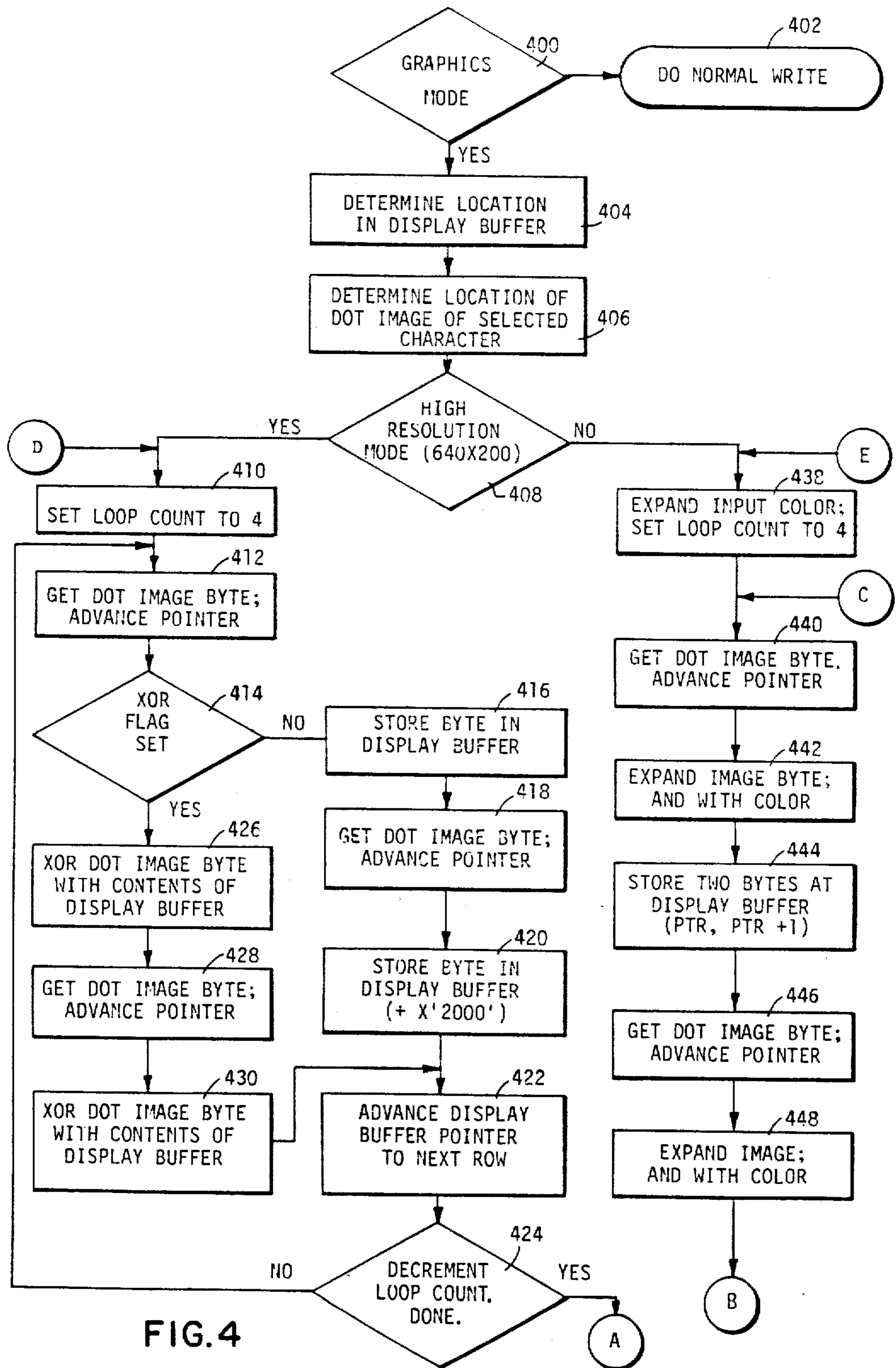

FIG. 4

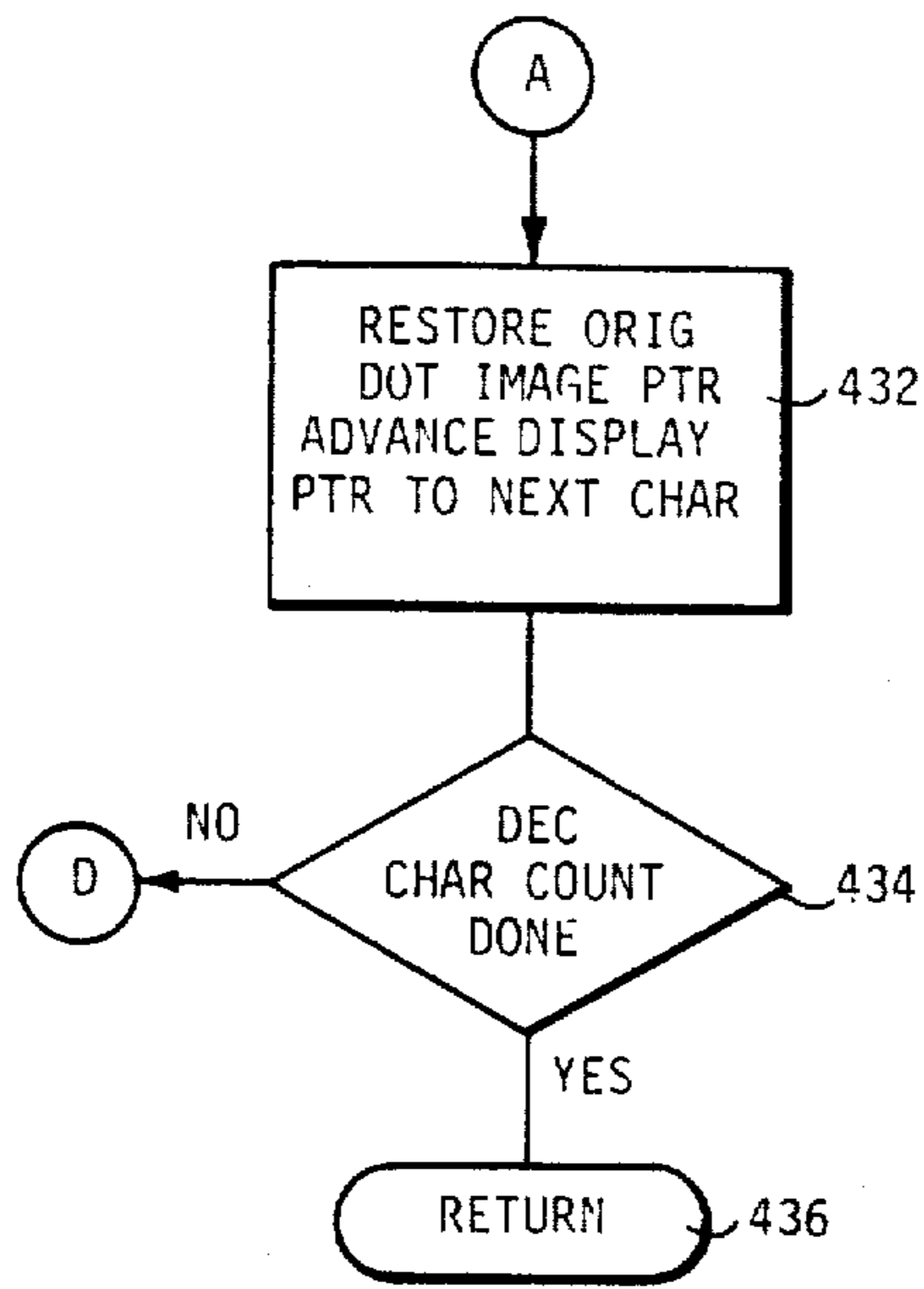

FIG. 5

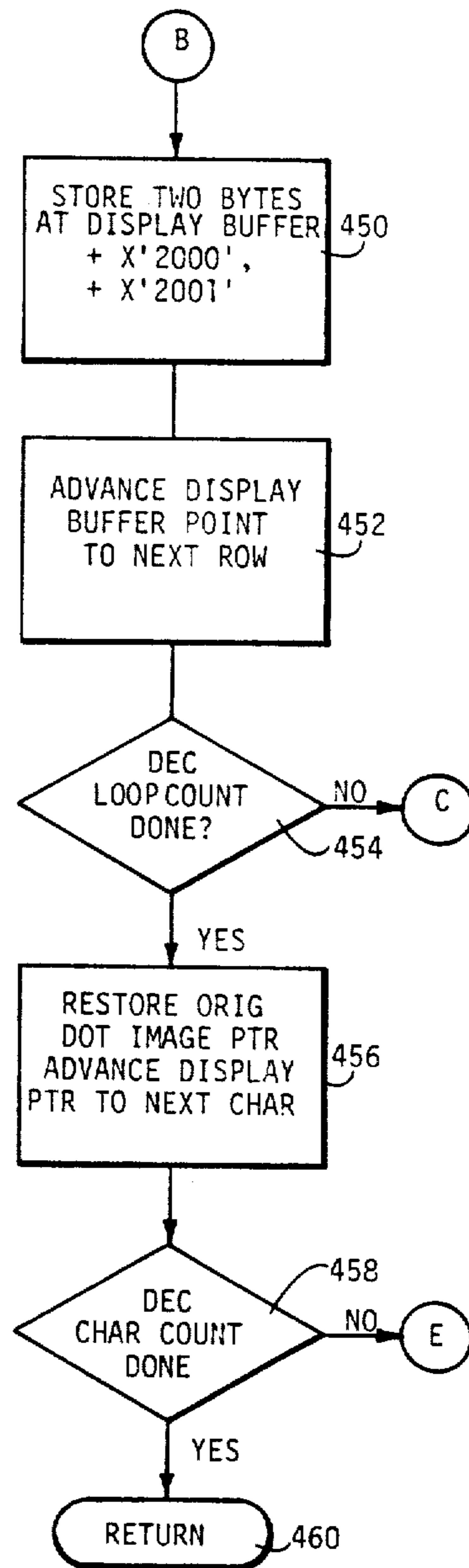

FIG. 6

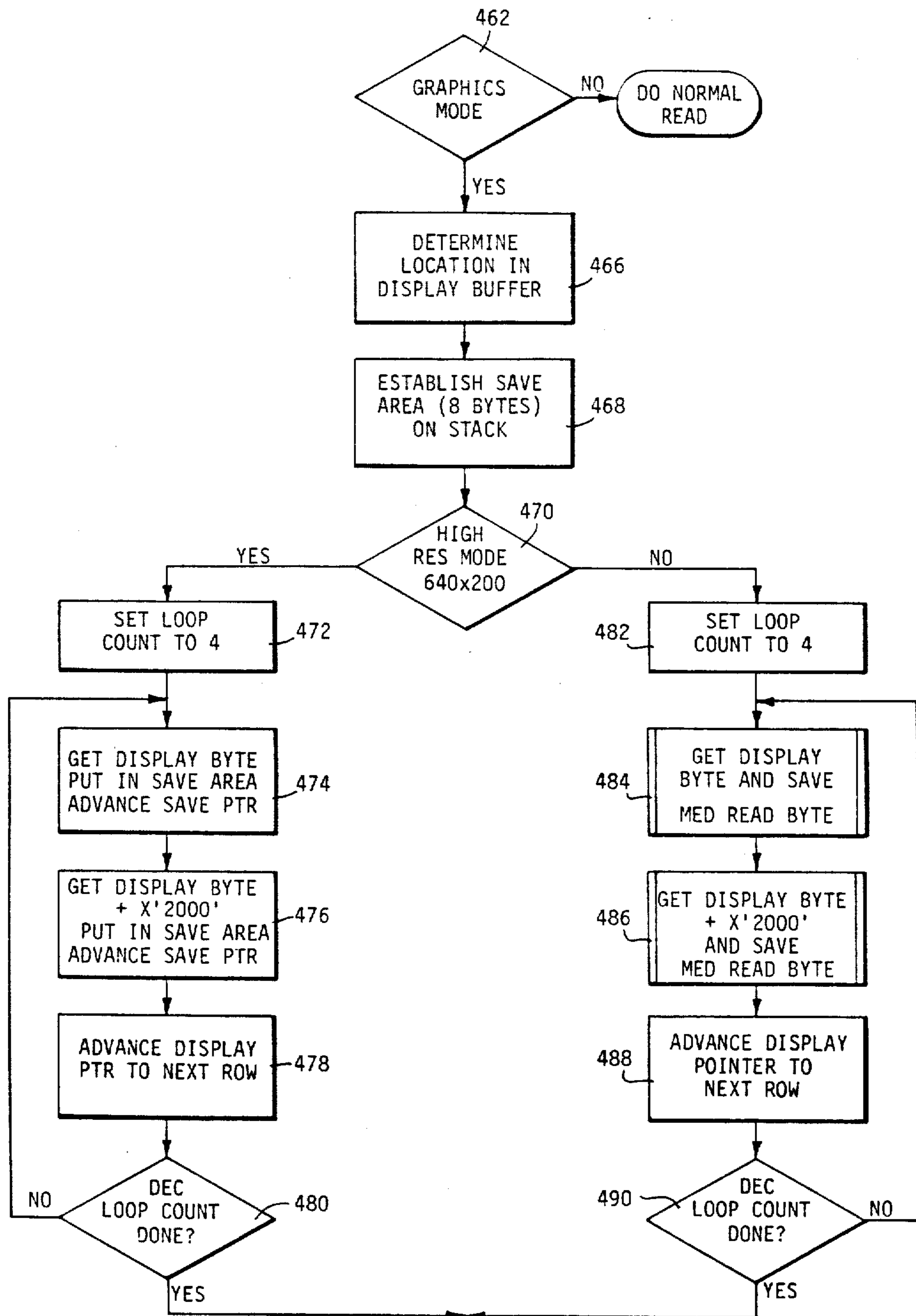

FIG. 7



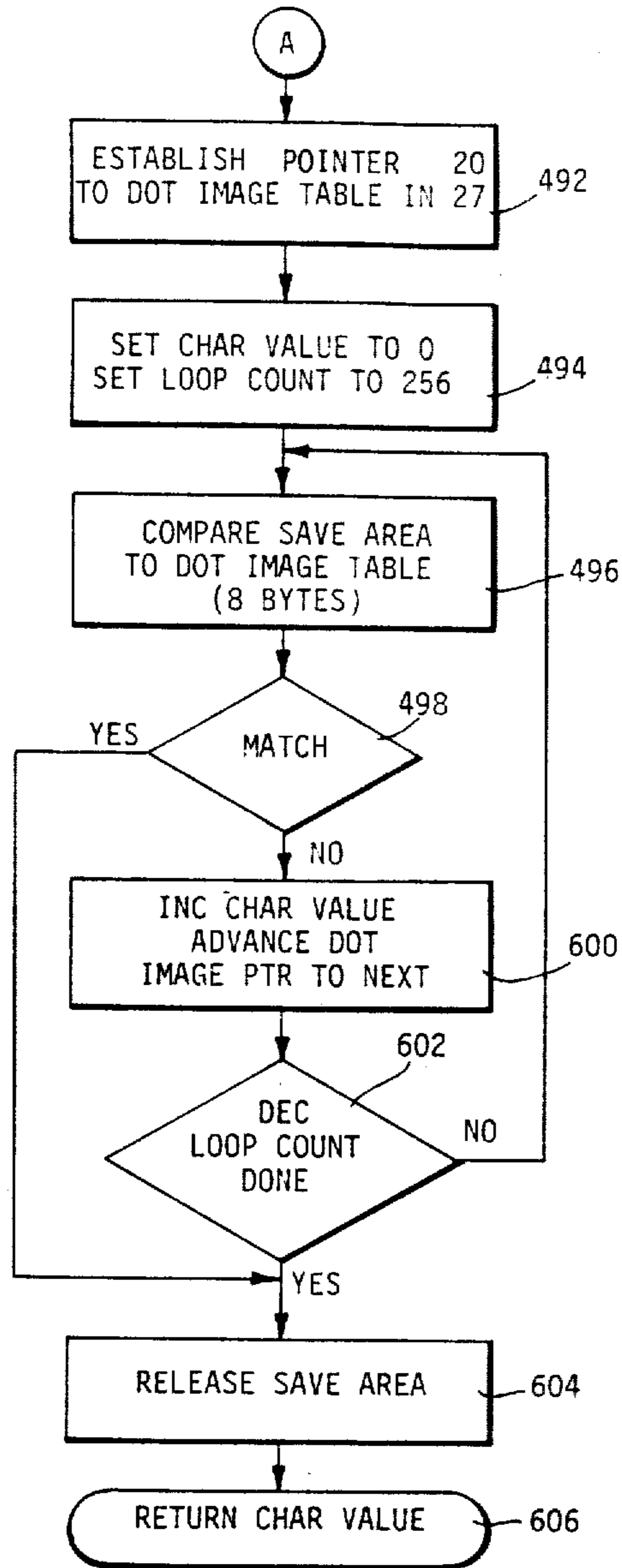

FIG. 8

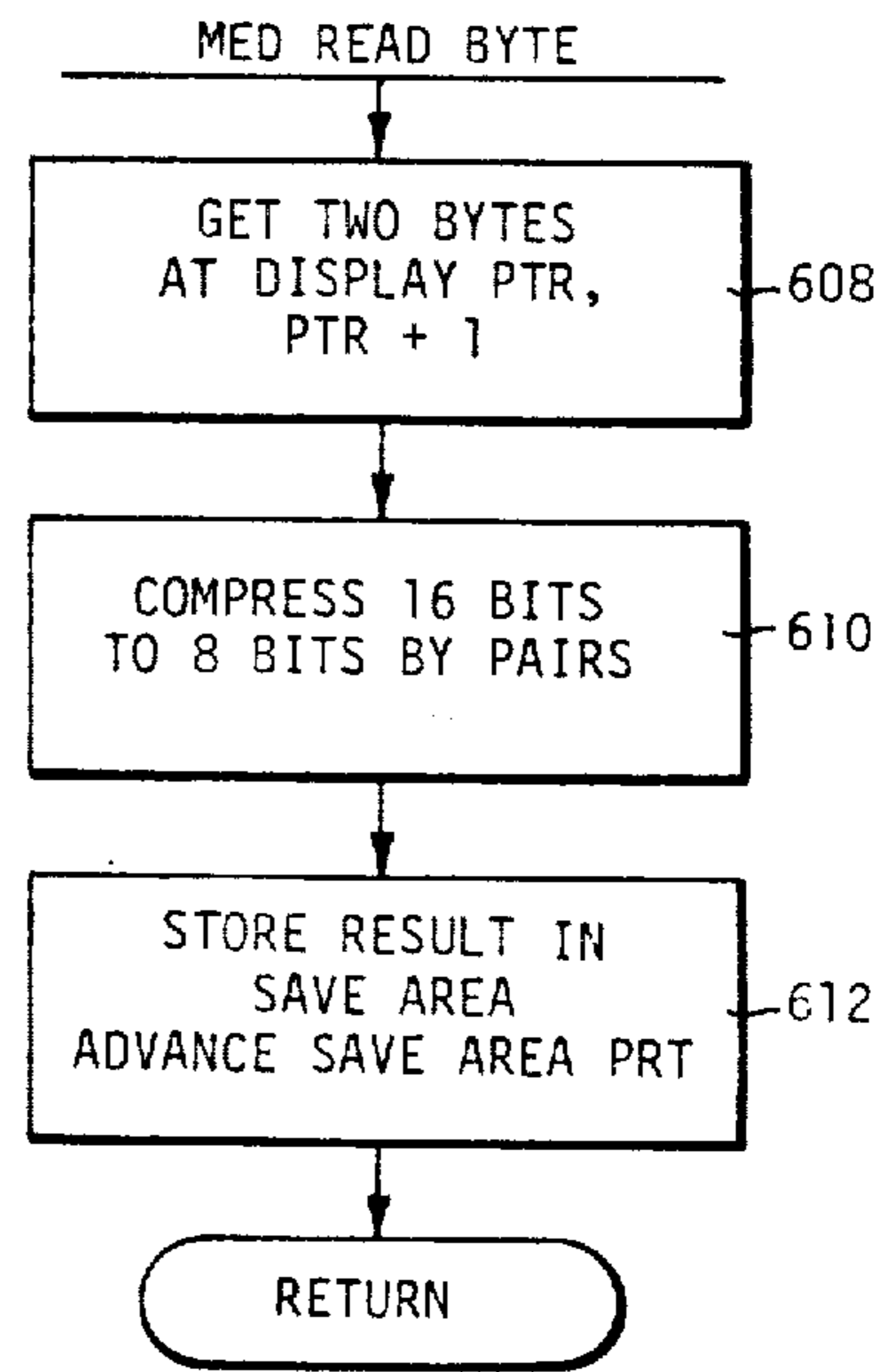

FIG. 9

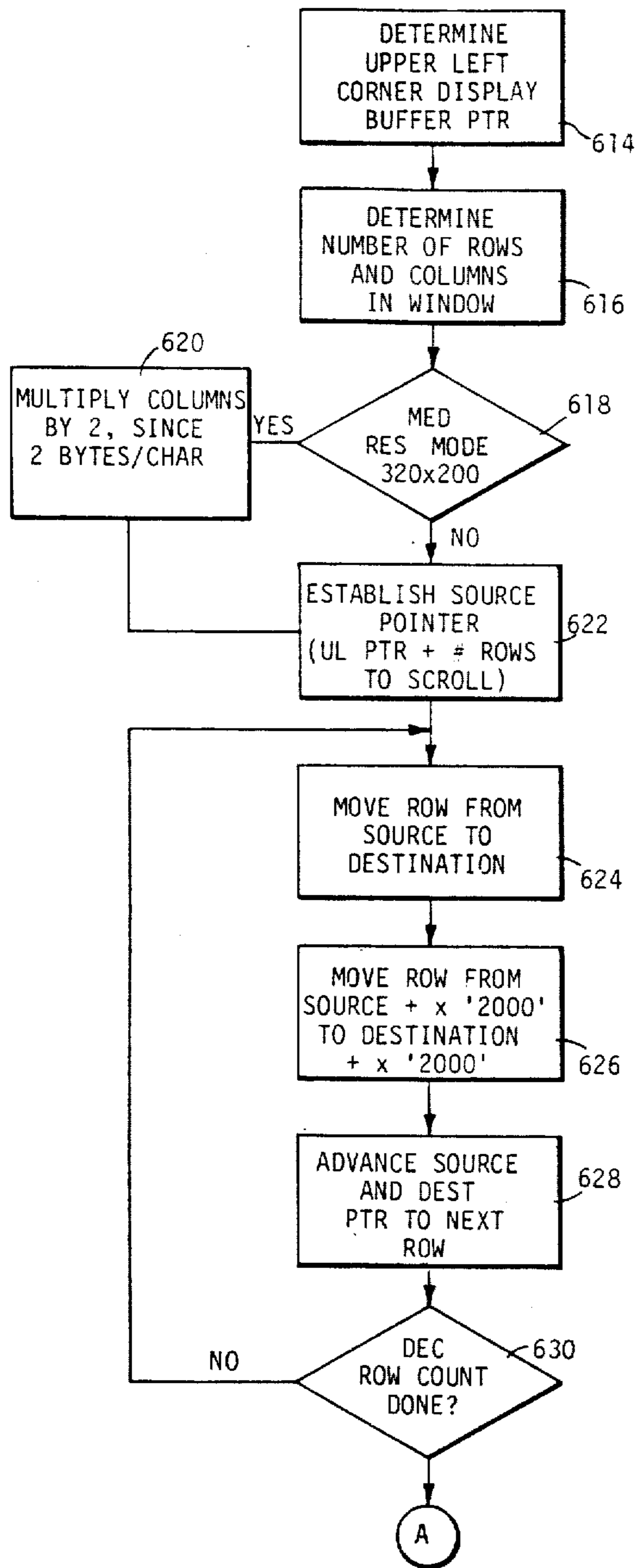

FIG. 10

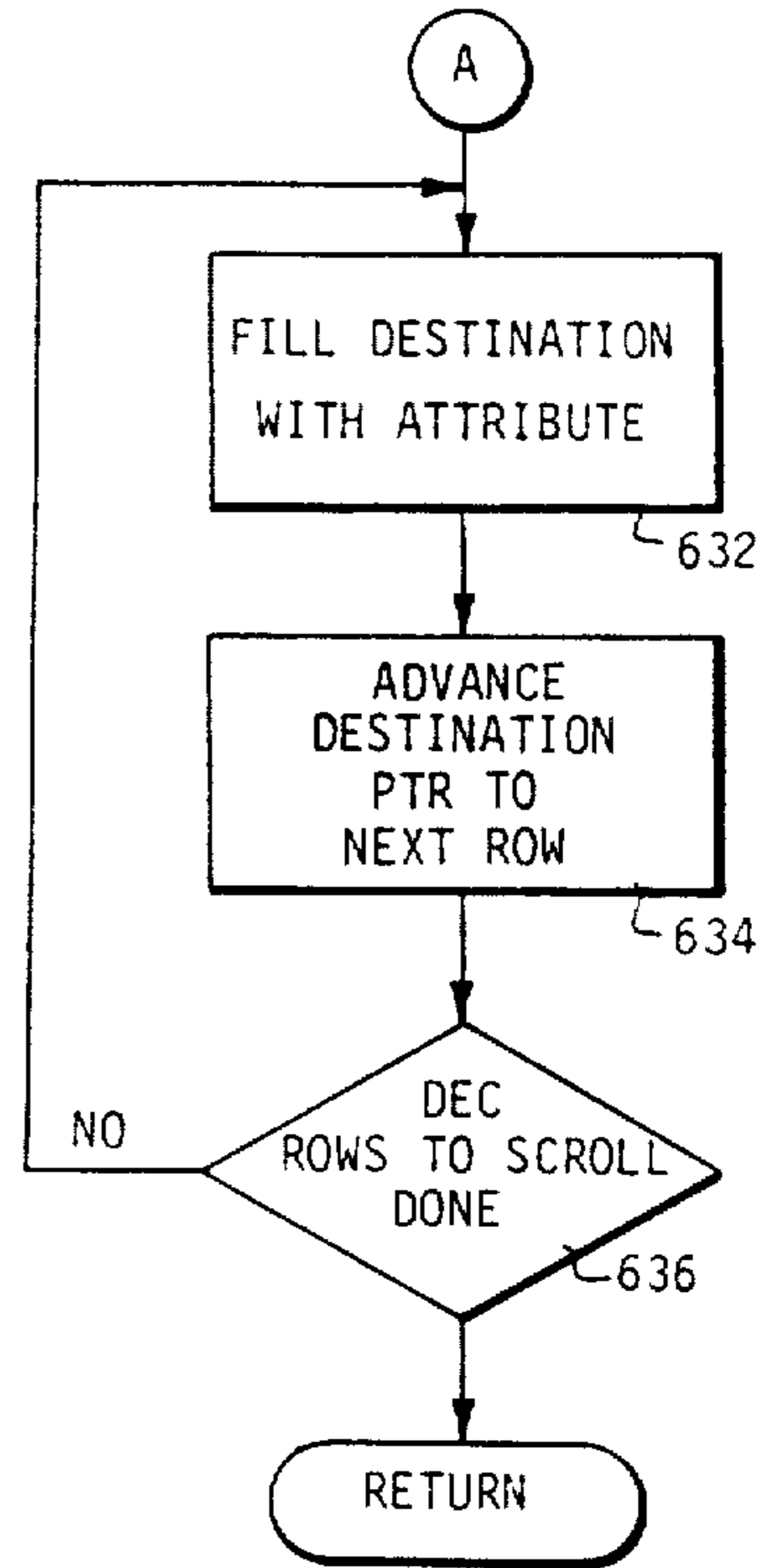

FIG. 11

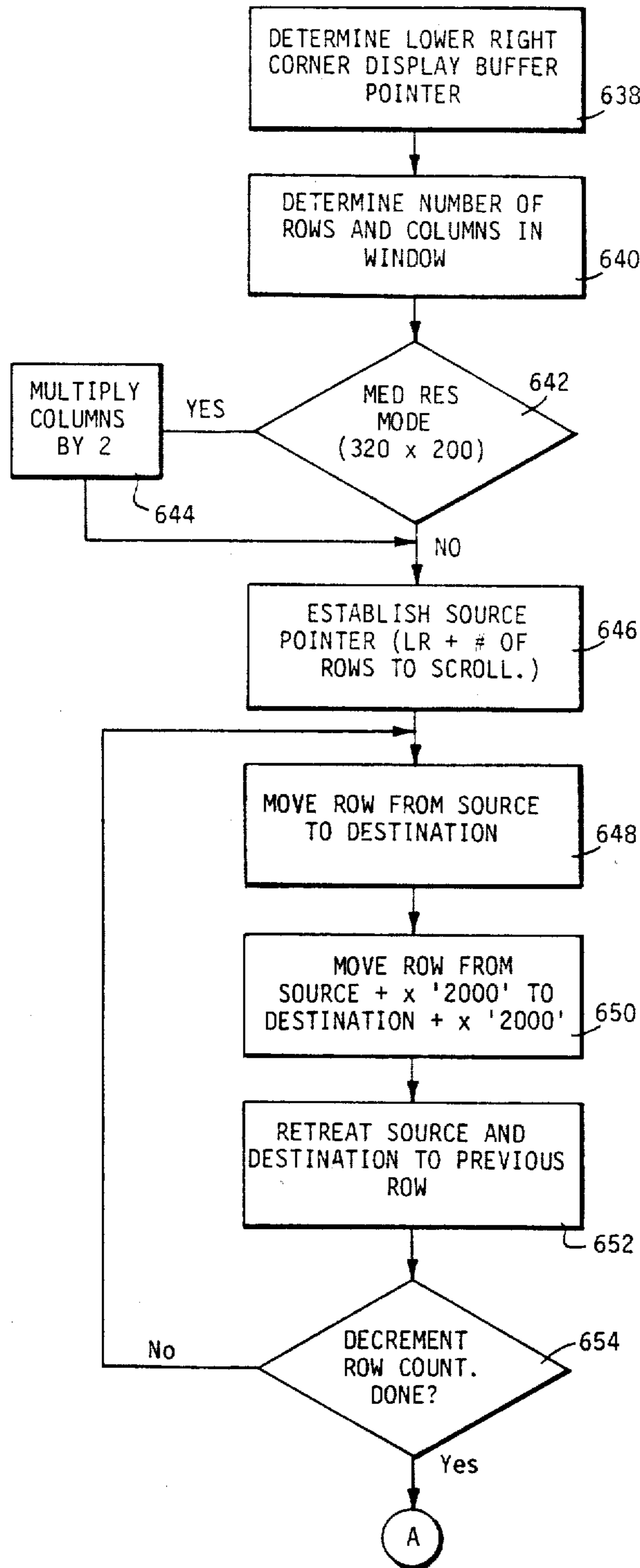

FIG. 12

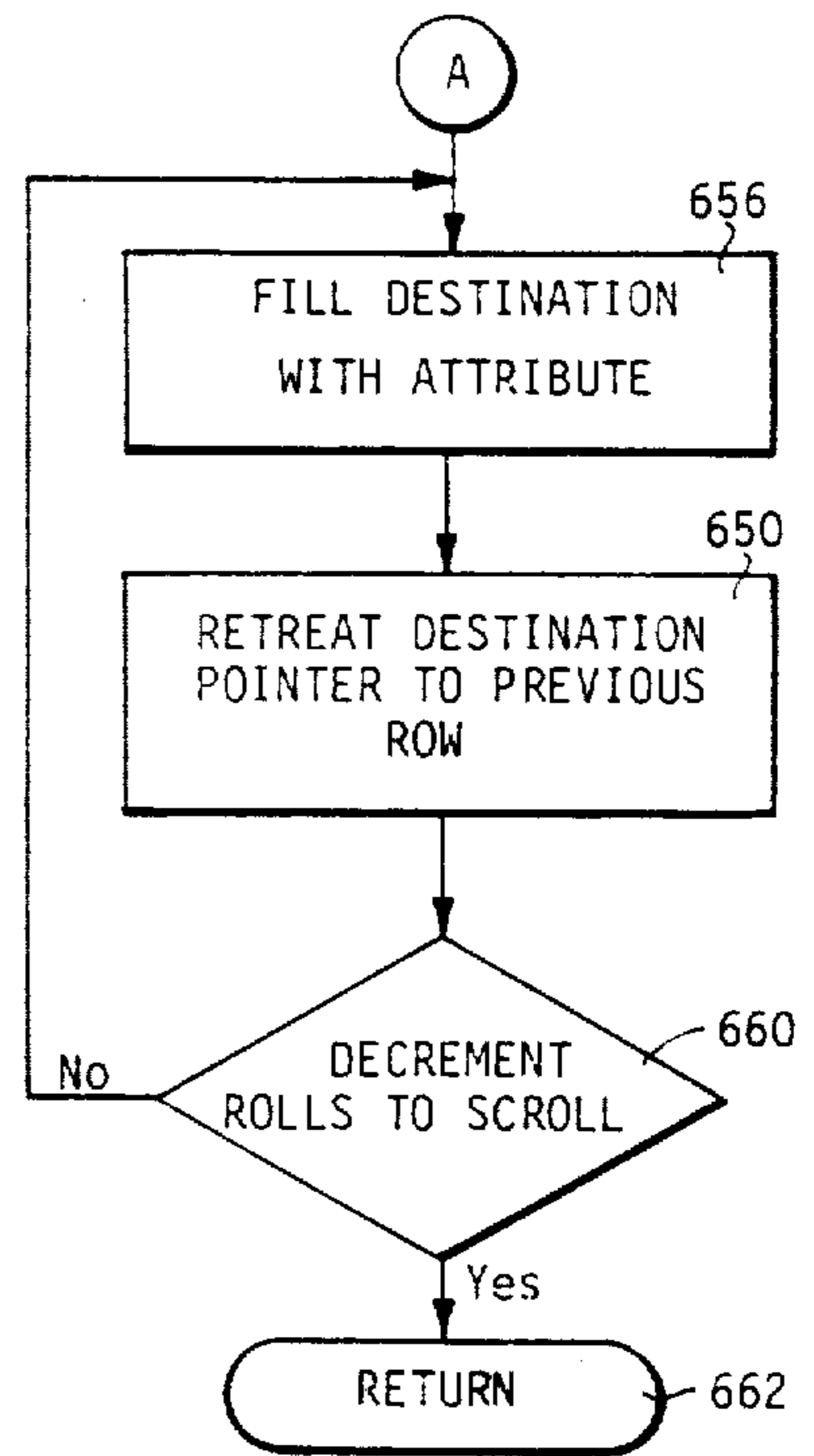

FIG. 13

APPARATUS AND METHOD FOR READING AND WRITING TEXT CHARACTERS IN A GRAPHICS DISPLAY

Matter enclosed in heavy brackets [] appears in the original patent but forms no part of this reissue specification; matter printed in italics indicates the additions made by reissue.

BACKGROUND OF THE INVENTION

1. Field of the Invention

This invention relates to display systems and, more particularly, to a system for reading and writing text characters in a color graphics raster scan, all points addressable video display.

2. Discussion of the Prior Art

A video display typically provides an interface between a data processing machine and a user. Generally, a video image may comprise either strings of characters or of graphics, each of which requires different storage and, heretofore, processing requirements. Because of these differing requirements, many prior art video display systems do not permit the combining of text and graphic data on the same screen. However, many applications of graphic displays would be greatly enhanced by the provision of character data, such as legends on charts or graphs.

U.S. Pat. No. 4,149,145 describes a video display permitting the placement of character data within the region of display of graphic information. This is done by combining both graphic and character data in a video register. Each of the graphic and character data are separately developed, with a character generator providing the character image components and a graphic generator providing the graphic image components. These two components are merged or superimposed to provide a composite video signal. However, in the system of U.S. Pat. No. 4,149,145, there is no provision for reading text characters from the composite signal, and unnecessary complexity is required by the use of separate text character and graphics generators.

SUMMARY OF THE INVENTION

The invention provides apparatus and method for writing text characters to a raster scan video display operated in the graphics mode, and for reading characters thus written.

The apparatus of the invention includes a graphic video display buffer operable in an all points addressable mode for refreshing the display with graphics data, and a processor for loading the graphic data into said graphics video display buffer. The improvement comprises programmable control means referenced by said processor for writing by selecting and loading into said graphics video display buffer a text character dot pattern from main storage, and for reading by comparing dot patterns read from said display buffer with dot patterns in said main storage.

According to the method of the invention, text characters are written to a raster scan, all points addressable video display by retrieving from storage the graphic dot image of a selected character, expanding the graphic dot image to a selected pixel and color format, and storing the expanded dot image in a graphics video display buffer. Text characters are read by retrieving from the display buffer expanded dot images, restoring the expanded dot image to its original form, and com-

paring the restored dot image with graphic dot images selected from storage.

BRIEF DESCRIPTION OF THE DRAWINGS

FIG. 1 is a logic schematic illustrating the video display control apparatus of the invention.

FIG. 2 is a schematic illustration of the relationships between pixel display and storage locations.

FIG. 3 is a schematic illustration of a segmented display screen for use in describing the scrolling features of the invention.

FIGS. 4-6 are logic flow diagrams of the graphics write steps of the method of the invention.

FIGS. 7-9 are logic flow diagrams of the graphics read steps of the invention.

FIGS. 10-11 are logic flow diagrams of the graphics scroll up steps of the invention.

FIGS. 12-13 are logic flow diagrams of the graphics scroll down steps of the invention.

DESCRIPTION OF THE PREFERRED EMBODIMENTS

Referring now to FIG. 1, a description will be given of the apparatus of the invention for reading and writing text characters in a color graphics display.

The display of the invention is particularly suited for use in connection with a microcomputer including microprocessor 20, dynamic storage 25, read only storage 27, display 50, and keyboard 60. In this embodiment, microprocessor 20 may comprise an Intel 8088 CPU, which utilizes the same 16-bit internal architecture as the Intel 8086 CPU but has an external 8-bit data bus 22. For a description of the Intel 8086, and consequently of the 8086 instruction set used in the microprogram assembly language descriptions of the invention set forth hereafter, reference is made to Stephan P. Morse, *The 8086 Primer*, Hayden Book Company Inc., Rochelle Park, N.J., copyright 1980, Library of Congress classification QA76.8.1292M67 001.6'4'04 79-23932 ISBN 0-8104-5165-4, the teachings of which are herein incorporated by reference.

Processor 20 communicates with devices external to its integrated circuit chip via status and control line 21, data bus 22, and address bus 23. Such external devices include dynamic storage 25 (for example, Texas Instruments 4116 RAM) with refresh control 24 (for example, an Intel 8237 DMA driven by an Intel 8253 Timer); and, connected by drivers/receivers 26 (for example, a TTL standard part 74LS245), read only storage 27 (for example, a MOSTEK 36000), direct storage access (or DMA) chip 28 (for example, and Intel 8237 DMA), timer 29 (for example, an Intel 8253 Timer implemented as described in "Refresh Circuit for Dynamic Memory of Data Processor Employing a Direct Memory Access Controller," by James A. Brewer, et al, U.S. patent application Ser. No. 292,075, filed Aug. 12, 1981) and keyboard attachment 66 with keyboard 67.

Input/Output slots 30 provide for the attachment of a further plurality of external devices, one of which, the color graphic display attachment 31 is illustrated. Color graphics display adapter 31 attaches one or more of a wide variety of TV frequency monitor 50, 51 and TV sets 52, with an RF modulator 49 required for attaching a TV via antenna 53. Adapter 31 is capable of operating in black and white or color, and herein provides these video interfaces: a composite video port on line 48, which may be directly attached to display monitor 51 or

to RF modulator 49, and a direct drive port comprising lines 39 and 46.

Herein, display buffer 34 (such as an Intel 2118 RAM) resides in the address space of controller 20 starting at address X'B8000'. It provides in 16K bytes of dynamic RAM storage a raster scan bit map. A dual-ported implementation allows CPU 20 and graphics control unit 37 to access buffer 34.

An APA mode, two resolution modes will be described: APA color 320×200 (320 pixels per row, 200 rows per screen) mode and APA black and white 640×200 mode. In 320×200 mode, each pixel may have one of four colors. The background color (color 00) may be any of the sixteen possible colors. The remaining three colors come from one of two palettes in palette 42 selected by microprocessor 20 under control of read only storage 27 program: one palette containing red (color 01), green (color 10), and yellow (color 11), and the other palette containing cyan (color 01), magenta (color 10), and white (color 11). The 640×200 mode is, in the embodiment described, available only in two colors, such as black and white, since the full 16KB of storage in display buffer 34 is used to define the pixels on or off state.

In A/N mode, characters are formed from ROS character generator 43, which herein may contain dot patterns for 254 characters. These are serialized by alpha serializer 44 into color encoder 41 for output to port lines 46 or via lines 48 to composite color generator 48 for output to composite video line 48.

Display adapter 31 includes a CRT control module 37, which provides the necessary interface to processor 20 to drive a raster scan CRT 50-52. Herein, CRT control module 37 comprises a Motorola MC6845 CRT controller (CRTC) which provides video timing on horizontal/vertical line 39 and refresh display buffer addressing on lines 38. The Motorola MC6845 CRTC is described in MC6845 MOS (N-channel, Silicon-Gate) CRT controller, Motorola Semiconductor's publication ADI-465, copyright Motorola, Inc., 1977.

As shown in FIG. 1, the primary function of CRTC 37 is to generate refresh addresses (MA0-MA13) on line 38, row selects (RA0-RA4) on line 54, video monitor timing (HSYNC, VSYNC) on line 39, and display enable (not shown). Other functions include an internal cursor register which generates a cursor output (not shown) when its content compares to the current refresh address 38. A light-pen strobe input signal (not shown) allows capture of refresh address in an internal light pen register.

All timing in CRTC 37 is derived from a clock input (not shown). Processor 20 communicates with CRTC 37 through buffered 8-bit data bus 32 by reading/writing into an 18-register file of CRTC 37.

The refresh memory 34 address is multiplexed between processor 20 and CRTC 37. Data appears on a secondary bus 32 which is buffered from the processor primary bus 22. A number of approaches are possible for solving contentions for display buffer 34:

- (1) Processor 20 always gets priority.
- (2) Processor 20 gets priority access any time, but can be synchronized by an interrupt to perform accesses only during horizontal and vertical retrace times.
- (3) Synchronize process by memory wait cycles.
- (4) Synchronize processor 20 to character rate.

The secondary data bus concept in no way precludes using the display buffer 34 for other purposes. It looks

like any other RAM to processor 20. For example, using approach 4, a 64K RAM buffer 34 could perform refresh and program storage functions transparently.

CRTC 37 interfaces to processor 20 on bidirectional data bus 32 (DO-D7) using Intel 8088 CS, RS, E, and R/W control lines 21 for control signals.

The bidirectional data lines 32 (DO-D7) allow data transfers between the CRTC 37 internal register file and processor 20.

The enable (E) signal on lines 21 is a high impedance TTL/MOS compatible input which enables the data bus input/output buffers and clocks data to and from CRTC 37. This signal is usually derived from the processor 20 clock.

The chip select (CS) line 21 is a high impedance TTL/MOS compatible input which selects CRTC 37 when low to read or write the CRTC 37 internal register file. This signal should only be active when there is a valid stable address being decoded on bus 33 from processor 20.

The register select (RS) line 21 is a high impedance TTL/MOS compatible input which selects either the address register (RS='0') or one of the data registers (RS='1') of the internal register file of CRTC 37.

The read/write (R/W) line is a high impedance TTL/MOS compatible input which determines whether the internal register file in CRTC 37 gets written or read. A write is active low ('0').

CRTC 37 provides horizontal sync (HS/vertical sync (VS) signals on lines 39, and display enable signals.

Vertical sync is a TTL compatible output providing an active high signal which drives monitor 50 directly or is fed to video processing logic 45 for composite generation. This signal determines the vertical position of the displayed text.

Horizontal sync is a TTL compatible output providing an active high signal which drives monitor 50 directly or is fed to video processing logic 45 for composite generation. This signal determines the horizontal position of the displayed text.

Display enable is a TTL compatible output providing an active high signal which indicates CRTC 37 is providing addressing in the active display area of buffer 34.

CRTC 37 provides memory address 38 (MA0-MA13) to scan display buffer 34. Also provided are raster addresses (RA0-RA4) for the character ROM.

Refresh memory 34 address (MA0-MA13) provides 14 outputs used to refresh the CRT screen 50-52 with pages of data located within a 16K block of refresh memory 34.

Raster addresses 54 (RA0-RA4) provides 5 outputs from the internal raster counter to address the character ROM 43 for the row of a character.

Palette/overscan 42 and mode select 47 are implemented as a general purpose programmable I/O register. Its function in attachment 31 is to provide mode selection and color selection in the medium resolution color graphics mode.

Time control 47 further generates the timing signals used by CRT controller 37 and by dynamic RAM 34. It also resolves the CPU 20 graphic controller 37 contentions for accessing display buffer 34.

An A/N mode, attachment 31 utilizes ROS (for example, a MOSTEK 36000 ROS) character generator 43, which consists of 8K bytes of storage which cannot be read/written under software control. The output of character generator is fed to alpha serializer 44 (such as a standard 74 LS 166 shift register), and thence to color

encoder 41. As elements 43, 44 are included only for completeness, they are not utilized in the invention and will not be further described.

The output of display buffer 34 is alternatively fed for every other display row in a ping pong manner through data latches 35, 36 to graphics serializer 40, and thence to color encoder 41. Data latches 35, 36 may be implemented as standard TTL 74 LS 244 latches, graphics serializer 40 as a standard TTL 74 LS 166 shift register. Color encoder 41 may be implemented in logic such as is described in M. A. Dean, et al, "Composite Video Color Signal Generator From Digital Color Signals", assignees Ser. No. 292,074, 8-1981, of common assignee as the present invention. Composite color generator 45 provides logic for generating composite video 48, which is base band video color information.

The organization of display buffer 34 to support the 200x320 color graphics mode is illustrated in FIG. 2 for generating, by way of example, a capital A in the upper left-hand position 50a of monitor 50. Read only storage 27 stores for each character displayable in graphics mode an eight byte code, shown at 27a as sixteen hexadecimal digits 3078CCCCFCCCCCOO. In FIG. 2, these are organized in pairs, each pair describing one row of an 8x8 matrix on display 50a. In display 50a, an "X" in a pixel location denotes display of the foreground color (herein, code 11) and a "." denotes display of the background color (code 00).

When the character "A" is to be displayed, the sixteen digit hex code from read only storage 27 (or, equivalently, from dynamic storage 25) is, in effect converted to binary. Thus, the first 8 pixel row, 30 hex, becomes 00110000, in binary. This eight bit binary code is then expanded to specify color, with each "0" becoming "00" to represent the background color, and each "1" becoming 10, 01, or 11 to specify one of the three foreground colors from the selected palette. In FIG. 2, each "1" in the binary representation of the character code from storage 27 becomes "11" (which for palette two represents yellow; see below). Thus, the hex 30 representation of the first 8-pixel row of character "A", is expanded to 00 00 11 11 00 00 00 00 in display buffer 34a, shown at location '0' (in hexadecimal notation, denoted as x '0'). Graphics storage 34 is organized in two banks of 8000 bytes each, as illustrated in Table 1, where address x '0000' contains the pixel information (301-304) for the upper left corner of the display area, and address x '2000' contains the pixel information for the first four pixels (311-314) of thesecond row of the display (in this case, the first 8 bit byte of the two byte binary expansion 00 11 11 11 00 00 00 of hex 78).

TABLE 1

DISPLAY BUFFER 34 ADDRESSING		
#0000	[Diagram: A vertical rectangle divided into two horizontal sections]	even scans(0, 2, 4, . . . , 198) (8000 bytes)
#1F3F		
#2000		odd scans(1, 3, 5, . . . , 199) (8000 bytes)
#3F3F		

For the 200x640 mode (black and white), addressing and mapping of display buffer 34 to display 50 is the same as for 200x320 color graphics, but the data format is different: each bit in buffer 34 is mapped to a pixel on screen 50 (with a binary 1 indicating, say, black; and binary 0, white).

Color encoder 41 output lines 46I (intensity), R (red), G (green), B (blue), provide the available colors set forth in Table 2:

TABLE 2

COLOR ENCODER OUTPUT 46				
I	R	G	B	COLOR
0	0	0	0	Black
0	0	0	1	Blue
0	0	1	0	Green
0	0	1	1	Cyan
0	1	0	0	Red
0	1	0	1	Magenta
0	1	1	0	Brown
0	1	1	1	Light Gray
1	0	0	0	Dark Gray
1	0	0	1	Light Blue
1	0	1	0	Light Green
1	0	1	1	Light Cyan
1	1	0	0	Light Red
1	1	0	1	Light Magenta
1	1	1	0	Yellow
1	1	1	1	White

Referring now to FIGS. 4-9, in connection with the Intel 8086 assembly language (ASM-86) listings embedded in microcode in read only storage 27, executed in microprocessor 20 to control the operation of video attachment 31, and set forth in Tables 3 through 12, a description will be given of the method of the invention for writing text characters to a video screen operating in APA, or graphics mode. The Intel 8086 architecture and ASM-86 language is explained in Morse, The 8088 Primer, supra.

In Table 3 is set forth the preamble and various initialization procedures to the Graphics Read/Write Character microprogram in ROS 27. While the control program, in this embodiment, is shown stored in a read only store 27, it is apparent that such could be stored in a dynamic storage, such as storage 25.

In step 400, a data location in RAM 25 is tested to determine if the system is graphics write mode. If not, and a character is to be written, a branch to normal A/N character mode 402 is taken and the method of the invention bypassed.

Table 4 sets forth the 8086 assembly language listing for the graphics write steps, Table 5 the high resolution (black and white, or 640x200) mode thereof, and Table 6 the medium resolution (color, or 320x200) mode.

In step 404, lines 53-57 of Table 4, addressability to the display buffer is established: the location in display buffer (REGEN) 34 to receive the write character is determined and loaded into register DI of processor 20. In step 406, lines 58-83, addressability to the stored dot image is established: the location in read only storage (ROM) 27 or dynamic storage (USER RAM) 25 of the dot image of the character to be displayed is determined. After execution of Table 4, line 92, processor 20 registers DS, SI are pointing at the location in ROM 27 or RAM 25 where the character dot image is stored, and DS, SI define addressability of the dot image. At step 408, line 93 the test is made for high resolution (640x200) or medium resolution (320x200) mode, (JC means jump on carry, and is an old Intel 8080 operation code which is the same as JB/JNAE in ASM-86, which works, amazingly enough, even though JC is not a documented operation code in ASM-86.) In high resolution mode, control passes to step 410, line 95 (Table 5). For medium resolution mode, it passes to step 438, line 124 (Table 6).

For high resolution mode (640×200, black and white), the procedure of steps 412-424 (426-430 included, if pertinent) is performed for each of the four bytes required to provide the dot image for a character in graphics mode. Step 410 (line 99) sets the loop counter register DH to four, and in steps 412 (step 101) a dot image byte from ROM 27 or RAM 25 pointed to by processor 20 registers DS, SI is loaded into the processor 20 string. The LODSB and STOSB instructions at lines 101, 120 and 104, 119, etc. perform the following actions:

```
LODSB: MOV AL, [DS:SI]; SI←SI+1
```

```
STOSB: MOV [ES:DI], AL; DI←DI+1
```

At step 414 (line 102) a test is made to determine whether or not the application requesting the display of the character wants the character to replace the current display, or to be exclusive OR'd with the current display. In steps 416-422, (lines 104-115) the current display is replaced by storing this and the next dot image bytes in display buffer 34, with the next byte offset or displaced by X'2000' from the location of this byte in buffer 34. In steps 426-430 (lines 117-122), the alternative operation of exclusive ORing those two bytes into display buffer 34 is performed. If more than one identical character is to be written to display screen 50 in this operation, steps 432-434 of FIG. 5 (lines 112-114) condition the procedure for executing steps 410 through 434 for each such character.

Table 6 sets forth the 8086 assembly language listing in ROM 27 executed by processor 20 to control display attachment 31 to display a text character in the medium resolution (320×200) mode, and corresponds to steps 438 (FIG. 4) to 460 (FIG. 6).

In steps 438 (lines 128, Table 6, and Table 8) the input color (two bits, 01, 10 or 11) is expanded to fill a 16-bit word by repeating the two bit code. In step 440 (line 134), a byte of character code points are loaded into the AL register of processor 20 from storage 25, 27. In step 442, (line 135) each bit in the 1 byte AL register (character code points) is doubled up by calling EXPAND BYTE, Table 9; and the result is AND'd to the expanded input color (at line 136).

In step 444 (lines 142-143) the resulting word (2 bytes) of step 442 is stored in display buffer 34. This is shown, by way of example, at location X'O' in FIG. 2, the stored word comprising fields 301-308. (In FIG. 4, the XOR procedures of Table 6, lines 137-140 and 147-150 are not shown, but are analogous to the XOR procedure of steps 414-430 for the high resolution mode.)

In step 446 (line 144) the next dot image byte is retrieved from storage 25, 27, and at step 448 it is expanded (line 145) and AND'd with color (line 146). In step 450 (lines 152-153) the resulting word is stored in display buffer 34, offset from the word stored at step 444 by x '2000'.

At step 452 (line 154) the display buffer pointer is advanced to the next row of the character to be displayed, and processing returns (step 454, line 156) to complete the character or proceeds (step 456, 458, 460, lines 156-160) to repeat the completed character as many times as required.

Referring now to logic flow diagrams 7-9 in connection with the 8086 assembly language listings of Tables 10-12, an explanation will be given of the graphic read steps of the invention. In this process, a selected charac-

ter dot image from display buffer 34 is compared against dot image code points retrieved from storage 25, 27, a match indicating that the character in buffer 34 has been identified, or read.

In step 462 it is first determined if video attachment 31 is being operated in the graphics mode. If not, in step 464 the read operation is performed in character mode, and the method of the invention is not involved.

In step 466 (line 171) the location in display buffer 34 to be read is determined by calling procedure POSITION, as set forth in Table 7. In step 468 (line 173) an 8-byte save area is established on a stack within the address space of processor 20.

In step 470 (lines 176-181) the read mode is determined. Control passes to step 482 (Table 11) for medium resolution (color, or 320×200) mode. For high resolution (black/white, or 640×200 mode, at step 472, line 187) the loop count is set to 4 (there being 4 two-byte words per character), and in steps 474-480 (lines 189-197) eight bytes are retrieved from display buffer 34 and put into the save area reserved on the stack in step 468. For medium resolution mode, at step 482 (line 203), the loop count is set equal to 4, and in steps 484-490 (lines 204-210) the character to be read is retrieved from display buffer 34. The procedure MED READ BYTE called at lines 205, 207 is set forth in Table 12 in connection with FIG. 9.

Referring to FIG. 8, at step 492 (Table 11, line 214) processing continues to compare the character, either high or medium resolution mode, read from display buffer 34 with character code points read from storage 25, 27. In step 492 (line 214) the pointer to the dot image table in ROM 27 is established. (The processing of lines 238-250 is executed if the character is not found in ROM 27 and the search must be extended into dynamic storage 25 where the user supplied second half of the graphic character points table is stored.)

In step 494 (lines 220-224) the character value is initialized to zero (it will be set equal to 1 when a match is found), and the loop count set equal to 256 (line 224 sets DX=128, and this is again, at line 249, reestablished for a total of 256 passes through the loop of steps 496-602, if required).

In step 496 (line 229), the character read from display buffer 34 into the save area is compared with the dot image read from storage 25, 27, and the match tested at step 498 (line 232). Loop control steps 600, 602 (lines 233-236) are executed until a match is found, or until all 256 dot images in storage 25, 27 have been compared with a match. In step 604 (line 255) the save area is released, and in step 606 (line 256) the procedure ends. If a character match has occurred in step 498, the character thus read is located in storage 25, 27 at the location pointed to by register AL. AL=0 if the character was not found (a not unexpected result if a character had been exclusively OR'd into the display buffer 24 at the location being read, such as at steps 426-450).

Referring now to FIG. 9 in connection with Table 12, the procedure MED READ BYTE, called at steps 484 and 486, will be described. This procedure compresses 16 bits previously expanded from eight to encode the color (see step 442) and stored in display buffer 34 (at step 444) back to the original dot image (obtained previously from storage 25, 27 at step 440). Step 608 (lines 330-331) gets two eight-bit bytes, which in step 610 (lines 332-343) is compressed two bits at a time to recover the original dot image. In step 612 (lines 344-346)

the results are saved in the area pointed to by register BP.

Referring now to FIG. 3, in connection with FIGS. 10-13 and Table 13, a description will be given of the graphic scrolling facility provided for separate discrete areas 60, 63, 65 of display screen 506. This invention is described and claimed in U.S. patent application Ser. No. 6/292,081, filed Aug. 12, 1981 for "Apparatus and Method for Scrolling Text Characters and Graphic Data in Selected Portions of a Graphic Display", by David J. Bradley. In accordance with this invention, a user may define a plurality of windows on the screen in which graphic information blocks may be scrolled. The designation of a scroll section or window 60 requires address of opposite corners, such as the address of the upper left corner 61 and the lower right corner 62, and the number of lines to scroll. The difference in corner addresses sets the window. The color of the newly blanked line is established by a blanking attribute. Within these parameters, the graphic scrolling procedure of FIGS. 10-13 is performed. By this approach, both text (graphic) and display may be scrolled within separate windows 60, 63, and 65.

In Table 13, certain 8086 assembly language parameters are initialized. (Reference to graphics R/W dot does not pertain to the present invention.)

In Tables 14 and 15, the scroll up assembly language statements corresponding to FIGS. 10 and 11 are set forth. (The line numbers of Tables 13-19 overlap those of previous tables, but the step numbers of the figures do not.)

In step 614 (line 161) the pointer to the display buffer 34 location corresponding to upper left corner 61 of the display window 60 to be scrolled is placed in processor 20 register AX. In step 616 (lines 169-174) is determined the number of rows and columns in window 60. In step 618 (lines 178-179) the mode is determined, and if 320x200 mode is detected, in step 620 (lines 182-183) the number of columns in the window is adjusted to handle two bytes per character.

In step 622 (lines 185-200 of Table 15), the source

pointer is established equal to upper left (UL) pointer plus the number of rows (from register AL) to scroll, the result placed in register SI.

In steps 624, 626 (line 203) a call is made to procedure ROW MOVE (Table 18) to move a row from source (pointed to by SI) to destination (pointed to by DI). Line 314 performs the move of step 624, line 322 of step 626, and lines 317-318 adjust the pointers (note line 17, Table 13—ODD FLD is equal to X'2000').

In step 628 (lines 204-205), the source (SI) and destination (DI) pointers are advanced to the next row of the screen window. In step 630 (lines 206-207) the row count is decremented and, if the process is not complete, the procedure of steps 624-630 repeated.

In step 632 (FIG. 11; line 213) procedure ROW CLEAR (Table 19) is called to clear a row by filling it with the fill value for blanked lines specified in processor 20 register BH and transferred to the AL register at line 211. The REP STOSB instruction at lines 333, 338 stores the byte contained in AL into the byte whose offset is contained in DI, increments DI, and repeats to fill every byte of the row with the blanking attribute (which may be the screen background color, for example.)

In step 634 (line 214) destination pointer DI is advanced to the next row, and in step 636 (lines 215, 216) the number BL of rows to scroll is decremented, and the loop of steps 632-636 executed for each row to be scrolled.

The procedure for scroll down is set forth in FIGS. 12 and 13, in connection with the 8086 assembly language source code instructions of Tables 16-19. The procedure is analogous to that for scroll up, wherever step 638 corresponds to lines 239-242, step 640 to lines 250-256, step 642 to lines 257-261, step 644 to lines 263-265, step 646 to lines 267-283, steps 648 and 650 to line 286, step 652 to lines 287-288, step 654 to lines 289-290, step 656 to line 296, step 658 to line 297, step 660 to lines 298, 299 and step 662 to line 301.

The assembly language code listings of Tables 3 through 19 are Copyrighted by IBM Corporation, 1981, and are reproduced herein by consent of IBM.

TABLE 3: GRAPHICS READ/WRITE CHARACTER INITIALIZATION

LINE	SOURCE
1	%TITLE('VIDEO4 GRAPHICS READ/WRITE CHARACTER')
2	%PAGELENGTH(43)
3	-----
4	; GRAPHICS WRITE
5	; THIS ROUTINE WRITES THE ASCII CHARACTER TO THE CURRENT
6	; POSITION ON THE SCREEN.
7	; ENTRY --
8	; AL = CHARACTER TO WRITE
9	; BL = COLOR ATTRIBUTE TO BE USED FOR FOREGROUND COLOR
10	; IF BIT 7 IS SET, THE CHAR IS XOR'D INTO THE REGEN BUFFER
11	; (0 IS USED FOR THE BACKGROUND COLOR)
12	; CX = NUMBER OF CHARS TO WRITE
13	; DS = DATA SEGMENT
14	; ES = REGEN SEGMENT
15	; EXIT --
16	; NOTHING IS RETURNED
17	;
18	; GRAPHICS READ
19	; THIS ROUTINE READS THE ASCII CHARACTER AT THE CURRENT CURSOR
20	; POSITION ON THE SCREEN BY MATCHING THE DOTS ON THE SCREEN TO THE

```

21 | CHARACTER GENERATOR CODE POINTS
22 | ENTRY —
23 | NONE ( 0 IS ASSUMED AS THE BACKGROUND COLOR
24 | EXIT —
25 | AL = CHARACTER READ AT THAT POSITION (0 RETURNED IF NONE FOUND)
26 |
27 | FOR BOTH ROUTINES, THE IMAGES USED TO FORM CHARS ARE CONTAINED IN ROM
28 | FOR THE 1ST 128 CHARS. TO ACCESS CHARS IN THE SECOND HALF, THE USER
29 | MUST INITIALIZE THE VECTOR AT INTERRUPT 1FH (LOCATION 0007CH) TO
30 | POINT TO THE USER SUPPLIED TABLE OF GRAPHIC IMAGES (8X8 BOXES).
31 | FAILURE TO DO SO WILL CAUSE IN STRANGE RESULTS
32 |-----

```

```

33
34 DUMMY SEGMENT AT 0
35     ORG     01FH*4      | LOCATION OF POINTER
36 EXT_PTR LABEL  DWORD   | POINTER TO EXTENSION
37 DUMMY ENDS
38
39 DATA SEGMENT BYTE PUBLIC
40     EXTRN  CRT_COLS:WORD,CRT_MODE:BYTE,CURSOR_POSN:WORD
41 DATA ENDS
42
43 CODE SEGMENT BYTE PUBLIC
44     ASSUME CS:CODE,DS:DATA,ES:DATA
45     EXTRN  CRT_CHAR_GEN:BYTE
46     EXTRN  VIDEO_RETURN:NEAR
47     PUBLIC GRAPHICS_WRITE
48

```

TABLE 4: GRAPHICS WRITE CHARACTER

```

49 GRAPHICS_WRITE PROC NEAR
50     MOV     AH,0        | ZERO TO HIGH OF CODE POINT
51     PUSH   AX          | SAVE CODE POINT VALUE
52
53 |----- DETERMINE POSITION IN REGEN BUFFER TO PUT CODE POINTS
54
55     CALL   POSITION     | FIND LOCATION IN REGEN BUFFER
56     MOV   DI,AX       | REGEN POINTER IN DI
57
58 |----- DETERMINE REGION TO GET CODE POINTS FROM
59
60     POP    AX          | RECOVER CODE POINT
61     CMP   AL,80H      | IS IT IN SECOND HALF
62     JAE   EXTEND_CHAR | YES
63
64 |----- IMAGE IS IN FIRST HALF, CONTAINED IN ROM
65
66     MOV   SI,OFFSET CRT_CHAR_GEN | OFFSET OF IMAGES
67     PUSH CS           | SAVE SEGMENT ON STACK
68     JMP  SHORT DETERMINE_MODE
69
70 |----- IMAGE IS IN SECOND HALF, IN USER RAM
71
72 EXTEND_CHAR:
73     SUB   AL,80H      | ZERO ORIGIN FOR SECOND HALF
74     PUSH DS          | SAVE DATA POINTER
75     SUB   SI,SI
76     MOV  DS,SI       | ESTABLISH VECTOR ADDRESSING

```

13

```

77     ASSUME DS:DUMMY
78     LDS     SI,EXT_PTR           ; GET THE OFFSET OF THE TABLE
79     MOV     DX,DS               ; GET THE SEGMENT OF THE TABLE
80     ASSUME DS:DATA
81     POP     DS                   ; RECOVER DATA SEGMENT
82     PUSH    DX                   ; SAVE TABLE SEGMENT ON STACK
83
84     |----- DETERMINE GRAPHICS MODE IN OPERATION
85
86     DETERMINE_MODE:
87         SAL     AX,1             ; MULTIPLY CODE POINT
88         SAL     AX,1             ; VALUE BY 8
89         SAL     AX,1
90         ADD     SI,AX             ; SI HAS OFFSET OF DESIRED CODES
91         CMP     CRT_MODE,6
92         POP     DS               ; RECOVER TABLE POINTER SEGMENT
93         JC      MED_RES_WRITE    ; TEST FOR MEDIUM RESOLUTION MODE
94

```

TABLE 5: GRAPHICS WRITE CHARACTER 640x200 BLACK/WHITE MODE

```

95     |----- HIGH RESOLUTION MODE
96     HIGH_CHAR:
97         PUSH    DI               ; SAVE REGEN POINTER
98         PUSH    SI               ; SAVE CODE POINTER
99         MOV     DH,4             ; NUMBER OF TIMES THROUGH LOOP
100    L10:
101         LODSB                    ; GET BYTE FROM CODE POINTS
102         TEST    BL,B0H           ; SHOULD WE USE THE FUNCTION
103         JNZ     XOR_HIGH         ; TO PUT CHAR IN
104         STOSB                    ; STORE IN REGEN BUFFER
105         LODSB
106    L10A:
107         MOV     ES:[DI+2000H-1],AL ; STORE IN SECOND HALF
108         ADD     DI,79             ; MOVE TO NEXT ROW IN REGEN
109         DEC     DH               ; DONE WITH LOOP
110         JNZ     L10
111         POP     SI
112         POP     DI               ; RECOVER REGEN POINTER
113         INC     DI               ; POINT TO NEXT CHAR POSITION
114         LOOP   HIGH_CHAR         ; MORE CHARS TO WRITE
115         JMP     VIDEO_RETURN
116
117    XOR_HIGH:
118         XOR     AL,ES:[DI]        ; EXCLUSIVE OR WITH CURRENT
119         STOSB                    ; STORE THE CODE POINT
120         LODSB                    ; AGAIN FOR ODD FIELD
121         XOR     AL,ES:[DI+2000H-1] ;
122         JMP     L10A             ; BACK TO MAINSTREAM
123

```

TABLE 6: GRAPHICS WRITE CHARACTER 320x200 COLOR MODE

```

124    |----- MEDIUM RESOLUTION WRITE
125    MED_RES_WRITE:
126         MOV     DL,BL             ; SAVE HIGH COLOR BIT
127         SAL     DI,1             ; OFFSET 2 SINCE 2 BYTES/CHAR
128         CALL    EXPAND_MED_COLOR ; EXPAND BL TO FULL WORD OF COLOR
129    MED_CHAR:
130         PUSH    DI               ; SAVE REGEN POINTER
131         PUSH    SI               ; SAVE THE CODE POINTER

```



```

132      MOV     DH,4           ; NUMBER OF LOOPS
133  L20:
134      LODSB           ; GET CODE POINT
135      CALL    EXPAND_BYTE  ; DOUBLE UP ALL THE BITS
136      AND     AX,BX       ; CONVERT THEM TO FOREGROUND COLOR ( 0 BACK )
137      TEST    DL,80H      ; IS THIS XOR FUNCTION
138      JZ      L20A       ; NO, STORE IT IN AS IT IS
139      XOR     AH,ES:[DI]   ; DO FUNCTION WITH HALF
140      XOR     AL,ES:[DI+1] ; AND WITH OTHER HALF
141  L20A:
142      MOV     ES:[DI],AH   ; STORE FIRST BYTE
143      MOV     ES:[DI+1],AL ; STORE SECOND BYTE
144
145      LODSB           ; GET CODE POINT
146      CALL    EXPAND_BYTE  ; CONVERT TO COLOR
147      AND     AX,BX       ; AGAIN, IS THIS XOR FUNCTION
148      TEST    DL,80H      ; AGAIN, IS THIS XOR FUNCTION
149      JZ      L20B       ; NO, JUST STORE THE VALUES
150      XOR     AH,ES:[DI+2000H] ; FUNCTION WITH FIRST HALF
151      XOR     AL,ES:[DI+2001H] ; AND WITH SECOND HALF
152  L20B:
153      MOV     ES:[DI+2000H],AH
154      MOV     ES:[DI+2000H+1],AL ; STORE IN SECOND PORTION OF BUFFER
155      ADD     DI,80        ; POINT TO NEXT LOCATION
156      DEC     DH
157      JNZ     L20         ; KEEP GOING
158      POP     SI          ; RECOVER CODE POINTER
159      POP     DI          ; RECOVER REGEN POINTER
160      ADD     DI,2         ; POINT TO NEXT CHAR POSITION
161      LOOP    MED_CHAR    ; MORE TO WRITE
162      JMP     VIDEO_RETURN
163  GRAPHICS_WRITE ENDP

```

TABLE 7: POSITION

```

349  |-----|
350  ; POSITION
351  ; THIS ROUTINE TAKES THE CURSOR POSITION CONTAINED IN
352  ; THE MEMORY LOCATION, AND CONVERTS IT INTO AN OFFSET
353  ; INTO THE REGEN BUFFER, ASSUMING ONE BYTE/CHAR.
354  ; FOR MEDIUM RESOLUTION GRAPHICS, THE NUMBER MUST
355  ; BE DOUBLED.
356  ; ENTRY -- NO REGISTERS, MEMORY LOCATION CURSOR_POSM IS USED
357  ; EXIT--
358  ; AX CONTAINS OFFSET INTO REGEN BUFFER
359  |-----|

```

```

361      PUBLIC  GRAPH_POSM
362  POSITION PROC NEAR
363      MOV     AX,CURSOR_POSM ; GET CURRENT CURSOR
364  GRAPH_POSM LABEL NEAR
365      PUSH   BX              ; SAVE REGISTER
366      MOV     BX,AX          ; SAVE A COPY OF CURRENT CURSOR
367      MOV     AL,AH          ; GET ROWS TO AL
368      MUL    BYTE PTR CRT_COLS ; MULTIPLY BY BYTES/COLUMN
369      SHL    AX,1            ; MULTIPLY * 4 SINCE 4 ROWS/BYTE
370      SHL    AX,1
371      SUB    BH,BH           ; ISOLATE COLUMN VALUE
372      ADD    AX,BX           ; DETERMINE OFFSET

```

```

17
373     POP     BX             ; RECOVER POINTER
374     RET
375 POSITION     ENDP
376 CODE      ENDS
377     END
    
```

TABLE 8: EXPAND MED COLOR

```

259 ;-----
260 ; EXPAND_MED_COLOR
261 ; THIS ROUTINE EXPANDS THE LOW 2 BITS IN BL TO
262 ; FILL THE ENTIRE BX REGISTER
263 ; ENTRY --
264 ; BL = COLOR TO BE USED ( LOW 2 BITS )
265 ; EXIT --
266 ; BX = COLOR TO BE USED ( 8 REPLICATIONS OF THE 2 COLOR BITS )
267 ;-----
    
```

```

268
269 EXPAND_MED_COLOR      PROC      NEAR
270     AND     BL,3       ; ISOLATE THE COLOR BITS
271     MOV     AL,BL      ; COPY TO AL
272     PUSH   CX         ; SAVE REGISTER
273     MOV     CX,3       ; NUMBER OF TIMES TO DO THIS
274 EXPAND_MED:
275     SAL     AL,1
276     SAL     AL,1       ; LEFT SHIFT BY 2
277     OR      BL,AL      ; ANOTHER COLOR VERSION INTO BL
278     LOOP   EXPAND_MED ; FILL ALL OF BL
279     MOV     BH,BL      ; FILL UPPER PORTION
280     POP     CX         ; REGISTER BACK
281     RET
282 EXPAND_MED_COLOR      ENDP
283
    
```

TABLE 9: EXPAND BYTE

```

284 ;-----
285 ; EXPAND_BYTE
286 ; THIS ROUTINE TAKES THE BYTE IN AL AND DOUBLES ALL
287 ; OF THE BITS, TURNING THE 8 BITS INTO 16 BITS.
288 ; THE RESULT IS LEFT IN AX
289 ;-----
    
```

```

290
291 EXPAND_BYTE      PROC      NEAR
292     PUSH   DX         ; SAVE REGISTER
293     PUSH   CX
294     PUSH   BX
295     MOV     DX,0       ; RESULT REGISTER
296     MOV     CX,1       ; MASK REGISTER
297 EXPAND_BYTE_LOOP:
298     MOV     BX,AX      ; BASE INTO TEMP
299     AND     BX,CX      ; USE MASK TO EXTRACT A BIT
300     OR      DX,BX     ; PUT INTO RESULT REGISTER
301     SHL     AX,1
302     SHL     CX,1       ; SHIFT BASE AND MASK BY 1
303     MOV     BX,AX      ; BASE TO TEMP
304     AND     BX,CX      ; EXTRACT THE SAME BIT
305     OR      DX,BX     ; PUT INTO RESULT
306     SHL     CX,1       ; SHIFT ONLY MASK NOW, MOVING TO NEXT BASE
307     JNC    EXPAND_BYTE_LOOP ; USE MASK BIT COMING OUT TO TERMINATE
308     MOV     AX,DX      ; RESULT TO FARM REGISTER
309     POP     BX
    
```

```

19
310      POP    CX      ; RECOVER REGISTERS
311      POP    DX
312      RET
313  EXPAND_BYTE  ENDP

```

TABLE 10: GRAPHICS READ CHARACTER (HIGH RESOLUTION)

```

164
165 ;-----
166 ; GRAPHICS READ
167 ;-----
168      PUBLIC  GRAPHICS_READ
169  GRAPHICS_READ  PROC  NEAR
170
171      CALL    POSITION      ; CONVERTED TO OFFSET IN REGEN
172      MOV     SI,AX        ; SAVE IN SI
173      SUB     SP,8        ; ALLOCATE SPACE TO SAVE THE READ CODE POINT
174      MOV     BP,SP       ; POINTER TO SAVE AREA
175
176 ;----- DETERMINE GRAPHICS MODES
177
178      CMP     CRT_MODE,6
179      PUSH   ES
180      POP     DS          ; POINT TO REGEN SEGMENT
181      JC     MED_RES_READ ; MEDIUM RESOLUTION
182
183 ;----- HIGH RESOLUTION READ
184
185 ;----- GET VALUES FROM REGEN BUFFER AND CONVERT TO CODE POINT
186  HIGH_READ:
187      MOV     DH,4        ; NUMBER OF PASSES
188  L100:
189      MOV     AL,[SI]     ; GET FIRST BYTE
190      MOV     [BP],AL     ; SAVE IN STORAGE AREA
191      INC     BP          ; NEXT LOCATION
192      MOV     AL,[SI+2000H] ; GET LOWER REGION BYTE
193      MOV     [BP],AL     ; ADJUST AND STORE
194      INC     BP
195      ADD     SI,80       ; POINTER INTO REGEN
196      DEC     DH          ; LOOP CONTROL
197      JNZ    L100        ; DO IT SOME MORE
198      JMP     FIND_CHAR   ; GO MATCH THE SAVED CODE POINTS
199

```

TABLE 11: GRAPHICS READ CHARACTER (MEDIUM RESOLUTION)

```

200 ;----- MEDIUM RESOLUTION READ
201  MED_RES_READ:
202      SAL     SI,1        ; OFFSET#2 SINCE 2 BYTES/CHAR
203      MOV     DH,4        ; NUMBER OF PASSES
204  L110:
205      CALL    MED_READ_BYTE ; GET PAIR BYTES FROM REGEN INTO SINGLE SAVE
206      ADD     SI,2000H     ; GO TO LOWER REGION
207      CALL    MED_READ_BYTE ; GET THIS PAIR INTO SAVE
208      SUB     SI,2000H-80 ; ADJUST POINTER BACK INTO UPPER
209      DEC     DH
210      JNZ    L110        ; KEEP GOING UNTIL ALL 8 DONE
211
212 ;----- SAVE AREA HAS CHARACTER IN IT, MATCH IT

```

```

213 FIND_CHAR:
214     MOV     DI,OFFSET CRT_CHAR_GEN ; ESTABLISH ADDRESSING TO CODE POINTS
215     PUSH   CS
216     POP     ES                     ; CODE POINTS IN CS
217     SUB     BP,8                   ; ADJUST POINTER TO BEGINNING OF SAVE AREA

218     MOV     SI,BP
219     CLD
220     MOV     AL,0                   ; ENSURE DIRECTION
221     ; CURRENT CODE POINT BEING MATCHED
222     L190:  PUSH   SS                 ; ESTABLISH ADDRESSING TO STACK
223     POP     DS                 ; FOR THE STRING COMPARE
224     MOV     DX,128                ; NUMBER TO TEST AGAINST
225     L200:
226     PUSH   SI                     ; SAVE SAVE AREA POINTER
227     PUSH   DI                     ; SAVE CODE POINTER
228     MOV     CX,8                   ; NUMBER OF BYTES TO MATCH
229     REPE   CMPSB                  ; COMPARE THE 8 BYTES

230     POP     DI                     ; RECOVER THE POINTERS
231     POP     SI
232     JZ     FOUND                  ; IF ZERO FLAG SET, THEN MATCH OCCURRED
233     INC     AL                     ; NO MATCH, MOVE ON TO NEXT
234     ADD     DI,8                   ; NEXT CODE POINT
235     DEC     DX                     ; LOOP CONTROL
236     JNZ    L200                   ; DO ALL OF THEM
237
238     ;----- CHAR NOT MATCHED, MIGHT BE IN USER SUPPLIED SECOND HALF
239
240     CMP     AL,0                   ; AL < 0 IF ONLY 1ST HALF SCANNED
241     JE     FOUND                  ; IF = 0, THEN ALL HAS BEEN SCANNED
242     SUB     AX,AX
243     MOV     DS,AX                 ; ESTABLISH ADDRESSING TO VECTOR
244     ASSUME DS:DUMMY
245     LES     DI,EXT_PTR             ; GET POINTER
246     MOV     AX,ES                 ; SEE IF THE POINTER REALLY EXISTS
247     OR     AX,DI                  ; IF ALL 0, THEN DOESN'T EXIST
248     JZ     FOUND                  ; NO SENSE LOOKING
249     MOV     AL,128                ; ORIGIN FOR SECOND HALF
250     JMP     L190                   ; GO BACK AND TRY FOR IT
251     ASSUME DS:DATA
252
253     ;----- CHARACTER IS FOUND ( AL=0 IF NOT FOUND )
254     FOUND:
255     ADD     SP,8                   ; READJUST THE STACK, THROW AWAY SAVE
256     JMP     VIDEO_RETURN          ; ALL DONE
257     GRAPHICS_READ ENDP
258

```

TABLE 12: MED READ BYTE

```

314
315 ;-----
316 ; MED_READ_BYTE
317 ; THIS ROUTINE WILL TAKE 2 BYTES FROM THE REGEN BUFFER,
318 ; COMPARE AGAINST THE CURRENT FOREGROUND COLOR, AND PLACE
319 ; THE CORRESPONDING ON/OFF BIT PATTERN INTO THE CURRENT

```

```

320 ; POSITION IN THE SAVE AREA
321 ; ENTRY --
322 ; SI,DS = POINTER TO REGEN AREA OF INTEREST
323 ; BX = EXPANDED FOREGROUND COLOR
324 ; BP = POINTER TO SAVE AREA
325 ; EXIT --
326 ; BP IS INCREMENT AFTER SAVE
327 ; -----
328
329 MED_READ_BYTE PROC NEAR
330     MOV     AH,[SI]      ; GET FIRST BYTE
331     MOV     AL,[SI+1]    ; GET SECCND BYTE
332     MOV     CX,0C000H    ; 2 BIT MASK TO TEST THE ENTRIES
333     MOV     DL,0         ; RESULT REGISTER
334 L300:
335     TEST    AX,CX        ; IS THIS SECTION BACKGROUND?
336     CLC     ; CLEAR CARRY IN HOPES THAT IT IS
337     JZ     L310         ; IF ZERO, IT IS BACKGROUND
338     STC     ; WASN'T, SO SET CARRY
339 L310:
340     RCL    DL,1         ; MOVE THAT BIT INTO THE RESULT
341     SHR    CX,1
342     SHR    CX,1         ; MOVE THE MASK TO THE RIGHT BY 2 BITS
343     JNC    L300        ; DO IT AGAIN IF MASK DIDN'T FALL OUT
344     MOV    [BP],DL     ; STORE RESULT IN SAVE AREA
345     INC    BP          ; ADJUST POINTER
346     RET     ; ALL DONE
347 MED_READ_BYTE ENDP
348

```

TABLE 13: VIDEO3 GRAPHICS

```

LINE SOURCE
1 $TITLE('VIDEO3 GRAPHICS R/W DOT -- SCROLL UP/DOWN')
2 $PAGELENGTH(43)
3 ; -----
4 ; THIS MODULE CONTAINS THE ROUTINES USED DURING GRAPHICS OPERATIONS
5 ; THE ROUTINES INCLUDE:
6 ; READ/WRITE DOT
7 ; SCROLL UP/DOWN
8 ; -----
9
10 DATA SEGMENT BYTE PUBLIC
11     EXTRN CRT_MODE:BYTE,CRT_COLS:BYTE
12 DATA ENDS
13
14 CODE SEGMENT BYTE PUBLIC
15     ASSUME CS:CODE,DS:DATA,ES:DATA
16     EXTRN VIDEO_RETURN:NEAR
17 ODD_FLD EQU 2000H ; OFFSET TO ODD FIELD OF GRAPHICS
18

```

TABLE 14: SCROLL UP - PART 1

```

142 ; -----
143 ; SCROLL UP
144 ; THIS ROUTINE SCROLLS UP THE INFORMATION ON THE CRT
145 ; ENTRY --

```

```

146 ; CH,CL = UPPER LEFT CORNER OF REGION TO SCROLL
147 ; DH,DL = LOWER RIGHT CORNER OF REGION TO SCROLL
148 ; BOTH OF THE ABOVE ARE IN CHARACTER POSITIONS
149 ; BH = FILL VALUE FOR BLANKED LINES
150 ; AL = # LINES TO SCROLL (AL=0 MEANS BLANK THE ENTIRE FIELD)
151 ; DS = DATA SEGMENT
152 ; ES = REGEN SEGMENT
153 ; EXIT --
154 ; NOTHING, THE SCREEN IS SCROLLED
155 ;-----
156 PUBLIC GRAPHICS_UP,GRAPHICS_DOWN
157 EXTRN GRAPH_POSN:NEAR
158
159 GRAPHICS_UP PROC NEAR
160 MOV BL,AL ; SAVE LINE COUNT IN BL
161 MOV AX,CX ; GET UPPER LEFT POSITION INTO AX REG
162
163 ;----- USE CHARACTER SUBROUTINE FOR POSITIONING
164 ;----- ADDRESS RETURNED IS MULTIPLIED BY 2 FROM CORRECT VALUE
165
166 CALL GRAPH_POSN
167 MOV DI,AX ; SAVE RESULT AS DESTINATION ADDRESS
168
169 ;----- DETERMINE SIZE OF WINDOW
170
171 SUB DX,CX
172 ADD DX,101H ; ADJUST VALUES
173 SAL DH,1 ; MULTIPLY # ROWS BY 4 SINCE 8 VERT DOTS/CHAR
174 SAL DH,1 ; AND EVEN/ODD ROWS
175
176 ;----- DETERMINE CRT MODE
177
178 CMP CRT_MODE,6 ; TEST FOR MEDIUM RES
179 JNC FIND_SOURCE
180
181 MED_RES_UP:
182 SAL DL,1 ; # COLUMNS * 2, SINCE 2 BYTES/CHAR
183 SAL DI,1 ; OFFSET *2 SINCE 2 BYTES/CHAR
184
185 ;----- DETERMINE THE SOURCE ADDRESS IN THE BUFFER
186 FIND_SOURCE:
187 PUSH ES ; GET SEGMENTS BOTH POINTING TO REGEN
188 POP DS
189 SUB CH,CH ; ZERO TO HIGH OF COUNT REG
190 SAL BL,1 ; MULTIPLY NUMBER OF LINES BY 4
191 SAL BL,1
192 JZ BLANK_FIELD ; IF ZERO, THEN BLANK ENTIRE FIELD
193 MOV AL,BL ; GET NUMBER OF LINES IN AL
194 MOV AH,80 ; 80 BYTES/ROW
195 MUL AH ; DETERMINE OFFSET TO SOURCE
196 MOV SI,DI ; SET UP SOURCE
197 ADD SI,AX ; ADD IN OFFSET TO IT
198 MOV AH,DH ; NUMBER OF ROWS IN FIELD
199 SUB AH,BL ; DETERMINE NUMBER TO MOVE
200
201 ;----- LOOP THROUGH, MOVING ONE ROW AT A TIME, BOTH EVEN AND ODD FIELDS

```

```

202 ROW_LOOP:
203     CALL    ROW_MOVE          ; MOVE ONE ROW
204     SUB     SI,ODD_FLD-80    ; MOVE TO NEXT ROW
205     SUB     DI,ODD_FLD-80
206     DEC     AH                ; NUMBER OF ROWS TO MOVE
207     JNZ    ROW_LOOP         ; CONTINUE TILL ALL MOVED
208
209 ;----- FILL IN THE VACATED LINE(S)
210 CLEAR_ENTRY:
211     MOV     AL,BH            ; ATTRIBUTE TO FILL WITH
212 CLEAR_LOOP:
213     CALL    ROW_CLEAR        ; CLEAR THAT ROW
214     SUB     DI,ODD_FLD-80    ; POINT TO NEXT LINE
215     DEC     BL                ; NUMBER OF LINES TO FILL
216     JNZ    CLEAR_LOOP
217     JMP     VIDEO_RETURN     ; EVERYTHING DONE
218
219 BLANK_FIELD:
220     MOV     BL,DH            ; SET BLANK COUNT TO EVERYTHING IN FIELD
221     JMP     CLEAR_ENTRY      ; CLEAR THE FIELD
222 GRAPHICS_UP   ENDP
223 +1 $EJECT

```

TABLE 16: SCROLL DOWN - PART 1

```

LINE SOURCE
224 ;-----
225 ; SCROLL DOWN
226 ; THIS ROUTINE SCROLLS DOWN THE INFORMATION ON THE CRT
227 ; ENTRY --
228 ; CH,CL = UPPER LEFT CORNER OF REGION TO SCROLL
229 ; DH,DL = LOWER RIGHT CORNER OF REGION TO SCROLL
230 ; BOTH OF THE ABOVE ARE IN CHARACTER POSITIONS
231 ; BH = FILL VALUE FOR BLANKED LINES
232 ; AL = # LINES TO SCROLL (AL=0 MEANS BLANK THE ENTIRE FIELD)
233 ; DS = DATA SEGMENT
234 ; ES = REGEN SEGMENT
235 ; EXIT --
236 ; NOTHING, THE SCREEN IS SCROLLED
237 ;-----
238
239 GRAPHICS_DOWN PROC NEAR
240     STD                ; SET DIRECTION
241     MOV     BL,AL       ; SAVE LINE COUNT IN BL
242     MOV     AX,DX       ; GET LOWER RIGHT POSITION INTO AX REG
243
244 ;----- USE CHARACTER SUBROUTINE FOR POSITIONING
245 ;----- ADDRESS RETURNED IS MULTIPLIED BY 2 FROM CORRECT VALUE
246
247     CALL    GRAPH_POSM
248     MOV     DI,AX       ; SAVE RESULT AS DESTINATION ADDRESS
249
250 ;----- DETERMINE SIZE OF WINDOW
251
252     SUB     DX,CX

```

```

253      ADD    DX,101H      ; ADJUST VALUES
254      SAL    DH,1        ; MULTIPLY # ROWS BY 4 SINCE 3 VERT DOTS/CHAR
255      SAL    DH,1        ; AND EVEN/ODD ROWS
256
257      ;----- DETERMINE CRT MODE
258
259      CMP    CRT_MODE,6   ; TEST FOR MEDIUM RES
260      JNC    FIND_SOURCE_DOWN

261
262      MED_RES_DOWN:
263      SAL    DL,1        ; # COLUMNS * 2, SINCE 2 BYTES/CHAR (OFFSET OK)
264      SAL    DI,1        ; OFFSET *2 SINCE 2 BYTES/CHAR
265      INC    DI          ; POINT TO LAST BYTE
266

```

TABLE 17: SCROLL DOWN - PART 2

```

267      ;----- DETERMINE THE SOURCE ADDRESS IN THE BUFFER
268      FIND_SOURCE_DOWN:
269      PUSH   ES          ; BOTH SEGMENTS TO REGEN
270      POP    DS
271      SUB    CH,CH       ; ZERO TO HIGH OF COUNT REG
272      ADD    DI,240     ; POINT TO LAST ROW OF PIXELS
273      SAL    BL,1       ; MULTIPLY NUMBER OF LINES BY 4
274      SAL    BL,1
275      JZ     BLANK_FIELD_DOWN ; IF ZERO, THEN BLANK ENTIRE FIELD
276      MOV    AL,BL      ; GET NUMBER OF LINES IN AL
277      MOV    AH,80      ; 80 BYTES/ROW
278      MUL    AH         ; DETERMINE OFFSET TO SOURCE
279      MOV    SI,DI      ; SET UP SOURCE
280      SUB    SI,AX      ; SUBTRACT THE OFFSET
281      MOV    AH,DH      ; NUMBER OF ROWS IN FIELD
282      SUB    AH,BL      ; DETERMINE NUMBER TO MOVE
283
284      ;----- LOOP THROUGH, MOVING ONE ROW AT A TIME, BOTH EVEN AND ODD FIELDS
285      ROW_LOOP_DOWN:
286      CALL   ROW_MOVE    ; MOVE ONE ROW
287      SUB    SI,ODD_FLD+80 ; MOVE TO NEXT ROW
288      SUB    DI,ODD_FLD+80
289      DEC    AH         ; NUMBER OF ROWS TO MOVE
290      JNZ   ROW_LOOP_DOWN ; CONTINUE TILL ALL MOVED
291
292      ;----- FILL IN THE VACATED LINE(S)
293      CLEAR_ENTRY_DOWN:
294      MOV    AL,BH      ; ATTRIBUTE TO FILL WITH
295      CLEAR_LOOP_DOWN:
296      CALL   ROW_CLEAR   ; CLEAR A ROW
297      SUB    DI,ODD_FLD+80 ; POINT TO NEXT LINE
298      DEC    BL         ; NUMBER OF LINES TO FILL
299      JNZ   CLEAR_LOOP_DOWN
300      CLD              ; RESET THE DIRECTION FLAG
301      JMP    VIDEO_RETURN ; EVERYTHING DONE
302
303      BLANK_FIELD_DOWN:

```



```

304      MOV     BL,DH      ; SET BLANK COUNT TO EVERYTHING IN FIELD
305      JMP     CLEAR_ENTRY_DOWN  ; CLEAR THE FIELD
306  GRAPHICS_DOWN  ENDP
307

```

TABLE 18: ROW MOVE

```

308  ;----- ROUTINE TO MOVE ONE ROW OF INFORMATION
309
310  ROW_MOVE      PROC     NEAR
311      MOV     CL,DL      ; NUMBER OF BYTES IN THE ROW
312      PUSH   SI
313      PUSH   DI      ; SAVE POINTERS
314      REP     MOVSB     ; MOVE THE EVEN FIELD
315      POP    DI
316      POP    SI
317      ADD    SI,ODD_FLD
318      ADD    DI,ODD_FLD      ; POINT TO THE ODD FIELD
319      PUSH   SI
320      PUSH   DI      ; SAVE THE POINTERS
321      MOV     CL,DL      ; COUNT BACK
322      REP     MOVSB     ; MOVE THE ODD FIELD
323      POP    DI
324      POP    SI      ; POINTERS BACK
325      RET
326  ROW_MOVE      ENDP

```

TABLE 19: ROW CLEAR

```

327  ;----- CLEAR A SINGLE ROW
328
329
330  ROW_CLEAR     PROC     NEAR
331      MOV     CL,DL      ; NUMBER OF BYTES IN FIELD
332      PUSH   DI      ; SAVE POINTER
333      REP     STOSB     ; STORE THE NEW VALUE
334      POP    DI      ; POINTER BACK
335      ADD    DI,ODD_FLD      ; POINT TO ODD FIELD
336      PUSH   DI
337      MOV     CL,DL
338      REP     STOSB     ; FILL THE ODD FIELD
339      POP    DI
340      RET      ; RETURN TO CALLER
341  ROW_CLEAR     ENDP
342  CODE          ENDS
343  END

```

While the invention has been described with respect to preferred embodiments thereof, it is to be understood that the foregoing and other modifications and varia-

tions may be made without departing from the scope and spirit thereof.

I claim:

[1. A raster scan video display control apparatus of the type including a graphic video display refresh buffer operable in an all points addressable mode for refreshing said display with graphics data, a processor for writing graphic data into said display refresh buffer, and a character storage for storing the character dot patterns of a display character font, characterized by:

means for selecting a character to be displayed; and programmable control means referenced by said processor for

- (1) loading from said storage into said graphic video display refresh buffer a character dot pattern corresponding to the character to be displayed;
- (2) expanding the selected character dot pattern into a predetermined pixel format and then color encoding the expanded dot pattern to establish a resultant expanded/encoded dot pattern; and
- (3) loading said expanded/encoded dot pattern into said graphic video display refresh buffer.]

[2. A raster scan video display control apparatus of the type including a graphic video display refresh buffer operable in an all points addressable mode for refreshing said display with graphics data, a processor for writing graphic data into said display refresh buffer, and a character storage for storing the character dot patterns of a display character font, characterized by:

means for selecting a character to be displayed; and programmable control means referenced by said processor selectively for loading from said storage into said graphic video display refresh buffer a character dot pattern corresponding to the character to be displayed and for reading a previously displayed character by comparing a character dot pattern previously loaded into said graphic video display buffer with successive character dot patterns selected from said character storage.]

3. A method for writing a text character on a raster scan all points addressable video display, comprising the steps of:

- retrieving from storage the graphic dot image of the character to be written;
- expanding said graphic image to a selected pixel and color format; and
- storing the expanded dot image in a display refresh buffer.

4. A method for reading a selected text character previously written as an expanded dot image into a display refresh buffer from a graphic dot image stored in a storage associated with an all points addressable video display, comprising the steps of:

- retrieving from said display refresh buffer the expanded dot image of the selected character to be read;
- converting the expanded dot image to be read to a converted dot image corresponding to the format of graphic dot image in the storage;
- obtaining from storage the graphic dot image of a comparison character;
- comparing the dot image of the comparison character with said converted dot image; and
- repeating the obtaining and comparing steps until the dot image of the comparison character matches said converted dot image.

5. A method for operating a computing apparatus that controls a graphics display to write a text character onto a display screen, the computing apparatus including a processor referencing a store, and a display refresh

buffer, characterized in that the method comprises the steps of:

- establishing addressability to the location in said display refresh buffer to receive a selected display text character;
- establishing addressability to the location in said store containing a dot image of said selected display text character;
- fetching one portion of said dot image from said store;
- expanding said portion of said dot image according to a selected pixel format to provide an expanded dot image portion;
- modifying said expanded dot image portion to encode a desired color; and
- storing the expanded dot image portion as modified in said display refresh buffer; and
- repeating said fetching, expanding, modifying and storing steps for each portion of said dot image to load into said display refresh buffer the selected display text character.

6. The method of claim [7,] 5, characterized by the steps of:

- refreshing a raster scan display with alternate raster scan lines refreshed from offset locations of said display refresh buffer; and
- storing alternating dot image portions in offset locations of said display refresh buffer as part of said storing step.

7. The method of claim [7,] 5, characterized in that said storing step is performed by exclusive 'ORing each dot image portion with a corresponding portion of said modified expanded dot image previously stored in said display refresh buffer.

8. The method of claim 5, characterized in that said expanding step and said modifying step are for the purpose of writing a text character in color and said expanding step and modifying step are eliminated when writing the text character in black and white.

9. A method for operating a computing apparatus that controls a graphics display to read a text character previously written onto said graphics display, the computing apparatus including a processor referencing a store, and a display refresh buffer, comprising the steps of:

- retrieving from said display refresh buffer a dot image of the character to be read;
- storing the dot image of the character to be read in a save area in said store;
- sequentially retrieving from said store respective dot images of possible display text characters and comparing each respective dot image with the dot image in the save area; and
- repeating the retrieving and comparing steps until a respective dot image matches the dot image in said save area, thereby concluding reading of the text characters.

10. A raster scan video display control apparatus of the type including a graphic video display refresh buffer operable in an all points addressable mode for refreshing said display with graphics data, a processor for writing graphics data into said display refresh buffer, and a character storage for storing the character dot patterns of a display character font, comprising means for selecting a character to be displayed, and means for loading from said storage into said graphic video display refresh buffer a character dot pattern corresponding to the character to be displayed and for reading a previously displayed character by comparing

a character dot pattern previously loaded into said graphic video display buffer with successive character dot patterns selected from said character storage.

11. A raster scan video display control apparatus of the type including a graphic video display refresh buffer for refreshing said display with graphics data, a processor for writing graphics data into said display refresh buffer, and a character storage for storing the character dot patterns of a display character font, comprising means for selecting a character to be displayed, means for reading out said character from said character storage in a first format, means for expanding the selected character dot pattern into a predetermined pixel format and then color encoding the expanded dot pattern to establish a resultant expanded/encoded dot pattern, and loading said expanded/encoded dot pattern into said graphic video display refresh buffer.

12. In a display apparatus for writing a text character onto a video display and including a means for retrieving the graphic dot image of the character to be written from a character storage, the improvement comprising means for expanding a retrieved graphic dot image into a selected pixel and color format, and means for storing the expanded dot image in a display refresh buffer.

13. Video display control apparatus of the type including a video display buffer for holding information patterns directly specifying the tracing of patterns on a display screen, a processor for writing information patterns into said buffer, and font storage means for storing a font of displayable information patterns, characterized by:

- means for selecting code representations of patterns to be displayed;
- means responsive to said selected representations for extracting first information patterns corresponding to said patterns extracted from said font storage means;
- means for converting said extracted first patterns into corresponding second information patterns for producing the same display patterns as said first patterns but with a different image characteristic; and
- means for entering said second information patterns into said display buffer.

14. Video display control apparatus of the type including a video display buffer for holding information patterns directly specifying the tracing of image patterns on a display screen, a processor for writing information patterns into said buffer, and font storage means for storing a font of displayable information patterns, characterized by:

- means for selecting code representations of image patterns to be displayed;
- means responsive to said selected representations for extracting corresponding information patterns from said font storing means;
- means responsive to said extracting means for storing information patterns corresponding to said extracted patterns in said display buffer;
- means for reading information pattern patterns from said display buffer; and
- means coupled to said reading means and said font storage means for converting information patterns read from said buffer into corresponding code representations.

15. Video display control apparatus in accordance with claim 14 wherein said converting means comprises:

means for comparing each information pattern read from said display buffer with patterns stored in said font storage means; and

means responsive to a match between patterns compared by said comparing means for developing a code representation corresponding to the matched pattern.

16. Video display control apparatus in accordance with claim 14 wherein said means for storing corresponding patterns in said display buffer comprises:

- means for converting each pattern extracted from said font storage into a corresponding pattern having a different display image characteristic than the extracted pattern; and
- means for writing such corresponding patterns into said display buffer.

17. A method for creating image displays of information patterns comprising:

- forming code representations of information patterns to be displayed;
- converting said code representations into corresponding first information patterns corresponding to images to be displayed;
- converting said first information patterns into second information patterns for directly controlling the tracing of associated image patterns on an image display; said second information patterns having associated image characteristics different from those of the respective first information patterns; and
- storing said second information patterns in a display buffer capable of directly controlling the formation of images on an image display.

18. A method for creating image displays of information patterns comprising:

- forming code representations of information patterns to be displayed;
- converting said code representations into corresponding information patterns to be displayed;
- storing said information patterns in a display buffer capable of directly controlling the formation of images on an image display;
- reading information patterns from said display buffer; and
- converting said information patterns read from said display buffer into corresponding code representations.

19. The display formation method of claim 18 wherein: said step of converting said code representations into corresponding information patterns comprises:

- converting each code representation into a first associated information pattern having a first associated image formation characteristic; and
- converting each first associated information pattern into a different second information pattern having an associated second image formation characteristic different from the respective first characteristic.

20. The display formation method of claim 19 wherein said step of converting said information patterns into code representations comprises:

- converting each information pattern into a corresponding standardized information pattern having a different image formation characteristic; and
- converting each said corresponding pattern into a corresponding standardized code representation.

* * * * *

UNITED STATES PATENT AND TRADEMARK OFFICE
CERTIFICATE OF CORRECTION

PATENT NO. : Re 32,201

DATED : July 8, 1986

INVENTOR(S) : David J. Bradley

It is certified that error appears in the above-identified patent and that said Letters Patent is hereby corrected as shown below:

Column 34, line 32, in claim 7, line 3, change "said" to --a--;

Column 35, line 56, in claim 14, line 15, delete "pattern".

**Signed and Sealed this
Twelfth Day of February, 1991**

Attest:

HARRY F. MANBECK, JR.

Attesting Officer

Commissioner of Patents and Trademarks

REEXAMINATION CERTIFICATE (1108th)

United States Patent [19]

[11] B1 Re. 32,201

Bradley

[45] Certificate Issued Aug. 1, 1989

[54] APPARATUS AND METHOD FOR READING AND WRITING TEXT CHARACTERS IN A GRAPHICS DISPLAY

[75] Inventor: David J. Bradley, Boca Raton, Fla.

[73] Assignee: International Business Machines Corp., Armonk, N.Y.

Reexamination Request:

No. 90/001,645, Nov. 23, 1988

Reexamination Certificate for:

Patent No.: Re. 32,201
Issued: Jul. 8, 1986
Appl. No.: 638,340
Filed: Aug. 6, 1984

Related U.S. Patent Documents

Reissue of:

[64] Patent No.: 4,408,200
Issued: Oct. 4, 1983
Appl. No.: 292,084
Filed: Aug. 12, 1981

[51] Int. Cl.⁴ G09G 1/28

[52] U.S. Cl. 340/747; 340/703;
340/750

[58] Field of Search 340/703, 747, 750

[56] References Cited

U.S. PATENT DOCUMENTS

3,293,614 12/1966 Fenimore et al. .
3,312,953 4/1967 Wang et al. .
3,668,687 6/1972 Hale .
3,778,810 12/1973 Hayashi .
3,873,972 3/1975 Levine .
3,895,357 7/1975 Schwartz et al. .
3,906,480 9/1975 Schwartz et al. .
3,967,268 6/1976 Roberts .
4,012,735 3/1977 Keane .
4,026,555 5/1977 Kirschner et al. .
4,063,232 12/1977 Fernald .
4,078,249 3/1978 Lelke et al. .
4,094,000 6/1978 Brudevold .
4,149,145 4/1979 Hartke et al. .
4,180,805 12/1979 Burson .
4,197,590 4/1980 Sukonick et al. .
4,225,586 9/1980 Langdon, Jr. et al. .
4,250,056 2/1981 Haag et al. .
4,272,276 6/1981 Lacy .
4,283,724 8/1981 Edwards .
4,297,693 10/1981 Parsons .
4,298,895 11/1981 Duvall et al. .
4,330,834 5/1982 Murphy .
4,338,599 7/1982 Leininger .
4,342,029 7/1982 Hofmanis et al. .
4,394,650 7/1983 Long et al. .
4,404,552 9/1983 Hirahata et al. .
4,520,356 5/1985 O'Keefe et al. .

FOREIGN PATENT DOCUMENTS

3046972 9/1981 Fed. Rep. of Germany .

OTHER PUBLICATIONS

William M. Newman, Robert F. Sproul, "Principles of Interactive Computer Graphics"; 2nd Ed., McGraw-Hill Book 1979, pp. 220-223, 251, 277-281.

Robert F. Sproul, "Raster Graphics for Interactive Programming Environments"; ACM (1979), pp. 83-93. Motorola Semiconductor Product Description MC 6845-CRT Controller, copyrighted 1977.

Computer Graphics in Color (P. B. Denes) Bell Laboratories Record, May 1974, pp. 139-146.

B. E. Bliss et al., "Time-Shared Communication with Key-CRT Display Terminals", 3/73, IBM Technical Disclosure Bulletin, vol. 15, No. 10, 3/73, pp. 3056-3059.

A. J. Heimsoth, "Display of Characters on a Graphic System", 1/80, pp. 3544-3546, IBM Technical Disclosure Bulletin, V22, N8B.

D. C. Clarke, "Method for Correlating Graphical Data on a Interactive Display", 4/79, pp. 4658-4659, IBM Technical Disclosure Bulletin, V21, No. 11.

D. P. Attwood, "Variable-Size Buffer Control for Plotted Graphic Output", 3/78, pp. 4157-4158, IBM Technical Disclosure Bulletin, V20, No. 10.

D. A. Kummer, "All-Points-Addressable Raster Scan Graphics for Cathode Ray Tube with Dual-Ported Bit Map", 1/81, pp. 3553-3555, IBM Technical Disclosure Bulletin, V23, N8.

R. A. Schulz, "Interactive Graphics Terminal": 10/80, pp. 1770-1779, IBM Technical Disclosure Bulletin, V23, N5.

R. K. DeBry, "Character Graphics Using Programmable Character Font", 10/80, pp. 2001-2002 IBM Technical Disclosure Bulletin, V23, N5.

R. K. DeBry et al., "Enhanced Display Extended Character and Graphics Functions", 10/80, pp. 2003-2004, IBM Technical Disclosure Bulletin, V23, N5.

Primary Examiner—David L. Trafton

[57] ABSTRACT

Apparatus and method for writing text characters to a raster scan video display operated in an all-points-addressable, or graphics, mode, and for reading characters thus written. A graphic video display buffer directly refreshes the display with graphics data received from a microprogrammed processor. The processor writes a character to the display by selecting and loading into the graphics video display buffer a text character dot pattern retrieved from main storage, and reads a character previously written by comparing a dot pattern retrieved from the display buffer with dot patterns retrieved from main storage. To write a character to the display in color, the graphic dot image of a selected character retrieved from main storage is expanded to a selected pixel and color format, and stored in the graphics video display buffer. Text characters thus written in color are read by retrieving from the display buffer the expanded dot image, restoring the expanded dot image to its original form, and comparing the restored dot image with graphic dot images retrieved from storage.

**REEXAMINATION CERTIFICATE
ISSUED UNDER 35 U.S.C. 307**

THE PATENT IS HEREBY AMENDED AS
INDICATED BELOW.

Matter enclosed in heavy brackets [] appeared in the patent, but has been deleted and is no longer a part of the patent; matter printed in italics indicates additions made to the patent.

AS A RESULT OF REEXAMINATION, IT HAS BEEN DETERMINED THAT:

The patentability of claims 4, 9, 10, 14-16 and 18-20 is confirmed.

Claims 1 and 2 were previously cancelled.

Claims 3, 5, 11-13 and 17 are determined to be patentable as amended.

Claims 6-8, dependent on an amended claim are determined to be patentable.

3. A method for writing a text character on a raster scan all points addressable video display, comprising the steps of:

retrieving from storage the graphic dot image of the text character to be written, *each dot being represented by a single bit;*

expanding said graphic dot image to a selected pixel and color format *by duplicating each bit and logically combining the bits representing each dot with encoded color information;* and

storing the expanded dot image *by placing the bits representing each dot in contiguous address memory locations in a display refresh buffer.*

5. A method for operating a computing apparatus that controls a graphics display to write a text character onto a display screen, the computing apparatus including a processor referencing a store, and a display refresh buffer *comprising a plurality of memory locations*, characterized in that the method comprises the steps of:

establishing addressability to the location in said display refresh buffer to receive a selected display text character;

establishing addressability to the location in said store containing a dot image of said selected display text character;

fetching one portion of said dot image from said store, *each dot being represented by a single bit;*

expanding said portion of said dot image according to a selected pixel format *by duplicating each bit to provide an expanded dot image portion;*

modifying said expanded dot image portion *by logically combining the bits representing each dot with encoded color information to provide an encoded color dot image portion* [to encode a desired color]; and

storing the [expanded] bits representing each dot in the encoded color dot image portion [as modified] in contiguous address memory locations in said display refresh buffer; and

repeating said fetching, expanding, modifying and storing steps for each portion of said dot image to

load into said display refresh buffer the selected display text character.

11. A raster scan video display control apparatus of the type including a graphic video display refresh buffer *comprising a plurality of memory locations* for refreshing said display with graphics data, a processor for writing graphics data into said display refresh buffer, and a character storage for storing the character dot patterns of a display character font, comprising means for selecting a character to be displayed, means for reading out said character from said character storage in a first dot format *comprising one bit per dot*, means for expanding *by duplicating* the selected character dot pattern into a predetermined pixel format *comprising two identical bits per pixel* and then color encoding the expanded dot pattern *by logically combining encoded color information with said expanded dot pattern* to establish a resultant expanded/encoded dot pattern, and loading the bits representing each dot of said expanded/encoded dot pattern into contiguous address memory locations in said graphic video display refresh buffer.

12. In a display apparatus for writing a text character onto a video display and including a means for retrieving the graphic dot image of the character to be written from a character storage, *each dot in said image being represented by a single bit*, the improvement comprising means for expanding a retrieved graphic dot image into a selected pixel and color format *by duplicating each bit n times and logically combining the n bits representing each dot with n bits of encoded color information, where n is an integer, and*

means for storing the expanded dot image in a display refresh buffer *by entering the n bits representing each dot of said expanded dot image into n contiguous address memory locations.*

13. Video display control apparatus of the type including a video display buffer *having a plurality of memory locations* for holding information patterns directly specifying the tracing of multi-element patterns on a display screen, a processor for writing information patterns into said buffer, and font storage means for storing a font of displayable information patterns, characterized by:

means for selecting code representations of patterns to be displayed;

means responsive to said selected representations for extracting first multi-element information patterns corresponding to said multi-element patterns extracted from said font storage means, *each element of said first patterns being represented by a first number of bits n, where n is an integer;*

means for converting said extracted first patterns into corresponding second multi-element information patterns, *each element of said second patterns being represented by a second number of bits 2n*, for producing the same display patterns as said first patterns but with a different image characteristic; and means for entering said second multi-element information patterns into said display buffer *by storing the 2n bits representing each element of said second patterns in 2n contiguous address memory locations.*

17. A method for creating image displays of multi-element information patterns comprising:

forming code representations of said multi-element information patterns to be displayed, *each element being represented by a first number of bits;*

converting said code representations into corresponding first multi element information patterns

3

corresponding to images to be displayed, *each element being represented by a second number of bits greater than said first number of bits;*
 converting said first *multi-element* information patterns into second *multi-element* information patterns for directly controlling the tracing of associated image patterns on an image display *by logically combining attribute information encoded in a second number of bits with the bit representation for each element of said second multi-element information*

4

patterns; said second information patterns having associated image characteristics different from those of the respective first information patterns; and
 storing said second information patterns in *contiguous address memory locations* of a display buffer capable of directly controlling the information of images on an image display.

* * * * *

15

20

25

30

35

40

45

50

55

60

65