

[54] METHOD AND APPARATUS FOR CONTROLLING AN INTERNAL COMBUSTION ENGINE, PARTICULARLY THE STARTING UP OF THE ENGINE

[75] Inventors: Hiroastu Tokuda, Katsuta; Toshio Furuhashi, Mito, both of Japan

[73] Assignee: Hitachi, Ltd., Tokyo, Japan

[21] Appl. No.: 505,364

[22] Filed: Jun. 16, 1983

4,205,376 5/1980 Yoshida 364/431.11
 4,214,306 7/1980 Kobayashi 364/431.08
 4,255,789 3/1981 Hartford et al. 364/431.06

Primary Examiner—Felix D. Gruber
 Attorney, Agent, or Firm—Antonelli, Terry & Wands

[57] ABSTRACT

A method and an apparatus for controlling an internal combustion engine employs a scheme whereby the operating conditions of the engine for normal operation are detected. Desired set values representative of the desired operating conditions of the engine are calculated on the basis of the detected operating conditions, and the desired set values are set in respective reference registers. The contents of one of instantaneous registers for storing instantaneous operating conditions of the engine respectively corresponding to the desired set values are successively compared with the desired set value stored in the corresponding one of the reference registers and a control signal is supplied in accordance with the result of each comparison to control the operation of the engine so that optimal operation of the engine may be performed.

Prior to the starting of the engine, a preset scenario or procedure is carried out in response to the turn on of the key switch. According to this preset scenario or procedure, the desired initial values for the operating conditions of the engine at the starting instant are set in the respective reference registers and then the operation for successively comparing one of the desired initial values with the corresponding one of instantaneous operating conditions of the engine is begun.

Related U.S. Patent Documents

Reissue of:

[64] Patent No.: 4,274,141
 Issued: Jun. 16, 1981
 Appl. No.: 952,532
 Filed: Oct. 18, 1978

[30] Foreign Application Priority Data

Oct. 19, 1977 [JP] Japan 52-125979

[51] Int. Cl.⁴ F02D 41/24; F02P 5/04; G05B 15/02

[52] U.S. Cl. 364/431.06; 123/417; 123/480; 123/486; 364/431.05

[58] Field of Search 364/431.10, 431.05, 364/431.06; 123/417, 425, 480, 486

[56] References Cited

U.S. PATENT DOCUMENTS

3,816,717 6/1974 Yoshida et al. 364/431.05
 3,969,614 7/1976 Moyer et al. 364/431.06
 4,009,699 3/1977 Hetzler et al. 123/486 X
 4,099,495 7/1978 Kiencke et al. 364/442

76 Claims, 57 Drawing Figures

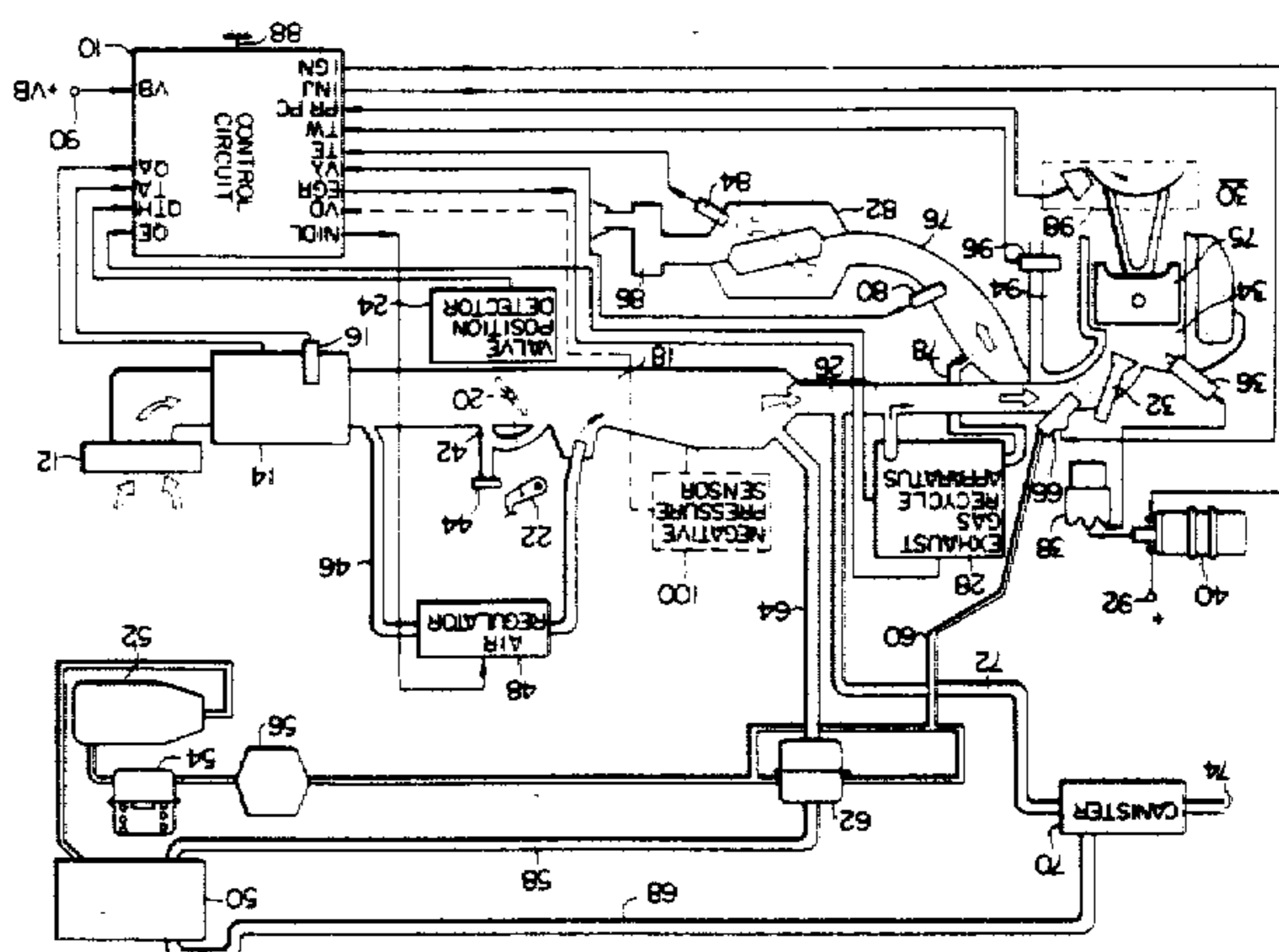
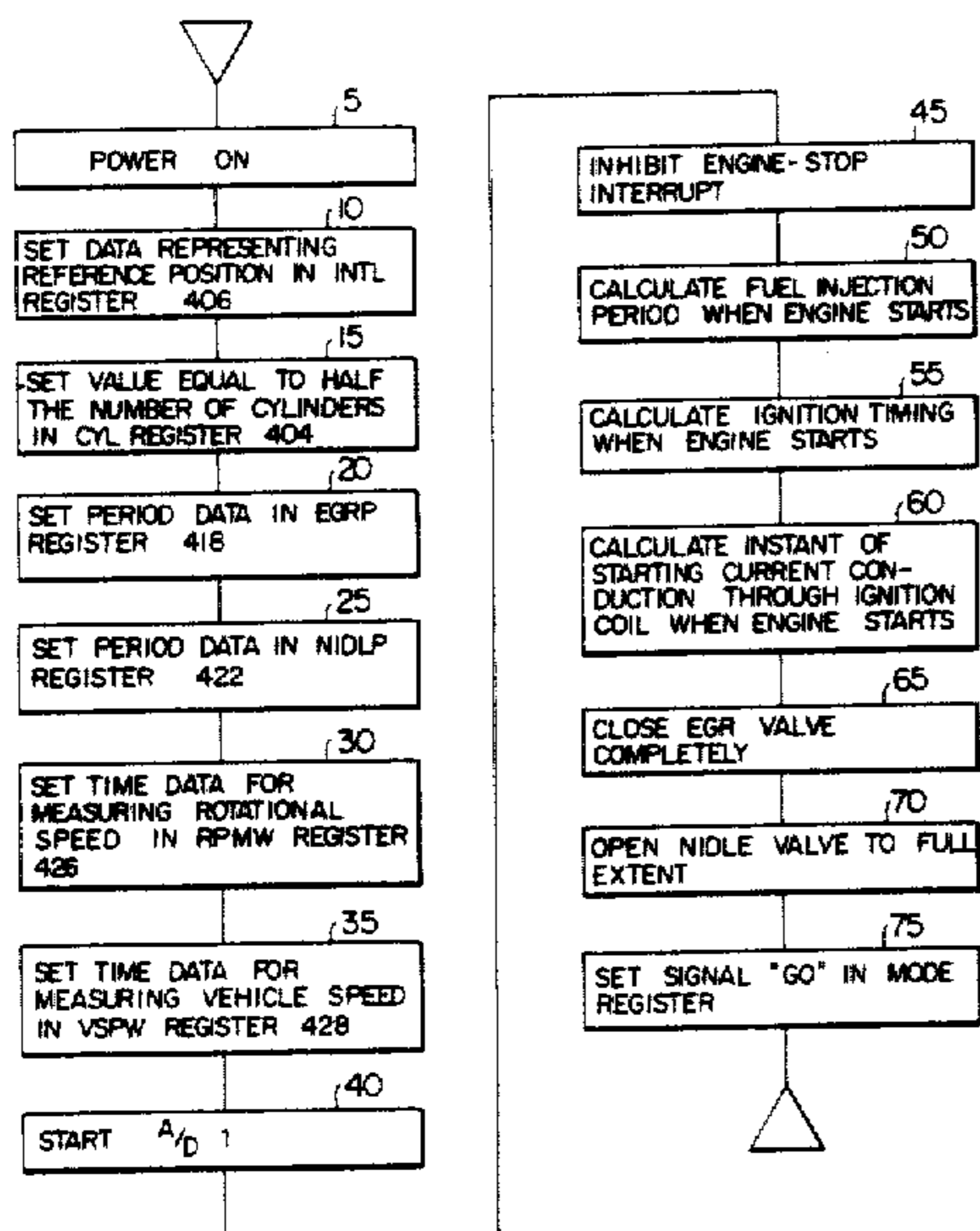

FIG. 1

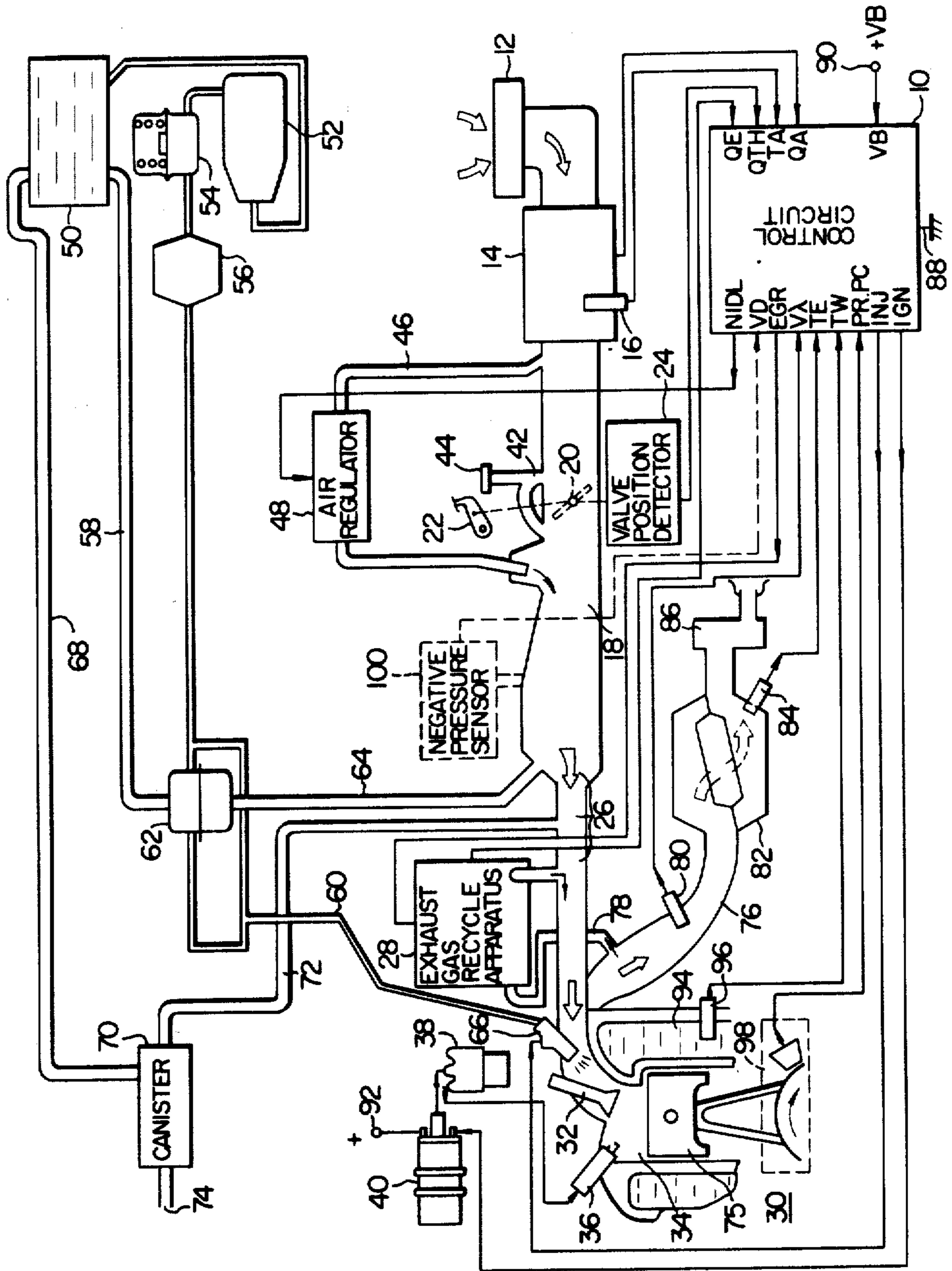
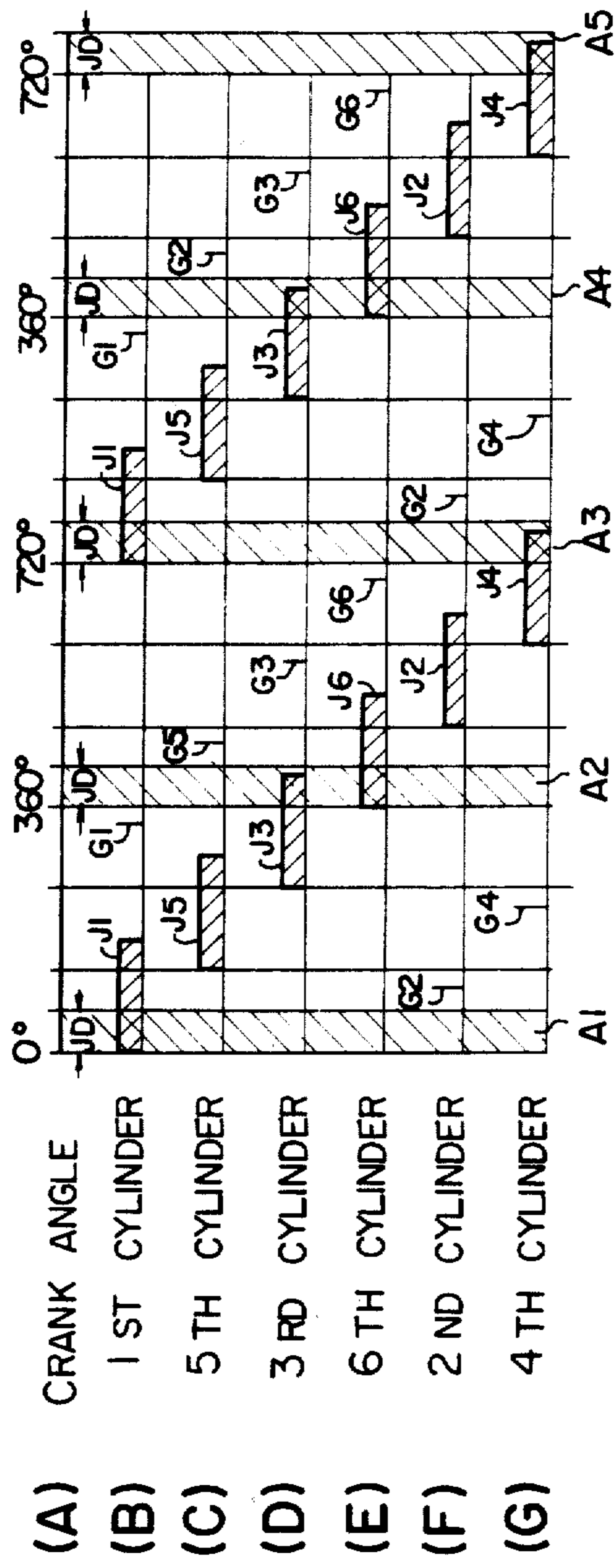

FIG. 2



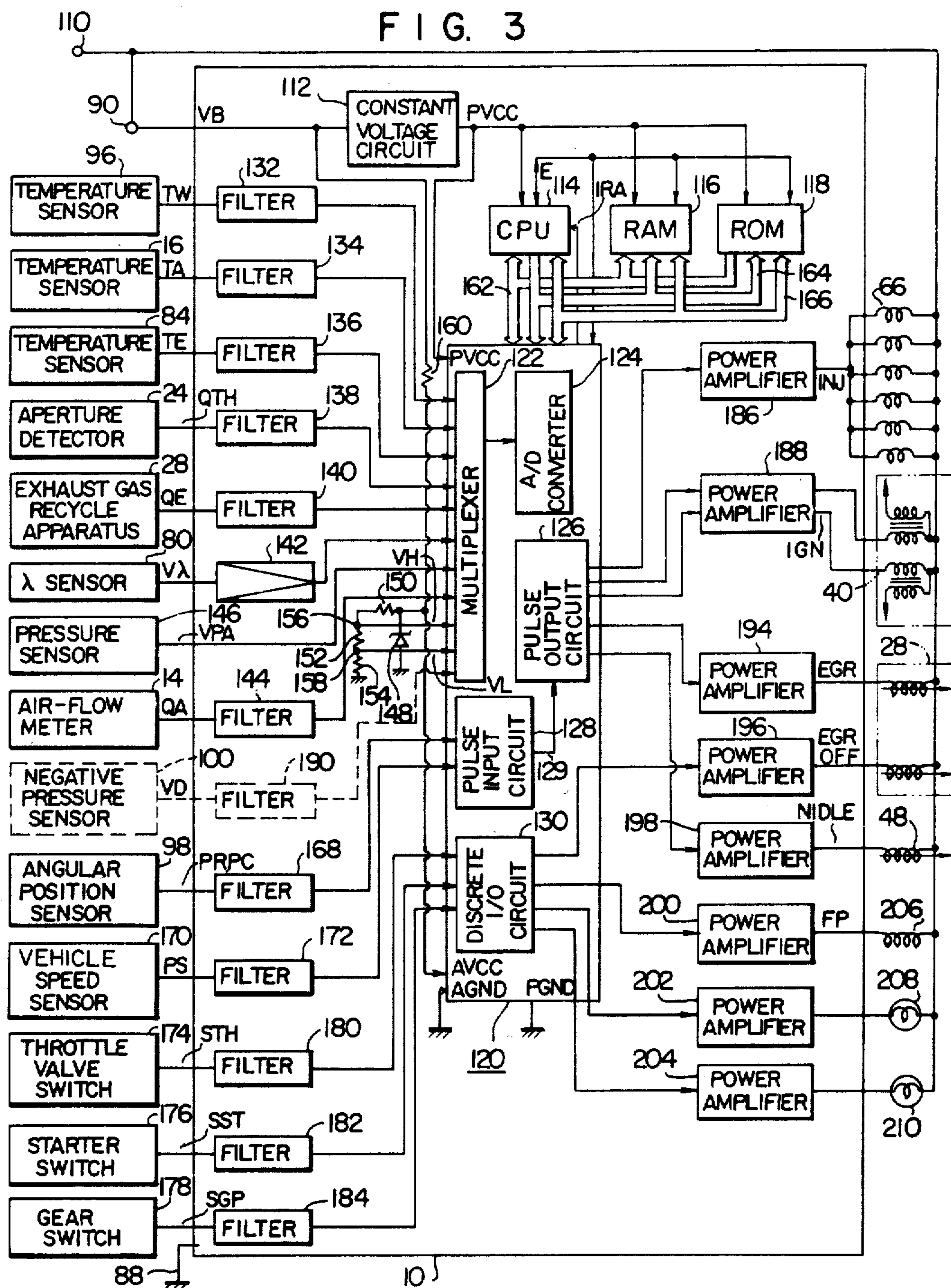

FIG. 4

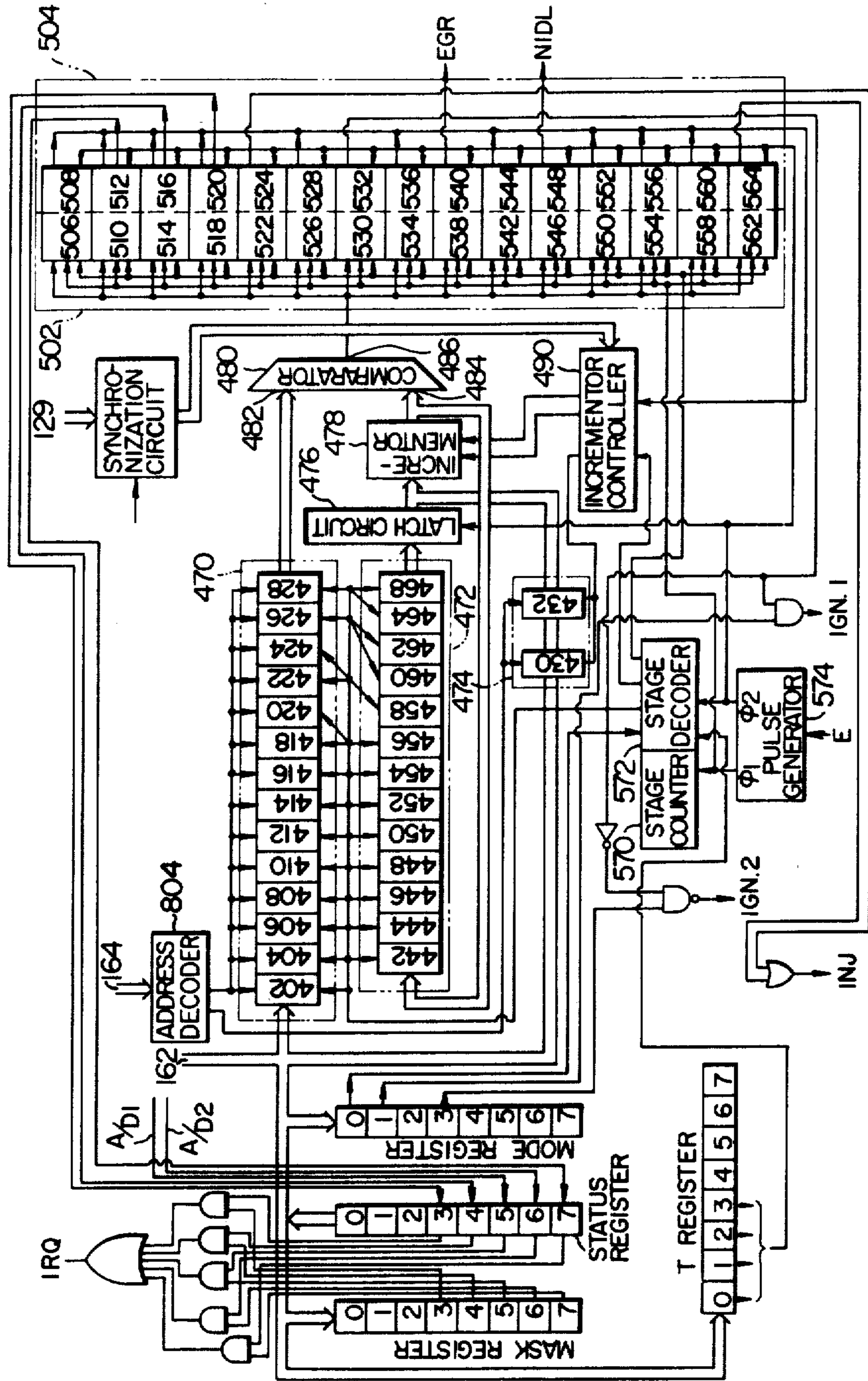

FIG. 5

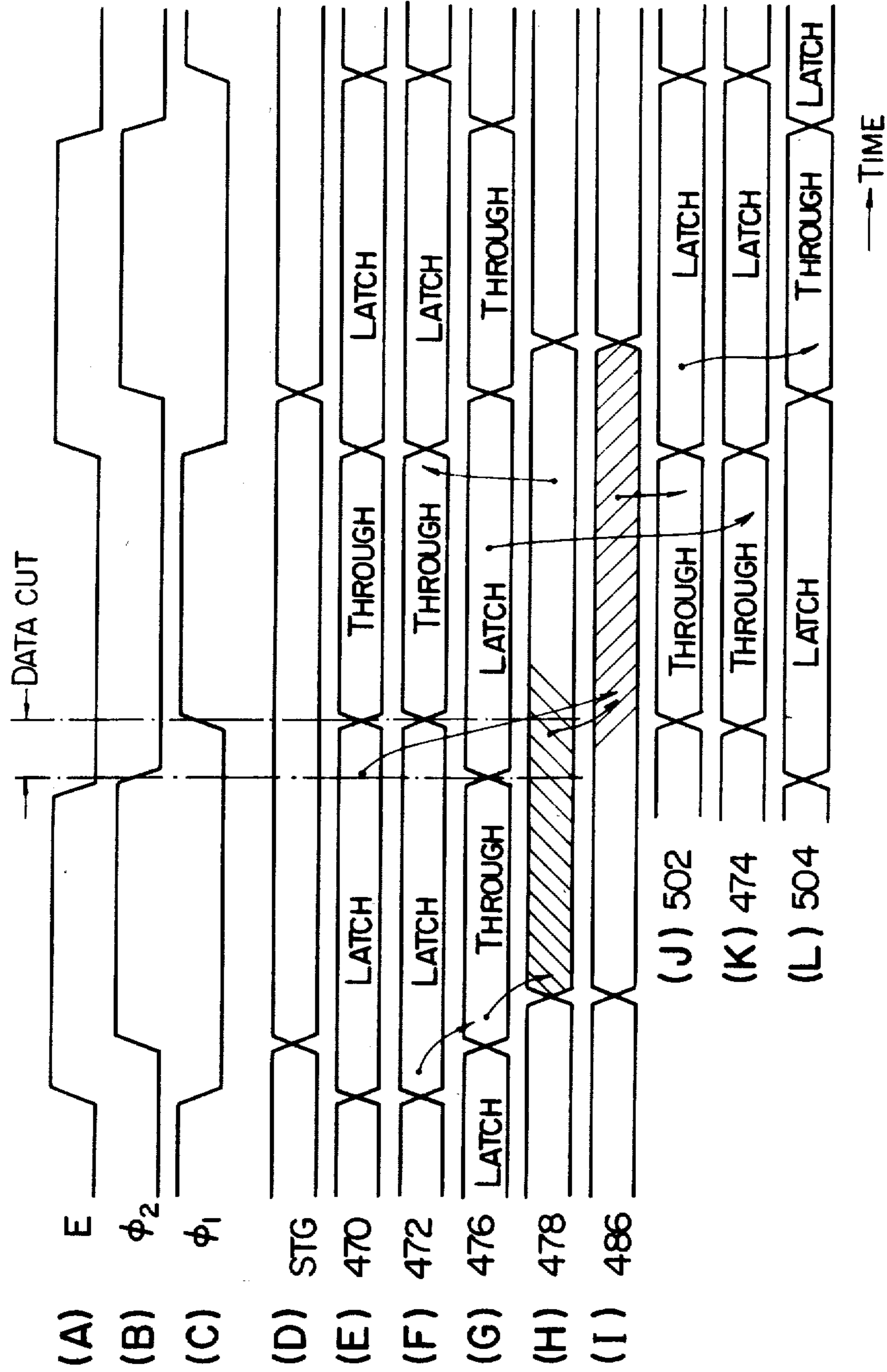

FIG. 6

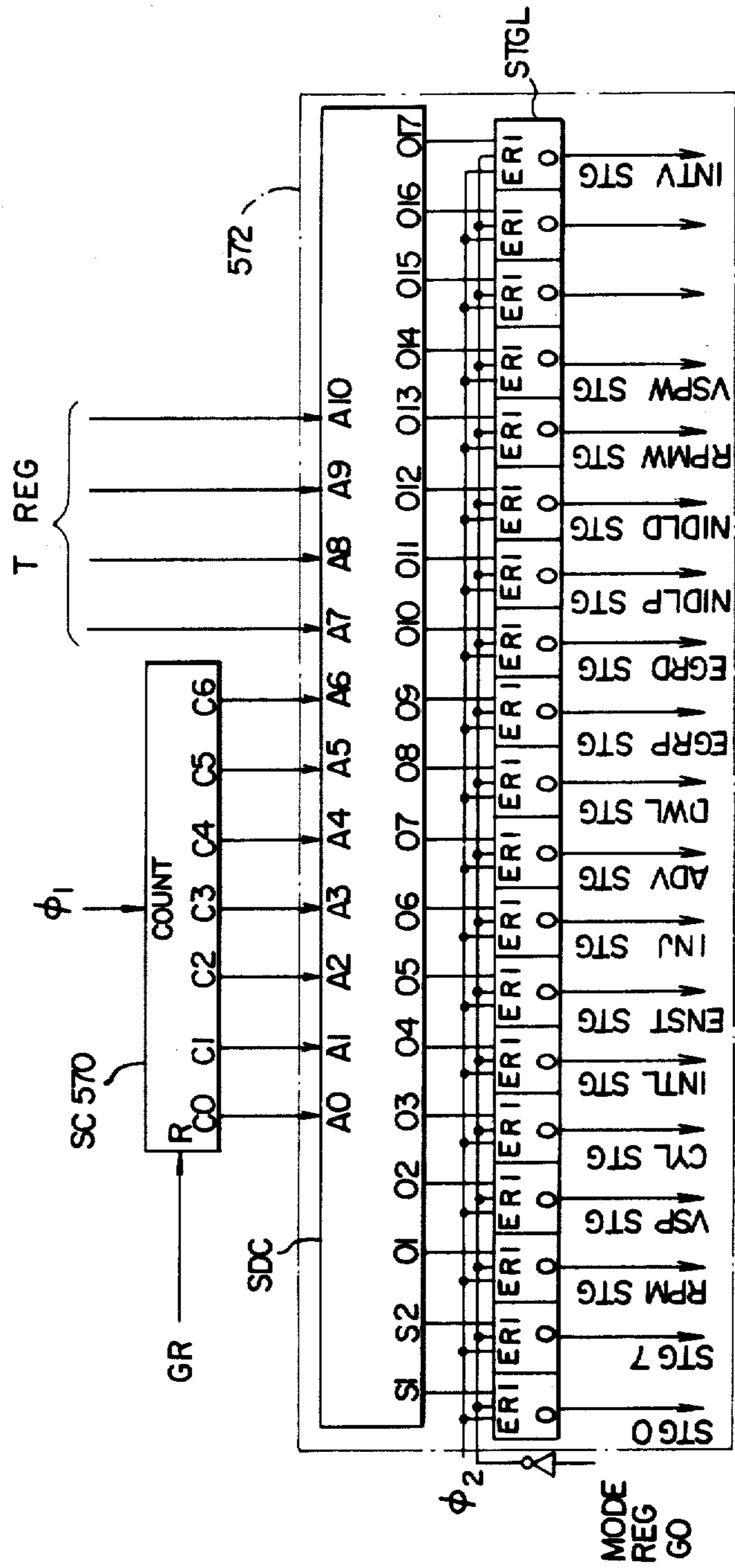

FIG. 7

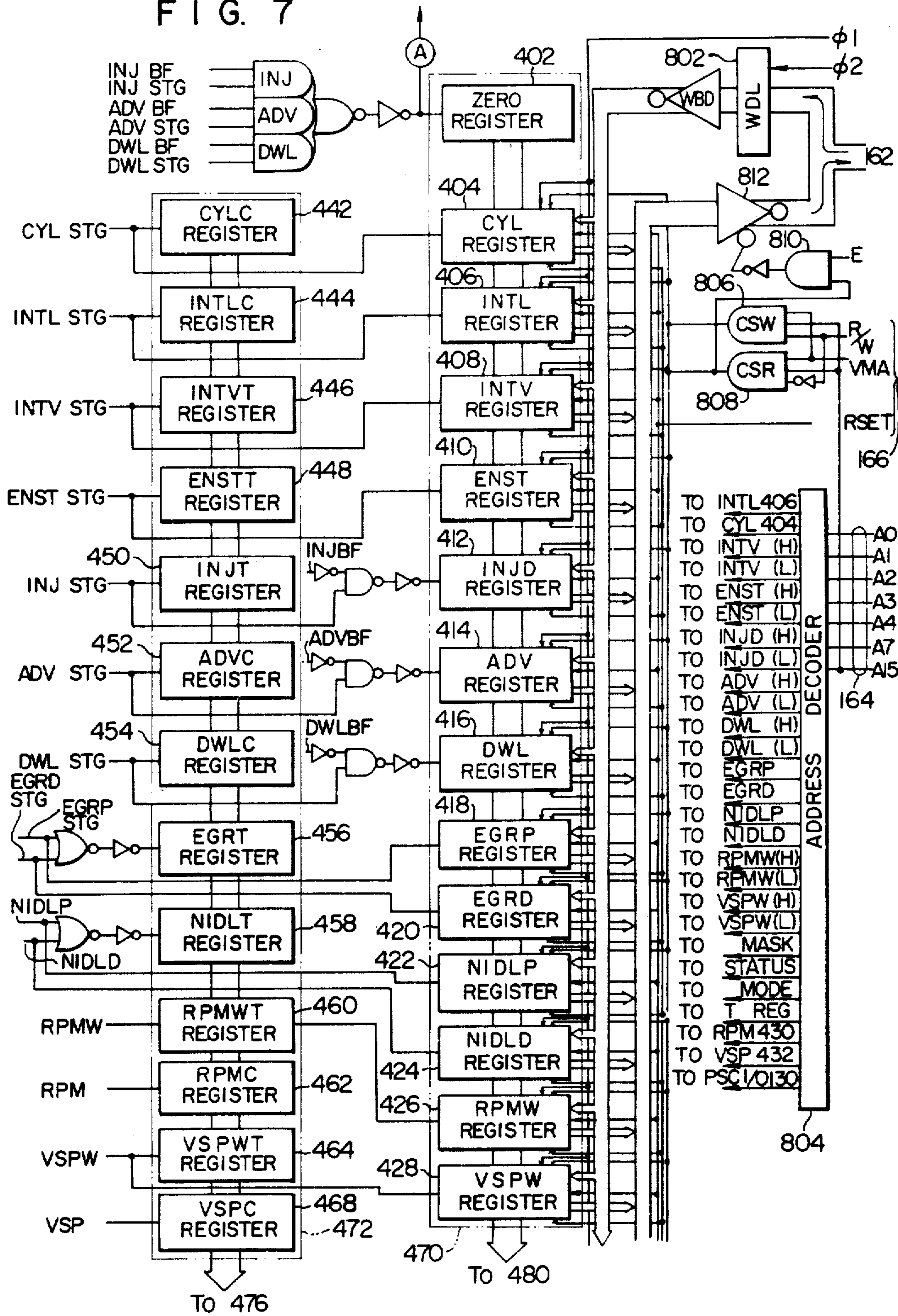

FIG. 8

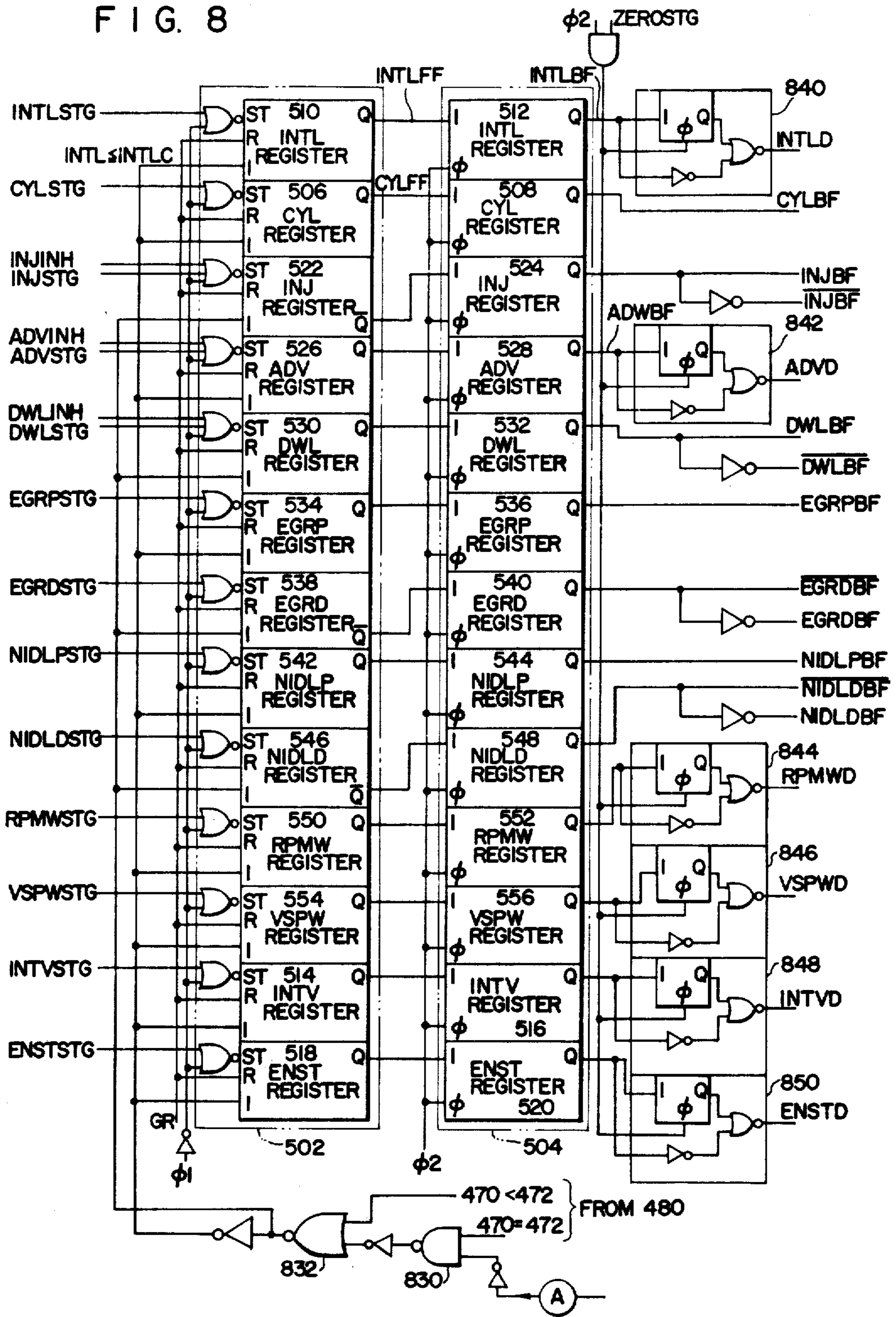

FIG. 9

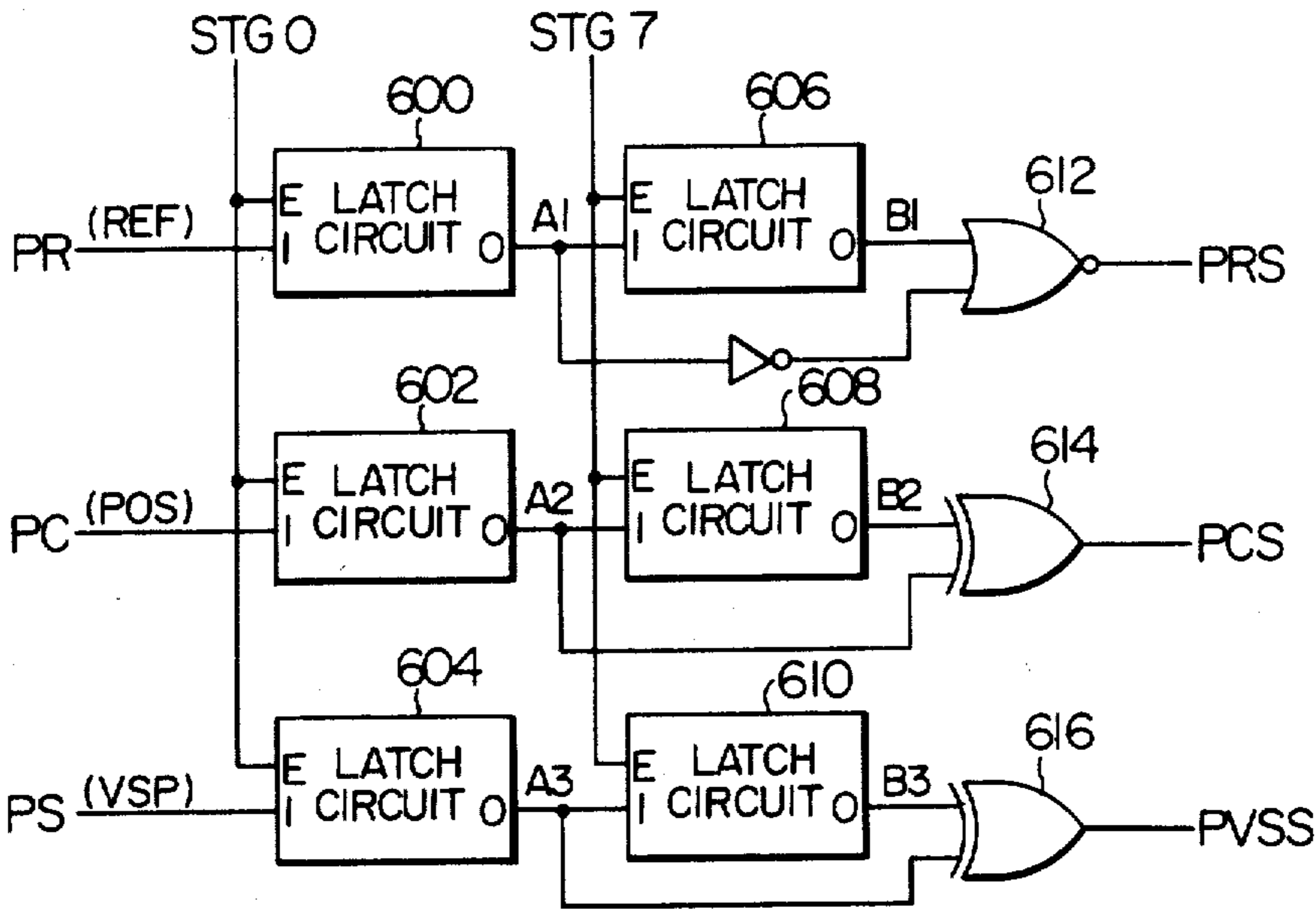

FIG. 10

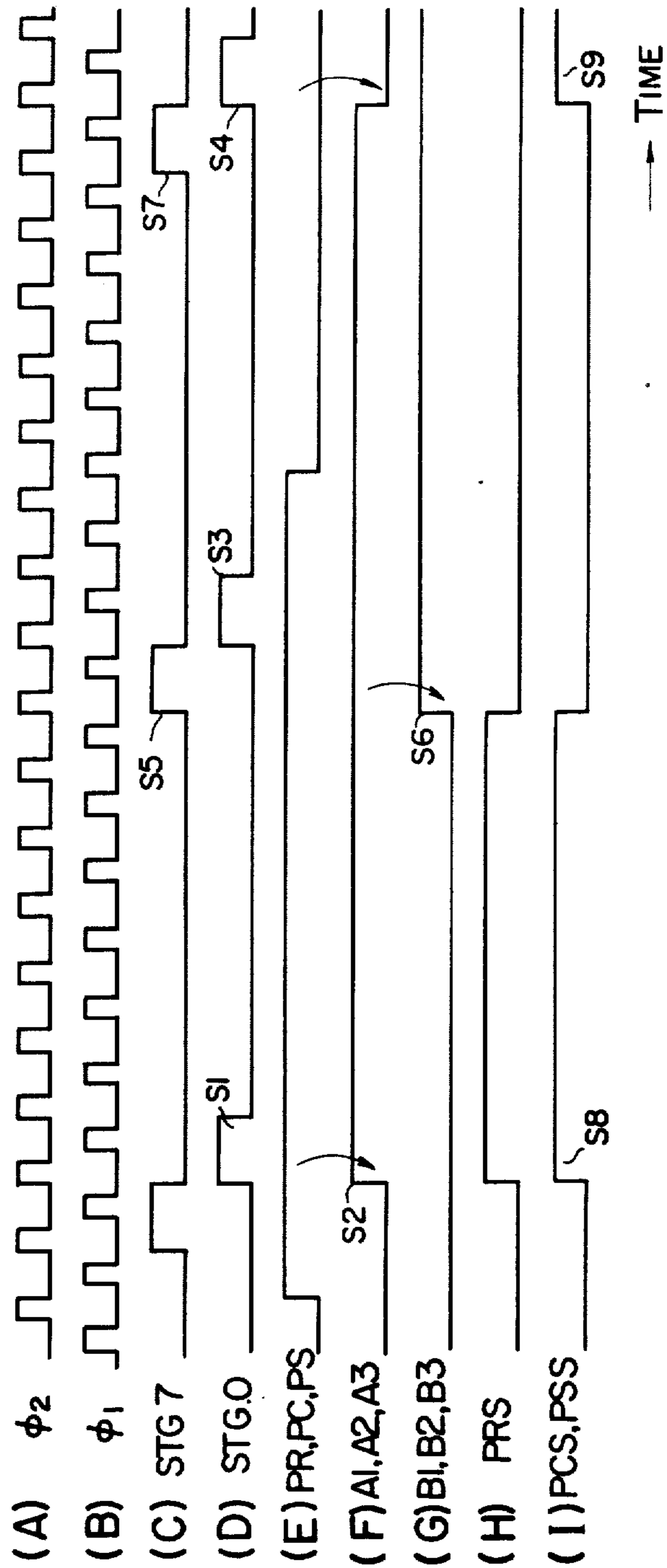
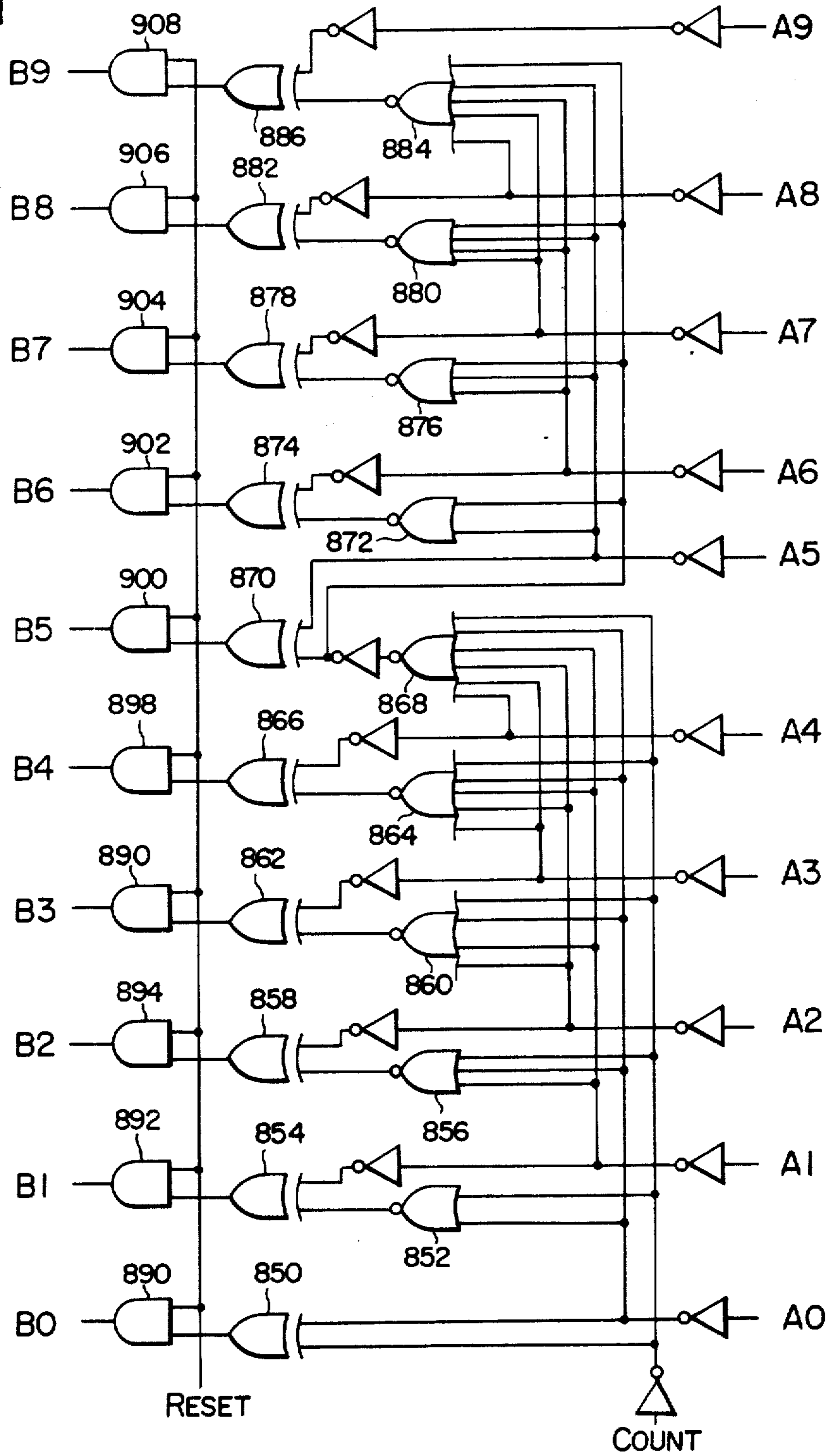

FIG. 11



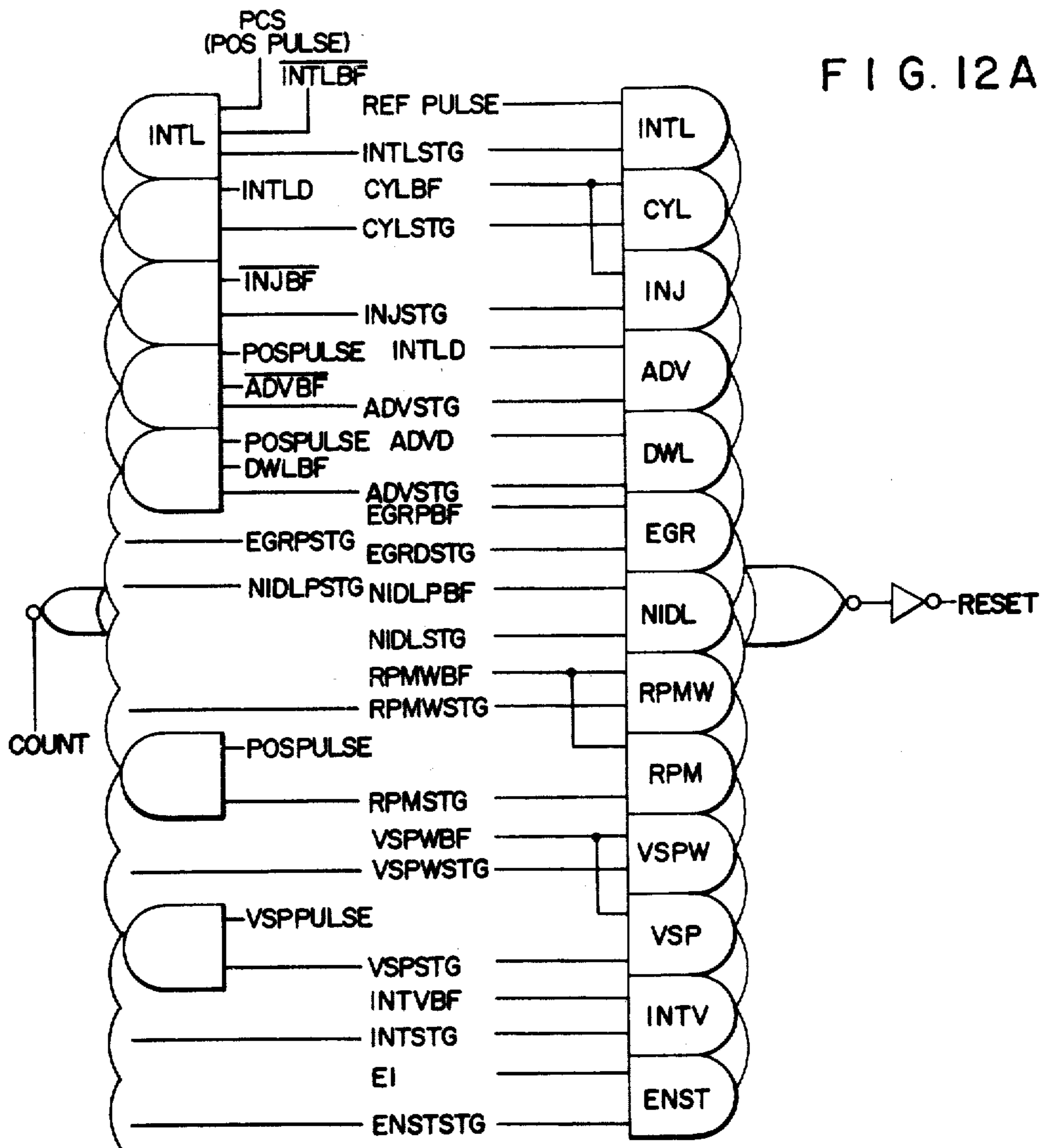

FIG. 12A

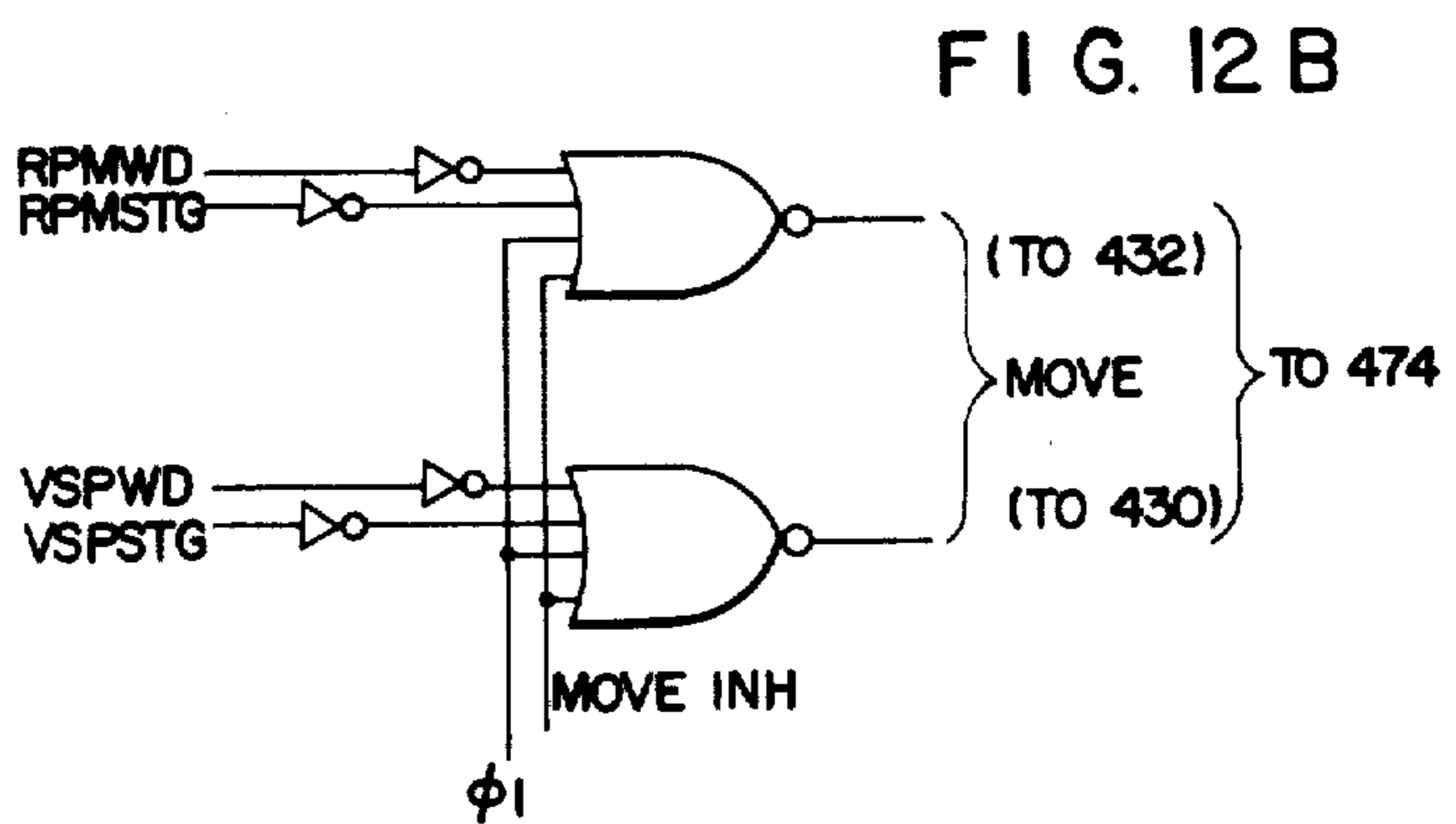

FIG. 12B

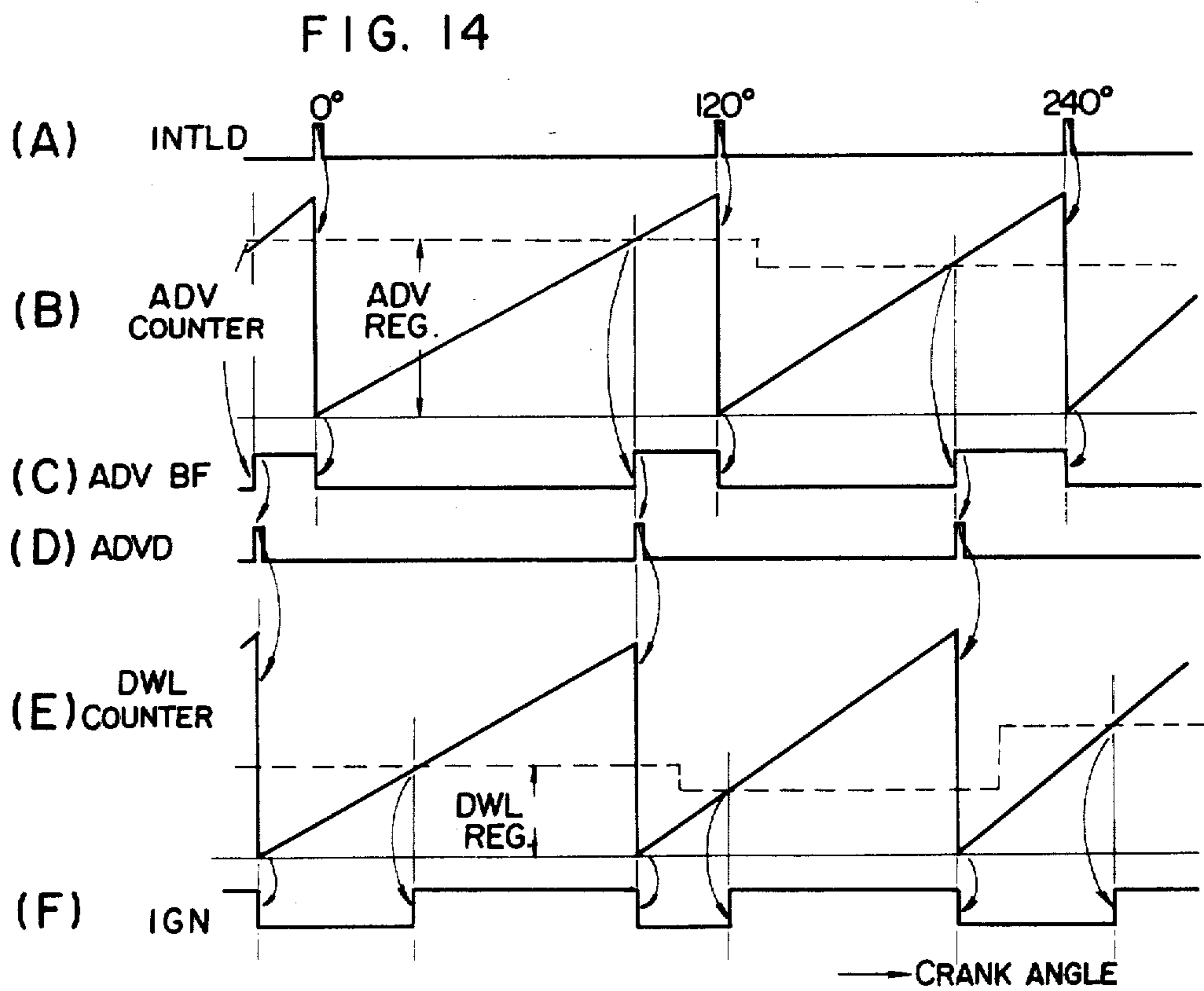
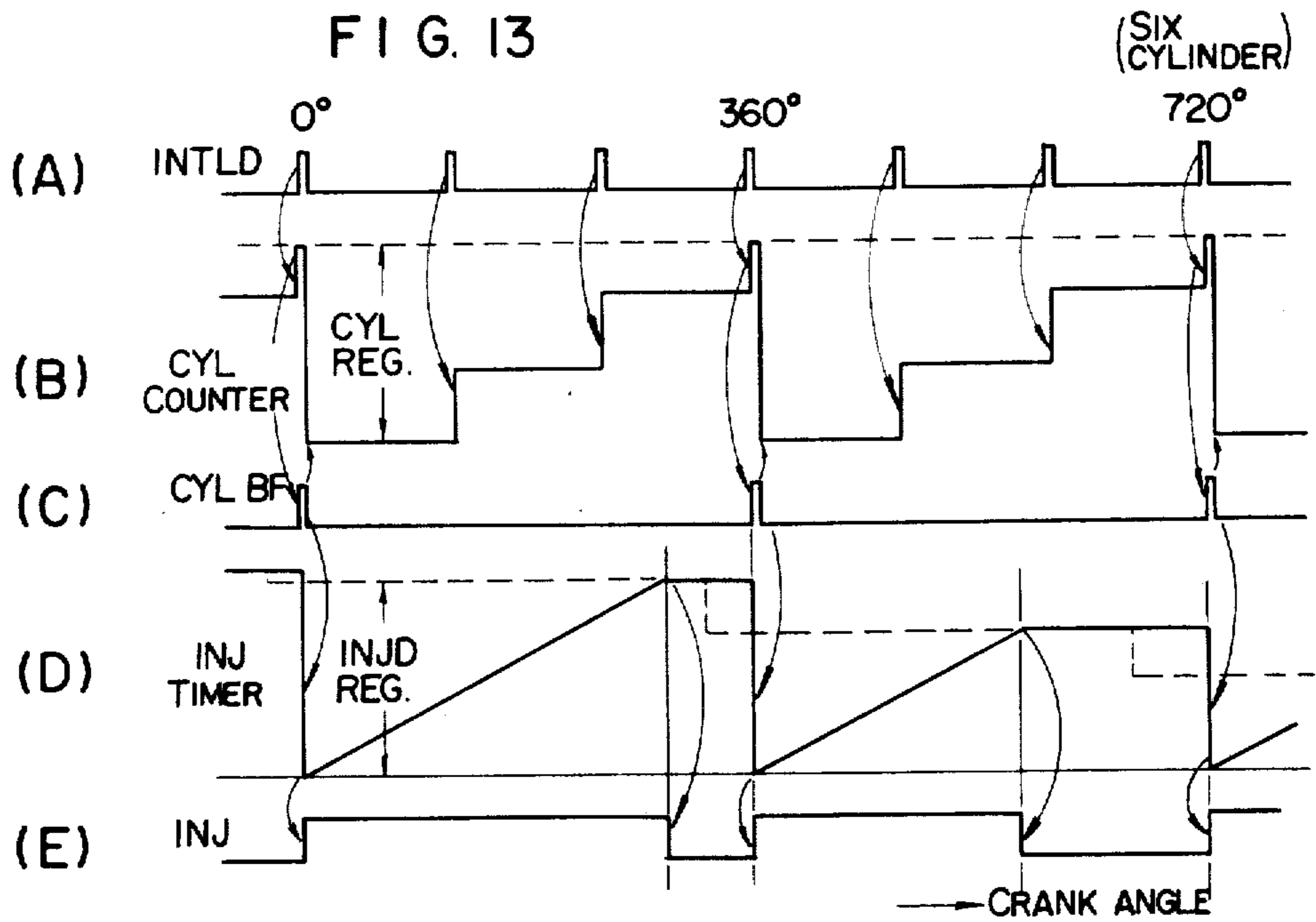

FIG. 15

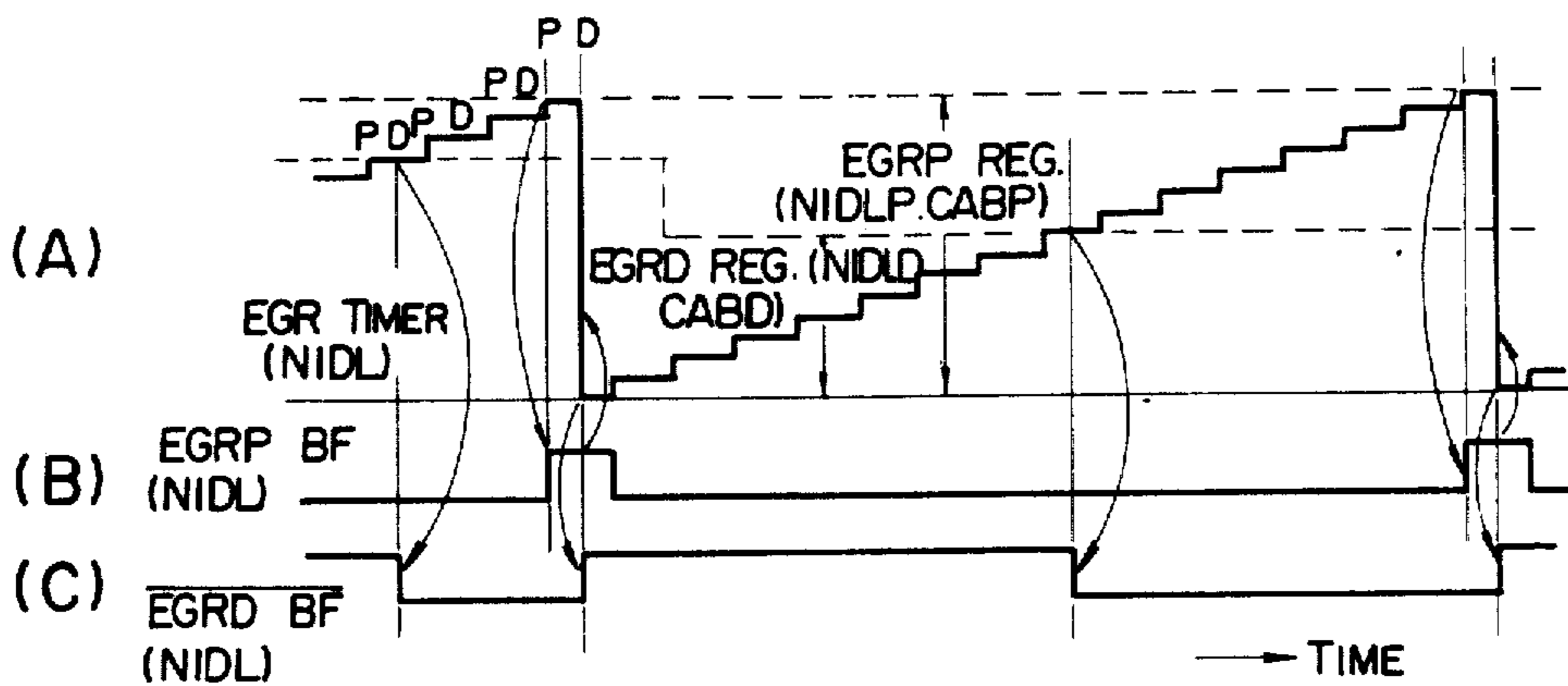

FIG. 16

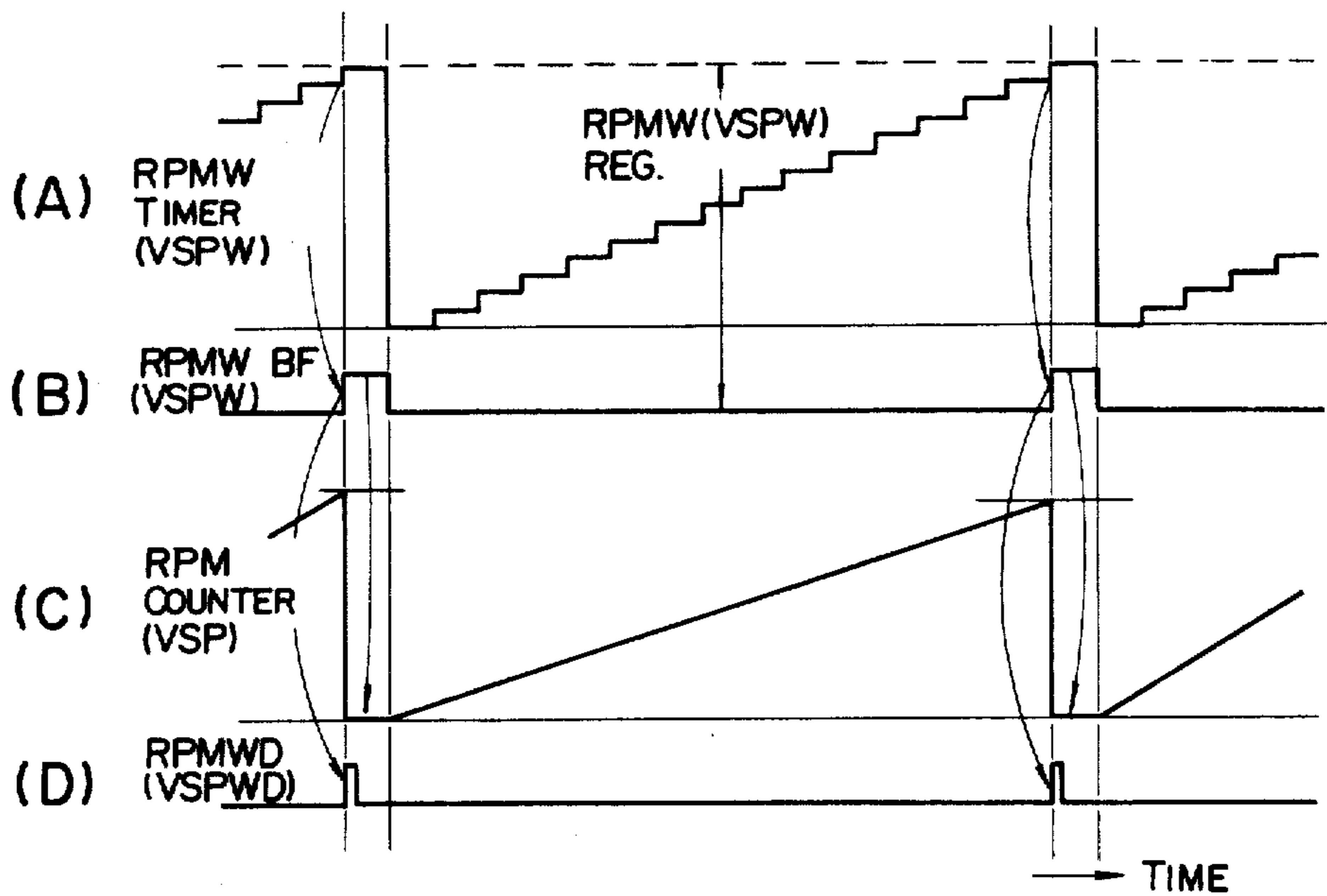
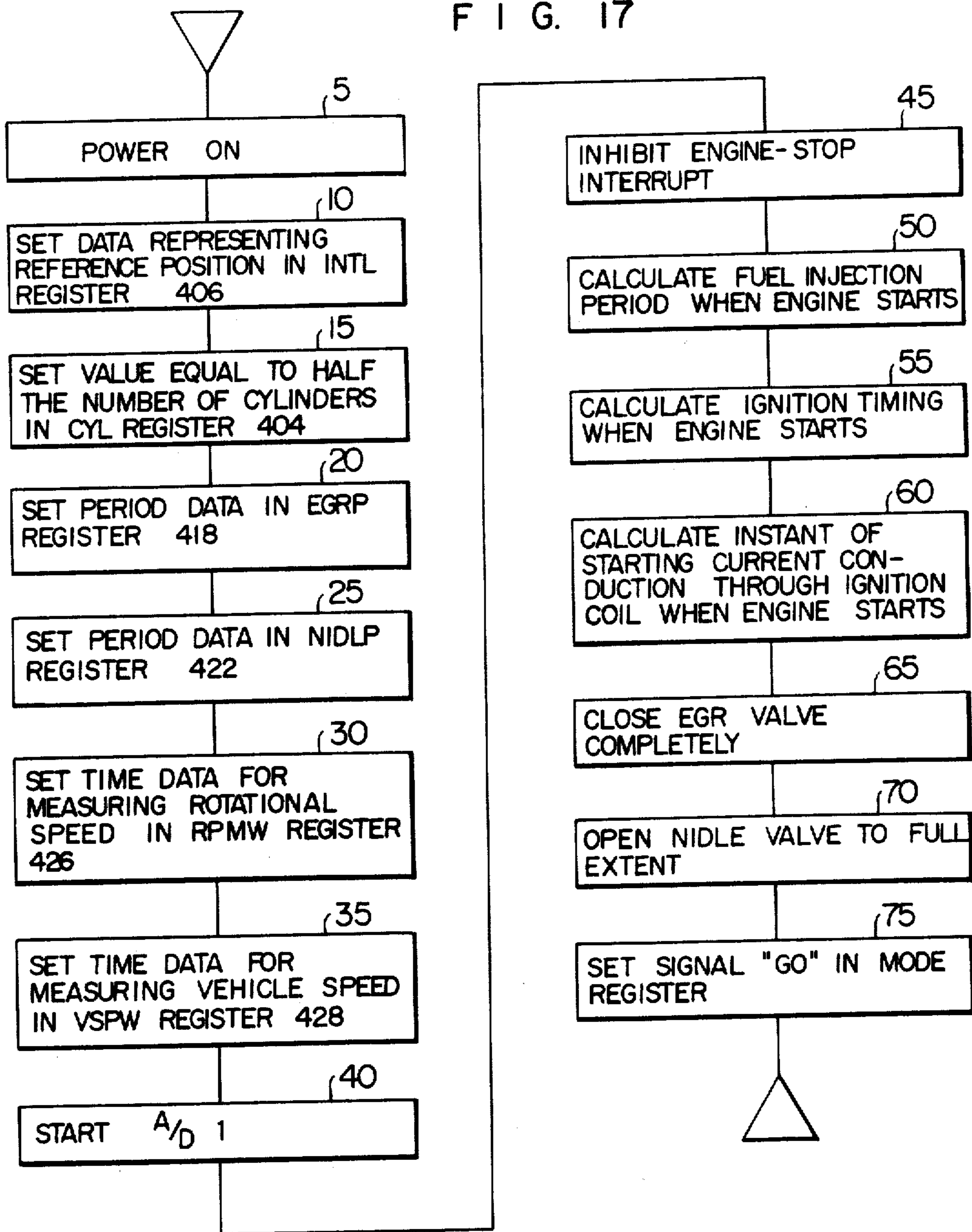

FIG. 17



**METHOD AND APPARATUS FOR CONTROLLING
AN INTERNAL COMBUSTION ENGINE,
PARTICULARLY THE STARTING UP OF THE
ENGINE**

Matter enclosed in heavy brackets [] appears in the original patent but forms no part of this reissue specification; matter printed in italics indicates the additions made by reissue.

**CROSS REFERENCE TO RELATED
APPLICATIONS**

The present application relates to subject matter disclosed in the following applications:

U.S. Ser. No. 943,930; filed: Sept. 20, 1978; Hiroastu Tokuda et al, *now U.S. Pat. No. 4,267,601.*

U.S. Ser. No. 951,509; filed: Oct. 16, 1978; Shigeki Morinaga et al, *now abandoned.*

U.S. Ser. No. 952,275; filed: Oct. 18, 1978; Masao Takato et al, *now U.S. Pat. No. 4,280,189.*

U.S. Ser. No. 952,276; filed: Oct. 18, 1978; Hiroastu Tokuda et al, *now U.S. Pat. No. 4,277,892.*

U.S. Ser. No. 952,279; filed: Oct. 18, 1978; Hiroastu Tokuda et al, *now U.S. Pat. No. 4,309,759.*

U.S. Ser. No. 952,326; filed: Oct. 18, 1978; Masumi Imai et al, *now U.S. Pat. No. 4,310,889.*

U.S. Ser. No. 952,531; filed: Oct. 18, 1978; Masumi Imai et al, *now U.S. Pat. No. 4,312,038.*

U.S. Ser. No. 952,533; filed: Oct. 18, 1978; Masumi Imai et al, *now U.S. Pat. No. 4,282,573.*

U.S. Ser. No. 011,845; filed: Feb. 13, 1979; Toshio Furuhashi et al, *now U.S. Pat. No. 4,310,888.*

U.S. Ser. No. 059,029; filed: July 19, 1979; Sanshiro Obara et al, *now U.S. Pat. No. 4,276,602.*

U.S. Ser. No. 060,751; filed: July 26, 1979; Toshio Furuhashi et al, *now U.S. Pat. No. 4,296,722.*

U.S. Ser. No. 064,431; filed: Aug. 7, 1979; Toshio Furuhashi, *now U.S. Pat. No. 4,274,142.*

U.S. Ser. No. 073,085; filed: Sept. 6, 1979; Masumi Imai et al, *now U.S. Pat. No. 4,408,279.*

This invention relates to an electronic control apparatus for controlling an internal combustion engine for an automobile and more particularly to the setting of initial values for the electronic control apparatus before the starting of the engine.

With the continuing demand for automobiles as means of transportation, there have arisen several social problems. Among them are air pollution and consumption of fossil fuels, especially petroleum.

Some measures have been taken to reduce harmful substances in exhaust gases, but this has caused a degradation of the overall efficiency of the internal combustion engine (hereafter referred simply to as engine). For the purpose of preventing a degradation of the operating efficiency of engine and improving measures against exhaust gases, an electronic control apparatus has been employed which enjoys improved control precision. For example, there have been proposed an electronically controlled fuel injection apparatus and an electronically controlled ignition timing apparatus, and most recently an ignition apparatus controlled by a microprocessor.

The conventional trend in such a control apparatus is toward the mere replacement of mechanical control by an electric one and therefore the individual controlled

objects must be provided with the associated electronic control units.

The control of an engine should suppress the harmful components in exhaust gases and operate the engine with a high efficiency. The assembly of the separate electronic control units provided for the controlled objects, e.g. the electronically controlled fuel injection apparatus and the electronically controlled ignition timing apparatus, as described above, has a poor interrelation among the control units so that a close control of the overall control system is impossible. Moreover, such a composite control system must be accompanied by extremely complicated circuits. For example, a circuit for detecting the irregular output of a sensor such as an angular position sensor must be employed.

Moreover, the specification of the control apparatus must be modified depending on the type of engine to which the apparatus is applied, since the values of the separate control units must be adapted to the engine. Therefore, such a control apparatus as described above is not suitable for universal application. Moreover, the initial setting values for the separate control units at the starting of the engine must be chosen to be adaptable for the conditions of the engine, but in the conventional control apparatus the setting values for the separate control units are fixed, so that at the starting of the engine, control is far from optimal.

An object of this invention is to eliminate the above mentioned drawbacks of the conventional apparatus.

According to the electronic control apparatus for an internal combustion engine embodying the present invention, input information indicative of the operating conditions of an engine is used and processed through calculations, and plural registers are provided to hold the respective processed contents and to hold data representing the preset values constantly. The common feature of the data held in these registers is that they are used as reference values for a comparison operation. Therefore, these registers are referred to hereafter as reference registers constituting a reference register group and the data held in the reference registers is referred to as reference data.

On the other hand, plural registers are provided to hold data representing the instantaneous conditions of engine and other mechanisms and these registers are referred to hereafter as instantaneous registers constituting an instantaneous register group.

This electronic control apparatus comprises a reference register group, an instantaneous register group, comparison circuits, an incrementor, an incrementor controller, comparison result holding circuit and a stage counter. According to this electronic control apparatus with the combination of these circuit elements, the stage counter causes the respective stages to be sequentially operated for processing operation in a predetermined order. For the particular processing operation of each stage, desired registers are successively selected from among the reference and instantaneous register groups to send the reference data and the instantaneous data from the selected registers to the associated comparison circuit. The result of the comparison, i.e. the output of the comparison circuit, is held in a comparison result holding circuit.

Concerning the stages of operation, the instantaneous data held in each instantaneous register corresponding to a stage of operation is rewritten according to the actually instantaneous condition of the engine or other

mechanisms. The rewriting operation is controlled by the incrementor and the incrementor controller.

Namely, the incrementor controller determines if the data representing the instantaneous moments or angular positions of a crank shaft (in this specification, the term "crank shaft" is applied to the rotary shaft of not only a reciprocating engine but also a rotary engine) is increased in accordance with the instantaneous conditions of a crank angular position signal and a timing signal to provide a reference unit of time. The incrementor then increases the data by a certain unit in accordance with the result of the determination. In this way, the instantaneous data is renewed instantaneously and the renewed instantaneous data is used for actual comparison.

With this constitution, a complex control can be realized by a relatively simple circuit configuration and the pulse signals received irregularly are detected after they have been synchronized, so that the pulse signals can be accurately detected and therefore the incrementor can be operated exactly.

In this control apparatus, it is necessary to place prescribed reference data for the initial control of the engine in the reference registers before beginning the comparison operation, thereby properly starting the engine.

An object of the present invention is to provide a scheme for controlling the start up of the engine by initiating the comparison operation subsequent to the placing of reference data for the initial control of the various actuators of the engine in response to the turnon of the ignition or power switch.

According to the present invention, initial reference data is delivered from the processor into a set of reference registers in response to the application of the power source to the system, which, effectively, is switched over by the turning of the key in the ignition switch. Thereafter, an instruction signal for beginning the start of the comparison operation with respect to the contents of the reference registers and the contents of the instantaneous registers is delivered from the microprocessor. This starts the comparison operation so that the subsequent outputs of the comparison operation through the comparator may be applied to the actuators for controlling the engine.

The above and other objects, features and advantages of the present invention will be more clear from the following description with reference to the accompanying drawings, in which:

FIG. 1 shows an arrangement plan or sensors and actuators in an embodiment of an electronic control apparatus of the engine;

FIG. 2 (A-G) is a diagram for explaining the operation of the circuits shown in FIG. 1;

FIG. 3 shows the detail of the control circuit shown in FIG. 1;

FIG. 4 shows a partial detail of the input/output circuit shown in FIG. 3;

FIG. 5 (A-L) is a diagram for explaining the operation of the circuit shown in FIG. 4;

FIG. 6 shows the detail of the stage counter shown in FIG. 4;

FIG. 7 shows in detail concrete examples of the reference and the instantaneous register groups shown in FIG. 4;

FIG. 8 shows in detail concrete examples of the first and the second comparison output register groups 502 and 504;

FIG. 9 shows a detail a synchronizing circuit;

FIG. 10 (A-I) is a diagram for explaining the operation of the circuit shown in FIG. 9;

FIG. 11 shows in detail a concrete example of the incrementor 478 shown in FIG. 4;

FIG. 12A and 12B show in detail an incrementor controller;

FIG. 13 (A-E) shows the waveforms useful in explaining the processing of the fuel injection signal;

FIG. 14 (A-F) shows the waveforms useful in explaining the ignition timing control;

FIG. 15 (A-C) shows the waveforms useful in explaining the processing by EGR or NIDL;

FIG. 16 (A-D) shows the signal waveform useful in explaining the detection of the rotational speed RPM of engine or the speed VSP of vehicle; and

FIG. 17 illustrates a flow chart of the operation of the setting the initial values for the electronic control apparatus before the starting of the engine according to this invention.

The electronic engine control apparatus will now be described by way of embodiment with the aid of attached drawings. FIG. 1 shows the main structure of an electronic engine control apparatus. Air sucked or drawn in through an air cleaner 12 is passed through an air-flow meter 14 to measure the flow rate thereof and the air-flow meter 14 delivers an output QA indicating the flow rate of air to a control circuit 10. A temperature sensor 16 is provided in the air-flow meter 14 so as to detect the temperature of the sucked air and the output TA of the sensor 16, indicating the temperature of the sucked air, is also supplied to the control circuit 10.

The air flowing through the air-flow meter 14 is further passed through a throttle chamber 18, an intake manifold 26 and a suction or intake valve 32 to the combustion chamber 34 of an engine 30. The quantity of air drawn into the combustion chamber 34 is controlled by changing the aperture or opening of a throttle valve 20 provided in the throttle chamber 18 and interlocked with an accelerator pedal 22. The aperture of the throttle valve 20 is detected by detecting the valve position of the throttle valve 20 by a throttle valve position detector 24 and the signal QTH representing the valve position of the throttle valve 20 is supplied from the throttle valve position detector 24 to the control circuit 10.

The throttle chamber 18 is provided with a bypass 42 for idling the engine and an idle adjust screw 44 for adjusting the flow of air through the bypass 42. When the throttle valve 20 is completely closed, the engine is operated in the idling condition. The sucked air past the air-flow meter flows via the bypass 42 and drawn into the combustion chamber 34. Accordingly, the flow of the air sucked in under the idling condition is changed by adjusting the idle adjust screw 44. The energy created in the combustion chamber 34 is determined substantially depending on the flow rate of the air drawn through the bypass 42 so that the rotational speed of the engine under the idling conditions can be adjusted to an optimal one by controlling the flow rate of air inhaled into the combustion chamber by adjusting the idle adjust screw 44.

The throttle chamber 18 is also provided with another bypass 46 and an air regulator 48. The air regulator 48 controls the flow rate of the air through the bypass 46 in accordance with the output signal NIDL of the control circuit 10, so as to control the rotational speed of the engine during the warming-up operation

and to properly supply air into the combustion chamber at a sudden change, especially a sudden closing, in the valve position of the throttle valve 20. The air regulator 48 can also change the flow rate of air during the idling operation.

Next, the fuel supply system will be described. Fuel stored in a fuel tank 50 is sucked out to a fuel damper 54 by means of a fuel pump 52. The fuel damper 54 absorbs the pressure undulation of the fuel supplied from the fuel pump 52 so that fuel having a constant pressure can be supplied through a fuel filter 56 to a fuel pressure regulator 62. The fuel past the fuel pressure regulator 62 is sent by pressure to a fuel injector 66 through a fuel pipe 60 and the output INJ of the control circuit 10 causes the fuel injector 66 to be actuated to inject the fuel into the intake manifold 26.

The quantity of the fuel injected by the fuel injector 66 is determined by the period during which the fuel injector 66 is opened and by the difference between the pressure of the fuel supplied to the injector and the pressure in the intake manifold 26 into which the pressurized fuel is injected. It is however preferable that the quantity of the injected fuel should depend only on the period for which the injector is opened and which is determined by the signal supplied from the control circuit 10. Accordingly, the pressure of the fuel supplied by the fuel pressure regulator 62 to the fuel injector 66 is controlled in such a manner that the difference between the pressure of the fuel supplied to the fuel injector 66 and the pressure in the intake manifold 26 is always kept constant in any driving condition. The pressure in the intake manifold 26 is applied to the fuel pressure regulator 62 through a pressure conducting pipe 64. When the pressure of the fuel in the fuel pipe 60 exceeds the pressure upon the regulator 62 by a predetermined level, the fuel pipe 60 communicates with a fuel return pipe 58 so that the excessive fuel corresponding to the excessive pressure is returned through the fuel return pipe 58 to the fuel tank 50. Thus, the difference between the pressure of the fuel in the fuel pipe 60 and the pressure in the intake manifold 26 is kept always constant.

The fuel tank 50 is provided with a pipe 68 connected to a canister 70 provided for the suction of vaporized fuel or fuel gas. When the engine is operating, air is sucked in through an open air inlet 74 to send the fuel-gas into the intake manifold 26 and therefore into the engine 30 via a pipe 72. In the case of stopped engine, the fuel gas is exhausted through active carbon filled in the canister 70.

As described above, the fuel is injected by the fuel injector 66, the suction valve 32 is opened in synchronism with the motion of a piston 75, and a mixture gas of air and fuel is sucked into the combustion chamber 34. The mixture gas is compressed and fired by the spark generated by an ignition plug 36 so that the energy created through the combustion of the mixture gas is converted to mechanical energy.

The exhaust gas produced as a result of the combustion of the mixture gas is discharged into the open air through an exhaust valve (not shown), an exhaust pipe 76, a catalytic converter 82 and a muffler 86. The exhaust pipe 76 is provided with an exhaust gas recycle pipe 78 (hereafter referred to as an EGR pipe), through which a part of the exhaust gas is fed into the intake manifold 26, that is, the part of the exhaust gas is circulated to the suction side of the engine. The quantity of the circulated exhaust gas is determined depending on

the aperture of the valve of an exhaust gas recycle apparatus 28. The aperture is controlled by the output EGR of the control circuit 10 and the valve position of the apparatus 28 is converted to an electric signal QE to be supplied as an input to the control circuit 10.

A λ sensor 80 is provided in the exhaust pipe 78 to detect the fuel-air mixture ratio of the mixture gas sucked into the combustion chamber 34. An oxygen sensor (O_2 sensor) is usually used as the λ sensor 80 and detects the concentration of oxygen contained in the exhaust gas so as to generate a voltage V_λ corresponding to the concentration of the oxygen contained in the exhaust gas. The output V_λ sensor 80 is supplied to the control circuit 10. The catalytic converter 82 is provided with a temperature sensor 84 for detecting the temperature of the exhaust gas in the converter 82 and the output TE of the sensor 84 corresponding to the temperature of the exhaust gas in the converter 84 is supplied to the control circuit 10.

The control circuit 10 has a negative power source terminal 88 and a positive power source terminal 90. The control circuit 10 supplies the signal IGN, for causing the ignition plug 36 to spark, to the primary winding of an ignition coil 40. As a result, a high voltage is induced in the secondary winding of the ignition coil 40 and supplied through a distributor 38 to the ignition plug 36 so that the plug 36 fires to cause the combustion of the mixture gas in the combustion chamber 34. The mechanism of the firing of the ignition plug 36 will be further detailed. The ignition coil 40 has a positive power source terminal 92 and the control circuit 10 also has a power transistor for controlling the primary current through the primary winding of the ignition coil 40. The series circuit of the primary winding the ignition coil 40 and the power transistor is connected between the positive power source terminal 92 of the ignition coil 40 and the negative power source terminal 88 of the control circuit 10. When the power transistor is conducting, electromagnetic energy is stored in the ignition coil 40 and when the power transistor is cut off, the stored electromagnetic energy is released as a high voltage to the ignition plug 36.

The engine 30 is provided with a temperature sensor 96 for detecting the temperature of the water 94 as coolant in the water jacket and the temperature sensor 96 delivers to the control circuit 10 a signal TW corresponding to the temperature of the water 94. The engine 30 is further provided with an angular position sensor 98 for detecting the angular position of the rotary shaft of the engine and the sensor 98 generates a reference signal PR in synchronism with the rotation of the engine, e.g. every 120° of the rotation, and an angular position signal each time the engine rotates through a constant, predetermined angle (e.g. 0.5°). The reference signal PR and the angular position signal PC are both supplied to the control circuit 10.

In the system shown in FIG. 1, the air-flow meter 14 may be replaced by a negative pressure sensor. Such a negative pressure sensor 100 is depicted by dashed line and the negative pressure sensor 100 will supply to the control circuit 10 a voltage VD corresponding to the negative pressure in the intake manifold 26. A semiconductor negative pressure sensor is practically used as such a negative pressure sensor 100. One side of the silicon chip of the semiconductor is acted on by the boost pressure of the intake manifold while the atmospheric or a constant pressure is exerted on the other side of the chip. The constant pressure may be a vacuum

as the case may be. With this construction, a voltage VD corresponding to the pressure in the intake manifold is generated, which is to be supplied to the control circuit 10.

FIG. 2 illustrates the relationships between the firing timing and the crank angular position and between the fuel injection timing and the crank angular position, where a six-cylinder engine is used. In FIG. 2, diagram A represents the crank angular position and indicates that a reference signal PR is delivered by the angular position sensor 98 every 120° of the crank angle. The reference signal PR is therefore supplied to the control circuit 10 at 0°, 120°, 240°, 360°, 480°, 600°, 720° etc. of the angular position of the crank shaft.

Diagrams B, C, D, E, F and G correspond respectively to the 1st cylinder, the 5th cylinder, the 3rd cylinder, the 6th cylinder, the 2nd cylinder and the 4th cylinder. J₁-J₆ designate respectively the periods for which the suction valves of the corresponding cylinders are open. The periods are shifted by 120° of crank angle from one another. The beginning and the durations of the periods at which the suction valve is open are generally as shown in FIG. 2 though somewhat different depending upon the type of engine used.

A₁-A₅ indicate the periods for which the valve of the fuel injector 66 is open, i.e. fuel injection periods. The lengths JD of the periods A₁-A₅ can be considered to be the quantities of fuel injected at a time by the fuel injectors 66. The injectors 66, provided for the respective cylinders, are connected in parallel with the drive circuit in the control circuit 10. Accordingly, the signal INJ from the control circuit 10 opens the valves of the fuel injectors 66 simultaneously so that all the fuel injectors 66 simultaneously inject fuel. Now, the first cylinder will be taken as an example for description. The output signal INJ from the control circuit 10 is applied to the fuel injectors 66 provided respectively in the manifold or inlet ports of the respective cylinders in timing with the reference signal INTIS generated at 360° of crank angle. As a result, fuel is injected in by the injector 66 for the length JD of time calculated by the control circuit 10, as shown at A₂ in FIG. 2. However, since the suction valve of the 1st cylinder is closed, the injected fuel at A₂ is not sucked into the 1st cylinder, but kept stagnant near the inlet port of the 1st cylinder. In response to the next reference signal INTIS generated at 720° of crank angle, the control circuit 10 again sends a signal to the respective fuel injectors 66 to perform the fuel injections as shown at A₃ in FIG. 3. Simultaneously almost with the fuel injections, the suction valve of the 1st cylinder is opened to cause the fuel injected at A₂ and the fuel injected at A₃ to be sucked into the combustion chamber of the 1st cylinder. The other cylinders will be also subjected to similar series of operations. For example, in case of the 5th cylinder corresponding to the diagram C, the fuel injected at A₂ and A₃ is sucked in at the period J₅ for which the suction valve of the 5th cylinder is opened. In case of the 3rd cylinder corresponding to the diagram D, a part of the fuel injected at A₂, the fuel injected at A₃ and a part of the fuel injected at A₄ are sucked in together while the suction valve is open for the period J₃. The part of the fuel injected at A₂ plus the part of the fuel injected at A₄ equals a quantity of fuel injected by a fuel injector at a single actuation. Therefore, also during the suction step of the 3rd cylinder, the quantity of fuel equal to the total quantities supplied through double actuations of the fuel injector will be sucked in. Also, in case of the 6th, 2nd or 4th

cylinder as shown in the diagram E, F or G, the double quantity of fuel is sucked in during a single step of suction. As apparent from the above description, the quantity of fuel determined by the fuel injection signal INJ from the control circuit 10 is equal to half the quantity of fuel to be sucked into the combustion chamber. Namely, the necessary quantity of fuel corresponding to the quantity of air sucked into the combustion chamber 34 will be supplied through the double actuations of the fuel injector 66.

Throughout the diagrams A to G in FIG. 2, G₁-G₆ indicate the ignition times associated respectively with the 1st to 6th cylinders. When the power transistor provided in the control circuit 10 is cut off, the primary current of the ignition coil 40 is interrupted so that a high voltage is induced across the secondary winding. The induction of the high voltage takes place in timing with the ignition epochs G₁, G₅, G₃, G₆, G₂ and G₄. The induced high voltage is distributed to the spark plugs provided in the respective cylinders by means of a distributor 38. Accordingly, the spark plugs of the 1st, 5th, 3rd, 6th, 2nd and 4th cylinders fire successively in this order to inflame the combustible mixture of fuel and air.

FIG. 3 shows an example of the detail of the control circuit 10 shown in FIG. 1. The positive power source terminal 90 of the control circuit 10 is connected with the positive electrode 110 of a battery to provide a voltage VB for the control circuit 10. The power source voltage VB is adjusted to a constant voltage PVCC of, for example, 5 volts by a constant voltage circuit 112. This constant voltage PVCC is applied to a central processor unit (hereinafter referred to as CPU), a random access memory (hereafter referred to as RAM) and a read-only memory (hereafter referred to as ROM). The output PCVV of the constant voltage circuit 112 is supplied also to an input/output circuit 120.

The input/output circuit 120 includes therein a multiplexer 122, an analog-digital converter 124, a pulse output circuit 126, a pulse input circuit 128 and a discrete input/output circuit 130.

The multiplexer 122 receives plural analog signals, selects one of the analog signals in accordance with the instruction from the CPU, and sends the selected signal to the A/D converter 124. The analog signal inputs applied through filters 132 to 144 to the multiplexer 122 are the outputs of the various sensors shown in FIG. 1; the analog signal TW from the sensor representing the temperature of the cooling water in the water jacket of the engine, the analog signal TA from the sensor 16 representing the temperature of the sucked air, the analog signal TE from the sensor 84 representing the temperature of the exhaust gas, the analog signal QTH from the throttle aperture detector 24 representing the aperture of the throttle valve 20, the analog signal OE from the exhaust recycle apparatus 28 representing the aperture of the valve of the apparatus 28, the analog signal V_λ from the λ sensor 80 representing the air-excess rate of the sucked mixture of fuel and air, and the analog signal QA from the air-flow meter 14 representing the flow rate of air. The output V_λ of the λ sensor 80 above is supplied through an amplifier with a filter circuit to the multiplexer 122.

The analog signal VPA from an atmospheric pressure sensor 146 representing the atmospheric pressure is also supplied to the multiplexer 122. The voltage VB is applied from the positive power source terminal 90 to a series circuit of resistors 150, 152 and 154 through a

resistor 160. The series circuit of the resistors 150, 152 and 154 is shunted with a Zener diode 148 to keep the voltage across it constant. To the multiplexer 122 are applied to the voltages VH and VL at the junction points 156 and 158 respectively between the resistors 150 and 152 and between the resistors 152 and 154.

The CPU 114, the RAM 116, the ROM 118 and the input/output circuit 120 are interconnected respectively by a data bus 162, an address bus 164 and a control bus 166. A clock signal E is supplied from the CPU to the RAM, ROM and input/output circuit 120 and the data transfer takes place through the data bus 162 in timing with the clock signal E.

The multiplexer 122 of the input/output circuit 120 receives as its analog inputs the cooling water temperature TW, the temperature TA of the sucked air, the temperature TE of the exhaust gas, the throttle valve aperture QTH, the quantity QE of the recycle exhaust gas, the output V_λ of the λ sensor, the atmospheric pressure VPA, the quantity QA of the sucked air and the reference voltages VH and VL. The quantity QA of the sucked air may be replaced by the negative pressure VD in the intake manifold. The CPU 114 specifies the address of each of these analog inputs through the address bus 164 in accordance with the instruction program stored in the ROM 118 and the analog input having a specified address is taken in. The analog input taken in is sent through the multiplexer 122 to the analog/digital converter 124 and the output of the converter 124, i.e. the digital-converted value, is held in the associated register. The stored value is coupled, if desired, to the CPU 114 or RAM 116 in response to the instruction sent from the CPU 114 through the control bus 166.

The pulse input circuit 128 receives as inputs a reference pulse signal PR and an angular position signal PC both in the form of a pulse train from the angular position sensor 98 through a filter 168. A pulse train of pulses PS having a repetition frequency corresponding to the speed of the vehicle is supplied from a vehicle speed sensor 170 to the pulse input circuit 128 through a filter 172. The signals processed by the CPU 114 are held in the pulse output circuit 126. The output of the pulse output circuit 126 is sent to a power amplifying circuit 186 and the fuel injector 66 is controlled by the output signal of the power amplifying circuit 86.

Power amplifying circuits 188, 194 and 198 respectively control the primary current of the ignition coil 40, the aperture of the exhaust recycle apparatus 28 and the aperture of the air regulator 48 in accordance with the output pulses of the pulse output circuit 126. The discrete input/output circuit 30 receives signals from a switch 174 for detecting the completely closed state of the throttle valve 20, from a starter switch 176, and from a gear switch 178 indicating that the transmission gear is in the top position, respectively through filters 180, 182 and 184 and holds the signals. The discrete input/output circuit 130 also receives and holds the processed signals from the central processor unit CPU 114. The discrete input/output circuit 130 treats the signals the content of each of which can be represented with a single bit. In response to the signal from the central processor unit CPU 114, the discrete input/output circuit 130 sends signals respectively to the power amplifying circuits 196, 200, 202 and 204 so that the exhaust recycle apparatus 28 is closed to stop the recycle of exhaust gas, the fuel pump is controlled, the abnormal temperature of the catalyzer is indicated by a

lamp 208 and the overheat condition of the engine is displayed by a lamp 210.

FIG. 4 shows in detail a concrete example of the pulse output circuit 126. A register group 470 comprises reference registers which serve to hold the data processed by the CPU 114 and the data representing the predetermined fixed values. These pieces of data are transferred from the CPU 114 to the reference register group 470 through the data bus 162. Each of the registers is specified through the address bus 164 to receive and hold the associated data.

A register group 472 comprises instantaneous registers which serve to hold the instantaneous states of the engine and the associated mechanisms. The instantaneous register group 472, a latch circuit 476 and an incrementor 478 form a counter.

An output register group 474 comprises, for example, a register 430 for holding the rotational speed of the engine and a register 432 for holding the vehicle speed. The registers 430 and 432 hold the values by taking in the contents of the instantaneous registers when certain conditions are satisfied. Each register of the output register group 474 is selected by the signal sent from the CPU 114 through an address bus and the content of the selected register is sent to the CPU 114 through the data bus 162.

A comparator 480 receives, for comparison, at its input terminals, 482 and 484 the reference data from selected registers of the reference register group and the instantaneous data from selected registers of the instantaneous register group. The result of the comparison by the comparator 480 is delivered at its output terminal 486. The output delivered at the output terminal 486 is set in the selected registers of a first comparison output register group 502 serving as a comparison result holding circuit, and then set in the corresponding registers of a second comparison output register group 504.

The operations of accessing, i.e. reading out of or writing in, the reference register group 470, the instantaneous register group 472 and the output register group 474, the operations of the incrementor 478 and the comparator 480, and the operations of setting the output of the comparator 480 in the first and second comparison output register groups 502 and 504 are all processed within a predetermined period of time. Other various processing operations are performed in time sequential manner or in a time-division manner in accordance with the order of the stages instructed by a stage counter 572. In each stage, one of the registers constituting the reference register group 470, one of the registers of the instantaneous register group 472, one of the registers of the first comparison result register group 502, one of the registers of the second comparison result register group 504 and, if necessary, one of the registers of the output register groups 474 are selected. The incrementor 478 and the comparator 480 are used in common.

FIG. 5 shows diagrams useful in explaining the operation of the circuit in FIG. 4. The clock signal E, shown in the diagram A, is supplied from the CPU 114 to the input/output circuit 120. Two clock signals $\phi 1$ and $\phi 2$, as shown in the diagram B and D, having no overlap with each other are derived from the clock signal E by means of a pulse generating circuit 574. The circuit shown in FIG. 4 is operated by these clock signals $\phi 1$ and $\phi 2$.

The diagram D in FIG. 5 depicts a stage signal which is switched over during the rising transient of the clock

signal $\phi 2$. The processing in each stage is performed in synchronism with the clock signal $\phi 2$. In FIG. 5, "THROUGH" indicates that the latch circuit and the register circuits are in their enabled conditions and that the outputs of these circuits depend on the inputs thereto. Also, "LATCH" means that these circuits hold certain data and that the outputs therefrom are independent of the inputs thereto.

The stage signal shown in the diagram D serves to read data out of the reference register group 470 and the instantaneous register group 472, that is, to read out the contents of certain selected registers of the groups. The diagrams E and F represent the operations of the reference and instantaneous register groups 470 and 472, respectively. These operations are performed in synchronism, with the clock signal $\phi 1$.

The diagram G indicates the operation of the latch circuit 476. The latch circuit 476 is in the THROUGH state when the clock signal $\phi 2$ is at high level, serving to take in the content of a particular register selected from among the instantaneous register group 472. When the clock signal $\phi 2$ is at low level, on the other hand, the latch circuit 476 is in the LATCH state. Thus, the latch circuit 476 serves to hold the content of the specific register of the instantaneous register group selected in accordance with the stage assumed then. The data held in the latch circuit 476 is increased or not on the basis of external conditions by means of the incrementor 478 operator out of timing with the clock signal.

The incrementor 478 performs the following functions in response to the signal from the incrementor controller 490. The first function is the function of incrementing, to increase by unity the value of the input data. The second is the function of non-incrementing, to pass the input without any change. The third is the function of resetting, to change the entire input into data representing the value 0 (zero).

As seen from the flow of data through the instantaneous register group 472, one register of the group 472 is selected by the stage counter 572 and the data held by the selected register is supplied to the comparator 480 through the latch circuit 476 and the incrementor 478. Further, there is provided a return loop for the signal from the output of the incrementor 478 to the selected register, a complete closed loop being formed. Therefore, since the incrementor has a function of increasing the data by unity, the closed loop functions as a counter. However, if the data delivered from the particular register selected from the instantaneous register group is again received by the particular register as an input by coming back through the return loop, an erroneous operation will easily take place. The latch circuit 476 is provided to block unwanted data. Namely, the latch circuit 476 assumes the THROUGH state in timing with the clock signal $\phi 2$ while the THROUGH state in which input data is to be written in the instantaneous registers is in timing with the clock signal $\phi 1$. Therefore, data is interrupted or cut at the offset between the clock signals $\phi 1$ and $\phi 2$. Namely, even if the content of any specific register of the group 472 is changed, the output of the latch circuit 476 remains unchanged.

The comparator 480, just like the incrementor 478, operates out of timing with the clock signals. The comparator 480 receives as its inputs the data held in register selected from among the reference register group 470 and the data held in a register selected from among the instantaneous register group 472 and sent through the latch circuit 476 and the incrementor 478. The result of

the comparison of both data is set in the first comparison result register group 502 which takes the THROUGH state in timing with the clock signal $\phi 1$. The set data is further set in the second comparison result register group 504 which assumes the THROUGH state in synchronism with the clock signal $\phi 2$. The outputs of the register group 504 are the signals for controlling the various functions of the incrementor and the signals for driving the fuel injectors, the ignition coil and the exhaust gas recycle apparatus.

Also, in response to the signals, the results of the measurements of the rotational speed of the engine and the vehicle speed are transferred from the instantaneous register group 472 to the output register group 474 in every stage. For example, in the case of writing the rotational speed of the engine, a signal indicating that a preset time has elapsed, is held in the register RPMWBF 552 of the second comparison result register group 504 and the data held in the register 462 of the instantaneous register group 472 is transferred to the register 430 of the output register group 474 in response to the output of the register 552 in the RPM stage listed in the table 1 given later

On the other hand, unless a signal indicating the elapse of the preset time is set in the register RPMWBF 552, the operation to transfer the data held in the register 462 to the register 430 never takes place even in the RPM stage.

The data held in the register 468 of the group 472 and representing the vehicle speed VSP is transferred to the output register 432 of the group 474 in response to the signal from the register VSPWBF 556 of the group 504 in the VSP stage.

The writing of the data representing the rotational speed RPM of the engine or the vehicle speed VSP in the output register group 474 is performed as follows. Reference should be had again to FIG. 5. When the state signal STG is in the RPM or VSP mode, the data from the register 462 or 468 of the instantaneous register group 472 is written in the latch circuit 476 if the clock signal $\phi 2$ is at a high level since the latch circuit 476 takes the THROUGH state when the clock signal $\phi 2$ is at high level. And when the clock signal $\phi 2$ is at low level, the written data is in the latched state. The thus held data is then written in the output register group 474 in timing with the high level of the clock signal $\phi 1$ in response to the signal from the register RPMWBF 552 or VSPWBF 556 since the output register group 474 assumes the THROUGH state when the clock signal $\phi 1$ is at high level, as indicated at the diagram K of FIG. 5. The written data is latched at the low level of the clock signal $\phi 1$.

In the case of reading the data held in the output register group 474 by the CPU 114, the CPU 114 first selects one of the registers 430 and 432 of the group 474 through the address bus 164 and then takes in the content of the selected register in timing with the clock signal E shown in the diagram A of FIG. 5.

FIG. 6 shows an example of a circuit for generating the stage signal STG shown in the diagram D of FIG. 5. The contents of a stage counter SC570 are incremented in response to the signal $\phi 1$ sent from the pulse generating circuit 574 which is per se well-known. The outputs C_0 - C_6 of the stage counter SC570 and the outputs of the T register shown in FIG. 4 are supplied as inputs to a stage decoder SDC. The stage decoder SDC delivers as its outputs signals 01-017 and the signals

01-017 are written in a stage latch circuit STGL in timing with the clock signal $\phi 2$.

The rest input terminal of the stage latch circuit STGL receives a signal GO of bit 2° from the mode register shown in FIG. 4 and when the signal GO of bit 2° takes its low level, all the outputs of the stage latch circuit STGL are at the low level to stop all the processing operations. If, on the other hand, the signal GO resumes the high level, the stage signals STG are successively delivered again in the predetermined order to perform the corresponding processings.

The above stage decoder SDC can be easily realized by the use of, for example, a ROM (read-only memory). The table 1 given below lists up the details of the contents 00-7F of the stage signals STG delivered as outputs from the stage latch circuit STGL.

TABLE 1

(Hexadecimal)								
C ₃ -C ₆	0	1	2	3	4	5	6	7
C ₀ -C ₂								
0	EGRP	NIDL	—	RPMW	ENST	—	—	—
1	INTL	INTL	INTL	INTL	INTL	INTL	INTL	INTL
2	CYL	CYL	CYL	CYL	CYL	CYL	CYL	CYL
3	ADV	ADV	ADV	ADV	ADV	ADV	ADV	ADV
4	DWL	DWL	DWL	DWL	DWL	DWL	DWL	DWL
5	VSP	VSP	VSP	VSP	VSP	VSP	VSP	VSP
6	RPM	RPM	RPM	RPM	RPM	RPM	RPM	RPM
7	INJ	INJ	INJ	INJ	INJ	INJ	INJ	INJ
(Hexadecimal)								
C ₃ -C ₆	8	9	A	B	C	D	E	F
C ₀ -C ₂								
0	EGRD	NIDLD	—	VSPW	INTV	—	—	—
1	INTL	INTL	INTL	INTL	INTL	INTL	INTL	INTL
2	CYL	CYL	CYL	CYL	CYL	CYL	CYL	CYL
3	ADV	ADV	ADV	ADV	ADV	ADV	ADV	ADV
4	DWL	DWL	DWL	DWL	DWL	DWL	DWL	DWL
5	VSP	VSP	VSP	VSP	VSP	VSP	VSP	VSP
6	RPM	RPM	RPM	RPM	RPM	RPM	RPM	RPM
7	INJ	INJ	INJ	INJ	INJ	INJ	INJ	INJ

First, a general reset signal GR is received at the reset terminal R of the stage counter SC570 shown in FIG. 6 so that all the outputs C₀-C₆ of the stage counter SC570 become "0" (zero). The general reset signal is delivered from the CPU at the time of starting the control circuit 10. Under the above condition, if the clock signal $\phi 2$ is received, a state signal EGRPSTG is delivered in timing with the rising transient of the signal $\phi 2$. According to the stage signal EGRPSTG, a processing EGRP is performed. Upon reception of a pulse of the clock signal $\phi 1$, the stage counter SC570 counts up to increase its content by unity and then the arrival of the clock signal $\phi 2$ causes the next stage signal INTLSTG to be delivered. A processing INTL is performed according to the stage signal INTLSTG. Thereafter, a stage signal CYLSTG is delivered for the execution of a processing CYL and then a stage signal ADVSTG for a processing ADV. In like manner, as the stage counter SC570 continues to count up in timing with the clock signal $\phi 1$, other stage signals STG are delivered in timing with the clock signal $\phi 2$ and the processings according to the stage signals STG are executed.

When all the outputs C₀-C₆ of the stage counter SC570 become "1", a stage signal INJSTG is delivered for the execution of a processing INJ, which terminates the whole processings listed in the above table 1. Upon reception of the next clock signal $\phi 1$, all the outputs C₀-C₆ of the stage counter SC570 becomes zero and the stage signal EGRPSTG is delivered again for the exe-

cutation of the processing EGRP. In this way, the processings listed in the table 1 will be repeated.

The processings in the respective stages, listed in the table 1 will be detailed in the following table 2.

TABLE 2

Stage Signal	Type of Processing Operating Corresponding to Stage Signal
EGRPSTG	to determine whether or not the period of time determined by the data held in the register 418 has elapsed, so as to determine the period of the pulse current for driving the valve of the exhaust gas recycle apparatus.
INTLSTG	to determine whether or not the engine has rotated through an angle corresponding to the data held in the register 406, on the basis of the reference signal PR from the angular position sensor, so as to generate a reference

CYLSTG	to determine whether or not the reference signals INTLS represented by the data held in the register 404 have been generated, so as to generate a signal CYL indicating a single rotation of the crank shaft.
ADVSTG	to determine whether or not the engine has rotated through an angle corresponding to the data held in the register 414, on the basis of the reference signal, so as to generate an ignition timing signal.
DWLSTG	to determine whether or not the engine has rotated through an angle corresponding to the data held in the register 416, after the generation of the immediately previous reference signal, so as to generate signal indicating the initial conduction point of the primary current through the ignition coil.
VSPSTG	to hold, for detecting the vehicle speed, the data corresponding to the actually measured vehicle speed in the output register when the lapse of a predetermined period of time is ascertained on the basis of the signal (output of VSPWBF) representing the lapse of the predetermined period of time and to continue to further count the vehicle speed pulses when the predetermined period of time has not yet lapsed.
RPMSTG	to hold, for detecting the rotational speed of the engine, the data corresponding to the actually measured vehicle speed in the output register when the lapse of a predetermined period of time is ascertained on the basis of the signal (output of RPMBF) representing the lapse of the predetermined period

TABLE 2-continued

Stage Signal	Type of Processing Operating Corresponding to Stage Signal
INJSTG	of time and to continue to further count the angular position signals when the pre-determined period of time has not yet elapsed. to determine whether or not the time corresponding to the data held in the register 412 has elapsed, on the basis of the signal CYL, so as to produce a signal INJ representing the valve opening period for the fuel injector.
NIDL PSTG	to determine whether or not the time corresponding to the data held in the register 422 has elapsed, so as to determine the period of the pulse current for driving the air regulator.
RPMWSTG	to determine whether or not a predetermined period of time for which the pulses synchronous with the rotation of the engine are to be counted has elapsed, so as to measure the rotational speed of the engine.
ENSTSTG	to detect the condition that there is no signal delivered from the angular position sensor for a preset period of time, so as to detect an accidental stopping of engine.
EGRDSTG	to determine whether or not the duration of the pulse of the pulse current for driving the valve of the exhaust gas recycle apparatus has become coincident with the valve corresponding to the data held in the register 420.
NIDLDSTG	to determine whether or not the pulse duration of the pulse current for driving the air regulator has become coincident with the value corresponding to the data held in the register 424.
VSPWSTG	to determine whether or not a preset period of time for which the pulses synchronous with the vehicle speed are to be counted has elapsed, so as to measure the vehicle speed.
INTVSTG	to determine whether or not the period of time corresponding to the data held in the register 408 has elapsed.

In the stage latch circuit STGL shown in FIG. 6, the circuit components associated with the output signals STG0 and STG7 serve to synchronize externally supplied signals with the clock signal produced in the input/output circuit 120. The output STG0 is delivered when all the outputs C₀-C₂ of the stage counter SC570 as zero "0" while the output STG7 is delivered when all the outputs C₀-C₂ are one "1".

Examples of the external signals are the reference signal PR generated in timing with the rotation of the engine, the angular position signal and the vehicle speed pulse signal PS generated in synchronism with the rotation of the wheel. The periods of these signals, which are pulse signals, vary to a considerable extent and therefore the signals, if not controlled, are by no means synchronous with the clock signals $\phi 1$ and $\phi 2$. Accordingly, there is no determination of whether the increment operation is performed or not, in the stage ADVSTG, VSPSTG or RPMSTG in the table 1.

It is therefore necessary to synchronize the external pulse signal, for example, a sensor and the stage of the input/output circuit. For the improvement in the detection accuracy, the angular position signal PC and the vehicle speed signal PS must have their rising and falling transient synchronized with the stage while the reference signal PR must have its rising edge synchronized with the stage.

FIG. 7 shows the details of the register groups 470 and 472.

First, the input of data to the reference register group will be described. Input data is supplied to a latch circuit 802 through the data bus 162. Simultaneously, a read/write signal R/W and a signal VMA are supplied

from the CPU through the control bus 166. The registers in the input/output circuit are selected through the address bus 164. As is well known, a technique of selecting the registers is to decode the data sent through the address bus into the signals corresponding to the respective registers and the decoding is effected by an Address Decoder 804. The outputs of the decoder 804 are connected with the registers specified by the symbols labeled at the respective outputs (wiring is omitted). In accordance with the above mentioned read/write signal R/W, signal VMA and the address bus bit A15 corresponding to the input/output circuit, the select chip write and the select chip read signals CSW and CSR are sent through gates 806 and 808 respectively.

In the case of the writing of the data from the CPU, the select chip write signal CSW is delivered and applied to the input side of the register. Now, the select chip read signal CSR is not delivered and therefore the gate 810 is closed and the tri-state buffer 812 is closed.

The data sent through the data bus 162 is latched by the latch circuit WDL 802 in timing with the clock signal $\phi 2$. The data latched in the latch circuit 802 is transferred through the write bus driver WBD to the respective registers of the reference register group 470 and written in the registers selected by the address decoder in timing with the signal $\phi 1$. The registers 408, 410, 412, 414, 416, 426 and 428 of the group 470 have 10 bits each and both the CPU and the data bus are designed to treat data of 8 bits, so that the upper two bits and the lower eight bits of the ten-bit data are given two different addresses. Accordingly, the transfer of data to the 10-bit register takes place twice per data.

On the other hand, the reading process is contrary to this. The chip select gate 808 is selected by the output sent through the control bus and the buffer 812 is opened by the output of the gate 810 in timing with the signal E. Since at this time a desired register is selected by the address signal sent through the address bus 164, the data in the selected register is delivered through the tri-stage (three-stage) buffer 812 onto the data bus 162.

Next, description will be made of the operation to select the reference register and the instantaneous register in accordance with the stage signal. The reference and instantaneous register groups 470 and 472 receive the stage signals. In response to the stage signals, the corresponding registers are selected in the respected stages. Of the reference register group 470, the registers 412, 414 and 416 do not receive the stage signals and therefore are not selected, when the corresponding outputs INJBF, ADVBF and DWLBF are delivered from the comparison result holding register group 504. Instead, when the signals INJBF, ADVBF and DWLBF are received, the zero register 402 is selected in the stages INJ, ADV and DWL. Concerning the instantaneous register group 472, the register 456 receives the stage signals EGRP and EGRD and the register 458 receives the stage signals NIDL P and NIDLD. Thus, the register 456 is selected together with the reference register 418 or 420 in the stage EGRPSTG or EGRDSTG, respectively. And the register 458 is selected together with the reference register 422 or 424 in the stage NIDL PSTG or NIDLDSTG, respectively.

FIG. 8 shows in detail the first and second comparison output register groups 502 and 504 shown in FIG. 4. The output of the comparator 480 is divided into a signal indicating an EQUAL condition and a signal

indicating a LARGER condition and both the signals are sent to the NOR gate 832. Accordingly, the output of the NOR gate 832 indicates an EQUAL OR LARGER condition. Since the NAND gate 830 receives the EQUAL signal from the comparator 480 and the signal for selecting the ZERO register 402, the signal indicating the EQUAL condition is blocked by the NAND gate 830 is the ZERO register 402 is selected. As a result, the output of the NOR gate 832 is only the signal indicating the LARGER condition. It is necessary to select the respective registers of the first comparison output register group 502 in timing with the respective registers of the reference and instantaneous register groups. Therefore, the registers of the group 502 receives the clock signal $\phi 1$ and the corresponding stage signals to be set in synchronism with the corresponding reference and instantaneous registers. As a result, the result of comparison made in each stage is latched in the associated register of the first comparison output register group in timing with the clock signal $\phi 1$. Since the second comparison output register group 504 receives the clock signal $\phi 2$ for its set timing, the above result of comparison is set in the second comparison output register group in timing with the clock signal $\phi 2$ delayed with respect to the clock signal $\phi 1$. Then, the registers of the group 504 deliver their respective BF outputs.

The registers 512, 528, 552, 556, 516 and 520 of the second comparison output register group 504 are provided respectively with the waveform shaping circuits 840, 832, 844, 846, 848 and 850, which respectively deliver pulses INTLD, ADV D, RPMWD, VSPWD, INTVD and ENSTD performing their duties only during the period from the instant that the register group 504 is set to the next arrival of the stage signal ZEROSTG.

For the purpose of detecting the pulse train signals supplied from the various sensors to the input/output circuit, it is necessary to synchronize these pulse train signals with the operation of the input/output circuit. For, since the periods or the pulse durations of these pulse train signals vary depending on, for example, the rotational speed of the engine and the vehicle speed to considerable extends, each lengthened period may equal several times the period of the corresponding stage while each shortened period may be too short in comparison with that of the corresponding stage to exist until the corresponding stage signal is received. Therefore, if these pulse train signals are not suitably controlled, the exact counting of the pulse trains will be impossible.

FIG. 9 shows an example of a synchronizing circuit for synchronizing the external pulse train signals with the stage signals in the input/output circuit and FIG. 10 shows a timing chart useful in explaining the operation of the synchronizing circuit shown in FIG. 9.

The external input pulse signals from the various sensors, such as the reference pulses PR, the angular position signal PC and the vehicle speed signal PS are latched respectively in the latch circuits 600, 602, 604 in response to the output STGO shown in FIG. 6.

In FIG. 10, the diagram A corresponds to the waveform of the clock signal $\phi 2$, B to the clock signal $\phi 1$, and C and D to the stage signals STG7 and STG0. These stage signals are generated in timing with the clock signal $\phi 2$. The signal waveform of the diagram E is of the output pulse from the angular position sensor or the vehicle speed sensor, corresponding to the reference

pulse PR or the angular position pulse PC or the vehicle speed pulse PS. The time of occurrence, the duty cycle and the period of the signal shown in the diagram E are irregular, the signal being received independent of the corresponding stage signal.

Now, let it be assumed that the signal as shown in the diagram E is received by the latch circuits 600, 602 and 604. Then, they are latched in response to the stage signal STG0 (pulse S1 in diagram D). Accordingly, the outputs A1, A2 and A3 take the high level at an instant S2, as shown in diagram F. Also, since the input signals PR, PC and PS are at the high level when the stage signal STG0 represented by the pulse S3 is received, the high level is latched in the latch circuits 600, 602, and 604. On the other hand, since the input signals PR, PC and PS are at the low level when the stage signal STG0 represented by the pulse S4 is received, the low level is latched in the latch circuits 600, 602, and 604. As a result, the outputs A1, A2 and A3 of the latch circuits 600, 602 and 604 are as shown in the diagram F of FIG. 10. Since the latch circuits 606, 608 and 610 respectively latch the outputs A1, A2 and A3 of the latch outputs 600, 602 and 604 in response to the stage signal STG7 represented by the pulse S5 shown in the diagram C, the outputs B1, B2 and B3 of the latch outputs 606, 608 and 610 rise at the instant S6. Also, since they latch the high level when the stage signal STG7 represented by the pulse S7 is received, they continue to deliver the high level output. Therefore, the output signals B1, B2 and B3 of the latch circuit 606, 608 and 610 are as shown in the diagram G of FIG. 10.

The NOR circuit 612 receives the signal B1 and the inverted version of the signal A1 through the inverter 608 and delivers the synchronized reference signal PRS as shown in the diagram H of FIG. 10. This synchronized reference signal PRS is generated in response to the leading edge of the stage signal STG0 under the condition that the reference signal PR has changed from a low level to a high level and disappears in response to the leading edge of the stage signal STG7 and so has a pulse duration from the leading edge of the stage signal STG0 to the leading edge of the stage signal STG7. The exclusive OR circuits 614 and 616 receive the signals A2 and B2 and the signals A3 and B3. The signal S8 is generated in response to the leading edge of the stage signal STG0 when the stage signal STG0 is generated after the signal PC or PS is changed from a low to a high level and disappears in response to the leading edge of the stage signal STG7, while the signal S9 is generated in response to the leading edge of the stage signal STG0 when the signal STG0 is generated after the signal PC or PS is changed from a high to a low level and disappears in response to the leading edge of the stage signal STG7. The duty cycles of the signals S8 and S9 are equal to that of the signal shown in the diagram H of FIG. 10, and therefore determined by the stage signals STG0 and STG7.

In the above description, it is assumed that the signals PR, PC and PS have the same duty cycle and that they are simultaneously received. In practice, however, they have different duty cycles and are received at different instants. Further, each signal itself has its period and duty cycle varied with time.

The synchronizing circuit shown in FIG. 9 serves to render the irregular duration of the signal constant. The constant pulse duration is determined by the difference between the rising instants of the stage signals STG0 and STG7. Therefore, the pulse widths or durations can

be controlled by controlling the stage signals supplied to the latch circuits 600, 602, 604, 606, 608 and 610.

The pulse durations are determined depending on the timing of the stages listed in the table 1. Namely, as seen from the table 1, the stage INTL corresponds to the condition that the outputs of the counters C_0-C_2 and the outputs of the counters C_3-C_6 are respectively 1 and 0, i.e. $(C_0-C_2, C_3-C_6)=(1, 0)$ and further the conditions that $(C_0-C_2, C_3-C_6)=(1, 1), (1, 2), (1, 3) \dots$, thus the stage INTL appears every eighth stage.

Since each stage is processed in 1 μ sec, the stage INTL appears every 8 μ sec. In the stage INTL, the angular position signal PC must be detected to control the incrementor and when the output PC of the angular position sensor 98 is supplied to the synchronizing circuit shown in FIG. 9, the circuit generates the synchronizing pulses which coincide in timing with the stage INTL so that the incrementor controller is controlled by the synchronizing pulses PCS in the stage INTL.

The synchronizing pulse signal PCS is detected also in the stage ADV or RPM. The stage ADV or RPM appears whenever each of the values of the outputs C_3-C_6 is incremented by unity while each of the values of the outputs C_0-C_2 is 3 or 6, respectively. Each of the stages ADV and RPM reappears at a period of 8 μ sec.

The signal STG0 shown in FIG. 9 is delivered when the values of the outputs C_0-C_2 of the stage counter SC570 are 0 while the signal STG7 is delivered when the bits C_0-C_2 having a decimal value of 7. The stage signals STG0 and STG7 are generated independent of the outputs C_3-C_6 . As seen from FIG. 10, the synchronized signal PCS necessarily has its pulse duration existing while the outputs C_0-C_2 of the stage counter change from 0 to 6. The incrementor controller is controlled by detecting the signal in the stages INTL, ADV and RPM.

In like manner, the stage CYL for detecting the synchronized reference signal PRS takes place when the outputs C_0-C_2 of the stage counter SC570 are 2. When the angular position sensor 98 delivers the reference pulse PR, it is necessary to deliver the synchronized reference signal PRS when the outputs C_0-C_2 are 2. This requirement is satisfied by the circuit shown in FIG. 9 since the circuit delivers the pulse signal whose pulse duration lasts from the stage signal STG0 to the stage signal STG7.

The stage VSP for detecting the vehicle speed takes place only when the outputs C_0-C_2 of the stage counter are 5. It is therefore only necessary to deliver the synchronized signal PSS while the outputs C_0-C_2 are 5. This requirement is also satisfied by the circuit shown in FIG. 9 since with the circuit the outputs C_0-C_2 have the values from 0 to 6. In the circuit shown in FIG. 9, the stage signals STG0 and STG7 may be replaced respectively by the stage signal STG4 delivered when the outputs C_0-C_2 have the value of 4 and the stage signal STG6 delivered when the outputs C_0-C_2 are 6. In this case, if the signal PS is received, the synchronized signal PSS is always delivered when the outputs C_0-C_2 are 4 and 5.

Now, the cycles of the stages will be referred to. As shown in the above given table 1, 128 stage signals are produced corresponding to the values 0-127 of the outputs C_0-C_6 of the stage counter SC570. When all these 128 stage signals have been generated, a major cycle is completed to be followed by a next major cycle. Each major cycle is constituted of 16 minor cycles and each minor cycle consists of 8 stage signals. The minor

cycle corresponds to the values 0 to 7 of the outputs C_0-C_2 of the stage counter and is finished in 8 μ sec.

To exactly synchronize the pulse signals PR, PC and PS and to exactly generate the synchronized pulses PRS, PCS and PSS, it is necessary for the outputs of the sensors to have a pulse duration longer than the period of the minor cycle. For example, the duration of the angular position pulse PC is shortened as the rotational speed of engine increases. It is about 9 μ sec. for 9000 rpm. It is therefore necessary to make the period of the minor cycle shorter than 9 μ sec. so as to exactly perform the synchronizing operation even at 9000 rpm. In this embodiment, the period of the minor cycle is chosen to be 8 μ sec.

FIG. 11 shows in detail an example of the incrementor 478 shown in FIG. 4. The input terminals A0-A9 respectively receive the 10-bit data from one of the registers of the instantaneous register group, selected in accordance with the corresponding stage signal.

First, description will be made of the bit A0, i.e. signal received at the input terminal A0. The bit A0 and the count signal is supplied to the exclusive OR circuit 850. If the bit A0 is 0 (zero) and the count signal has the zero (L) level, then the signal 0 (zero) is delivered by the circuit 850. On the other hand, if the bit A0 is 1 and the count signal is the L level, the value 1 is delivered. Namely, when the count signal is 0, the bit A0 is passed without any change.

If the count signal has the 1(H) level, the bit A0 is inverted; the output of the circuit 850 is 0 when the bit A0 is 1 and when the bit A0 is 0. With respect to the bit A0, the value is counted up by unity in accordance with the count signal. When the bit A0 and the level of the count signal are both 1, a carry signal is supplied to the processing gate 854 for the upper bit A1.

The NOR gate 852 serves to detect the above said carry signal and only when there is the carry signal, the bit A1 is inverted to be delivered as an output B1. When there is no carry signal, the output B1 is the same as the bit A1. In like manner, the NOR gates 856, 860, 864, 868, 872, 876, 880 and 884 detect the corresponding carry signals and the input bits A2-A9 are supplied, as inverted versions or without change, to the exclusive OR circuits 858, 862, 866, 870, 874, 878, 882 and 886. Namely, if there are the corresponding carry signals, the bits A2-A9 are inverted to form the outputs B2-B9, respectively. In the presence of the count signal, therefore, the input bits A0-A9 are each counted up by unity to produce the output signals B0-B9.

AND gates 890-908 serve as reset mechanisms. Upon reception of a reset signal, the outputs B0-B9 become all zero, irrespective of the outputs of the exclusive OR circuits 850-886. The count signal and the reset signal for controlling the incrementor whose detail is shown in FIG. 11 are generated by the incrementor controller 490 shown in FIG. 4.

FIGS. 12A and 12B show the details of the incrementor controller 490, FIG. 12A showing a circuit for generating the count signal COUNT and the reset signal RESET for controlling the incrementor 478 and FIG. 12B showing a circuit for generating a signal MOVE for transferring data to the output register groups 430 and 432. As described before, the incrementor has three functions: the first function is to increase the value of the input data by unity, the second is to reset the input data, and the third is to pass the input data without change. The increment function, i.e. the first function to increase the value of the input data by unity, is per-

formed in response to the count signal COUNT and the reset function in response to the reset signal RESET. When the count signal is at the high level, the increment function is performed while the non-increment is performed when the count signal is at the low level. When the reset signal is at the high level, the reset function is carried out. The reset signal is given a preference over the count signal.

The various conditions are selected in response to the stage signals specified by the respective processings. The conditions refer to the synchronized external inputs and the outputs from the second comparison output register group 504. The condition for transferring data to the output register group 474 are the same as that for the control of the incrementor.

FIG. 13 illustrates a processing operation according to the fuel injection signal INJ. Since the time of starting the injection of fuel varies depending on the number of cylinder used, the initial angular position pulses INTLD derived from the reference signal PRS are counted by the register 442 serving as a CYL counter. The result of the counting is compared with the content of the CYL register 404 holding a value corresponding to the number of the cylinders. When the result of counting is greater than or equal to the content of the register 404, "1" is set in the CYL FF506 of the first comparison output register group 502 and further in the CYL BF508 of the second group 504. The CYL counter 442 is reset if the content of the CYLBF equals 1. Also, for CYLBF=1, the INJ timer 450 for measuring the fuel injection duration is reset. The content of the timer 450 is always increased unconditionally with time and compared with the content of the INJD register 412 holding the data corresponding to the fuel injection duration. When the content of the time 450 is greater than or equal to the content of the register 412, "1" is set in the INJFF 522 of the first group 502 and further in the INJBF 524 of the second group 504. The unconditional increment with time is inhibited for INJBF=1. The inverted version of the content of the register INJBF is the fuel injection duration, i.e. the valve opening period of the fuel injector.

FIG. 14 illustrates a processing according to the signal for controlling the ignition. The register 452 serving as the ADV counter is reset by the initial angular position pulse INTLD. The content of the register 452 is increased while the synchronized angular position signal PC is at the high level. The increased content of the register 452 is compared with the content of the register ADV 414 holding the data corresponding to the ignition angle. If the former is greater than or equal to the latter, "1" is set in the register ADVFF 526 of the first group 502 and further in the register ADVBF 528 of the second group 504. The signal ADVD indicating the rising part of the output of the ADVBF resets the DWL counter 454 for instructing the start of conduction. The content of the DWL counter 454 is increased while the synchronized angular position signal PC is at the high level, and then compared with the content of the DWL register 416 holding the data representing the angular position at which the electric conduction takes place, relative to the previous ignition angle. If the former is greater than or equal to the latter, "1" is set in the register DWLFF 530 of the first group 502 and further in the register DWLBF 532 of the second group 504. The output of the DWLBF 532 is the ignition control signal INGI.

FIG. 15 illustrates a processing according to the signal EGR(NIDL). The circuit elements 28 for controlling EGR, to which the signal EGR is supplied, employs a proportional solenoid and therefore the control of EGR is effected by controlling the duty cycles of the input signal. They are the EGRP register 418 for holding the period and the EGRD register 420 for holding the on-duration. The timer used in this processing is the EGR timer 456. During the processing in the stage EGRPSTG, the increment is unconditional. If the content of the EGR timer 456 proves to be greater or equal to the content of the EGRP register 418 as the result of comparison, "1" is set in the EGRPFF 534 of the first register group 502 and further in the EGRPBF 536 of the second register group 504.

During the processing in the stage EGRDSTG, the unconditional non-increment takes place and the EGR timer 456 is reset for EGRPBF=1. If, as a result of comparison, the content of the EGR timer 456 is greater than or equal to the content of the EGRD register 420, "1" is set in the EGRD register 538 of the first group 502 and further in the EGRD register 540 of the second group 504. The inversion of the output of the EGRD register 540 is in the control signal EGR.

FIG. 16 illustrates the way of measuring the rotational speed of engine RPM (or vehicle speed VSP) and the processing of the measured results. The measurement is performed by determining a certain measurement duration by the RPMW timer 460 and also by counting the synchronized angular position pulses PC within the determined duration by the same counter.

The content of the RPMW timer 460 for measuring the measurement duration is increased unconditionally and reset when the content of the RPMWBF 552 is "1". If, as a result of comparison, the content of the RPMW timer 460 is greater than or equal to the content of the RPMW register 426, "1" is set in the RPMWFF 550.

In response to the signal RPMWD representing the rising part of the output signal of the RPMWBF 552, the content of the RPM counter 462 representing the result of the count of the pulses PC is transferred to the RPM register 430 of the output register group 474. The RPM counter 462 is reset when the content of the RPMWBF 552 is "1". The processing in the stage VSPSTG is similar to that described above.

The functions of the registers used in the embodiment of this invention will be particularized below in the following table 3.

TABLE 3

No. of register	function of register
402 (ZERO.REG)	to hold the digital value corresponding to zero and to transfer the value to the comparator when required.
404 (CYL.REG)	to hold the data CYL representing the number of the used cylinders, the data CYL being used, for example, to produce a signal representing the rotation of the crank shaft through 360°.
406 (INTL.REG)	to hold the data INTL representing the crank angle and the angle between a predetermined crank angular position and the angular position of the sensor for generating the reference signal INTLS. The reference signal PR from the sensor 98 is shifted by a predetermined value in accordance with the data INTL so as to correspond to the predetermined crank angular position.
408 (INTV.REG)	to hold, as a timer, the data INTV representing the time to measure. If the data INTV is set in the register 408,

TABLE 3-continued

No. of register	function of register	
	an interruption signal can be delivered after the lapse of the time.	5
410 (ENST.REG)	to hold the data ENST representing the time used to detect the accidental stopping of the engine.	
412 (INJD.REG)	to hold the data INJD representing the valve opening period of the fuel injector.	
414 (ADV.REG)	to hold the data ADV representing the crank angle range measured from the reference angle at which the reference signal is generated to the primary current cut-off angle of the ignition coil.	10
416 (DWL.REG)	to hold the data DWL representing the crank angle range from the angle at which the immediately previous reference signal is generated to the angle at which the primary current is conducted through the ignition coil, in which range the primary current is kept cut off.	15
418 (EGRP.REG)	to hold the data EGRP representing the pulse period of the pulse current signal EGR for controlling the aperture of the valve of the EGR apparatus.	20
420 (EGRD.REG)	to hold the data EGRD representing the pulse duration of the pulse current signal EGR for controlling the aperture of the valve of the EGR apparatus.	25
422 (NIDL.P.REG)	to hold the data NIDL.P representing the period of the pulse current signal NIDL for controlling the air regulator provided to control the flow of air through the bypass of the throttle chamber.	
424 (NIDLD.REG)	to hold the data NIDLD representing the pulse duration of the pulse current signal NIDL.	30
426 (RPMW.REG)	to hold the data RPMW representing the constant period of time used to detect the rotational speed of the engine.	
428 (VSPW.REG)	to hold the data VSPW representing the constant period of time used to detect the vehicle speed.	35
442 (CYCL.REG)	to hold the instantaneous number representing the number of arrivals of the reference signal pulses.	
444 (INTLC.REG)	to hold the number of the crank angle pulses delivered after the delivery of the reference pulse from the angular position sensor 98.	40
446 (INTVT.REG)	to hold the instantaneous value of the variable which increases at regular intervals, e.g. every 1024 μ sec, after the proper data has been set in the INTV register 408.	45
448 (ENST.REG)	to hold the instantaneous value of the variable which increases at regular intervals, e.g. every 1024 μ sec, after the reference pulse has been delivered from the angular position sensor 98. The content of the register 448 is reduce to zero upon reception of the reference pulse.	50
450 (INJT.REG)	to hold the instantaneous value of the variable which increases at regular intervals, e.g. every 8 μ sec, 16 μ sec, 32 μ sec, 64 μ sec, 128 μ sec or 256 μ sec, after the CYL signal has been delivered. The above interval of time is chosen by the T register.	55
452 (ADVC.REG)	to hold the instantaneous value of the variable which increases each time the angular position sensor 98 delivers the signal PC representing the rotation of a fixed crank angle, e.g. 0.5 degree, after the reference signal INTLS has been delivered.	60
454 (DWLC.REG)	to hold the instantaneous value of the variable which increases each time the angular position sensor 98 delivers the crank angle position signal PC after the immediately previous signal INTLS has been delivered.	65
456	to hold the instantaneous value of the	

TABLE 3-continued

No. of register	function of register	
(EGRT.REG)	variable which increases at regular intervals, e.g. every 256 μ sec, after the signal EGRP has been delivered.	
458 (NIDLT.REG)	to hold the instantaneous value of the variable which increases at regular intervals, e.g. every 256 μ sec, after the signal NIDL.P has been delivered.	
460 (RPMWT.REG)	to hold the instantaneous value of the variable which increases at regular intervals of time after the second comparison result holding register 552 has delivered an output pulse.	
462 (RPMC.REG)	to hold the instantaneous value of the variable which increases each time the angular position sensor 98 delivers the angular position signal PC representing a fixed crank angle, after the second comparison result holding register 552 has delivered an output pulse.	
430 (RPM.REG)	to hold the data transferred from the register 462 in response to the output signal from the second comparison result holding register 552. The data is delivered onto the data bus in accordance with the address signal and the control instruction from the CPU 114.	
464 (VSPWT.REG)	to hold the instantaneous value of the variable which increases at regular intervals of time after the second comparison result holding register 556 has delivered an output.	
468 (VSPC.REG)	to hold the instantaneous values of the variable which increases each time one of the pulses corresponding to the rotational speed of the wheel is generated, after the second comparison result holding register 556 has delivered an output pulse.	
432 (VSP.REG)	to hold the data transferred to the register 468 in response to the output signal of the second comparison holding register 556. The data is delivered onto data bus in accordance with the address signal and the control instruction from the CPU 114.	
506 (CYLFF)	to have "1" set in if the data of the register 404 is less than or equals to the data of the register 442.	
508 (CYLBF)	to have the signal from the register 506 set in in timing with the clock signal ϕ 2.	
510 (INTLFF)	to have "1" set in if the data of the register 406 is less than or equal to the data of the register 444.	
512 (INTLBF)	to have the signal from the register 510 set in in timing with the clock signal ϕ 2.	
514 (INTVFF)	to have "1" set in if the data of the register 408 is less than or equal to the data of the register 446.	
516 (INTVBF)	to have the signal from the register 514 set in in timing with the clock signal ϕ 2.	
518 (ENSTFF)	to have "1" set in if the data of the register 410 is less than or equal to the data of the register 448.	
520 (ENSTBF)	to have the signal from the register 518 set in in timing with the clock signal ϕ 2.	
522 (INJFF)	to have "1" set in if the data of the register 412 is less than or equal to the data of the register 450.	
524 (INJBF)	to have the signal from the register 522 set in in timing with the clock signal ϕ 2.	
526 (ADVFF)	to have "1" set in if the data of the register 414 is less than or equal to the data of the register 452.	
528 (ADVBF)	to have the signal from the register 526 set in in timing with the clock signal ϕ 2.	
530 (DWLFF)	to have "1" set in if the data of the register 416 is less than or equal to the data of the register 454.	
532	to have the signal from the register 530	

TABLE 3-continued

No. of register	function of register
(DWLBF) 534	set in in timing with the clock signal $\phi 2$. to have "1" set in if the data of the register 418 is less than or equal to the data of the register 456.
(EGRPFF) 536	to have the signal from the register 534 set in in timing with the clock signal $\phi 2$.
(EGRPBF) 538	to have "1" set in if the data of the register 420 is less than or equal to the data of the register 456.
(EGRDFF) 540	to have the signal from the register 538 set in in timing with the clock signal $\phi 2$.
(EGRDBF) 542	to have "1" set in if the data of the register 422 is less than or equal to the data of the register 458.
(NIDLFFF) 544	to have the signal from the register 542 set in in timing with the clock signal $\phi 2$.
(NIDLFBF) 546	to have "1" set in if the data of the register 424 is less than or equal to the data of the register 458.
(NIDLDF) 548	to have the signal from the register 546 set in in timing with the clock signal $\phi 2$.
(NIDLDBF) 550	to have "1" set in if the data of the register 426 is less than or equal to the data of the register 460.
(RPMWFF) 552	to have the signal from the register 550 set in in timing with the clock signal $\phi 2$.
(RPMWBF) 554	to have "1" set in if the data of the register 428 is less than or equal to the data of the register 464.
(VSPWFF) 556	to have the signal from the register 556 set in in timing with the clock signal $\phi 2$.

Now, description will be made of how the reference data is set in the reference register group 470. The registers 402, 404, 406 and 410 have their data set at the time of starting the apparatus as the embodiment of this invention. The values of the data are never changed once they have been set in the registers. The setting of data in the register 408 is performed according to the programmed processing.

The register 412 receives the data INJD representing the value opening duration of the fuel injector 66. The data INJD is determined, for example, as follows. The output signal QA of the air-flow meter 14 is sent through the multiplexer 122 to the analog/digital converter 124. The digital data delivered from the A/D converter 124 is held in a register (not shown). The load data TP is obtained from the above data representing the quantity of sucked air and the data held in the register 430 shown in FIG. 4, through arithmetic operations or on the basis of the information stored in a map fashion. The outputs of the sensor 16 for the temperature of the sucked air, the sensor for the temperature of the cooling water and the sensor for the atmospheric pressure are converted to digital quantities, which are corrected according to the load data TP and the condition of the engine at operation. Let the factor of such a correction be K_1 . The voltage of the battery is also converted to a digital quantity. The digital version of the battery voltage is also corrected according to the load data TP. Let the correction factor in this case be TS. Next, the correction by the λ sensor 80 takes place and let the correction factor associated be α . Therefore, the data INJD is given by the following expression.

$$INJD = \alpha(K_1 \cdot TP + TS)$$

Thus, the valve opening duration of the fuel injector is determined. The above method of determining the data

INJD is merely an example and other methods may be employed.

The data ADV representing the ignition timing is set in the register 414. The data ADV is made up, for example, as follows. The map-like ignition data QIG with the data TP and the rotational speed as factors is held in the ROM 118. The data QIG is then subjected to starting correction, water temperature correction and acceleration correction. After these corrections, the data ADV is obtained.

The data DWL for controlling the charging period for the primary current through the ignition coil is set in the register 416. This data DWL is obtained through arithmetic operation from the data ADV and the digital value of the battery voltage.

The data EGRP representing the period of the signal EGR and the data NIDL representing the period of the signal NIDL are set respectively in the registers 418 and 422. The data EGRP and NIDL are predetermined.

The data EGRD representing the duration of opening the valve of the EGR (exhaust gas recurrent) apparatus is set in the register 420. As the duration increases, the aperture of the valve increases to increase the rate of recurrence of exhaust gas. The data EGRD is held in the ROM 118 in the form of, for example, a map-like data with the load data TP and the rotational speed as factors. The data is further corrected in accordance with the temperature of the cooling water.

The data NIDL representing the duration of energizing the air regulator 48 is set in the register 424. The data NIDL is determined, for example, as a feedback signal derived from such a feedback control that the rotational speed of the engine under no load condition always equals a preset fixed valve.

The data RPMW and VSPW representing fixed periods of time are set respectively in the registers 426 and 428 at the beginning of the operation of the apparatus.

In the foregoing description of the embodiment of this control apparatus, the output of the air-flow meter is used to control the amount of injected fuel, the advance of ignition angle and the recycle rate of exhaust gas. Any sensor other than the air-flow meter, however, may be employed to detect the condition of the sucked air. For example, a pressure sensor for detecting the pressure in the intake manifold may be used for that purpose.

As described above, according to this invention, the pulse signals received irregularly with respect to the stage cycle are synchronized so that exact detections can be assured.

Further, in the embodiment of this control apparatus described above, since the stage cycle is constituted of major cycles each of which consists of minor cycles, the detection cycle can be controlled in accordance with the precision required. Moreover, since each the stages for detecting the synchronized signals are processed for a period in the order of a minor cycle, exact detections can be assured even when the engine is operating at a high speed.

Furthermore, the above described embodiment of this control apparatus has a reference register group, an instantaneous register group and a comparison result holding register group and a register is selected from each of the register group and connected with the comparator in accordance with the outputs of the stage counter, so that many control functions can be effected by a relatively simple circuit.

FIG. 17 is a flow chart of the processing operations for the setting of the initial values in the electronic control apparatus according to this invention, that is, a flow chart of the initialization of the setting of data in the reference registers 470 in FIG. 4 and in the discrete I/O circuit 130 in FIG. 3 by the CPU, before the start of the engine.

In the step 5, the key switch (not shown) for the engine is turned on to energize all the equipment of the automobile. Then, the CPU is energized and begins to execute the engine start program held in the ROM in the following sequence.

In the step 10, desired data INTL is set in the INTL register 406, the data indicating the angular position of the angular position sensor and being used to derive the reference signal INTLS from the reference signal PR. The constant reference signal INTLS can always be generated irrespective of the location at which the angular position detector is disposed, by modifying the data in the register 406. This means that the present control apparatus can be applied to various types of engines only by modifying the data in the register 406.

In the step 15, the data corresponding to the number of the cylinders of the engine used is set in the CYL register 404. In this embodiment, for example, the number to be set is equal to half the number of the cylinders, that is, "2" for a four-cylinder engine and "3" for a six-cylinder engine. Thus, by controlling the data set in the register 404, the signal CYLBF can be generated at a fixed angular position, for various types of engines having different numbers of cylinders. In the step 20, the period of the pulse current for controlling the aperture of the EGR valve is set in the EGRP register 418. Hence, the present control apparatus can also be applied to an engine having a different type of EGR valve by merely modifying the data representing the pulse period.

In the step 25, the data representing the period of the pulse current NIDL for controlling the air regulator is set in the NIDL register 422. The period of the pulse current is suitably controlled by modifying the data when the control apparatus is applied to an engine having a different air regulator.

In the step 30, the data corresponding to the reference time used to detect the rotational speed of the engine is set in the RPMW register 426. For a different type of engine, the control apparatus is adapted by modifying the data.

In the step 35, the data representing a constant period of time used to detect the vehicle speed is set in the VSPW register 428. It is only necessary to modify this data for the application to a different type of automobile.

In the step 40, the first A/D converter is started. The analog-digital or A/D converter 124 consists of the second A/D converter A/D 2 for converting the quantity QA of sucked air to the corresponding digital signal and the first A/D converter A/D 1 for converting any analog input other than the sucked-air quantity QA to the corresponding digital signal. By starting the first A/D converter A/D 1, the analog inputs are successively coupled in through the multiplexer 122 to perform digital conversions. Upon completion of the digital conversions of all the analog inputs by the A/D converter A/D 1, "1" is held in a predetermined bit, for example the 2^5 bit, of the STATUS register by the CPU 114 and an interrupt for the completion of the digital conversions by the A/D 1 is generated.

In the step 45, the engine-stop interrupt is inhibited from occurring. Namely by transferring a "1" to the predetermined bit, for example the 2^3 bit, of the MASK register from the CPU 114, the engine-stop interrupt is inhibited from occurring even if a "1" is transferred from the ENSTBF register 520 to the corresponding bit, i.e. the 2^3 bit, of the STATUS register.

In the step 50, the desired fuel injection period or duration at the time of starting the engine is calculated on the basis of the temperature TW of water in the water jacket of the engine. Namely, the desired period of time for which the fuel injection valve is open is calculated and the calculated value is set in the INJD register 412.

In the step 55, the ignition timing at the time of starting the engine is calculated on the basis of the temperature TW of water in the water jacket. The desired crank angle, from the crank angular position at which the reference signal PR is produced, to the angular position at which the primary current through the ignition coil is cut off, is calculated and the calculated angle is set in the ADV register 414.

In the step 60, on the basis of the voltage V_B of the battery is calculated the desired instant at which the conduction of the primary current through the ignition coil is started at the time of starting the engine. The desired crank angle from the instant of generation of the immediately previous reference signal to the instant of starting the conduction of the primary current through the ignition coil, that is, the desired angle through which the primary current is kept cut off, is calculated and the result of the calculation is set in the DWL register 416.

In the step 65, the EGR valve is completely closed. Namely, a "1" is set in the predetermined address of the discrete I/O circuit 130 so that the solenoid of the exhaust gas recycling device 28 is energized by the power amplifying circuit 196 to close the EGR valve completely.

In the step 70, the NIDLE valve is fully opened. The data which is the same as that stored in the NIDL register 422, is set in the NIDL register 424. Accordingly, the pulse current signal NIDL for controlling the air regulator takes the high level during its full period so that the duty factor is unity to fully open the NIDLE valve in response to the start of the stage signal.

In the step 75, the GO signal "1" is delivered by setting "1" in a predetermined bit, for example, the 2^9 bit, of the MODE register shown in FIG. 4 in response to the completion of the above steps 25-70. The GO signal is supplied to the reset input R of the stage latch circuit STGL through an inverter shown in FIG. 6. Accordingly, the stage latch signal STGL is released from the reset state so that the circuit STGL delivers a stage signal to cause the I/O circuit 120 to start its operation in response to the stage signal.

By actuating the input/output circuit 120 after the completion of the steps 5-75, the operations of the control apparatus at and after the start of the engine in response to the turn-on of the starter switch can be performed precisely. Moreover, any different kind of engine can also be controlled properly by simply changing the setting values for the control apparatus in accordance with the specification of the engine used.

The order of the steps 10-70 may be arbitrarily changed with only the restriction that the step 40 should come before the steps 50, 55 and 60.

Further, the turn on of the starter switch before the setting of the GO signal in the MODE register fails to start the engine since the control signals for the engine (for fuel injection, ignition etc.) are not delivered until the stage cycle has been applied. Namely, the engine is always started optimally since it is started only after the setting of all the initial values has been completed.

What we claim is:

1. In a method for controlling an internal combustion engine comprising

a step of detecting the operating conditions of said engine in the normal operation;

a step of calculating desired values representative of the desired operating conditions of said engine, on the basis of the detected operating conditions;

a step of setting said desired values in respective reference registers;

a step of successively comparing the content of selected one of instantaneous registers storing instantaneous conditions of said engine respectively corresponding to said desired values with said desired value set in the corresponding one of said reference registers; and

a step of supplying control signals to means for controlling the operation of said engine in accordance with the result of the each comparison so as to optimally control said engine,

said method further comprising, prior to said detecting step, the steps of:

starting a preset program in response to the turn on of the key switch,

setting in said reference registers desired initial values representing the desired operating conditions of said engine at the time of starting in accordance with said preset program, and

starting the operation of comparing one of said desired initial values with corresponding one of said instantaneous conditions of said engine successively.

2. A method for controlling an internal combustion engine as claimed in claim 1, wherein said step of setting said desired initial values comprises

a step of detecting various conditions of said engine before the starting thereof;

a step of calculating the fuel injection duration at the starting instant on the basis of the detected conditions and of setting the calculated results as desired value for initial control in one of said reference registers; and

a step of calculating the instant of starting the conduction of current through the ignition coil and the instant of interrupting said current, at the time of starting said engine, on the basis of said detected conditions and of setting the calculated results as desired values for initial control in some of said reference registers.

3. A method for controlling an internal combustion engine as claimed in claim 2, wherein said conditions of said engine before starting are the temperature of the cooling water in the water jacket and the voltage of the battery; said fuel injection duration is calculated on the basis of said temperature detected immediately before the starting of said engine; and said instant of starting said conduction of said current through said ignition coil is calculated on the basis of the voltage of said battery detected immediately before starting said engine while said instant of interrupting said current is calcu-

lated on the basis of said temperature detected immediately before starting said engine.

4. A method for controlling an internal combustion engine as claimed in claim 2, wherein said means for controlling said operating conditions of said engine comprises a fuel injecting valve, an ignition coil and an air regulator.

5. A method for controlling an internal combustion engine as claimed in claim 3, wherein said step of setting said desired values for initial control further includes therein a step of setting in one of said reference registers a period of time indicating the time of accidental stop of said engine as a desired initial value for said initial control and a step of setting data representing the fully opened aperture of the air-regulator valve in another of said reference registers, and wherein said method further comprises a step of setting data representing the complete closure of the valve for controlling the exhaust gas recycle before the start of said comparison operation and a step of actuating a means for nullifying the result of comparison of said period of time indicating said accidental stop of said engine with the corresponding instantaneous condition of said engine.

6. A method for controlling an internal combustion engine as claimed in claim 5, wherein said step of setting said desired values for initial control in said reference registers includes therein a step of setting the number corresponding to the number of the cylinders of said engine; a step of setting the deviation of the angular position of the sensor for detecting the crank angle from the reference angular position of the crank; a step of setting the period for which the valve for controlling the exhaust gas recycle is open; a step of setting the period for which the air-regulator valve is open; a step of setting time data for the measurement of the rotational speed of said engine; and a step of setting time data for the measurement of the vehicle speed.

7. In a microprocessor-controlled apparatus for controlling the operation of an internal combustion engine comprising means for detecting the operating conditions of said engine;

a control apparatus comprising:

means for controlling the operating conditions of said engine;

a reference register group consisting of reference registers for respectively holding said desired values delivered from said microprocessor;

an instantaneous register group consisting of instantaneous registers for respectively holding the pieces of data representing the instantaneous conditions of said engine respectively corresponding to said desired values;

means for comparing successively the selected one of said desired values in said reference registers with the corresponding one of said pieces of data representing said instantaneous conditions of said engine, held in said instantaneous registers and for supplying the results of the comparison as control signals to said means for controlling said operating conditions of said engine; and

a selecting means for sequentially selecting one of said desired values in said reference registers in a predetermined order, simultaneously reading said instantaneous conditions selectively out of the corresponding instantaneous registers, and supplying the read conditions to said comparison means, and wherein said microprocessor sets in said reference registers said desired values for initial control at the

start of said engine in response to the turn on of the key switch and then actuates said selecting means after the completion of the setting of said desired values in said reference registers.

8. A control apparatus, as claimed in claim 7, wherein said means for controlling the operating conditions of said engine comprises a fuel injection valve, an ignition coil, an exhaust gas recycling means and an air regulator.

9. A control apparatus, as claimed in claim 8, wherein said microprocessor reads the conditions of said engine before the start thereof as the detected values from said detecting means in response to the turn on of the key switch; calculates the fuel injection duration, the instant of starting the conduction of current through the ignition coil and the instant of interrupting said current on the basis of said detected values; and sets the calculated values as desired values for initial control in said reference registers.

10. A control apparatus, as claimed in claim 9, wherein said conditions of said engine before starting, detected by said detecting means, are the temperature of the cooling water in the water jacket and the voltage of the battery; said fuel injection duration is calculated on the basis of said temperature detected immediately before the starting of said engine; and said instant of starting said conduction of said current through said ignition coil is calculated on the basis of the voltage of said battery detected immediately before starting said engine while said instant of interrupting said current is calculated on the basis of said temperature detected immediately before starting said engine.

11. A control apparatus, as claimed in claim 10, wherein said microprocessor sets a period of time indicating the time of accidental stopping of said engine as a desired value for said initial control in one of said reference registers in response to the turn on of the key switch and also sets data indicating the fully opened aperture of the valve of the air regulator as a desired value for said initial control in another of said reference registers, wherein said apparatus further comprises a means for closing the valve of the exhaust gas recycling means and a MASK means for inhibiting the output as the result of the comparison between said desired value representing said period of time and the corresponding condition of said engine, and wherein said microprocessor energizes said means for closing said valve of said exhaust gas recycling means and said MASK means before the operation of said selecting means in response to the turn on of said key switch.

12. A control apparatus, as claimed in claim 7, further comprising a mode register, wherein said microprocessor sends a signal for instructing said selecting means to said mode register after the setting of said desired values for said initial control in said reference registers has been completed, and said mode register hold said instructing signal, once said mode register receives said instructing signal, and continues to actuate said selecting means while said instructing signal is being held.

13. In a control apparatus for an internal combustion engine having:

- sensor means for producing signals representative of operating conditions of said engine;
- actuator means for controlling respective energy conversion functions of said engine in response to control signals applied thereto;

an input/output unit coupled to receive signals produced by said sensor means, and to deliver control signals to said actuator means, and

a data processing unit, coupled to said input/output unit, for carrying out engine control data processing operations in accordance with signals produced by said sensor means and thereby generating engine control codes that are coupled to said input/output unit;

said input/output unit comprising:

first means for generating an engine control timing signal pattern through which operational events of said engine are controlled;

second means, coupled to said data processing unit, for storing said engine control codes;

third means, coupled to said first means, for generating respective engine timing codes the values of which are selectively modified by said engine control timing pattern;

fourth means, coupled to said second and third means, for comparing respective ones of said engine control codes with respective ones of said engine timing codes and producing respective output signals when said respective engine control codes define a prescribed relationship with respect to said engine timing codes;

fifth means, coupled to said fourth means, for producing control signals to be coupled to said actuator means in response to the output signals produced by said fourth means; and

sixth means, coupled to said third means and responsive to first prescribed data supplied by said data processing unit, for enabling the generation of engine timing codes by said third means.

14. A control apparatus according to claim 13, wherein said sixth means include means, responsive to second prescribed data supplied by said data processing unit, for disabling the generation of engine timing codes by said third means.

15. A control apparatus according to claim 13, wherein said apparatus is adapted to be coupled to a source of power for operating said apparatus and said first prescribed data is supplied by said data processing unit in response to the application of power from said power source to said apparatus.

16. A control apparatus according to claim 15, wherein said apparatus includes a starter switch coupled with said power source for selectively causing the application of power from said power source to said apparatus.

17. A control apparatus according to claim 15, wherein an initial set of engine control codes governing the starting operation of the engine are coupled from said data processing unit to said second means in response to the application of power from said power source to said apparatus.

18. A control apparatus according to claim 14, further including seventh means, responsive to a prescribed operating condition of the engine, for causing said data processing unit to supply to said sixth means said second prescribed data, in response to which the generation of engine timing codes by said third means is disabled.

19. A control apparatus according to claim 18, further comprising eighth means, coupled with said seventh means and responsive to third prescribed data supplied by said data processing unit, for selectively enabling said seventh means to cause said data processing unit to supply said second prescribed data in the

event of occurrence of said prescribed operating condition of the engine.

20. A control apparatus according to claim 19, wherein said prescribed operating condition of the engine corresponds to a rotation of the engine crankshaft at a speed less than a prescribed value.

21. A control apparatus according to claim 19, wherein said prescribed operating condition of the engine corresponds to the condition that the engine is effectively stopped.

22. A control apparatus according to claim 15, further including seventh means, responsive to a prescribed operating condition of the engine, for causing said data processing unit to supply to said sixth means said second prescribed data, in response to which the generation of engine timing codes by said third means is disabled.

23. A control apparatus according to claim 22, further comprising eighth means, coupled with said seventh means and responsive to third prescribed data supplied by said data processing unit, for selectively enabling said seventh means to cause said data processing unit to supply said second prescribed data in the event of occurrence of said prescribed operating condition of the engine.

24. A control apparatus according to claim 23, wherein said prescribed operating condition of the engine corresponds to a rotation of the engine crankshaft at a speed less than a prescribed value.

25. A control apparatus according to claim 23, wherein said prescribed operating condition of the engine corresponds to the condition that the engine is effectively stopped.

26. A control apparatus according to claim 20, wherein an initial set of engine control codes governing the starting operation of the engine are coupled from said data processing unit to said second means in response to the application of power from said power source to said apparatus.

27. A control apparatus according to claim 23, wherein an initial set of engine control codes governing the starting operation of the engine are coupled from said data processing unit to said second means in response to the application of power from said power source to said apparatus.

28. A control apparatus according to claim 27, wherein

said sixth means comprises a mode register for storing said first and second prescribed data supplied by said data processing unit,

said seventh means comprises a status register for storing interrupt data to be selectively coupled to said data processing unit in response to said prescribed operating condition of the engine, and

said eighth means comprises a mask register for storing interrupt masking data for controllably masking the interrupt data stored in said seventh means, and means for combining the interrupt data stored in said interrupt register with the masking data stored in said mask register and thereby coupling an interrupt signal to said data processing unit in accordance with the data contents of said mask and interrupt registers.

29. A control apparatus according to claim 28, wherein, in response to the application of power from said power source to said apparatus for starting the operation of said apparatus and thereby said engine, said masking register is supplied, by said data processing

unit, with mask data, said mask data inhibiting the application of an interrupt signal to said data processing unit, which interrupt signal is associated with interrupt data stored in said status register in response to the stopped condition of the engine.

30. A control apparatus according to claim 17, wherein said first prescribed data is supplied by said data processing unit to said sixth means subsequent to the coupling of at least one of the engine control codes of said initial set from said data processing unit to said second means.

31. A control apparatus according to claim 30, wherein said at least one of the engine control codes of said initial set includes a first engine control code representative of a prescribed speed of rotation of the engine crankshaft.

32. A control apparatus according to claim 30, wherein said at least one of the engine control codes of said initial set includes a first engine control code representative of the condition that the engine is effectively stopped.

33. A control apparatus according to claim 18, wherein said fifth means includes means for storing the respective output signals produced by said fourth means, said control signals being produced by said fifth means in accordance with the stored output signals from said fourth means.

34. A control apparatus according to claim 33, wherein said seventh means is coupled to be responsive to prescribed output signals from said fourth means stored by said fifth means.

35. A control apparatus according to claim 32, further including seventh means, responsive to a prescribed operating condition of the engine, for causing said data processing unit to supply to said sixth means said second prescribed data, in response to which the generation of engine timing codes by said third means is disabled.

36. A control apparatus according to claim 35, further comprising eighth means, coupled with said seventh means and responsive to third prescribed data supplied by said data processing unit, for selectively enabling said seventh means to cause said data processing unit to supply said second prescribed data in the event of occurrence of said prescribed operating condition of the engine.

37. A control apparatus according to claim 36, wherein said prescribed operating condition of the engine corresponds to the condition that the engine is effectively stopped.

38. A control apparatus according to claim 13, wherein said second means includes a first plurality of storage means in which said engine control codes are respectively stored and said third means includes a second plurality of storage means in which said engine timing codes are respectively stored, and means for selectively incrementing said timing codes stored in said second plurality of storage means in response to said engine control timing pattern, respective ones of said second plurality of storage means being associated with respective ones of said first plurality of storage means.

39. A control apparatus according to claim 35, wherein said second means includes a first plurality of storage means in which said engine control codes are respectively stored and said third means includes a second plurality of storage means in which said engine timing codes are respectively stored, and means for selectively incrementing said timing codes stored in said

second plurality of storage means in response to said engine control timing pattern, respective ones of said second plurality of storage means being associated with respective ones of said first plurality of storage means.

40. A control apparatus according to claim 39, wherein said sensor means includes rotation sensor means for generating pulse signals in accordance with the rotation of the engine crankshaft through a prescribed reference angle of rotation, and wherein one of said first plurality of storage means contains an engine control code representative of the stopping condition of the engine, and its associated one of said second plurality of storage means has its timing code reset to a prescribed value in response to pulse signals generated by said rotation sensor means.

41. A control apparatus according to claim 40, further comprising eighth means, coupled with said seventh means and responsive to third prescribed data supplied by said data processing unit, for selectively enabling said seventh means to cause said data processing unit to supply said second prescribed data in the event of occurrence of said prescribed operating condition of the engine.

42. A control apparatus according to claim 41, wherein said prescribed operating condition of the engine corresponds to the condition that the engine is effectively stopped.

43. A control apparatus according to claim 42, wherein

said sixth means comprises a mode register for storing said first and second prescribed data supplied by said data processing unit,

said seventh means comprises a status register for storing interrupt data to be selectively coupled to said data processing unit in response to said prescribed operating condition of the engine, and

said eighth means comprises a mask register for storing interrupt masking data for controllably masking the interrupt data stored in said seventh means, and means for combining the interrupt data stored in said interrupt register with the masking data stored in said mask register and thereby coupling an interrupt signal to said data processing unit in accordance with the data contents of said mask and interrupt registers.

44. A control apparatus according to claim 43, wherein, in response to the application of power from said power source to said apparatus for starting the operation of said apparatus and thereby said engines, said masking register is supplied, by said data processing unit, with mask data, said mask data inhibiting the application of an interrupt signal to said data processing unit, which interrupt signal is associated with interrupt data stored in said status register in response to the stopped condition of the engine.

45. A control apparatus according to claim 40, wherein a second of said first plurality of storage means contains an engine control code representative of a prescribed angle of rotation of said crankshaft relative to a predetermined rotational position of said crankshaft, said sensor means include an angle sensor means for generating angle pulses for the rotation of said crankshaft through angles of rotation less than that for which said rotation sensor means produces pulses, and a second of said second plurality of storage means has its timing code sequentially incremented in response to the angle pulses generated by said angle sensor means, the output signals produced by said fourth means in accor-

dance with the codes contained in said second storage means of said first and second pluralities of storage means controlling the resetting of the engine timing code of said associated one of said second plurality of storage means.

46. A control apparatus according to claim 45, wherein said actuator means include means for controlling the supply of fuel to said engine, and a third storage means of said first plurality of storage means contains an engine control code representative of the supply of fuel to said engine, and its associated third storage means of said second plurality of storage means has its timing code sequentially incremented beginning in response to selected one of the pulse signals generated by said rotation sensor means and reset in response to a selected subsequent pulse signal generated by said rotation sensor means.

47. A control apparatus according to claim 46, wherein said selected one and said selected subsequent pulse signals generated by said rotation sensor means are selected in accordance with the number of cylinders of the engine.

48. A control apparatus according to claim 46, wherein said actuator means further include means for controlling the timing of ignition of the fuel supplied to the engine, and a fourth storage means of said first plurality of storage means contains an engine control code representative of the rotation of said crankshaft from its position at which said fourth means produces an output signal in response to a comparison of the codes contained in said ones of said first and second pluralities of storage means to the position of said crankshaft at which current in an ignition coil is cut off, and an associated fourth storage means of said second plurality of storage means has its timing code incremented beginning in response to each pulse signal generated by said rotation sensor means and reset in response to the next succeeding pulse signal generated by said rotation sensor means.

49. A control apparatus according to claim 30, wherein said first prescribed data is supplied by said data processing unit to said sixth means subsequent to the coupling of each of the engine control codes of said initial set from said data processing unit to said second means.

50. A control apparatus according to claim 49, wherein said engine control codes include codes representative of at least one of the number of cylinders of the engine, a prescribed angle of rotation of the crankshaft, the operation of the exhaust gas recycle valve, the operation of bypass air regulator, the rotational speed of the engine, vehicle speed, fuel supply duration, and ignition timing.

51. An electronic engine control apparatus for an internal combustion engine comprising

a power source for supplying a power to said apparatus;

a plurality of sensors for detecting operating conditions of the engine;

a digital converter for converting analog outputs of said sensors into corresponding digital quantities; actuators for controlling said engine;

digital processing means for receiving the outputs of said sensors and the outputs of said digital converter and for outputting various digital data corresponding to settings of said actuators;

a first plurality of storage means for storing the outputs of said digital processing means as various reference values;
 counting means for counting digital values representing instantaneous states of said actuators and said engine, said counting means including a second plurality of storage means corresponding to said first plurality of storage means for storing instantaneous data representing the states of said actuators and said engine;
 a comparator for comparing the contents of each storage means of said first plurality with the contents of the corresponding storage means of said second plurality;
 a third plurality of storage means corresponding to said first plurality of means for storing outputs of said comparator;
 transfer means for transferring to said actuators the outputs of said third plurality of storage means;
 a stage signal generator adapted to generate stage signals, corresponding to said first plurality of storage means, each of said first plurality of storage means, each of said second plurality of storage means and the corresponding storage means of said third plurality being respectively selected in accordance with said stage signals, and the output of a selected storage means of said second plurality corresponding to a respective stage signal being compared with the output of the selected storage means of said first plurality by said comparator, the outputs of said comparator being stored in the selected storage means of said third plurality, and said engine being controlled on the basis of said stored outputs; and
 stage signal generator control means for energizing said stage signal generator so as to generate said stage signals in response to first prescribed data applied from said digital processing means and for deenergizing said stage signal generator so as to prevent the generation of stage signals in response to prescribed data applied from said digital processing means, whereby said digital processing means sets in the storage means of said first plurality outputs of said digital processing means for initial control of said engine in response to the activation of said power source, and then applies and first prescribed data to said stage signal generator control means thereby energizing said stage signal generator.

52. An electronic engine control apparatus for an internal combustion engine according to claim 51, wherein said stage signal generator control means includes a mode register for controlling said stage signal generator in response to said first and second prescribed data, said mode register storing said first prescribed data applied thereto and continuing to energize said stage signal generating means during storage of the first prescribed data, and storing said second prescribed data applied thereto and continuing to deenergize said stage signal generating means during the storage of said second prescribed data.

53. An electronic engine control apparatus for an internal combustion engine according to one of claims 51 or 52, wherein said digital processing means couples data representative of a period of time corresponding to the time of accidental stopping of said engine as an engine stop reference value for initial control of said engine in one of said storage means of said first plurality

in response to the activation of said power source prior to the application of said first prescribed data to said stage signal generator control means, and wherein said apparatus further comprises

interrupt signal generating means adapted to apply to said digital processing means, as an engine stop interrupt signal, a predetermined output of a storage means of said third plurality representing the result of the comparison between said engine stop reference value and data representing the period of the engine stop condition stored in a respective storage means of said second plurality, and wherein

said digital processing means deenergizes said interrupt signal generating means, thereby preventing said engine stop interrupt signal from being applied to said digital processing means in response to the activation of said power source before the application of said first prescribed data to said stage signal generator control means.

54. An electronic engine control apparatus for an internal combustion engine according to claim 53, wherein the contents of respective storage means of said second plurality storing the data representing the period of an engine stop condition increases at regular intervals, and wherein said said sensors include a reference crank angle pulse generator for generating pulses in timing with the rotation of the crankshaft of said engine, a respective storage means of said third plurality being reset in response to said pulses after the application of said first prescribed data to said stage signal generator control means, and said comparator delivering an engine stop signal indicating an engine stop condition as a predetermined result of the comparison when the contents of said counting reaches said engine stop reference value held in the storage means of said first plurality.

55. An electronic engine control apparatus for an internal combustion engine as claimed in claim 54, wherein said interrupt signal generating means includes a status register for storing a respective output of said comparator, a mask register for storing a signal supplied from said digital processing means, and an interrupt signal generator for coupling said engine stop interrupt signal to said digital processing means in accordance with the contents of said status and mask registers, said digital processing means coupling to said mask register a signal for preventing said interrupt signal generator from delivering said engine stop interrupt signal in response to the activation of said power source prior to the application of said first prescribed data to said stage signal generator control means.

56. An electronic engine control apparatus for an internal combustion engine as claimed in one of claims 51 or 52, wherein one of said sensors comprises a first crank angle detector disposed at a first angular position for detecting the arrival of the crankshaft at a first angular position, and wherein said digital processing means couples data, as said initial reference value, representative of the deviation of said first angular position of said first crank angle detector from a reference angular position of the crankshaft of said engine in one of the storage means of said first plurality.

57. An electronic engine control apparatus for an internal combustion engine as claimed in claim 56, wherein said first crank angle detector generates a first angular pulse in synchronization with the detection of

the arrival of the crankshaft at said first angular position, and wherein said sensors include a second crank angle detector for generating a second angular pulse in synchronization with the rotation through predetermined angle of the crankshaft from said first angular position, and wherein the contents of a respective one of the storage means of said second plurality are incremented in response to said second angular pulse and are reset in response to said first angular pulse after the application of said prescribed first data to said stage signal generator control means, and said comparator delivering an initial reference angular pulse for controlling the timing of fuel injection and ignition when the contents of a respective storage means of said second plurality reach the initial reference value stored in the storage means of said first plurality.

58. An electronic engine control apparatus for an internal combustion engine as claimed in one of claims 51 or 52, wherein said digital processing means couples data, as said initial reference value, representative of the number of the cylinders of said engine in one of the storage means of said first plurality in response to the activation of said power source prior to the application of said first prescribed data to said stage signal generator control means.

59. An electronic engine control apparatus for an internal combustion engine as claimed in claim 58, wherein said sensors include a reference crank angle pulse generator for generating pulses in timing with the rotation of the crankshaft of said engine, and said actuators include a fuel injection valve, and wherein the contents of a respective one of the storage means of said second plurality are incremented in response to said pulse after the application of said first prescribed data to said stage signal generator control means, and said comparator delivering an instruction signal for opening said fuel injection valve and for resetting a respective one of the storage means of said third plurality when the contents of a respective storage means of said second plurality reaches said initial reference value stored in the storage means of said first plurality.

60. In a method for controlling an internal combustion engine using actuators for controlling said engine and digital processing means for outputting various digital data corresponding to settings of said actuators, said method comprising the steps of:

- (a) generating signals representing various operating conditions of said engine during normal operation;
- (b) generating digital data representative of the desired various operating conditions of said engine by performing data processing calculations in said digital processing means on the basis of the signals representing operating conditions;
- (c) setting into respective registers said various desired digital data as reference values;
- (d) counting digital values representing instantaneous states of said actuators and said engine, thereby obtaining counted digital values as instantaneous values associated with said reference values;
- (e) comparing successively selected ones of said reference values with the associated instantaneous values;
- (f) applying the result of comparison to said actuators for controlling said engine;

said method further comprising the steps of:

- (g) setting into said respective register initial digital data representing the desired operating conditions of said engine at the time of starting said engine as

initial reference values for the initial control in response to the activation of a power source for energizing the engine; and then

- (h) applying first prescribed data, for controlling the start of the comparing step, from said digital processing means to means for controlling the comparing operation after the initial reference value setting step, thereby starting the operation of comparing one of said initial reference values with corresponding one of said instantaneous values successively and then applying the results of the comparison to said actuators.

61. A method for controlling an internal combustion engine as claimed in claim 60, wherein step (h) includes the steps of:

- (h1) applying said first prescribed data to the comparing operation control means;
- (h2) storing said first prescribed data in said comparing operation control means in response to the application thereof; and
- (h3) executing said comparing operation while said first prescribed data is stored in said comparing operation control means.

62. A method for controlling an internal combustion engine as claimed in claim 60, wherein step (g) includes the steps of:

- (g1) setting data representative of the time of accidental stopping of said engine as an engine stop reference value for initial control of the engine in one of said reference registers, and
- (g2) applying second prescribed data from said digital processing means to means for controlling the application of the result of the comparison between said engine stop reference value and a corresponding instantaneous value representing the period of the engine stop condition to said digital processing means as an engine stop interrupt signal, thereby preventing said engine stop interrupt signal from being applied to said digital processing means.

63. A method for controlling an internal combustion engine as claimed in claim 62, wherein one of the signals generated in step (a) is a reference crank angle pulse generated in synchronism with the rotation of the crankshaft of said engine, and wherein said method includes, after the start of the comparing operation, the steps of:

- (i) counting digital clock pulses generated at regular intervals, thereby obtaining a counted value of the digital clock pulses as an instantaneous value representing the period of the engine stop condition;
- (j) resetting the engine stop instantaneous value in response to the reference crank angle pulse;
- (k) comparing said engine stop reference value with said engine stop instantaneous value;
- (l) delivering said engine stop interrupt signal when said engine stop instantaneous value is equal to or larger than said engine stop reference signal; and
- (m) preventing said engine stop interrupt signal from being applied to said digital processing means by the engine stop interrupt signal application control means.

64. A method for controlling an internal combustion engine as claimed in claim 63, wherein said engine stop interrupt signal application control means includes

- a status register for storing the result of the comparison between said engine stop reference value and said engine stop instantaneous value,

a mask register for receiving and storing said second prescribed data, and
 an interrupt signal generator for delivering said engine stop interrupt signal to said digital processing means in accordance with the contents of said status and mask registers, and wherein said initial reference values setting step includes a step of applying said second prescribed data to said mask register, and wherein said method includes, after the start of the comparing operation, the steps of:

(n) delivering the result of the comparison to said status register;

(o) preventing the result of the comparison stored in said status register from being applied to said digital processing means as said engine stop interrupt signal in accordance with the second prescribed data in said mask register, via said interrupt signal generator.

65. A method for controlling an internal combustion engine as claimed in claim 60, wherein step (g) includes the step of setting data representative of the number of cylinders of said engine as a reference value representing the predetermined crank angle.

66. A method for controlling an internal combustion engine as claimed in claim 63, wherein one of the obtained signals is a reference crank angle pulse generated in synchronization with the rotation of the crankshaft of said engine, and one of said actuators is a fuel injection value, and wherein said method includes, after the start of the comparing operation, the steps of:

- (n) counting the reference crank angle pulses;
- (o) setting in a respective register the counted value of the reference crank angle pulses as the instantaneous value representing the crank angle;
- (p) comparing the crank angle instantaneous value with the crank angle reference value;
- (q) delivering a first instruction signal for opening said fuel injection valve and a second instruction signal for resetting said crank angle instantaneous value when said crank angle instantaneous value reaches said crank angles reference value;
- (r) opening said fuel injection value in response to said first instruction signal; and
- (s) resetting said crank angle instantaneous value in response to said second instruction signal.

67. A method for controlling an internal combustion engine as claimed in claim 60, wherein one of the obtained signals is a first angular pulse generated by a first crank angular position detector disposed at a first crank angular position, said first crank angular position detector delivering said first angular pulse in response to the rotation of the crankshaft to said first angular position, and wherein (g) includes a step of setting the deviation of said first angular position of said first crank angular position detector from a reference angular position of the crank shaft.

68. A method for controlling an internal combustion engine as claimed in claim 67, wherein one of said signals is a second angular pulse generated in synchronization with said first angular position pulse, and wherein said method includes, after the start of the comparing operation, the steps of:

- (i) counting said second angular pulses;
- (j) comparing the counted value of said second angular pulses with said deviation;
- (k) delivering an initial reference angular pulse for controlling the timings of fuel injection and igni-

tion when said counted value of said second angular pulses reaches said deviation; and

- (l) resetting said counted value of said second angular pulses in response to said first angular pulse.

69. In a microprocessor-controlled apparatus for controlling the operation of an internal combustion engine comprising means for detecting the operating conditions of said engine;

a control apparatus comprising:

means for controlling the operating conditions of said engine;

a reference register group consisting of reference registers for respectively holding desired values delivered from said microprocessor;

at least one counter for counting up stage signals produced at a predetermined time interval;

a selecting means for selecting one of said desired values in said reference registers;

means for comparing successively the selected one of said desired values in said reference registers with the value of the count held in said counter;

means for supplying the results of the comparison as control signals to said means for controlling said operating conditions of said engine; and

a mode register coupled to said control apparatus and to said microprocessor for controlling the application of said control signals of said supplying means to said means for controlling said operating conditions of said engine in accordance with data delivered to said mode register from said microprocessor.

70. A control apparatus as claimed in claim 69, wherein said mode register is coupled to said supplying means.

71. A control apparatus as claimed in claim 69, wherein said mode register is coupled to said selecting means.

72. A control apparatus as claimed in claim 69, wherein said mode register enables or prevents the application of said control signals from said supplying means to said operating condition controlling means in accordance with data delivered to said mode register from said microprocessor.

73. In a control apparatus for an internal combustion engine having:

sensor means for producing signals representative of operating conditions of said engine;

actuator means for controlling respective energy conversion functions of said engine in response to control signals applied thereto;

an input/output unit coupled to receive signals produced by said sensor means, and to deliver control signals to said actuator means, and

a data processing unit, coupled to said input/output unit, for carrying out engine control data processing operations in accordance with signals produced by said sensor means and thereby generating engine control codes that are coupled to said input/output unit;

said input/output unit comprising:

first means, coupled to said data processing unit, for storing said engine control codes;

second means for generating an engine timing code;

third means, coupled to said first and second means, for comparing respective ones of said engine control codes with said engine timing code and producing respective output signals when said respective engine control codes define a prescribed relationship with respect to said engine timing code;

fourth means, coupled to said third means, for producing control signals to be coupled to said actuator

43

means in response to the output signals produced by said third means; and fifth means, coupled to said input/output unit and responsive to first prescribed data supplied by said data processing unit for controlling the application of said control signals from said fourth means to said actuator means.

74. A control apparatus as claimed in claim 73, wherein said fifth means is coupled to said fourth means.

5

10

15

20

25

30

35

40

45

50

55

60

65

44

75. A control apparatus as claimed in claims 73, wherein said fifth means enables or prevents the application of said control signal from said fourth means to said actuator means.

76. A control apparatus as claimed in claim 73, further comprising means for selecting said respective ones of said stored engine control codes which are to be compared in said third means, and wherein said fifth means is coupled to said selecting means.

* * * * *