

[54] **CONVERSION OF ISOBUTANE TO METHACROLEIN**

4,413,147 11/1983 Khoobiar 568/476
 4,532,365 7/1985 Khoobiar 568/476
 4,535,188 8/1985 Khoobiar 568/476

[75] **Inventor: Sargis Khoobiar, Kinnelon, N.J.**

FOREIGN PATENT DOCUMENTS

[73] **Assignee: The Halcon SD Group, Inc., New York, N.Y.**

623383 7/1961 Canada 568/476
 1165570 3/1964 Fed. Rep. of Germany 568/476
 48-806 1/1973 Japan 568/476
 49-28725 7/1974 Japan 568/476
 950686 2/1964 United Kingdom 568/476
 1340891 11/1970 United Kingdom 568/476
 2030885 4/1980 United Kingdom 568/476

[21] **Appl. No.: 734,433**

[22] **Filed: May 16, 1985**

Related U.S. Patent Documents

Reissue of:

[64] **Patent No.: 4,413,147**
Issued: Nov. 1, 1983
Appl. No.: 368,196
Filed: Apr. 14, 1982

Primary Examiner—Werren B. Lone
Attorney, Agent, or Firm—William C. Long; Riggs T. Stewart; Harold N. Wells

[51] **Int. Cl.⁴ C07C 45/35**

[52] **U.S. Cl. 568/476; 568/475; 585/654**

[58] **Field of Search 568/476, 475; 585/440, 585/654, 616**

[57] **ABSTRACT**

Isobutane is converted to methacrolein in an integrated two-step process wherein isobutane is dehydrogenated in a first step to isobutylene, hydrogen, and by-products and the reaction effluent is passed directly into a second step where isobutylene is oxidized to methacrolein without significant oxidation of the hydrogen and by-products. The methacrolein and by-products may be separated and the unreacted isobutylene and isobutane recycled to the first step. Alternatively, the effluent from the second step may be used as feed to a further oxidation step for conversion of methacrolein to methacrylic acid. In one embodiment, the hydrogen produced in the first step is oxidized using the excess oxygen from the second step under conditions selected to avoid loss of the C₄ components. In an alternative embodiment, the unreacted isobutane and isobutylene are absorbed and separated from the remaining components before being recycled to the first step.

[56] **References Cited**

U.S. PATENT DOCUMENTS

3,161,670 12/1964 Adams 585/654
 3,313,856 4/1967 Phielix et al. 568/476
 3,470,239 12/1972 Russell 568/476
 3,479,416 5/1967 Tschopp et al. 568/476
 3,629,701 9/1972 Box, Jr. 252/466
 3,993,593 11/1976 Katsumi et al. 568/475
 4,005,985 2/1977 Hutson, Jr. 23/288
 4,041,099 8/1977 Hutson, Jr. 585/654
 4,083,883 4/1978 Hayes 585/654
 4,144,277 3/1978 Walker et al. 568/476
 4,176,140 11/1979 Bertus et al. 568/476
 4,272,637 6/1981 Yamamoto 458/476
 4,354,044 10/1982 Aoshima et al. 568/476

13 Claims, 3 Drawing Figures

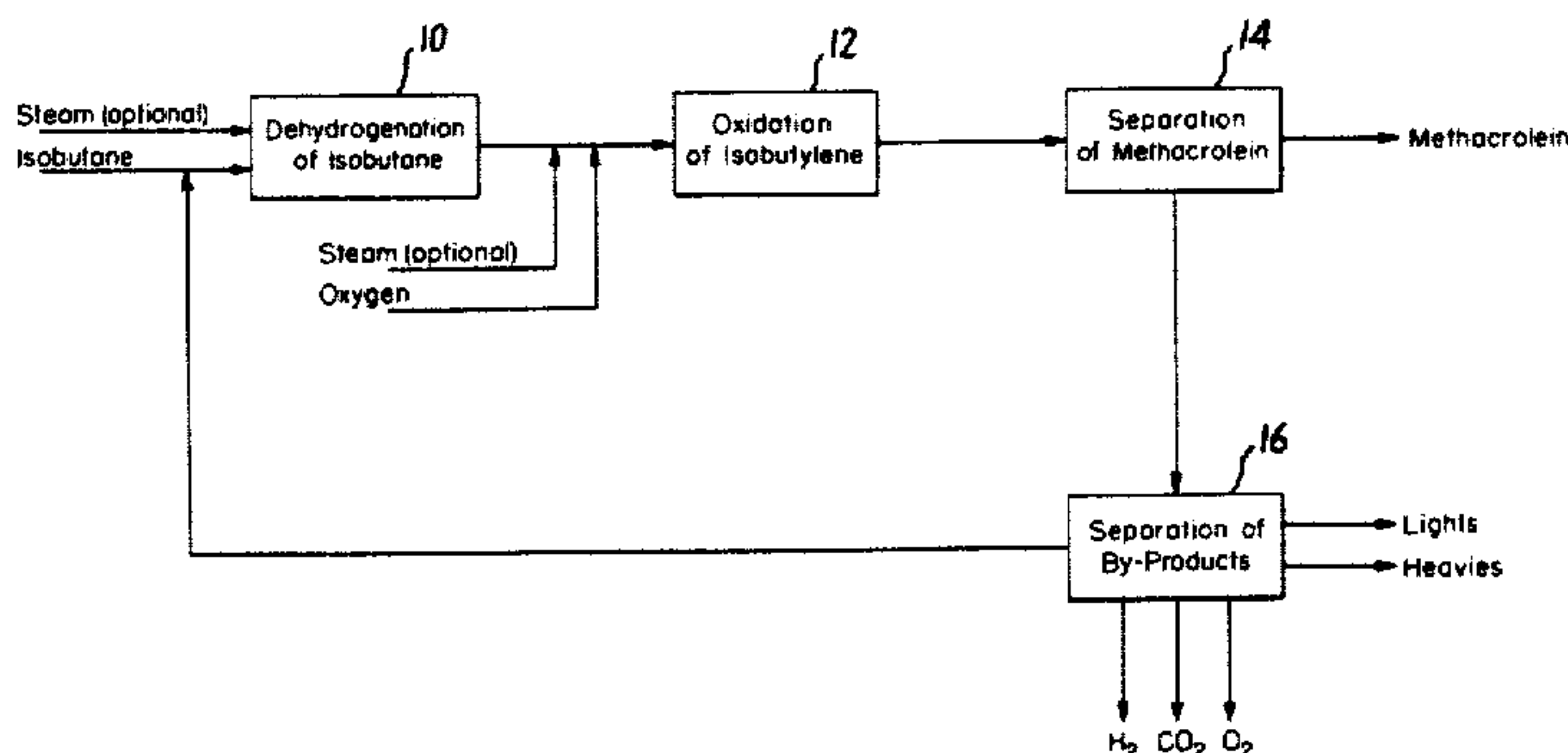

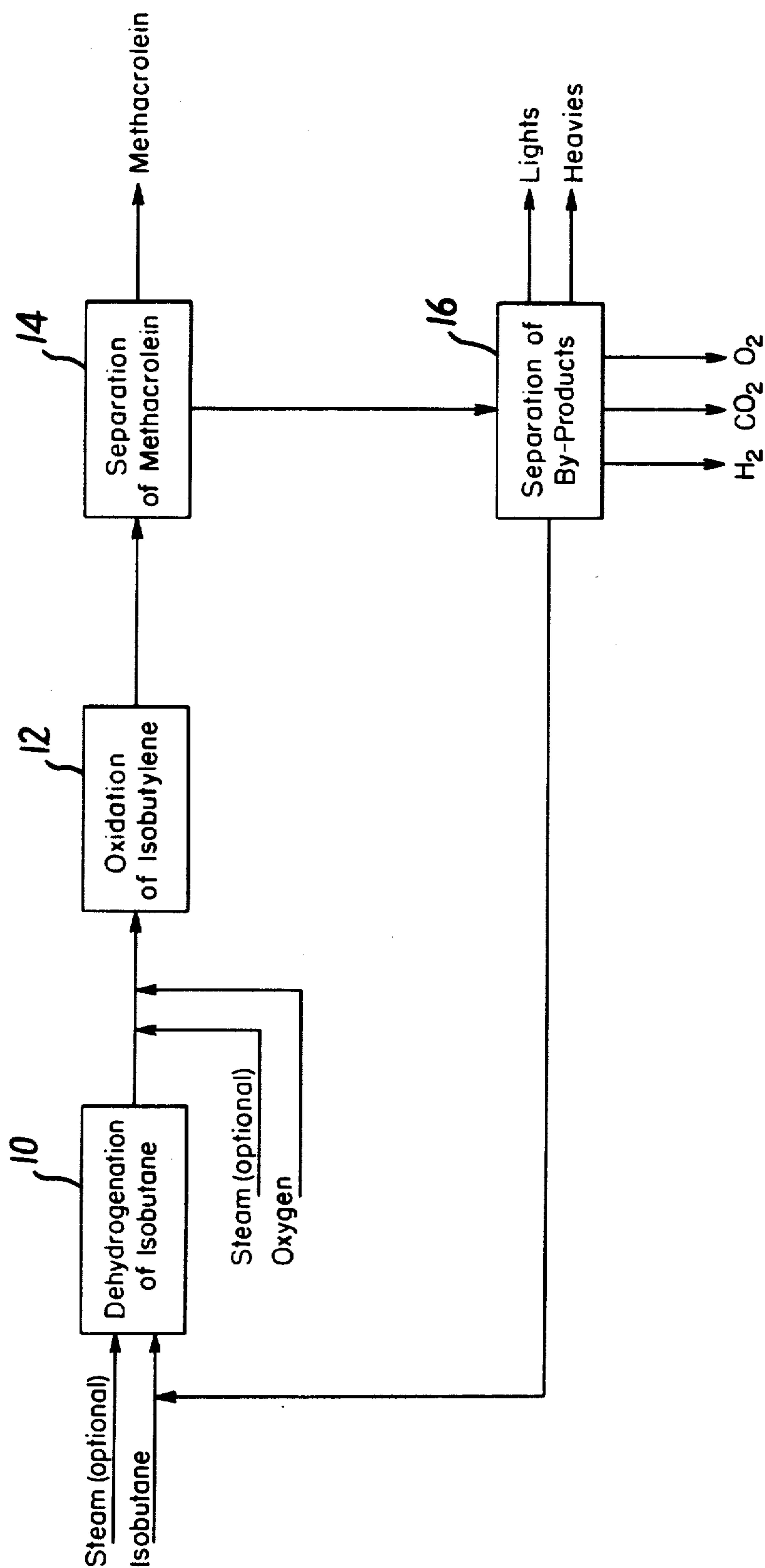

FIG. 1

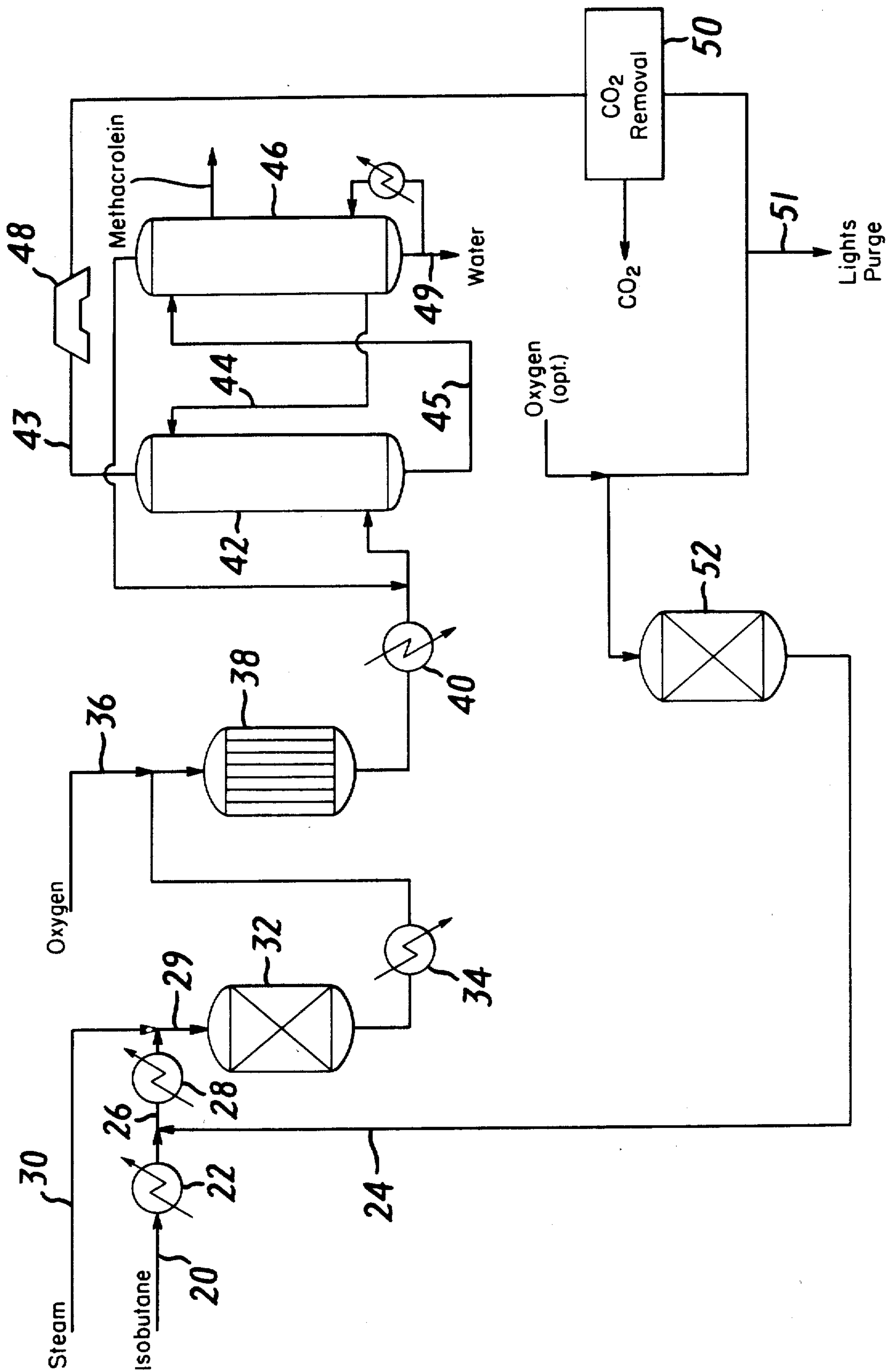

FIG. 2

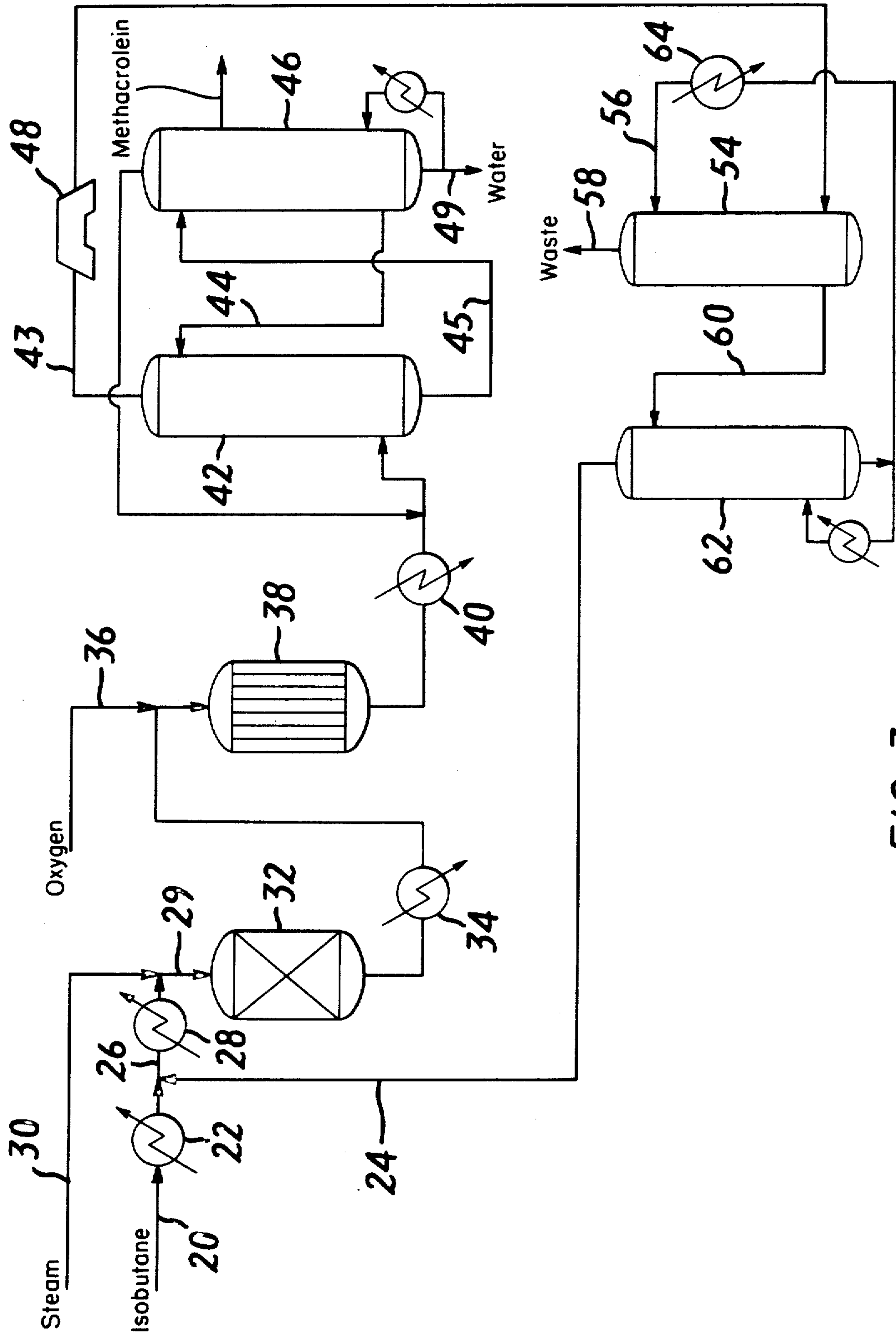

FIG. 3

CONVERSION OF ISOBUTANE TO METHACROLEIN

Matter enclosed in heavy brackets [] appears in the original patent but forms no part of this reissue specification; matter printed in italics indicates the additions made by reissue.

PRIOR ART

The invention relates generally to the preparation of methacrylic acid or methyl methacrylate. More specifically the invention relates to the preparation of methacrolein, which is a precursor of methacrylic acid in a two-step process for manufacture of methacrylic acid from isobutylene or tertiary butyl alcohol. In typical processes of the prior art isobutylene or tertiary butyl alcohol is reacted in the vapor phase with molecular oxygen over a catalyst to produce methacrolein. The methacrolein is then separated and reacted with molecular oxygen in the vapor phase over a different catalyst to form methacrylic acid. The methacrylic acid may then be reacted with a suitable alcohol to form a methacrylate ester.

Generally, the feed for this process has been the unsaturated olefin or its equivalent alcohol. Any saturated hydrocarbon present was considered to be essentially an inert since little, if any, oxidation occurred. However, an economic incentive exists for the use of isobutane as a feedstock for the preparation of methacrolein. It is known to dehydrogenate isobutane to form isobutylene for use in its many applications, such as preparing of tertiary butyl alcohol, methyl tertiary butyl ether, and butyl rubber. Such dehydrogenation processes could be used to prepare isobutylene as a feedstock for the known methods of preparing methacrolein. However, this would be an uneconomic way of preparing methacrolein and methacrylic acid.

In general, integrated processes are not generally used because the by-products of dehydrogenation must be separated, since they cannot be present in the subsequent use of isobutylene, without causing contamination of the ultimate end product. The present process relates to an integrated process whereby the dehydrogenation of isobutane is combined with the oxidation of the resulting isobutylene to methacrolein in a continuous manner and without intermediate separation of the isobutylene.

Processes of background interest include one shown in U.S. Pat. No. 3,470,239 in which isobutane is the feedstock to a process for methacrylic acid or methyl methacrylate via a tertiary butyl hydroperoxide intermediate. Isobutane is oxidized to a hydroperoxide and then used to oxidize methacrolein to methacrylic acid. In that oxidation tertiary butyl alcohol is a by-product which then can be used as a feedstock to prepare methacrolein in a conventional oxidation process. Consequently, isobutane only serves indirectly as a feedstock to the preparation of methacrolein.

In British Patent No. 1,340,891 isobutane and oxygen are reacted to prepare isobutylene and/or methacrolein over a variety of base metal oxide catalysts. Since the conversion of isobutane is quite low, high concentrations of isobutane are used so that the net amount of isobutylene or methacrolein produced is sufficient to result in an practical process.

A recent U.S. Pat. No. 4,260,822 discloses a process for direct oxidation of isobutane to methacrylic acid in

a single step, again using large amounts of isobutane in order to overcome the relatively low conversion of isobutane to the product.

The above one-step processes are not economic, since the conversions are quite low and require handling of substantial amounts of unreacted feed with recycling in order to produce a high overall conversion of isobutane. Also, the catalysts typically do not have the long useful life necessary for satisfactory commercial operations.

Since isobutylene has a number of uses other than the preparation of methacrylic acid, a number of processes have been developed for converting isobutane to isobutylene. In U.S. Pat. No. 3,784,483 a cobalt, iron, and phosphorus catalyst is used for the oxidative dehydrogenation of isobutane to isobutylene. The process of British Pat. No. 1,340,891 is similar except that generally high ratios of isobutane to oxygen (about 4/1) are used. In U.S. Pat. No. 3,479,416, a process operating in the absence of oxygen employs a base metal catalyst, particularly one containing chromium, molybdenum, and vanadium. In a group of patents typified by U.S. Pat. No. 4,083,883 a precious metal combined with promoter metals on a support is used for the dehydrogenation of paraffins, particularly normal paraffins.

Another approach is taken in U.S. Pat. Nos. 3,692,701, 4,005,985 and 4,041,099. In these processes large quantities of steam are used to dehydrogenate butanes over a catalyst of platinum-tin on zinc aluminate with a high selectivity to the corresponding butene. Relatively high conversions are achieved. Dehydrogenation of paraffins is also shown over zinc titanate catalysts in U.S. Pat. Nos. 4,144,277 and 4,176,140.

In a recent published European patent application No. 42252, isobutylene is prepared by dehydroisomerizing n-butane over a supported catalyst containing a Group IIIA element or compound, especially gallium.

Many patents have disclosed processes for oxidation of isobutylene to methacrolein. Of particular interest with respect to the present process is that disclosed in British patent application No. 2,030,885A, in which methacrolein along with oxygen and steam is passed over a molybdenum-based catalyst, providing a high conversion and selectivity to methacrolein.

Based on the prior art discussed above, one might assemble a multi-step process whereby isobutane was dehydrogenated with or without the presence of oxygen to produce isobutylene which would then be separated and purified and fed to a second step for the oxidation of isobutylene to methacrolein. In this way, a combined process could be operated which would convert substantially all of the isobutane feed to the methacrolein by merely combining known processes. This may not be an economic way to produce methacrolein. As will be seen, the present invention pertains to an integrated process by which isobutane may be converted to methacrolein without first separating isobutylene.

Dehydrogenation of isobutane produces substantial amounts of hydrogen and small amounts of lower molecular weight hydrocarbons, which in the prior art processes would be removed from the product, see for example U.S. Pat. No. 3,479,416, but which in an integrated process must be accommodated in the oxidation of isobutylene to methacrolein. The hydrogen and by-products should not have an adverse effect on the oxidation catalyst or its performance. For example, the exposure of the by-products to oxidizing conditions

cannot produce contaminants which reduce the quality of the methacrolein. Also, the presence of hydrogen should not create an explosive mixture in the oxidation reactor.

The oxidation step produces carbon oxides as by-products and some lower molecular weight oxygenated compounds and at the same time introduces oxygen into the gases which is not acceptable in the upstream dehydrogenation reactor. Thus, recycling a combined effluent from methacrolein oxidation reactor to dehydrogenation step involves particular problems unique to the integrated process of the invention. The present process is able to accommodate problems involved with the integration of the prior art process by methods to be disclosed hereinafter.

SUMMARY OF THE INVENTION

Methacrolein is prepared from isobutane in an integrated process in which dehydrogenation of isobutane to isobutylene *in the presence of steam* is followed immediately, i.e. without separation of isobutylene from the dehydrogenation effluent, by addition of oxygen and then oxidation of the isobutylene to methacrolein. Methacrolein may be recovered by scrubbing or quenching the oxidation reaction effluent which also contains unreacted isobutane, isobutylene, and oxygen, plus hydrogen, carbon oxides, *steam* and miscellaneous hydrocarbon by-products of the dehydrogenation and oxidation reactions.

In some embodiments of the invention methacrolein is recovered and then oxygen, hydrogen, and carbon oxides are removed from the oxidation reaction effluent by catalytic reactions or absorption techniques and the remaining gases containing unreacted isobutane and isobutylene are recycled to the dehydrogenation reaction. A preferred method of removing oxygen and hydrogen is to react them over a suitable oxidation catalyst at conditions selected to completely remove the oxygen, but having substantially no effect upon the isobutylene and isobutane present. Suitable catalysts include platinum or other Group VIII noble metals on alumina or other supports. The oxidation of hydrogen is carried out at a temperature which permits selective oxidation of the hydrogen. With platinum on alumina, such oxidations may be initiated at relatively low temperatures, such as ambient. In a preferred embodiment, the oxygen supplied to the oxidation reaction is adjusted to provide a limited amount in the effluent so that the hydrogen produced in the dehydrogenation reaction consumes all of the oxygen remaining after isobutylene has been oxidized to methacrolein.

In an alternative embodiment, both isobutane and isobutylene present in the effluent gases after methacrolein has been removed are absorbed with a suitable liquid such as a C₈ to C₁₀ paraffin oil. The gases can be further processed if desired to recover valuable components, burned, or otherwise disposed of. In this embodiment, the hydrogen and oxygen are contained in the waste gases and only the unconverted C₄'s are recycled to the dehydrogenation reactor.

Under suitable conditions, the effluent of the oxidation step might be fed directly to another oxidation reactor, where the methacrolein is oxidized to methacrylic acid.

The dehydrogenation of isobutane to isobutylene is carried out by a vapor-phase reaction over a suitable catalyst, which may be platinum-tin on zinc aluminate or other noble [and base] metal catalysts. When the

catalyst is platinum-tin on zinc aluminate the dehydrogenation will be carried out at about 300° to 700° C. and up to about 10 kg/cm² gauge pressure.

The oxidation of isobutylene to methacrolein may be carried out over suitable catalysts, such as mixed base metal oxides, especially molybdenum oxide-based catalysts, and particularly a catalyst comprising the oxides of molybdenum, bismuth, cobalt, iron, nickel, thallium, antimony, silica and one or more of the alkali metals.

DESCRIPTION OF THE DRAWINGS

FIG. 1 is a block diagram showing the process of the invention.

FIG. 2 is a simplified flowsheet showing one embodiment of the invention.

FIG. 3 is a simplified flowsheet showing a second embodiment of the invention.

DESCRIPTION OF THE PREFERRED EMBODIMENTS

In the principal aspect, the invention is an integrated process combining the dehydrogenation of isobutane to isobutylene with the oxidation of isobutylene to methacrolein, but without separation of the isobutylene between the two reactions. The product methacrolein is separated for further use and after separation of by-products the unreacted isobutylene and isobutane may be recycled to the dehydrogenation step if desired. A schematic view of such a complete process is shown in FIG. 1.

The process contrasts with those of the prior art in that the two reactions are operated so that the effluent from the dehydrogenation reaction 10 may be fed directly to the oxidation reaction 12 for conversion of isobutylene to methacrolein. One familiar with the prior art would expect that isobutylene would be separated from the effluent of the dehydrogenation step before feeding it to the oxidation step. Since the dehydrogenation of isobutane involves the production of significant quantities of hydrogen, as well as small amounts of lower molecular weight hydrocarbons, the isobutylene must be oxidized in the presence of significant quantities of hydrogen and by-products, without significantly affecting the oxidation of isobutylene to methacrolein or causing oxidation of the hydrogen. I have found that isobutylene may be oxidized to methacrolein in the presence of hydrogen and by-products of the dehydrogenation step, while not adversely affecting the oxidation process.

In one aspect of the invention, after methacrolein is separated (14) from the oxidation reactor effluent a gas containing unreacted isobutylene and isobutane is returned to the dehydrogenation step. Since excess oxygen is employed to oxidize isobutylene to methacrolein, this recycle stream contains substantial quantities of oxygen which may not enter the dehydrogenation step. Any oxygen present would be reacted at the operating temperature causing a loss of the C₄ components. Processes which employ oxygen in dehydrogenation characteristically use only minor amounts relative to the isobutane. Thus, in order to assemble a complete process wherein isobutane is converted only to methacrolein (plus minor amounts of by-products), it is necessary to remove (16) both the hydrogen formed during the dehydrogenation step and excess oxygen remaining after the oxidation step plus carbon dioxides and other by-products. The allowable level of each component in the gas will be adjusted as necessary. In a preferred

embodiment, carbon dioxide is scrubbed out and by-products are purged, after which hydrogen is oxidized to water over an oxidation catalyst under conditions such that substantially no loss of the C₄ components occurs. In another embodiment, the isobutane and isobutylene are scrubbed from the effluent gases and recovered for recycle to the dehydrogenation step while the gases are discarded.

The dehydrogenation of isobutane produces one mol of hydrogen for each mol of isobutylene and additional hydrogen from the formation of lower molecular weight by-products. If isobutylene is not separated before subsequent oxidation, as in this process, the hydrogen and other by-products are carried into the subsequent oxidation reaction. Oxidation of the by-products to compounds which contaminate methacrolein must be avoided. Oxidizing the hydrogen along with isobutylene would be undesirable since it would consume oxygen and interfere with the oxidation of isobutylene. Also, oxidation of hydrogen would generate undesirable heat and could create hot-spots in the reactor tubes and lower the productivity for methacrolein. However, it has been found that oxidation of isobutylene can be carried out in the presence of hydrogen with substantially no consumption of hydrogen, as will be seen in the following example.

EXAMPLE 1

A feed gas simulating the effluent expected to result from the dehydrogenation of isobutane in the presence of steam was blended and fed to an oxidation reactor for production of methacrolein. The gas composition was 7 vol % tertiary butyl alcohol, 15 vol % steam, 15 vol % oxygen, 3.2 vol % hydrogen and the balance nitrogen. Note that tertiary butyl alcohol dehydrates to form isobutylene, for which it is generally considered to be an equivalent in the oxidation reaction. The gas was passed at a gas hourly space velocity (GHSV) of 2300 hr⁻¹ and a pressure of about 1.6 kg/cm² gauge over 160 cc of a catalyst having a size of $\frac{1}{8}$ " diameter and disposed in a 0.5" i.d. tubular reactor. The heat of reaction was removed and the temperature adjusted by a circulating molten salt in the usual manner of carrying out such reactions. The oxidation catalyst had the nominal formula Mo_{0.12}Bi₁Fe₃Co₄Ni₂Tl_{0.5}Sb_{0.3}K_{0.3}Cs_{0.3}Si₇Ox.

The results of two tests are compared in the table below; test 1 shows the results with hydrogen present and test 2 shows the results after the hydrogen supply was cut off.

TABLE A

Test No.	Re-actor Temp. °C.	Conver-sion of TBA %	% Selectivity to			
			MCHO ⁽¹⁾	MAA ⁽²⁾	HOAC ⁽³⁾	CO _x ⁽⁴⁾
1	346	85.2	83.4	3.9	2.5	8.9
2	346	86.7	82.1	2.9	2.6	10.3

⁽¹⁾ MCHO - methacrolein

⁽²⁾ MAA - methacrylic acid

⁽³⁾ HOAC - acetic acid

⁽⁴⁾ CO_x - carbon oxides

The tests show differences not considered significant, but within the normal variation of the test measurements. The amount of hydrogen consumed was not accurately measured because of the small quantities involved, but it was clear from analysis of the reactor effluent that little of the hydrogen must have been ox-

dized. However, the data show that it had little or no effect in the oxidation of isobutylene to methacrolein.

Additions of small amounts of other C₄ by-products of the dehydrogenation reaction, such as n-butenes also appear to have little or no effect on the oxidation to methacrolein.

Separation of methacrolein (14) may be done by methods known to the prior art. See for example, U.S. Pat. No. 4,234,519. This may be done by cooling and condensing water-containing methacrolein from the isobutylene reactor effluent followed by scrubbing of the resulting gas with a recirculating water stream in order to complete the removal of methacrolein. The resulting methacrolein solutions may be stripped at a convenient time to produce a methacrolein-containing vapor for subsequent use. Other alternatives, such as solvent extraction and the like may be used.

Although separation of methacrolein for subsequent oxidation to methacrylic acid (or other use) is shown, it is possible, provided that the catalyst is resistant to the various compounds present, to feed the effluent of the oxidation step 12 directly to another oxidation step for conversion of methacrolein to methacrylic acid. It would be preferred to operate oxidation step 12 to convert substantially all of the isobutylene to methacrolein before carrying out the oxidation to methacrylic acid.

In its broadest form, the invention includes the combination of dehydrogenation and oxidation steps whereby the isobutane is converted to methacrolein. Such a combination process without an intermediate separation of isobutylene has been shown to be possible. If the resulting by-product stream containing significant quantities of isobutylene and isobutane can be used for other purposes, then recycling of the gas is not required. In many cases, it will be desirable to recycle unreacted isobutylene and isobutane so that the integrated process substantially converts isobutane to methacrolein with only minor amounts of by-products and without ever producing a substantially pure isobutylene stream. In order to recycle gas containing large amounts of isobutane and isobutylene, it will be necessary to remove hydrogen produced in the dehydrogenation step, excess oxygen from the oxidation step, and carbon oxides formed in both steps. In addition, a purge of light and heavy by-products and feed impurities will be taken. Removal of carbon dioxide typically would be done by scrubbing all or a portion of the recycle stream with a carbonate or amine solution known in the art in order to maintain the desired level of carbon dioxide. Carbon monoxide will be converted to carbon dioxide in the dehydrogenation reactor. Since the presence of these materials is not critical to either the dehydrogenation or oxidation steps, they may be economically permitted to build up in the recycle stream to a level in which they may be conveniently and economically removed. Since the light and heavy hydrocarbon by-products, such as methane, ethane, ethylene, propane, propylene, pentane, and pentene boil at temperatures significantly different from those of methacrolein or the C₄ hydrocarbons, they may be separated by distillation or purging of streams containing the by-products in concentrated amounts. Removal of the hydrogen formed by the dehydrogenation of isobutane might be done by various methods such as catalytic oxidation, liquid phase absorption or gas phase adsorption. In a preferred embodiment of the invention, both the hydrogen and oxygen are disposed of at the same time by reacting them to form water in a vapor phase over a suitable

oxidation catalyst under conditions such that substantially all of the hydrogen and oxygen present are removed. This can be accomplished without significant loss of the C₄ components as will be seen.

Hydrogen, as a by-product of the dehydrogenation of isobutane, must be disposed of if unreacted isobutane is to be recycled. As previously seen, the oxidation of isobutylene is carried out in such a manner that little, if any, hydrogen is consumed. According to a preferred embodiment of the invention, the amount of oxygen in the feed to the oxidation of isobutylene is adjusted so that the effluent contains no more oxygen than can react with the hydrogen present. Obviously, neither oxygen or hydrogen should be present in significant quantities in the dehydrogenation reactor, which should operate with only isobutane and steam as feeds for maximum yield. Removal of oxygen is more important, but hydrogen could be permitted in minor amounts. It has been found that such selective oxidation of hydrogen can be carried out without loss of the valuable isobutane or isobutylene, as will be seen in the following example.

EXAMPLE 2

A feed gas simulating the recycle gas after the methacrolein has been removed as product was fed to an 0.5" i.d. oxidation reactor containing 75 cc of $\frac{1}{8}$ " alumina pellets having a surface area of about 150 m²/gm and impregnated with 0.3 wt % platinum. The gas was fed at a GHSV of 2000 hr⁻¹ and about atmospheric pressure. Its composition was 30 vol % isobutane, 4 vol % hydrogen, 3 vol % oxygen, and 63 vol % nitrogen. The reaction was carried out at essentially ambient temperature, where it is found that all of the hydrogen is consumed, but substantially none of the isobutane.

While it is preferred to carry out the selective oxidation of hydrogen in the recycle gas, it is feasible to introduce the equivalent step after the dehydrogenation of isobutane and before the oxidation of isobutylene. Although some advantages would be obtained, it is considered a less economically attractive and alternative means must be provided to prevent excess oxygen from returning to the dehydrogenation step.

FIG. 2 is a simplified flowsheet showing a preferred embodiment of the invention with a complete process whereby isobutane is converted substantially to methacrolein. Fresh isobutane feed 20 is vaporized in exchanger 22 and combined with recycle stream 24 containing substantial amounts of isobutane and isobutylene. The combined stream 26 is then heated in exchanger 28 to a temperature such that when combined with the required amount of steam(30) the temperature obtained will be that suited for the dehydrogenation of isobutane to isobutylene. The amount of steam used must also be suitable for the subsequent oxidation of the isobutylene to methacrolein. As shown here, steam is supplied as a fresh feed stream. If this is done, then water produced in the reactions is eventually purged from the system from the bottom of the methacrolein stripper 46. Since the process is a net producer of water, this water may be used to provide the steam for the process. In either case, a feed stream containing isobutane and steam in molar ratios between 1/1 and 1/10, preferably $\frac{1}{2}$ to 1/5, is fed at temperatures between about 300°-700° C. preferably about 650° C. and at pressures between about 2-10 kg/cm² gauge, preferably about 3 kg/cm² gauge to reactor 32 where conversion of about 40-50% of the isobutane is converted to isobutylene with a selectivity of 90% or more.

A number of catalysts have been disclosed in the prior art for use in this process and the conditions under which the reaction is carried out will depend on the catalyst selected. Of particular usefulness is a platinum-based catalyst of the type shown in U.S. Pat. No. 4,005,985 specifically for this process. Although platinum and tin disposed on a zinc aluminate support provides good performance, other catalysts which have been found effective include platinum and rhenium supported on zinc aluminate. Other Group VIII noble metals, alone or in combination on various supports known to the art may have application in the dehydrogenation of isobutane to isobutylene.

Other potential supports would include alumina, other alkaline earth metal aluminates, and rare earth aluminates including lanthanum. Promoters such as tin, lead, antimony, and thallium may be used. Base metal catalysts such as the chromium, zirconium, titanium, magnesium and vanadium oxides as shown in U.S. Pat. Nos. 3,479,416 and 3,784,483 or the zinc titanate of U.S. Pat. Nos. 4,176,140 and 4,144,277 also might be used. The invention is not considered to be limited to specific catalyst formulations.

It will be understood by those skilled in the art that this type of process involves a rapid deactivation of the catalyst and typically the process will be operated with multiple reactors so that frequent regeneration is possible. The details of such operations are, however, not considered part of the invention. The dehydrogenation reaction is endothermic and the temperature leaving the reactor 32 will be on the order of 100°-200° C. lower than the inlet temperature. This will be affected by the amount of steam employed and the severity of the reaction conditions chosen.

The dehydrogenation reactor effluent is cooled in exchanger 34 to a suitable temperature for inlet to the oxidation reactor 38 and joined with an oxygen stream 36 to provide a suitable feed for the oxidation of isobutylene to methacrolein. Substantially pure oxygen is preferred, although less pure oxygen could be used if means were provided for purge of the additional inert gases that would normally be present. The reaction would be carried out under conditions typical of the art, that is, temperatures in the range of about 300°-400° C., pressures of about 1-8 kg/cm² gauge, and gas hourly space velocities on the order of 2000-3000 hrs⁻¹. A suitable oxidation catalyst will be used, typically a mixture of base metal oxides, especially those which are molybdenum-based, particularly a catalyst comprising the elements molybdenum, bismuth, cobalt, iron, nickel, thallium, antimony, and one or more of the alkali metals. The reactor typically will be of the tubular type where the pelleted catalyst is placed inside tubes which are surrounded by a heat transfer fluid for the removal of the heat of reaction. Typically 80-95% of the isobutylene feed to the reactor will be converted to methacrolein, along with minor amounts of methacrylic acid, acetic acid, and less significant quantities of lighter and heavier by-products. A certain amount of the isobutylene is burned to carbon oxides and water. If the reactor is operated to oxidize substantially all of the isobutylene then it may be possible to feed the reactor effluent directly to a second oxidation step for the further oxidation of methacrolein to methacrylic acid.

The resulting gaseous mixture may be cooled and fed to an absorber tower 42 where methacrolein is absorbed in a recirculating water stream 44 at temperatures in the range of about 15°-20° C. Substantially all of the meth-

acrolein is recovered in a solution containing up to about 2 mol% methacrolein. This solution may be stored for further use or may be immediately sent to a methacrolein stripper 46 where, at lower pressure and with the application of heat, methacrolein is stripped from the water and withdrawn as the vapor side stream. The stripped water is returned (44) to the top of the methacrolein absorber 42 for further use. Water produced in the process is removed (49) for disposal or recirculation as steam in the dehydrogenation step. The light gases leaving the top of the methacrolein absorber 42 contain large quantities of isobutylene and isobutane along with lesser amounts of carbon oxides, hydrogen, oxygen, and light impurities. These gases are compressed (18) if they are to be returned as a recycle stream for further conversion of the C₄'s to methacrolein. All or part of the stream may be scrubbed for removal of carbon dioxide as is shown only schematically (50), since it represents a technique familiar to those skilled in the art. For example, amine or hot carbonate scrubbing may be employed. In order to prevent build up of light impurities such as methane, ethane, ethylene, propane and propylene, a purge stream 51 may be taken continuously or intermittently from the recycle stream as shown.

The gas still contains significant quantities of hydrogen made in the dehydrogenation of isobutane and excess oxygen supplied to the oxidation reactor. Both of these must be removed. It is a feature of one embodiment of the invention to adjust the amount of oxygen supplied to the reactor 38 so that no more remains in the effluent than can be reacted with the hydrogen produced in the dehydrogenation reaction. Such an oxidation is shown being carried out in oxidation reactor 52 employing a catalyst capable of oxidizing hydrogen to water at relatively low temperatures so that the C₄ components are substantially unaffected, as has been shown in Example 2 above. Various oxidizing catalysts may be used for this purpose, such as noble metals or base metals. In particular, platinum or palladium on alumina has been found particularly useful since the reaction can be initiated at near ambient temperature. However, any convenient temperature up to about 400° C. might be employed. Alternately, platinum on a zeolite support sized to exclude C₄ hydrocarbons could be chosen. Such catalysts are capable of completely oxidizing hydrogen to water without oxidizing C₄ components. Thus, the recycle stream is passed over the selective oxidation catalyst (52) for removal of both hydrogen and oxygen and, thereafter, passed to the dehydrogenation reactor 32 for further processing.

A typical example of the practical operation of the flow sheet shown in FIG. 2 is as follows.

EXAMPLE 3

One hundred mols/hr of a feed stream containing 95% isobutane is vaporized and fed to the dehydrogenation reactor, along with 378.3 mols/hr of a recycle gas stream containing 24.9% isobutane and 19.6% isobutylene, 27% water, and essentially no oxygen or hydrogen. The combined streams 26 are heated to about 750° C. (38) and mixed with 323 mol/hr of steam (30) which may be provided by recycling and vaporizing stream 49 from the methacrolein stripper 46. The combined stream is fed to the dehydrogenation reactor 32 at about 650° C., where about 45% of the isobutane fed is converted to isobutylene. Leaving the reactor at about 520° C., the effluent stream is cooled to about 130° C. in

exchanger 34 and mixed with 171 mol/hr of oxygen (36) before being supplied to the oxidation reactor 38, where about 82% of the isobutylene is converted to methacrolein. Leaving the reactor 38 at about 342° C. and 1.4 kg/cm² gauge the effluent gases are cooled to about 150° C. and passed to the absorber 42 where the methacrolein is recovered by a recirculating water stream sufficient to produce an aqueous solution containing about 1-2 mol % methacrolein. This solution is then stripped in a reboiled stripper 46 to produce a vapor sidestream product containing 69.7 mol/hr methacrolein, 6 mol/hr methacrylic acid and 9.4 mol/hr various by-products, such as acetone, acrolein, and water. The crude recycle gas leaving the top of the absorber 42 is compressed sufficiently to permit the gas to rejoin the fresh feed to the dehydrogenation reactor 32 (about 3.9 kg/cm² gauge). The 429 mol/hr vapor contains about 23.8% hydrogen, 11.9% oxygen, 21.9% isobutane, and 17.2% isobutylene. The gas also contains carbon oxides, which are allowed to accumulate to a desired level and then maintained at that level by scrubbing out the net make of carbon dioxide on each pass (50). The gas is passed through the selective oxidation reactor 52 where substantially all of the hydrogen and the oxygen are combined to produce water. The reactor is fed with the gas at about 25° C. and the effluent leaves at about 175° C. owing to the heat of combustion. The gas is returned (24) to the freshly vaporized isobutane feed (20) to complete the cycle.

An alternative embodiment is illustrated in FIG. 3. The dehydrogenation of isobutane to isobutylene in reactor 32, followed by the oxidation of isobutylene to methacrolein in reactor 38 and the subsequent recovery of methacrolein are the same as on the flow sheet of FIG. 2. In this embodiment, all gases are purged and only unreacted isobutane and isobutylene are recycled for further production of methacrolein. This may be accomplished by absorbing the C₄ hydrocarbons by suitable liquid solvents such as paraffin or aromatic hydrocarbons, or solid materials such as molecular sieves. The method of FIG. 3 employs a liquid solvent selected to efficiently separate and recover isobutane and isobutylene from the other gaseous components. One economical solvent is a paraffin oil containing C₈-C₁₀ hydrocarbons. The recycle gas containing carbon oxides, hydrogen, oxygen, and light hydrocarbon by-products is passed into an absorber tower 54 where the isobutane, isobutylene, and heavier materials are absorbed by a liquid stream 56, leaving in the vapor phase the light gases, which are withdrawn (58) from the top of the column for recovery of useful components or disposal. The C₄-rich liquid is withdrawn from the bottom of the column 4 and passed (60) to stripping column 62 where the C₄'s are stripped out. The C₄-lean liquid is withdrawn from the bottom of the column 62, cooled in exchanger 64 and returned (56) to the absorber 54 for reuse. The vaporized isobutane and isobutylene are recycled (24) to the dehydrogenation reactor 32. A slipstream may be taken from the C₄-lean solvent and distilled to separate high-boiling materials in a conventional manner (not shown).

A typical example of the practical operation of the flow sheet shown in FIG. 3 is as follows:

EXAMPLE 4

One hundred mols/hr of a feed stream containing 95% isobutane is vaporized and fed (26) to the dehydrogenation reactor 32, along with 146 mols/hr of a recycle

11

gas stream (24) containing 62% isobutane and 38% isobutylene. The combined streams are heated and mixed with 461 mol/hr of steam (30) either as fresh steam or recycled from the methacrolein stripper 46 and vaporized. The combined stream 29 is fed to the dehydrogenation reactor 32 at about 650° C., where about 45% of the isobutane fed is converted to isobutylene. Leaving the reactor at about 520° C., the effluent stream is cooled to about 130° C. in exchanger 34 and mixed with 141 mol/hr of oxygen (36) before being supplied to the oxidation reactor 38, where about 82% of the isobutylene is converted to methacrolein. Leaving the reactor 38 at about 342° C. and 1.4 kg/cm² gauge the effluent gases are cooled to about 150° C. in exchanger 40 and passed to the absorber 42 where the methacrolein is recovered by a recirculating water stream (44) sufficient to produce an aqueous solution containing about 1-2 mol% methacrolein (45). This solution is then stripped in reboiled stripper 46 to produce a vapor side-stream product containing 69.7 mol/hr methacrolein, 6 mol/hr methacrylic acid and various by-products including acetic acid, acrolein, and acetone. The crude recycle gas (43) leaving the top of the absorber 42 is compressed (48) sufficiently to permit the gas to rejoin the fresh feed to the dehydrogenation reactor 32 (about 3.9 kg/cm² gauge). The 302 mol/hr vapor contains about 28% hydrogen, 7% oxygen, 30% isobutane, 19% isobutylene, and 11% carbon oxides. The gas is passed through the absorber tower 54 where substantially all of the isobutane and isobutylene are scrubbed out by stream 56 containing 150 mol/hr of C₈-C₁₀ solvent. The C₄-rich liquid (60) passes to the stripping column 62 where the C₄'s are stripped and are returned (24) to the dehydrogenation reactor 32 to complete the cycle.

As with the selective oxidation step previously discussed, the absorption of C₄'s by a solvent could be adapted to provide a partial separation of the effluent from the dehydrogenation step so that only isobutylene and unconverted isobutane are fed to the oxidation reactor. As before, some advantages are obtained, but at additional cost and it still remains necessary to remove oxygen and carbon oxides from the gaseous effluent.

What is claimed is:

1. A process for the preparation of methacrolein from isobutane comprising:

- (a) dehydrogenating isobutane to isobutylene [, optionally] in the presence of steam, over a dehydrogenation catalyst comprising a Group VIII noble metal [or base metal oxide] on a support at a temperature in the range of about 300°-700° C. and up to about 10 kg/cm² gauge pressure to form an effluent stream comprising isobutylene, hydrogen, carbon oxides, and unreacted isobutane;
- (b) mixing oxygen and optionally steam with said effluent stream of (a) and passing the mixture over a molybdenum-based oxidation catalyst at conditions selected to produce methacrolein and producing an effluent stream comprising methacrolein, unreacted isobutylene and isobutane, [and] oxygen, steam, and carbon oxides;
- (c) recovering the methacrolein from said effluent of (b);
- (d) separating from said effluent of (b) after recovery of methacrolein therefrom the hydrogen produced in (a), the carbon oxides produced in (a) and (b); and
- (e) returning as feed to (a) the effluent of (b) after recovering methacrolein, hydrogen, oxygen, and carbon oxides therefrom.

[2. The process of claim 1 further comprising the steps of:

12

(d) separating from said effluent of (b) after recovery of methacrolein therefrom the hydrogen produced in (a), the carbon oxides produced in (a) and (b); and

(e) returning as feed to (a) the effluent of (b) after recovering methacrolein, hydrogen, oxygen, and carbon oxides therefrom.]

3. The process of claim 1 wherein said dehydrogenation step (a) is fed with isobutane and steam in a ratio of about 1/1 to 1/10 and a pressure about 2-10 kg/cm² gauge.

4. The process of claim 1 wherein said oxidation step (b) is carried out at 300°-400° C. and 1-8 kg/cm² gauge.

5. The process of claim 1 wherein said oxidation catalyst of (b) comprises the elements molybdenum, bismuth, cobalt, iron, nickel, thallium, antimony, and one or more alkali metals.

6. The process of claim 1 wherein said oxygen and hydrogen are separated from said effluent of (b) after recovery of methacrolein therefrom by reaction to form water over an oxidation catalyst under conditions selected to oxidize said hydrogen while leaving said isobutylene and isobutane substantially unoxidized.

7. The process of claim 6 wherein said oxidation catalyst is platinum or palladium on alumina.

8. The process of claim 7 wherein said oxidation reaction is initiated at a temperature up to about 400° C.

9. The process of claim 6 wherein the amount of oxygen added in step (b) is adjusted to provide an amount in said effluent of (b) substantially equivalent to the hydrogen produced in (a).

10. [The process of claim 1 further comprising the steps of:] *A process for the preparation of methacrolein from isobutane comprising:*

(a) *dehydrogenating isobutane to isobutylene in the presence of steam, over a dehydrogenation catalyst comprising a Group VIII noble metal on a support at a temperature in the range of about 300°-700° C. and up to about 10 kg/cm² gauge pressure to form an effluent stream comprising isobutylene, hydrogen, carbon oxides, steam and unreacted isobutane;*

(b) *mixing oxygen and optionally steam with said effluent stream of (a) and passing the mixture over a molybdenum-based oxidation catalyst at conditions selected to produce methacrolein and producing an effluent stream comprising methacrolein, unreacted isobutylene and isobutane, oxygen, steam, and carbon oxides;*

(c) *recovering the methacrolein from said effluent of (b);*

(d) *separating from said effluent of (b) after recovery of methacrolein therefrom the unreacted isobutane and isobutylene by absorption in a liquid and thereafter stripping said absorbed isobutane and isobutylene from said liquid; and*

(e) *returning as feed to (a) the stripped isobutane and isobutylene from (d).*

11. The process of claim 10 wherein said liquid is a C₈-C₁₀ paraffin oil.

12. The process of claim 1 wherein the effluent of (a) is mixed with molecular oxygen and passed over an oxidation catalyst under conditions selected to selectively oxidize said hydrogen while leaving said isobutylene and isobutane substantially unoxidized and thereafter carrying out step (b).

13. The process of claim 12 wherein said oxidation catalyst is platinum or palladium on alumina.

14. The process of claim 13 wherein said selective oxidation reaction is initiated at a temperature up to about 400° C.

* * * * *