

[54] **METHOD FOR ELECTRICAL CONNECTION OF FLAT CABLES**

[75] Inventors: **Karl Weinmann, Watchung; Ted L. C. Kuo, Fanwood; Greenwood, William S., Nutley, all of N.J.**

[73] Assignee: **Thomas & Betts Corporation, Raritan, N.J.**

[21] Appl. No.: **287,463**

[22] Filed: **Jul. 27, 1981**

Related U.S. Patent Documents

Reissue of:

[64] Patent No.: **4,249,303**
 Issued: **Feb. 10, 1981**
 Appl. No.: **42,440**
 Filed: **May 25, 1979**

[51] Int. Cl.³ **H01R 43/00**
 [52] U.S. Cl. **29/868**
 [58] Field of Search **29/868; 339/17 F, 17 C, 339/17 E, 18 C, 97 R, 97 C; 174/68.5**

[56] **References Cited**

U.S. PATENT DOCUMENTS

2,613,287 10/1952 Geiger 339/17 E
 3,028,573 4/1962 Stoehr 339/17 E
 3,499,098 3/1970 McGahey et al. 174/68.5
 3,960,430 6/1976 Bunnell et al. .
 3,984,621 10/1976 Propst .
 4,002,393 1/1977 Merry et al. .
 4,030,801 6/1977 Bunnell .
 4,054,353 10/1977 Saunders et al. .

FOREIGN PATENT DOCUMENTS

2254395 5/1974 Fed. Rep. of Germany .
 940518 10/1963 United Kingdom 339/17 F

OTHER PUBLICATIONS

Electronic Design, Oct. 15, 1958, pp. 24-25, (Cable Connections The Easy Way).
 Marshall Space Flight Center-Spec. 494 A, Apr. 30, 1973, Superceding MSFC-Spec. 494.

NASA-Technical Memorandum TM-X-64887, Aug. 1974.

NASA SP-5120 Technology Utilization Program Report (Dec. 1974).

NASA-Technical Memorandum TM-X-64916, Mar. 1975.

Under Carpet Power & Communication Wire System, by J. Fleischhacker, Presented at 24th Intr. Wire & Cable Symposium, N.J., 11/18/75.

Tentative Interim Amendment to the 1978 National Electrical Code NFPA No. 70, Reference Article:328 Telephony, Jan. 8, 1979, Article by John W. Balde et al., A Better Way to Wire.

Building Design and Construction, Apr. 1979, pp. 26-29.

Publication "The Great Cover Up", Undated.

Publication "TUCC System", Undated.

Primary Examiner—Francis S. Husar

Assistant Examiner—Carl J. Arbes

Attorney, Agent, or Firm—Robert M. Rodrick; Salvatore J. Abbruzzese; Jesse Woldman

[57] **ABSTRACT**

In connecting flat multiconductor cables, one cable is placed atop another to provide a matrix of zones in which connections may be made of any conductor of one cable to any conductor of the other cable. Selection is made of one zone and it is perforated. An insulating-piercing connector is inserted through the perforation and crimped to provide an electrical connection between the pair of cable conductors in registry with the selected zone. Selection of further zones for perforation and connector insertion is made progressively from those zones which do not have in registry therewith any conductor which was in registry with any previously selected zone. Apparatus for implementing preferred connection zone selection precludes use of connecting zones other than a singular zone for connection of one conductor pair and compels use of a selective few zones individually for connection of respective other conductor pairs, thereby lessening connection error likelihood.

13 Claims, 9 Drawing Figures

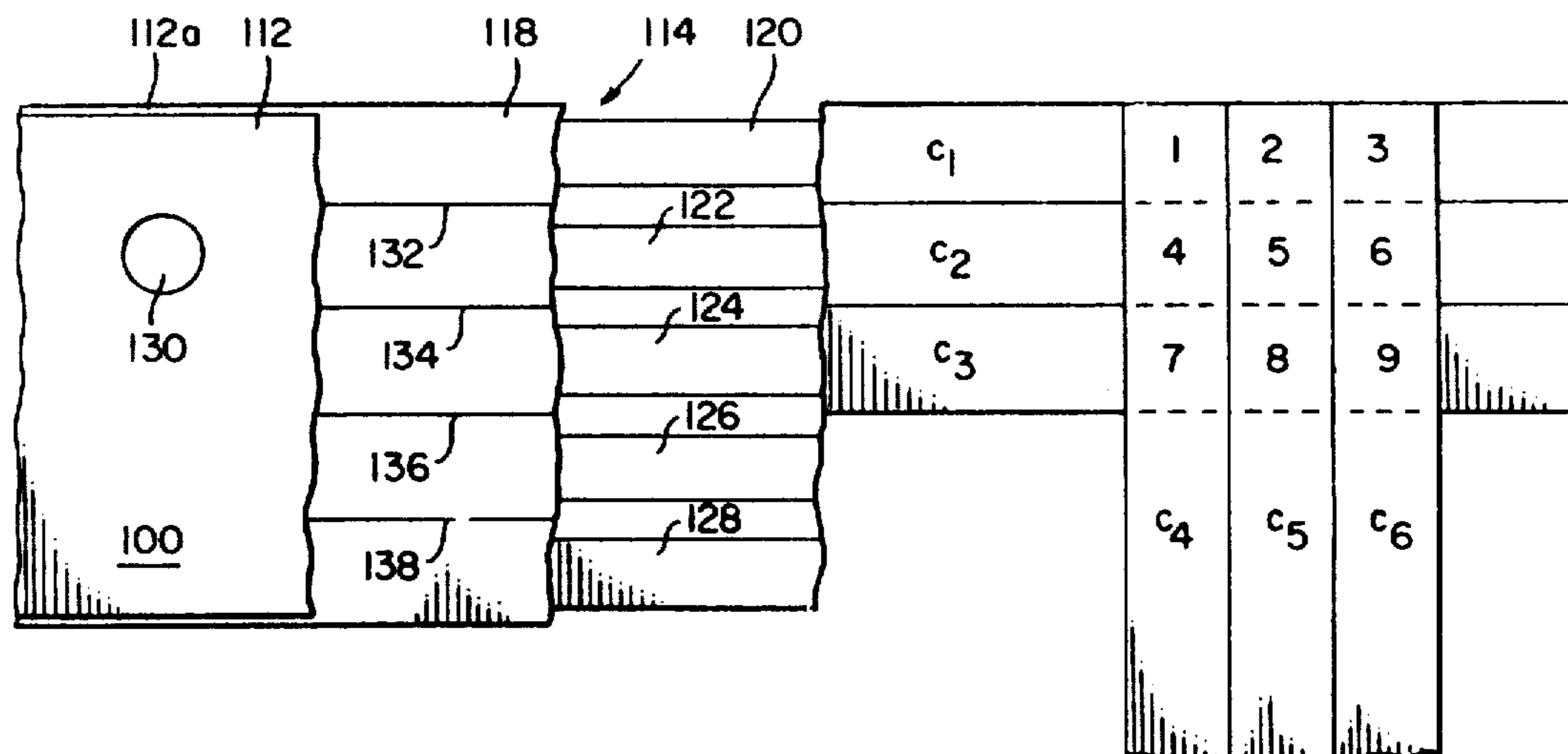

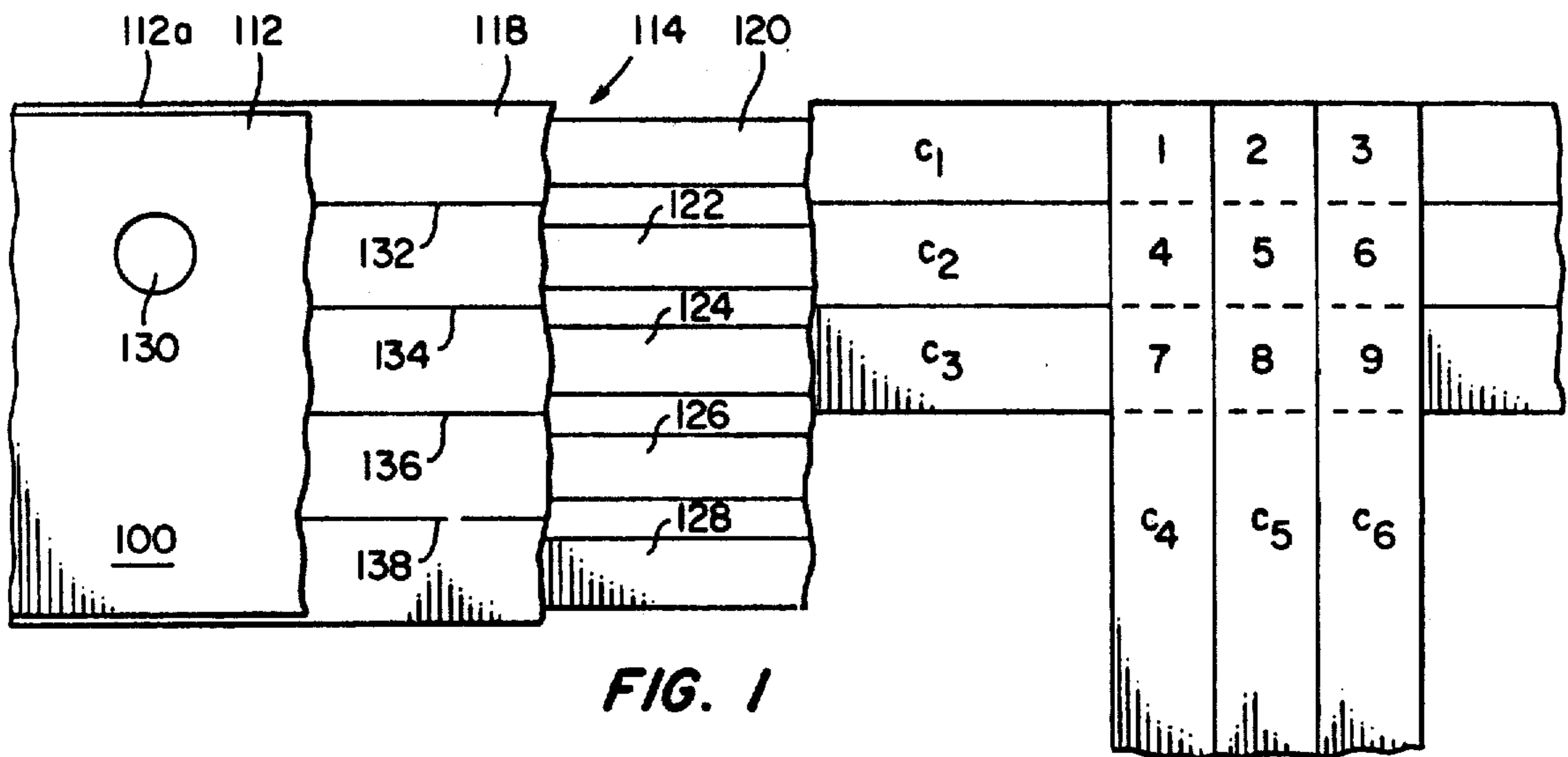

FIG. 1

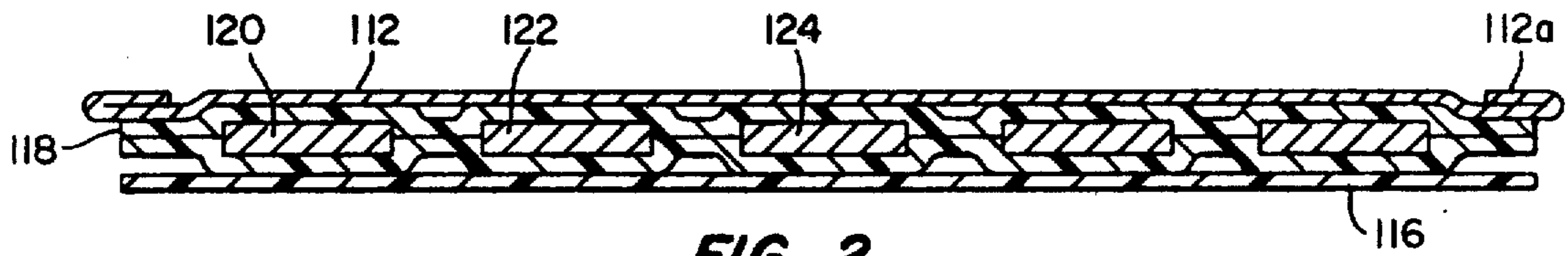

FIG. 2

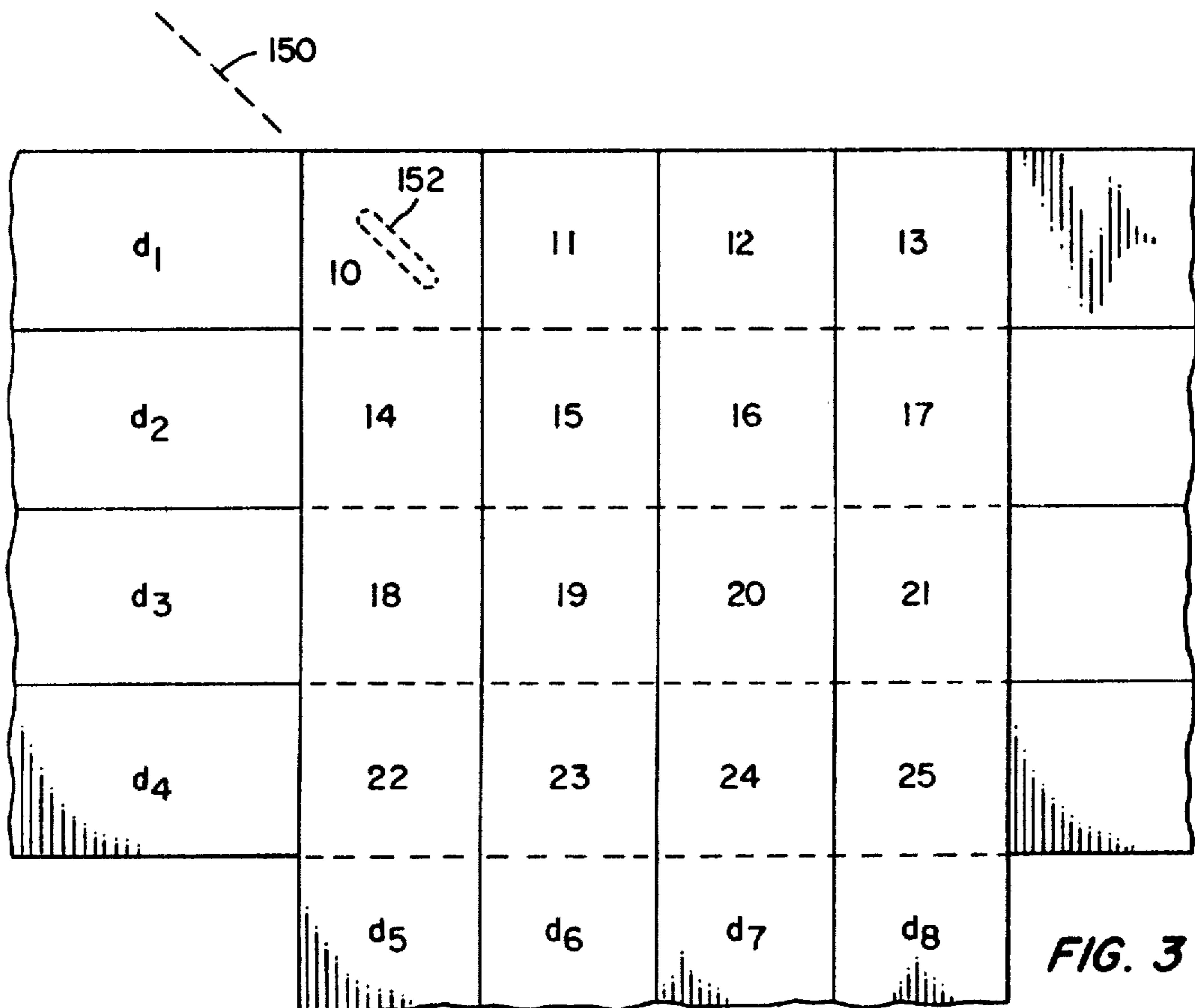

FIG. 3

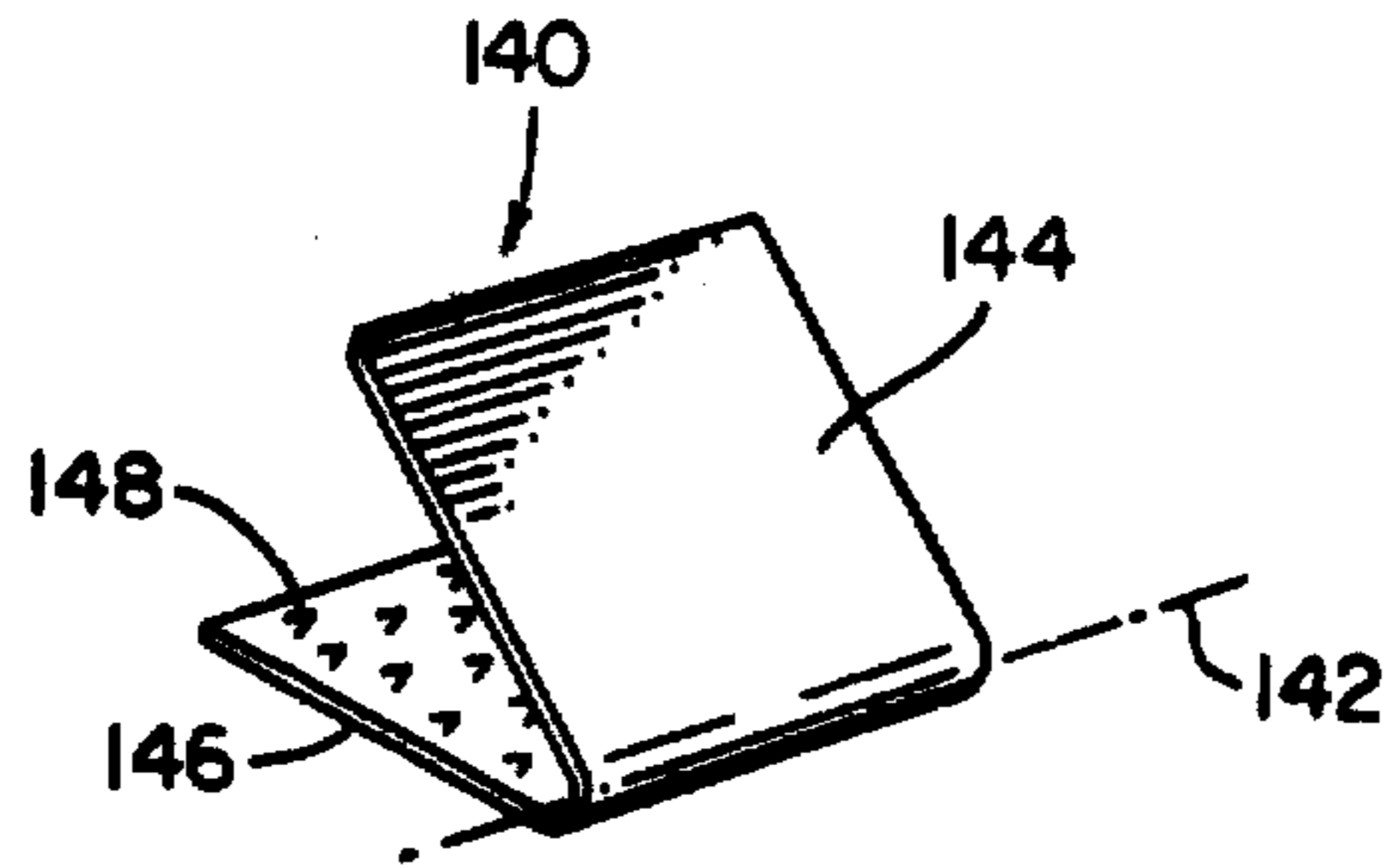

FIG. 5

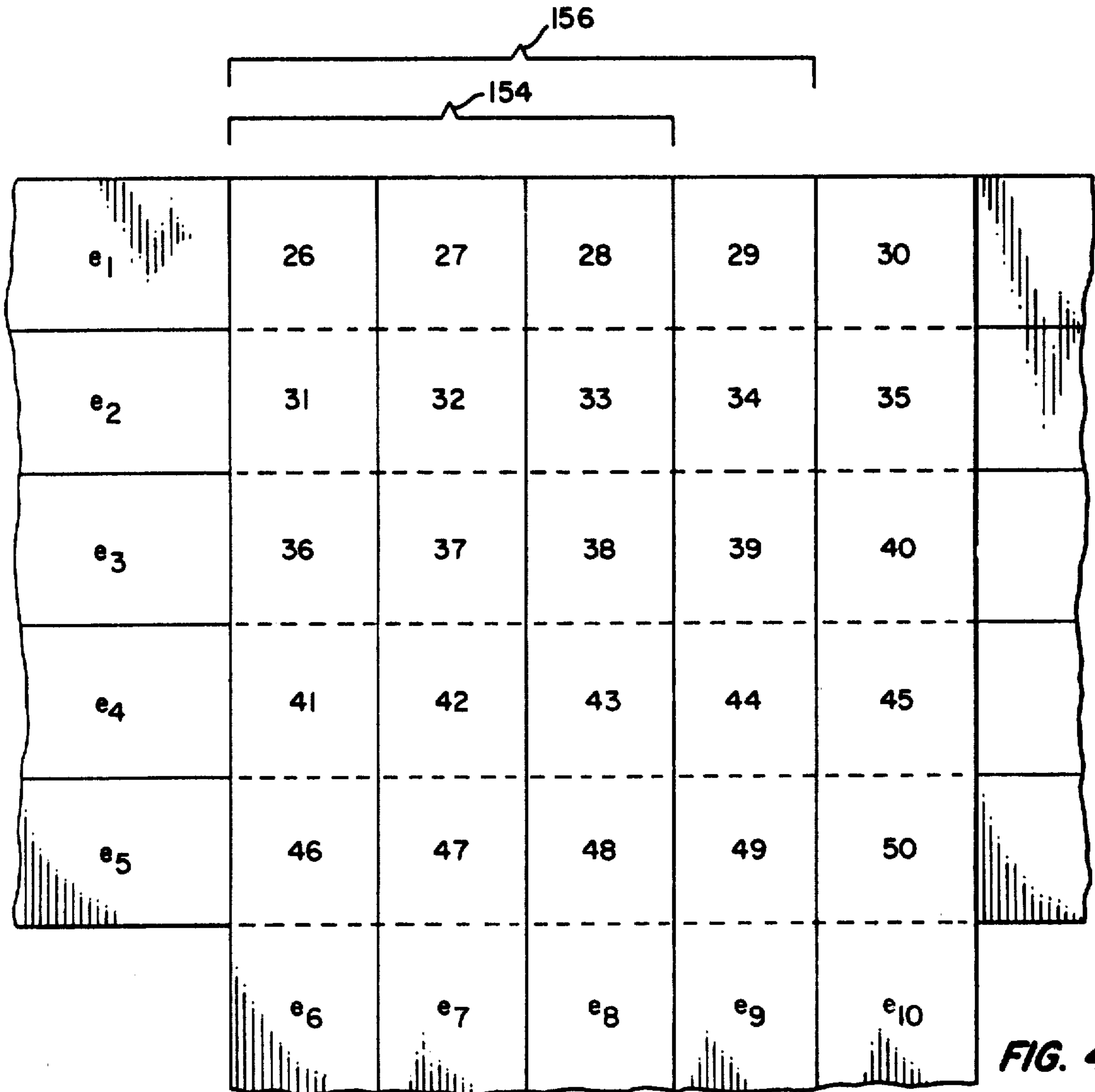
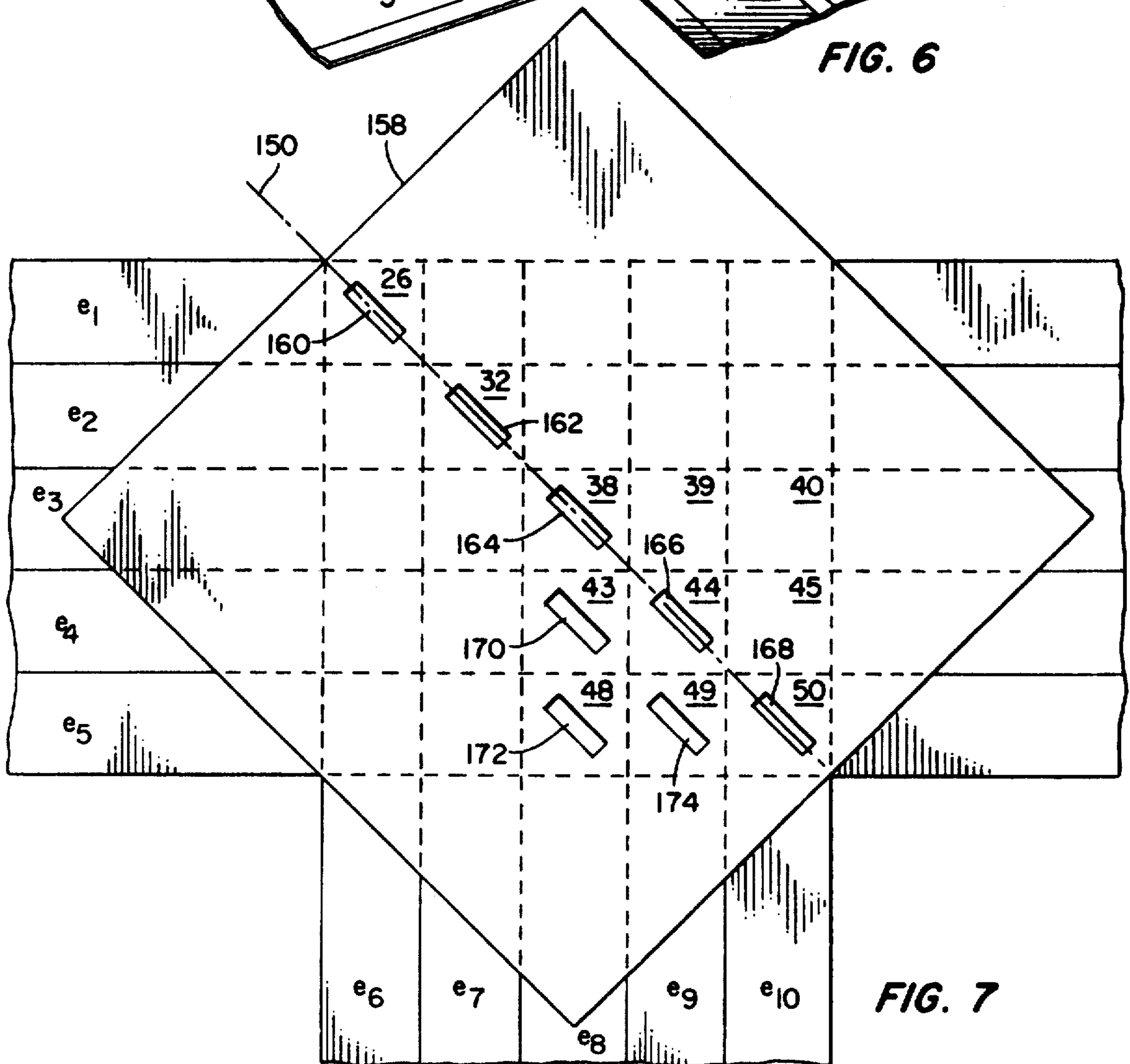
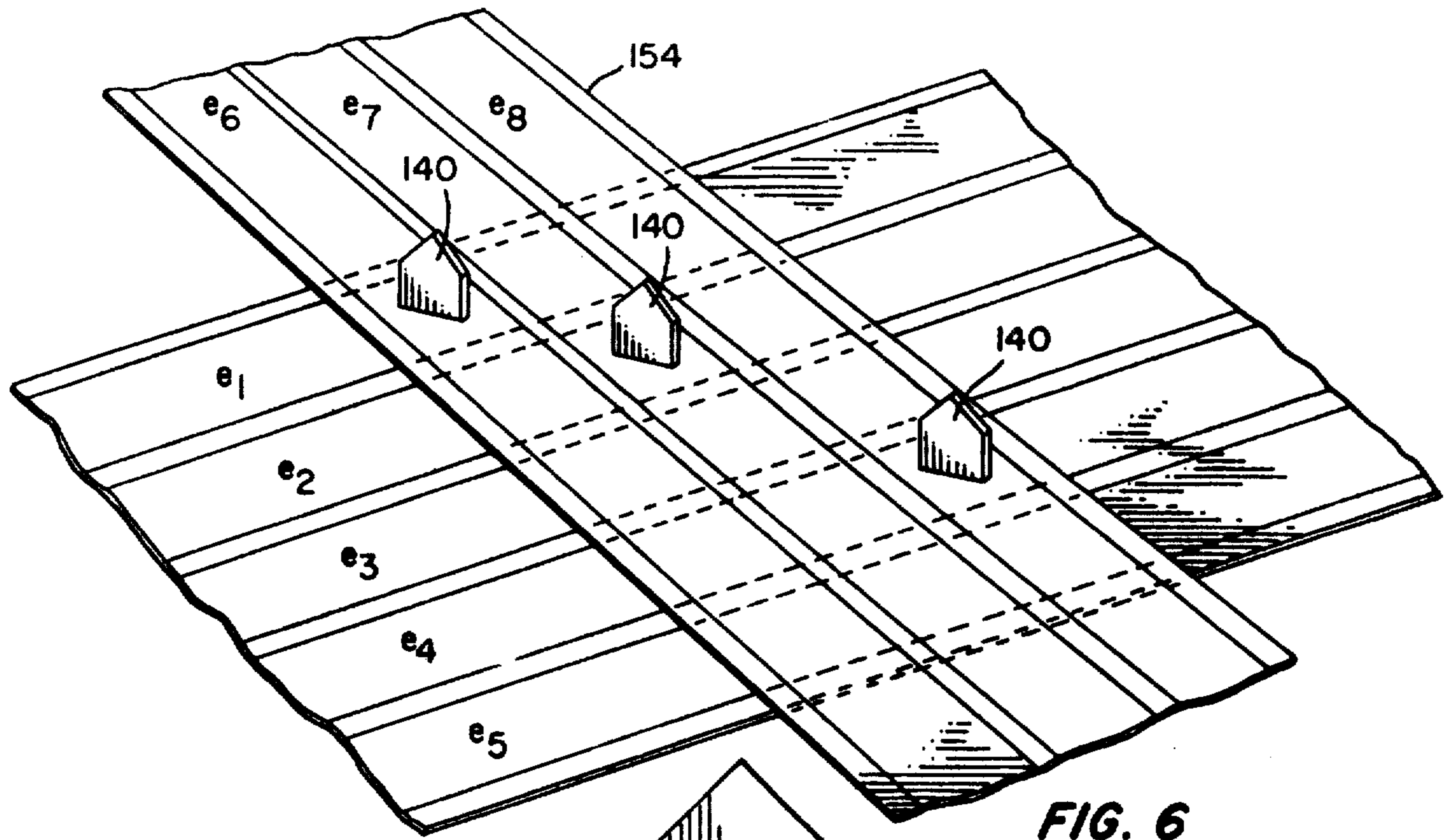
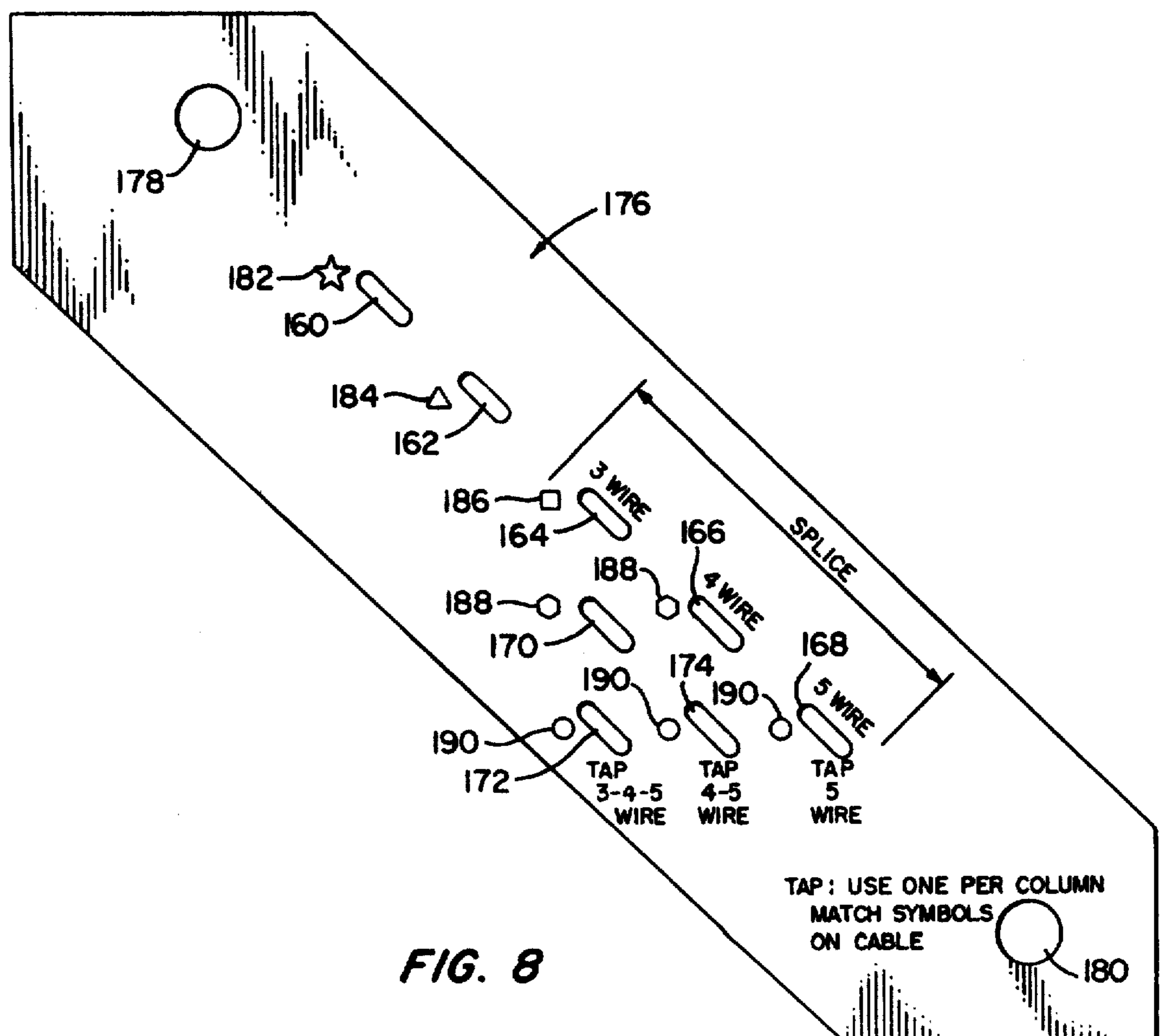
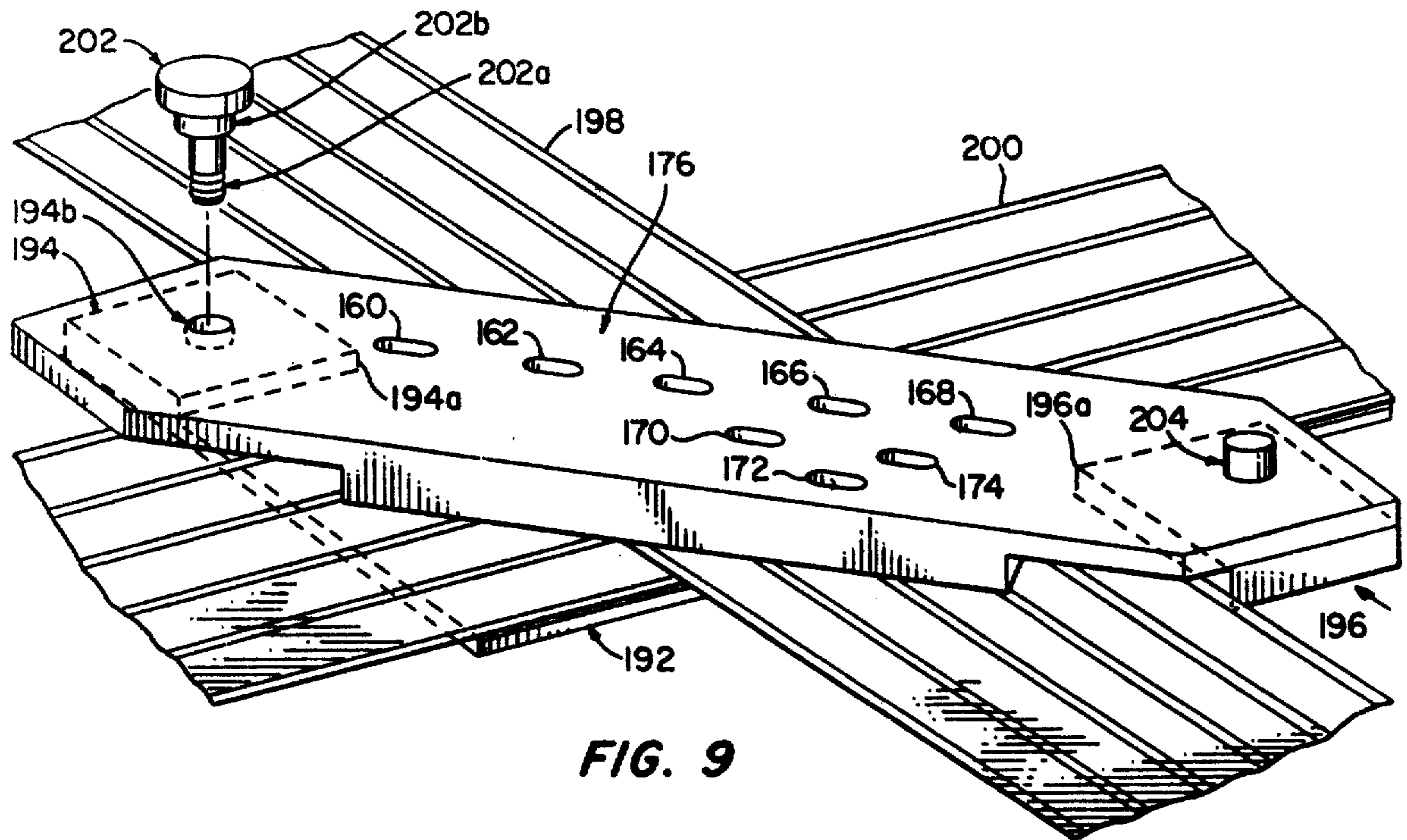

FIG. 4





METHOD FOR ELECTRICAL CONNECTION OF FLAT CABLES

Matter enclosed in heavy brackets [] appears in the original patent but forms no part of this reissue specification; matter printed in italics indicates the additions made by reissue.

FIELD OF THE INVENTION

The invention relates generally to methods and apparatus for the making of electrical connections and pertains, more particularly, to electrical interconnection of flat multiconductor cable in undercarpet use.

BACKGROUND OF THE INVENTION

In presently known undercarpet wiring systems, flat multiconductor cables to be connected are arranged either in respective longitudinal abutting relation for splices or in respective orthogonal abutting relation for taps. In the case of the splice, individual conductors are mutually aligned, whereby confusion as to conductors to be interconnected does not arise. An insulation displacing/piercing connector is simply positioned beneath the cable in alignment with each pair of conductors to be connected and is crimped therethrough. One conductor of one cable thus cannot readily be erroneously connected to plural conductors of the other cable.

In the case of tap connections, on the other hand, the possibility of installer confusion and error is quite real. Here, by reason of mutual orthogonality, each conductor of one cable runs in the direction of and may be connected to, all conductors of the other cable. Connection of one conductor of one cable to plural conductors of the other cable can readily arise.

Such confusion is inherently eliminated by use of a unique length connector for each connection to be made. However, this practice requires as many as five unique length connectors to be available, i.e., for a three-phase tap with neutral and ground carried through, and requires proper installer selection of unique length connectors. Apart from these matters, this type of connecting practice has disadvantage in that all connectors, except for the shortest length one, span plural conductors of one of the cables, thereby providing the potential for interphase short circuit.

In the undercarpet wiring system adopted by the assignee of the subject application, described and set forth in copending commonly-assigned applications Ser. Nos. 42,369 and 42,544, respectively entitled "Multi-conductor Cable Arrangement and Electrical Connection" and "Multiconductor Cable", cables to be interconnected are placed in mutually overlapping relation, as contrasted with the above-noted mutually abutting relation. In such overlapping arrangement, a matrix of possible connection zones is presented. For example, in a three-conductor to three-conductor tap, nine zones are in the overlap area, each zone presenting a unique pair of conductors for possible connection. Those conductor pairs to be connected are perforated and an insulation displacing/piercing connector is inserted through the perforation and is crimped onto those cable surfaces exterior to the overlap. A common-sized connector is used throughout and has no expanse, when crimped, which extends outwardly of the connection zone involved. There is thus no need for diverse-sized connectors at installation and no need for care in connector selection by an installer. Since the connectors do

not span plural conductors of one cable, short-circuiting possibility, arising from an individual connector, is diminished. These advantages are seemingly set off, however, by a loss of the advantage inherent in the use of different-sized connectors and noted above, i.e., a lessening of the possibility of the connection of one conductor of one cable to plural conductors of the other cable.

SUMMARY OF THE INVENTION

This invention has as its object the provision of improved methods for the electrical interconnection of multiconductor cables.

It is a more particular object of the invention to provide methods for use in the electrical interconnection of mutually overlapped flat multi-conductor cables.

In attaining the foregoing and other objects, the subject invention provides practice wherein multi-conductor cables, arranged in mutual overlapping relation and presenting the foregoing connection zone matrix, are electrically connected by selecting one zone as an origin connection location and by selecting further connection zones progressively from the groups of zones which do not have in registry therewith any conductor in registry with any previously selected zone. The selected zones are perforated and connectors inserted through the perforations for making electrical connections between conductors in registry with the selected zones.

The foregoing and other features of the invention will be further evident from the following detailed description of preferred embodiments and from the drawings wherein like reference numerals identify like parts throughout.

DESCRIPTION OF THE DRAWINGS

FIG. 1 is a plan view showing, in its left-ward portion, a multiconductor cable with overlying shield, and in its rightward portion, a pair of three-conductor cables in overlapping relation.

FIG. 2 is a section view taken to the left of weldment 130 of FIG. 1.

FIGS. 3 and 4 are plan views of pairs of four- and five-conductor cables in overlapping relation.

FIG. 5 is a perspective view of a type of connector suitable for use in practicing the invention.

FIG. 6 is a perspective view of a five-to-three conductor tap with connectors of FIG. 5 type in tap-securing but uncrimped condition.

FIG. 7 is a schematic illustration of a connection guide overlying a pair of overlapped five-conductor cables.

FIG. 8 is a plan view of a preferred embodiment of a connection guide of the invention.

FIG. 9 is a perspective view showing the connection guide of FIG. 8 in operative disposition relative to a base therefor and a pair of overlapped five-conductor cables.

DESCRIPTION OF PREFERRED PRACTICES AND EMBODIMENTS

Referring to FIGS. 1 and 2, cable assembly 100 includes an overlying shield 112, comprised of electrically conductive sheet material, a multiconductor cable 114 and underlying plastic sheet 116. Cable 114 has an electrically insulative casing 118 formed of opposed plastic sheets which envelop flat electrical conductors 120, 122, 124, 126 and 128. Shield 112 is joined to the grounding conductor 122 of cable 114 as by weldments

130, mutually spaced along the cable length, as more fully set forth in the above-identified commonly-assigned U.S. patent applications. Prior to securement of shield 112 to cable 114, the cable may be reduced from the five-conductor cable, shown at the left in FIG. 1, to a four-conductor cable, or to a three-conductor cable, shown at the right in FIG. 1, by separating individual or plural conductors along lines 132, 134 or 136.

Considering the right-hand portion of FIG. 1, a tap connection arrangement is shown wherein conductors 120, 122 and 124 (further denoted as c_1 , c_2 and c_3) underlie another three-conductor cable having conductors c_4 , c_5 and c_6 . The mutual overlap area defines a matrix of nine possible connection zones, identified as 1 through 9, each such zone being uniquely characterized by having a singular pair of conductors c_1 - c_6 in registry therewith. Thus, zone 1 has only conductors c_1 and c_4 in registration, zone 2 has only conductors c_1 and c_5 , etc.

In this example n objects are presented for combination in sets of x , where n is the number of conductors (six) and x is the number of electrical connections (three) to be made. Since permutations are not relevant (zones 1, 5, 9 provide the same result as 9, 5, 1 and 5, 1, 9, etc.), they are not considered. The number of possible combinations is $n!/x!(n-x)!$, or twenty combinations. Of these twenty possible combinations, only six are usable to provide connections of c_1 - c_3 to c_4 - c_6 , as in the following table:

TABLE 1

Combination	Connections	Zones
I	c_1c_4, c_2c_5, c_3c_6	1-5-9
II	c_1c_6, c_2c_5, c_3c_4	3-5-7
III	c_1c_4, c_2c_6, c_3c_5	1-6-8
IV	c_1c_5, c_2c_6, c_3c_4	2-6-7
V	c_1c_6, c_3c_5, c_2c_4	3-8-4
VI	c_1c_5, c_2c_4, c_3c_6	2-4-9

The remaining fourteen possible combinations will lead to electrical connection error. By way of example, the combination of connections c_1c_2, c_3c_4, c_5c_6 is manifestly not usable and would yield interphase short-circuiting.

In FIG. 3, a four-conductor to four-conductor tap has conductors d_1 through d_8 . The connection zone matrix has sixteen registration zones, i.e., zones 10-25. With n now eight and x now four, the number of possible combinations for connection are $8!/4!(8-4)!$, or seventy. Of these, only twenty-four are usable to provide connection of $[d_4-d_4] d_1-d_4$ to d_5-d_9 .

In FIG. 4, a five-conductor of five-conductor tap has conductors e_1 through e_{10} . The connection zone matrix has twenty-five registration zones, i.e., zones 26-50. With n now ten and x now five, the possible combinations number $10!/5!(10-5)!$, or two hundred fifty-two. Ninety thereof are usable to provide connection of e_1-e_5 to e_6-e_{10} .

As is made evident by the foregoing discussion of FIGS. 1-3, an installer of flat cables in overlapping manner is faced with a plethora of possible connections and a correspondingly high risk of installation error. The present invention looks to the provision of methods for selecting connection patterns from those available, lessening error risk and making cable installation less judgemental to the installer.

In one such method, selection is made at the outset of an origin location for a pattern. For example, in a four-four tap of d_1-d_8 (FIG. 3), zone 10 may be made the origin location and conductors d_1 and d_5 are therein provided with registering perforations. Selection is now

made of a second connection location from those connection locations comprising all zones not having registered therewith either of the conductors registered with the origin location, i.e., in the example of FIG. 3, zones 15-17, 19-21, and 23-25. Zone 15 is selected for discussion purposes and conductors d_2 and d_6 are therein provided with registering perforations. The selection of a third connection location is now made from those connection locations comprising all zones not having registered therewith any of the conductors registered with the origin, and second locations, i.e., in the example of FIG. 3, zones 20, 21, 24 and 25. If zone 20 is selected, then zone 25 is the fourth connection location. If zone 21 is selected as the third connection location, then zone 24 is the fourth connection location. Assuming zones 20 and 25 to have been selected, perforations are made in zone 20 through conductors d_3 and d_7 and in zone 25 through d_4 and d_8 . Connectors are now inserted through the perforations in the selected connection locations and crimped onto the outer surfaces of the cables.

In FIG. 5, connector 140 is shown in open condition, partially bent about axis 142 to define portions 144 and 146, each having insulation piercing teeth 148. The connection location geometry in FIG. 4, selected in the example, is diagonal 150 and the perforations are elongate slots 152 along diagonal 150. Portion 144 or 146 is inserted into the slot until bend axis 142 is within the slot. The connector is then rotated about its bend axis to place teeth 148 in facing relation to the outer surfaces of the cables. All connectors may be so placed in position without crimping until a final check of the tap connection is made. The connectors are then crimped in place, teeth 148 thereupon being electrically connected to the underlying conductors and mechanically fixed in place.

The method set forth for three-three, four-four and five-five conductor taps is equally applicable to provide correctness in taps between cables having different numbers of conductors. Referring again to FIG. 4, a three-conductor cable 154 having conductors e_6, e_7 and e_8 is to be tapped to the cable having conductors e_1-e_5 . Assignment is made of e_1 as the neutral conductor of a three-phase power line, e_2 as the ground conductor, and e_3-e_5 phases A, B and C, respectively. In conforming order, i.e., polarizing cable 154 to the e_1 assignment, the connection origin is selected to be location 26 whereby e_6 will be the neutral conductor of cable 154. Of the connection location group available for remaining connections, i.e., zones 32, 33, 37, 38, 42, 43, 47 and 48, zone 32 is selected to connect conductor e_7 to ground conductor e_2 .

Choice is now open to the system installer or designer, for load balancing or phasing purposes, of remnant available connection zones 38, 43 and 48, i.e., those zones which do not have in registry therewith any of conductors e_1, e_2, e_6 and e_7 . Whichever zone is selected, no further connection zones remain available, since conductor e_8 is in registry with all of zones 38, 43 and 48, thereby excluding those unselected zones from further use. Where either zone 43 or 48 is selected, connection pattern geometry now departs from complete diagonal. FIG. 6 depicts the assembly reached by selection of zone 43, with uncrimped connectors in place.

Cable 156 of FIG. 4 includes four conductors e_6-e_9 and may be connected to the e_1-e_5 cable as follows. Where polarization is desired, connections are again made in zones 26 and 32 for e_1, e_6 and e_2, e_7 , respec-

tively, now leaving six zones 38, 39, 43, 44, 48 and 49 for the making of the two phase connections. Assuming zone 48 to be chosen for conductor e₈, i.e., phase C, there remain only zones 39 and 44 for conductor e₉ with corresponding choice of phase A or phase B. Again, no connection zones remain under the foregoing method, once this last-noted choice is made.

In preferred practice, installer assistance is enhanced over that generally afforded by the above methods, by imposing predetermined geometry for the making of connections. In this practice, polarization is applied to first and second adjacent connections of any set of connections and such adjacent connections are invariably made. The foregoing general methods is limited to these connections and selection of further connections is biased or compelled by use of a connection guide in the form of a template or stencil having apertures or slots in predetermined pattern, such as is shown in FIG. 7.

Referring to FIG. 7, a stencil or plate member 158 is arranged in overlying relation to mutually orthogonal cables e₁-e₅ and e₆-e₁₀. Slot 160 is arranged along axis 150 in registry with zone 26. When an installer arranges the stencil and outlines a prospective cable aperture by use of slot 160, he precludes possible connection of conductors e₁ and e₆ to any other conductors. Slot 162, adjacent to slot 160 along axis 150 is in registry with zone 32. When an installer outlines a cable connection by use of slot 162, he compels interconnection of cables e₂ and e₇ and precludes connection of these two conductors to any other conductors. As for conductor e₃, stencil 158 permits but a single connection, i.e., to conductor e₈. This arrangement forces distribution of phase A through conductors e₃ and e₈. Since slots are not included in registry with zones 39 and 40, erroneous, redundant phase A connections are precluded. On the other hand, by inclusion of slots 170 and 172, in registry with zones 43 and 48, the stencil permits the routing of B phase or C phase to conductor e₈.

In the case of conductor e₄, stencil 158 does not include a slot in registry with zone 45, having slot 170 in registration with zone 43 and slot 166 in registration with zone 44. The stencil thus biases distribution of B phase to either conductor e₈, as noted above, or conductor e₉, accordingly reducing the possibility of erroneous, redundant connection to conductor e₄ by such omission of zone 45.

By inclusion of slots 172, 174 and 168 in respective registration with zones 48, 49 and 50, the stencil 158 permits distribution of C phase from conductor e₅ to any of conductors e₈, e₉ and e₁₀. The pattern geometry selected in FIG. 7 is such that all of slots 160-168 are aligned along axis 150, which is the diagonal of the connection matrix common to the two multiconductor cables. Slots 170 and 174 are aligned along a first axis parallel to axis 150 and slot 172 is aligned along a second axis parallel to axis 150.

The limited error connection possibility resident in stencil 158 of FIG. 7 is further diminished by reliance on identifying indicia on both cables and stencil, as is developed in the apparatus shown in FIGS. 8 and 9. In FIG. 8, a plate member 176 incorporates slots 160-174 in identical pattern with that of stencil 158 in FIG. 7. Registration holes 178 and 180 are provided at ends of plate 176 and the plate includes discriminating indicia 182, in the form of a star, 184, in the form of a triangle, 186, in the form of a square, 188, in the form of a hexagon, and 190, in the form of a circle. Conductors e₁ through e₅ and conductors e₆ through e₁₀ (FIG. 7) bear

corresponding indicia. Additionally, plate 176 bears literal indications adjacent various slots. The term "SPLICE" encompasses slots 164, 166 and 168 and the slots respectively bear terms "3 WIRE", "4 WIRE" and "5 WIRE". Under the vertical column including slots 164, 170 and 172, the plate bears the legend "TAP 3-4-5 WIRE". The vertical column including slots 166 and 174 bears the legend "TAP 4-5 WIRE". Beneath slot 168 is the legend "TAP 5 WIRE". Adjacent hole 180 is the legend "TAP: USE ONE PER COLUMN MATCH SYMBOLS ON CABLE".

As noted above, cable markings are invariably made through slots 160 and 162. In the case of a splice, i.e., connection of two longitudinally aligned and overlapping cables, slots 164-168 are used depending upon the number of wires in the conductors.

In the case of a tap, i.e., connection of two cables in overlapping and orthogonal relation, all slots may be used. Proper connections and maintenance of polarity is assured by simple recognition of the indicia. Each indicium is uniquely colored to further facilitate proper connections. Table 2 indicates the various connection possibilities achievable.

TABLE 2

Slots	Connection(s) Achieved
160, 162 and 164	three conductor cable to three conductor cable splice (phase A) three conductor cable to three, four or five conductor cable tap (phase A)
160, 162, 164 and 166	four conductor cable to four conductor cable splice (phases A and B) four conductor cable to four or five conductor cable tap (phases A and B)
160, 162, 164, 166 and 168	five conductor cable to five conductor cable splice (three phase) five conductor cable to five conductor cable tap (three phase)
160, 162 and 170	three conductor cable to four or five conductor cable tap (phase B)
160, 162 and 172	three conductor cable to five conductor cable tap (phase C)
160, 162, 170 and 174	four conductor cable to five conductor cable tap (phases B and C)
160, 162, 164 and 174	four conductor cable to five conductor cable tap (phases A and C)

In FIG. 9, plate 176 is shown with cooperative structure providing therewith an installation tool. For convenience, the literal legends and indicia are omitted, but would be included in the device. Base 192 is formed with upwardly extending cable guides 194 and 196, which receive cables 198 and 200 and place the cables in proper orientation with respect to the slot pattern in plate 176. Thus, the cables are made mutually orthogonal and slots 160-168 register with a line extending between edge corners 194a and 196a of guides 194 and 196. Guide 194 has a threaded bore 194b for receipt of pin 202 having threaded end 202a and shoulder 202b. Pin 204 may be fixedly secured to guide 196 to serve as a pivot for movement of plate 176 into operative position whereupon pin 202 is threaded into guide 194.

In the FIG. 9 arrangement, base 192 preferably functions as a die and has slots in its upper surface in pattern and configuration conforming with the slots 160-174 of plate 176. To perforate the cables a punch or punches would be inserted in the guide holes in plate 176 in the positions which provide the proper perforations for the connection to be made. Application of an appropriate force or forces to the punch or punches would then

create the desired perforation pattern in the cables. Base 192 preferably includes a removable tray for collection of matter thus punched out of the cables. Connectors of type shown in FIG. 6 would then be inserted and crimped to complete the connection.

In preferred practice, the stencil indicia are colored as follows: 182 white; 184 green; 186 black; 188 red; and 190 orange. Cable insulation over conductors is correspondingly colored, e.g., for a five-conductor cable: neutral—white; ground—green; phase A—black; phase B—red; and phase C—orange.

As will be seen, practice wherein neutral and ground connections are in respective singular connection zones of the matrix of connection zones results in repetitive selection of neutral and ground connection zones, i.e., identical geometry in separate connections of a first pair and a second pair of cables, thus carrying polarization throughout an entire installed system. This practice may be restricted to connection of a single pair of conductors to a specific repetitive zone, e.g., an outermost conductor of each cable. While mutual orthogonality of cables is preferred, other alignment is within the purview of the invention. Also, zone selection pattern may be other than a diagonal of the matrix; as noted in Table I for a three-three matrix.

In the aspect of the foregoing disclosure wherein connection guiding is by stencil or the like, far less than all of the connection zones of the matrix are employable. Connection of at least one pair of conductors is effected by preclusion of use of zones other than a singular zone. In this case, the connection guide has an aperture in registry with such singular zone and continuous surface expanse extending in directions mutually perpendicular from such aperture. Connection of at least one other conductor pairs is compelled to less than all zones with which such conductors are in registry. In this case, the connection guide has plural apertures in registry with a common conductor of a cable, i.e., along an axis parallel to the conductors of one cable and orthogonal to the conductors of the other cable where the guide arranges the cables in mutually orthogonal relation.

Various changes to the foregoing, specifically disclosed embodiments and practices will be evident to those skilled in the art. Accordingly, the foregoing preferred embodiments are intended in an illustrative and not in a limiting sense. The true spirit and scope of the invention is set forth in the following claims.

We claim:

1. A method for interconnection of flat multiconductor cables, comprising the steps of:
 - (a) placing one such cable in overlying relation to another such cable in manner providing a matrix of connection zones wherein each zone has a unique pair of cable conductors in registry therewith;
 - (b) selecting an origin connection zone having in registry therewith first conductors of said cables and precluding from connection use all other zones in registry with said first conductors;
 - (c) perforating said first conductors at said origin zone and making electrical connection therebetween;
 - (d) providing for selection plural zones in registry with a second conductor of one of said cables and precluding from connection use all other zones in registry with said second conductor.
 - (d) providing for selection first plural zones in registry with a second conductor of one of said cables said first

plural zones being less than all zones in registry with such one cable second conductor, and providing second plural zones in registry with a third conductor of such one cable and thereby distinct from said first plural zones, said second plural zones being less than all such zones in registry with such one cable third conductor, one zone of each of said first plural zones and said second plural zones being in registry with a common conductor of the other of said cables, and precluding from connection use other zones in registry with said second and third conductors of such one cable; and

- (e) selecting further zones for perforation and connection of conductors until connections are made to all conductors of at least one of said cables, each such further zone being selected [from the group] such first and second pluralities of zones and other zones which do not have in registry therewith any conductor in registry with any previously selected zone.

2. The method of claimed in claim 1 wherein said step (e) is practiced by selecting for connection a zone adjacent said origin zone and having in registry therewith [third] fourth conductors of said cables and precluding from connection use all other zones in registry with said [third] fourth conductors, perforating said [third] fourth conductors at such adjacent zone and making electrical connection therebetween.

3. The method claimed in claim 1 wherein said step (a) is further practiced by disposing said first and second cables in mutually orthogonal relation.

4. The method claimed in claim 1 wherein said steps (b) and (c) are practiced by conforming such selection therein to a pattern having predetermined geometry in said matrix.

5. The method claimed in claim 1 wherein said step (a) is further practiced by disposing said first and second cables in mutually orthogonal relation and wherein said steps (b) and (c) are practiced by conforming such selection therein to a pattern having predetermined geometry in said matrix.

6. The method claimed in claim 5 wherein said predetermined geometry comprises a diagonal of said matrix and wherein first, second and third of said selected connection [locations] zones are disposed along said diagonal.

7. A method for interconnecting flat multiconductor cables, comprising the steps of:

- (a) providing a first cable having a given number of conductors and a second cable having at least one conductor more than said given number;
- (b) placing said first cable in overlying relation to said second cable in manner providing a matrix of connection zones wherein each zone has a unique pair of cable conductors in registry therewith;
- (c) selecting an origin connection zone having in registry therewith a first conductor of each of said first and second cables and precluding from connection use all other zones in registry with said first conductors;
- (d) perforating said first conductors at said origin zone and making electrical connection therebetween;
- (e) selecting a further connection zone having in registry therewith a second conductor of each of said first and second cables and precluding from connection use all other zones in registry with said second conductors;
- (f) perforating said second conductors at said further zone and making electrical connection therebetween;

- (g) providing for selection plural zones in registry with a third conductor of said second cable and precluding from connection use all other zones in registry with said second cable third conductor; and
 - (h) perforating conductors of said first and second cables in registry with a selected one of said plural zones and making electrical connection therebetween until connections are made to all conductors of said first cable, whereby said first cable is connected to said second cable without interconnecting to one another conductors common to said first cable or common to said second cable.
8. The method claimed in claim 7 wherein said step (a) is practiced in part by providing plural conductors of said second cable with distinct phase assignments and wherein such selection in said step (h) is practiced to effect a selected phase interconnection between said first and second cables.
9. The method of claim 8 wherein said step (a) is practiced by providing said first cable with three conductors and said second cable with four conductors, and by assigning the third and fourth of said second cable conductors respectively to A phase and B phase, and wherein said step (h) is practiced to effect A phase interconnection between said first and second cables.
10. The method claimed in claim 8 wherein said step (a) is practiced by providing said first cable with three conduc-

- tors and said second cable with four conductors, and by assigning the third and fourth of said second cable conductors respectively to A phase and B phase, and wherein said step (h) is practiced to effect B phase interconnection between said first and second cables.
11. The method claimed in claim 8 wherein said step (a) is practiced by providing said first cable with three conductors and said second cable with five conductors, and by assigning the third, fourth and fifth of said second cable conductors respectively to A phase, B phase, and C phase and wherein said step (h) is practiced to effect A phase interconnection between said first and second cables.
12. The method claimed in claim 8 wherein said step (a) is practiced by providing said first cable with three conductors and said second cable with five conductors, and by assigning the third, fourth and fifth of said second cable conductors respectively to A phase, B phase, and C phase and wherein said step (h) is practiced to effect B phase interconnection between said first and second cables.
13. The method claimed in claim 8 wherein said step (a) is practiced by providing said first cable with three conductors and said second cable with five conductors, and by assigning the third, fourth and fifth of said second cable conductors respectively to A phase, B phase, and C phase and wherein said step (h) is practiced to effect C phase interconnection between said first and second cables.
- * * * * *

30

35

40

45

50

55

60

65

UNITED STATES PATENT AND TRADEMARK OFFICE
CERTIFICATE OF CORRECTION

PATENT NO. : Re. 31,336
DATED : August 9, 1983
INVENTOR(S) : Karl Weinmann et al

It is certified that error appears in the above-identified patent and that said Letters Patent is hereby corrected as shown below:

In Claim 1, Column 7, line 68, after the italicized word "cables" insert a comma -- , --.

In Claim 1, Column 8, line 16, after "group]" insert the italicized word -- from --.

In Claim 2, Column 8, line 21, "of" should be deleted.

In Claim 9, Column 9, line 19, "of" should be deleted and -- claimed in -- inserted therefor.

In Claim 10, Column 10, lines 4-5, the words "is practiced to effect B phase interconnection between said first and second cables." should be italicized.

Signed and Sealed this

Eighth Day of November 1983

[SEAL]

Attest:

GERALD J. MOSSINGHOFF

Attesting Officer

Commissioner of Patents and Trademarks

UNITED STATES PATENT AND TRADEMARK OFFICE
CERTIFICATE OF CORRECTION

PATENT NO. : Re. 31,336

DATED : August 9, 1983

INVENTOR(S) : Karl Weinmann, Ted L. C. Kuo, William S. Greenwood

It is certified that error appears in the above-identified patent and that said Letters Patent is hereby corrected as shown below:

In Claim 7, column 9, line 2, the word "second" should read
-- first --;

In Claim 7, column 9, line 4, the word "second" should read
-- first --.

Signed and Sealed this

Twenty-fourth **Day of** *September 1985*

[SEAL]

Attest:

Attesting Officer

DONALD J. QUIGG

*Commissioner of Patents and
Trademarks—Designate*