

[54] **SIGNAL MODIFICATION DEVICE FOR MEMORY CONTROLLED MANIPULATOR APPARATUS**

[75] Inventor: **Takehiko Watanabe, Akashi, Japan**

[73] Assignee: **Unimation, Inc., Danbury, Conn.**

[21] Appl. No.: **33,482**

[22] Filed: **Apr. 26, 1979**

3,917,930	11/1975	Davey et al.	318/632
3,943,343	3/1976	Irie	318/568
3,974,432	8/1976	Thompson	318/569
4,140,953	2/1979	Dunne	318/568

OTHER PUBLICATIONS

"Direct Memory Access and Automatic Block Transfers", *Minicomputers for Engineers and Scientists*, 7/27/73, McGraw-Hill, pp. 5-17 to 5-23.

Primary Examiner—J. V. Truhe
Assistant Examiner—Eugene S. Indyk
Attorney, Agent, or Firm—Mason, Kolehmainen, Rathburn & Wyss

Related U.S. Patent Documents

Reissue of:

[64] Patent No.: **4,025,838**
 Issued: **May 24, 1977**
 Appl. No.: **536,542**
 Filed: **Dec. 26, 1974**

[51] Int. Cl.³ **G05B 19/00**

[52] U.S. Cl. **318/568; 318/569; 318/574; 318/632; 318/562**

[58] Field of Search **318/561, 567, 568, 569, 318/572, 574, 632, 570, 571, 573, 562**

[56] **References Cited**

U.S. PATENT DOCUMENTS

3,551,656	12/1970	Wohlfeil	318/572
3,555,252	1/1971	Garden	318/561
3,757,187	9/1973	Arai	318/568
3,770,947	11/1973	Deily	318/572
3,825,731	7/1974	Kobayashi et al.	318/569
3,889,238	6/1975	Sakurai	318/569

[57] **ABSTRACT**

The invention discloses a digital position instruction signal modification device for use with a memory controlled manipulator apparatus of the type in which, during a teaching operation, a desired position of manipulator arm means is stored in memory means, and the stored position is read out during repetitive work cycles to cause the manipulator apparatus to reproduce a series of motions taught during the teaching operation. The digital position instruction or command read out from the memory means may be modified by a modifying value entered by a modifying value setting device so that all or desired digital position command or instruction signals stored in the memory means may be modified without repeating the teaching operation.

27 Claims, 7 Drawing Figures

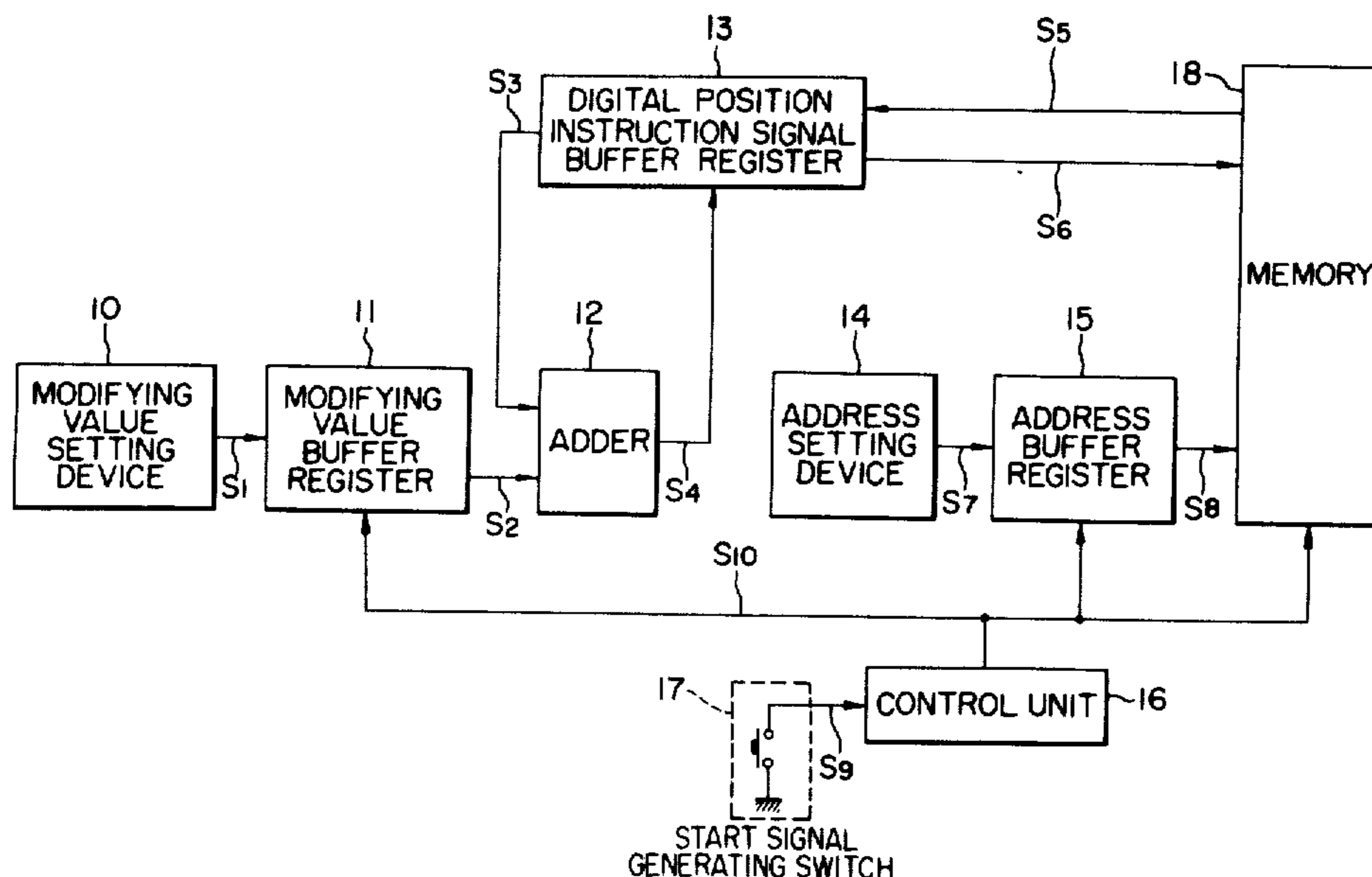

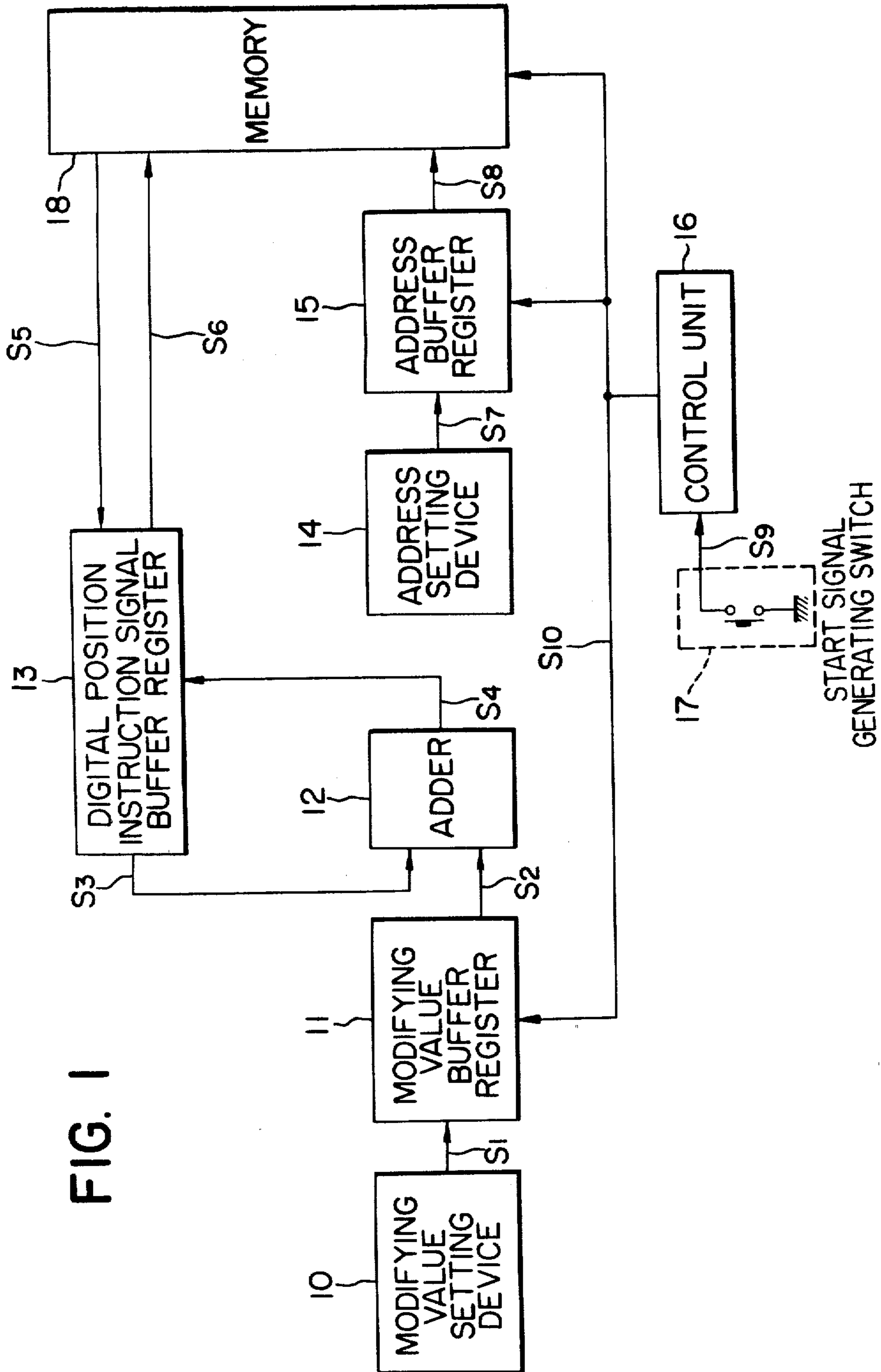

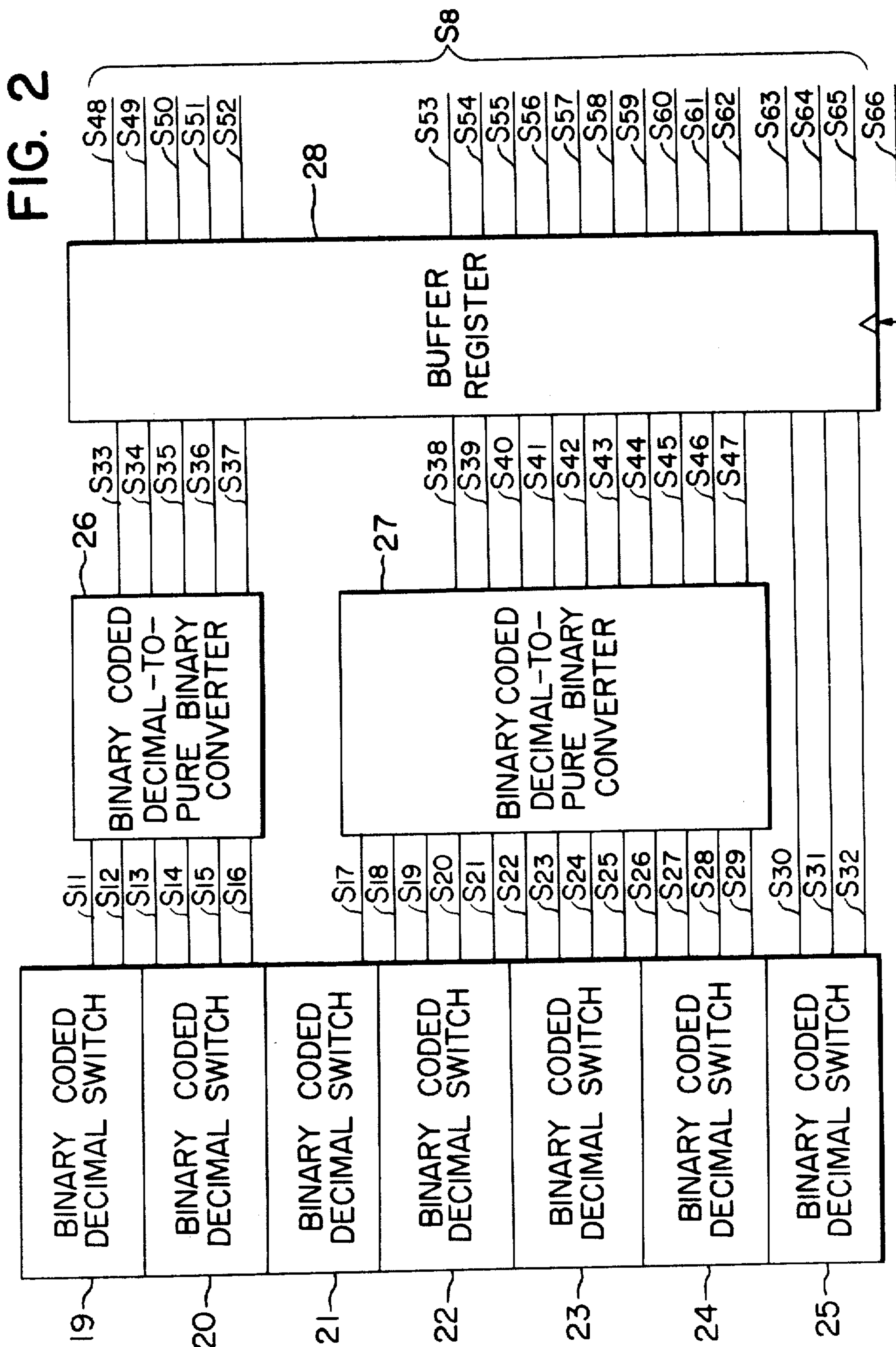

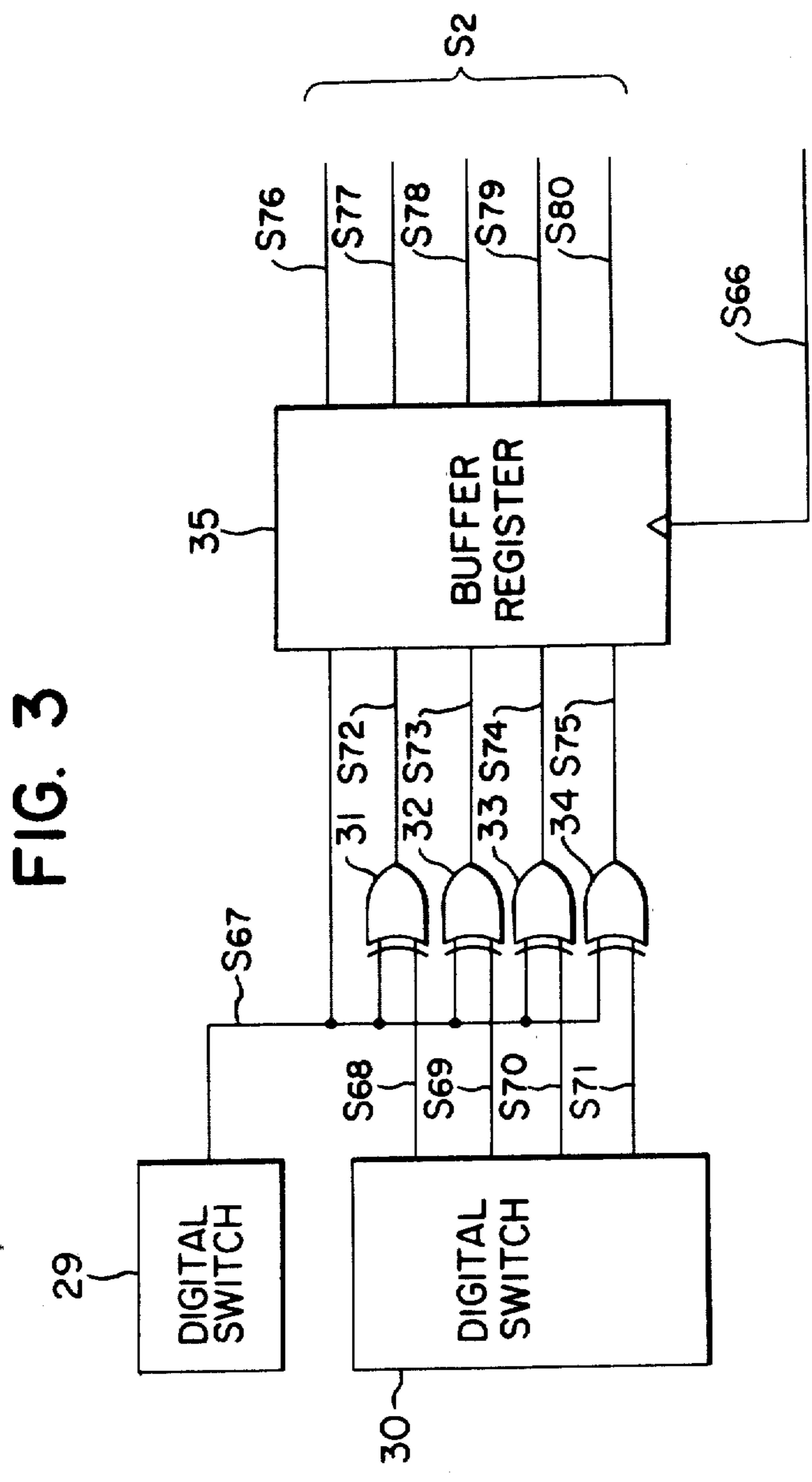

FIG. 3

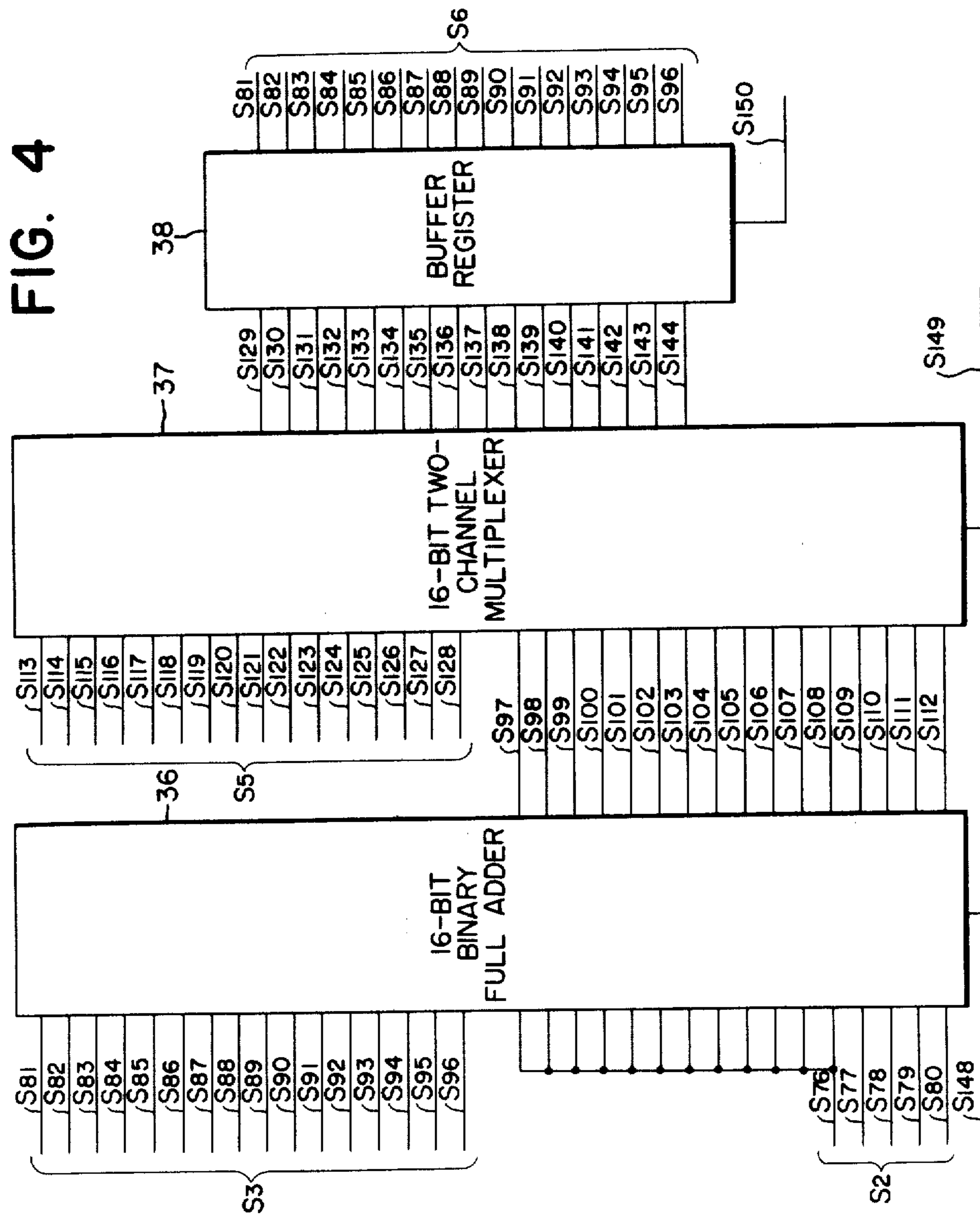

FIG. 5B

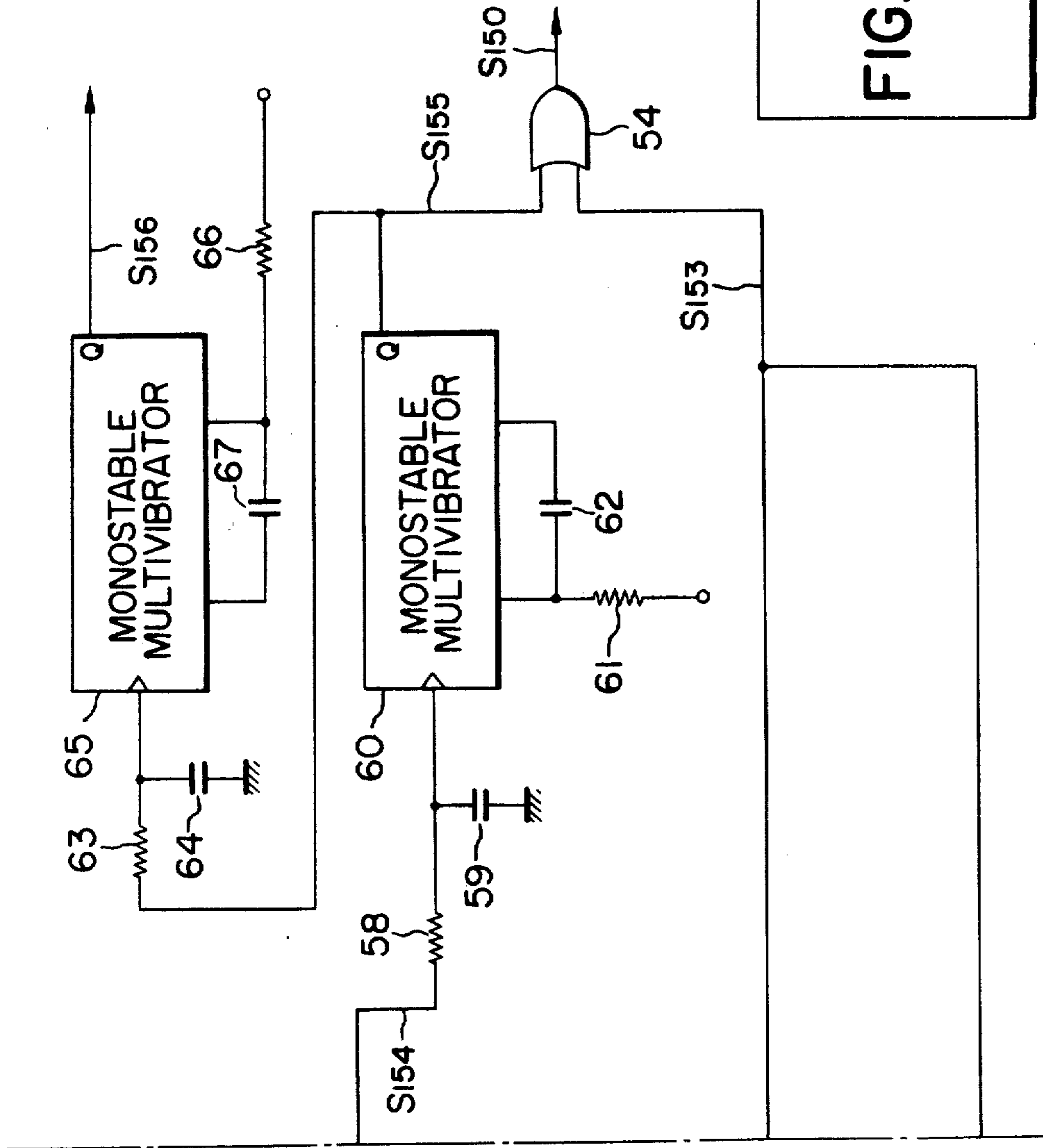

FIG. 5

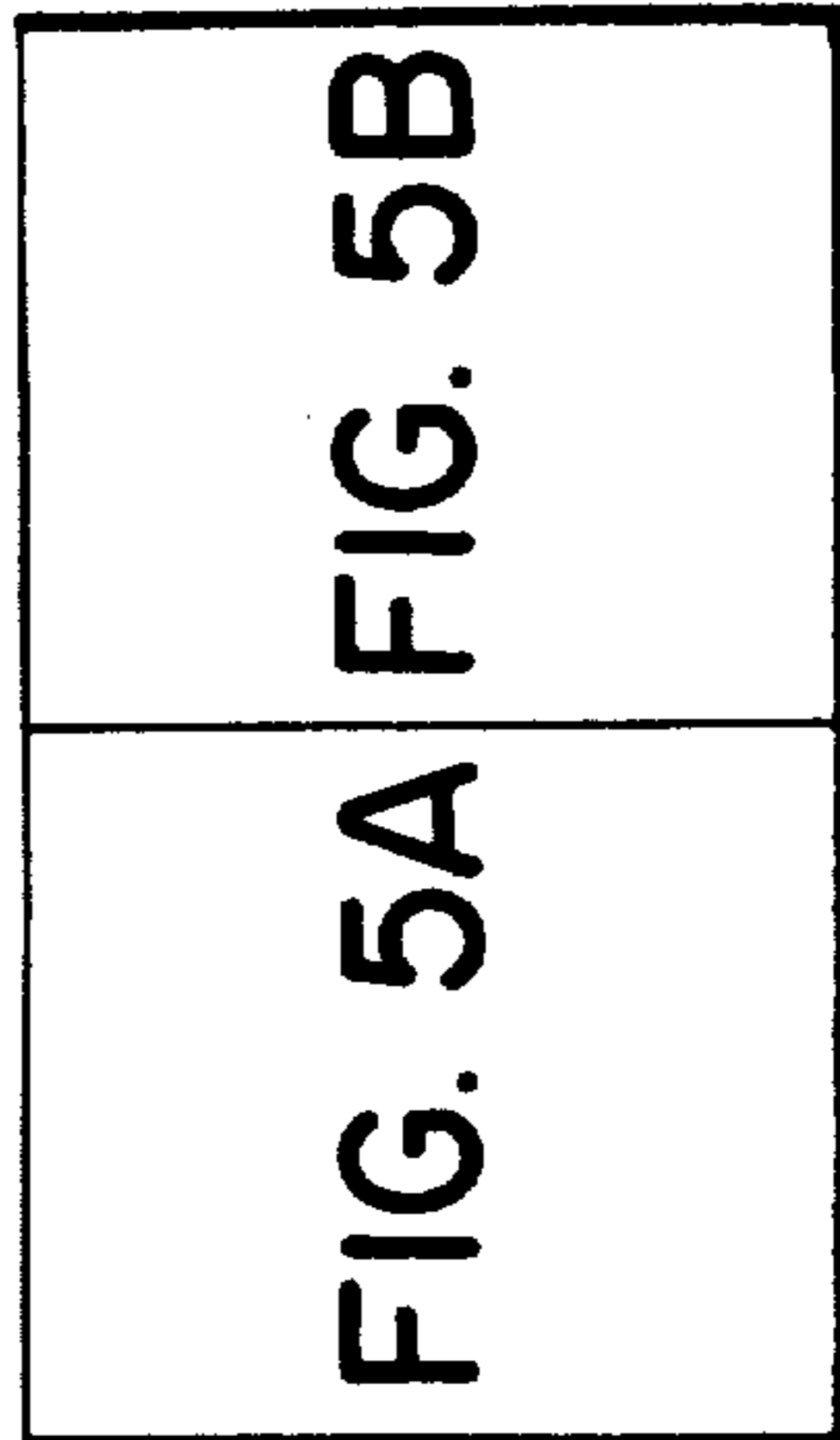
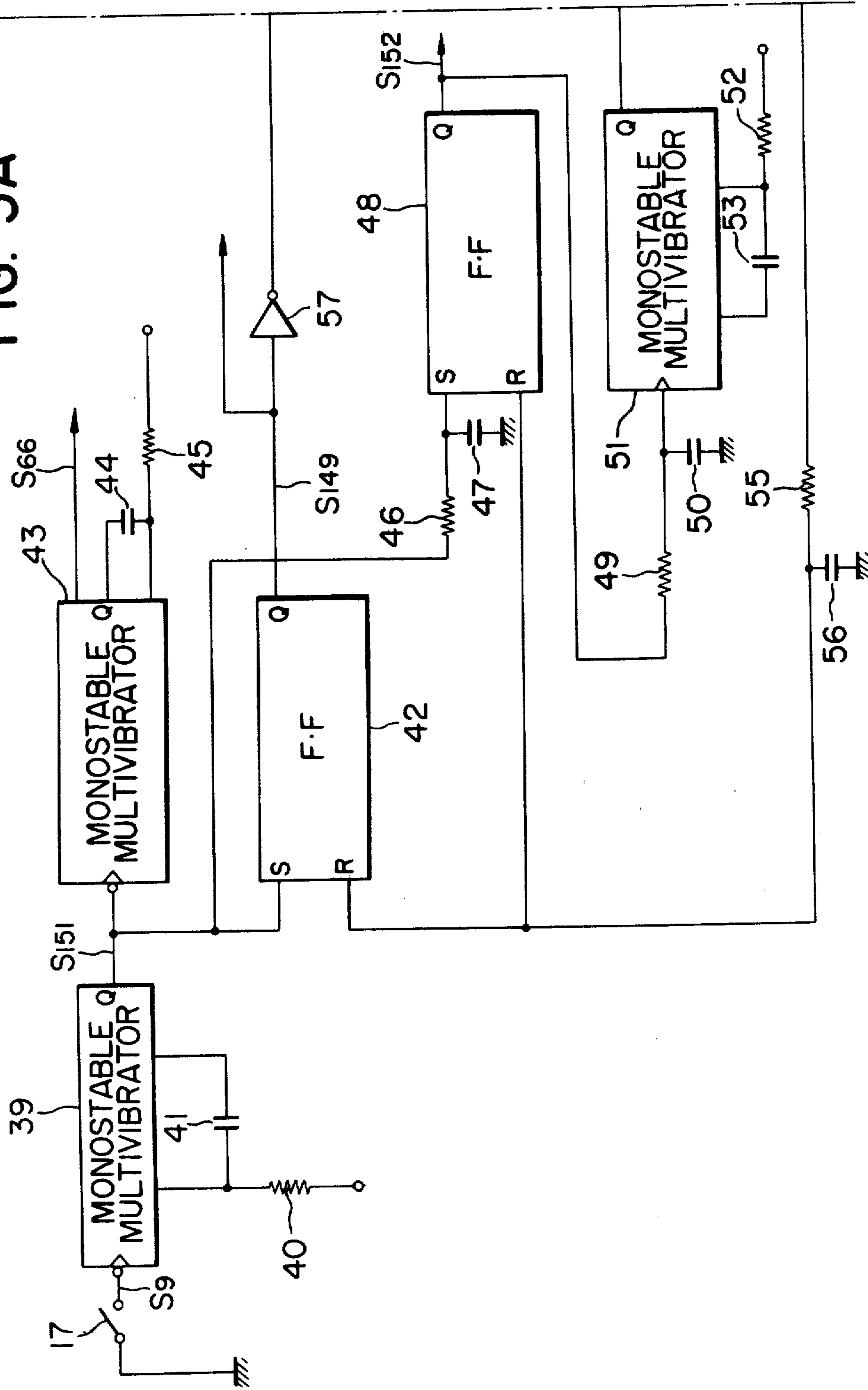
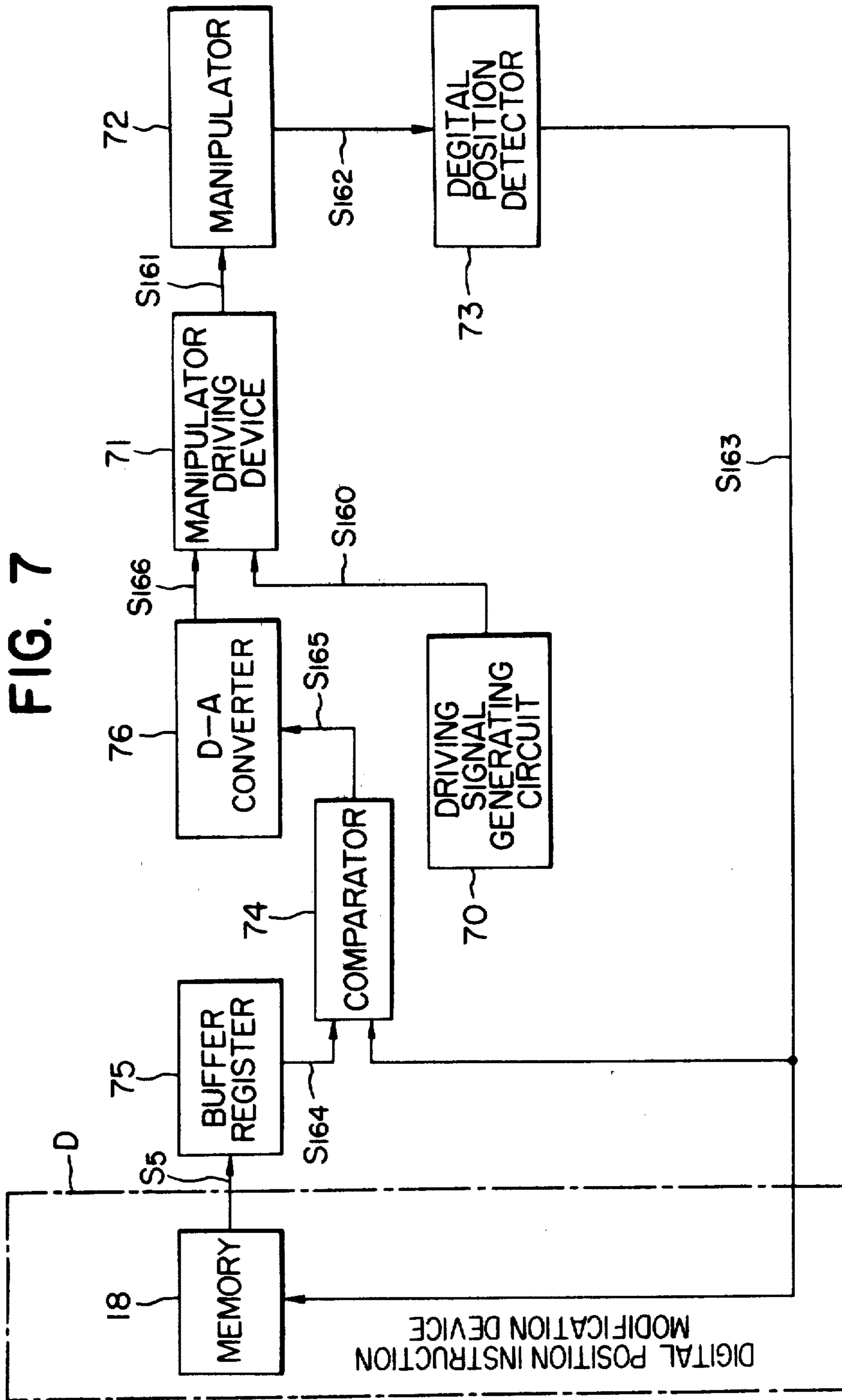

FIG. 5A





SIGNAL MODIFICATION DEVICE FOR MEMORY CONTROLLED MANIPULATOR APPARATUS

Matter enclosed in heavy brackets [] appears in the original patent but forms no part of this reissue specification; matter printed in italics indicates the additions made by reissue.

BACKGROUND OF THE INVENTION

The present invention relates to generally a memory controlled manipulator apparatus capable of repetitively performing reproducible operations, and more particularly to a digital position instruction or command signal modification device for use with a memory controlled manipulator apparatus, which may modify some or all of the digital position instruction or command signals stored in a memory without repeating the manual teaching operation, merely by setting or entering desired modifying values.

In order to enable a manipulator device to perform a desired series of programmed operations in succession during the repetitive working cycles, the manipulator is manually and sequentially displaced during the teaching operation from one desired position to another according to the desired series of operations to be performed, so that digital position signals representing the desired positions of the manipulator may be stored in a memory. Instruction signals for peripheral equipment for enabling various operations to be performed in cooperation or synchronism with the manipulator are simultaneously in the memory with operation instruction signals such as the driving speed instruction signals for the manipulator. In repetitive working cycles, the digital position signals and other various instruction signals stored in the memory are sequentially read out so that the manipulator may perform the desired series of operations. In the operation of manipulator apparatus of the above type, it is necessary to modify some or all of the digital position instruction signals stored in the memory when the actual position of the manipulator deviates from a programmed position or when the position of the manipulator with respect to an article to be handled by the manipulator is changed. For this purpose, the new teaching operation must be performed in the conventional manipulator apparatus, resulting in the considerable loss in time.

SUMMARY OF THE INVENTION

In view of the above, one of the objects of the present invention is to provide an improved programmed manipulator apparatus which overcomes the above and other defects and problems encountered in the conventional manipulator apparatus.

Another object of the invention is to provide an improved programmed manipulator apparatus in which the digital position instruction signals may be modified by a simple operation without repeating or performing a new teaching operation.

Briefly stated, the present invention may be practiced using a memory-repeated reproducible operating manipulator apparatus of the type in which the digital signals produced when the manipulator is sequentially displaced from one desired position to another during the manual teaching operation to perform a desired series of operations are stored in a memory as the digital position instruction signals which are used to cause the manipulator to perform or reproduce the desired series

of operations in succession in the repetitive working cycles. According to the present invention, it is not required to perform a new teaching operation when some or all of the digital position instruction signals stored are to be modified. The modification of the desired digital position instruction signals stored may be effected only by entering or setting a modifying value and the address in the memory of a digital position instruction signal to be modified.

BRIEF DESCRIPTION OF THE DRAWING

FIG. 1 is a block diagram of an instruction modification device used for the explanation of the underlying principle of the present invention;

FIG. 2 is a detailed block diagram of an address setting device and an address buffer storage for the device shown in FIG. 1;

FIG. 3 is a detailed block diagram of a modifier setting device and a modifier buffer storage for the device shown in FIG. 1;

FIG. 4 is a detailed block diagram of an adder and a digital position instruction signal buffer storage for the device shown in FIG. 1;

FIG. 5 is a detailed block diagram of a control unit for the device shown in FIG. 1;

FIG. 6 is a timing chart used for the explanation of the mode of operation of the control unit shown in FIG. 5; and

FIG. 7 is a block diagram of one preferred embodiment of a programmed manipulator apparatus in accordance with the present invention, incorporating the instruction modification device shown in FIG. 1.

DESCRIPTION OF THE PREFERRED EMBODIMENT

Referring first to FIG. 1, therein is shown a digital position instruction modification device D comprising a modifying value setting device 10, a modifying value buffer register 11, and adder 12, a digital position instruction signal buffer register 13, an address setting device 14, an address buffer register 15, a control unit 16, a start signal generating switch 17, and a memory 18 in which are stored digital position instructions generated during the teaching operation of a manipulator apparatus. In response to the start signal S_9 from the switch 17, the control unit 16 is actuated to apply the control signal S_{10} to the buffer register 15 so that the address signal S_7 set by the address setting device 14 is transferred into the address buffer register 15. The digital position instruction S_5 stored at the address designated by the address signal S_8 from the address buffer register 15 is thereby read out from the memory 18 and transferred to the digital position instruction buffer register 13. Also in response to the control signal S_{10} from the control unit 16, the modifying value signal S_1 set by the modifying value setting device 10 is transferred to the modifying value buffer register 11. The modifying value signal S_2 from the buffer register 11 and the digital position instruction signal S_3 from the buffer register 13 are added in the adder 12, and the output (modified position signal) S_4 from the adder 12 is stored in the digital position instruction buffer register 13. The modified digital positioning (position) instruction signal S_6 from the buffer register 13 is stored at the address in the memory 18 designated by the address signal S_8 from the address signal buffer register 15. (As will be apparent in the following description, the con-

trol signal S_{10} is actually comprised of a series of separate control signals.)

Thus the digital position instructions may be easily modified within a short time without performing a new teaching operation in the manipulator apparatus by setting by the address setting device 14 an address of a digital position instruction to be modified, setting by the modifying value setting device 10 a modifying value, and repeating the above two steps.

Next referring to FIGS. 2-6, the construction of the structural components of the digital position instruction modification device D will now be described in detail.

Referring to FIG. 2 illustrating in block diagram form the address setting device 14 and the address signal buffer register 15, a two-digit decimal number selected from the range between 00 and 31 is entered by two binary coded decimal switches 19 and 20, and the binary coded decimal signals S_{11} through S_{16} representing the entered decimal number are applied to a binary coded decimal-to-pure binary converter 26 to be converted into the pure binary signals S_{33} through S_{37} . In like manner, the binary coded decimal signals S_{17} through S_{29} representing a four-digit decimal number selected from the range between 0000 and 1023 entered by four digital switches 21 through 24 are applied to a binary coded decimal-to-pure binary converter 27 to be converted into the pure binary signals S_{38} through S_{47} . The pure binary signals S_{30} through S_{32} representing a decimal number selected from the range between 0 and 7 and entered by a digital switch 25, and the pure binary signals S_{33} through S_{37} and S_{38} through S_{47} are transferred in response to the change of the control signal S_{66} from 0 to 1 to a buffer register 28 consisting of 18 direct-coupled flip-flops. The pure binary output signals S_{48} through S_{65} from the buffer register 28 make up the address signal S_8 shown in FIG. 1.

Next referring to FIG. 3, the modifying value setting device 10 and its buffer register 11 will be described. The pure binary signals S_{68} through S_{71} representing a decimal number 0, 1, 2, 3, 4, 5, 6, 7, 8, or 9 entered by a digital switch 30 are applied to EXCLUSIVE OR gates 31 through 34, respectively. The polarity signal S_{67} entered by a digital switch 29 is 0 or 1 depending upon whether the decimal number entered by the digital switch 30 is positive or negative, respectively, and is applied also to the EXCLUSIVE OR gates 31 through 34. In response to the change of the control signal S_{66} from 0 to 1, the polarity signal S_{67} and the output signals S_{72} through S_{75} from the EXCLUSIVE OR gates 31 through 34 are transferred into a buffer register 35 consisting of five direct-coupled flip-flops. The pure binary signals S_{76} through S_{80} representing the decimal number with its sign + or - make up the modifying value signal S_2 shown in FIG. 1.

It should be noted that, when the output S_2 represents a negative number, due to the presence of a 1 signal S_{67} from the digital switch 29, the outputs S_{72} - S_{75} of the EXCLUSIVE OR gates 31-34 will be the 1's complement of the pure binary signals S_{68} - S_{71} applied from the digital switch 30 to the EXCLUSIVE OR gates 31-34.

FIG. 4 shows the adder 12 and the digital position instruction buffer register 13. The digital position instruction signals S_{113} through S_{128} forming the signal S_5 read out from the address designated by the address signal S_8 in the memory 18 are transferred into a 16-bit two-channel multiplexer 37. When the control signal S_{149} applied from the control unit 16 to the multiplexer 37 is 1, the channel in which the digital position instruc-

tion signals S_{113} through S_{128} are stored is selected, so that the output signals S_{129} through S_{144} are transferred into a buffer register 38 consisting of 16 direct-coupled flip-flops, in response to the change from 0 to 1 of the control signal S_{150} applied to the buffer register 38 from the control unit 16. The output signals S_{81} through S_{96} from the buffer register 38 are applied to a 16-bit binary full adder 36 so as to be added to the pure binary signals S_{76} through S_{80} from the buffer register 35 (See FIG. 3).

When a positive modification is to be made, i.e., when the modifying value is positive, as discussed above, the signal S_{76} , corresponding to the polarity, is 0, and the signals S_{77} - S_{80} are a pure binary signal corresponding to the decimal digit to be added. When the number is to be subtracted, i.e., when the modifying value is negative, as discussed above, the signal S_{76} is 1, and the signals S_{77} - S_{80} correspond to the 1's complement of the pure binary signal representing the decimal digit. Thus, in accordance with known arithmetic techniques, when the modifying value is negative, the 1's complement signal S_{77} - S_{80} is added to the quantity to be modified in the full adder 36, and the 1 signal S_{76} is added to the least significant digit in the full adder 36 as an end around carry signal, so that the desired subtraction is effected by adding. The principle of this technique of subtraction is well known.

In the system of FIG. 4, the signal S_{76} is applied to the least significant digit of adder 36 as the carry input signal S_{148} .

The output signals S_{97} through S_{112} from the adder 36 are transferred into the other channel of the multiplexer 37, are thence applied to the buffer register 38 when the control signal S_{149} is 0, and are stored in the buffer register 38 in response to the change from 0 to 1 of the control signal S_{150} applied to the buffer register 38 as the modified digital position instruction signals.

Next referring to FIGS. 5 and 6, the control unit 16 will be described. When a switch 17 is closed, the signal S_9 changes from 1 to 0 so that a monostable multivibrator 39 is triggered to generate the shot pulse start signal S_{151} whose pulse duration is dependent upon the time constant which in turn is dependent upon the values of a resistor 40 and a capacitor 41. The start signal S_{151} sets an R-S flip-flop 42 so that the control signal S_{149} at the output thereof changes to 1. The control signal S_{149} is applied to the multiplexer 37 (See FIG. 4) and to the memory 18 (See FIG. 1) so that the latter is driven into the read mode. When the start signal S_{151} changes from 1 to 0, a monostable multivibrator 43 is triggered to generate the control signal S_{66} (see FIGS. 2 and 3) whose pulse duration is dependent upon a time constant of a circuit consisting of a resistor 44 and a capacitor 45. The start signal S_{151} is also applied to an R-S flip-flop 48 by way of a series resistor 46 and shunt capacitor 47, so that the triggering of the R-S flip-flop by the signal S_{151} is delayed by a time corresponding to the time constant which is determined by the values of resistor 46 and capacitor 47. Upon being triggered, the R-S flip-flop 48 generates the read signal S_{152} to be applied to the memory 18.

The read signal S_{152} is applied to monostable multivibrator 51 by way of series resistor 49 and shunt capacitor 50, so that the triggering of the monostable multivibrator 51 by the signal S_{152} is delayed by a time corresponding to the time constant determined by the values of resistor 49 and capacitor 50. Upon being triggered, the monostable multivibrator 51 generates a shot pulse signal S_{153} whose pulse duration is dependent upon the

time constant of a circuit consisting of a resistor 52 and a capacitor 53. The shot pulse signal S_{153} is applied as one input of an OR gate 54, whose output S_{150} is applied as the control signal to the buffer register 38 (See FIG. 4).

The shot pulse signal S_{153} which is applied by way of a time constant circuit consisting of a series resistor 55 and a shunt capacitor 56 to the reset terminals of the R-S flip-flops 42 and 48 so that their output signals S_{149} and S_{152} are changed from 1 to 0 after a delay time corresponding to the time constant of resistor 55 and capacitor 56.

The signal S_{149} passes through an inverter 57 to become the inverted signal S_{154} . The signal S_{154} is applied by way of a time constant circuit consisting of a series resistor 58 and a shunt capacitor 59 to a monostable multivibrator 60 so that following a delay determined by the resistor 58 and capacitor 59, the multivibrator 60 generates a shot pulse output signal S_{155} whose pulse duration is dependent upon the time constant of a circuit consisting of a resistor 61 and a capacitor 62. The output pulse signal S_{155} is applied as a second input to the OR gate 54, the output of which is applied as the control signal S_{150} to the buffer register 38 as above discussed.

The output pulse signal S_{155} is applied by way of the time constant circuit consisting of a series resistor 63 and a shunt capacitor 64 to a monostable multivibrator 65 to trigger the multivibrator 65 after a delay corresponding to the time constant of resistor 63 and capacitor 64. The multivibrator 65 in turn generates the write pulse signal S_{156} having pulse duration dependent upon the time constant of a circuit consisting of a resistor 66 and a capacitor 67. The signal S_{156} is applied to the memory 18.

In the sequence of operation of the system of FIG. 1, under the control of the signals illustrated in FIG. 6, generated by the control circuit of FIG. 5, in the first step the control signal S_{149} is applied to the memory 18, to set the memory in the read mode. This signal also sets the multiplexer 37 so that its output corresponds to the first channel, i.e., the signals S_{113} - S_{128} . Then the control signal S_{66} effects the storage in the address buffer register 15 of the address set in the setting device 14, so that the address of the data to be modified is applied to the memory 18. The signal S_{66} also effects the storage in the buffer register 11 of the modifying value set in the setting device 10, so that the modifying signal is applied to the adder 12. Then, the read signal S_{152} reads out the address data of the memory 18 for application to the first channel of the multiplexer 37, and since at this time the multiplexer 37 under control of the signal 149 is still switched to the first channel, the following first pulse of the control signal S_{150} effects the storage in the buffer register 38 of the data previously stored in the memory 18. This data is applied to the adder 36.

The signals S_{149} and S_{152} are then released, to remove the memory from the read mode, and to switch the multiplexer 37 to the second channel. Then, the second pulse of the control signal 150 effects the storage in the buffer register 38 of the data applied to the second channel of multiplexer 37, i.e., the data modified in the adder 36. Since the output of the buffer register 38 is also applied to the memory 18, the subsequent write pulse signal 156 applied to the memory 18 effects the writing in the memory of the modified data, at the selected address.

FIG. 7 illustrates a manipulator apparatus in accordance with a preferred embodiment of the invention, incorporating means for modifying the digital position instructions. In this figure, the block D represents the digital position instruction modifying device illustrated in FIG. 1, incorporating the memory 18.

Referring to FIG. 7, a driving signal generating circuit 70 is provided for producing a control signal S_{160} , for driving a manipulator 72 during a manual teaching operation. The driving signal S_{160} is an analog signal, and is applied to a manipulator driving device 71, which produces an output signal 161 in response to input signals applied thereto, for driving the manipulator 72. The manipulator 72 may, for example, be a mechanical arm adapted to position objects in a desired manner. A digital position detector 73 is mechanically coupled to the manipulator 72, for example by means of the coupling S_{162} , whereby the detector 73 provides an output digital signal S_{163} corresponding to the position of the manipulator 72. This signal is applied to the memory 18 in the digital position instruction modification device D, and is stored therein as a digital position instruction signal. Thus, in a manual teaching operation, the manipulator 72 may be controlled to perform a desired sequence of movements, in response to the control thereof by the signal S_{160} from the signal generating circuit 70. The signal generating circuit 70 may be manually controlled. The addressing of the memory with respect to given instruction signals may be effected in any conventional manner, so that the programmed steps for the movements of the manipulator are readily accessible in the memory 18.

In the motion reproduction mode or repetitive working cycles of the manipulator, the digital position signals S_{163} are no longer applied to the memory 18, being applied instead to the comparator 74. In this position, the digital position instruction signal S_{163} corresponding to the movement of the manipulator 72 to be made is read out of the memory 18, and stored in a buffer register 75. The output signal S_{164} from the buffer register 75 is compared in the comparator 74 with the digital position signal S_{163} . The output, or differential signal S_{165} from the comparator 74 is applied to a digital to analog converter 76, for conversion to an analog differential signal S_{166} . The signal S_{166} is applied to the manipulator driving device 71 which, in the motion reproduction mode, is not controlled by the driving signal S_{160} .

In response to the output signal S_{161} from the driving device 71, the manipulator 72 is moved in such a direction as to minimize the differential signal S_{165} . When the differential signal S_{165} becomes zero, the output signal S_{161} disappears, and the manipulator 72 hence stops.

If the positions of the manipulator deviate from programmed positions, or if it is desired to change the position of the manipulator at any given step, in accordance with the present invention, referring to FIG. 1, the address of the instruction corresponding to the position to be changed is set into the address setting device 14, and the modifying value for the given step is set in the modifying value setting device 10. In other words, referring to FIG. 3, digital switch 30 may be manually set to a value corresponding to the desired degree of modification and digital switch 29 may be manually set to provide a 0 or 1 output, dependent upon where the modifying value is to be added or subtracted respectively from the stored signal.

Following the setting of the digital switches 29 and 30 and the address setting device 14, the start signal

switch 17 is depressed, to effect the modification of the program at the determined address, as above described.

While, as above described, a single buffer register 38 may be employed in combination with the 16 bit two channel multiplexer 37, it will be apparent that two separate buffer registers may be employed in place of the single buffer register 38. In such an arrangement, the multiplexer 37 may be omitted, with the first of the substituted buffer registers being connected to directly receive the data from the memory 18, and the second of the buffer registers being connected to directly receive the modified data from adder 36. The output of the first substituted buffer register is connected to the adder 36, but not connected to the memory 18, and the output of the second substituted buffer register is connected to the memory 18. In such an arrangement, the control signals applied to the substituted buffer registers may be suitably modified, for example, by applying the first pulse of the control signal S_{160} to the first buffer register, and by applying the second control pulse of the signal S_{150} to the second buffer register. The control signal S_{150} may be modified for the above purpose by conventional means. While the invention has been disclosed and described with reference to a limited number of embodiments, it will be apparent that variations and modifications may be made therein, and it is intended in the following claims to cover each such variation and modification as falls within the true spirit and scope of the invention.

What is claimed is:

1. A digital position instruction signal modification device for a memory controlled teachable manipulator apparatus of the type comprising

- i. manipulator means for performing a predetermined series of operations in succession at predetermined positions during the operating mode thereof,
- ii. means including a manipulator position detector for generating a digital position signal representing the actual position of said manipulator apparatus,
- iii. memory means for storing therein a plurality of digital position signals generated by said digital position signal generating means during the teaching mode of said manipulator apparatus as the digital position instruction signals to be used for causing said manipulator means to perform said predetermined series of operations, each of said position instruction signals being stored at a corresponding predetermined address within said memory means,
- iv. comparator means for comparing the output signal from said memory means with the output signal from said digital position signal generating means in a motion reproduction mode of said manipulator apparatus to produce an output error signal proportional to the difference between said two output signals, and
- v. manipulator apparatus driving means for driving said manipulator means in such a direction as to make said output error signal zero, thereby causing the position of said manipulator apparatus to correspond with the corresponding instruction signal, characterized in that said digital position instruction signal modification device comprises
 - a. a modifying value setting means coupled to said manipulator position detector for setting a modifying value for modifying a desired digital position signal stored in said memory means,

- b. first buffer register means for storing therein said modifying value from said modifying value setting means,
- c. address setting means for setting the address in said memory means of the digital position instruction signal to be modified,
- d. second buffer register means for storing therein the output from said address setting means,
- e. third buffer register means for storing therein the digital position instruction signal read out from said memory means in response to the output signal from said address setting means,
- f. adder means for adding the modifying value from said first buffer register means to the digital position signal from said third buffer register means, thereby modifying said digital position signal,
- g. fourth buffer register means for storing therein the modified position signal and transferring the same to said memory means, and
- h. manually operable control means operative at times other than during said operating and teaching modes of said manipulator apparatus for controlling the storage of signals in said first, second, third and fourth buffer register means and for controlling the position of said manipulator apparatus at such times.

2. The system of claim 1 wherein said adder comprises a binary full adder, and an output of said first buffer register is connected as an input of said binary full adder.

3. The system of claim 1 further comprising a two channel multiplexer having first and second channels selectively coupled to a common output in response to signals applied to a control terminal, said common output being applied to said fourth buffer register, said means reading out said memory means comprising said first channel and said means for applying the output of said adding means to said fourth register means comprising means applying the output of said adding means to said second channel.

4. The system of claim 3 wherein said control means generates first, second and third and fourth sequentially occurring control signals, further comprising means for applying said first and fourth signals to said memory means as read and write signals respectively, means for applying said second and third signals to said fourth buffer register to effect the storage therein of signals applied thereto, and generated by said control means a fifth signal for connecting said first channel to said fourth buffer register during said second signal, and for connecting said second channel to said fourth buffer register during said third signal.

5. *In a programmable manipulator, the combination of:*
a manipulator arm movable in a plurality of axes;
memory storage means having stored therein a programmed sequence of digital command signals corresponding to the successive program step positions to which said arm is to be moved during each one of a plurality of playback cycles;
address means for causing said stored command signals to appear at the output of said memory means in a predetermined sequence;
means for sequentially moving said arm to the positions represented by said stored command signals; and
means controlled in part by said address means for modifying said stored command signals in at least one preselected program step in accordance with pre-

lected data corresponding to positional modifications in direction and magnitude relative to said one stored program step position and storing said modified command signal in said memory, said modifying means including means for identifying said preselected program step and for controlling said address means to cause said preselected program step command signal to appear at the output of said memory means.

6. The combination of claim 5, wherein said modifying means further includes means for combining the command signal corresponding to said one preselected program step and said preselected positional modification data, and means for transferring said combined modified data into said memory storage means at said one preselected program step location therein.

7. Apparatus for modifying a selected program step or program steps of a programmable manipulator according to preselected positional modification data, the programmable manipulator including a manipulator arm movable in a plurality of axes, memory storage means having stored therein a programmed sequence of digital command signals corresponding to the successive program step positions to which said arm is to be moved during each one of a plurality of playback cycles, address circuitry for causing the stored command signals to appear at the output of said memory means in a predetermined sequence, and means for moving said arm sequentially to the positions represented by said stored command signals, said modifying apparatus comprising:

means for identifying the particular digital command signal to be modified and for controlling said address circuitry;

means for combining said identified digital command signal and said positional modification data to produce a modified positional digital output representing the desired modified position; and

means for controlling the writing of said modified positional output data into said memory storage means at the same address location as said identified command signal.

8. The method of modifying the programming of a manipulator provided with a memory storage means in which are stored a program of digital command signals corresponding to successive different positions to which said manipulator is to be moved during successive program steps, which comprises the steps of, reading a selected one of said command signals out of said memory storage means and temporarily storing the same, combining said temporarily stored command signal with preselected data corresponding to a desired positional modification in direction and magnitude to provide a modified command signal, and storing said modified command signal in said memory storage means.

9. The method of claim 8, wherein said modified command signal is stored at the same address location in said memory storage means as said selected one command signal.

10. The method of claim 8, wherein said combining step is performed by complementary addition with said desired positional modification is in a predetermined direction relative to said one command signal.

11. In a programmable manipulator, the combination of, a manipulator arm movable in a plurality of axes, memory storage means having stored therein a program of digital command signals corresponding to successive different positions to which said arm is to be moved during a playback cycle of said manipulator, means for sequentially moving said arm to the positions represented by said stored

command signals during each one of a plurality of playback cycles, means for establishing a desired increment of movement in a predetermined direction along one of said axes, means jointly controlled by said memory storage means and said increment establishing means for generating a modified command signal and for storing said modified command signal in said memory storage means, said modified command signal differing from an original one of said stored command signals by said desired increment, and means for thereafter utilizing said modified command signal in place of the original command signal to control said arm moving means during succeeding playback cycles.

12. The combination of claim 11, wherein said generating means includes means for writing said modified command signal in said memory storage means.

13. In a programmable manipulator, the combination of, a manipulator arm movable in a plurality of axes, memory storage means having stored therein a program of digital command signals corresponding to successive different positions to which said arm is to be moved during a playback cycle of said manipulator, means for sequentially moving said arm to the positions represented by said stored command signals, modifying value setting means for establishing a desired increment of movement by which one of said command signals is to be modified, address setting means for identifying the address location of said one command signal in said memory storage means, means jointly responsive to said modifying value setting means and said address setting means for developing a modified command signal which differs from said one command signal by said desired increment, and means for storing said modified command signal in said memory storage means at said identified address location.

14. The combination of claim 13, which includes register means, means for reading said one command signal from said memory storage means and temporarily storing the same in said register means, and means jointly responsive to the setting of said modifying value setting means and the output of said register means for adding said desired increment to said one command signal, thereby to develop said modified command signal.

15. The combination of claim 13, wherein said modifying value setting means includes a manually adjustable member which is movable to different positions corresponding to different increments of desired movement to be added to said one command signal.

16. The combination of claim 13, wherein said modifying value setting means includes a first manually adjustable member which is movable to different positions corresponding to different increments of desired movement, and a second manually adjustable member which is movable to either one of two positions corresponding to the polarity of said desired increment of movement relative to said one command signal.

17. The combination of claim 15, which includes means controlled by said manually adjustable member for developing a digital control signal representing said desired increment of movement, and means for supplying said digital control signal to said jointly responsive means.

18. The combination of claim 13, wherein said address setting means includes a manually adjustable member which is movable to different positions corresponding to different address locations in said memory storage means.

19. The combination of claim 18, which includes means controlled by said manually adjustable member for developing a digital control signal representing the address loca-

tion of said one command signal, and means for supplying said digital control signal to said jointly responsive means.

20. The combination of claim 13, wherein said modified command signal is substituted for said one command signal in said memory storage means.

21. The combination of claim 11, which includes a direction establishing member movable to two different positions corresponding to the desired direction of said increment of movement, said generating means being also responsive to the setting of said direction establishing member in generating said modified command signal.

22. The combination of claim 13, wherein said modified command signal developing and storing means includes multiplexer means having first and second input channels, buffer register means, means controlled by said address setting means for transferring said one command signal from said memory storage means to said first input channel of said multiplexing means, means connecting the output of said multiplexing means to said buffer register means so that said one command signal is stored in said buffer register, adder means having first and second inputs, means connecting the output of said adder means to said second input channel of said multiplexing means, means connecting the output of said buffer register to said first input of said adder means, and means connecting the output of said modifying value setting means to said second input of said added means, thereby to develop said modified command signal at the output of said buffer register means when said multiplexer means is connected to said second input channel thereof.

23. The combination of claim 22, wherein said modified command signal developing and storing means further

includes means for writing the output of said buffer register means into said memory storage means.

24. The combination of claim 22, wherein said modifying value setting means includes means for developing a digital control signal corresponding to the magnitude of said desired increment of movement, and means for supplying said digital control signal to said second input of said adder means.

25. The combination of claim 24, which includes a modifying value register whose output is connected to said second input of said adder means, and means connecting said digital control signal to the input of said register.

26. The combination of claim 24, which includes a series of exclusive OR gates connecting said digital control signal to the input of said modifying value register, and means for controlling said OR gates in accordance with the sign of said desired increment of movement.

27. In a programmable manipulator, the combination of, a manipulator arm movable in a plurality of axes, memory storage means having stored therein a program comprising a plurality of digital command signal steps corresponding to successive different positions to which said arm is to be moved during each one of a plurality of playback cycles; means controlled by said stored command signal program steps for sequentially moving said arm to said different positions, means for setting and inputting preselected data corresponding to a desired modification in direction and magnitude of at least one of said stored program steps, means for identifying and addressing said one program step in said memory storage means, means for combining said one program step and said desired positional modification data to produce a modified program step, and means for writing said modified program step into said memory storage means.

* * * * *

40

45

50

55

60

65