



US00D989706S

(12) **United States Design Patent**
Sugino

(10) **Patent No.:** **US D989,706 S**
(45) **Date of Patent:** **** Jun. 20, 2023**

(54) **VALVE COMPONENT FOR VEHICLE TYRES**

(71) Applicant: **PACIFIC INDUSTRIAL CO., LTD.**,
Ogaki (JP)

(72) Inventor: **Takumi Sugino**, Ogaki (JP)

(73) Assignee: **PACIFIC INDUSTRIAL CO., LTD.**,
Ogaki (JP)

(**) Term: **15 Years**

(21) Appl. No.: **29/829,670**

(22) Filed: **Mar. 7, 2022**

Related U.S. Application Data

(62) Division of application No. 35/510,403, filed on Mar. 19, 2020 (U.S. filing date under 35 U.S.C. 384), and having an international filing date of Mar. 19, 2020.

(30) **Foreign Application Priority Data**

Sep. 27, 2019 (WO) PCT/JP2019/038106

(51) **LOC (14) Cl.** **12-15**

(52) **U.S. Cl.**
USPC **D12/607**
CPC **F16K 15/20** (2013.01)

(58) **Field of Classification Search**
USPC D12/604, 606, 607; D23/233, 235
CPC F16K 15/20; F25B 45/00; B60C 29/002;
B60C 29/06; B60C 29/005; F16L 37/40;
Y10T 137/3786; Y10T 137/7613
See application file for complete search history.

(56) **References Cited**

U.S. PATENT DOCUMENTS

3,207,172 A * 9/1965 Steer F16K 1/34
251/366
3,561,467 A * 2/1971 Lutz F16K 15/20
137/234.5

4,462,449 A * 7/1984 Zabel, Jr. B60C 29/00
152/428
6,050,295 A * 4/2000 Meisinger F16K 15/18
137/543
6,637,726 B1 * 10/2003 Yamamoto F16K 1/46
62/292
6,845,969 B2 * 1/2005 Kayukawa B60C 29/02
137/454.6
7,174,910 B2 * 2/2007 Kayukawa F16K 15/20
137/454.5
7,341,210 B2 * 3/2008 Yamamoto F16K 15/205
277/637
7,469,581 B2 * 12/2008 Katou B60C 23/0494
73/146.8

(Continued)

Primary Examiner — Richard E Chilcot

(74) *Attorney, Agent, or Firm* — Oliff PLC

(57) **CLAIM**

The ornamental design for a valve component for vehicle tyres, as shown and described.

DESCRIPTION

FIG. 1 is a front, right-side, top perspective view of a valve component for vehicle tyres, showing the new design; FIG. 2 is a front elevational view thereof; FIG. 3 is a rear elevational view thereof; FIG. 4 is a left-side elevational view thereof; FIG. 5 is a right-side elevational view thereof; FIG. 6 is a top plan view thereof; FIG. 7 is a bottom plan view thereof; FIG. 8 is a front, right-side, top perspective view showing the valve component in a closed state of use; FIG. 9 is a front elevational view showing the valve component in a closed state of use; and, FIG. 10 is a front elevational view showing the valve component in an open state of use. The broken lines depict environment and form no part of the claimed design.

1 Claim, 7 Drawing Sheets

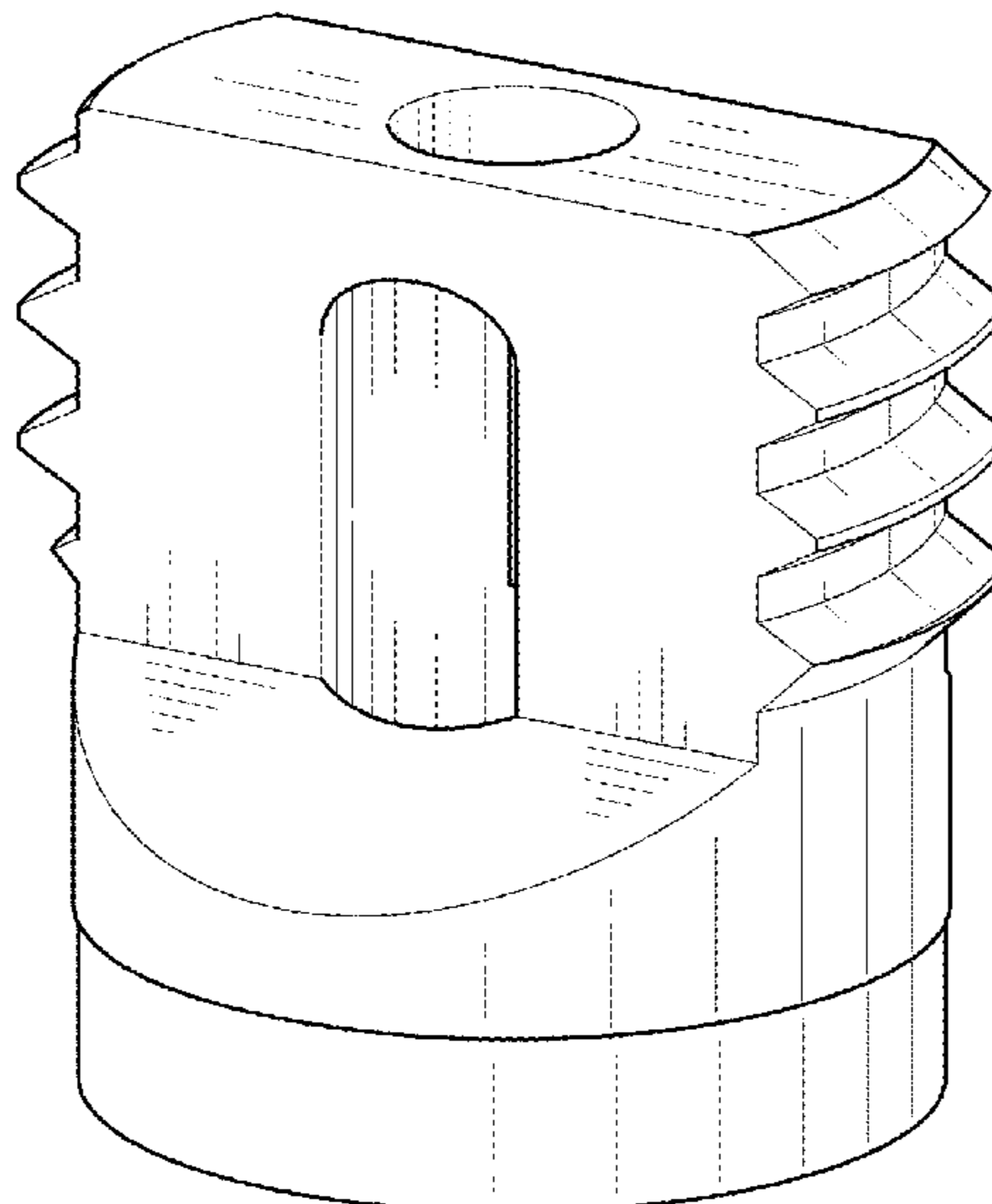

(56)

References Cited

U.S. PATENT DOCUMENTS

10,428,968 B2 * 10/2019 Yamamoto F16K 15/06
11,085,549 B1 * 8/2021 Sugino F16K 15/063
D949,779 S * 4/2022 Sugino F16K 1/36
D12/607
11,313,483 B2 * 4/2022 Sugino F16K 15/20
2018/0274690 A1 * 9/2018 Yamamoto F16K 1/32
2018/0333997 A1 * 11/2018 Vargus B60C 29/002
2018/0370305 A1 * 12/2018 Krefting B60C 29/02
2019/0263201 A1 * 8/2019 Chang B60C 29/005
2019/0390785 A1 * 12/2019 Moore F16K 15/20
2020/0408314 A1 * 12/2020 Sugino F16K 15/20
2021/0387489 A1 * 12/2021 Sugino F16K 1/48

* cited by examiner

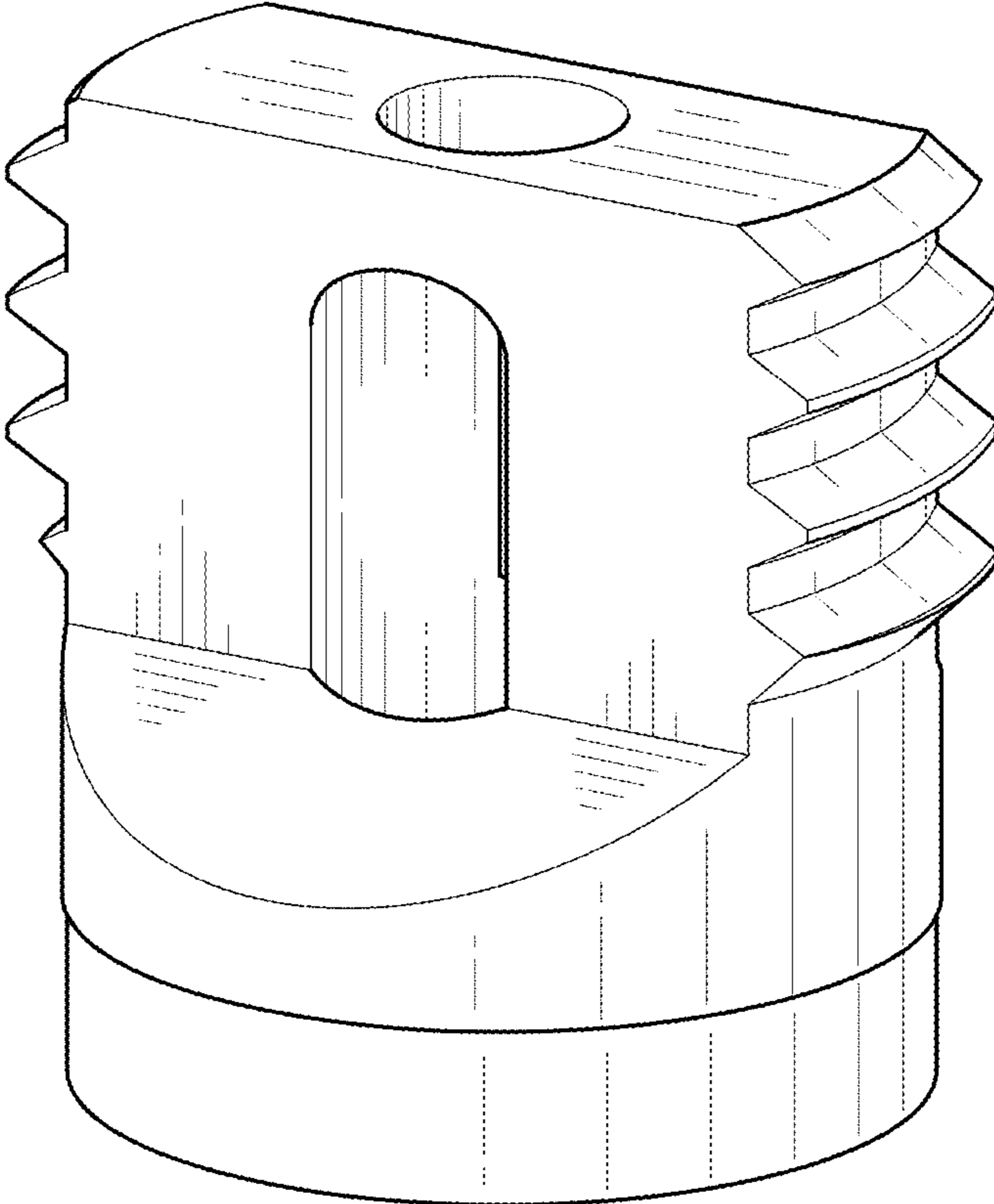

FIG. 1

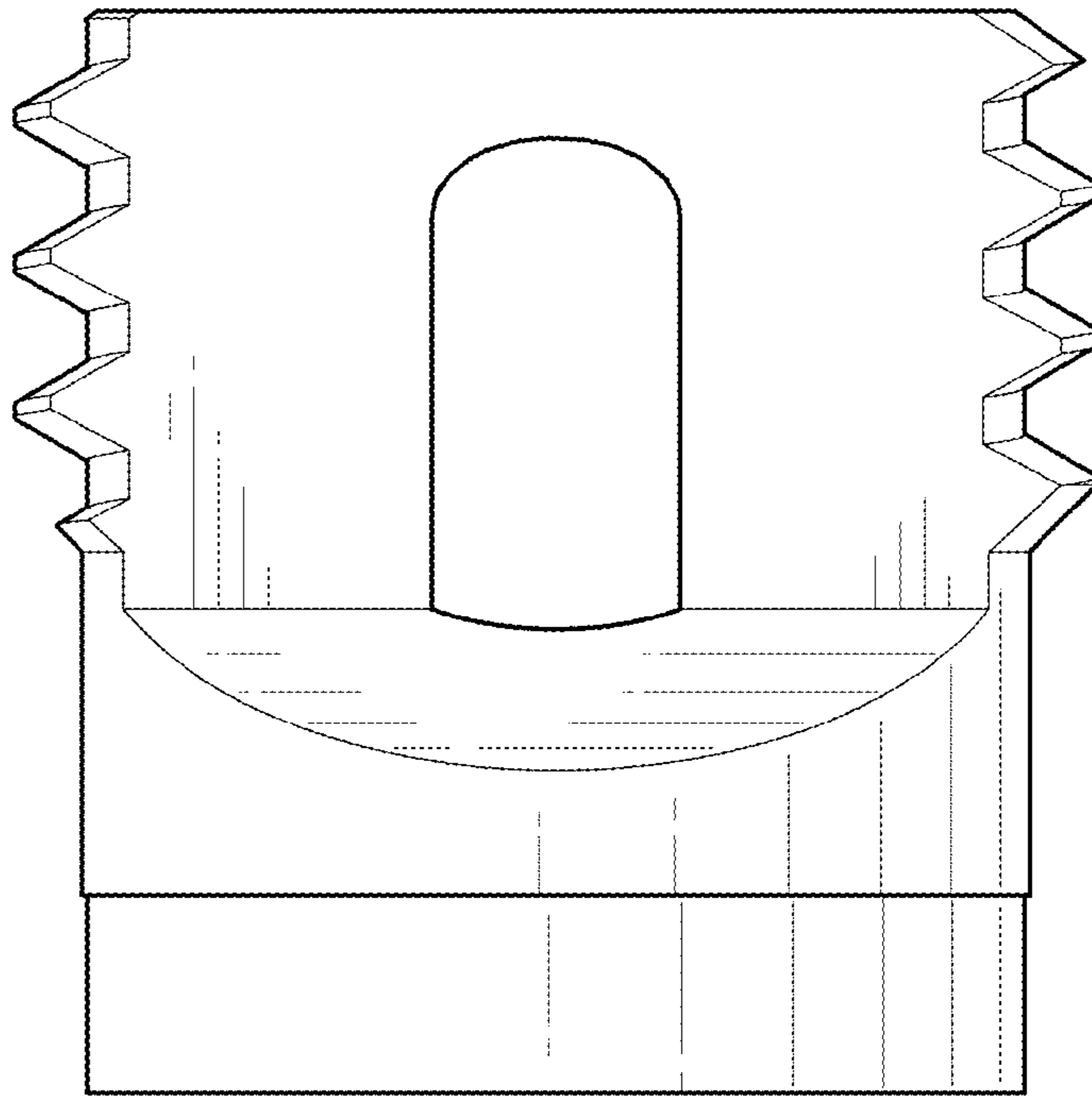

FIG. 2

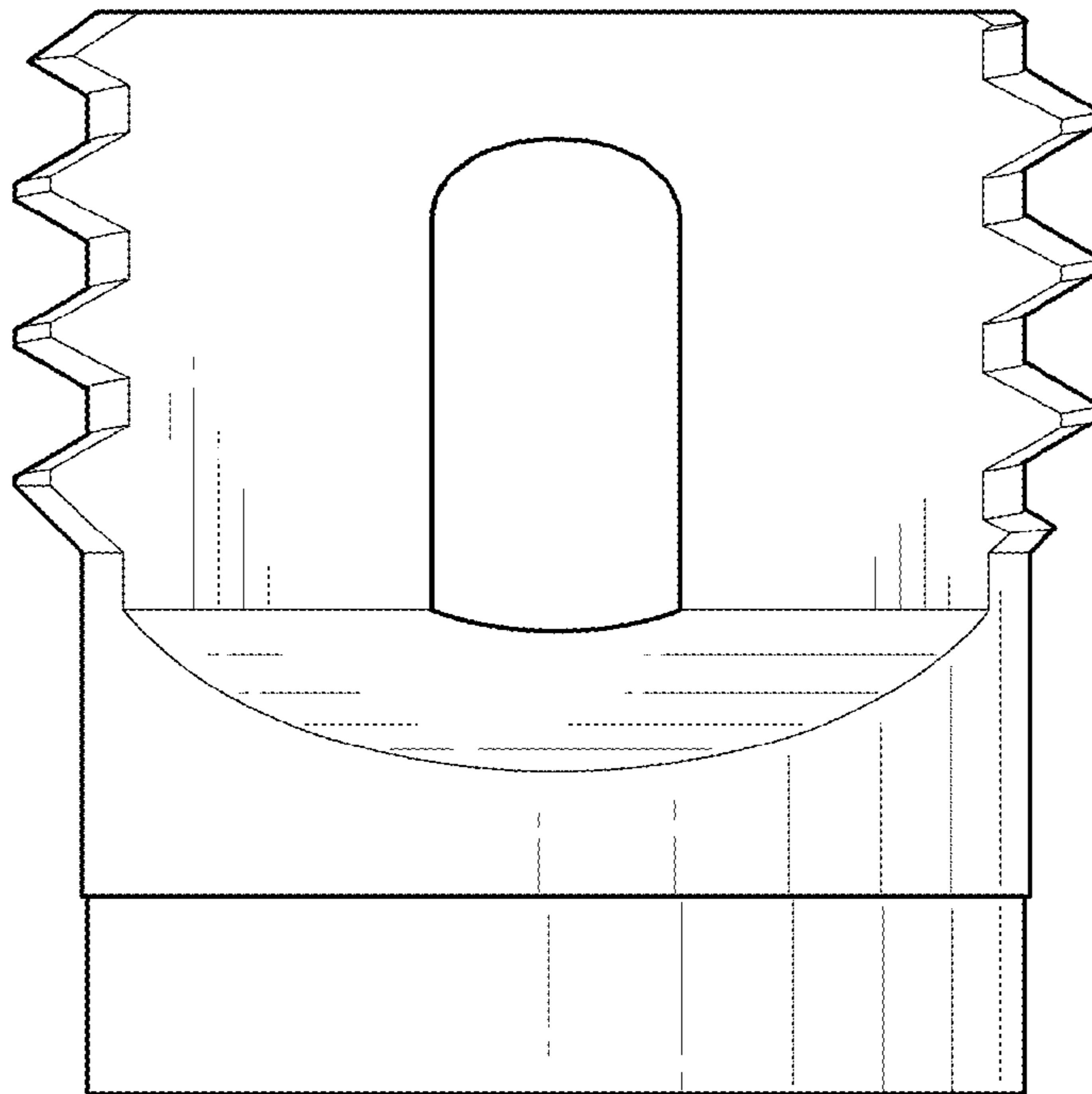

FIG. 3

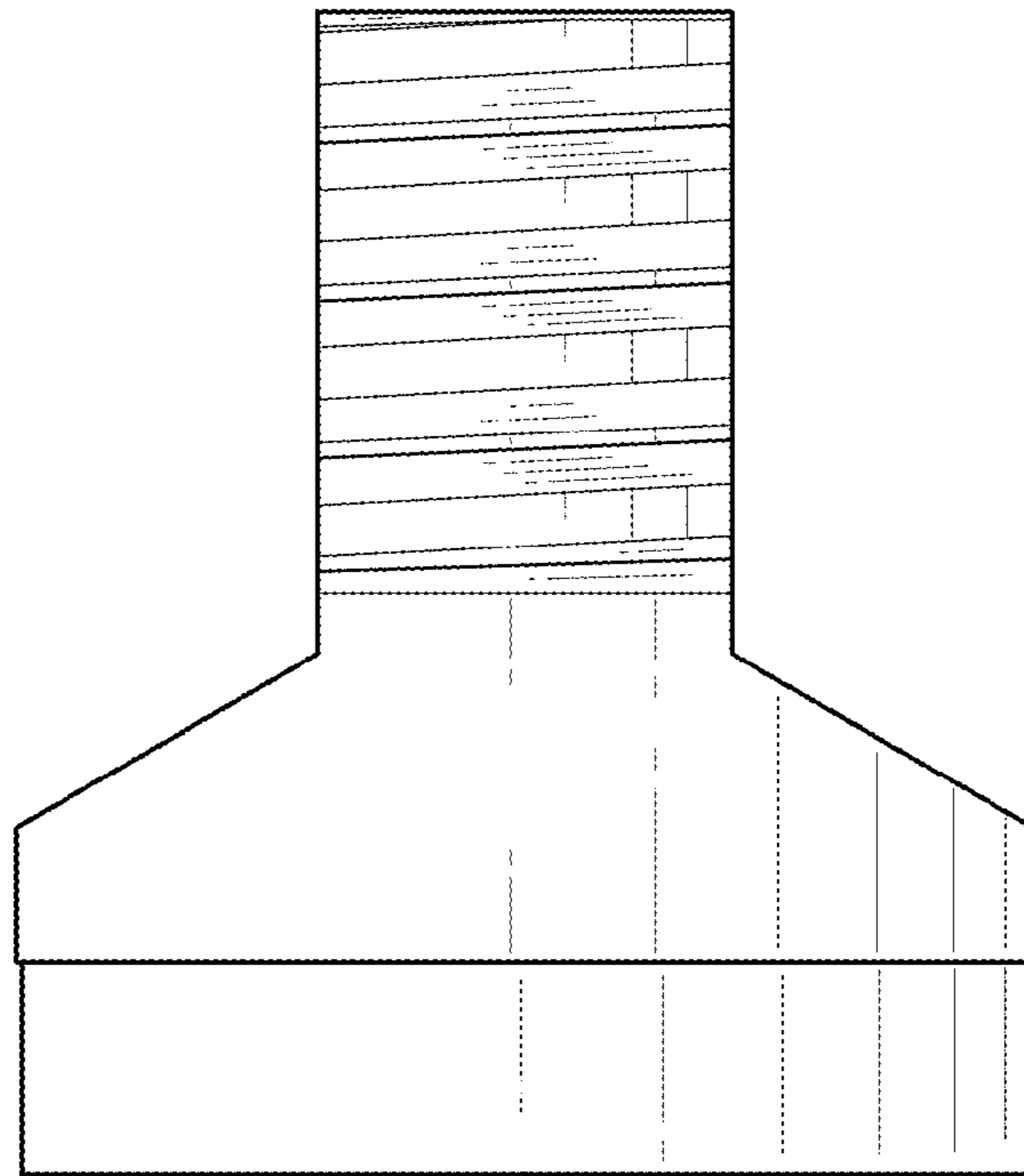

FIG. 4

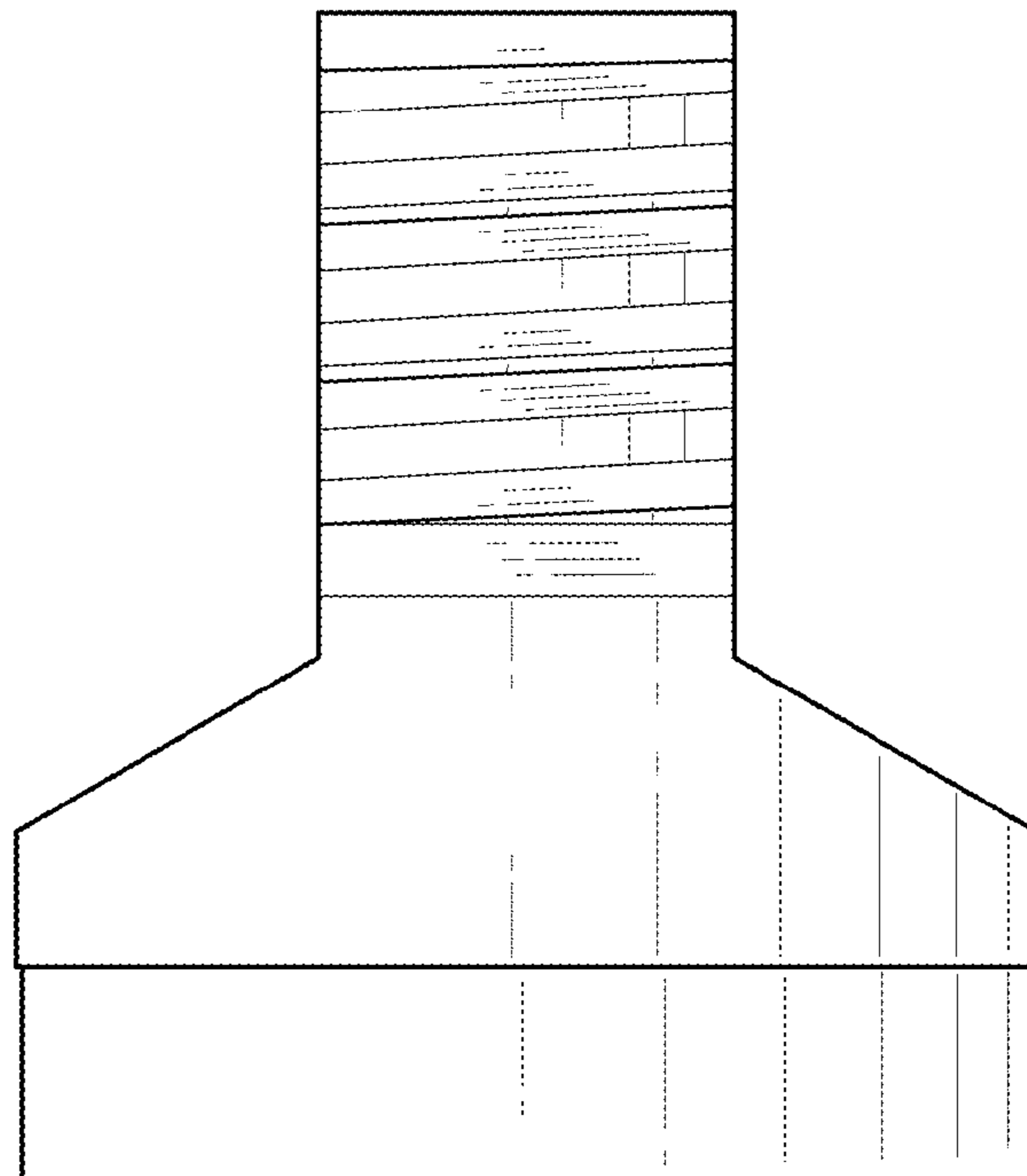

FIG. 5

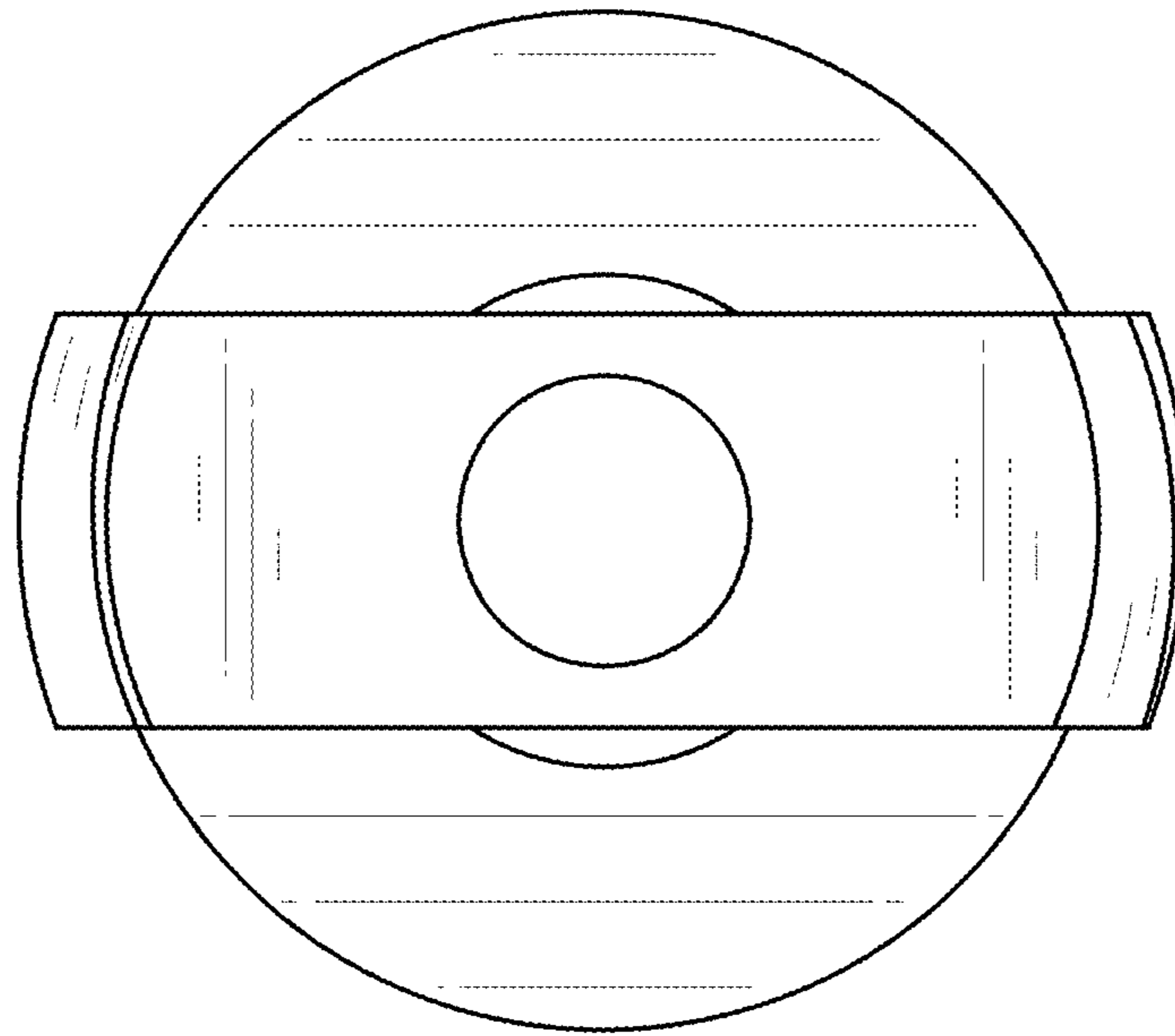

FIG. 6

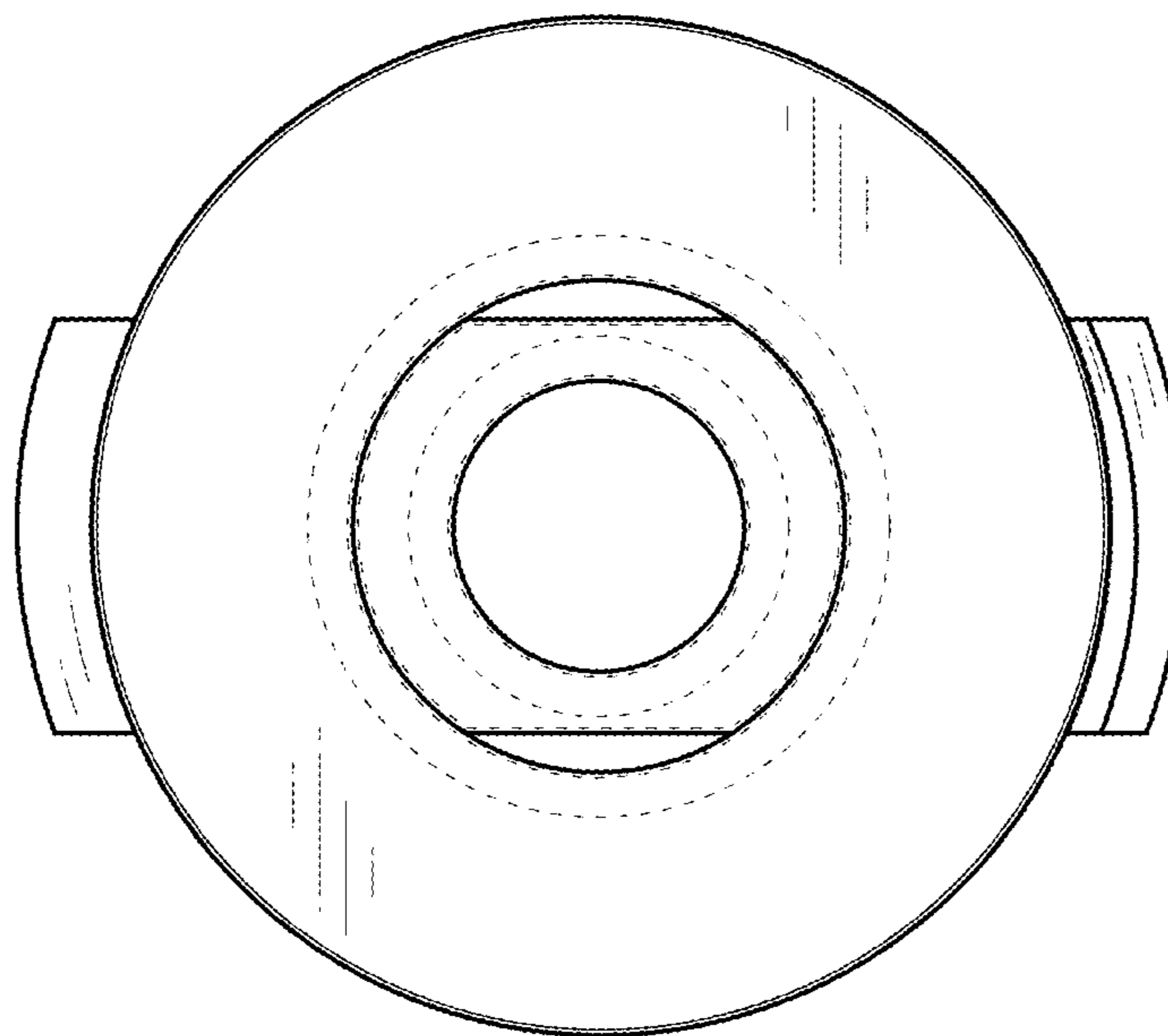

FIG. 7

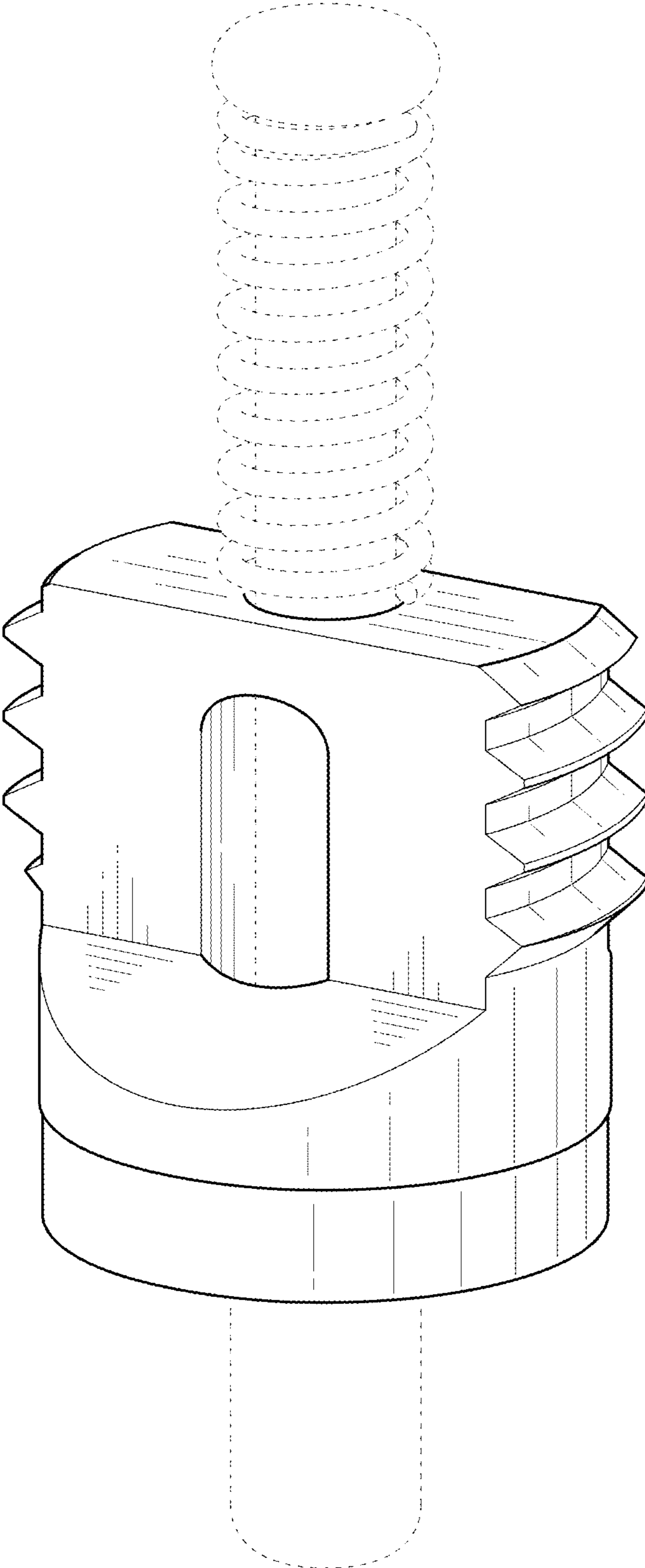

FIG. 8

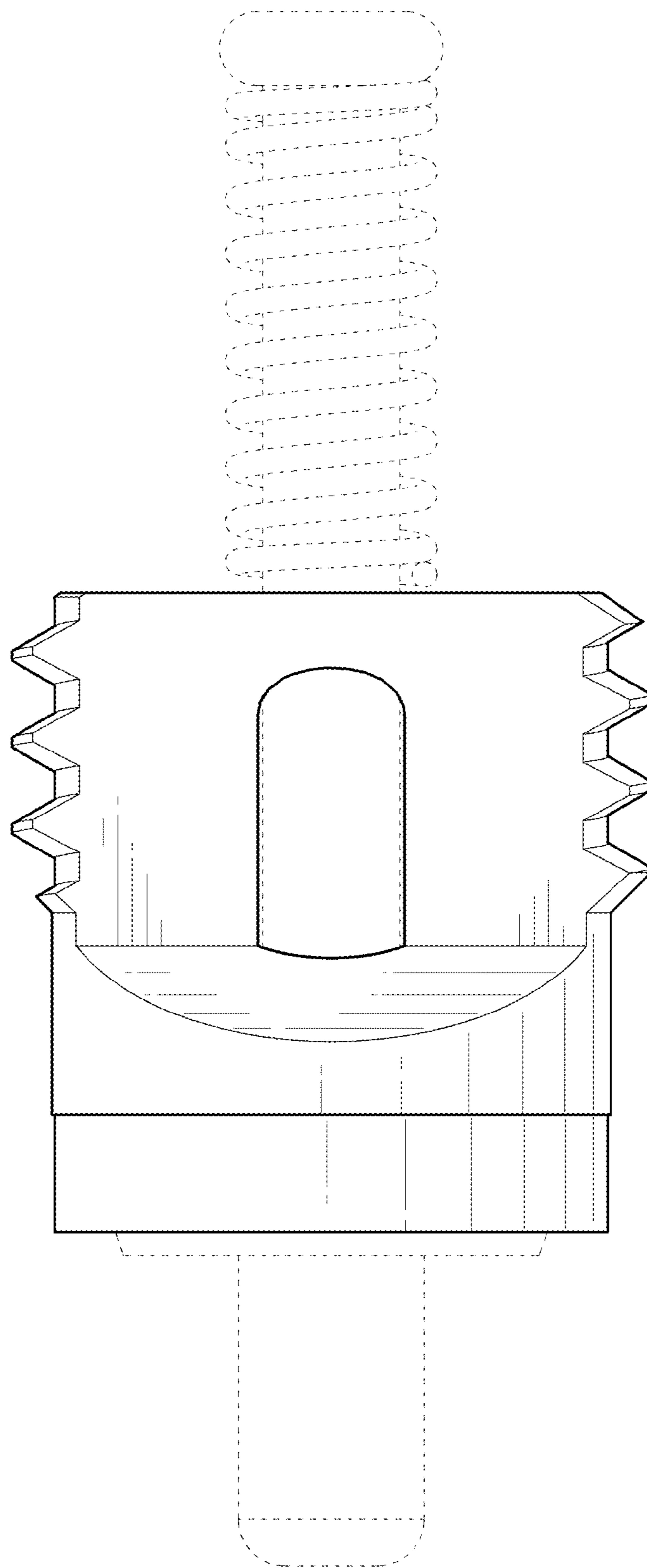

FIG. 9

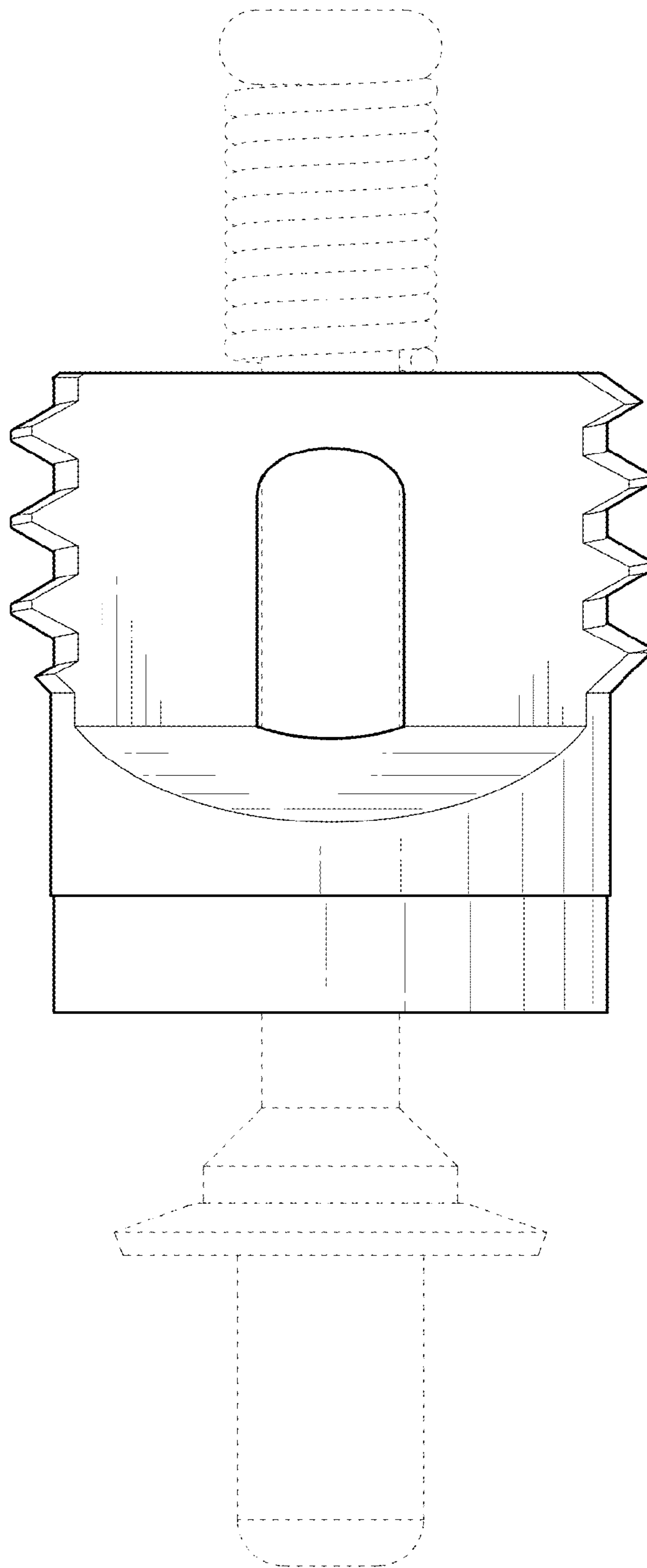

FIG. 10