



US00D989664S

(12) **United States Design Patent** (10) **Patent No.:** **US D989,664 S**  
**Depeyster et al.** (45) **Date of Patent:** **\*\* Jun. 20, 2023**

(54) **VEHICLE FRONT LOWER GRILLE**

FOREIGN PATENT DOCUMENTS

(71) Applicant: **Ford Global Technologies, LLC,**  
Dearborn, MI (US)

CN 307705687 \* 12/2022  
WO D219833-001 \* 4/2022  
WO D219094-003 \* 10/2022

(72) Inventors: **Damon G. Depeyster,** Northville, MI (US); **Sooyoung Kim,** Northville, MI (US); **William J. Mangan,** Ypsilanti, MI (US); **Todd Willing,** Grosse Pointe, MI (US)

OTHER PUBLICATIONS

Compatible For Ford Fusion 2017-2018 Front Bumper Upper & Lower Grille Assembly, available in Amazon.com, date first available Sep. 15, 2019 [online], [site visited Jan. 31, 2023]. Available from the internet URL: [https://www.amazon.com/Fusion-2017-2018-Bumper-Assembly-Replacement/dp/B07XYTX7Q2/ref=sr\\_1\\_18?crid=3L2BPGJR2U](https://www.amazon.com/Fusion-2017-2018-Bumper-Assembly-Replacement/dp/B07XYTX7Q2/ref=sr_1_18?crid=3L2BPGJR2U).\*

(73) Assignee: **Ford Global Technologies, LLC,**  
Dearborn, MI (US)

(\*\*) Term: **15 Years**

(Continued)

(21) Appl. No.: **29/803,448**

*Primary Examiner* — Darlington Ly

*Assistant Examiner* — D. Ryan Tisdale

(22) Filed: **Aug. 12, 2021**

(74) *Attorney, Agent, or Firm* — Vichit Chea

(51) **LOC (14) Cl.** ..... **12-16**

(52) **U.S. Cl.**  
USPC ..... **D12/163**

(58) **Field of Classification Search**  
USPC ..... D12/163, 164, 169–171, 86, 90–92, 190,  
D12/196, 216; D21/533, 548, 552, 561;  
D15/31

CPC ..... B60R 19/00; B60R 19/02; B60R 19/04;  
B60R 19/18; B60R 19/24; B60R 19/26;  
B60R 19/52; B60R 19/56; B60R  
2019/525; B60R 2019/527; B62D 25/084;  
B62D 25/085; B62B 9/16

See application file for complete search history.

(56) **References Cited**

U.S. PATENT DOCUMENTS

2,329,874 A \* 9/1943 Cadwallader ..... B60R 19/48  
180/68.1  
D471,846 S \* 3/2003 Pfeiffer ..... D12/163  
D584,196 S \* 1/2009 Ebel ..... D12/163  
D592,560 S \* 5/2009 Bauer ..... D12/163  
D726,600 S 4/2015 Grake et al.  
D727,223 S 4/2015 Grake et al.  
D824,812 S \* 8/2018 Loeb ..... D12/171  
D824,814 S \* 8/2018 Heyde ..... D12/163

(Continued)

(57) **CLAIM**

The ornamental design for a vehicle front lower grille, as shown and described.

**DESCRIPTION**

FIG. 1 is a front elevational view of a vehicle front lower grille, showing our new design;  
FIG. 2 is a left side elevational view thereof;  
FIG. 3 is a right side elevational view thereof;  
FIG. 4 is a top plan view thereof;  
FIG. 5 is a bottom plan view thereof;  
FIG. 6 is a top, front and left side perspective view thereof;  
and,  
FIG. 7 is a bottom, front and left side perspective view thereof.  
The ghosted or low contrasted structures in the drawings illustrate portions of the vehicle front lower grille that form no part of the claimed design.

**1 Claim, 7 Drawing Sheets**

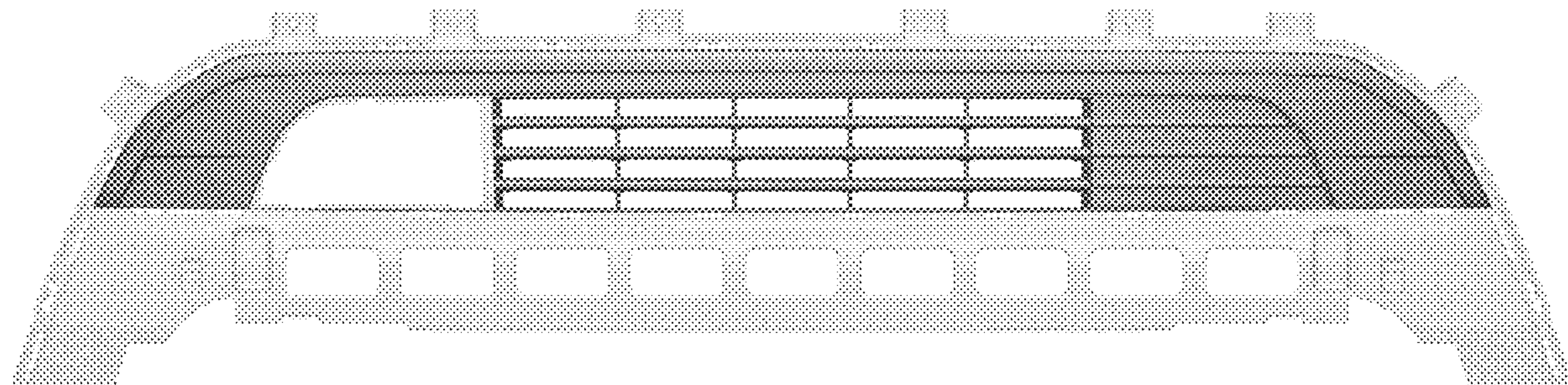

(56)

**References Cited**

U.S. PATENT DOCUMENTS

D825,404 S \* 8/2018 Bucher ..... D12/163  
D875,621 S \* 2/2020 Messale ..... D12/163  
D909,929 S \* 2/2021 Bucher ..... D12/163  
D911,888 S \* 3/2021 Bae ..... D12/169  
D929,273 S \* 8/2021 Piaskowski ..... D12/163  
D937,143 S \* 11/2021 Hamilton ..... D12/163  
2021/0276395 A1 \* 9/2021 Burtch ..... B60H 1/00328

OTHER PUBLICATIONS

Is the 2020 Ford Fusion a Good midsize car with a Great value?,  
announced in YouTube on Dec. 31, 2019 [online], [site visited Jan.  
31, 2023], Available from the internet URL: <https://www.youtube.com/watch?v=qxfY3c4wniU>.\*

2020 Ford Edge Review | A Few Nice Upgrades, announced in  
YouTube on Jun. 16, 2020 [online], [site visited Jan. 31, 2023],  
Available from the internet URL: <https://www.youtube.com/watch?v=vn3lfQxQnfw>.\*

\* cited by examiner



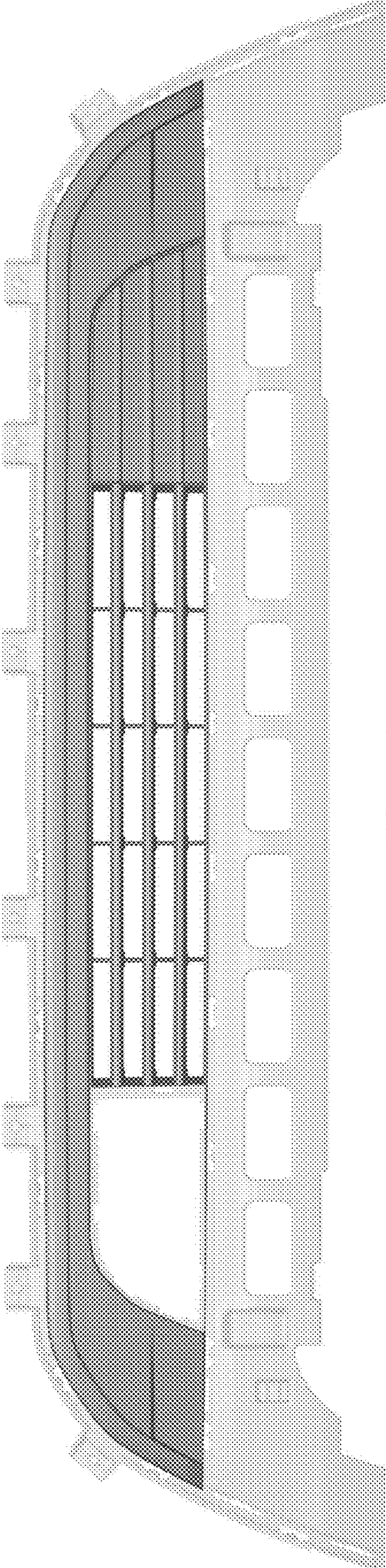

Fig.1

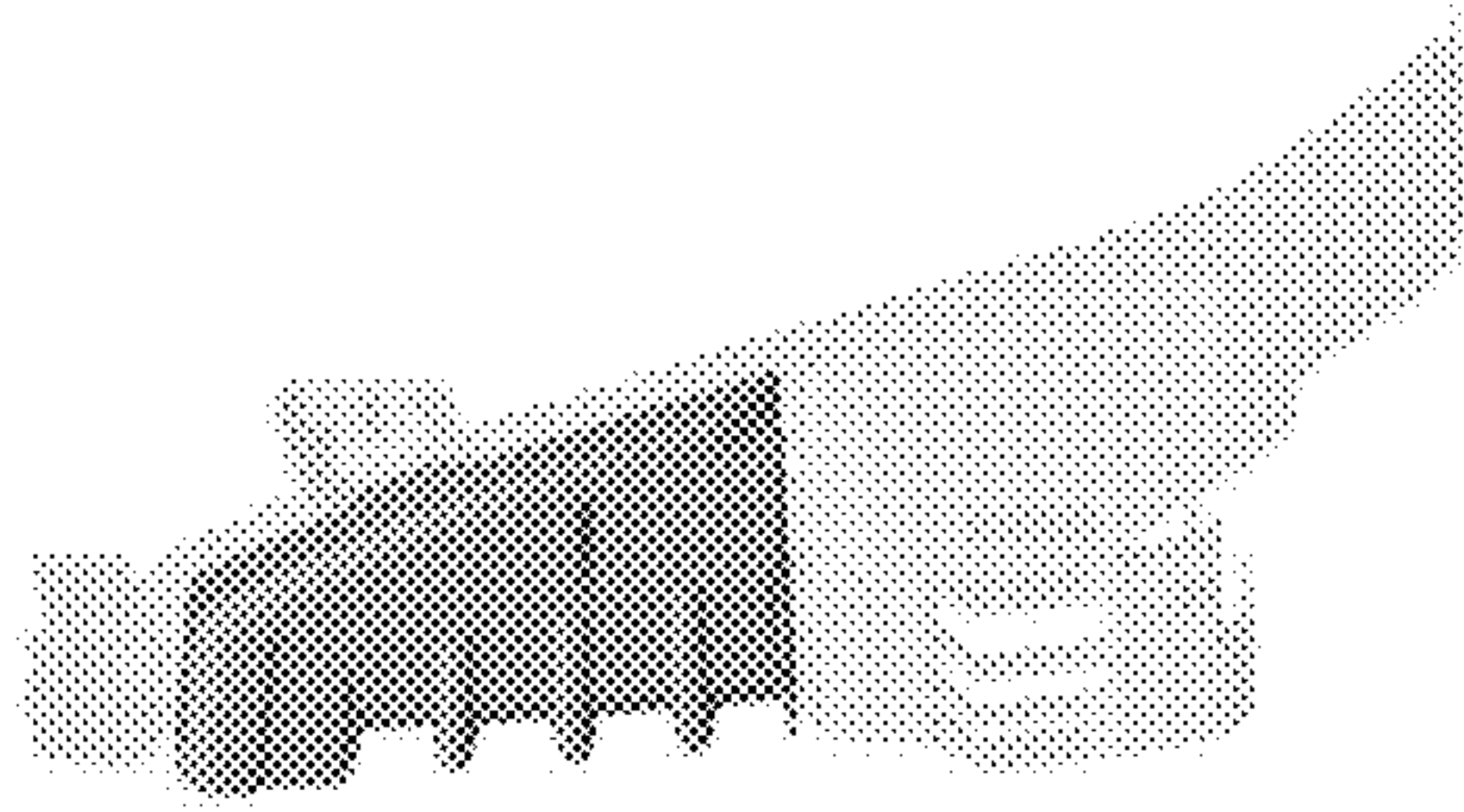

Fig. 2

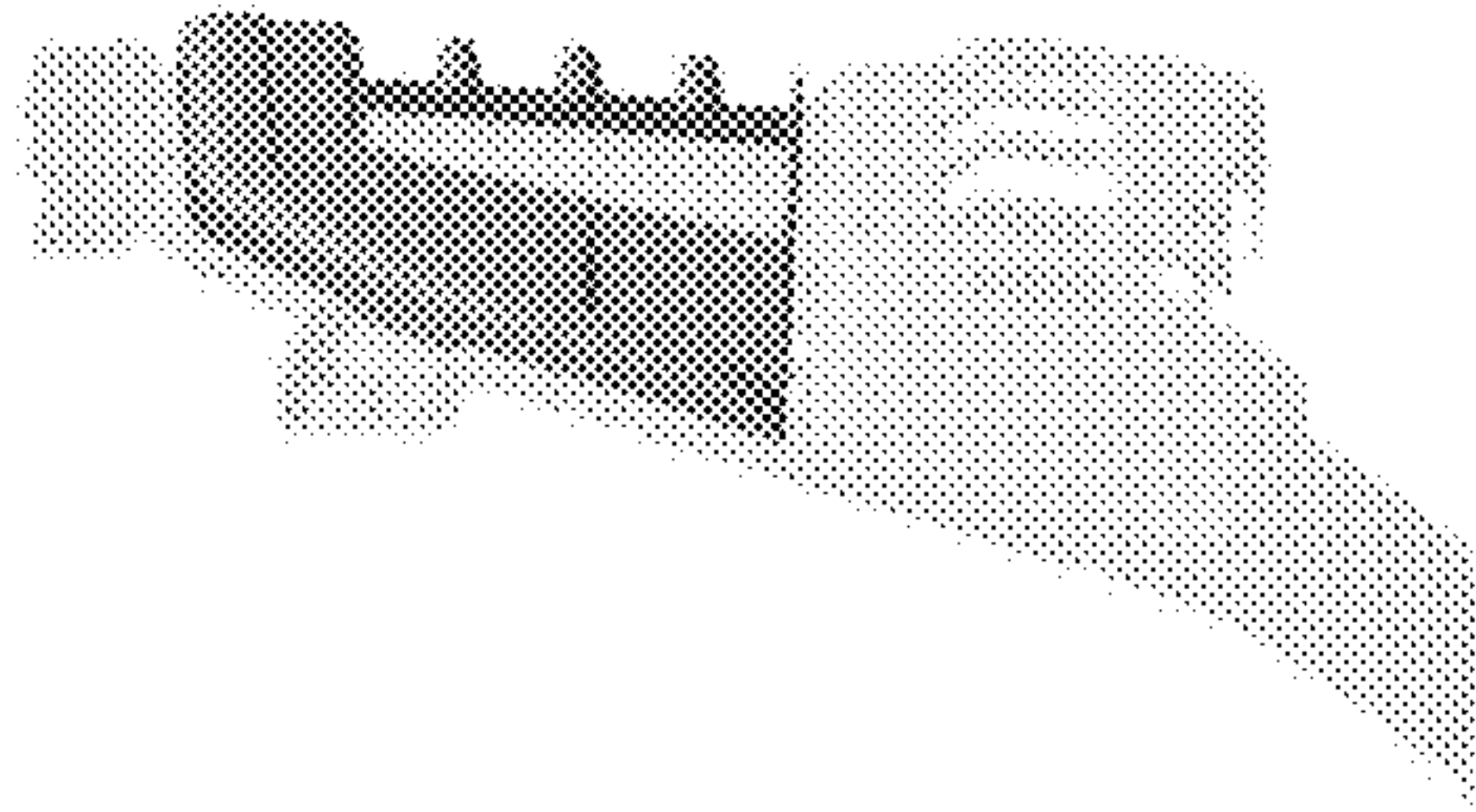

Fig. 3

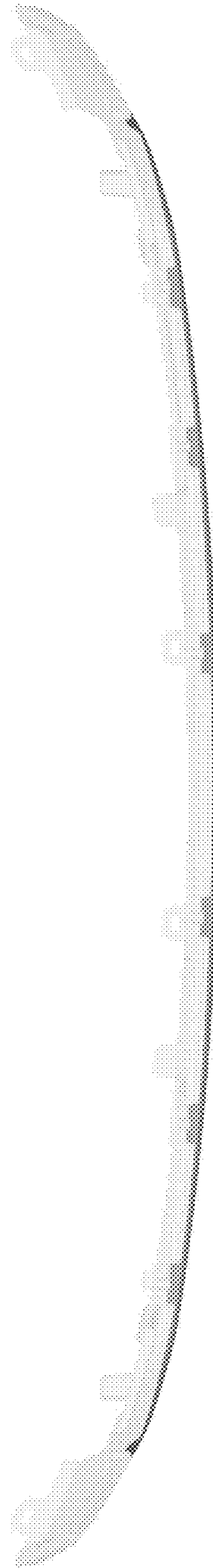

Fig. 4

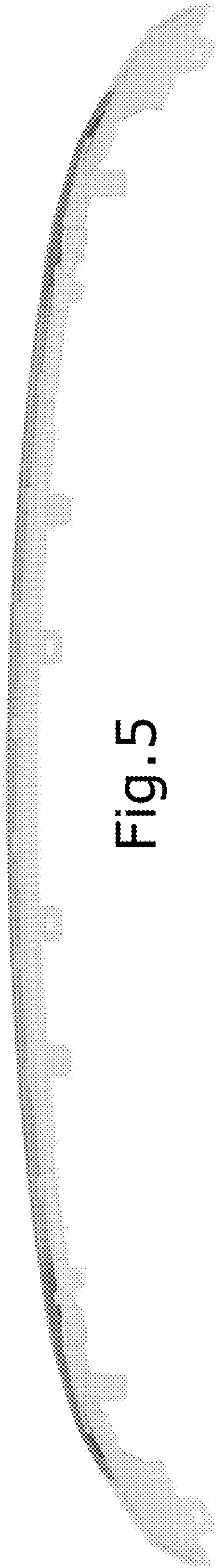

Fig. 5



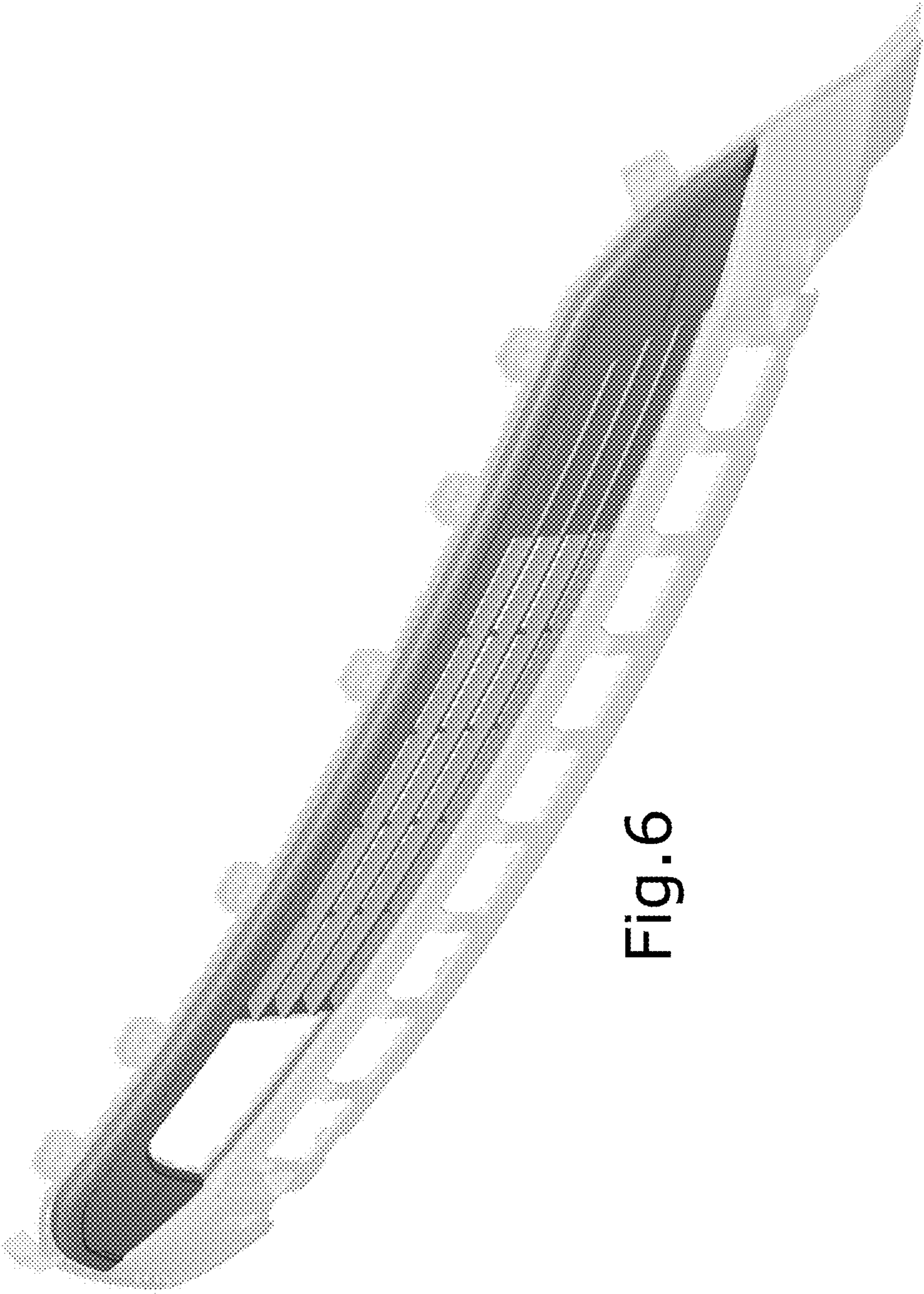

Fig. 6



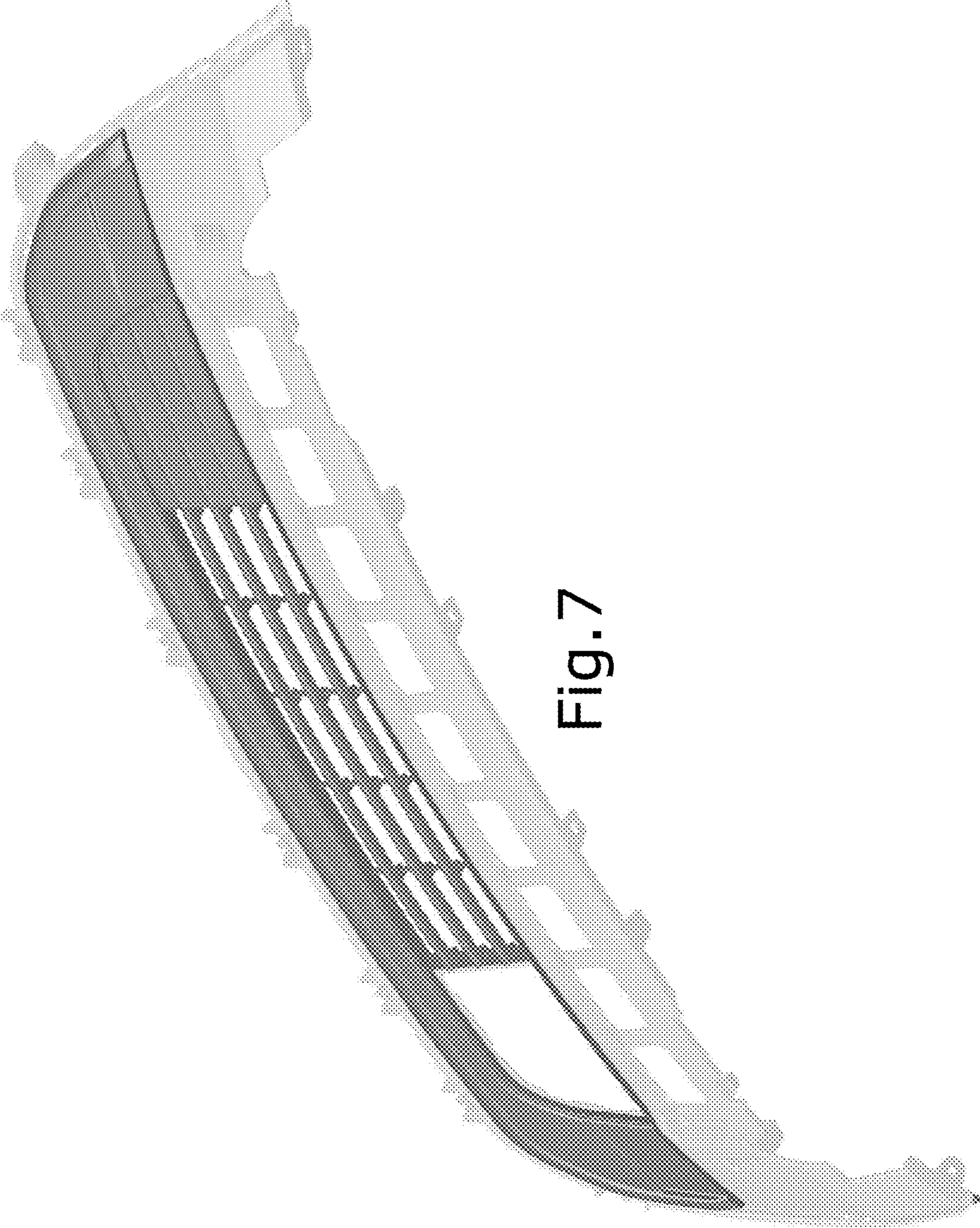

Fig. 7