



US00D989384S

(12) **United States Design Patent** (10) **Patent No.:** **US D989,384 S**
Tidnam et al. (45) **Date of Patent:** **** Jun. 13, 2023**

(54) **AEROSOL GENERATOR**

FOREIGN PATENT DOCUMENTS

(71) Applicant: **Nicoventures Trading Limited**,
London (GB)

AU 95294 S 2/1987
CL 2017003355 A1 6/2018

(Continued)

(72) Inventors: **Matthew Peter Tidnam**, London (GB);
Jay Lee, Seoul (KR); **Ken Kim**,
London (GB); **Marcus Hartley**,
London (GB)

OTHER PUBLICATIONS

Application and File History for U.S. Appl. No. 16/099,294, filed
Nov. 6, 2018, Inventor Thorson.

(Continued)

(73) Assignee: **Nicoventures Trading Limited**,
London (GB)

Primary Examiner — Rebecca Tsehaye

(**) Term: **15 Years**

(74) *Attorney, Agent, or Firm* — Patterson Thuente, P.A.

(21) Appl. No.: **29/781,775**

(22) Filed: **Apr. 30, 2021**

(57) **CLAIM**

(51) **LOC (14) Cl.** **27-02**

We claim the ornamental design for an aerosol generator, as
shown and described.

(52) **U.S. Cl.**

USPC **D27/162**

(58) **Field of Classification Search**

USPC D27/162, 100, 101, 106, 108, 139,
D27/163–165, 172, 183, 185–192, 194;
D24/110, 110.5

CPC A24F 1/30; A24F 1/02; A24F 1/00; A24F
47/008; A24F 47/002

DESCRIPTION

See application file for complete search history.

FIG. 1 is a top perspective view of an aerosol generator.
FIG. 2 is a top view of the aerosol generator depicted in FIG.
1.

(56) **References Cited**

U.S. PATENT DOCUMENTS

174,884 A 3/1876 Wolff
239,198 A 3/1881 Simonds
239,776 A 4/1881 Henley
D22,270 S 3/1893 Marshall
D27,458 S 8/1897 Alexander
844,272 A 2/1907 Fate
912,986 A 2/1909 Aschenbrenner
1,071,817 A 9/1913 Stanley
1,771,366 A 7/1930 Wyss et al.
1,886,391 A 11/1932 Henri et al.
1,927,956 A 9/1933 Samuel et al.
2,104,266 A 1/1938 McCormick

FIG. 3 is a bottom view of the aerosol generator depicted in
FIG. 1.

FIG. 4 is a front view of the aerosol generator depicted in
FIG. 1.

FIG. 5 is a rear view of the aerosol generator depicted in
FIG. 1.

FIG. 6 is a right side view of the aerosol generator depicted
in FIG. 1.

FIG. 7 is a left side view of the aerosol generator depicted
in FIG. 1; and,

FIG. 8 is a bottom perspective view of the aerosol generator
depicted in FIG. 1.

The broken lines in the drawings illustrate portions of the
aerosol generator that form no part of the claimed design.

1 Claim, 8 Drawing Sheets

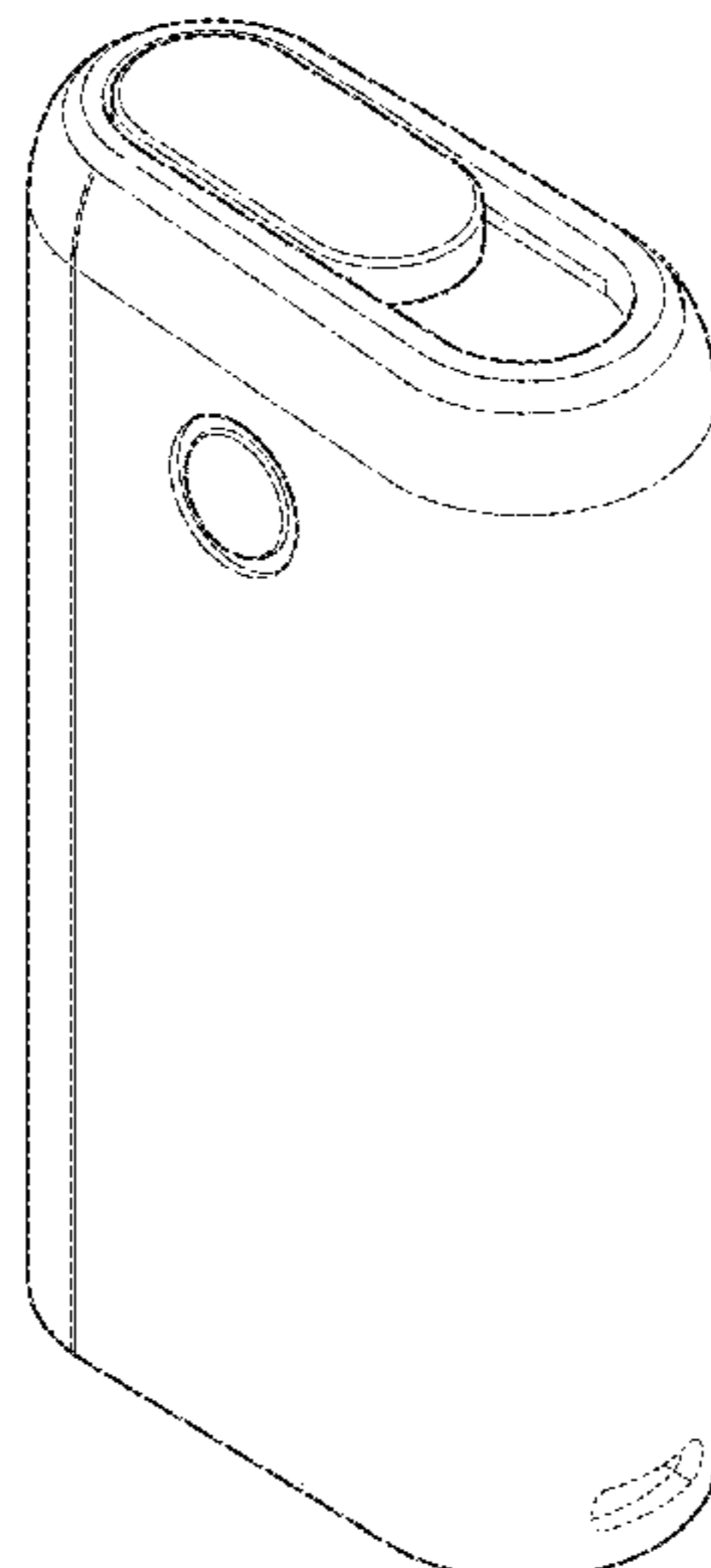

(56)

References Cited

U.S. PATENT DOCUMENTS

2,371,557 A	3/1945	Sullivan	6,026,820 A	2/2000	Baggett, Jr. et al.
D164,391 S	8/1951	Wagner	D422,113 S	3/2000	Higgins et al.
D174,884 S	5/1955	Nelson et al.	6,037,568 A	3/2000	Hatanaka et al.
3,225,954 A	12/1965	Herrick et al.	6,040,560 A	3/2000	Fleischhauer et al.
3,265,236 A	8/1966	Norman et al.	D424,236 S	5/2000	Reed
3,599,646 A	8/1971	Berger et al.	6,089,857 A	7/2000	Matsuura et al.
3,804,100 A	4/1974	Fariello	6,125,853 A	10/2000	Susa et al.
3,805,806 A	4/1974	Grihalva	6,155,268 A	12/2000	Takeuchi
3,889,690 A	6/1975	Guarnieri	6,158,530 A	12/2000	Bowen et al.
D239,198 S	3/1976	Nau	D437,112 S	2/2001	Toffoli
D239,631 S	4/1976	Lauri	D446,849 S	8/2001	Weinberg
D239,776 S	5/1976	Kenjiro	6,315,366 B1	11/2001	Post et al.
4,171,000 A	10/1979	Uhle	6,376,816 B2	4/2002	Cooper et al.
4,214,658 A	7/1980	Crow	6,868,230 B2	3/2005	Gerhardinger
4,226,250 A	10/1980	Ehrenpreis et al.	D506,001 S	6/2005	Christianson
4,253,473 A	3/1981	Marmo et al.	D512,493 S	12/2005	Haranaka
4,303,083 A	12/1981	Burruss, Jr.	6,994,096 B2	2/2006	Rostami et al.
4,474,191 A	10/1984	Steiner	D538,222 S	3/2007	Curello et al.
4,588,976 A	5/1986	Jaselli	D558,060 S	12/2007	Sir
D284,506 S	7/1986	Gutknecht	D558,330 S	12/2007	Chang
4,628,187 A	12/1986	Sekiguchi et al.	7,374,063 B2	5/2008	Reid
4,638,820 A	1/1987	Roberts et al.	D576,718 S	9/2008	Nomi et al.
4,675,508 A	6/1987	Miyaji et al.	7,624,739 B2	12/2009	Snaidr et al.
4,735,217 A	4/1988	Gerth et al.	D620,817 S	8/2010	Eide et al.
4,756,318 A	7/1988	Clearman et al.	D630,592 S	1/2011	Matsuoka
4,765,347 A	8/1988	Sensabaugh, Jr. et al.	D634,417 S	3/2011	Abbondanzio et al.
D301,837 S	6/1989	Peterson et al.	D634,832 S	3/2011	Abbondanzio et al.
D303,766 S	10/1989	Delbanco	7,913,688 B2	3/2011	Cross et al.
4,907,606 A	3/1990	Lilja et al.	D641,196 S	7/2011	Gaydon
4,922,901 A	5/1990	Brooks et al.	D643,732 S	8/2011	Cummings et al.
4,945,929 A	8/1990	Egilmex	7,988,660 B2	8/2011	Byland et al.
4,945,931 A	8/1990	Gori	D645,757 S	9/2011	Milhem et al.
4,947,874 A	8/1990	Brooks et al.	D648,340 S	11/2011	Okura
4,947,875 A	8/1990	Brooks et al.	8,061,361 B2	11/2011	Maeder et al.
5,040,551 A	8/1991	Schlatter et al.	D650,472 S	12/2011	Petersen
5,060,671 A	10/1991	Counts et al.	8,079,371 B2	12/2011	Robinson et al.
5,093,894 A	3/1992	Deevi et al.	8,081,474 B1	12/2011	Zohni et al.
5,095,921 A	3/1992	Losee et al.	D654,160 S	2/2012	Yomtov
5,144,962 A	9/1992	Counts et al.	D657,857 S	4/2012	Choi
5,179,966 A	1/1993	Losee et al.	D663,891 S	7/2012	Cohen Harel
5,190,060 A	3/1993	Gerding et al.	D664,709 S	7/2012	Almsberger et al.
5,203,355 A	4/1993	Clearman et al.	D665,734 S	8/2012	Fitch et al.
5,224,498 A	7/1993	Deevi et al.	D674,479 S	1/2013	Merchant et al.
5,247,947 A	9/1993	Clearman et al.	D677,623 S	3/2013	Fitch et al.
5,249,586 A	10/1993	Morgan et al.	D677,774 S	3/2013	Postma
5,251,688 A	10/1993	Schatz	8,528,780 B2	9/2013	Houghton et al.
5,261,424 A	11/1993	Sprinkel, Jr.	D695,396 S	12/2013	Tani et al.
5,269,327 A	12/1993	Counts et al.	D696,815 S	12/2013	Abroff
5,271,980 A	12/1993	Bell	D700,397 S	2/2014	Manca et al.
5,285,798 A	2/1994	Banerjee et al.	8,678,013 B2	3/2014	Crooks et al.
5,303,720 A	4/1994	Banerjee et al.	D704,319 S	5/2014	Cai
5,322,075 A	6/1994	Deevi et al.	8,757,404 B1	6/2014	Fleckenstein
5,327,915 A	7/1994	Porenski et al.	D708,129 S	7/2014	Houghton et al.
5,331,979 A	7/1994	Henley	D708,727 S	7/2014	Postma
5,345,951 A	9/1994	Serrano et al.	8,807,140 B1	8/2014	Scatterday
5,353,813 A	10/1994	Deevi et al.	8,833,364 B2	9/2014	Buchberger
5,369,723 A	11/1994	Counts et al.	D714,647 S	10/2014	Kersten
5,388,594 A	2/1995	Counts et al.	D715,760 S	10/2014	Kim et al.
5,402,803 A	4/1995	Takagi	D716,267 S	10/2014	Kim et al.
5,408,574 A	4/1995	Deevi et al.	D728,855 S	5/2015	Liu
D360,281 S	7/1995	Kim	D729,366 S	5/2015	Kauss et al.
5,468,936 A	11/1995	Deevi et al.	D729,440 S	5/2015	Liu
5,505,214 A	4/1996	Collins et al.	D729,445 S	5/2015	Leidel
5,564,442 A	10/1996	MacDonald et al.	D732,023 S	6/2015	Asao
5,573,140 A	11/1996	Satomi et al.	D734,395 S	7/2015	Lir et al.
5,613,504 A	3/1997	Collins et al.	D736,455 S	8/2015	Liu
5,613,505 A	3/1997	Campbell et al.	D740,673 S	10/2015	Corradini et al.
5,665,262 A	9/1997	Hajaligol et al.	D743,099 S	11/2015	Oglesby
5,692,291 A	12/1997	Deevi et al.	D743,889 S	11/2015	Lyles et al.
5,708,258 A	1/1998	Counts et al.	D745,404 S	12/2015	Julier et al.
5,771,845 A	6/1998	Pistien et al.	D746,771 S	1/2016	Perez
5,798,154 A	8/1998	Bryan	D748,325 S	1/2016	Leidel
5,865,186 A	2/1999	Volsey, II	D758,656 S	6/2016	Freshwater et al.
5,878,752 A	3/1999	Adams et al.	D759,296 S	6/2016	Abroff et al.
5,954,979 A	9/1999	Counts et al.	D760,414 S	6/2016	Brown et al.
			9,357,803 B2	6/2016	Egoyants et al.
			9,414,629 B2	8/2016	Egoyants et al.
			9,451,792 B1	9/2016	Alima
			D768,834 S	10/2016	Schuller et al.

(56)

References Cited

U.S. PATENT DOCUMENTS

D770,678 S *	11/2016	Shin	D27/163	D905,901 S	12/2020	Kim et al.
D771,867 S	11/2016	Leidel et al.		D908,344 S	1/2021	Jones
D773,114 S	11/2016	Leidel et al.		D908,834 S	1/2021	Cho et al.
9,499,332 B2	11/2016	Fernando et al.		D908,952 S	1/2021	Guo
D775,762 S	1/2017	Chen		D910,231 S	2/2021	Liu et al.
D776,338 S	1/2017	Lomeli		D910,911 S	2/2021	Kim et al.
9,554,598 B2	1/2017	Egoyants et al.		D911,181 S	2/2021	Lee
D778,831 S	2/2017	Chen		D917,777 S	4/2021	Kim et al.
9,609,894 B2	4/2017	Abramov et al.		D924,472 S *	7/2021	Powell D27/162
D787,657 S	5/2017	Farone et al.		D924,473 S *	7/2021	Powell D27/162
D787,728 S	5/2017	Wing et al.		D925,821 S	7/2021	Cruice et al.
D788,364 S *	5/2017	Chen	D27/163	D928,393 S *	8/2021	Powell D27/162
D807,575 S	1/2018	Luo		D929,650 S	8/2021	Cruice et al.
D818,637 S	5/2018	Ringel		D930,893 S *	9/2021	Powell D27/162
D819,023 S	5/2018	Shim		11,134,717 B2	10/2021	Naughton et al.
9,980,523 B2	5/2018	Abramov et al.		11,235,109 B2	2/2022	Thorsen et al.
D821,640 S	6/2018	Qiu		D945,695 S *	3/2022	Powell D27/162
9,999,256 B2	6/2018	Abramov et al.		D953,613 S *	5/2022	Powell D27/162
D824,098 S	7/2018	Scott et al.		D963,239 S	9/2022	Powell et al.
D827,117 S	8/2018	Rigbi		2002/0005207 A1	1/2002	Wrenn et al.
D828,295 S	9/2018	Li		2002/0079309 A1	6/2002	Cox et al.
D828,622 S	9/2018	Chen et al.		2003/0049025 A1	3/2003	Neumann et al.
D828,912 S *	9/2018	Powell	D23/366	2003/0146224 A1	8/2003	Fujii et al.
D828,950 S	9/2018	Gu		2004/0003820 A1	1/2004	Iannuzzi
D828,953 S	9/2018	Chen		2004/0025865 A1	2/2004	Nichols et al.
D829,981 S	10/2018	Chen et al.		2004/0096204 A1	5/2004	Gerhardinger
D833,384 S	11/2018	Takayanagi		2004/0149296 A1	8/2004	Rostami et al.
10,136,679 B1	11/2018	Shotey et al.		2004/0149297 A1	8/2004	Sharpe
D835,857 S	12/2018	Benacquisto et al.		2004/0149737 A1	8/2004	Sharpe et al.
D839,823 S	2/2019	Lemelson et al.		2005/0063686 A1	3/2005	Whittle et al.
10,194,697 B2	2/2019	Fernando et al.		2005/0199610 A1	9/2005	Ptasienski et al.
D842,237 S	3/2019	Qiu et al.		2005/0211711 A1	9/2005	Reid
D842,243 S	3/2019	Qiu		2005/0268911 A1	12/2005	Cross et al.
D843,052 S *	3/2019	Powell	D27/163	2007/0074734 A1	4/2007	Braunshteyn et al.
D844,030 S	3/2019	You		2007/0102013 A1	5/2007	Adams et al.
D848,603 S	5/2019	Fujino et al.		2007/0155255 A1	7/2007	Galauner et al.
D853,022 S	7/2019	Srour		2007/0204858 A1	9/2007	Abelbeck
D854,236 S	7/2019	Qiu		2007/0204868 A1	9/2007	Bollinger et al.
D858,170 S	9/2019	Chan		2007/0283972 A1	12/2007	Monsees et al.
D861,549 S	10/2019	Lai		2008/0029110 A1	2/2008	Dube et al.
D862,794 S	10/2019	Wolk		2008/0085139 A1	4/2008	Roof
D866,853 S	11/2019	Hoashi et al.		2008/0092912 A1	4/2008	Robinson et al.
D869,086 S *	12/2019	Pan	D27/162	2008/0149118 A1	6/2008	Oglesby et al.
D870,367 S	12/2019	Chung et al.		2008/0163879 A1	7/2008	Rodrigues et al.
D872,355 S	1/2020	Powell et al.		2008/0216828 A1	9/2008	Wensley et al.
D872,932 S	1/2020	Powell et al.		2008/0233318 A1	9/2008	Coyle
D876,214 S	2/2020	Yu		2008/0302374 A1	12/2008	Wengert et al.
D878,672 S	3/2020	Beer et al.		2008/0302376 A1	12/2008	Karles et al.
D878,918 S	3/2020	Furner et al.		2009/0032034 A1	2/2009	Steinberg
D881,458 S	4/2020	Ouyang		2009/0056728 A1	3/2009	Baker
D881,459 S *	4/2020	Ouyang	D27/162	2009/0090363 A1	4/2009	Niland et al.
D883,197 S	5/2020	Doucet		2009/0114737 A1	5/2009	Yu et al.
D883,563 S *	5/2020	Pan	D27/139	2009/0126745 A1	5/2009	Hon
D884,266 S	5/2020	Wang		2009/0145448 A1	6/2009	Worlock et al.
D884,961 S	5/2020	He		2009/0151717 A1	6/2009	Bowen et al.
D885,332 S	5/2020	Han		2009/0223514 A1	9/2009	Smith et al.
D885,337 S	5/2020	Xu		2009/0260641 A1	10/2009	Monsees et al.
D885,651 S	5/2020	Miyamoto		2009/0272379 A1	11/2009	Thorens et al.
D888,326 S	6/2020	Qiu		2009/0304372 A1	12/2009	Gubler et al.
D888,329 S	6/2020	Qiu		2010/0126516 A1	5/2010	Yomtov et al.
D889,740 S	7/2020	Beer et al.		2010/0200006 A1	8/2010	Robinson et al.
D891,692 S	7/2020	Barbaric et al.		2010/0218778 A1	9/2010	Borden
D892,124 S	8/2020	Shim		2010/0236561 A1	9/2010	Barnes et al.
D893,009 S	8/2020	Choi		2010/0242975 A1	9/2010	Hearn
D894,476 S	8/2020	Miyamoto		2010/0300467 A1	12/2010	Kuistila et al.
D896,519 S	9/2020	Cooper et al.		2011/0094523 A1	4/2011	Thorens et al.
D897,596 S	9/2020	Huang et al.		2011/0108025 A1	5/2011	Fink et al.
D898,280 S	10/2020	Li et al.		2011/0126848 A1	6/2011	Zuber et al.
D898,990 S	10/2020	Liu et al.		2011/0155153 A1	6/2011	Thorens et al.
D898,991 S	10/2020	Pan		2011/0155718 A1	6/2011	Greim et al.
10,791,765 B2	10/2020	Li et al.		2011/0226236 A1	9/2011	Buchberger
D901,072 S	11/2020	Goradesky		2011/0240047 A1	10/2011	Adamic
D901,762 S	11/2020	Guo		2011/0264084 A1	10/2011	Reid
D904,401 S	12/2020	Wu		2011/0290244 A1	12/2011	Schennum
D904,678 S	12/2020	Wang et al.		2012/0006342 A1	1/2012	Rose et al.
				2012/0255546 A1	10/2012	Goetz et al.
				2012/0260927 A1	10/2012	Liu
				2013/0042865 A1	2/2013	Monsees et al.
				2013/0081623 A1	4/2013	Buchberger

(56)

References Cited

U.S. PATENT DOCUMENTS

2013/0255702 A1 10/2013 Griffith, Jr. et al.
 2013/0298905 A1 11/2013 Levin et al.
 2013/0306084 A1 11/2013 Flick
 2014/0060554 A1 3/2014 Collett et al.
 2014/0069444 A1 3/2014 Cyphert et al.
 2014/0182608 A1 7/2014 Egoiyants et al.
 2014/0182843 A1 7/2014 Vinegar
 2014/0196718 A1 7/2014 Li et al.
 2014/0202476 A1 7/2014 Egoiyants et al.
 2014/0216485 A1 8/2014 Egoiyants et al.
 2014/0270726 A1 9/2014 Egoiyants et al.
 2014/0270727 A1 9/2014 Ampolini et al.
 2014/0283825 A1 9/2014 Buchberger
 2014/0299125 A1 10/2014 Buchberger
 2014/0305449 A1 10/2014 Plojoux et al.
 2014/0326257 A1 11/2014 Jalloul et al.
 2014/0334802 A1 11/2014 Dubief
 2014/0338680 A1 11/2014 Abramov et al.
 2014/0345606 A1 11/2014 Talon
 2014/0360515 A1 12/2014 Vasiliev et al.
 2014/0366898 A1 12/2014 Monsees et al.
 2015/0040925 A1 2/2015 Saleem et al.
 2015/0053217 A1 2/2015 Steingraber et al.
 2015/0059787 A1 3/2015 Qiu
 2015/0101606 A1 4/2015 White
 2015/0101944 A1 4/2015 Li et al.
 2015/0165146 A1 6/2015 Bowman et al.
 2015/0181934 A1 7/2015 Lyubomirskiy et al.
 2015/0181937 A1 7/2015 Dubief et al.
 2015/0189915 A1 7/2015 Liu
 2015/0189919 A1 7/2015 Liu
 2015/0208724 A1 7/2015 Wu
 2015/0208729 A1 7/2015 Monsees et al.
 2015/0223520 A1 8/2015 Phillips et al.
 2015/0237916 A1 8/2015 Farine et al.
 2015/0245658 A1 9/2015 Worm et al.
 2015/0257447 A1 9/2015 Sullivan
 2015/0335071 A1 11/2015 Brinkley et al.
 2016/0003403 A1 1/2016 Smith
 2016/0007652 A1 1/2016 Taluskie et al.
 2016/0081395 A1 3/2016 Thorens et al.
 2016/0088875 A1 3/2016 Egoiyants et al.
 2016/0198771 A1 7/2016 Goggin et al.
 2016/0255879 A1 9/2016 Paprocki et al.
 2016/0286865 A1 10/2016 King et al.
 2016/0366937 A1 12/2016 Liu
 2017/0042227 A1 2/2017 Gavriellov et al.
 2017/0119048 A1 5/2017 Kaufman et al.
 2017/0119049 A1 5/2017 Blandino et al.
 2017/0119050 A1 5/2017 Blandino et al.
 2017/0156406 A1 6/2017 Abramov et al.
 2017/0156407 A1 6/2017 Abramov et al.
 2017/0197043 A1 7/2017 Buchberger
 2017/0197044 A1 7/2017 Buchberger
 2017/0197046 A1 7/2017 Buchberger
 2017/0231276 A1 8/2017 Mironov et al.
 2017/0231282 A1 8/2017 Bowen et al.
 2017/0232211 A1 8/2017 Gallem et al.
 2018/0000160 A1 1/2018 Taschner et al.
 2018/0020728 A1 1/2018 Alarcon et al.
 2018/0161525 A1 6/2018 Liu et al.
 2018/0168224 A1 6/2018 Naughton et al.
 2018/0271151 A1 9/2018 Litten
 2018/0271153 A1 9/2018 John et al.
 2018/0271171 A1 9/2018 Abramov et al.
 2019/0029326 A1 1/2019 Qiu
 2019/0046745 A1 2/2019 Nettenstrom et al.
 2019/0069599 A1 3/2019 Monsees et al.
 2019/0150508 A1 5/2019 Thorsen et al.
 2019/0166918 A1 6/2019 Thorsen et al.
 2019/0200678 A1 7/2019 Thorson et al.
 2019/0208815 A1 7/2019 Thorsen
 2019/0208816 A1 7/2019 Thorsen
 2019/0208817 A1 7/2019 Qiu et al.
 2019/0246693 A1 8/2019 Nettenstrom et al.

2019/0314586 A1 10/2019 Minskoff
 2019/0387799 A1 12/2019 Reeve
 2020/0187555 A1 6/2020 Lee
 2020/0221778 A1 7/2020 Trzeciecki
 2020/0221782 A1 7/2020 Lim
 2020/0245681 A1 8/2020 An
 2020/0253280 A1 8/2020 Thorsen
 2020/0345075 A1 11/2020 Hepworth
 2020/0345960 A1 11/2020 Begin et al.
 2020/0359706 A1 11/2020 Liu
 2021/0000169 A1 1/2021 Hepworth
 2021/0007401 A1 1/2021 Moloney et al.
 2021/0015160 A1* 1/2021 Moloney A24F 40/57
 2021/0015161 A1 1/2021 Moloney et al.
 2021/0015162 A1 1/2021 Moloney et al.

FOREIGN PATENT DOCUMENTS

CN 86102917 A 11/1987
 CN 1040914 A 4/1990
 CN 1045691 A 10/1990
 CN 1122213 A 5/1996
 CN 1126425 A 7/1996
 CN 2246744 Y 2/1997
 CN 1190335 A 8/1998
 CN 1196660 A 10/1998
 CN 1196661 A 10/1998
 CN 1333657 A 1/2002
 CN 2598364 Y 1/2004
 CN 1633247 A 6/2005
 CN 1947462 A 4/2007
 CN 101044795 A 9/2007
 CN 101238047 A 8/2008
 CN 101267749 A 9/2008
 CN 101277622 A 10/2008
 CN 201185656 Y 1/2009
 CN 101557728 A 10/2009
 CN 201375023 Y 1/2010
 CN 101843368 A 9/2010
 CN 101925309 A 12/2010
 CN 201869778 U 6/2011
 CN 102595943 A 7/2012
 CN 102753047 A 10/2012
 CN 202819632 U 3/2013
 CN 103359550 A 10/2013
 CN 103763953 A 4/2014
 CN 103763954 A 4/2014
 CN 203662020 U 6/2014
 CN 103919279 A 7/2014
 CN 103974639 A 8/2014
 CN 104095293 A 10/2014
 CN 203952426 U 11/2014
 CN 104219973 A 12/2014
 CN 104256898 A 1/2015
 CN 104394721 A 3/2015
 CN 104768407 A 7/2015
 CN 104770894 A 7/2015
 CN 104770895 A 7/2015
 CN 204499486 U 7/2015
 CN 104957779 A 10/2015
 CN 105361249 A 3/2016
 CN 105407748 A 3/2016
 CN 205072071 U 3/2016
 CN 105795503 A 7/2016
 CN 303798113 S 8/2016
 CN 304035109 S 2/2017
 CN 304590373 S 4/2018
 CN 304659647 6/2018
 CN 304659654 6/2018
 CN 304691359 6/2018
 CN 304696494 6/2018
 CN 304724787 7/2018
 CN 304840668 10/2018
 CN 304854337 10/2018
 CN 304935891 12/2018
 CN 305060127 3/2019
 CN 305162683 5/2019
 CN 305475358 12/2019
 CN 305737626 4/2020

(56)

References Cited

FOREIGN PATENT DOCUMENTS			
DE	29713866	U1	10/1997
DE	19854005	A1	5/2000
DE	19854009	A1	5/2000
EM	0026114260001		3/2015
EM	EU0027270990001		9/2017
EM	EU0027270990007		9/2017
EM	002880088-0006		5/2018
EM	0029810430001		5/2018
EP	0358002	A2	3/1990
EP	0358114	A2	3/1990
EP	0430559	A2	6/1991
EP	0430566	A2	6/1991
EP	0438862	A2	7/1991
EP	0488488	A1	6/1992
EP	0503767	A1	9/1992
EP	0603613	A1	6/1994
EP	0845220	A1	6/1998
EP	1618803	A1	1/2006
EP	1736065	A1	12/2006
EP	2022349	A1	2/2009
EP	2110033	A1	10/2009
EP	1947965	B1	2/2010
EP	2316286	A1	5/2011
EP	2327318	A1	6/2011
EP	2340729	A1	7/2011
EP	2340730	A1	7/2011
EP	2394520	A1	12/2011
EP	2520186	A1	11/2012
EP	2797448	A2	11/2014
EP	2984946	A1	2/2016
EP	2787846	B1	3/2016
GB	191000639	A	12/1910
GB	191126138	A	3/1912
GB	426247	A	3/1935
JP	S62501050	A	4/1987
JP	S63127399	U	8/1988
JP	H03108472	A	5/1991
JP	H03192677	A	8/1991
JP	H03232481	A	10/1991
JP	H05212100	A	8/1993
JP	H0590161	U	12/1993
JP	H06189861	A	7/1994
JP	H06315366	A	11/1994
JP	H07184627	A	7/1995
JP	H08942	U	6/1996
JP	H08511176	A	11/1996
JP	H09107943	A	4/1997
JP	H1189551	A	4/1999
JP	H11125390	A	5/1999
JP	H11169157	A	6/1999
JP	2001521123	A	11/2001
JP	3392138	B2	3/2003
JP	2003527127	A	9/2003
JP	2005036897	A	2/2005
JP	2005106350	A	4/2005
JP	2005300005	A	10/2005
JP	2006501871	A	1/2006
JP	2006223158	A	8/2006
JP	2008249003	A	10/2008
JP	2009509521	A	3/2009
JP	2009537120	A	10/2009
JP	2010506594	A	3/2010
JP	2010178730	A	8/2010
JP	2010213579	A	9/2010
JP	2011058538	A	3/2011
JP	2011509667	A	3/2011
JP	2013509160	A	3/2013
JP	5193668	B2	5/2013
JP	5510968	B2	6/2014
JP	2014519586	A	8/2014
JP	2014522650	A	9/2014
JP	2014524313	A	9/2014
JP	2014525251	A	9/2014
JP	2014533513	A	12/2014
JP	5670437	B2	2/2015
JP	2015513922	A	5/2015
JP	2015519915	A	7/2015
JP	2015521847	A	8/2015
JP	2015531600	A	11/2015
JP	2016534730	A	11/2016
JP	6273586	B2	2/2018
JP	D1596828	S	2/2018
JP	D1611654		7/2018
JP	6539756	B2	7/2019
JP	6764505	B2	9/2020
KR	0178388	B1	2/1999
KR	19990081973	A	11/1999
KR	20010089445	A	10/2001
KR	100304044	B1	11/2001
KR	100404704	B1	10/2004
KR	100495099	B1	11/2005
KR	100636287	B1	10/2006
KR	100757450	B1	9/2007
KR	20070108215	A	11/2007
KR	20080060218	A	7/2008
KR	20100035492	A	4/2010
KR	20100135865	A	12/2010
KR	20120104533	A	9/2012
KR	20150129683	A	11/2015
KR	20160031801	A	3/2016
RU	2600092	C2	10/2016
RU	102379	S	3/2017
WO	WO-8602528	A1	5/1986
WO	WO-9219081	A1	10/1992
WO	WO-9406314	A1	3/1994
WO	WO-9418860	A1	9/1994
WO	WO-9527412	A1	10/1995
WO	WO-9632854	A2	10/1996
WO	WO-9741744	A1	11/1997
WO	WO-9748295	A1	12/1997
WO	WO-9823171	A1	6/1998
WO	WO-9920939	A1	4/1999
WO	WO-0027232	A1	5/2000
WO	WO-0167819	A1	9/2001
WO	WO-0170054	A1	9/2001
WO	WO-03012565	A1	2/2003
WO	WO-03037412	A2	5/2003
WO	WO-03056948	A1	7/2003
WO	WO-03059413	A2	7/2003
WO	WO-03070031	A1	8/2003
WO	WO-03103387	A2	12/2003
WO	WO-2007012007	A2	1/2007
WO	WO-2007017482	A1	2/2007
WO	WO-2007039794	A2	4/2007
WO	WO-2007131450	A1	11/2007
WO	WO-2008108889	A1	9/2008
WO	WO-2008121610	A1	10/2008
WO	WO-2009001082	A1	12/2008
WO	WO-2009022232	A2	2/2009
WO	WO-2009092862	A1	7/2009
WO	WO-2010047389	A1	4/2010
WO	WO-2010073018	A1	7/2010
WO	WO-2010107613	A1	9/2010
WO	WO-2010118644	A1	10/2010
WO	WO-2010133342	A1	11/2010
WO	WO-2011050964	A1	5/2011
WO	WO-2011063970	A1	6/2011
WO	WO-2011068020	A1	6/2011
WO	WO-2011079932	A1	7/2011
WO	WO-2011118024	A1	9/2011
WO	WO-2013022936	A1	2/2013
WO	WO-2013025921	A1	2/2013
WO	WO-2013034454	A1	3/2013
WO	WO-2013034458	A1	3/2013
WO	WO-2013034459	A1	3/2013
WO	WO-2013034460	A1	3/2013
WO	WO-2013076098	A2	5/2013
WO	WO-2013098395	A1	7/2013
WO	WO-2013098396	A2	7/2013
WO	WO-2013098397	A2	7/2013
WO	WO-2013131764	A1	9/2013
WO	WO-2013160112	A2	10/2013
WO	WO-2014047954	A1	4/2014
WO	WO-2014201432	A1	12/2014

(56)

References Cited

FOREIGN PATENT DOCUMENTS

WO	WO-2015062983	A2	5/2015
WO	WO-2015091258	A1	6/2015
WO	WO-2015097187	A1	7/2015
WO	WO-2015166245	A2	11/2015
WO	WO-2015177254	A1	11/2015
WO	WO-2015193456	A1	12/2015
WO	WO-2016012774	A1	1/2016
WO	WO-2016207407	A1	12/2016
WO	WO-2017186946	A1	11/2017
WO	WO-2017194762	A1	11/2017
WO	WO-2017194763	A2	11/2017
WO	WO-2017194764	A1	11/2017
WO	WO-2017194766	A1	11/2017
WO	WO-2017194769	A1	11/2017
WO	WO-2017198874	A1	11/2017
WO	WO-2018019786	A1	2/2018
WO	WO-D200284-003		8/2020

OTHER PUBLICATIONS

Application and File History for U.S. Appl. No. 16/099,309, filed Nov. 6, 2018, inventors Michaud, et al.

Application and File History for U.S. Appl. No. 29/676,726, filed Jan. 14, 2019, 98 pages, inventor(s): Powell et al.

Application and File History for U.S. Appl. No. 16/099,315, filed Nov. 6, 2018, Inventor: Thorsen. 222 pages.

Application and File History for U.S. Appl. No. 13/583,381, filed Dec. 17, 2012, inventor Buchberger.

Application and File History for U.S. Appl. No. 14/127,138, filed Feb. 10, 2014, inventors Egoiyants et al.

Application and File History for U.S. Appl. No. 14/127,144, filed Mar. 31, 2014, inventors Egoiyants et al.

Application and File History for U.S. Appl. No. 14/127,148, filed Mar. 12, 2014, inventors Egoiyants et al.

Application and File History for U.S. Appl. No. 14/127,879, filed May 9, 2014, inventors Egoiyants et al.

Application and File History for U.S. Appl. No. 14/343,368, filed Jun. 24, 2014, inventors Abramov et al.

Application and File History for U.S. Appl. No. 14/382,198, filed Aug. 29, 2014, inventors Saleem et al.

Application and Filing Receipt for U.S. Appl. No. 29/557,914, filed Mar. 14, 2016, 280 pages, inventor(s): Powell et al.

Chinese Search Report, Application No. 201780022480.3, dated Jul. 8, 2021, 2 pages.

Collier J.G et al., "10.3 Mechanism of Evaporation and Condensation," Convective Boiling and Condensation, Third Edition, Clarendon Press, 1994, 6 pages.

Communication pursuant to Article 94(3) EPC for Application No. 17726217.7 dated Nov. 17, 2020, 5 pages.

Communication pursuant to Article 94(3) EPC for Application No. 17726220.1 dated Dec. 23, 2021, 6 pages.

Communication pursuant to Article 94(3) EPC for Application No. 17726220.1 dated Oct. 8, 2020, 6 pages.

Concept Group, "Insulon® Thermal Barrier from Concept Group Blocks Heat with HyperDeep Vacuum™," Dec. 15, 2011, 1 page.

Davies, et al., "Metallic Foams: Their Production, Properties and Applications," Journal of Materials Science, 1983, vol. 18(7), pp. 1899-1911.

Decision of Refusal dated Jun. 22, 2021 for Japanese Application No. 2018-551932, 11 pages.

Decision to Grant a Patent dated Nov. 15, 2016 for Japanese Application No. 2015-506185 filed Apr. 11, 2013, 5 pages.

Decision to Grant a Patent dated Jun. 7, 2022 for Japanese Application No. 2020-185086, 5 pages.

Decision to Grant a Patent dated Apr. 12, 2022 for Japanese Application No. 2020-152565, 5 pages.

Decision to Grant dated Jan. 18, 2017 for Russian Application No. 2016503074, 4 pages.

English Translation of Office Action dated Dec. 25, 2018 for Korean Application No. ID-2017-7037332, 7 pages.

European Search Report for Application No. 21212962.1, dated on Mar. 17, 2022, 6 pages.

Examination Report dated Jan. 9, 2019 for Philippines Application No. 1/2016/500805, 6 pages.

Examination Report dated Feb. 21, 2018 for Australian Application No. 2016204192, 7 pages.

Extended European Search Report for Application No. 21165527.9, dated on Jul. 23, 2021, 13 pages.

Extended European Search Report for Application No. 21197532.1, dated on Apr. 11, 2022, 8 pages.

First Office Action dated Aug. 14, 2020 for Chinese Application No. 201780028361.9, 15 pages.

First Office Action dated Jun. 15, 2015 and Search Report dated Jun. 2, 2015 for Chinese Application No. 201280029784.X, filed Aug. 24, 2012, 27 pages.

First Office Action dated Dec. 3, 2015 for Chinese Application No. 201380021387.2, filed Apr. 11, 2011, 20 pages.

FlowerMate Vopormax-V Portable Marijuana Vaporizer Shown at: https://www.youtube.com/watch?v=S3bAYHif_i4, Aug. 22, 2014, 1 page.

GB Search Report for Application No. 1808526.6 dated Nov. 14, 2018, 1 Page.

Glo E-cigarette, published 2016 [online], [retrieved Dec. 5, 2020], Available from Internet, URL: <https://ifworlddesignguide.com/entry/235574-glo>.

"Glo E-cigarette", published 2016, retrieved from <https://ifworlddesignguide.com/entry/235574-glo> on 12/May 2020, 4 pages.

Goboof Alfa Shown at: <https://www.youtube.com/watch?v=l39A9OXp-yl>, Nov. 22, 2014, 1 page.

"Handbook of Advanced Robotics", [US] E. L. Safford, Translated by Li, Deming et al., Shanghai Translation Publishing Company, Mar. 1987, 1st edition, pp. 162-163.

U.S. Appl. No. 29/722,522, filed Jan. 30, 2020, 74 pages, inventor(s): Cruice et al.

U.S. Appl. No. 29/722,523, filed Jan. 30, 2020, 74 pages, inventor(s): Cruice et al.

U.S. Appl. No. 29/722,527, filed Jan. 30, 2020, 86 pages, inventor(s): Cruice et al.

U.S. Appl. No. 29/722,528, filed Jan. 30, 2020, 86 pages, inventor(s): Cruice et al.

U.S. Appl. No. 29/722,529, filed Jan. 30, 2020, 73 pages, inventor(s): Cruice et al.

U.S. Appl. No. 29/722,530, filed Jan. 30, 2020, 46 pages, inventor(s): Cruice et al.

U.S. Appl. No. 29/722,531, filed Jan. 30, 2020, 46 pages, inventor(s): Cruice et al.

U.S. Appl. No. 29/557,914, filed Mar. 14, 2016, 284 pages, inventor(s): Powell et al.

U.S. Appl. No. 29/652,976, filed Jan. 27, 2021, 29 pages, inventor(s): Cruice et al.

U.S. Appl. No. 29/676,726, filed Jan. 14, 2019, 233 pages, inventor(s): Powell et al.

U.S. Appl. No. 29/687,461, filed Apr. 12, 2019, 185 pages, inventor(s): Powell et al.

U.S. Appl. No. 29/687,464, filed Apr. 12, 2019, 176 pages, inventor(s): Powell et al.

U.S. Appl. No. 29/687,469, filed Apr. 12, 2019, 147 pages, inventor(s): Powell et al.

U.S. Appl. No. 29/687,471, filed Apr. 12, 2019, 222 pages, inventor(s): Powell et al.

Design U.S. Appl. No. 29/705,487, filed Sep. 12, 2019 inventor(s): Powell et al., 162 pages.

U.S. Appl. No. 15/737,673, filed Dec. 18, 2017, inventor(s): Thorsen et al., 205 pages.

International Preliminary Report on Patentability for Application No. PCT/EP2012/066484, dated Mar. 20, 2014, 7 pages.

International Preliminary Report on Patentability for Application No. PCT/EP2017/061518, dated Aug. 17, 2018, 16 pages.

International Preliminary Report on Patentability for Application No. PCT/EP2017/061519, dated Jul. 25, 2018, 22 pages.

International Preliminary Report on Patentability for Application No. PCT/EP2017/061520, dated Jul. 17, 2018, 11 pages.

(56)

References Cited

OTHER PUBLICATIONS

International Preliminary Report on Patentability for Application No. PCT/EP2017/061526, dated Nov. 22, 2018, 10 pages.

International Preliminary Report on Patentability for Application No. PCT/EP2017/068675, dated Nov. 29, 2018, 7 pages.

International Preliminary Report on Patentability for International Application No. PCT/EP2017/061520, dated Jul. 17, 2018, 11 pages.

International Preliminary Report on Patentability for International Application No. PCT/EP2017/061523, dated Jul. 23, 2018, 14 pages.

International Preliminary Report on Patentability for Application No. PCT/EP2012/066486, dated Oct. 22, 2013, 10 pages.

International Preliminary Report on Patentability for Application No. PCT/EP2012/066523, dated Nov. 4, 2013, 9 pages.

International Preliminary Report on Patentability for Application No. PCT/EP2012/066524, dated Oct. 17, 2013, 11 pages.

International Preliminary Report on Patentability for Application No. PCT/EP2016/064756, dated Sep. 28, 2017, 9 pages.

International Search Report and Written Opinion for Application No. PCT/EP2013/057539, dated Feb. 11, 2014, 16 pages.

International Search Report and Written Opinion for Application No. PCT/EP2017/061519, dated Dec. 15, 2017, 22 pages.

International Search Report and Written Opinion for Application No. PCT/EP2017/061520, dated Sep. 11, 2017, 13 pages.

International Search Report and Written Opinion for Application No. PCT/EP2017/061523, dated Sep. 11, 2017, 13 pages.

International Search Report and Written Opinion for Application No. PCT/EP2017/068675, dated Nov. 9, 2017, 15 pages.

International Search Report and Written Opinion for Application No. PCT/EP2019/063501, dated Sep. 18, 2019, 13 pages.

International Search Report and Written Opinion for International Application No. PCT/EP2017/061520, dated Sep. 11, 2017, 9 pages.

International Search Report and Written Opinion for Application No. PCT/EP2012/066484, dated Jan. 9, 2013, 9 pages.

International Search Report and Written Opinion for Application No. PCT/EP2012/066486, dated Jan. 14, 2013, 8 pages.

International Search Report and Written Opinion for Application No. PCT/EP2012/066523, dated Jan. 9, 2013, 9 pages.

International Search Report and Written Opinion for Application No. PCT/EP2012/066524, dated Jan. 9, 2013, 8 pages.

International Search Report and Written Opinion for Application No. PCT/EP2012/066525, dated Jan. 9, 2013, 10 pages.

International Search Report and Written Opinion for Application No. PCT/EP2012/066485, dated Dec. 10, 2012, 10 pages.

International Search Report and Written Opinion for Application No. PCT/AT2011/000123, dated Jul. 18, 2011, 8 pages.

International Search Report for Application No. PCT/EP2016/064756, dated Oct. 5, 2016, 2 pages.

International Search Report for Application No. PCT/EP2017/061518, dated Aug. 1, 2017, 4 pages.

International Search Report for Application No. PCT/EP2017/061526, dated Aug. 2, 2017, 4 pages.

National Plastic Heater, Sensor and Control Inc., "Kapton (Polyimide) Flexible Heaters," 2011, retrieved from https://www.kapton-silicone-flexible-heaters.com/products/kapton_polyimide_flexible_heaters.html on Feb. 23, 2018, 2 pages.

Notice of Opposition dated Mar. 7, 2017 for European Application No. 12750770.5, 22 pages.

Notice of Opposition dated Jun. 28, 2022 for European Application No. 16738688.7 (EP3313217), 20 pages.

Notice Of Reason for Refusal for Japanese Application No. 2018-551932 dated Oct. 6, 2020, 8 pages.

Notice Of Reasons for Refusal for Japanese Application No. 2020-152565 dated Jun. 29, 2021, 5 pages.

Notice Of Reasons for Refusal for Japanese Application No. 2020-152565 dated Nov. 24, 2021, 12 pages.

Notice of Reasons for Refusal for Japanese Application No. 2020-185086, dated Jan. 4, 2022, 8 pages.

Notice of Reasons for Refusal dated Nov. 20, 2018 for Japanese Application No. 2017-567106, 6 pages.

Notice of Reasons for Rejection for Japanese Application No. 2020-121968, dated Jun. 15, 2021, 8 pages.

Office Action dated Jul. 8, 2016 for Chinese Application No. 201380021387.2, filed Apr. 11, 2011, 12 pages.

Office Action dated Sep. 25, 2018 for European Application No. 12750765.5 filed Aug. 24, 2012, 22 pages.

Office Action dated Sep. 26, 2018 for European Application No. 12750765.5 filed Aug. 24, 2012, 67 pages.

Office Action dated Sep. 29, 2015 for Japanese Application No. 2015-506185 filed Apr. 11, 2013, 5 pages.

Office Action dated Mar. 31, 2015 for Japanese Application No. 2014-519585 filed Aug. 24, 2012, 8 pages.

Office Action dated Apr. 7, 2015 for Japanese Application No. 2014-519586 filed Aug. 24, 2012, 10 pages.

Office Action and Search Report mailed Apr. 27, 2015 for Chinese Application No. 201280030681.5, filed Aug. 24, 2012, 25 pages.

Office Action dated Jul. 13, 2020 for Chinese Application No. 201780026927.4, 15 pages.

Office Action dated Jul. 22, 2020 for Chinese Application No. 2017800293080.0 filed May 12, 2017, 14 pages.

Office Action dated May 25, 2021 for Ukraine Application No. 201811040, 2 pages.

Office Action for Brazilian Application No. 112017027824-3, dated Jan. 9, 2022, 6 pages.

Office action for Brazilian Application No. 112018072732-6, dated Sep. 28, 2021, 4 pages.

Office action for Brazilian Application No. 112018073458-6, dated Sep. 28, 2021, 4 pages.

Office Action For Canadian Application No. 2,989,260, dated Jun. 18, 2021, 3 pages.

Office Action for Chinese Application No. 201780022480.3, dated Feb. 10, 2022, 7 pages.

Office Action for Chinese Application No. 201780022480.3, dated Jul. 8, 2021, 13 pages.

Office Action For Chinese Application No. 201780022480.3, dated Mar. 2, 2021, 6 pages.

Office Action for Chinese Application No. 201780026927.4, dated Dec. 14, 2020, 5 pages.

Office Action for Japanese Application No. 2019-020616, dated Jan. 17, 2022, 2 pages.

Office Action for Japanese Application No. 2020-185087, dated Feb. 1, 2022, 7 pages.

Office Action for Japanese Application No. 2021-200209, dated Mar. 15, 2022, 5 pages.

Office Action For Korean Application No. 10-2018-7032766, dated Dec. 28, 2020, 10 pages.

Office Action For Korean Application No. 10-2018-7032766, dated Jul. 23, 2021, 8 pages.

Office Action For Korean Application No. 10-2018-7032766, dated Sep. 29, 2021, 11 pages.

Office Action For Korean Application No. 10-2019-0061281, dated Jun. 29, 2021, 14 pages.

Office Action For Korean Application No. 10-2019-7027490, dated Sep. 1, 2021, 12 pages.

Office Action for Korean Application No. 10-2021-7033822, dated Jan. 24, 2022, 6 pages.

Office Action for Malaysian Application No. PI2018703432, dated Aug. 30, 2021, 4 pages.

Office Action for Malaysian Application No. PI2018704088, dated May 31, 2022, 4 pages.

Office Action for Malaysian Application No. PI2019000241, dated Apr. 18, 2022, 3 pages.

Office Action For Russian Application No. 201811038, dated Aug. 26, 2021, 7 pages.

Office Action for Russian Application No. 2020500358, dated Aug. 27, 2020, 10 pages.

Office Action For Russian Application No. 2020500360, dated Aug. 27, 2020, 11 pages.

Office Action for Russian Application No. 2020500364, dated Aug. 25, 2020, 11 pages.

(56)

References Cited

OTHER PUBLICATIONS

Office Action For Russian Application No. 2020500365, dated Sep. 4, 2020, 4 pages.
 Office Action for Russian Application No. 2020500366, dated Sep. 11, 2020, 13 pages.
 Office Action dated Apr. 2, 2021 for Chinese Application No. 201680037678.4, 16 pages.
 Office Action dated Sep. 6, 2017 for Korean Application No. 10-2017-7017425, 9 pages.
 Office Action dated Sep. 6, 2017 for Korean Application No. 10-2017-7017430, 9 pages.
 Office Action dated Jan. 10, 2020 for Indian Application No. 201847042184, 5 pages.
 Office Action dated Mar. 10, 2020 for Japanese Application No. 2018-555932, 10 pages.
 Office Action dated Jun. 16, 2020 for Korean Application No. 10-2018-7032766, 10 pages.
 Office Action dated Jun. 16, 2020 for Korean Application No. 10-2018-7032781, 9 pages.
 Office Action dated Aug. 17, 2016 for Korean Application No. 10-2014-7032958, 13 pages.
 Office Action dated Aug. 17, 2020 for Chinese Application No. 201780028992.0, 13 pages.
 Office Action dated Jun. 17, 2020 for Korean Application No. 10-2018-7032794, 15 pages.
 Office Action dated Mar. 17, 2020 for Japanese Application No. JP2019-501592, 4 pages.
 Office Action dated Feb. 18, 2020 for Japanese Application No. 2018-559712, 6 pages.
 Office Action dated Jun. 18, 2020 for Russian Application No. 2019505810, 7 pages.
 Office Action dated Jul. 20, 2017 for Chilean Application No. 2014-002840, 7 pages.
 Office Action dated Apr. 24, 2019 for Chinese Application No. 201710413187.1, 16 pages.
 Office Action dated Feb. 25, 2020 for Japanese Application No. 2018-554526, 12 pages.
 Office Action dated Dec. 26, 2017 for Chinese Application No. 201480059966.0, 29 pages.
 Office Action dated Jul. 27, 2018 for Korean Application No. 10-2013-7033866, 22 pages.
 Office Action dated Jun. 27, 2017 for Japanese Application No. 2016-527295, 8 pages.
 Office Action dated Oct. 27, 2020 for Japanese Application No. 2018-555932, 6 pages.

Office Action dated Aug. 28, 2019 for Indian Application No. 201647014549, 6 pages.
 Office Action dated Jan. 28, 2020 for Japanese Application No. 2018-551932, 6 pages.
 Office Action dated Jul. 28, 2017 for Korean Application No. 10-2016-7010831, 11 pages.
 Office Action dated Jun. 28, 2019 for Russian Application No. 2018139838, 5 pages.
 Office Action dated Jun. 4, 2020 for Russian Application No. 2019504647, 11 pages.
 Office Action dated Jan. 6, 2020 for Chinese Application No. 201680037678.4, 10 pages.
 Office Action dated Feb. 25, 2020 for Japanese Application No. 2018-554501, 12 pages.
 Patio Kits Direct, "Insulated Roof Panels," DIY Alumawood Patio Cover Kits, dated Sep. 20, 2018, as available at <https://www.patiokitsdirect.com/about-insulation>, 2 pages.
 "QQQ Honor and Smart," By H KL Reviews, dated Mar. 15, 2019. Found online [Feb. 3, 2021], <https://www.youtube.com/watch?v=velv8NX6smE> (Year: 2019).
 Search Report dated Mar. 24, 2015 for Chinese Application No. 201280029767.6 filed Aug. 24, 2012, 6 pages.
 Search Report dated Dec. 25, 2019 for Chinese Application No. 201680037678.4, 2 pages.
 Second Office Action dated May 19, 2021 for Chinese Application No. 2017800293080, 18 pages.
 Second Office Action dated Jan. 16, 2017 for Chinese Application No. 201380048636.7, 24 pages.
 Second office Action dated Sep. 28, 2020 for Chinese Application No. 201680037678.4, 21 pages.
 Third Office Action dated Dec. 10, 2021 for Chinese Application No. 201780028361.9, 15 pages.
 Translation of Office Action dated Mar. 25, 2019 for Chinese Application No. 201610804046.8, 17 pages.
 Uranaka T., et al., "British American Tobacco to Test Tobacco E-cigarette in Japan," Nov. 8, 2016, Retrieved from <http://www.reuters.com/article/US-brit-am-tobacco-ecigarettes-idUSKBN1330AG> on Apr. 7, 2017, 4 pages.
 Warriar M., et al., "Effect of the Porous Structure of Graphite on Atomic Hydrogen Diffusion and Inventory," Nucl. Fusion, vol. 47, 2007, pp. 1656-1663.
 Written Opinion for Application No. PCT/EP2012/066485, dated Oct. 15, 2013, 6 pages.
 Written Opinion for Application No. PCT/EP2016/064756, dated Oct. 5, 2016, 4 pages.
 Written Opinion for Application No. PCT/EP2017/061526, dated Aug. 2, 2017, 8 pages.

* cited by examiner

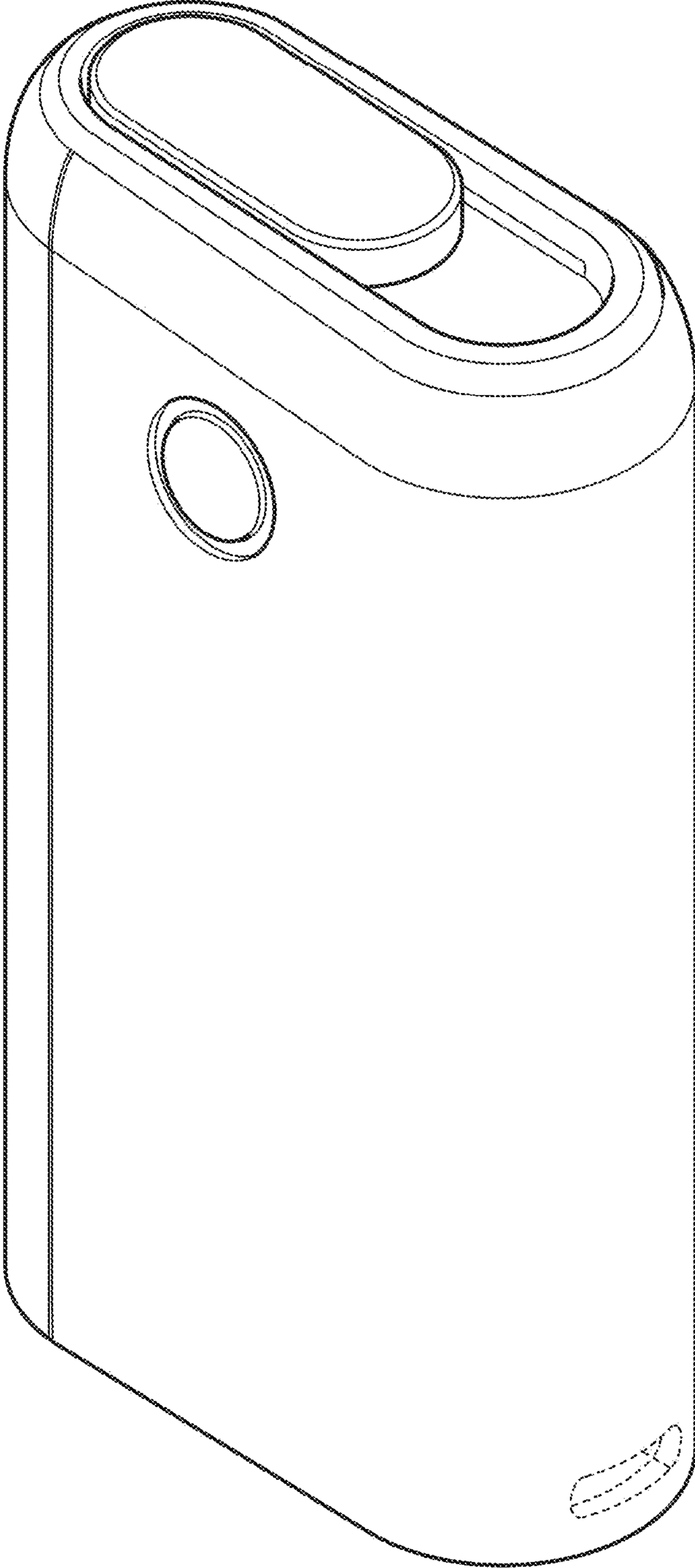

FIG. 1

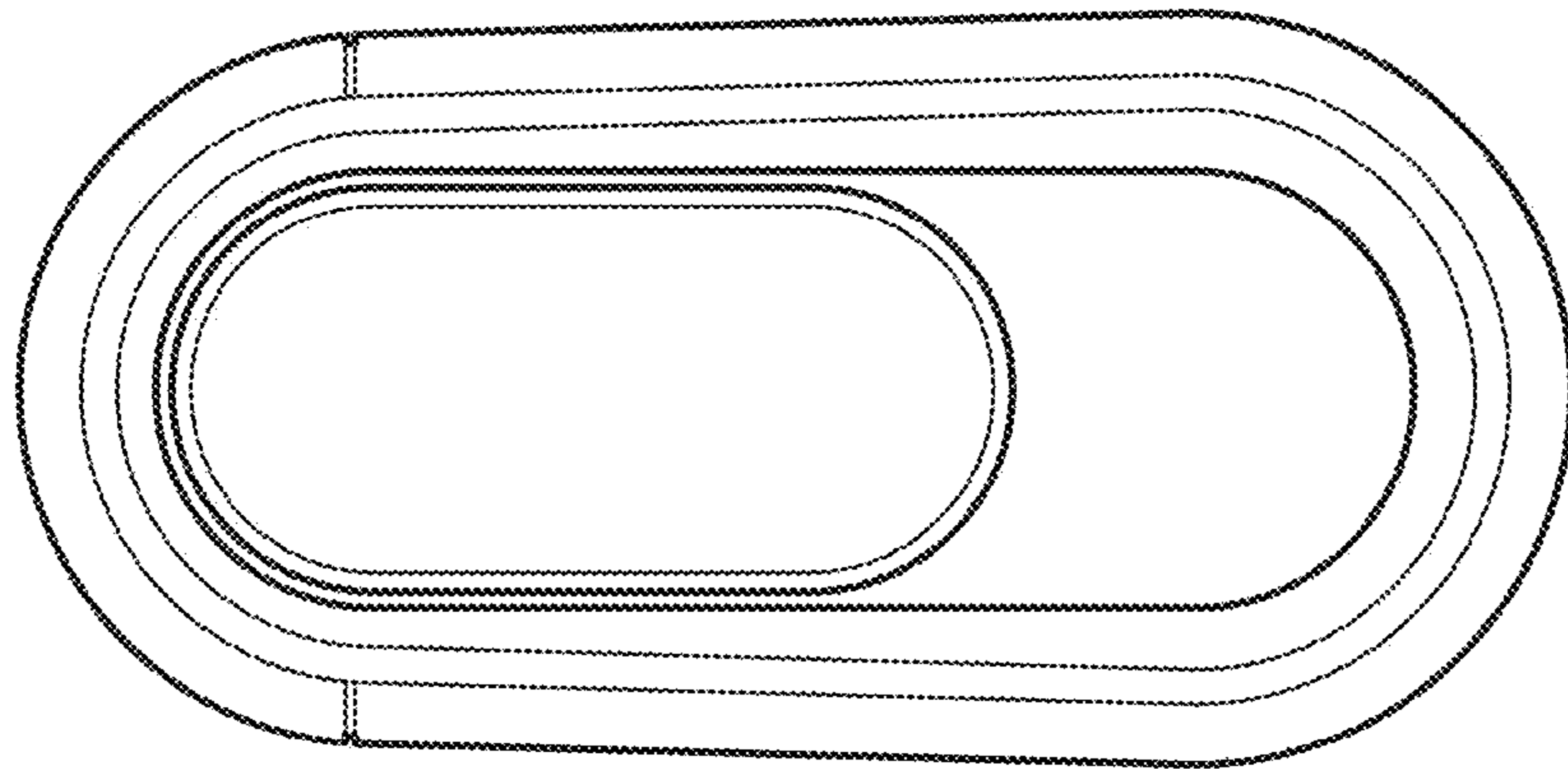

FIG. 2

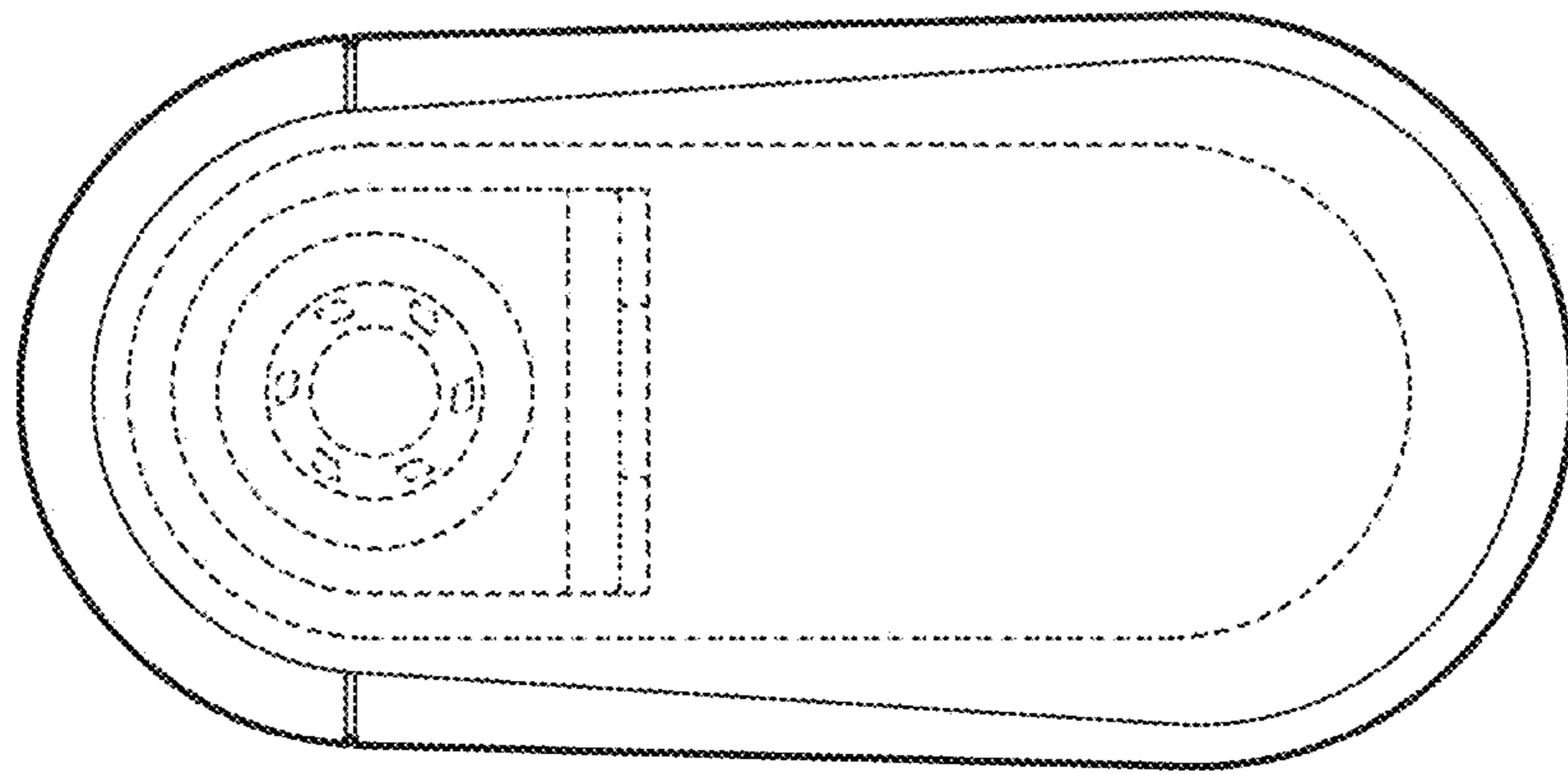

FIG. 3

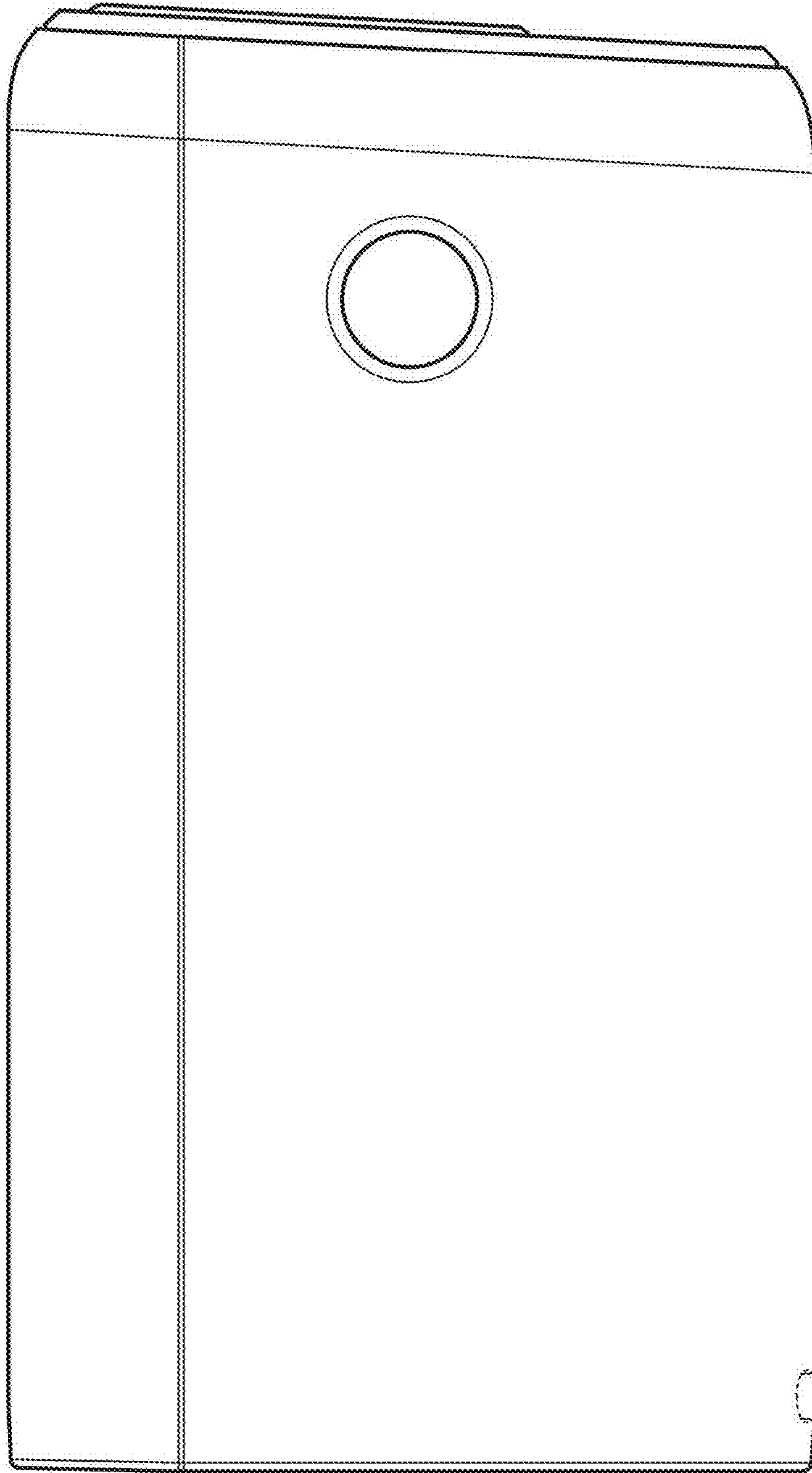

FIG. 4

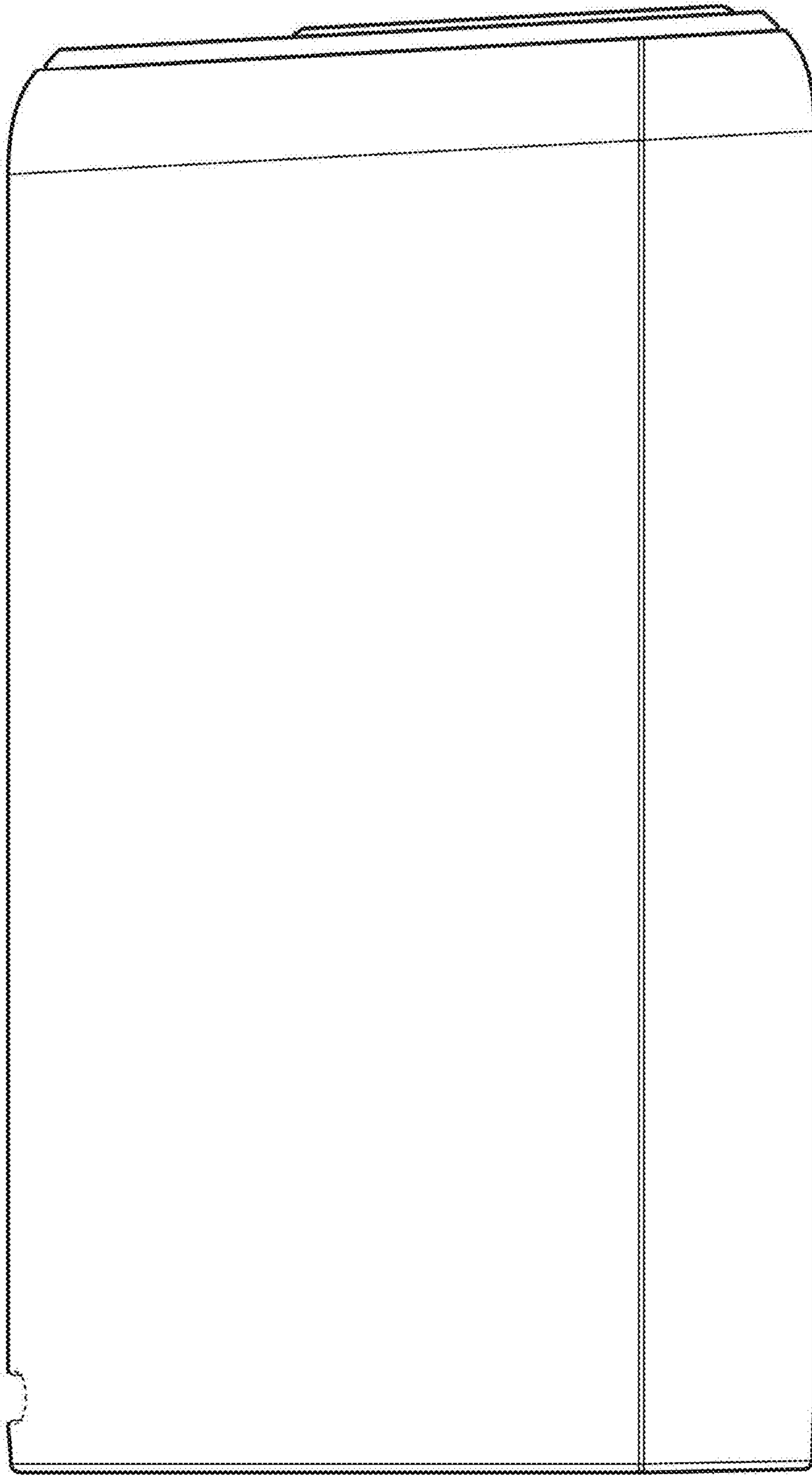

FIG. 5



FIG. 6

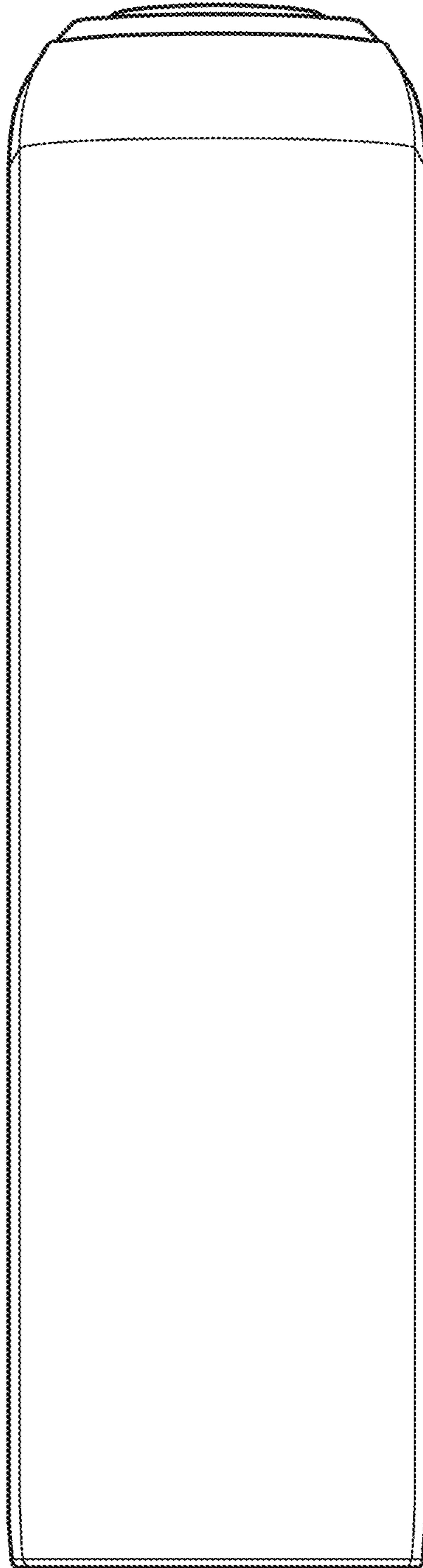

FIG. 7

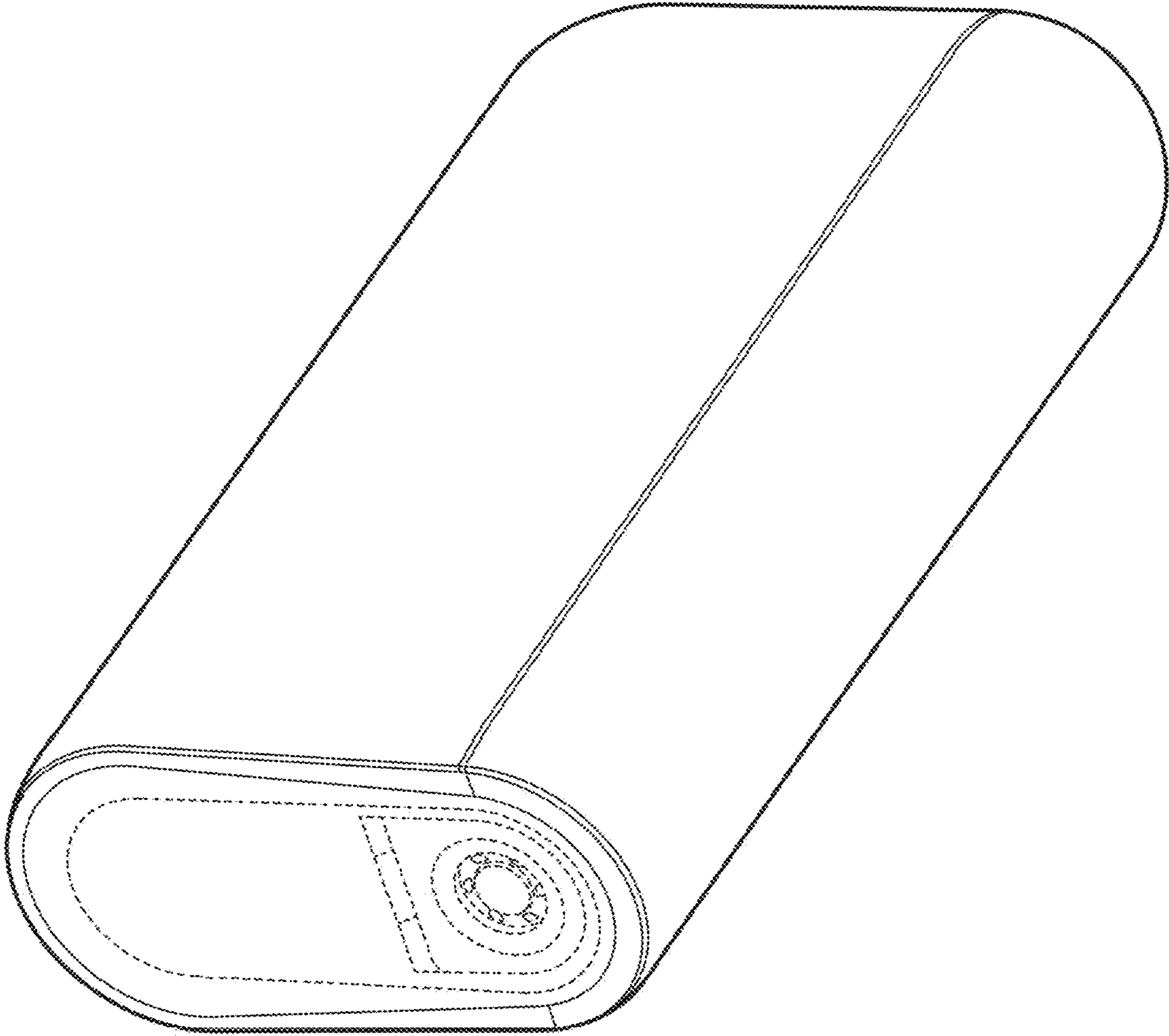

FIG. 8