



(56)

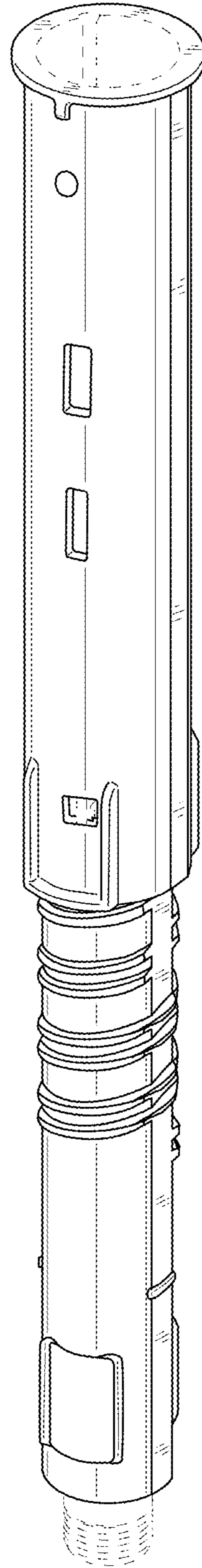
References Cited

U.S. PATENT DOCUMENTS

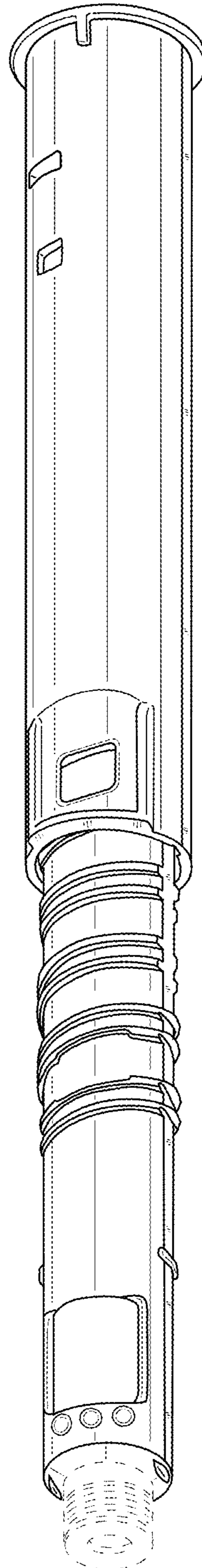
8,298,175 B2 10/2012 Hirschel et al.  
 8,343,103 B2 1/2013 Moser  
 D676,957 S \* 2/2013 Schneider ..... D24/113  
 8,439,864 B2 5/2013 Galbraith et al.  
 8,562,570 B2 10/2013 Hirschel et al.  
 8,679,071 B2 3/2014 Hirschel et al.  
 8,734,403 B2 5/2014 Hirschel et al.  
 8,758,292 B2 6/2014 Tschirren et al.  
 8,827,963 B2 9/2014 Hirschel et al.  
 D721,802 S \* 1/2015 Ohashi ..... D24/113  
 D729,930 S \* 5/2015 Geert-Jensen ..... D24/112  
 D734,450 S \* 7/2015 Geert-Jensen ..... D24/113  
 9,199,039 B2 12/2015 Moser et al.  
 D752,210 S \* 3/2016 Amend Kwasnik ..... D24/113  
 9,278,178 B2 3/2016 Hirschel et al.  
 9,320,853 B2 4/2016 Gallbraith et al.  
 D758,571 S \* 6/2016 Geert-Jensen ..... D24/113  
 D765,240 S \* 8/2016 Hauck ..... D24/113  
 D765,833 S \* 9/2016 Geert-Jensen ..... D24/112  
 D766,425 S \* 9/2016 Hauck ..... D24/113  
 D777,907 S \* 1/2017 Amend Kwasnik ..... D24/113  
 D785,784 S \* 5/2017 Jones ..... D24/113  
 9,889,258 B2 \* 2/2018 Bengtsson ..... A61M 5/2466  
 D819,199 S \* 5/2018 Amend Kwasnik ..... D24/113  
 D863,547 S \* 10/2019 Fritz ..... D24/112  
 D878,561 S \* 3/2020 Draper ..... D24/113

11,364,348 B2 \* 6/2022 Keitel ..... A61M 5/31585  
 2009/0308386 A1 \* 12/2009 Kronstedt ..... A61M 5/20  
 604/311  
 2011/0034902 A1 \* 2/2011 Markussen ..... A61M 5/3157  
 604/211  
 2011/0098658 A1 \* 4/2011 Enggaard ..... A61M 5/3155  
 604/207  
 2012/0253274 A1 \* 10/2012 Karlsson ..... A61M 5/2448  
 604/89  
 2014/0155820 A1 \* 6/2014 Holmqvist ..... A61M 5/31571  
 604/228  
 2014/0163474 A1 \* 6/2014 Draper ..... A61M 5/24  
 604/218  
 2014/0194830 A1 \* 7/2014 Nzike ..... A61M 5/31536  
 604/211  
 2014/0358093 A1 \* 12/2014 Soerensen ..... A61M 5/28  
 604/232  
 2015/0174328 A1 \* 6/2015 Loof ..... A61M 5/24  
 604/187  
 2015/0209518 A1 \* 7/2015 Moser ..... A61M 5/2425  
 222/309  
 2016/0213850 A1 \* 7/2016 Lööf ..... A61M 5/28  
 2016/0287808 A1 \* 10/2016 Madsen ..... A61M 5/31568  
 2018/0161503 A1 \* 6/2018 Windum ..... A61M 5/24  
 2019/0167903 A1 \* 6/2019 Staub ..... A61M 5/2033  
 2021/0077737 A1 \* 3/2021 Holmqvist ..... A61M 5/19  
 2021/0128841 A1 \* 5/2021 Andersen ..... A61M 5/20  
 2022/0184319 A1 \* 6/2022 Ploch ..... A61M 5/31533

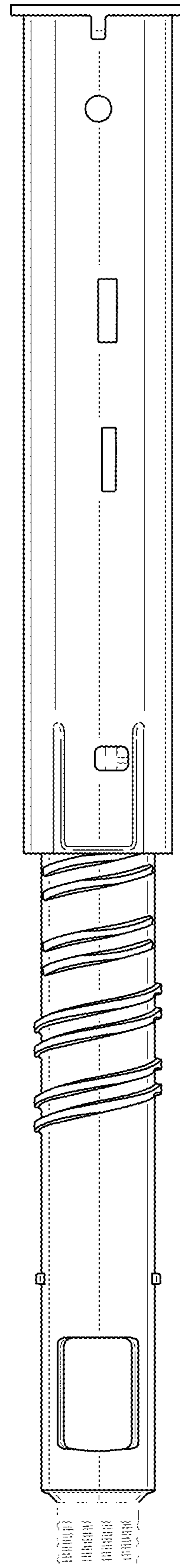
\* cited by examiner



**FIG. 1**

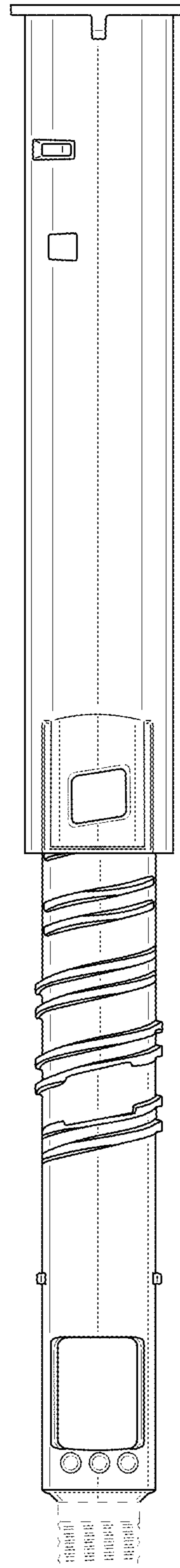


**FIG. 2**

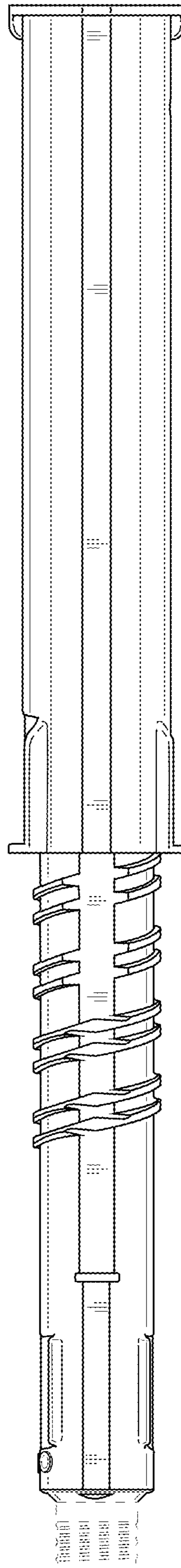


**FIG. 3**

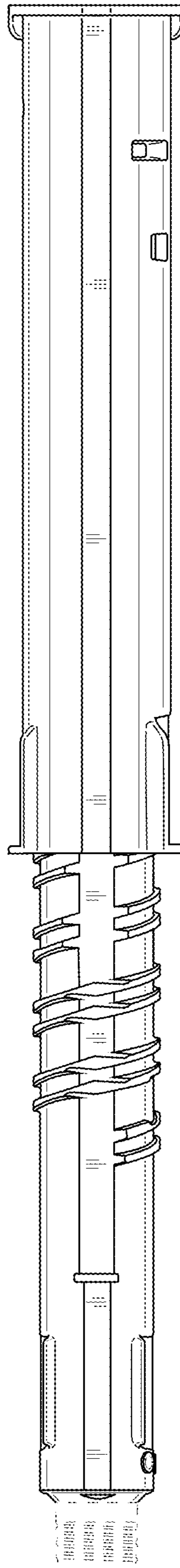




**FIG. 4**

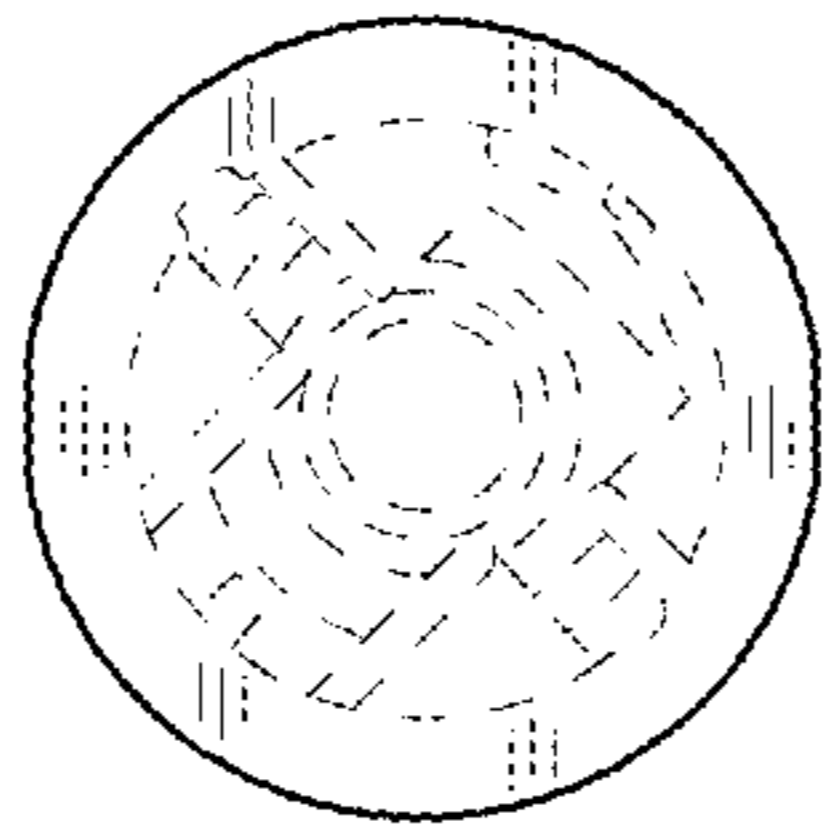


**FIG. 5**

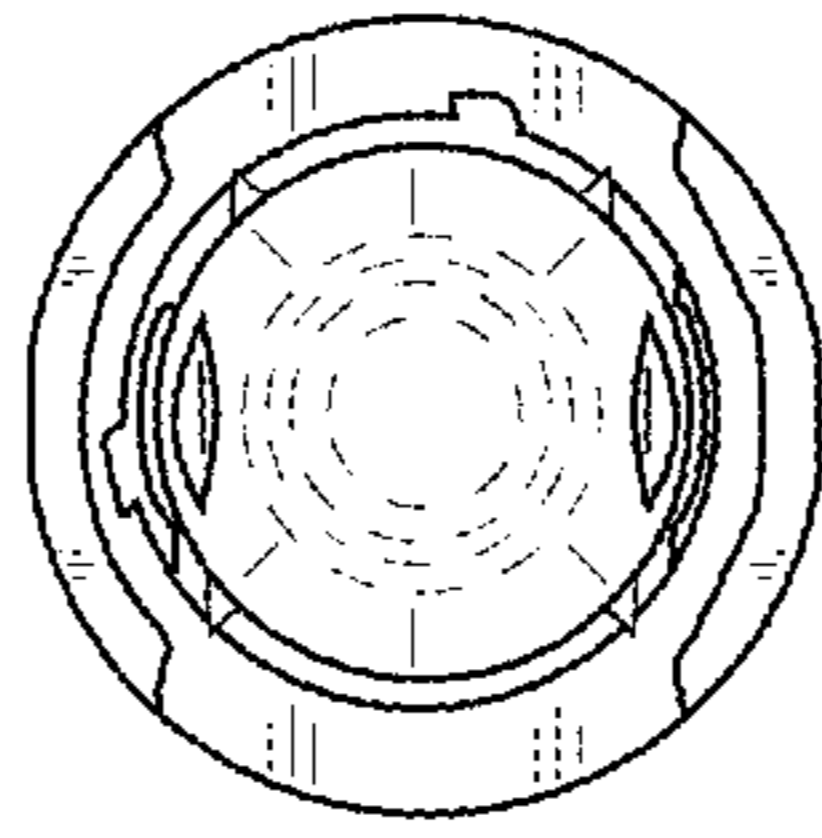


**FIG. 6**

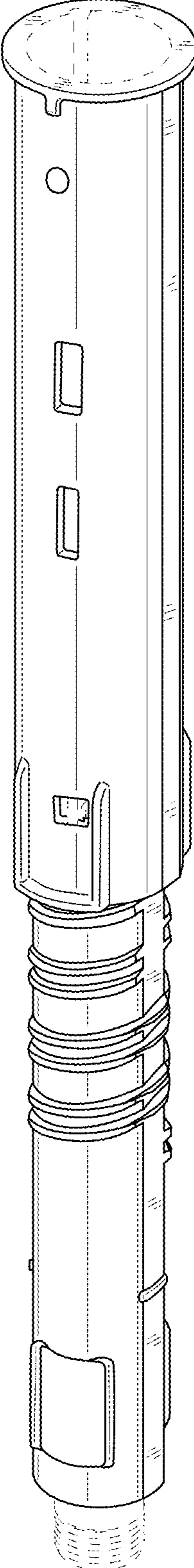




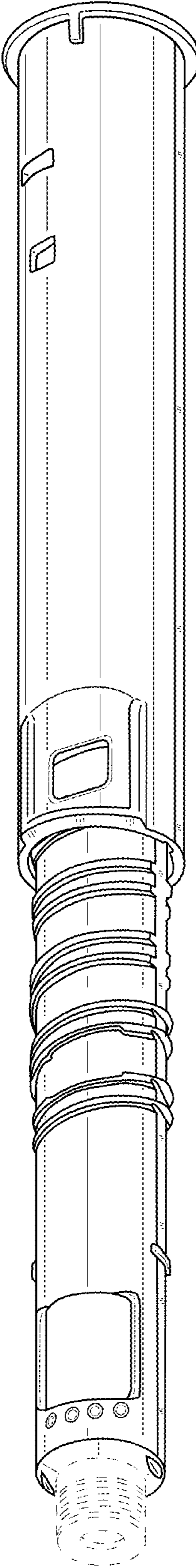
***FIG. 7***



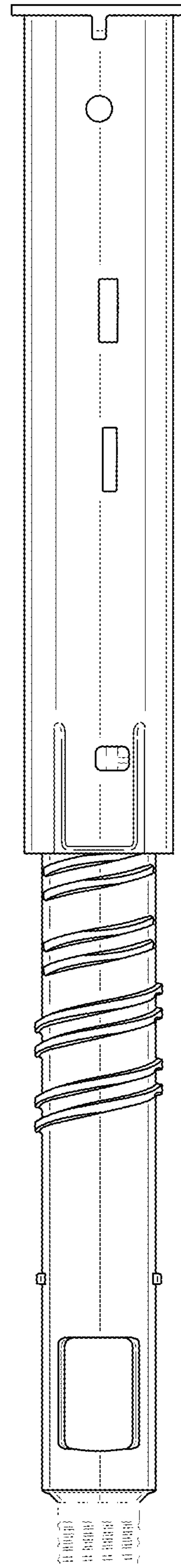
**FIG. 8**



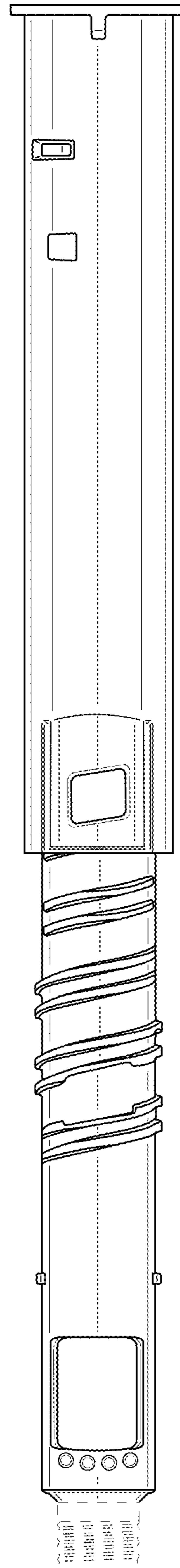
**FIG. 9**



**FIG. 10**

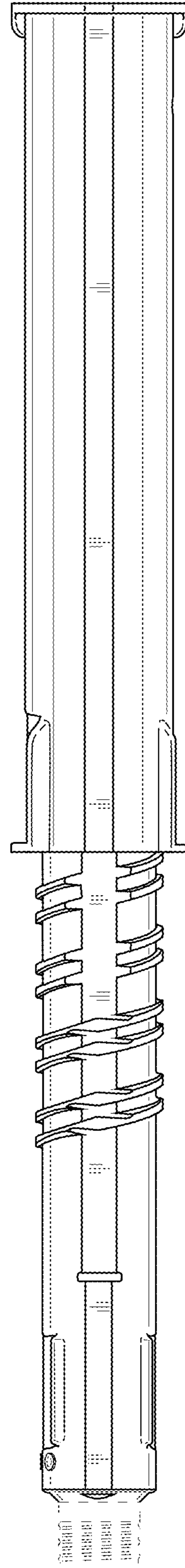


**FIG. 11**

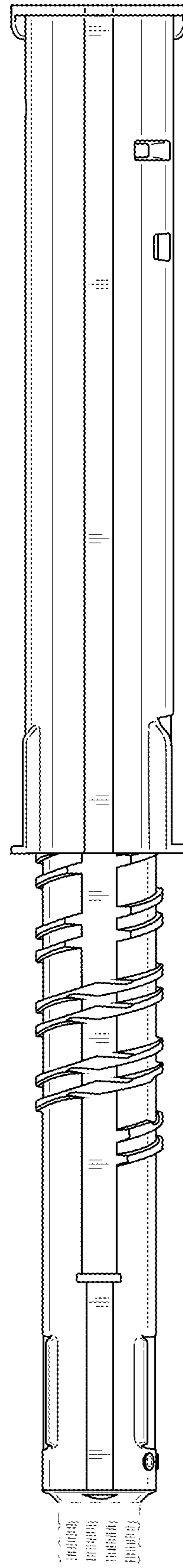


**FIG. 12**

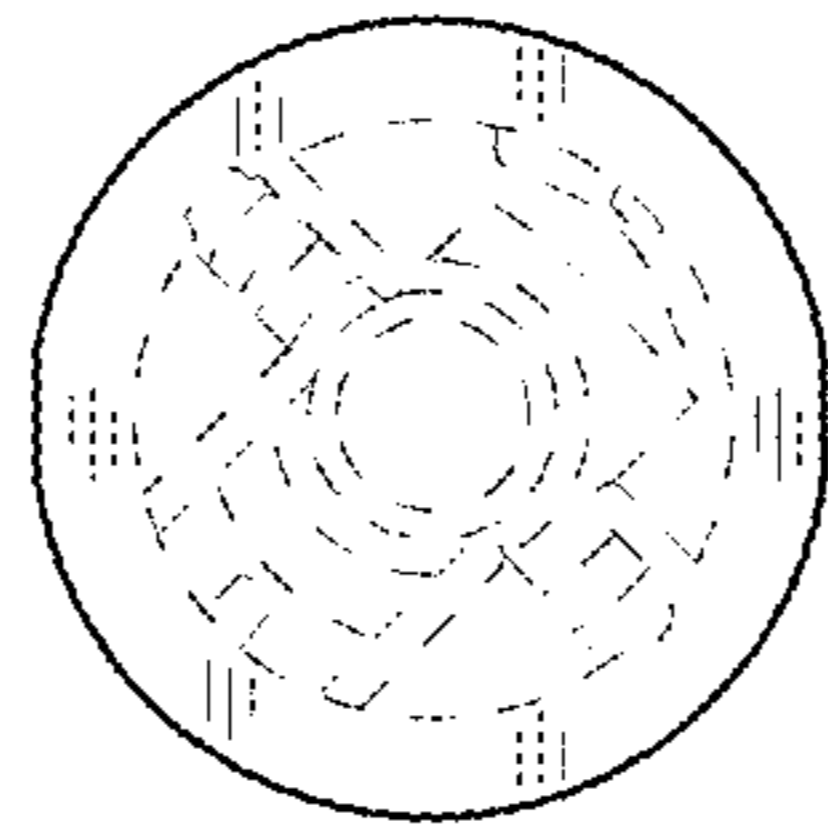




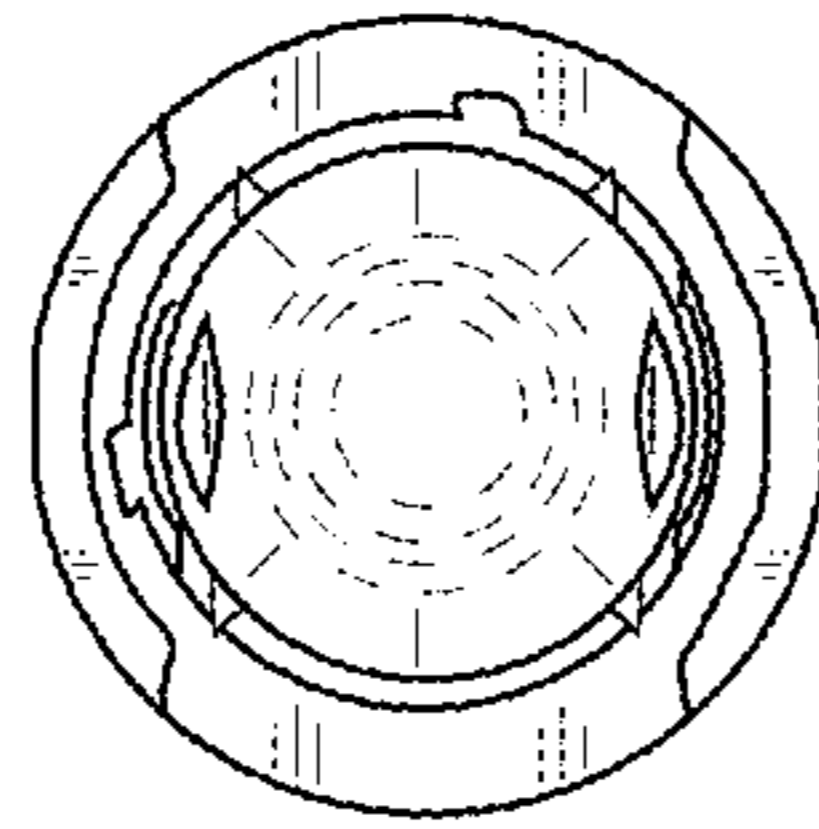
**FIG. 13**



**FIG. 14**



***FIG. 15***



**FIG. 16**