



US00D988380S

(12) **United States Design Patent**
Qin

(10) **Patent No.:** **US D988,380 S**
(45) **Date of Patent:** **** Jun. 6, 2023**

- (54) **TUMBLER PRESS MACHINE**
- (71) Applicant: **Shenzhen Yannuo Technology Co., Ltd.**, Shenzhen (CN)
- (72) Inventor: **Shixi Qin**, Shenzhen (CN)
- (73) Assignee: **Shenzhen Yannuo Technology Co., Ltd.**, Shenzhen (CN)
- (**) Term: **15 Years**
- (21) Appl. No.: **29/862,153**
- (22) Filed: **Dec. 7, 2022**
- (51) **LOC (14) Cl.** **15-10**
- (52) **U.S. Cl.**
USPC **D15/146**; D15/122; D15/144
- (58) **Field of Classification Search**
USPC D7/336, 337, 352, 356, 362, 602;
D15/122, 123, 144, 146; D18/50, 53
CPC .. B41F 16/00; B41F 16/0026; B41F 16/0093;
B41F 1/38; B30B 15/047; B30B 15/061;
B30B 15/064; B30B 15/34; B41M 1/34;
B41M 1/40; B41M 5/03; B41M 5/035;
B44C 1/1712; B44C 1/1716
See application file for complete search history.

D894,245 S 8/2020 Li et al.
D935,501 S * 11/2021 Li D15/146
D947,262 S * 3/2022 Chen D15/144.1
D955,080 S * 6/2022 Guo D32/70
2004/0244617 A1* 12/2004 Eppinger B41F 15/12
101/287
2014/0295100 A1* 10/2014 Baskerville B05D 3/0281
118/620

OTHER PUBLICATIONS

Tiqtak, Tumbler Heat Press Machine, (first available Mar. 3, 2022), Amazon.com, URL:<<https://www.amazon.com/dp/B09TT7NMCS>> (Year: 2022).*

Realkant, Tumbler Heat Press Machine, (first available Mar. 28, 2022), Amazon.com, URL:<<https://www.amazon.com/dp/B09V1C1NQC>> (Year: 2022).*

(Continued)

Primary Examiner — Calvin E Vansant
Assistant Examiner — Mark T. Philipps

(57) **CLAIM**

The ornamental design for a tumbler press machine, as shown and described.

DESCRIPTION

FIG. 1 is a front, top and right side perspective view of a tumbler press machine, showing my new design;
FIG. 2 is a front view thereof;
FIG. 3 is a rear view thereof;
FIG. 4 is a left side view thereof;
FIG. 5 is a right side view thereof;
FIG. 6 is a top view thereof; and,
FIG. 7 is a bottom view thereof.
The broken lines in the drawings illustrate the portions of the tumbler press machine, which form no part of the claimed design.

1 Claim, 7 Drawing Sheets

(56) **References Cited**
U.S. PATENT DOCUMENTS

D250,896 S *	1/1979	Huber	600/490
4,595,607 A *	6/1986	Betteridge	B29C 63/0069 427/195
D298,167 S *	10/1988	Schaffer	D24/165
D328,130 S *	7/1992	Claxton, III	D24/165
D341,658 S *	11/1993	Kojima	D24/165
D353,604 S *	12/1994	Prokop	D15/146
D557,717 S *	12/2007	Chen	D15/144
D616,098 S *	5/2010	Shibata	D24/165
D868,125 S *	11/2019	Shu	D15/144

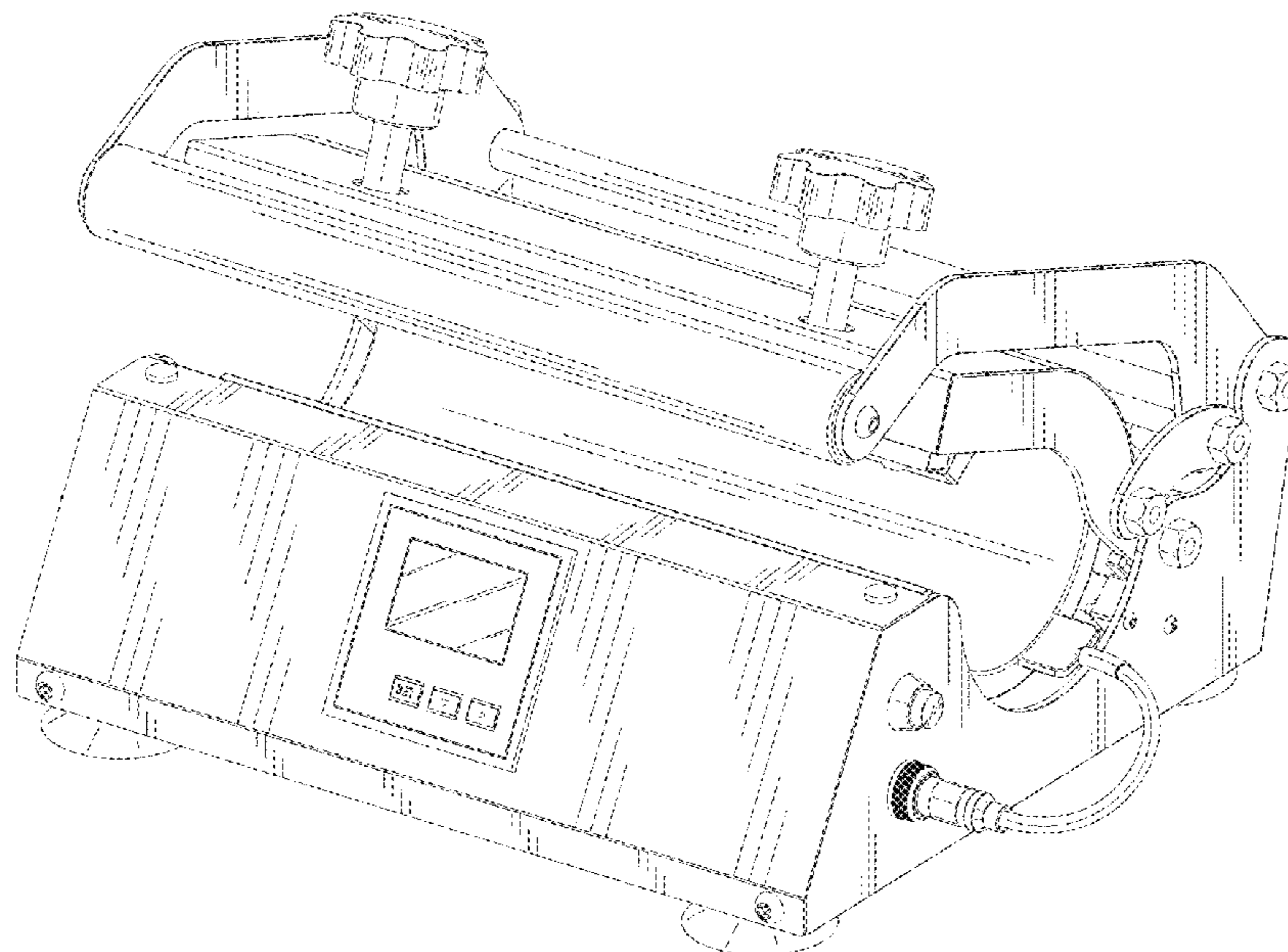

(56)

References Cited

OTHER PUBLICATIONS

PYD Life, 110V Tumbler Heat Press Machine, (first available Nov. 2, 2020), Amazon.com, URL:<<https://www.amazon.com/dp/B09CM73DXR>> (Year: 2020).*

Findcolor, 30oz Tumbler Heat Press Machine, (first available Dec. 21, 2021), Amazon.com, URL:<<https://www.amazon.com/dp/B09NX989KK>> (Year: 2021).*

* cited by examiner

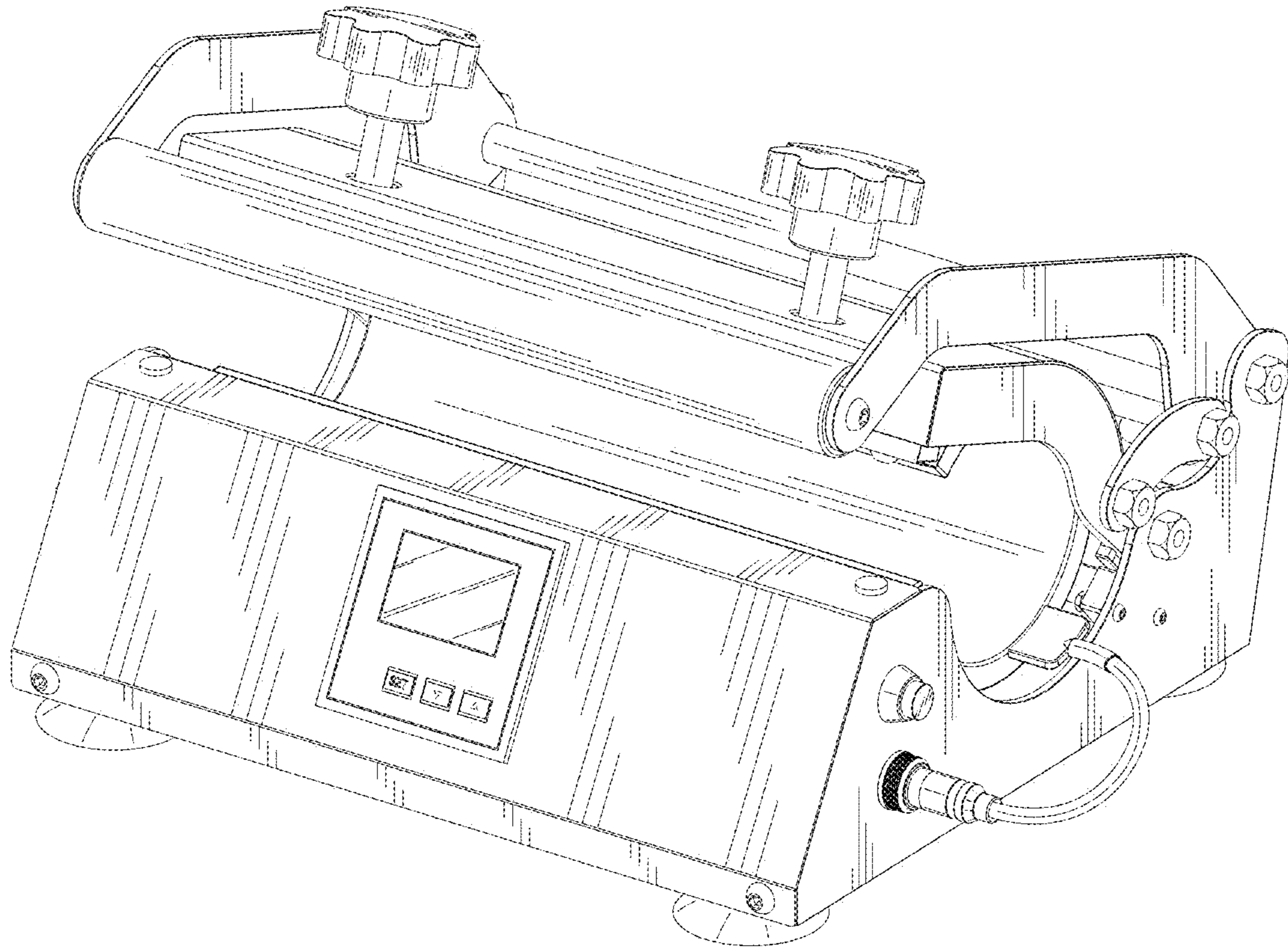

FIG. 1

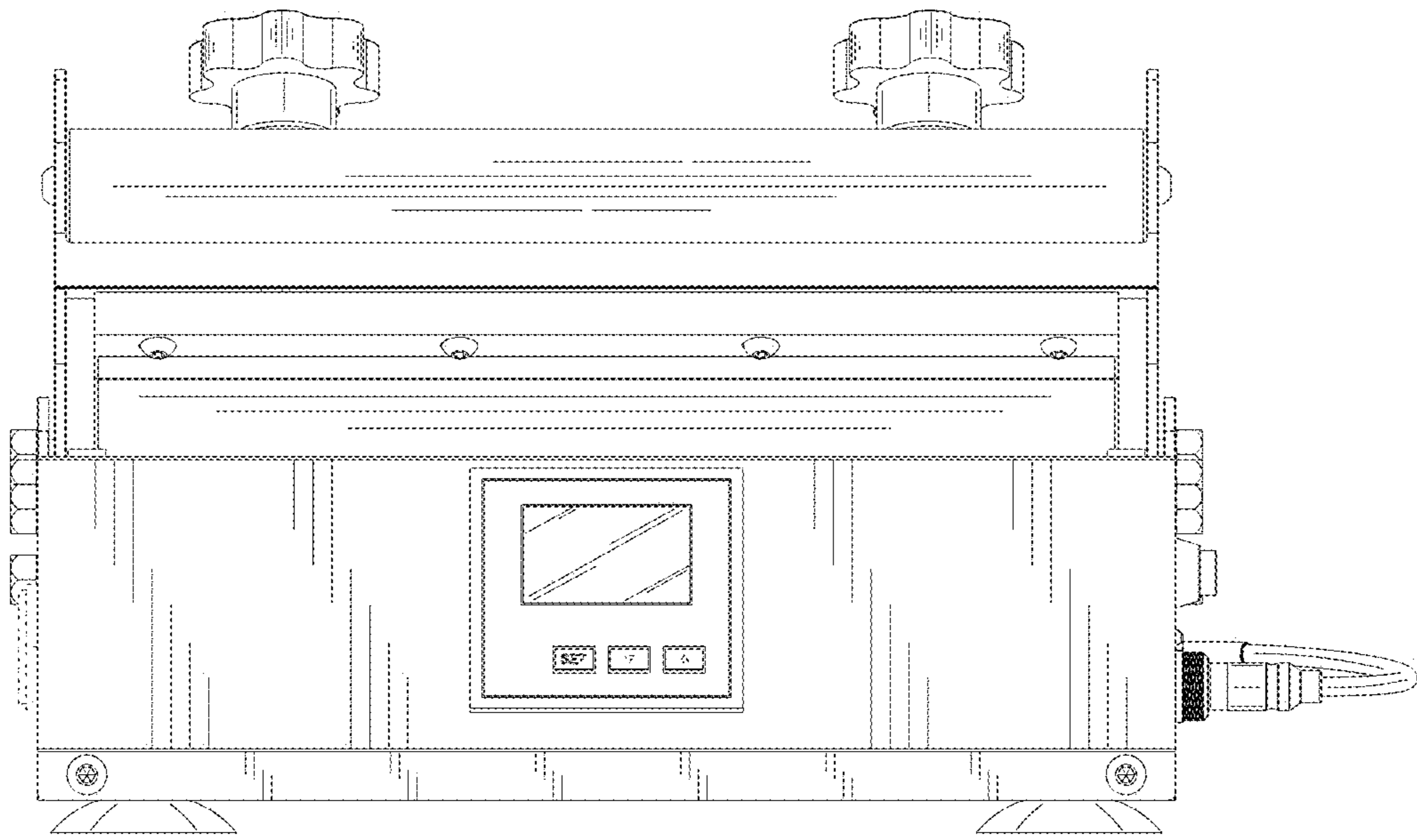

FIG. 2

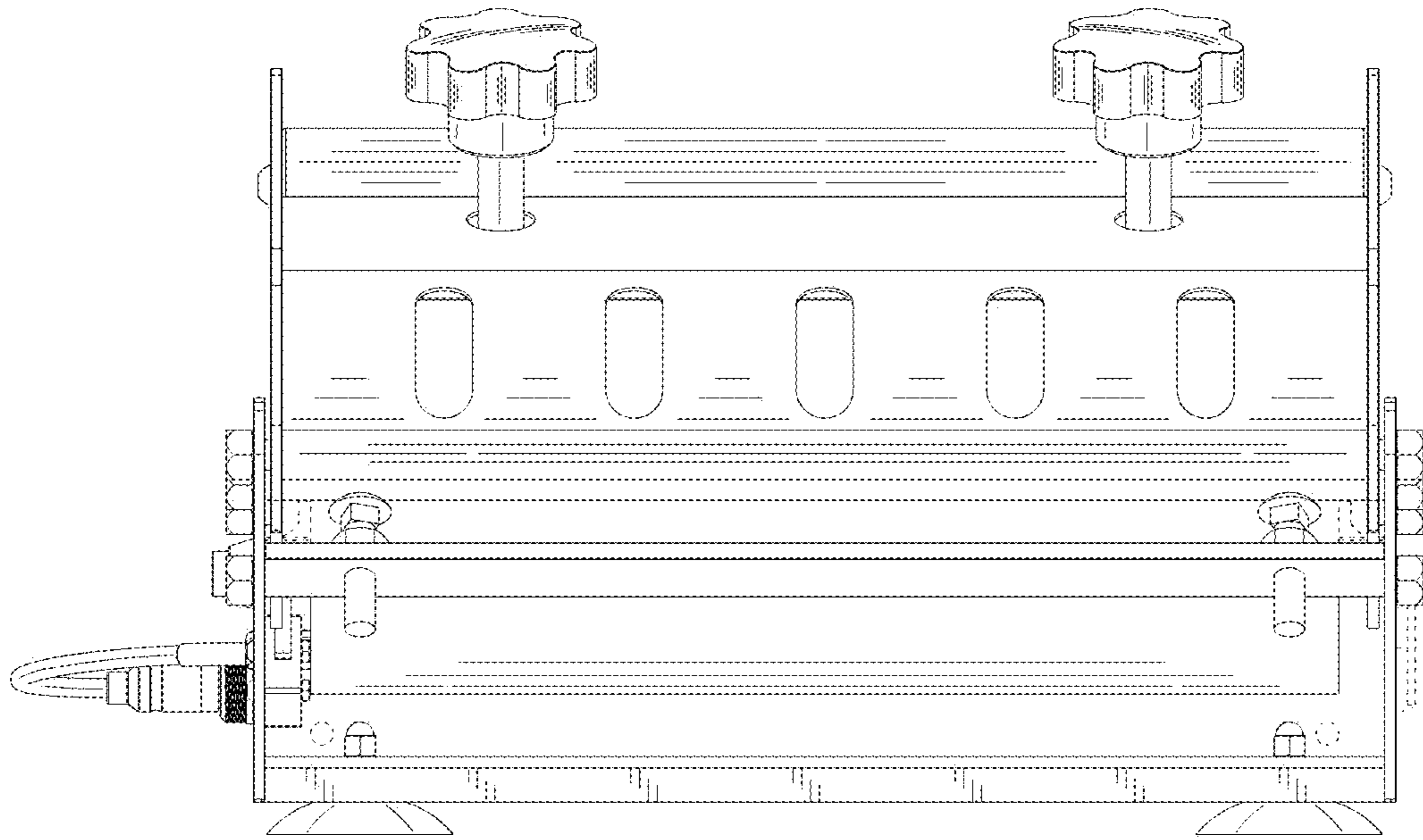

FIG. 3

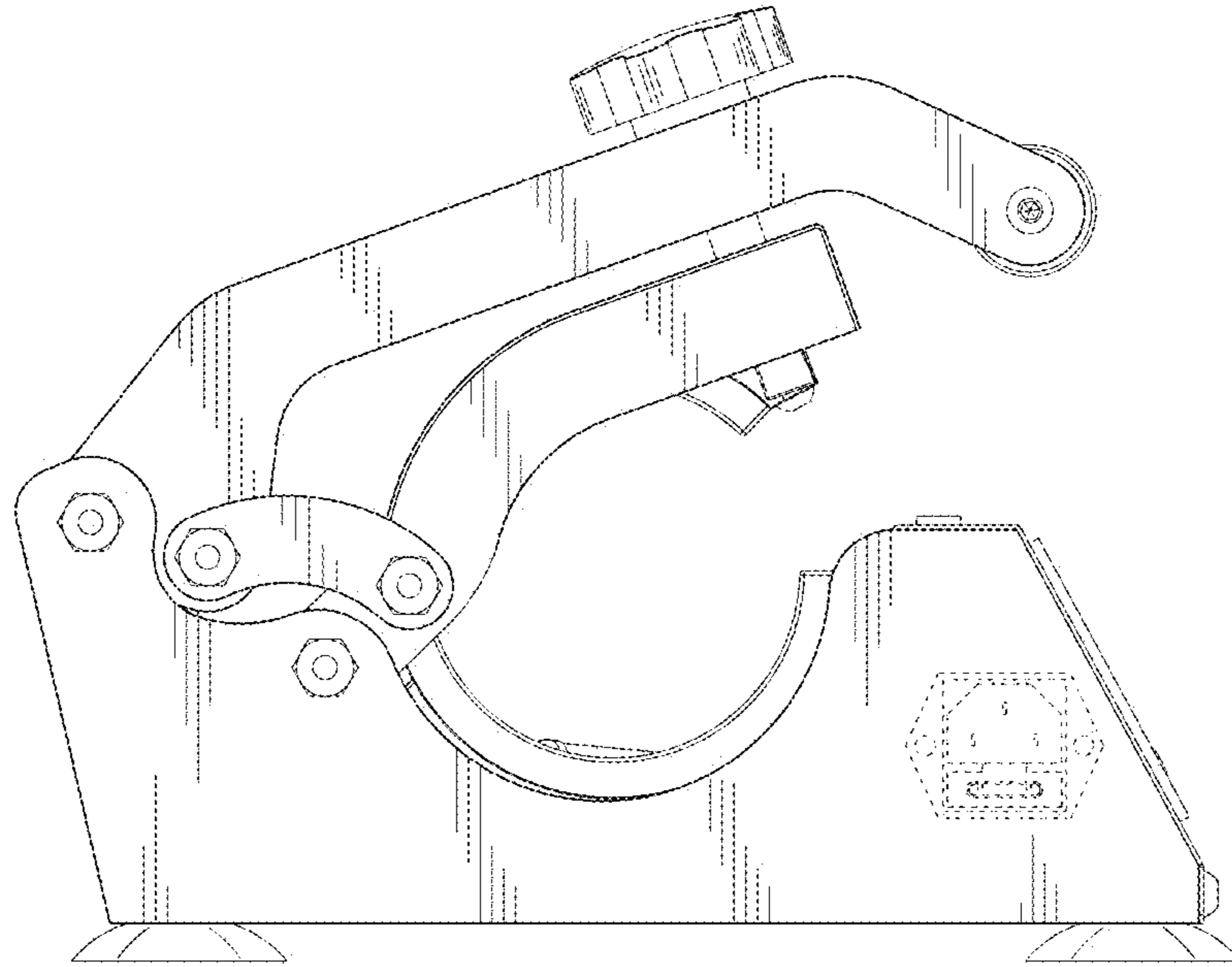

FIG. 4

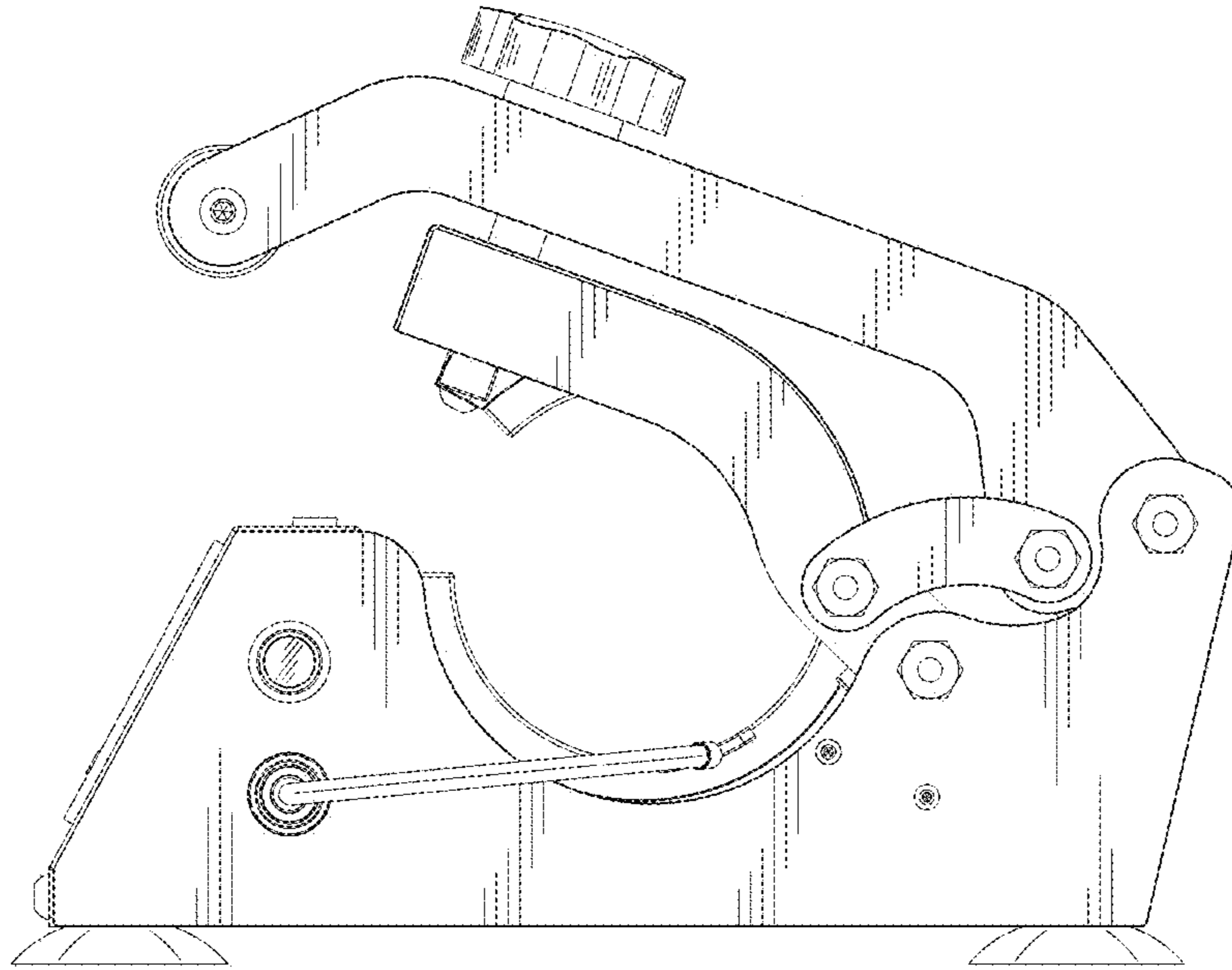

FIG. 5

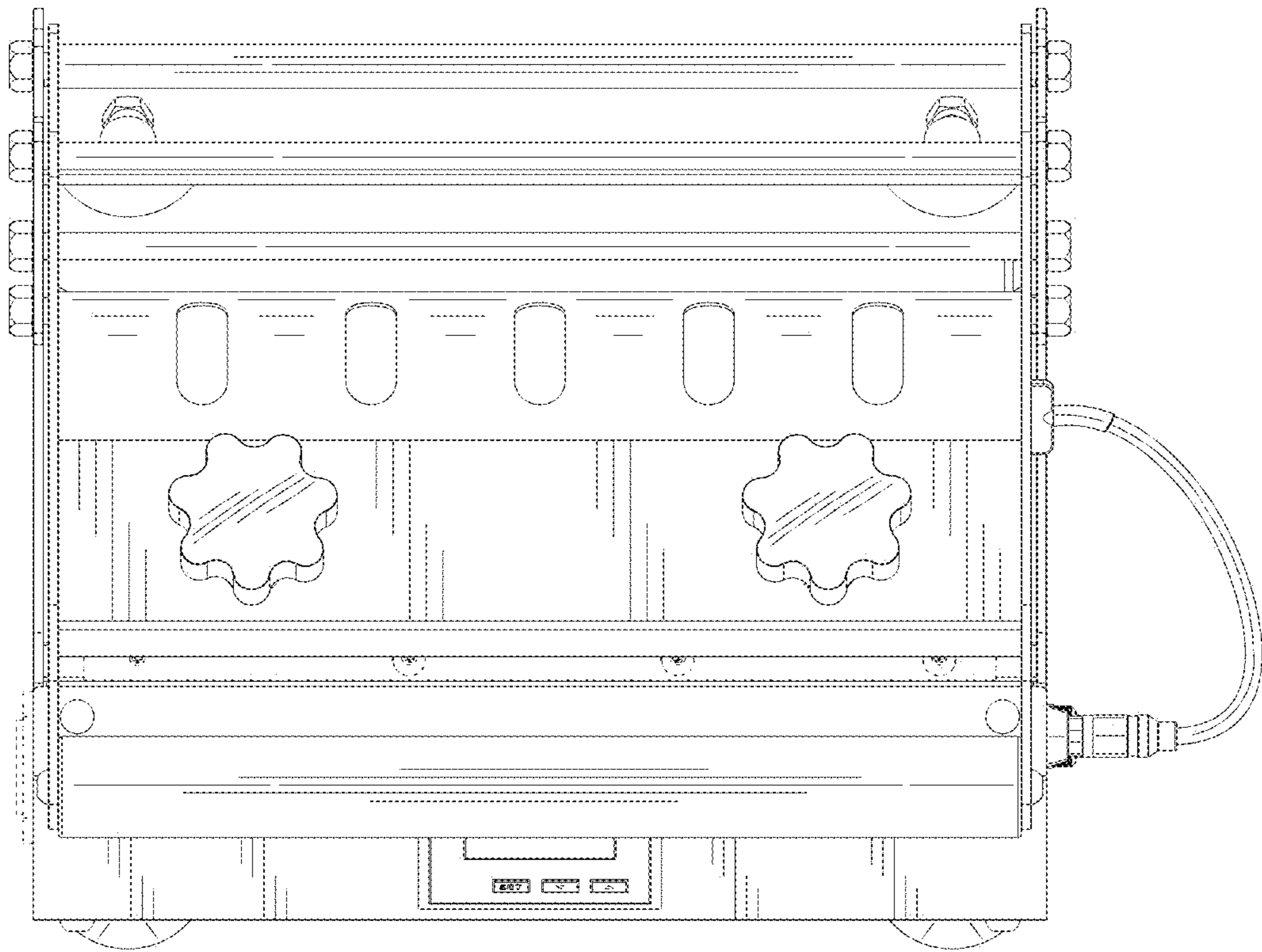

FIG. 6

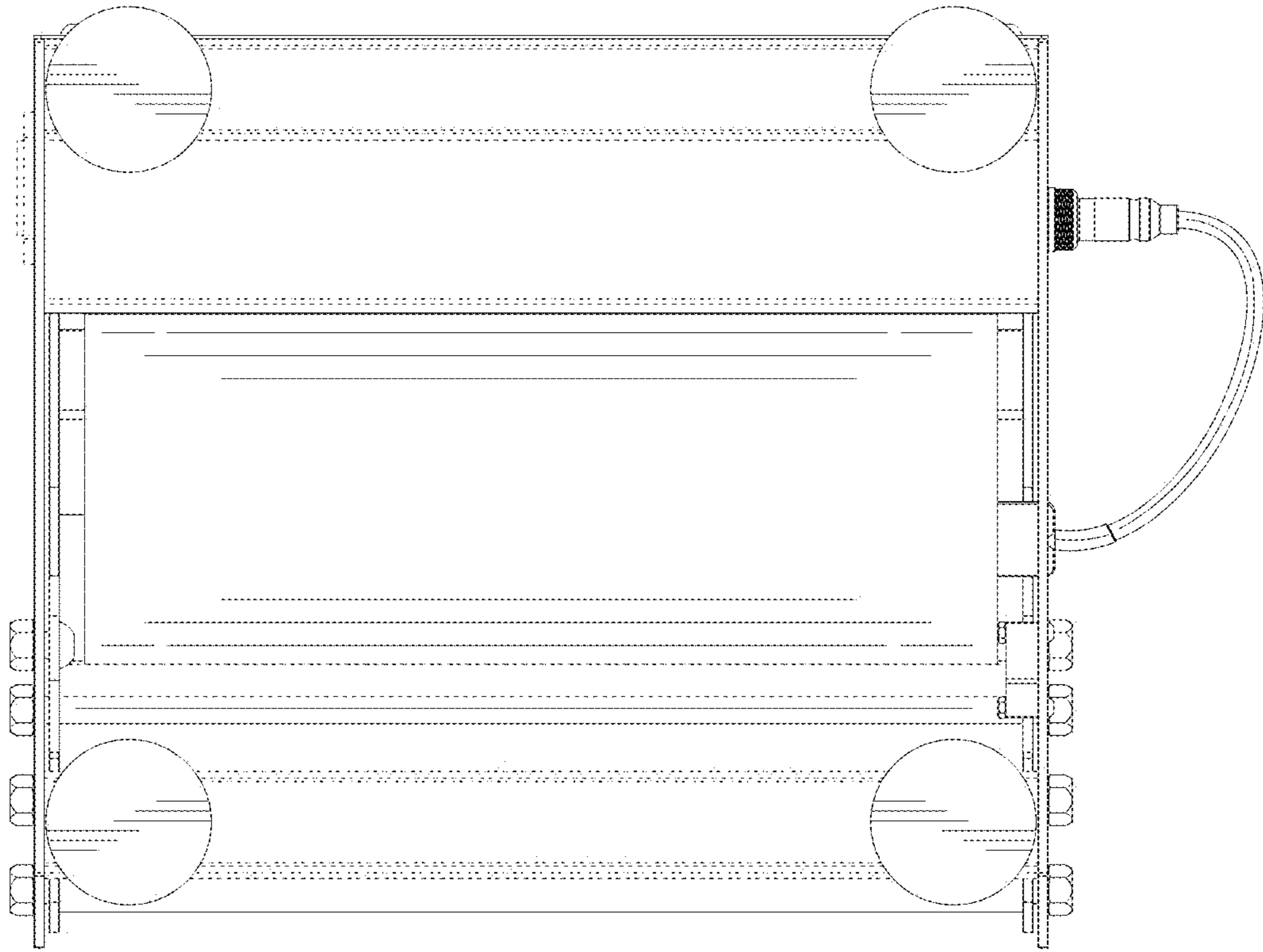

FIG. 7