



US00D987691S

(12) **United States Design Patent** (10) **Patent No.:** **US D987,691 S**
Xu et al. (45) **Date of Patent:** **** May 30, 2023**

(54) **MOWER BLADE ASSEMBLY**

34/73; A01D 34/006; A01D 34/64; A01D 34/82; A01D 34/001; A01D 34/008; A01D 34/828; A01D 34/74; A01D 34/78; A01D 34/824; A01D

(71) Applicant: **Nanjing Chervon Industry Co., Ltd.**, Nanjing (CN)

(Continued)

(72) Inventors: **Haishen Xu**, Nanjing (CN); **Toshinari Yamaoka**, Nanjing (CN); **Jian Yang**, Nanjing (CN)

(56) **References Cited**

(73) Assignee: **Nanjing Chervon Industry Co., Ltd.**, Nanjing (CN)

U.S. PATENT DOCUMENTS

(**) Term: **15 Years**

2,517,405 A 8/1950 Moss
2,697,323 A 12/1954 Horn

(Continued)

(21) Appl. No.: **29/865,319**

FOREIGN PATENT DOCUMENTS

(22) Filed: **Jul. 19, 2022**

AU 2004205280 A1 9/2004
CN 1409943 4/2003

(Continued)

Related U.S. Application Data

(63) Continuation of application No. 17/825,815, filed on May 26, 2022, which is a continuation of application (Continued)

OTHER PUBLICATIONS

ISA/CN, Int. Search Report issued on PCT application No. PCT/CN2019/107650, dated Dec. 24, 2019, 3 pgs.

(Continued)

(30) **Foreign Application Priority Data**

Sep. 27, 2018 (CN) 201821584956.0
Nov. 15, 2018 (CN) 201821889111.2
Apr. 18, 2019 (CN) 201910312144.3
Apr. 18, 2019 (CN) 201920533524.5
Jun. 28, 2019 (CN) 201910576318.7
Sep. 17, 2019 (CN) 201921545742.7

Primary Examiner — Mark A Goodwin

(74) *Attorney, Agent, or Firm* — Greenberg Traurig, LLP

(57) **CLAIM**

The ornamental design for a mower blade assembly, as shown and described.

(51) **LOC (14) Cl.** **15-03**

(52) **U.S. Cl.**
USPC **D15/17**

(58) **Field of Classification Search**
USPC D15/14, 17, 28; D8/4-12, 16, 20
CPC A01D 34/67; A01D 34/69; A01D 34/4116; A01D 34/4168; A01D 34/47; A01D 34/53; A01D 34/005; A01D 34/03; A01D 34/412; A01D 34/416; A01D 34/4165; A01D 34/00; A01D 34/43; A01D 34/63; A01D 34/661; A01D 34/664; A01D

DESCRIPTION

FIG. 1 is a top plan view of a mower blade assembly showing our new design;
FIG. 2 is a bottom plan view thereof;
FIG. 3 is a front side elevational view thereof; and,
FIG. 4 is a side elevational view thereof.
The broken lines depict portions of the mower blade assembly that form no part of the claimed design.

1 Claim, 3 Drawing Sheets

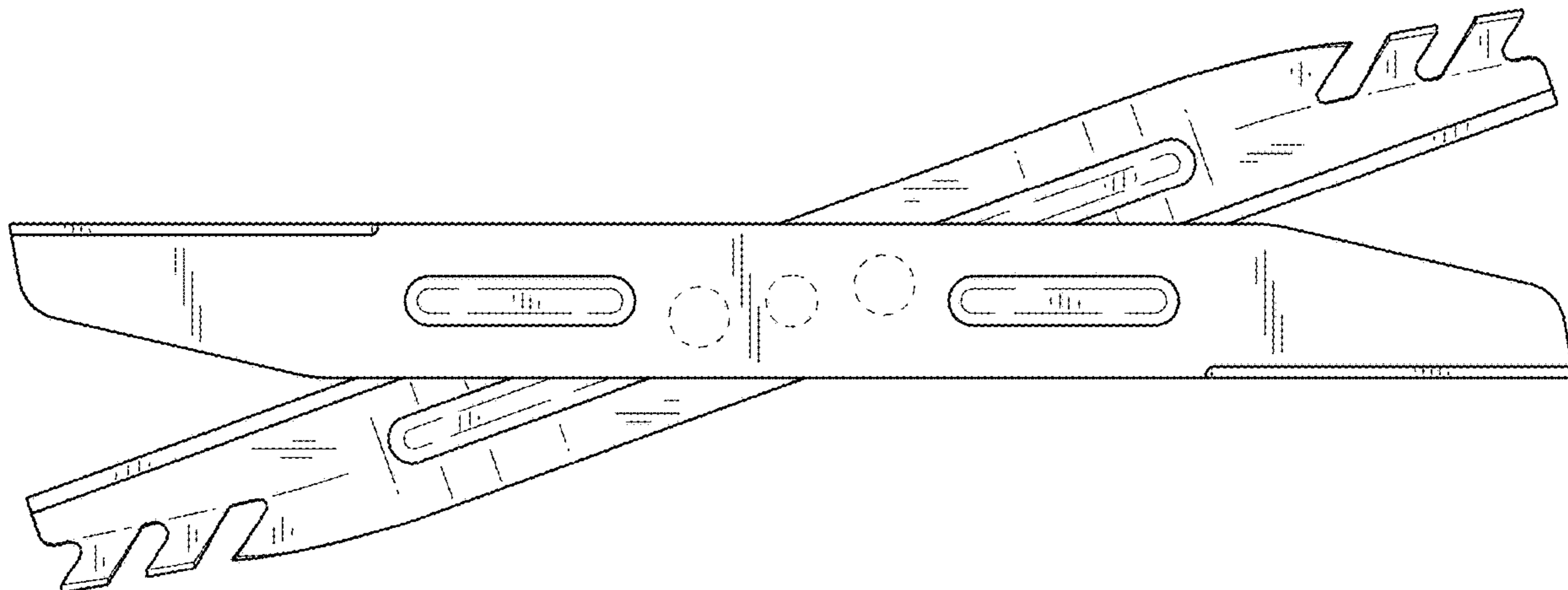

Related U.S. Application Data

No. 17/573,153, filed on Jan. 11, 2022, which is a continuation of application No. 17/236,239, filed on Apr. 21, 2021, now Pat. No. 11,246,260, which is a continuation of application No. 17/164,479, filed on Feb. 1, 2021, now Pat. No. 11,122,737, which is a continuation of application No. PCT/CN2019/107650, filed on Sep. 25, 2019.

(58) **Field of Classification Search**

CPC .. 34/6806; A01D 34/685; A01D 34/71; A01D 34/733; A01D 34/76; A01D 2101/00; A01D 43/063; A01D 43/077; A01D 43/14; A01D 42/005; A01D 42/04; Y10S 56/17; Y10S 56/20

See application file for complete search history.

(56) **References Cited**

U.S. PATENT DOCUMENTS

2,760,327 A 8/1956 Bovee
 3,044,241 A 7/1962 Snider
 3,162,990 A * 12/1964 Cook A01D 34/73
 D15/17
 3,192,692 A 7/1965 Arthur
 3,485,022 A * 12/1969 Freedlander A01D 34/73
 56/295
 3,564,824 A 2/1971 Tygh
 3,593,505 A 7/1971 Mittelstadt
 3,601,960 A 8/1971 Buechler
 3,823,367 A 7/1974 Kaye et al.
 3,910,017 A 10/1975 Thorud
 4,037,695 A 7/1977 Welck
 4,114,353 A 9/1978 Ansbaugh et al.
 4,254,607 A 3/1981 Moore
 4,269,020 A 5/1981 Wolf
 4,292,791 A 10/1981 Lalonde
 4,375,148 A 3/1983 Beck
 4,429,518 A 2/1984 Fedeli
 4,532,708 A 8/1985 Mensing
 4,617,788 A 10/1986 Sebastian
 4,620,575 A 11/1986 Cuba et al.
 RE32,377 E 3/1987 Seyerle
 D289,524 S * 4/1987 Andersson D15/17
 4,696,153 A 9/1987 Boains, Jr.
 4,712,364 A 12/1987 Oxley
 4,771,593 A 9/1988 Lee
 4,871,629 A 10/1989 Bunyea
 4,878,338 A 11/1989 Aldred et al.
 4,922,698 A 5/1990 Taylor
 4,936,884 A 6/1990 Campbell
 5,019,113 A 5/1991 Burnell
 5,094,065 A 3/1992 Azbell
 5,136,899 A 8/1992 Hoch et al.
 5,152,382 A 10/1992 Hoch et al.
 5,163,273 A 11/1992 Wojtkowski et al.
 5,199,251 A 4/1993 Rouse et al.
 5,209,052 A * 5/1993 Carroll A01D 34/73
 56/DIG. 17
 5,213,913 A 5/1993 Anthony, III et al.
 5,224,870 A 7/1993 Weaver et al.
 5,233,820 A 8/1993 Willsie
 5,238,267 A 8/1993 Hutchison et al.
 5,259,176 A 11/1993 Kahamura et al.
 5,271,212 A 12/1993 Anderson
 5,298,821 A 3/1994 Michel
 5,299,414 A 4/1994 Long
 5,321,940 A 6/1994 Peterson
 5,327,710 A 7/1994 Plamper
 5,337,543 A 8/1994 Kitamura et al.
 5,355,661 A 10/1994 Tomiyama
 5,363,636 A 11/1994 Lamoureux
 5,401,592 A 3/1995 Gilpin et al.
 D357,691 S * 4/1995 Bryant D15/17
 5,410,866 A 5/1995 Long

5,467,586 A 11/1995 Lin
 5,473,871 A 12/1995 Fava et al.
 5,501,068 A 3/1996 Martz
 5,502,957 A 4/1996 Robertson
 5,553,675 A 9/1996 Pitzen et al.
 5,619,846 A 4/1997 Brown
 5,626,979 A 5/1997 Mitsui et al.
 5,649,750 A 7/1997 Ishii et al.
 5,663,011 A 9/1997 Bunyea et al.
 5,685,421 A 11/1997 Gilmore
 5,713,189 A 2/1998 Toman
 5,725,304 A 3/1998 Inai
 5,726,541 A 3/1998 Glenn et al.
 5,762,512 A 6/1998 Trant et al.
 5,775,077 A 7/1998 Olmr
 5,794,422 A 8/1998 Reimers et al.
 5,848,520 A 12/1998 Arfstrom et al.
 5,881,823 A 3/1999 Kabatnik et al.
 5,887,669 A 3/1999 Ostler et al.
 5,890,354 A 4/1999 Bednar
 5,894,717 A 4/1999 Yamashita et al.
 5,902,080 A 5/1999 Kopras
 5,913,802 A 6/1999 Mullet et al.
 5,934,053 A 8/1999 Fillman et al.
 5,946,895 A 9/1999 Martens
 5,983,612 A 11/1999 Bauswell et al.
 5,987,863 A 11/1999 Busboom et al.
 6,026,634 A 2/2000 Peter et al.
 6,057,608 A 5/2000 Bailey, Jr. et al.
 6,093,056 A 7/2000 Donauer et al.
 6,109,009 A 8/2000 Benson
 6,139,359 A 10/2000 Fuhreck et al.
 6,145,290 A 11/2000 Sullivan
 6,152,247 A 11/2000 Sporrer et al.
 6,168,881 B1 1/2001 Fischer et al.
 6,181,032 B1 1/2001 Marshall et al.
 D440,981 S * 4/2001 Burch D15/17
 6,223,835 B1 5/2001 Habedank et al.
 6,237,698 B1 5/2001 Carrier et al.
 6,253,534 B1 7/2001 Hunter et al.
 6,283,235 B1 9/2001 Sporrer et al.
 6,304,058 B2 10/2001 Watson et al.
 6,347,502 B1 2/2002 deVries
 6,354,414 B1 3/2002 Sueshige et al.
 6,357,533 B1 3/2002 Bucholz et al.
 6,367,235 B1 4/2002 Moynihan
 6,376,942 B1 4/2002 Burger et al.
 6,390,225 B2 5/2002 Velke et al.
 6,415,681 B1 7/2002 Porter et al.
 6,434,917 B1 8/2002 Bartel
 6,460,626 B2 10/2002 Carrier
 6,461,088 B2 10/2002 Potter et al.
 6,487,840 B1 12/2002 Turner
 6,487,857 B1 12/2002 Poplawski et al.
 6,502,949 B1 1/2003 Horiyama et al.
 6,525,511 B2 3/2003 Kubale et al.
 6,530,200 B1 3/2003 Minoura et al.
 6,551,123 B1 4/2003 Schaeffleier et al.
 6,560,952 B2 5/2003 Velke et al.
 6,568,089 B1 5/2003 Popik et al.
 6,581,703 B2 6/2003 Hammonds
 6,591,593 B1 7/2003 Brandon et al.
 6,591,711 B2 7/2003 Porter et al.
 6,604,348 B2 8/2003 Hunt
 D482,700 S * 11/2003 Lancaster D15/17
 6,655,119 B2 * 12/2003 Hasei A01D 34/826
 56/DIG. 17
 6,662,895 B1 12/2003 Bednar
 6,672,058 B1 1/2004 Langenfeld et al.
 6,681,877 B2 1/2004 Ono et al.
 6,688,091 B2 2/2004 Ishimori
 6,701,825 B1 3/2004 Langenfeld
 6,708,805 B2 3/2004 Samejima et al.
 6,715,284 B1 4/2004 Poplawski et al.
 6,717,281 B1 4/2004 Brandon et al.
 6,729,115 B2 5/2004 Bartel
 6,729,413 B2 5/2004 Turner et al.
 6,767,597 B2 7/2004 Onishi et al.
 6,775,976 B1 8/2004 Phanco et al.

(56)

References Cited

U.S. PATENT DOCUMENTS

6,782,797 B1	8/2004	Brandenburg et al.	8,047,310 B2	11/2011	Kallevig	
6,798,160 B2	9/2004	Wakitani et al.	8,055,399 B2	11/2011	Wyatt et al.	
6,810,589 B2	11/2004	Lagaly et al.	8,056,653 B2	11/2011	Hunt et al.	
6,843,056 B1	1/2005	Langenfeld et al.	8,100,204 B2	1/2012	Dong et al.	
6,856,035 B2	2/2005	Brandon et al.	8,104,934 B2	1/2012	Probasco	
6,868,657 B2	3/2005	Bauer et al.	8,149,587 B2	4/2012	Baran et al.	
6,886,677 B2	5/2005	Rupiper et al.	8,181,717 B2	5/2012	Turner et al.	
6,945,133 B2	9/2005	Rush et al.	8,191,342 B2	6/2012	Ishii et al.	
6,948,299 B2	9/2005	Osborne	8,207,693 B2	6/2012	Hauser et al.	
6,957,531 B1	10/2005	Phanco et al.	8,234,026 B2	7/2012	Wyatt et al.	
6,963,796 B2	11/2005	Larson et al.	8,235,559 B2	8/2012	Probasco	
6,964,164 B1	11/2005	Langenfeld	8,245,509 B1	8/2012	Langenfeld et al.	
6,968,687 B1	11/2005	Poplawski et al.	8,296,003 B2	10/2012	Wyatt et al.	
6,972,234 B1	12/2005	Phanco et al.	8,312,937 B2	11/2012	Turner et al.	
6,973,768 B2	12/2005	Samejima et al.	8,418,452 B1	4/2013	Phanco et al.	
6,981,780 B2	1/2006	Einav	8,450,953 B2	5/2013	Hauser et al.	
6,988,570 B2	1/2006	Takeuchi	8,490,722 B2	7/2013	Koga et al.	
7,017,327 B2	3/2006	Hunt et al.	8,544,570 B2	10/2013	Ishii et al.	
7,047,736 B1	5/2006	Langenfeld et al.	8,548,694 B2	10/2013	Wyatt et al.	
7,051,499 B2	5/2006	Goto et al.	D693,373 S *	11/2013	Shiotsuki	D15/17
7,111,545 B1	9/2006	Langenfeld	8,572,939 B2	11/2013	Koike et al.	
7,121,092 B1	10/2006	Phanco et al.	8,573,324 B2	11/2013	Turner et al.	
7,127,041 B1	10/2006	Houck	8,579,055 B2	11/2013	Sasahara et al.	
7,127,877 B2	10/2006	Curran	D694,782 S *	12/2013	Roth	D15/17
7,127,889 B1	10/2006	Bennett et al.	D696,301 S *	12/2013	DeLeon	D15/17
7,165,639 B2	1/2007	Delaney et al.	8,657,041 B2	2/2014	Ishii et al.	
7,194,850 B2	3/2007	Asahara et al.	8,668,033 B2	3/2014	Koike et al.	
7,213,662 B2	5/2007	Crumly et al.	8,668,036 B2	3/2014	Wyatt et al.	
7,225,617 B1	6/2007	Langenfeld et al.	8,689,551 B1	4/2014	Phanco et al.	
7,226,387 B2	6/2007	Thompson et al.	8,783,391 B2	7/2014	Porter et al.	
7,231,994 B2	6/2007	Buglione et al.	D710,396 S *	8/2014	Nie	D15/17
7,270,200 B2	9/2007	Goto et al.	8,794,660 B1	8/2014	Stover et al.	
7,299,610 B2	11/2007	Piontek	8,800,279 B2	8/2014	Kita et al.	
7,308,790 B1	12/2007	Bennett et al.	8,838,311 B2	9/2014	Koike et al.	
7,325,388 B2	2/2008	Wright et al.	8,844,658 B2	9/2014	Wyatt et al.	
7,328,576 B1	2/2008	Langenfeld et al.	8,849,490 B2	9/2014	Wyatt et al.	
7,340,890 B1	3/2008	Poplawski et al.	8,850,782 B2	10/2014	Haraqia et al.	
7,353,651 B2	4/2008	Adkins et al.	8,880,300 B2	11/2014	Gamble et al.	
7,383,683 B1	6/2008	Rawski	8,965,630 B2	2/2015	Wyatt et al.	
7,392,643 B2 *	7/2008	Warashina	9,002,585 B2	4/2015	Porter et al.	
	 A01D 34/826	9,114,703 B1	8/2015	Bennett et al.	
		56/17	9,114,798 B1	8/2015	Fox et al.	
7,392,853 B2 *	7/2008	Baran	9,194,473 B1	11/2015	Hauser et al.	
	 A01D 34/84	D745,061 S *	12/2015	DeLeon	D15/17
		172/540	9,248,737 B2	2/2016	Iwaki et al.	
D574,860 S *	8/2008	Potts	9,288,939 B2	3/2016	Porter et al.	
	 D15/17	9,301,443 B2	4/2016	Hashima et al.	
7,412,828 B1	8/2008	Bennett et al.	9,307,695 B2 *	4/2016	Nishihara	A01D 34/73
7,429,430 B2	9/2008	Mooty et al.	9,308,817 B1	4/2016	Phanco et al.	
7,451,865 B2	11/2008	Eavenson, Sr. et al.	D755,858 S *	5/2016	Brown	D15/17
7,454,908 B1	11/2008	Langenfeld et al.	9,381,639 B2	7/2016	Werner et al.	
7,458,432 B2	12/2008	Mayer et al.	9,403,435 B2	8/2016	Bejcek	
7,540,131 B2	6/2009	Stover et al.	9,408,343 B2	8/2016	Wyatt et al.	
D598,475 S *	8/2009	Roth	9,409,553 B2	8/2016	Nakamura et al.	
	 D15/17	9,409,578 B2	8/2016	Wyatt et al.	
7,578,116 B1	8/2009	Howell	9,420,740 B2	8/2016	Ishii et al.	
7,590,768 B2	9/2009	Gormley	9,435,324 B2	9/2016	Richardson et al.	
7,594,377 B1	9/2009	Jansen et al.	9,468,144 B2	10/2016	Kurioka et al.	
7,596,636 B2	9/2009	Gormley	9,480,200 B1	11/2016	Patridge	
7,610,975 B1	11/2009	Gust et al.	9,492,919 B2	11/2016	Roehm et al.	
7,610,986 B2	11/2009	Ohashi	9,499,199 B1	11/2016	Laymon et al.	
D609,251 S *	2/2010	Roth	9,538,699 B1	1/2017	Bejcek et al.	
	 D15/17	9,538,706 B2	1/2017	Haun	
7,661,486 B2	2/2010	Turner et al.	9,616,736 B2	4/2017	Ito et al.	
7,673,712 B2	2/2010	Lida et al.	D786,310 S *	5/2017	Southwell	D15/17
7,686,108 B2	2/2010	Piontek	9,656,687 B2	5/2017	Koike et al.	
7,712,294 B2	2/2010	Wright et al.	9,699,964 B2 *	7/2017	Roth	A01D 34/81
7,721,517 B2	2/2010	Hunt et al.	9,706,706 B2	7/2017	Barendrecht	
7,731,398 B2	2/2010	Probasco	9,725,114 B1	8/2017	Brown et al.	
7,735,592 B2	2/2010	Bellot et al.	9,725,115 B1	8/2017	Hauser et al.	
7,784,254 B2	8/2010	Bever	9,731,760 B2	8/2017	Ito	
7,798,939 B2	9/2010	Musat et al.	9,750,183 B2	9/2017	Haun	
7,810,964 B2	10/2010	Probasco	9,750,191 B2	9/2017	Richardson et al.	
7,826,232 B2	11/2010	Von Arx et al.	9,764,734 B1	9/2017	Brown	
7,841,176 B1	11/2010	Langenfeld et al.	9,765,761 B1	9/2017	Fox et al.	
7,870,711 B2	1/2011	Koehn	9,765,870 B1	9/2017	Fox et al.	
7,908,833 B2	3/2011	Nicholson et al.	D801,394 S *	10/2017	Southwell	D15/17
7,918,305 B2	4/2011	Scherbring et al.	9,820,441 B2	11/2017	Heathcoat et al.	
8,028,520 B1	10/2011	Rawski	9,839,179 B2	12/2017	Stover et al.	
8,028,776 B2	10/2011	Bong et al.				

(56)

References Cited

U.S. PATENT DOCUMENTS

9,888,626 B2* 2/2018 Gilpatrick A01D 34/733
 9,968,031 B2 5/2018 Bejcek et al.
 D837,266 S * 1/2019 Wong D15/17
 D837,267 S * 1/2019 Wong D15/17
 D837,268 S * 1/2019 Burrows D15/17
 D849,799 S * 5/2019 Bollman D15/17
 10,285,328 B2* 5/2019 Kurioka A01D 34/68
 10,426,084 B2 10/2019 Ito et al.
 D873,302 S * 1/2020 Southwell D15/17
 D902,262 S * 11/2020 Hoover D15/17
 11,122,737 B2* 9/2021 Xu A01D 34/78
 11,246,260 B2* 2/2022 Xu A01D 34/78
 D949,206 S * 4/2022 Cmich D15/17
 2001/0001170 A1 5/2001 Velke et al.
 2002/0056263 A1 5/2002 Schaedler
 2003/0168272 A1 9/2003 Ono et al.
 2003/0209000 A1 11/2003 Mannon
 2003/0222607 A1 12/2003 Simizu et al.
 2005/0016320 A1 1/2005 Porter
 2006/0010844 A1 1/2006 Angott
 2006/0042216 A1 3/2006 Warashina et al.
 2006/0162310 A1 7/2006 Dittmer
 2006/0168933 A1 8/2006 Hill, Jr.
 2007/0074497 A1 4/2007 Myers
 2008/0072556 A1 3/2008 Tegtmeier et al.
 2008/0234096 A1 9/2008 Joshi et al.
 2009/0182470 A1 7/2009 Garvey et al.
 2010/0043378 A1 2/2010 Abernethy
 2010/0085745 A1 4/2010 Kristiansen et al.
 2010/0117594 A1 5/2010 Bizzontz
 2010/0139231 A1 6/2010 Washburn, IV
 2012/0228041 A1 9/2012 Borinato
 2012/0233975 A1 9/2012 Coussins
 2013/0008682 A1 1/2013 Turner et al.
 2013/0104509 A1 5/2013 MacKinnon et al.
 2013/0155657 A1 6/2013 Werner et al.
 2013/0327007 A1 12/2013 Eavenson, Sr
 2014/0100743 A1 4/2014 Foster et al.
 2014/0182257 A1 7/2014 von Rentzell
 2014/0196425 A1 7/2014 Lewis
 2015/0052869 A1 2/2015 Roth et al.
 2015/0082763 A1 3/2015 Nishihara
 2015/0173299 A1 6/2015 Heathcoat et al.
 2015/0271997 A1 10/2015 Kurioka et al.
 2015/0271998 A1 10/2015 Kurioka et al.
 2016/0183451 A1 6/2016 Conrad et al.
 2016/0242355 A1 8/2016 Talaski
 2016/0288829 A1 10/2016 Ito et al.
 2017/0020067 A1 1/2017 Haun
 2017/0021861 A1 1/2017 Ito et al.
 2017/0055443 A1 3/2017 Fuji et al.
 2017/0105339 A1 4/2017 Yang et al.
 2017/0120922 A1 5/2017 Schaedler et al.
 2017/0245426 A1 8/2017 Kuriyagawa et al.
 2017/0303469 A1 10/2017 Schaedler et al.
 2018/0146616 A1 5/2018 Fukano et al.
 2018/0152121 A1 5/2018 Fukano et al.
 2018/0160620 A1 6/2018 Wang et al.
 2018/0231238 A1 8/2018 Burch et al.
 2019/0045707 A1 2/2019 Patridge
 2019/0200521 A1 7/2019 Aboumrad
 2019/0335654 A1 11/2019 Ito
 2020/0000023 A1 1/2020 Chung
 2020/0052558 A1 2/2020 Kouda et al.
 2020/0100426 A1* 4/2020 Kurihara A01D 34/63
 2020/0253115 A1 8/2020 Feng et al.
 2020/0404840 A1 12/2020 Xu et al.
 2021/0289697 A1 9/2021 Kurihara et al.
 2021/0321564 A1 10/2021 Yamaoka et al.

FOREIGN PATENT DOCUMENTS

CN 1802890 A 7/2006
 CN 102684235 A 9/2012
 CN 102986361 A 3/2013

CN 202819008 U 3/2013
 CN 203251656 U 10/2013
 CN 203369100 U 1/2014
 CN 203423971 U 2/2014
 CN 103703918 A 4/2014
 CN 104363749 A 2/2015
 CN 104669226 6/2015
 CN 204681890 U 10/2015
 CN 105075497 A 11/2015
 CN 105082096 11/2015
 CN 204796177 U 11/2015
 CN 205363843 U 7/2016
 CN 205363844 U 7/2016
 CN 205466090 U 8/2016
 CN 205546539 U 9/2016
 CN 106612971 5/2017
 CN 206323814 U 7/2017
 CN 206353985 U 7/2017
 CN 206423166 U 8/2017
 CN 107302864 A 10/2017
 CN 206855413 U 1/2018
 CN 207139764 U 3/2018
 CN 207240145 U 4/2018
 CN 207269396 U 4/2018
 CN 207340527 U 5/2018
 CN 108207334 6/2018
 CN 108790946 11/2018
 DE 3019256 11/1981
 DE 3232895 A1 3/1984
 DE 1105557 A1 9/1992
 DE 9311901 U1 12/1993
 DE 9319361 U1 2/1994
 DE 29513651 U1 1/1997
 DE 20309420 U1 9/2003
 DE 102006058958 A1 6/2008
 DE 102012213047 A1 1/2014
 DE 102012218601 A1 4/2014
 DE 202017100938 U1 3/2017
 EP 0499879 A1 8/1992
 EP 0528478 A1 2/1993
 EP 0898870 A1 3/1999
 EP 0957526 11/1999
 EP 0981944 A1 3/2000
 EP 1348328 10/2003
 EP 1447281 A1 8/2004
 EP 1498018 A1 1/2005
 EP 2357107 A1 8/2011
 EP 2798937 11/2014
 EP 3695702 A1 8/2020
 FR 2756536 A1 6/1998
 GB 2037138 A 7/1980
 GB 2302202 A 1/1997
 GB 2332355 A 6/1999
 JP 2003180118 7/2003
 JP 2015188337 A 11/2015
 JP 2018102234 A 7/2018
 JP 2018102235 A 7/2018
 SU 1743448 A1 6/1992
 WO 2000032462 A1 6/2000
 WO 2000038255 A1 6/2000
 WO 2010048561 A1 4/2010
 WO 2016/037184 A1 3/2016
 WO 2016037184 A1 3/2016
 WO 2017173944 A1 10/2017
 WO 2017173945 A1 10/2017

OTHER PUBLICATIONS

Greenworks, Gree Bo electric brush cutter 80V, <http://goods.jc001.cn/detail/4444528.html>, 12 pages.
 CIPO, office action issued on Canadian patent application 3,114,468, dated Jun. 21, 2021, 6 pages.
 Australian Patent Office, examination report issued of Australian patent application No. 2019346954, dated Feb. 16, 2022, 3 pages.
 EPO, extended European Search Report issued on European patent application No. 19866834.5, dated Jul. 22, 2021, 10 pgs.
 You Tube video—https://www.youtube.com/watch?v=iORCGT_K7mc.

(56)

References Cited

OTHER PUBLICATIONS

Owner's manual for Model No. HRN216VKA Lawn Mower.
U.S. Patent and Trademark Office, Non-Final Office Action issued in U.S. Appl. No. 17/825,815, dated Jul. 25, 2022, 13 pgs.
U.S. Patent and Trademark Office, Non-Final Office Action issued in U.S. Appl. No. 17/863,038, dated Nov. 29, 2022, 21 pgs.
U.S. Patent and Trademark Office, Final Office Action issued in U.S. Appl. No. 17/825,815, dated Nov. 15, 2022, 39 pages.
U.S. Patent and Trademark Office, Non-Final Office Action issued in U.S. Appl. No. 29/865,427, dated Nov. 25, 2022, nine (9) pages.
U.S. Patent and Trademark Office, Non-Final Office Action issued in U.S. Appl. No. 29/865,321, dated Nov. 25, 2022, 15 pages.

* cited by examiner

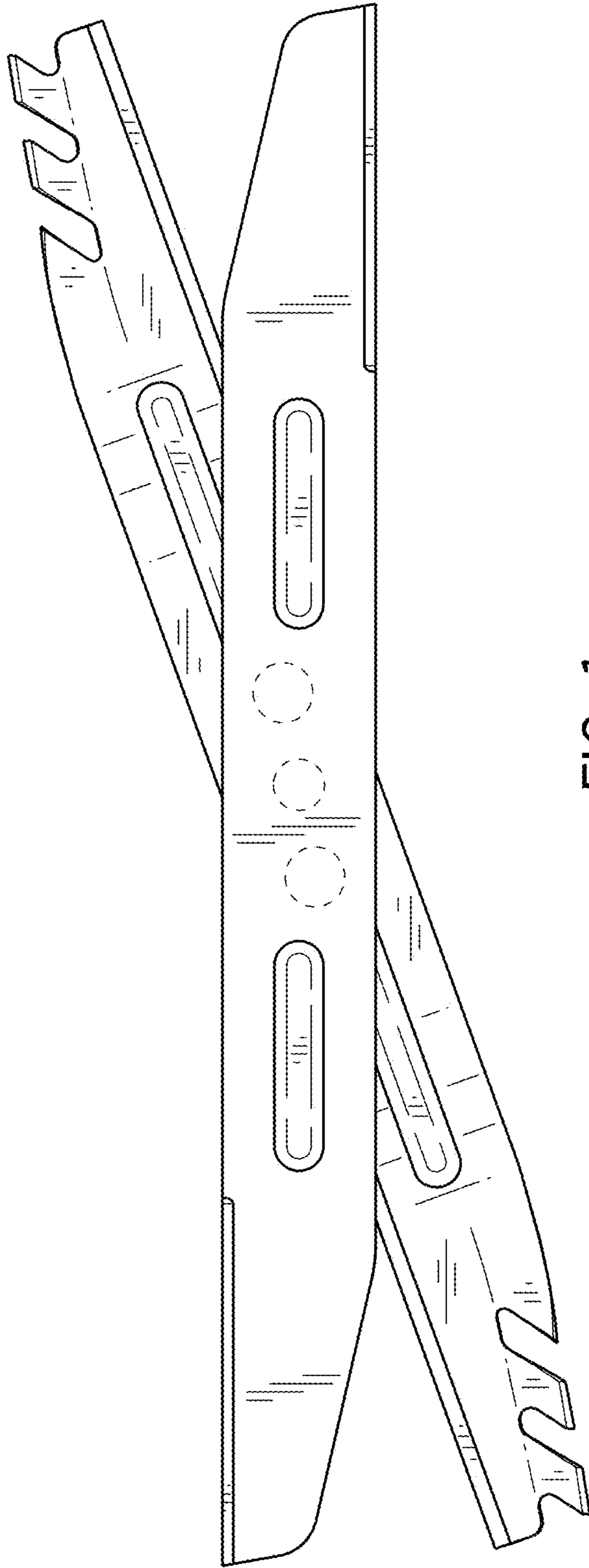

FIG. 1

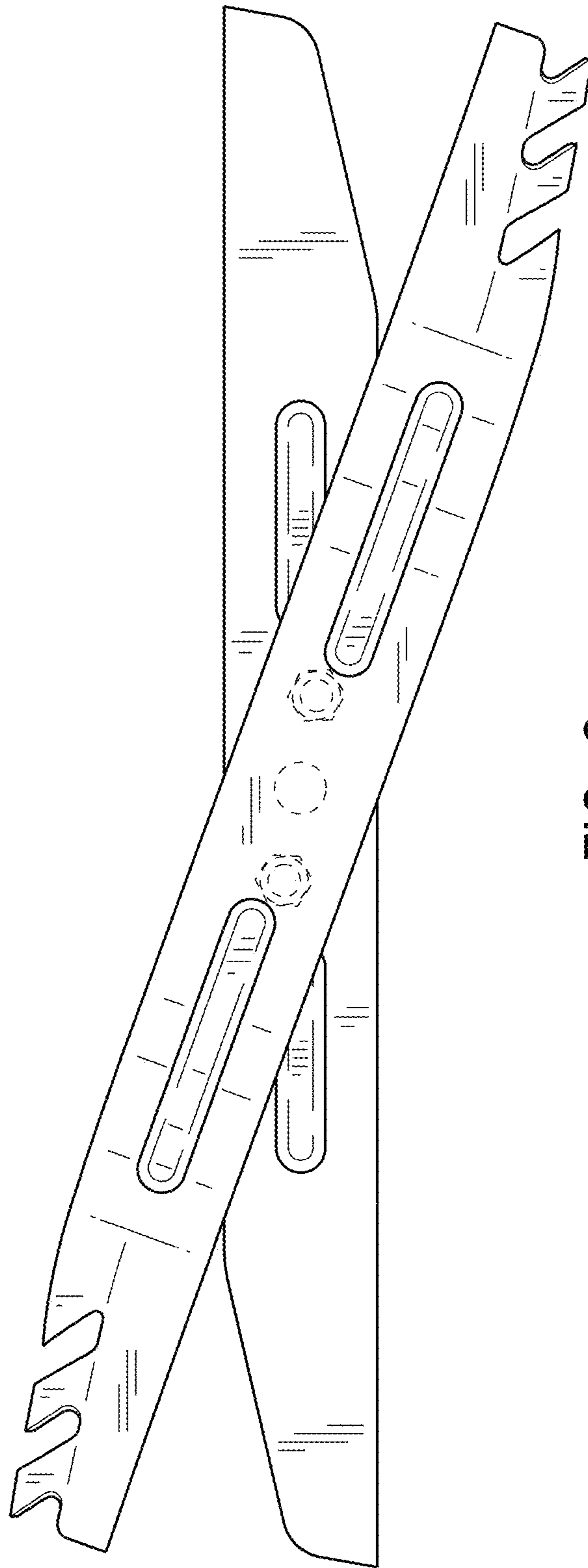

FIG. 2

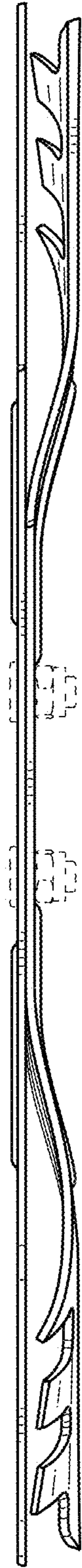

FIG. 3



FIG. 4