



US00D987571S

(12) **United States Design Patent** (10) **Patent No.:** **US D987,571 S**  
**Mills** (45) **Date of Patent:** **\*\* May 30, 2023**

(54) **BATTERY BOX FOR A TRUCK**  
(71) Applicant: **PACCAR Inc**, Bellevue, WA (US)  
(72) Inventor: **Steven R. Mills**, Denton, TX (US)  
(73) Assignee: **PACCAR Inc**, Bellevue, WA (US)  
(\*\*) Term: **15 Years**  
(21) Appl. No.: **29/733,781**  
(22) Filed: **May 6, 2020**  
(51) **LOC (14) Cl.** ..... **13-02**  
(52) **U.S. Cl.**  
USPC ..... **D13/119**  
(58) **Field of Classification Search**  
USPC ..... D13/101, 102, 103, 104, 105, 106, 107,  
D13/108, 109, 110, 118, 119, 120, 184,  
D13/199; D14/432; D15/28  
CPC .. H01M 50/20; H01M 50/202; H01M 50/249;  
H01M 10/44; H01M 10/46; Y02E 60/10;  
Y02E 60/50; B62D 25/20; B62D  
25/2027; B60K 1/04  
See application file for complete search history.

(56) **References Cited**  
U.S. PATENT DOCUMENTS  
D432,492 S 10/2000 Waskow et al.  
D433,378 S 11/2000 Waskow  
D440,984 S \* 4/2001 Norfleet ..... D25/63  
D592,134 S \* 5/2009 Brockington ..... D13/119  
D657,748 S \* 4/2012 Hargreaves ..... D13/156  
D684,535 S \* 6/2013 McDonald, II ..... D13/119  
D719,503 S \* 12/2014 Kouyanagi ..... D13/102  
D777,216 S \* 1/2017 Allemeier ..... D15/28  
9,882,252 B2 \* 1/2018 Marji ..... H01M 10/6572  
D825,465 S \* 8/2018 Deng ..... D13/119  
D881,812 S \* 4/2020 Yang ..... D13/103  
10,637,024 B2 \* 4/2020 Suzuki ..... B60L 50/64

OTHER PUBLICATIONS  
“T800,” Kenworth Truck Company, 2002, 32-page brochure.  
“T800,” Kenworth Truck Company, 2003, 32-page brochure.  
“T800,” Kenworth Truck Company, 2005, 28-page brochure.  
“T800,” Kenworth Truck Company, 2009, 28-page brochure.  
“T800B,” Kenworth Truck Company, 1993, 8-page brochure.  
Peterbilt Motors Company, “The Working Class,” Sep. 1976, 6-page brochure.  
“The World’s Best,” Kenworth Truck Company, 1992, 12-page brochure.  
“W900,” Kenworth Truck Company, 1996, 7-page brochure.  
“W900,” Kenworth Truck Company, 2002, 32-page brochure.  
“W900,” Kenworth Truck Company, 2005, 28-page brochure.  
“W900,” Kenworth Truck Company, 2009, 28-page brochure.  
Kenworth Truck Company, “W900L AeroCab,” 1994, 2-page brochure.

(Continued)

*Primary Examiner* — Derrick E Holland  
(74) *Attorney, Agent, or Firm* — Seed IP Law Group LLP

(57) **CLAIM**  
The ornamental design for a battery box for a truck, as shown and described.

**DESCRIPTION**

FIG. 1 is an isometric view of a battery box for a truck, showing my new design.  
FIG. 2 is a front elevational view thereof.  
FIG. 3 is a rear elevational view thereof.  
FIG. 4 is a left side elevational view thereof.  
FIG. 5 is a right side elevational view thereof.  
FIG. 6 is a top plan view thereof; and,  
FIG. 7 is a bottom plan view thereof.  
Stippling in the drawings represents the three-dimensional contours of the design, and is not intended to indicate surface decoration. The broken lines shown in the drawings depict portions of the battery box for a truck that form no part of the claimed design.

**1 Claim, 5 Drawing Sheets**

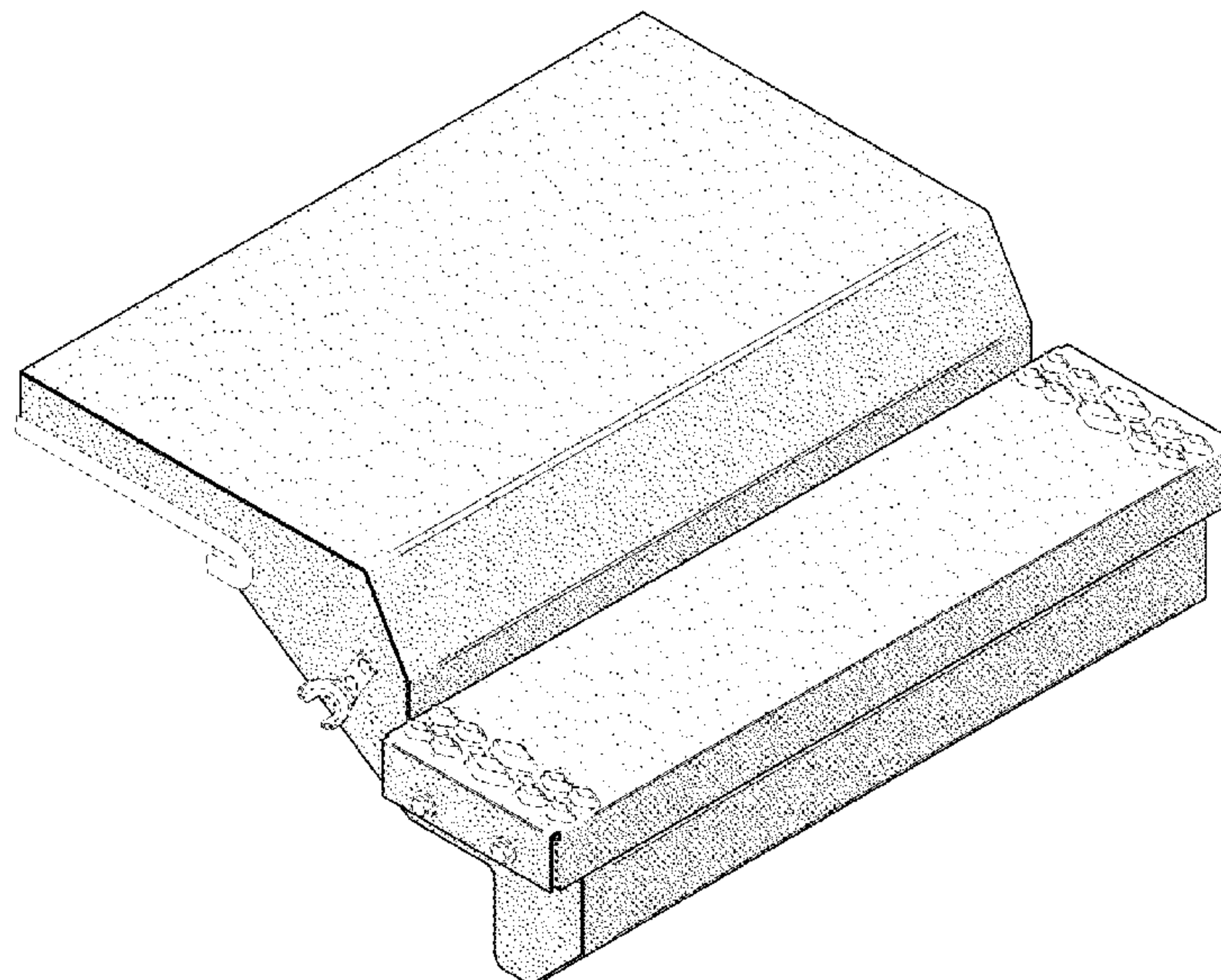

(56)

**References Cited**

## OTHER PUBLICATIONS

Kenworth Truck Company, "AeroCab," 1993, 5-page brochure.  
 "AeroCab," Kenworth Truck Company, as early as 1995, 3-page brochure.  
 "C500B," Kenworth Truck Company, as early as 1990, 4-page brochure.  
 Peterbilt Motors Company, "Class Pays, Medium Duty," Sep. 2000, 12-page brochure.  
 "Class Pays, Truck Models," Peterbilt Motors Company, Mar. 2005, 24-page brochure.  
 "Class Pays," Peterbilt Motors Company, Nov. 1998, 10-page brochure.  
 Peterbilt Motors Company, "Class Pays," Sep. 1997, 10-page brochure.  
 "Class Pays, Construction Trucks," Peterbilt Motors Company, Nov. 2003, 16-page brochure.  
 "Kenworth Truck Models," Kenworth Truck Company, 2010, 16-page brochure.  
 Peterbilt Motors Company, "Model 330," Oct. 1997, 3-page brochure.  
 Peterbilt Motors Company, "Model 379," Apr. 2005, 2-page brochure.  
 Peterbilt Motors Company, "Model 379," Mar. 1996, 5-page brochure.  
 Peterbilt Motors Company, "Rest with Class," Apr. 1978, 4-page brochure.  
 "T170 Class 5," Kenworth Truck Company, 2008, 4-page brochure.  
 "T270 Class 6 and T370 Class 7," Kenworth Truck Company, 2008, 6-page brochure.  
 "T270 Class 6 and T370 Class 7," Kenworth Truck Company, 2009, 6-page brochure.  
 "T270 Class 6 and T370 Class 7 Hybrid," Kenworth Truck Company, 2009, 6-page brochure.  
 "T680," Kenworth Truck Company, 2013, 34-page brochure.  
 "T680," Kenworth Truck Company, 2016, 34-page brochure.

"T880," Kenworth Truck Company, 2017, 32-page brochure.  
 "Model 579," Peterbilt Motors Company, Oct. 2013, 13-page brochure.  
 "Medium Duty," Peterbilt Motors Company, 2013, 9-page brochure.  
 "On-Highway," Peterbilt Motors Company, 2013, 13-page brochure.  
 "Vocational," Peterbilt Motors Company, 2013, 11-page brochure.  
 "T440," Kenworth Truck Company, 2010, 6-page brochure.  
 "T470," Kenworth Truck Company, 2010, 6-page brochure.  
 "T470H," Kenworth Truck Company, 2009, 2-page brochure.  
 "Model 220," Peterbilt Motors Company, 2019, 2-page brochure.  
 "220EV," Peterbilt Motors Company, 2020, 5-page brochure.  
 "Model 337," Peterbilt Motors Company, 2020, 2-page brochure.  
 "Model 389," Peterbilt Motors Company, 2019, 2-page brochure.  
 "Model 348," Peterbilt Motors Company, 2019, 2-page brochure.  
 "Model 520," Peterbilt Motors Company, 2019, 2-page brochure.  
 "Model 567," Peterbilt Motors Company, 2020, 16-page brochure.  
 "567 Heritage," Peterbilt Motors Company, 2017, 2-page brochure.  
 "Model 579," Peterbilt Motors Company, 2019, 28-page brochure.  
 "C500," Kenworth Truck Company, 2012, 2-page brochure.  
 "T680," Kenworth Truck Company, 2019, 40-page brochure.  
 "T800," Kenworth Truck Company, 2012, 28-page brochure.  
 "T440/T470," Kenworth Truck Company, 2015, 8-page brochure.  
 "K270E/K370E," Kenworth Truck Company, 2020, 4-page brochure.  
 "T170/T270/T370," Kenworth Truck Company, 2019, 16-page brochure.  
 "K270/K370," Kenworth Truck Company, 2014, 12-page brochure.  
 "W990," Kenworth Truck Company, 2018, 32-page brochure.  
 "T880," Kenworth Truck Company, 2019, 36-page brochure.  
 "Model 367," Peterbilt Motors Company, <https://www.peterbilt.com/trucks/vocational/model-367>, retrieved Nov. 20, 2020, 12 pages.  
 "Model 365," Peterbilt Motors Company, <https://www.peterbilt.com/trucks/vocational/model-365>, retrieved Nov. 20, 2020, 11 pages.  
 "Model 325," Peterbilt Motors Company, <https://www.peterbilt.com/trucks/medium-duty/model-325>, retrieved Nov. 20, 2020, 12 pages.

\* cited by examiner



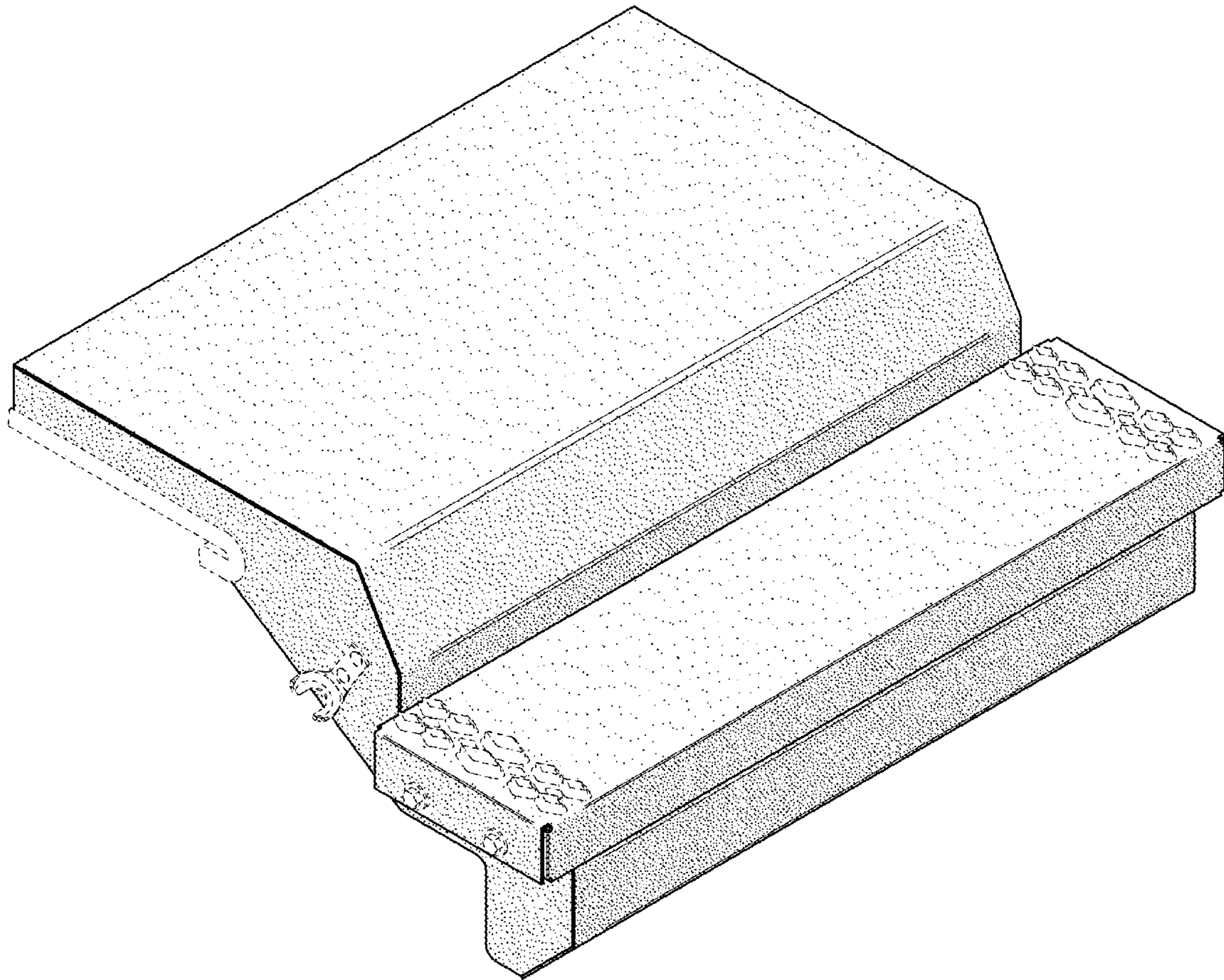

***FIG. 1***

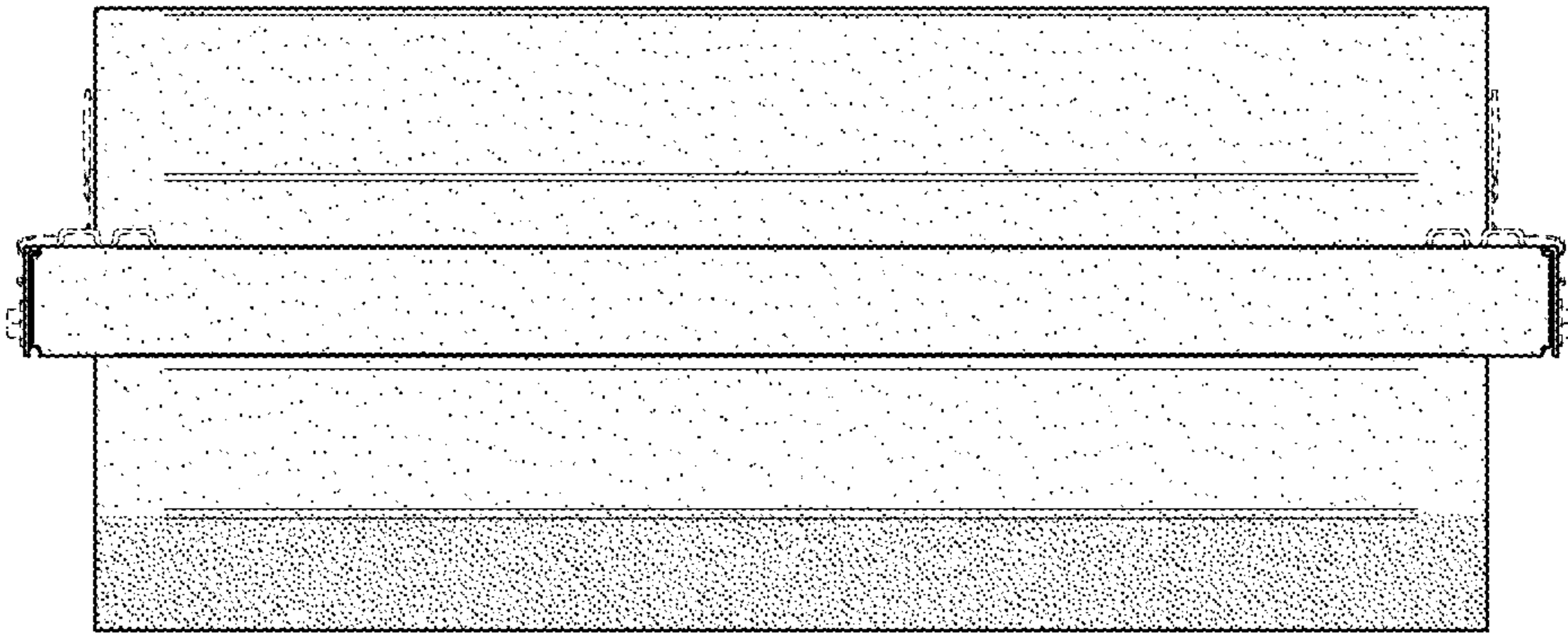

***FIG. 2***



***FIG. 3***

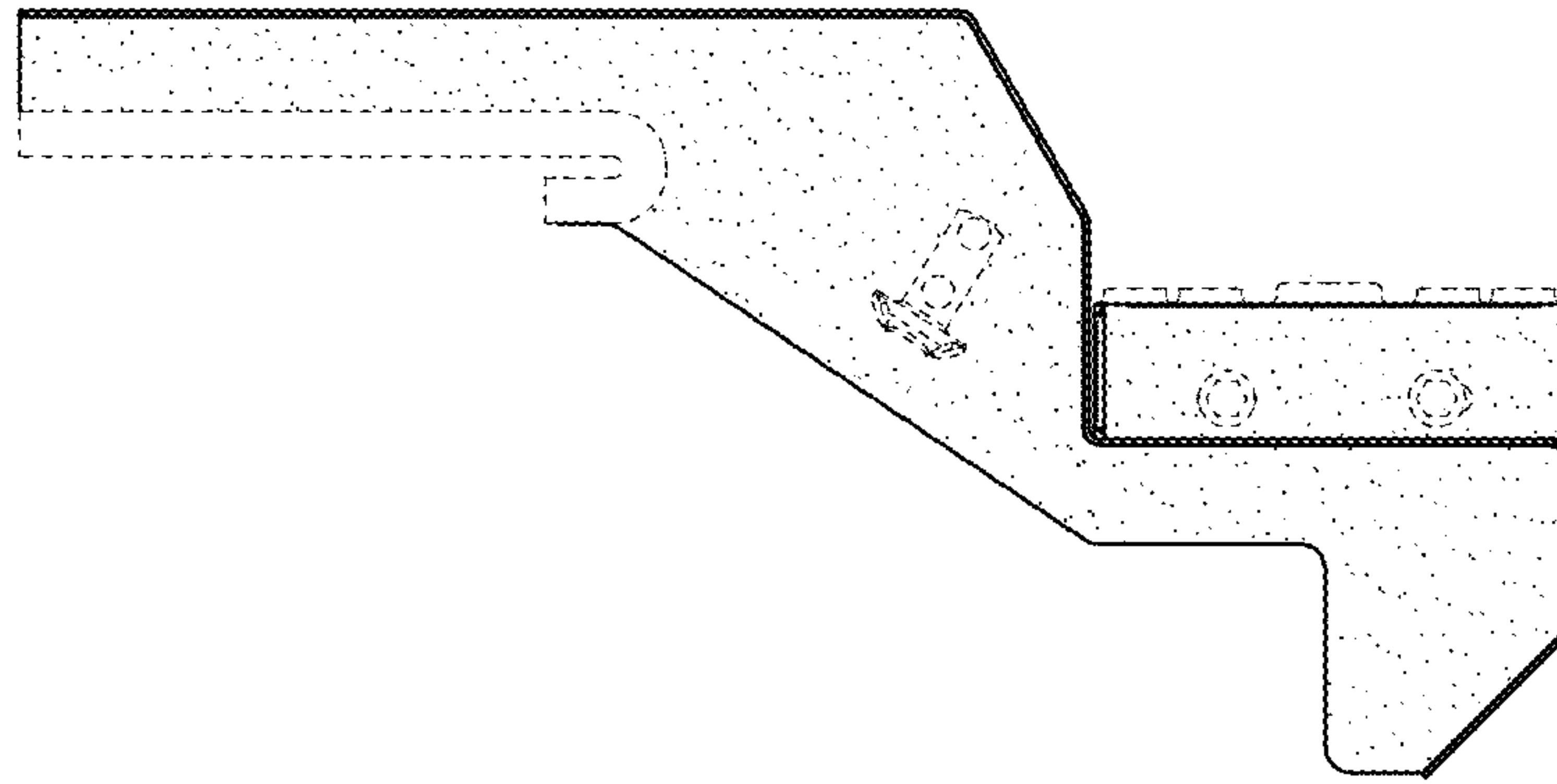

***FIG. 4***

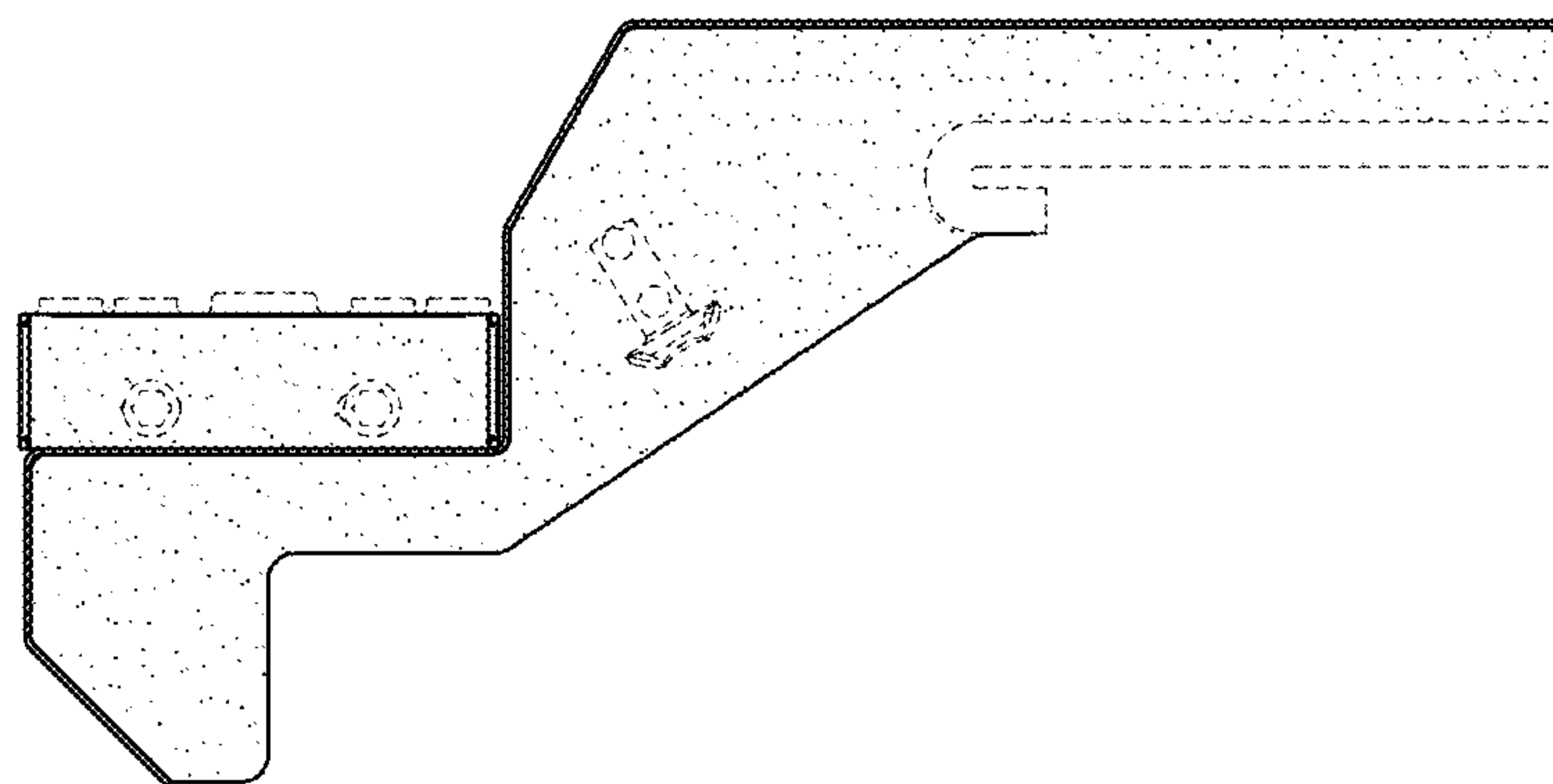

***FIG. 5***



**FIG. 6**

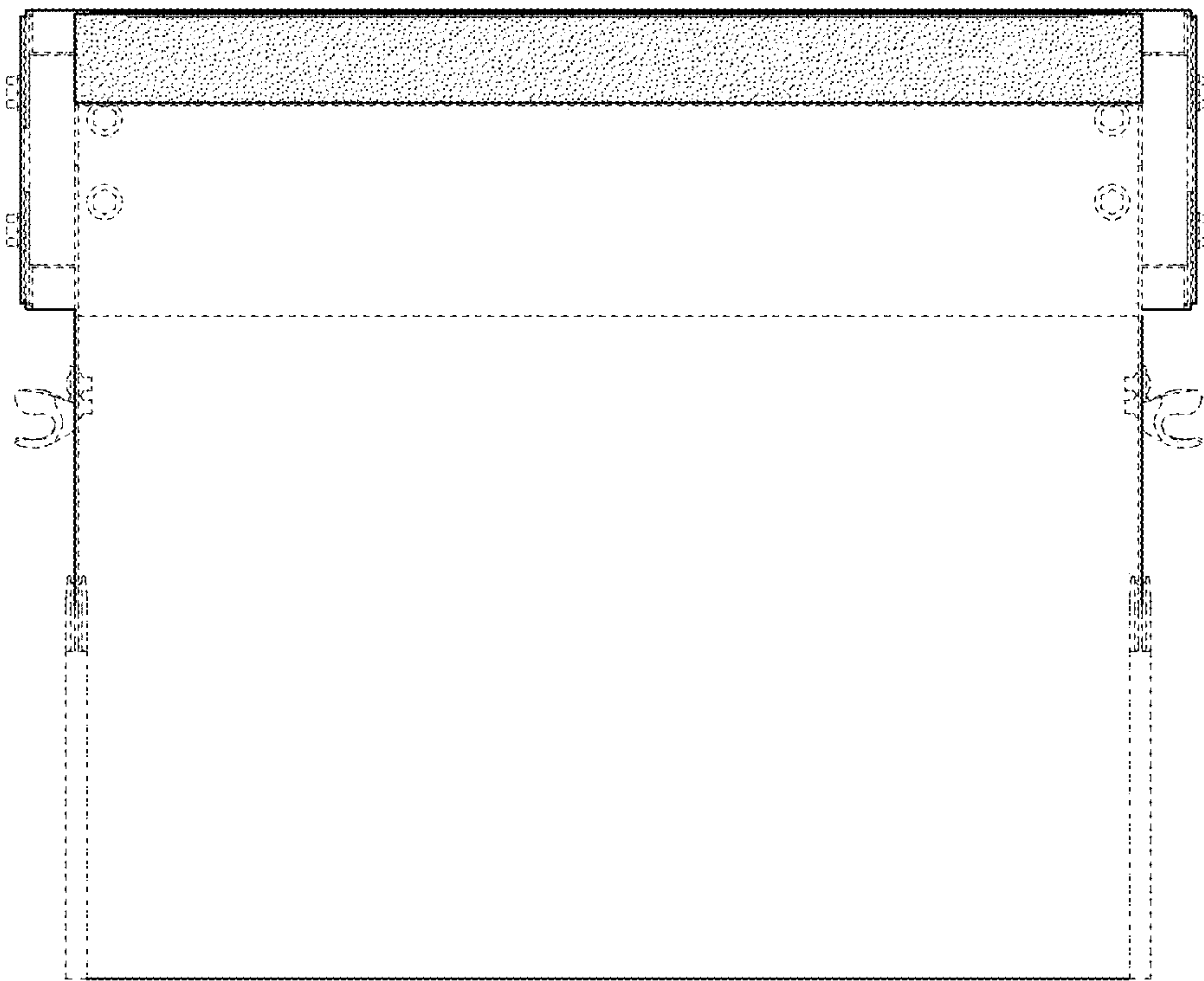

**FIG. 7**