



US00D987559S

(12) **United States Design Patent**  
**Petzl**

(10) **Patent No.:** **US D987,559 S**

(45) **Date of Patent:** **\*\* May 30, 2023**

(54) **BATTERY FOR HEADLAMP**

(71) Applicant: **ZEDEL**, Crolles (FR)

(72) Inventor: **Paul Petzl**, Barraux (FR)

(73) Assignee: **ZEDEL**, Crolles (FR)

(\*\*) Term: **15 Years**

(21) Appl. No.: **29/804,521**

(22) Filed: **Aug. 20, 2021**

(30) **Foreign Application Priority Data**

Feb. 24, 2021 (EM) ..... 008442859

(51) **LOC (14) Cl.** ..... **13-02**

(52) **U.S. Cl.**  
USPC ..... **D13/103**

(58) **Field of Classification Search**

USPC ..... D13/102–106, 110, 118–119, 184  
CPC . Y02E 60/10; H01M 2220/30; H01M 50/209;  
H01M 50/213; H01M 50/183; H01M  
50/10; H01M 50/529; H01M 50/531;  
H01M 10/0525; H01M 10/0436; H01M  
10/052; H01M 10/0565; H01M 10/30;  
H01M 10/345; H01M 10/425; H01M  
2010/0495; B25F 5/02; B25F 5/00; A61B  
2017/00734

See application file for complete search history.

(56) **References Cited**

**U.S. PATENT DOCUMENTS**

D457,133 S \* 5/2002 Yoneyama ..... D13/103  
D569,794 S \* 5/2008 Zhang ..... D13/103

D592,131 S \* 5/2009 Heinzen ..... D13/103  
D643,400 S \* 8/2011 Wahl ..... D14/203.5  
D677,816 S \* 3/2013 Petzl ..... D26/39  
D695,217 S \* 12/2013 Dasbach ..... D13/110  
D726,356 S \* 4/2015 Windom ..... D26/113  
D785,561 S \* 5/2017 Lyman ..... D13/103  
D805,667 S \* 12/2017 Green ..... D26/39  
D828,599 S \* 9/2018 Petzl ..... D26/39  
D851,307 S \* 6/2019 Sharrah ..... D26/39  
D922,941 S \* 6/2021 Antonio ..... D13/103  
D939,431 S \* 12/2021 Thorne ..... D13/103

\* cited by examiner

*Primary Examiner* — Nathaniel D. Buckner

(74) *Attorney, Agent, or Firm* — Oliff PLC

(57) **CLAIM**

The ornamental design for a battery for headlamp, as shown and described.

**DESCRIPTION**

FIG. 1 is a front, top, right-side perspective view of a battery for headlamp, showing the new design;  
FIG. 2 is a front elevational view thereof;  
FIG. 3 is a rear view elevational thereof;  
FIG. 4 is a left-side elevational view thereof;  
FIG. 5 is a right-side elevational view thereof;  
FIG. 6 is a top plan view thereof;  
FIG. 7 is a bottom plan view thereof; and,  
FIG. 8 is a rear, top, right-side perspective view thereof.  
The broken lines depict parts of the battery for headlamp that form no part of the claimed design.

**1 Claim, 7 Drawing Sheets**

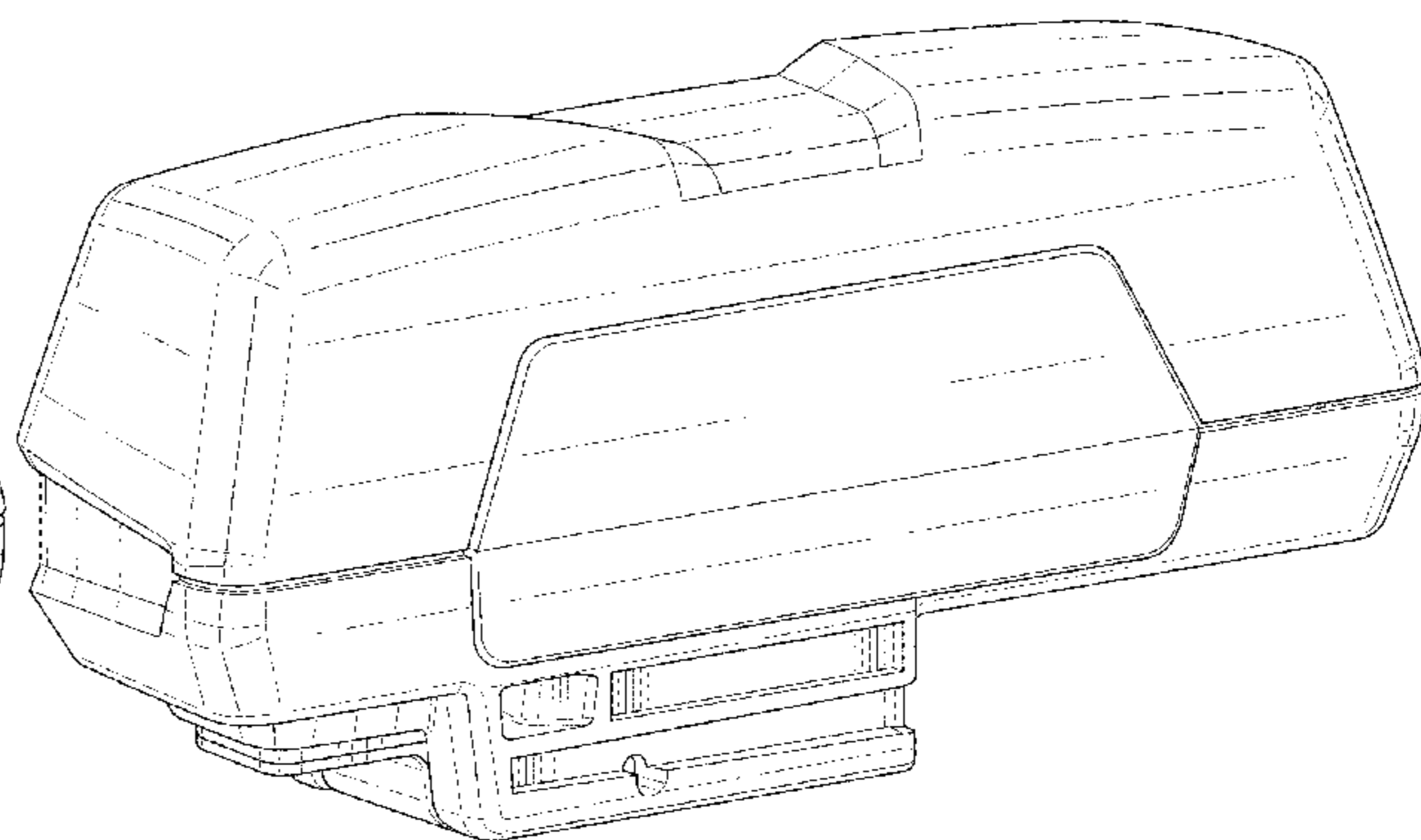
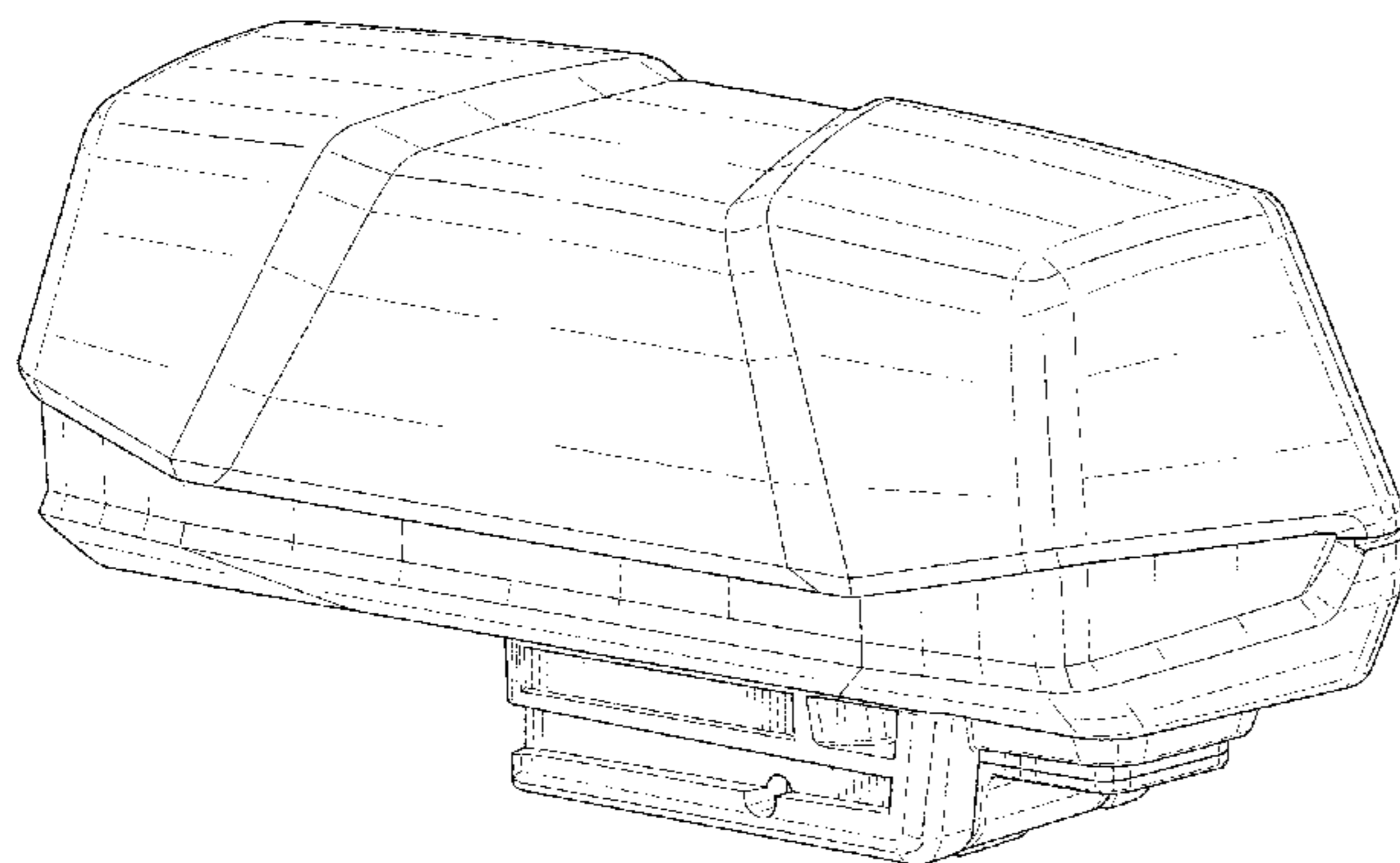

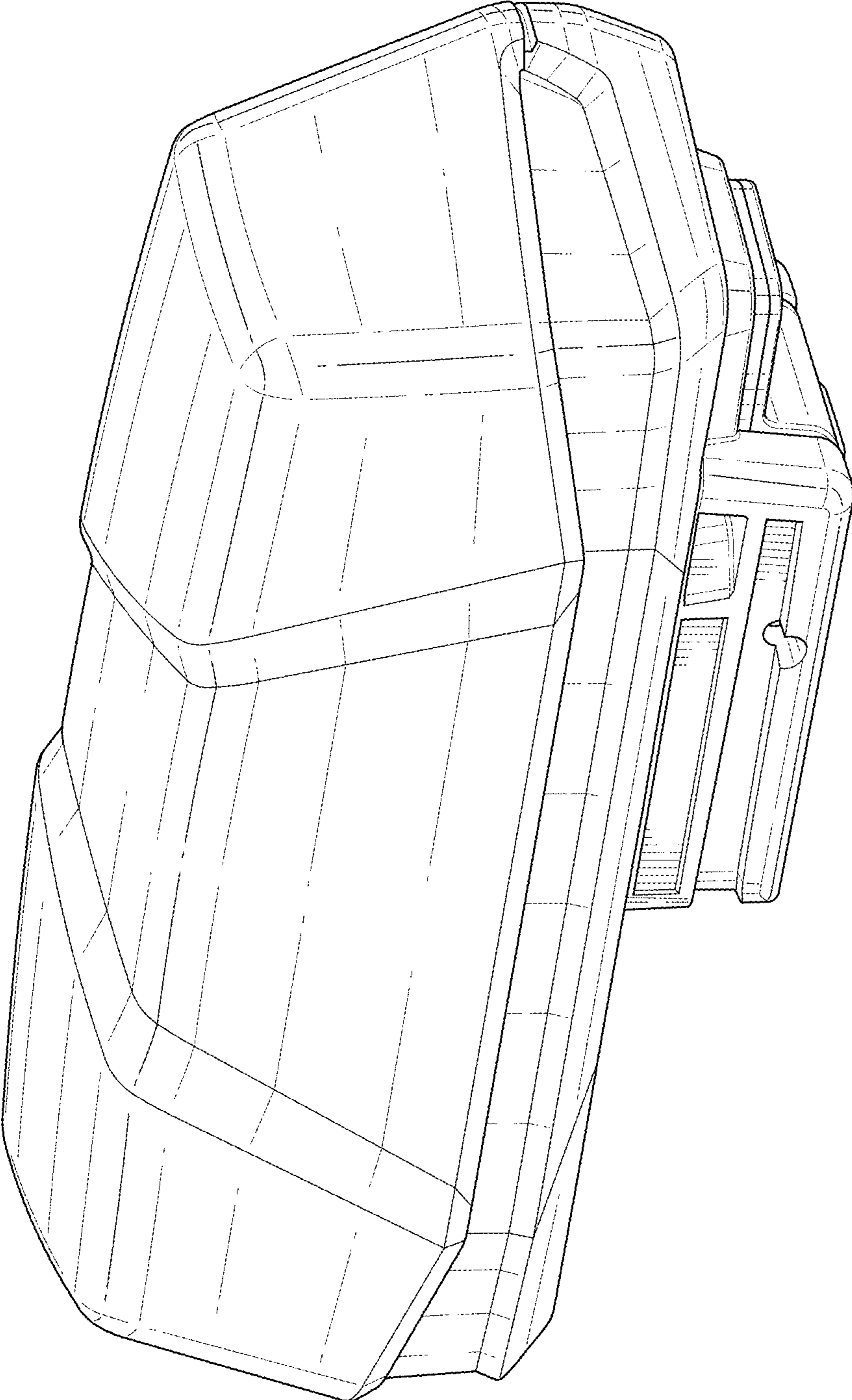

FIG. 1

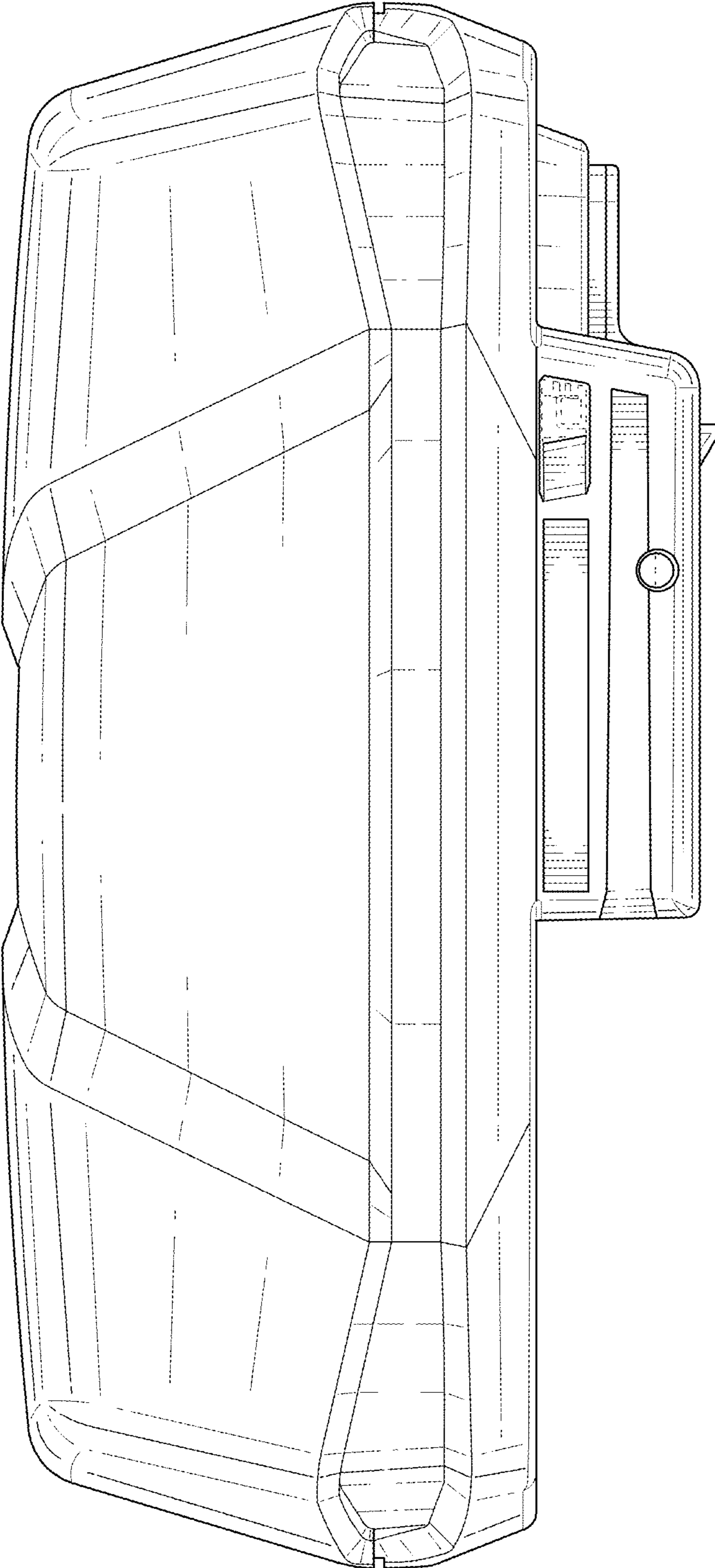

FIG. 2

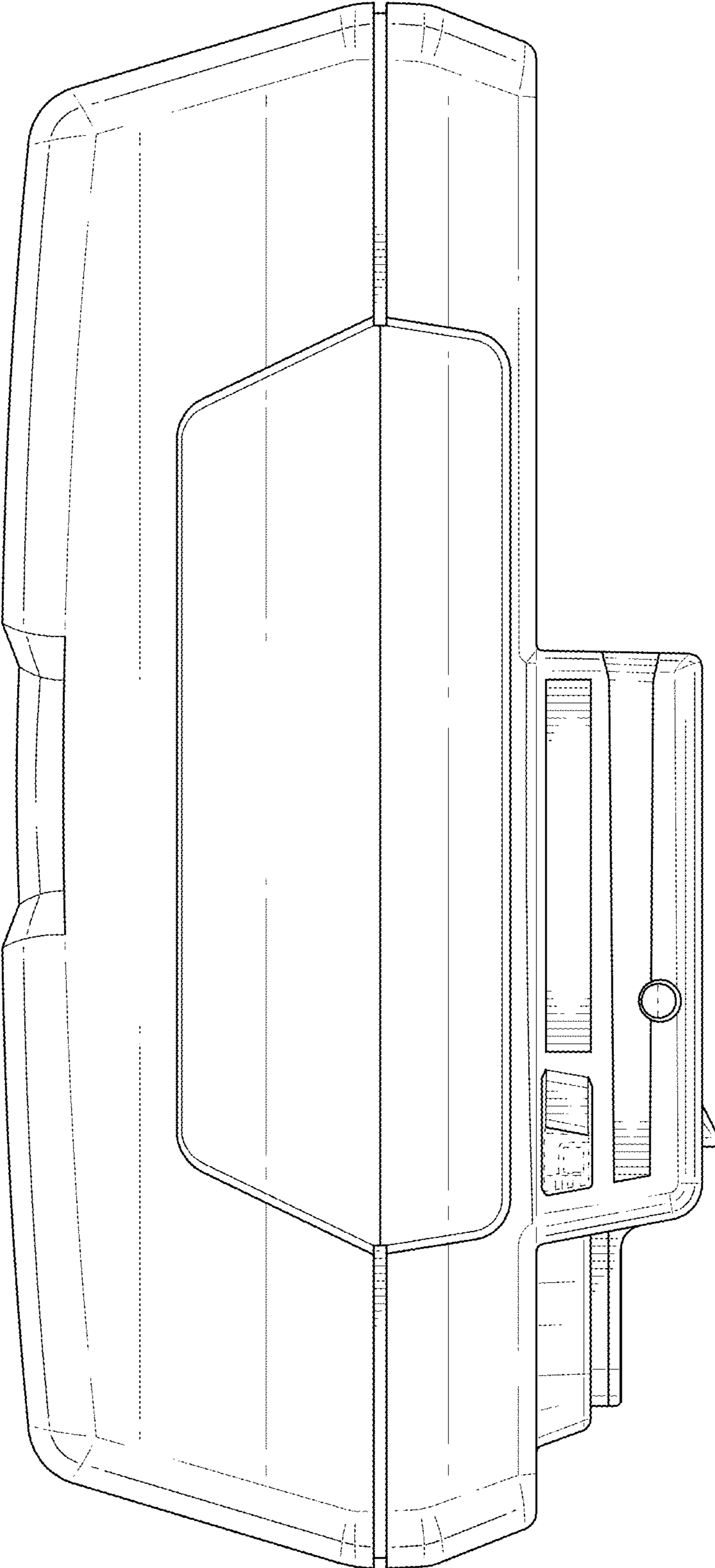

FIG. 3

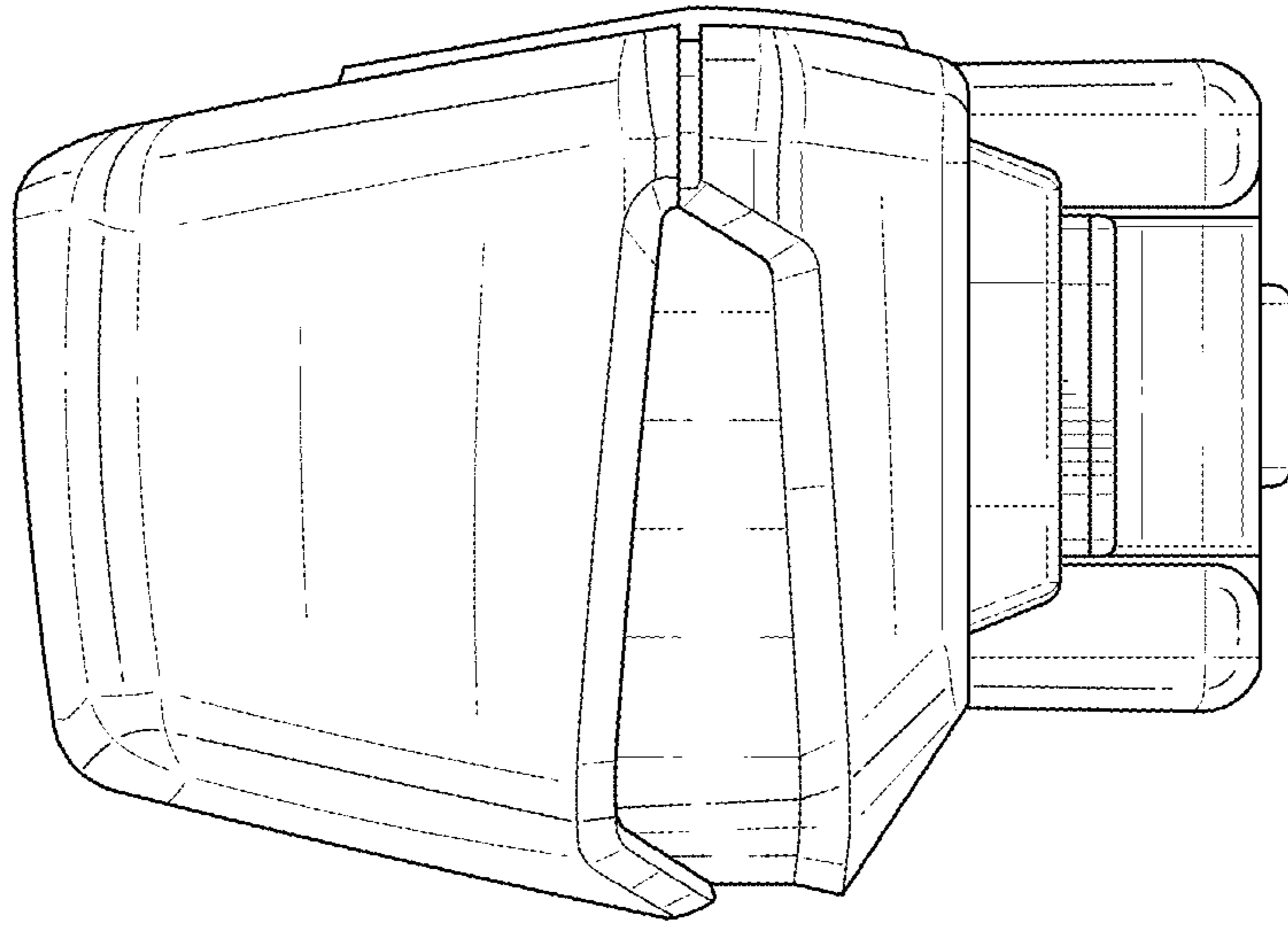

FIG. 5

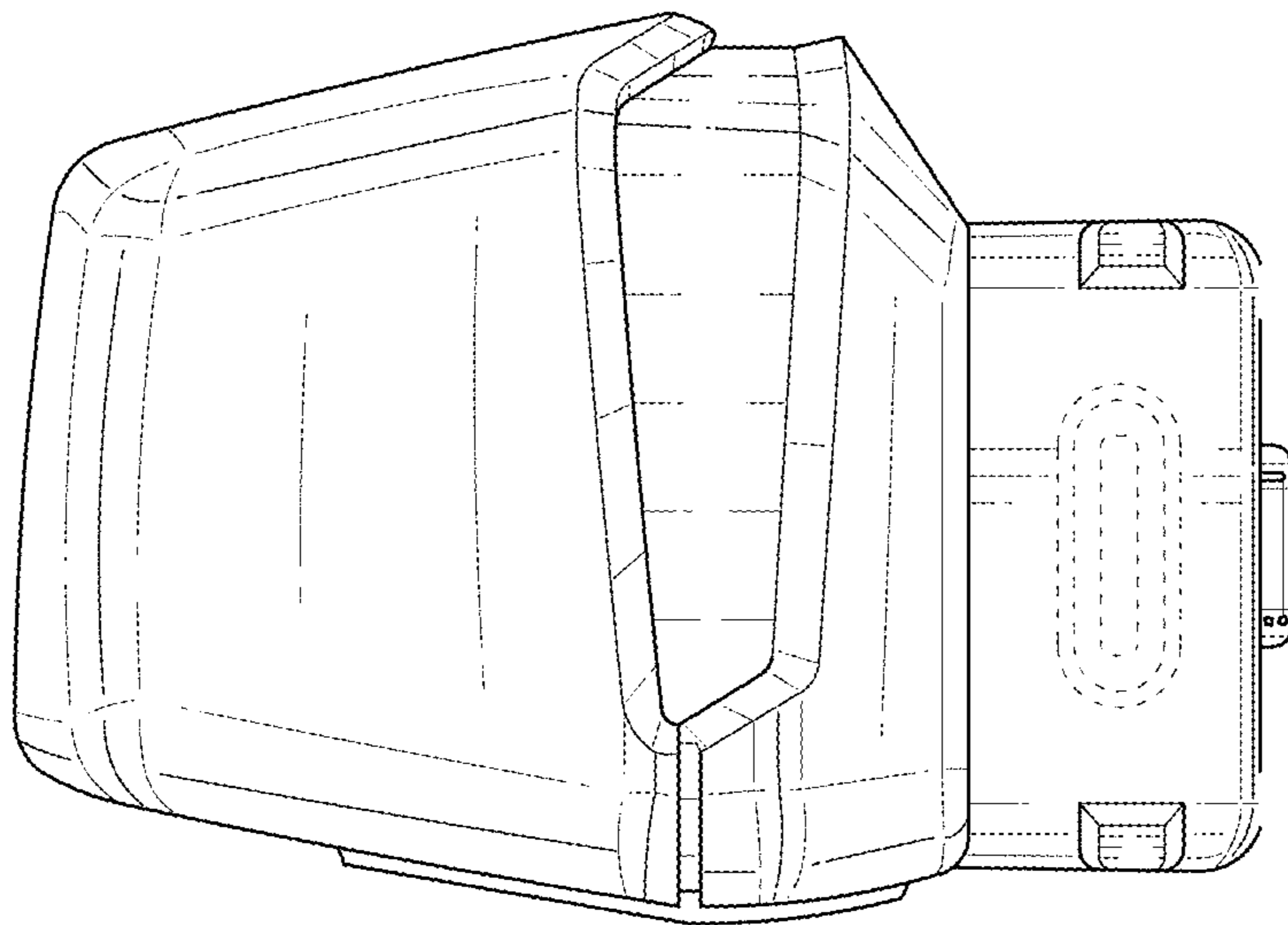

FIG. 4

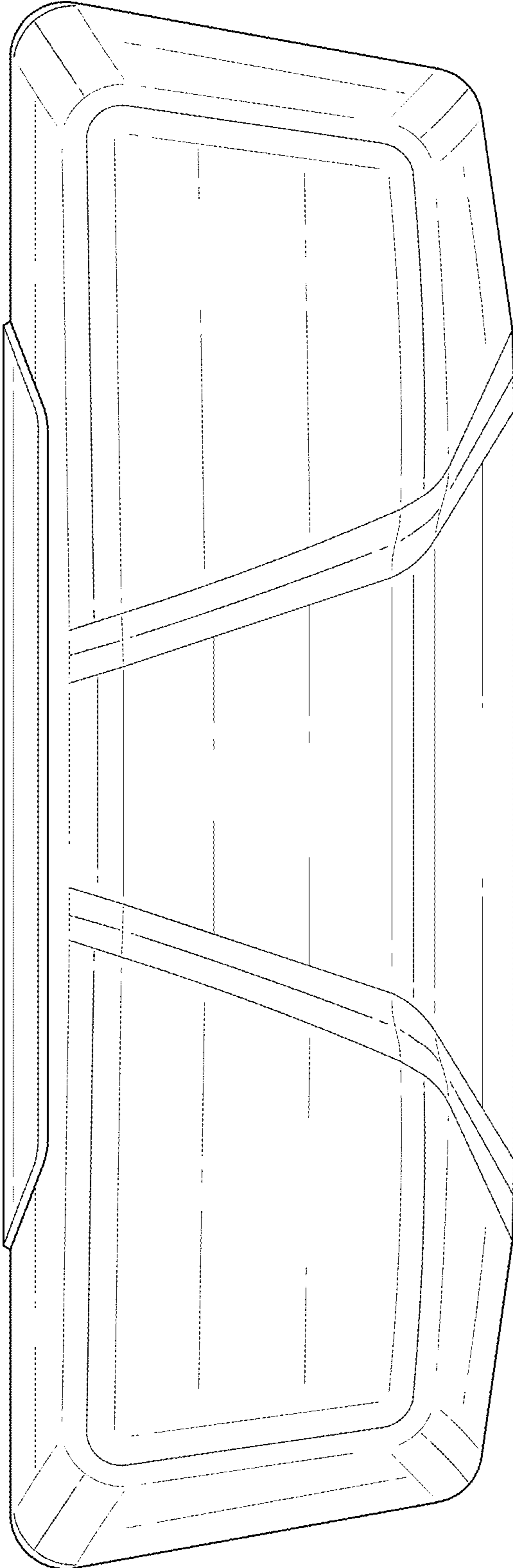

FIG. 6

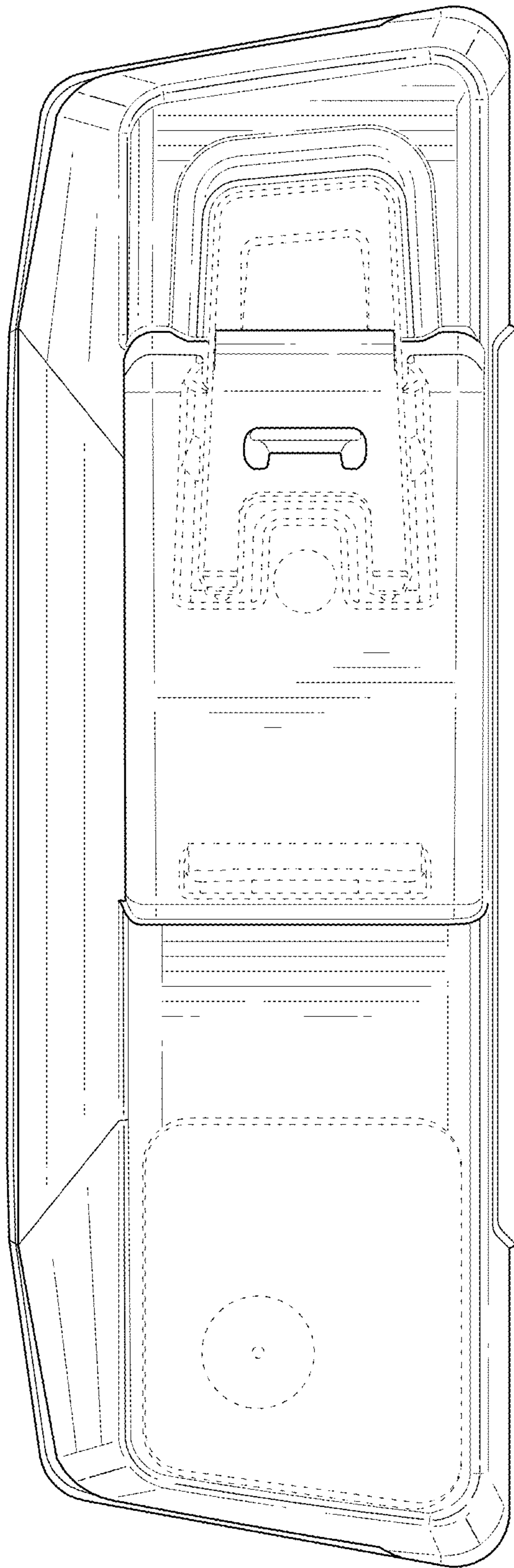

FIG. 7

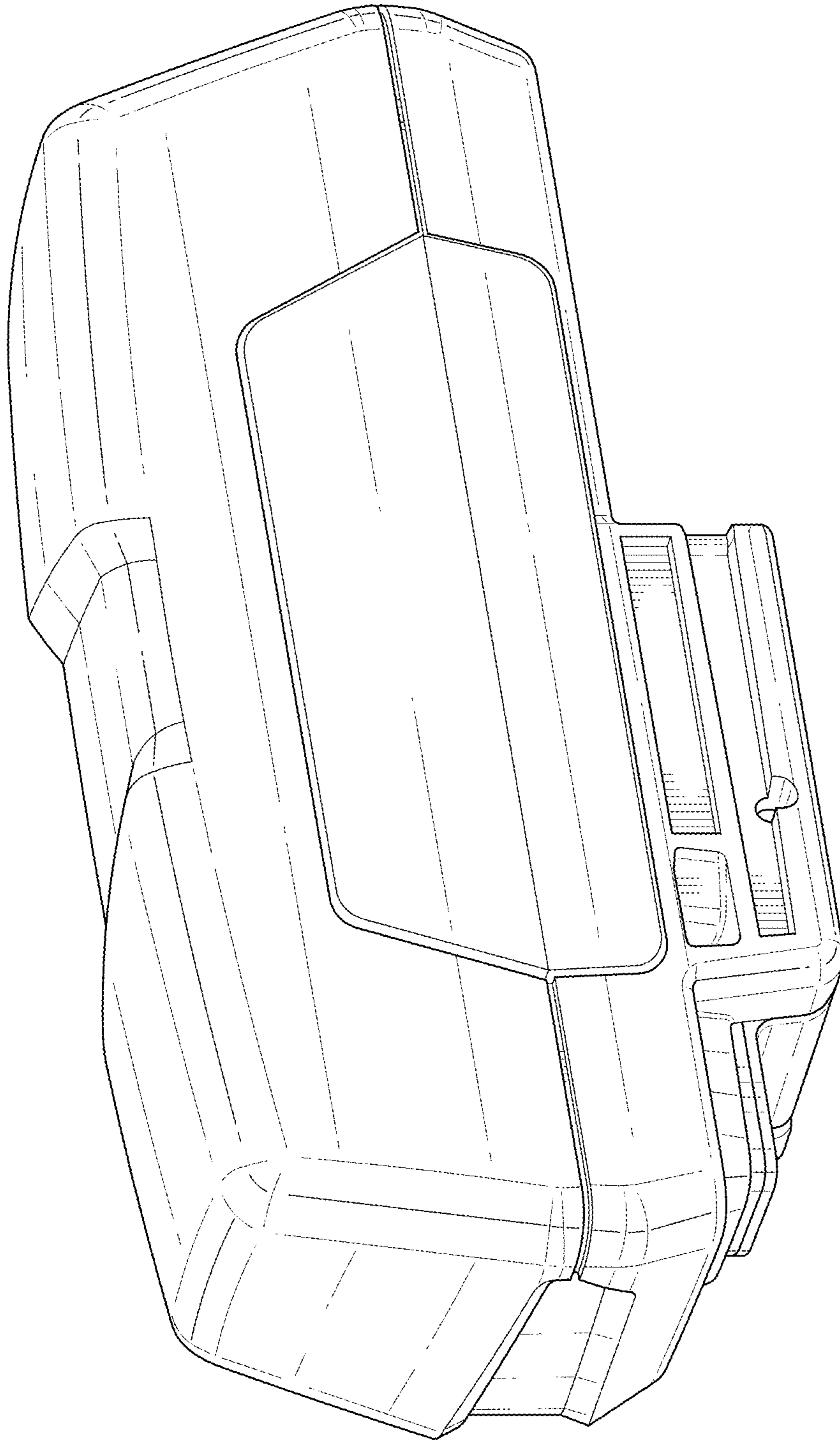

FIG. 8