



US00D987481S

(12) **United States Design Patent** (10) **Patent No.:** **US D987,481 S**  
**Matsumoto et al.** (45) **Date of Patent:** **\*\* May 30, 2023**

(54) **MOTOR VEHICLE AND/OR TOY REPLICA THEREOF**

(71) Applicants: **TOYOTA JIDOSHA KABUSHIKI KAISHA**, Toyota (JP); **SUBARU CORPORATION**, Shibuya-ku (JP)

(72) Inventors: **Tomonori Matsumoto**, Irvine, CA (US); **Koichi Matsumoto**, Toyota (JP); **Kosuke Kubo**, Okazaki (JP); **Atsushi Kochi**, Ota (JP); **Kazuki Aiba**, Ota (JP); **Kohei Kobayashi**, Kumagaya (JP)

(73) Assignees: **TOYOTA JIDOSHA KABUSHIKI KAISHA**, Toyota (JP); **SUBARU CORPORATION**, Shibuya-ku (JP)

(\*\*) Term: **15 Years**

(21) Appl. No.: **29/834,651**

(22) Filed: **Apr. 13, 2022**

**Related U.S. Application Data**

(62) Division of application No. 29/732,353, filed on Apr. 23, 2020, now Pat. No. Des. 961,454.

(30) **Foreign Application Priority Data**

Oct. 25, 2019 (JP) ..... 2019-023765

(51) **LOC (14) Cl.** ..... **12-08**

(52) **U.S. Cl.**  
USPC ..... **D12/92**

(58) **Field of Classification Search**  
USPC .... D12/86, 90-92, 164; D21/424, 433, 434, D21/533, 534, 535; 296/181.1-181.5, 296/183.1  
CPC ..... B62D 25/00; B62D 25/06; B62D 33/00; B62D 35/00

See application file for complete search history.

(56) **References Cited**

U.S. PATENT DOCUMENTS

D687,348	S	*	8/2013	Nurnberger	.....	D12/92
D693,274	S	*	11/2013	Tamatani	.....	D12/92
D704,102	S	*	5/2014	Nurnberger	.....	D12/92
D715,195	S	*	10/2014	Tomatsu	.....	D12/92
D716,699	S	*	11/2014	Sakae	.....	D12/92
D716,700	S	*	11/2014	Matsumoto	.....	D12/92
D717,211	S	*	11/2014	Stephenson	.....	D12/92
D719,065	S	*	12/2014	Sakae	.....	D12/92
D743,845	S	*	11/2015	Hirai	.....	D12/92
D758,251	S	*	6/2016	Jelec	.....	D12/92

(Continued)

OTHER PUBLICATIONS

netcarshow.com, Toyota Lexus RC F (2020), <[https://www.netcarshow.com/lexus/2020-rc\\_f](https://www.netcarshow.com/lexus/2020-rc_f)>, available as early as Sep. 4, 2019.

(Continued)

*Primary Examiner* — Melody N Brown

(74) *Attorney, Agent, or Firm* — Saidman DesignLaw Group, LLC

(57) **CLAIM**

The ornamental design for a motor vehicle and/or toy replica thereof, as shown and described.

**DESCRIPTION**

FIG. 1 is a left, front perspective view of a motor vehicle and/or toy replica thereof showing our new design; FIG. 2 is a left, rear perspective view thereof; FIG. 3 is a right, front perspective view thereof; FIG. 4 is a right, rear perspective view thereof; FIG. 5 is a left side view thereof; FIG. 6 is a right side view thereof; FIG. 7 is a rear view thereof; FIG. 8 is a front view thereof; and, FIG. 9 is a top view thereof.

**1 Claim, 9 Drawing Sheets**

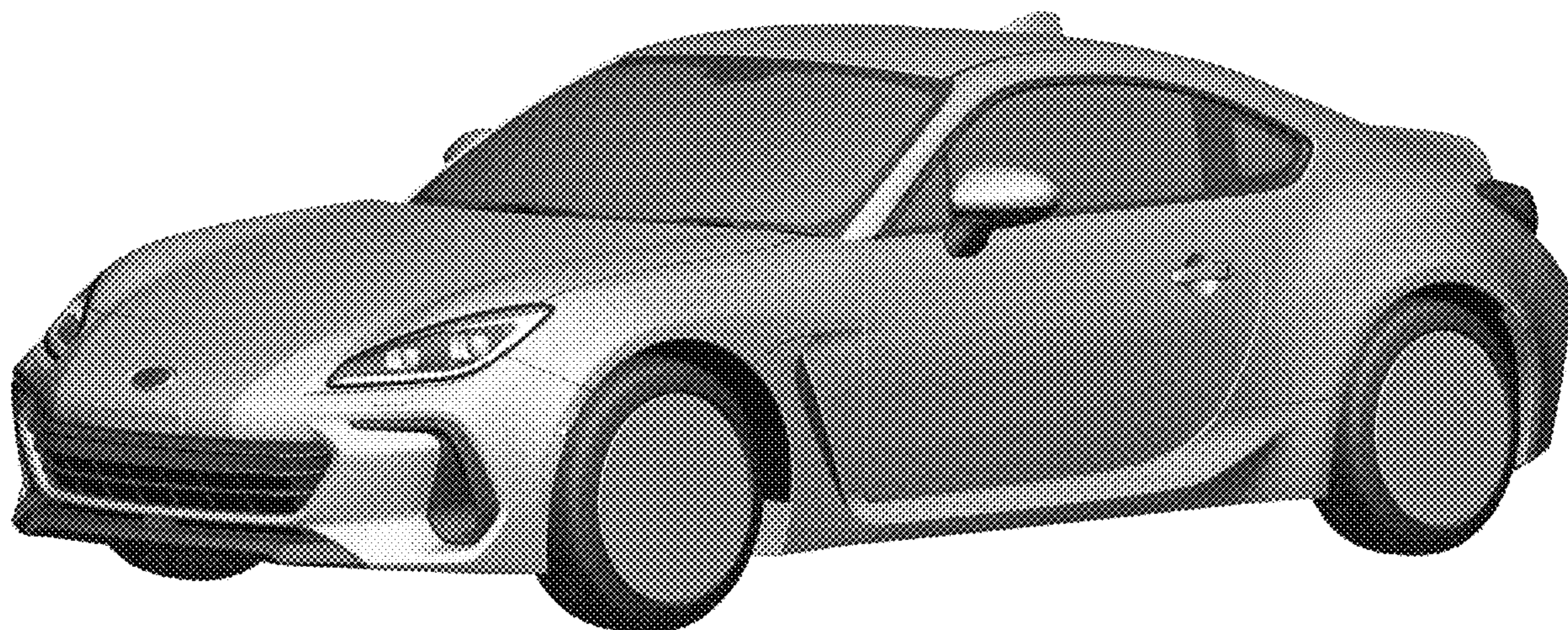

(56)

**References Cited**

U.S. PATENT DOCUMENTS

D774,950	S	*	12/2016	Holgate	.....	D12/92
D780,635	S	*	3/2017	O'Connell	.....	D12/92
D780,636	S	*	3/2017	Kahn	.....	D12/92
D781,183	S	*	3/2017	Suga	.....	D12/92
D792,286	S	*	7/2017	Nakayama	.....	D12/92
D804,997	S	*	12/2017	Hayashi	.....	D12/92
D829,609	S	*	10/2018	Niimi	.....	D12/92
D870,595	S	*	12/2019	Takei	.....	D12/92
D880,362	S	*	4/2020	Hayashi	.....	D12/92
D881,073	S	*	4/2020	Donfrancesco	.....	D12/92
D940,006	S	*	1/2022	Isogai	.....	D12/92
D940,596	S	*	1/2022	Trim	.....	D12/92
D961,454	S	*	8/2022	Matsumoto	.....	D12/92

OTHER PUBLICATIONS

netcarshow.com, Porsche Panamera (2017), <<https://www.netcarshow.com/porsche/2017-panamera/>>, available as early as Sep. 4, 2019.

\* cited by examiner

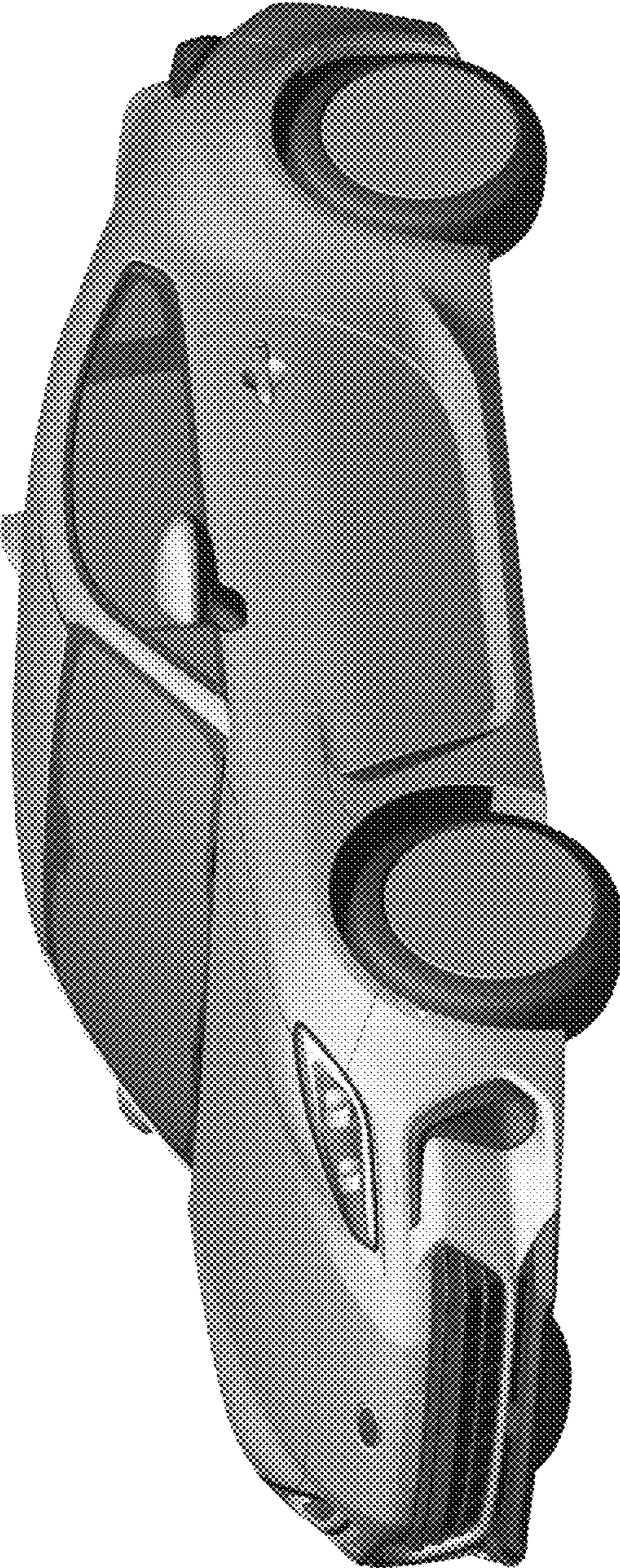

FIG. 1



FIG. 2



FIG. 3



FIG. 4

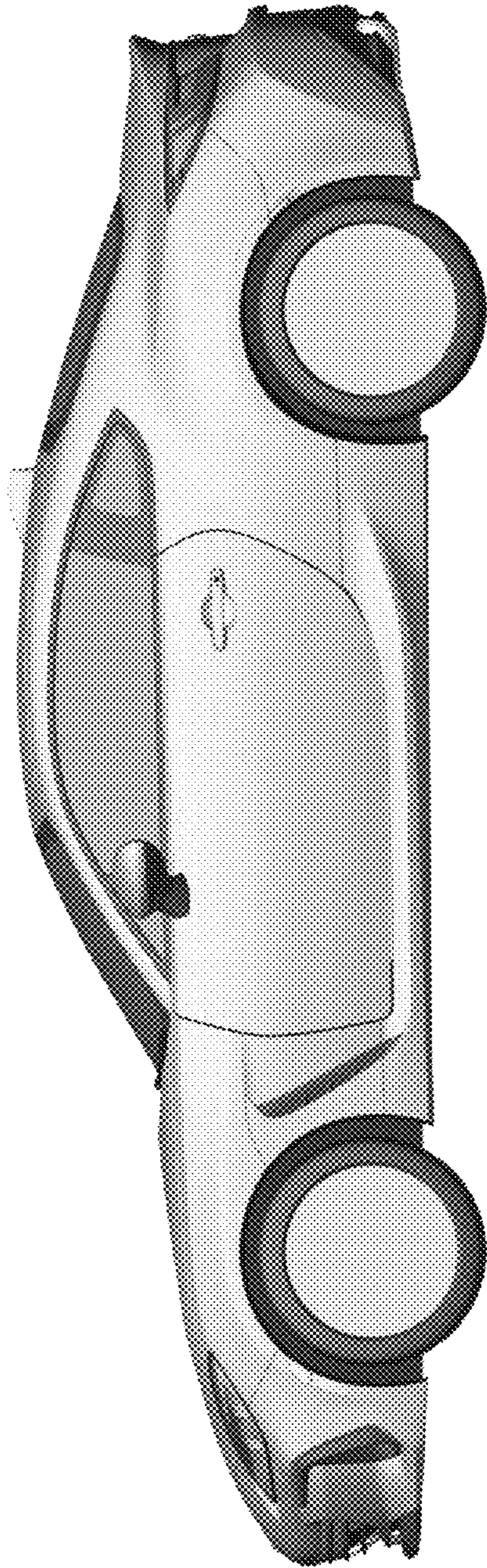

FIG. 5

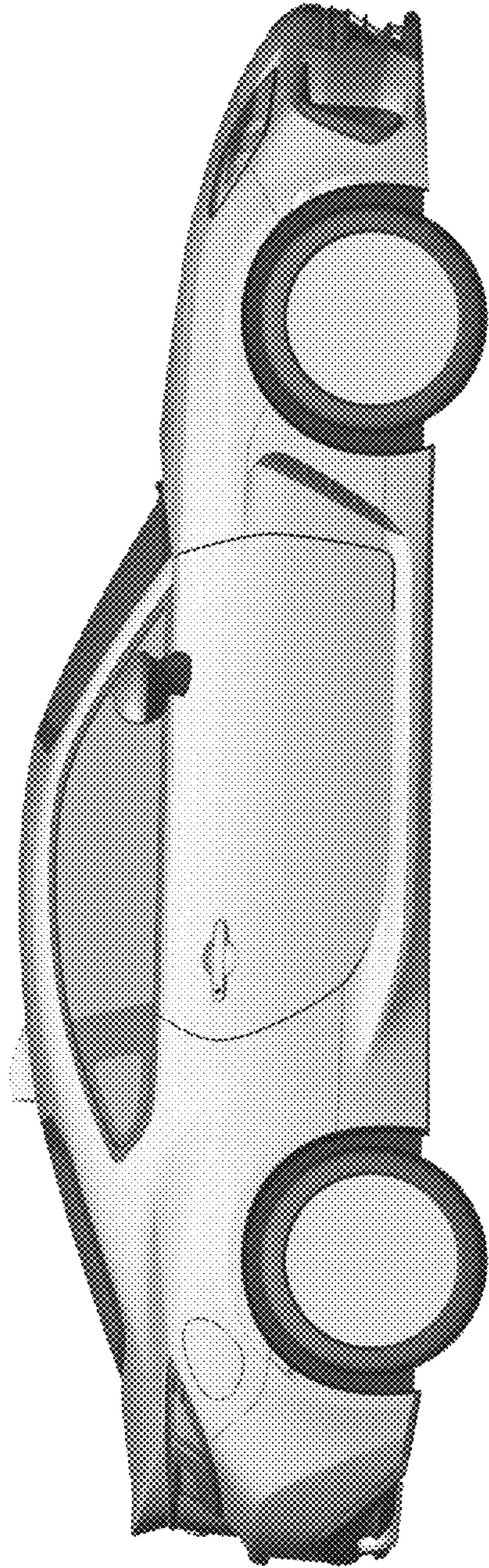

FIG. 6



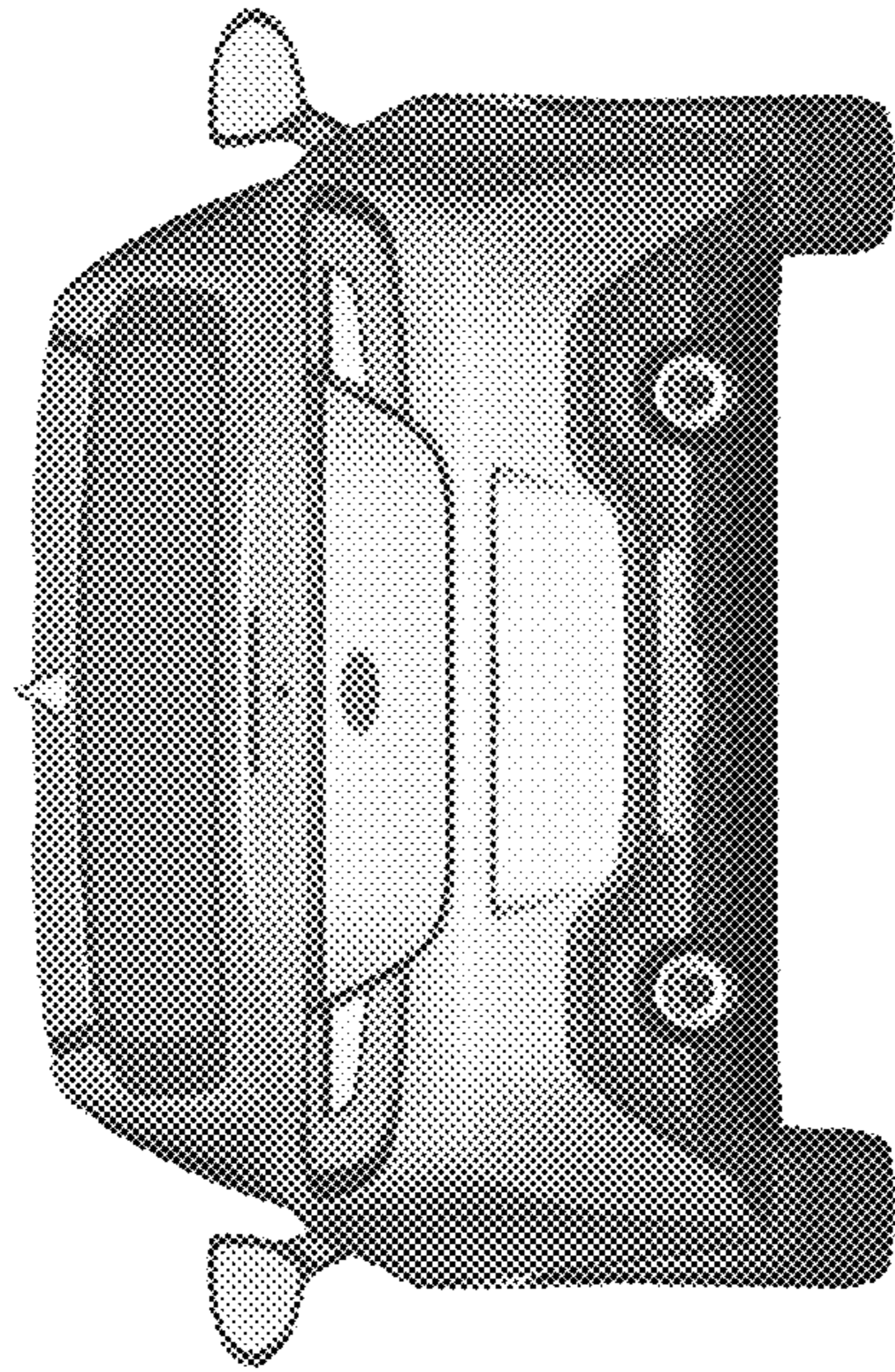

FIG. 7

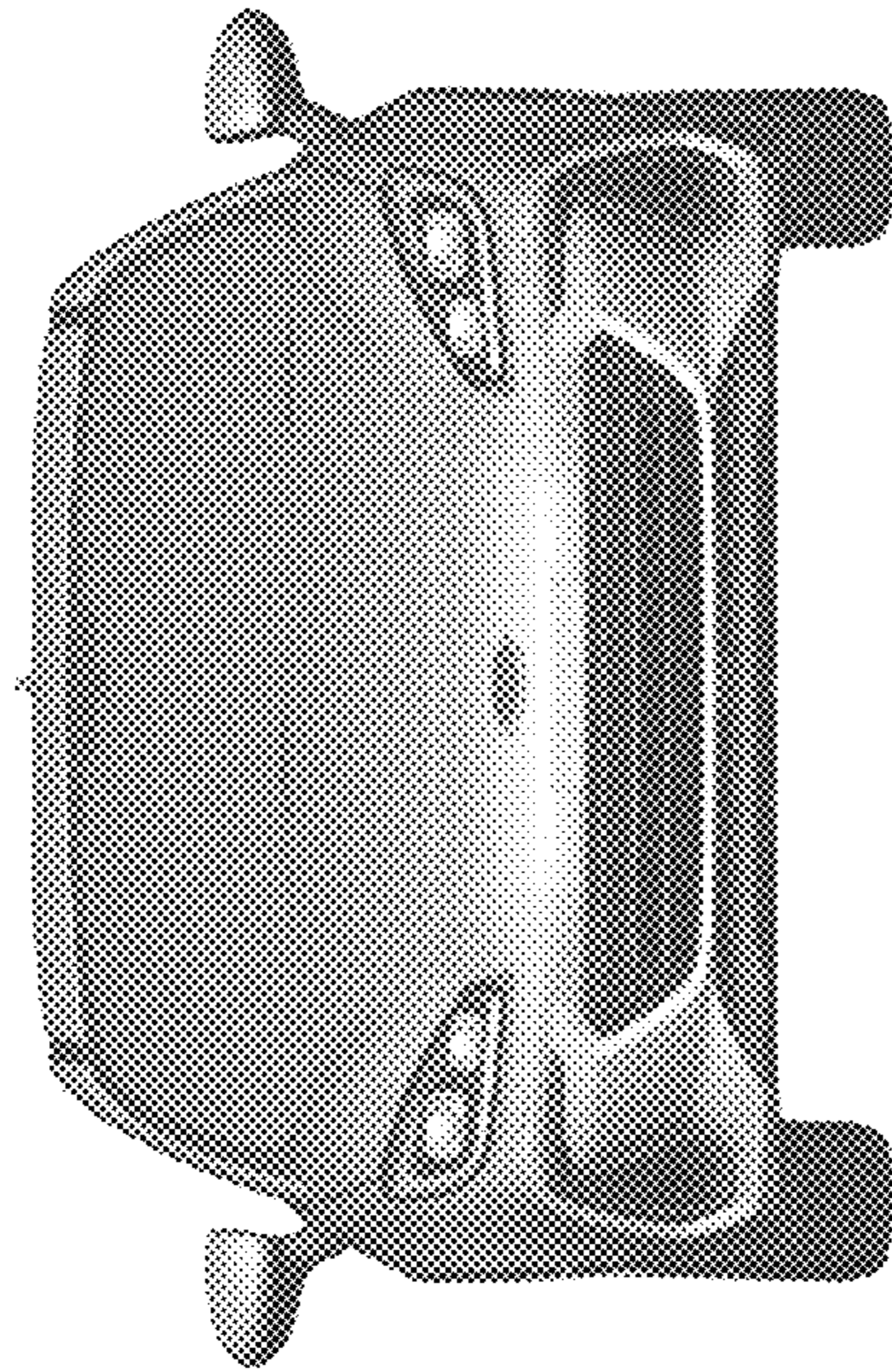

FIG. 8

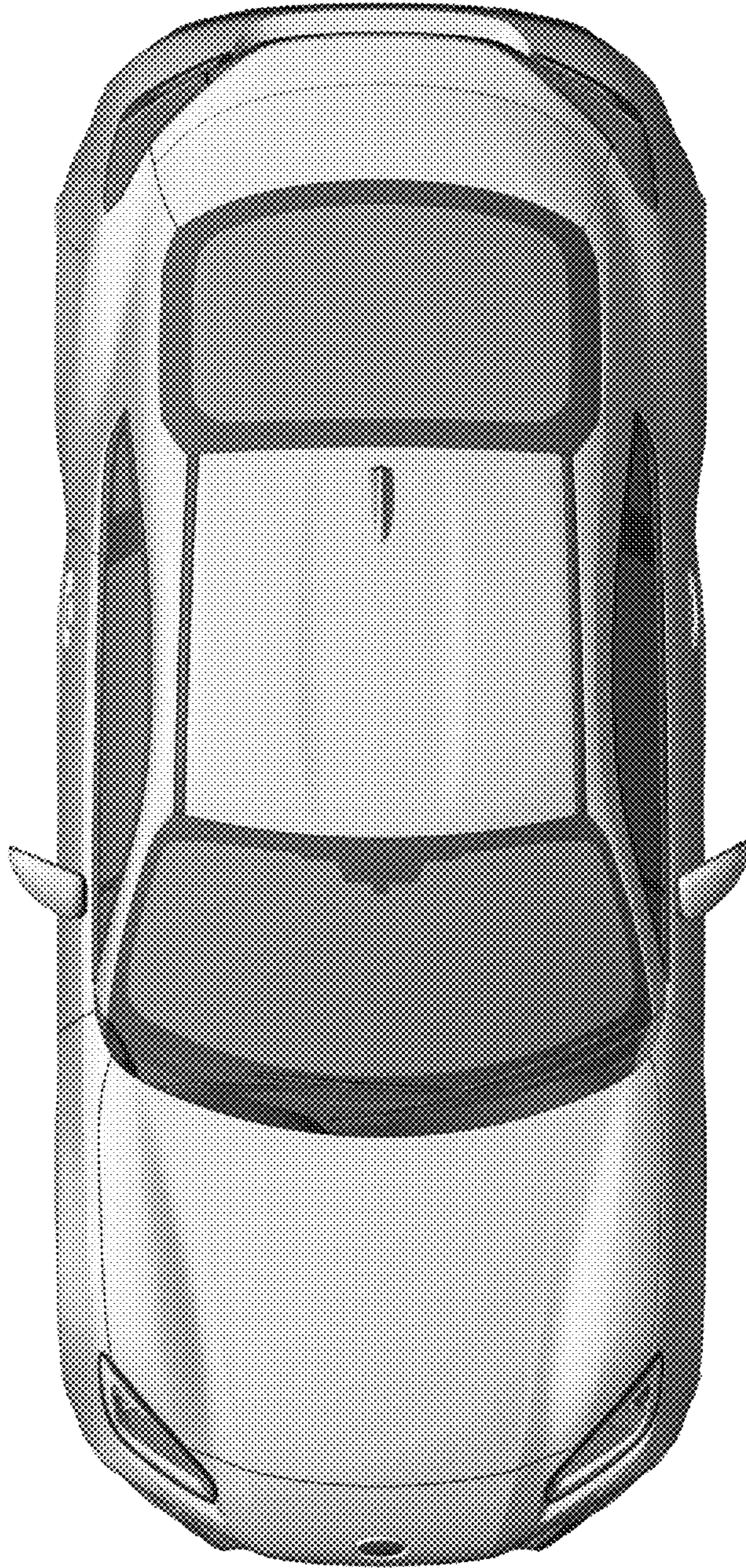

FIG. 9