



US00D987458S

(12) **United States Design Patent** (10) **Patent No.:** **US D987,458 S**
Kobayashi et al. (45) **Date of Patent:** **** May 30, 2023**

(54) **GAS ANALYZER** 2021/3129; G01N 21/8507; G01N 2201/0691; G01N 33/0037;

(71) Applicant: **YOKOGAWA ELECTRIC CORPORATION**, Musashino (JP)

(Continued)

(72) Inventors: **Jun Kobayashi**, Musashino (JP); **Norihiko Tadata**, Musashino (JP)

(56)

References Cited

(73) Assignee: **YOKOGAWA ELECTRIC CORPORATION**, Tokyo (JP)

U.S. PATENT DOCUMENTS

D256,785 S 9/1980 Salsgiver
D330,171 S 10/1992 Wilson et al.
(Continued)

(**) Term: **15 Years**

OTHER PUBLICATIONS

(21) Appl. No.: **29/852,640**

(22) Filed: **Sep. 8, 2022**

Honeywell MicroClip 4-Gas https://www.industrialsafetyproducts.com/honeywell-mcxl-xwhm-y-na-microclip-4-gas-lel-o2-co-h2s/?gclid=EAlalQobChM15ujkuc2Z-QIVhu6zCh2mzgxoEAQYBSABEgKNrFD_BwE 2020 (Year: 2020).
(Continued)

Related U.S. Application Data

(62) Division of application No. 35/512,284, filed on Jan. 25, 2021 (U.S. filing date under 35 U.S.C. 384), and
(Continued)

Primary Examiner — George D. Kirschbaum
(74) *Attorney, Agent, or Firm* — Saidman DesignLaw Group, LLC

(51) **LOC (14) Cl.** **10-04**

(52) **U.S. Cl.**
USPC **D10/81**

(57)

CLAIM

(58) **Field of Classification Search**
USPC D10/96, 81, 53, 46, 106.2
CPC G01N 21/3504; G01N 21/39; G01N 21/37;
G01N 2021/399; G01N 21/61; G01N 21/031; G01N 2201/0612; G01N 2021/1704; G01N 21/31; G01N 33/497; G01N 21/05; G01N 21/3518; G01N 27/16; G01N 7/04; G01N 33/0006; G01N 1/24; G01N 21/33; G01N 27/185; G01N 27/74; G01N 2021/1748; G01N 21/27; G01N 21/274; G01N 21/716; G01N 33/15; G01N 33/0011; G01N 21/1702; G01N 2201/06113; G01N 33/0027; G01N 2021/8578; G01N 21/314; G01N 21/15; G01N 33/0009; G01N 1/2247; G01N 21/3103; G01N 29/024; G01N 33/0016; G01N 33/004; G01N 1/2252; G01N 2021/151; G01N 2291/021; G01N 27/404; G01N 33/0004; G01N

The ornamental design for a gas analyzer, as shown and described.

DESCRIPTION

FIG. 1 is a perspective view of a gas analyzer showing our new design;
FIG. 2 is a front view thereof;
FIG. 3 is a rear view thereof;
FIG. 4 is a left side view thereof;
FIG. 5 is a right side view thereof;
FIG. 6 is a top view thereof; and,
FIG. 7 is a bottom view thereof.
The broken lines depict portions of the gas analyzer which form no part of the claimed design.
The dot-dash broken lines illustrate boundaries which form no part of the claimed design.

1 Claim, 7 Drawing Sheets

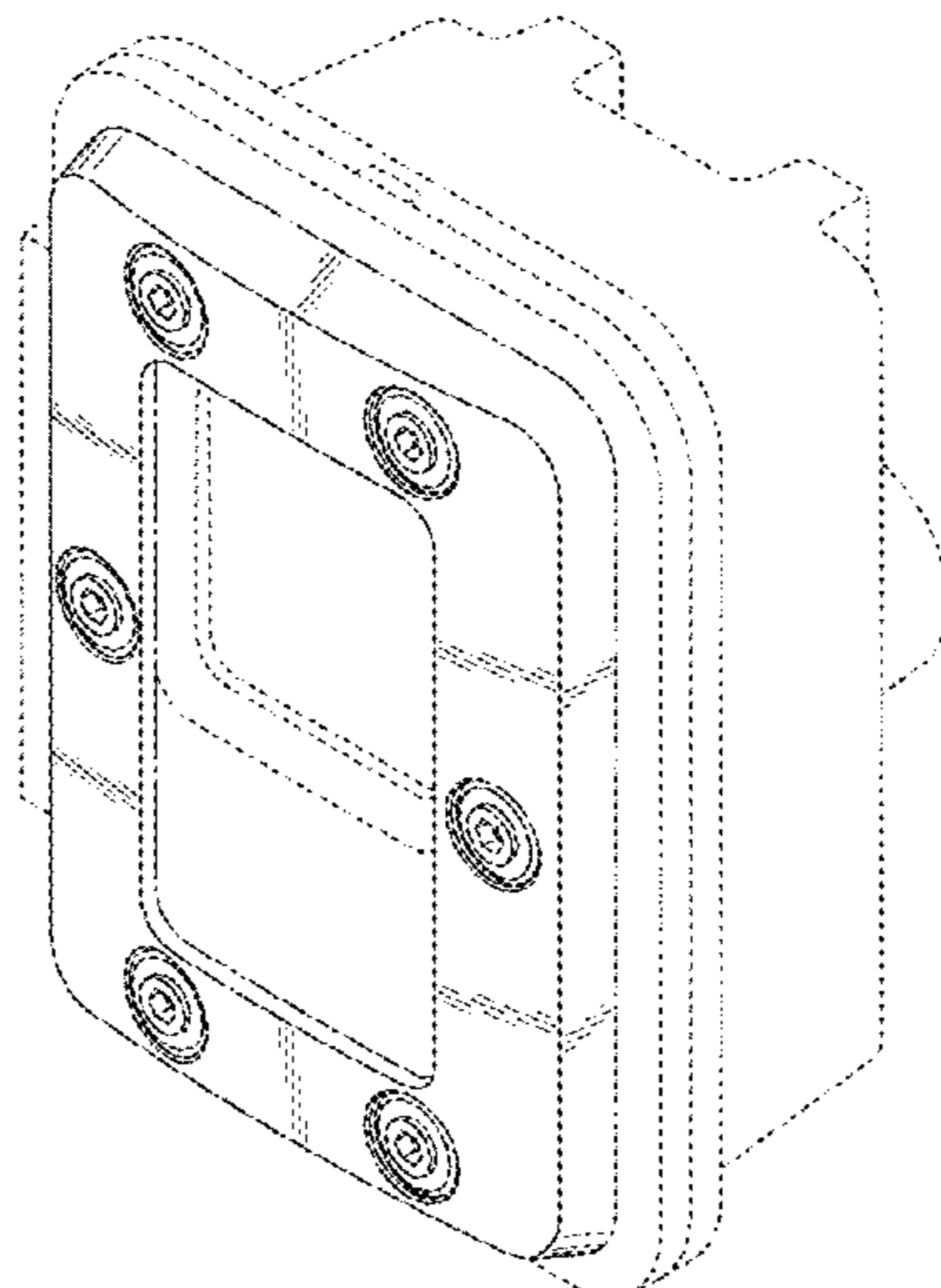

Related U.S. Application Data

having an international filing date of Jan. 25, 2021, now Pat. No. Des. 974,203.

(58) **Field of Classification Search**

CPC G01N 2030/025; G01N 27/626; G01N 29/2425; G01N 30/722; G01N 33/0014; G01N 21/85; G01N 33/0031; G01N 1/34; G01N 2001/4016; G01N 21/8483; G01N 2201/023; G01N 30/6095; G01N 33/0032; G01N 33/0047; G01N 2021/3137; G01N 21/276; G01N 21/359; G01N 21/534; G01N 2201/062; G01N 27/18; G01N 29/036; G01N 33/4925; G01N 1/2258; G01N 2021/3166; G01N 2021/8521; G01N 21/0303; G01N 21/59; G01N 21/783; G01N 2201/0668; G01N 31/005; G01N 33/0029; G01N 33/0062; G01N 33/0073; G01N 33/2823; G01N 2021/317; G01N 2021/3513; G01N 21/0332; G01N 21/255; G01N 2201/0231; G01N 2291/0215; G01N 33/0026; G01N 33/0042; G01N 33/007; G01N 2021/3174; G01N 2021/3595; G01N 2030/8854; G01N 21/3151; G01N 21/766; G01N 2201/0245; G01N 2201/0633; G01N 2201/121; G01N 2201/1215; G01N 2291/02809; G01N 25/36; G01N 27/622; G01N 29/032; G01N 29/222; G01N 30/68; G01N 30/7206; G01N 33/0018; G01N 7/00; G01N 7/10; G01N 1/2202; G01N 2001/2264; G01N 2021/3133; G01N 21/64; G01N 2201/0636; G01N 2201/1211; G01N 2291/012; G01N 27/4045; G01N 27/623; G01N 27/64; G01N 27/70; G01N 30/06; G01N 30/88; G01N 33/013; G01N 33/0022; G01N 35/00584; G01N 1/38; G01N 1/40; G01N 2001/021; G01N 2001/2267; G01N 2001/2282; G01N 2015/0693; G01N 2021/158; G01N 2021/1708; G01N 2021/3185; G01N 2021/536; G01N 2033/4975; G01N 21/03; G01N 21/09; G01N 21/17; G01N 21/69; G01N 21/84; G01N 2201/068; G01N 2201/0696; G01N 2201/08; G01N 2291/0212; G01N 25/50; G01N 27/4065; G01N 27/4175; G01N 27/419; G01N 27/62; G01N 27/66; G01N 29/022; G01N 29/30; G01N 30/02; G01N 30/461; G01N 30/64; G01N 33/2025; G01N 33/225; G01N 33/4972; G01N 35/00693; G01N 35/00712; G01N 35/00871; G01N 7/14; G01N 1/22; G01N 1/2273; G01N 1/26; G01N 2001/242; G01N 2001/387; G01N 2021/3155; G01N 2021/3531; G01N 2021/3536; G01N 2021/3545; G01N 2030/0095; G01N 21/01; G01N 21/278; G01N 21/552; G01N 21/71; G01N 21/75; G01N 22/00; G01N 2201/024; G01N 2201/126; G01N 2201/127; G01N 2291/0256; G01N 27/407; G01N 27/68; G01N 30/12; G01N 30/16; G01N 30/52; G01N 30/78; G01N 31/223; G01N 33/0024; G01N 33/0036; G01N 33/0044; G01N 33/0063; G01N

1/00; G01N 1/2205; G01N 1/4022; G01N 1/44; G01N 11/04; G01N 11/08; G01N 11/16; G01N 15/0205; G01N 15/06; G01N 2001/2238; G01N 2001/2244; G01N 2001/2261; G01N 2001/227; G01N 2001/244; G01N 2001/245; G01N 2001/4061; G01N 2021/0181; G01N 2021/0193; G01N 2021/0307; G01N 2021/0314; G01N 2021/0382; G01N 2021/0392; G01N 2021/052; G01N 2021/058; G01N 2021/178; G01N 2021/3114; G01N 2021/3159; G01N 2020/3177; G01N 2021/3196; G01N 2021/391; G01N 2021/4726; G01N 2021/4761; G01N 2021/516; G01N 2021/8466; G01N 2021/8514; G01N 2021/8585; G01N 2030/042; G01N 2030/207; G01N 2030/3007; G01N 2030/525; G01N 2030/765; G01N 2030/8411; G01N 2030/8417; G01N 2035/00108; G01N 2035/00277; G01N 2035/00346; G01N 2035/00445; G01N 21/00; G01N 21/11; G01N 21/474; G01N 21/532; G01N 21/55; G01N 21/63; G01N 21/6404; G01N 21/67; G01N 21/68; G01N 21/77; G01N 2201/0221; G01N 2201/06146; G01N 2201/06186; G01N 2201/0625; G01N 2201/0627; G01N 2201/0662; G01N 2201/069; G01N 2201/0697; G01N 2201/12; G01N 2201/1218; G01N 2201/124; G01N 2201/1247; G01N 2201/12792; G01N 2201/129; G01N 2291/0255; G01N 2291/02818; G01N 2291/02881; G01N 2291/0421; G01N 2291/0423; G01N 2291/0427; G01N 2291/101; G01N 2291/102; G01N 2291/103; G01N 2291/2695; G01N 25/14; G01N 25/18; G01N 25/28; G01N 25/54; G01N 25/56; G01N 27/06; G01N 27/12; G01N 27/128; G01N 27/4067; G01N 27/409; G01N 27/41; G01N 29/14; G01N 29/2418; G01N 29/2431; G01N 29/2462; G01N 29/326; G01N 30/04; G01N 30/24; G01N 30/30; G01N 30/465; G01N 30/70; G01N 30/72; G01N 30/7246; G01N 30/728; G01N 30/76; G01N 31/22; G01N 33/0039; G01N 33/0059; G01N 33/0098; G01N 33/241; G01N 33/4875; G01N 33/84; G01N 7/08; G01N 9/002; G01N 1/125; G01N 1/1409; G01N 1/2214; G01N 1/2226; G01N 1/405; G01N 2001/2235; G01N 2001/2255; G01N 2001/4066; G01N 2021/0106; G01N 2021/0321; G01N 2021/0346; G01N 2021/036; G01N 2021/115; G01N 2021/1793; G01N 2021/1795; G01N 2021/3107; G01N 2021/3125; G01N 2021/451; G01N 2021/8571; G01N 2030/126; G01N 2030/146; G01N 2030/303; G01N 2030/3061; G01N 2030/324; G01N 2030/385; G01N

2030/623; G01N 2030/626; G01N
 2030/862; G01N 2030/8804; G01N
 2030/8813; G01N 2030/8881; G01N
 2030/8886; G01N 2030/889; G01N
 2033/0019; G01N 2033/0068; G01N
 21/13; G01N 21/211; G01N 21/256;
 G01N 21/35; G01N 21/645; G01N 21/65;
 G01N 21/72; G01N 2201/02; G01N
 2201/0216; G01N 2201/06166; G01N
 2201/0624; G01N 2201/0631; G01N
 2201/123; G01N 2201/1245; G01N
 2201/12715; G01N 2201/1273; G01N
 2201/12769; G01N 2201/1283; G01N
 2201/1285; G01N 2201/1286; G01N
 2291/0217; G01N 2291/02836; G01N
 2333/765; G01N 2333/805; G01N
 2496/05; G01N 2496/70; G01N 25/22;
 G01N 25/48; G01N 27/123; G01N
 27/124; G01N 27/125; G01N 27/4075;
 G01N 27/4078; G01N 27/4168; G01N
 27/48; G01N 29/343; G01N 29/348;
 G01N 30/08; G01N 30/28; G01N 30/38;
 G01N 30/40; G01N 30/46; G01N 30/466;
 G01N 30/467; G01N 30/54; G01N 30/66;
 G01N 30/74; G01N 30/8603; G01N
 30/8637; G01N 31/12; G01N 31/224;
 G01N 33/005; G01N 33/0065; G01N
 33/0075; G01N 33/1886; G01N 33/2841;
 G01N 33/721; G01N 33/80; G01N 33/96;
 G01N 35/1095; G01N 35/1097; G01N
 7/18; G01K 13/02; G01K 13/024; G01K
 13/00; G01K 15/00; G01K 7/02; G01K
 7/16

(56)

References Cited

U.S. PATENT DOCUMENTS

D404,324 S	1/1999	Seager et al.	
D447,974 S	9/2001	Koyano et al.	
D457,456 S	5/2002	Holland	
D485,771 S	1/2004	Ribeiro	
D499,347 S	12/2004	Fudali et al.	
D558,622 S *	1/2008	Hilliker	D10/81
D671,851 S	12/2012	Treharne et al.	
D768,012 S *	10/2016	Kim	D10/52
D811,916 S	3/2018	Lee et al.	
D826,752 S	8/2018	Lee et al.	
D842,736 S *	3/2019	Laurino	D24/232
D862,260 S *	10/2019	Nelko	D10/81
D864,773 S *	10/2019	Zhang	D10/52
D874,302 S	2/2020	Ruttler et al.	
D876,249 S *	2/2020	Bee	D10/53
D878,228 S *	3/2020	Takano	D10/81
D894,022 S *	8/2020	Guillien	D10/53
D899,280 S *	10/2020	Takano	D10/81
D899,281 S *	10/2020	Takano	D10/81
D919,464 S *	5/2021	Takano	D10/81
D922,226 S *	6/2021	Billoet	D10/81
D931,747 S	9/2021	Bürdel et al.	
D931,749 S *	9/2021	Zhong	D10/106.5
D939,984 S	1/2022	Duan et al.	
D942,872 S *	2/2022	Zhang	D10/53
D949,033 S	4/2022	Zhu	
D957,957 S *	7/2022	Cho	D10/53
D968,988 S *	11/2022	Kaimasu	D10/81
D969,621 S *	11/2022	Zheng	D10/53
D971,764 S *	12/2022	Wännerud	D10/81

OTHER PUBLICATIONS

Basic 4 Gas Monitor <https://www.forensicsdetectors.com/products/basic-multigas-detector> (Year: 2020).

* cited by examiner

See application file for complete search history.

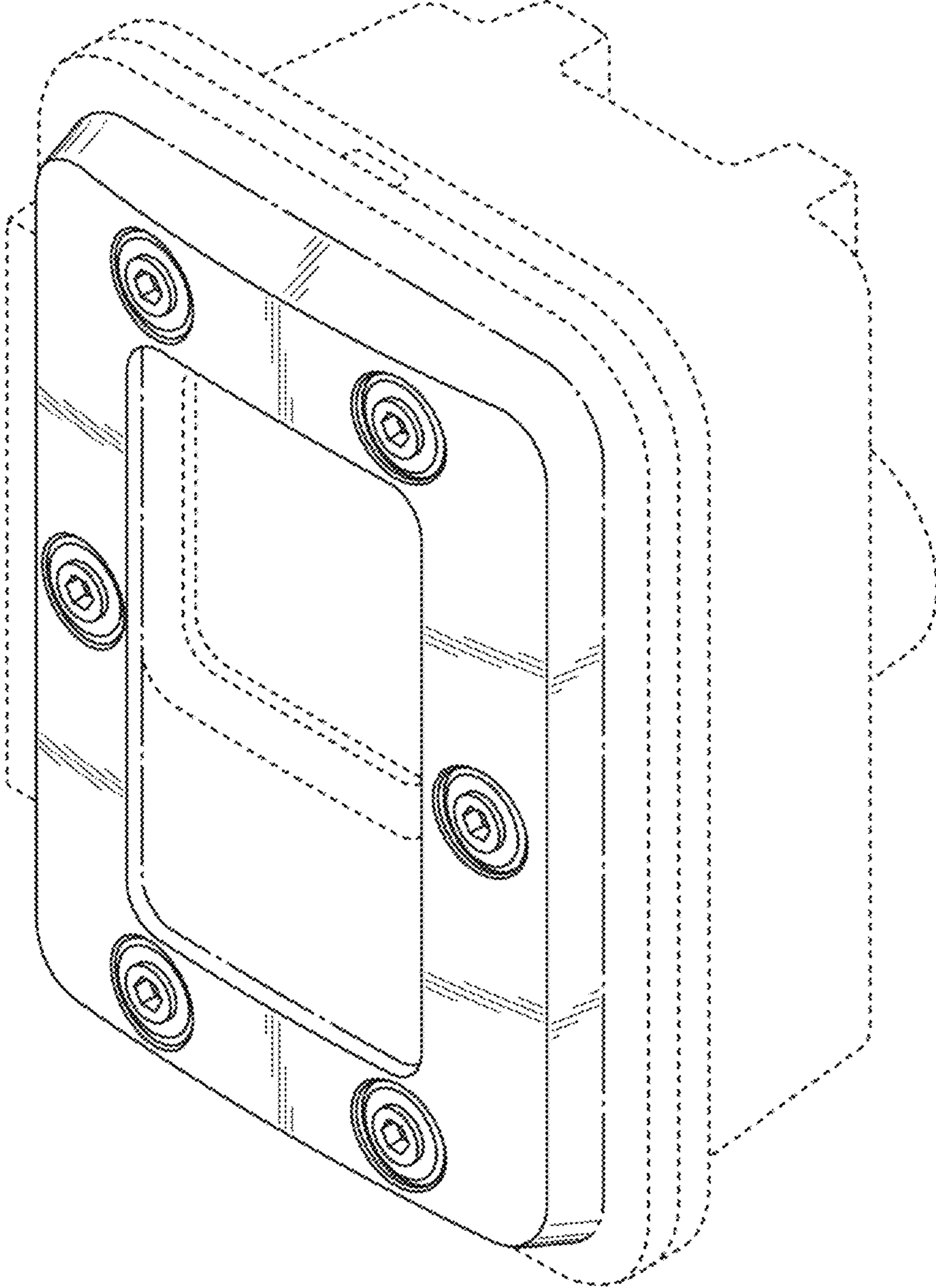

FIG. 1

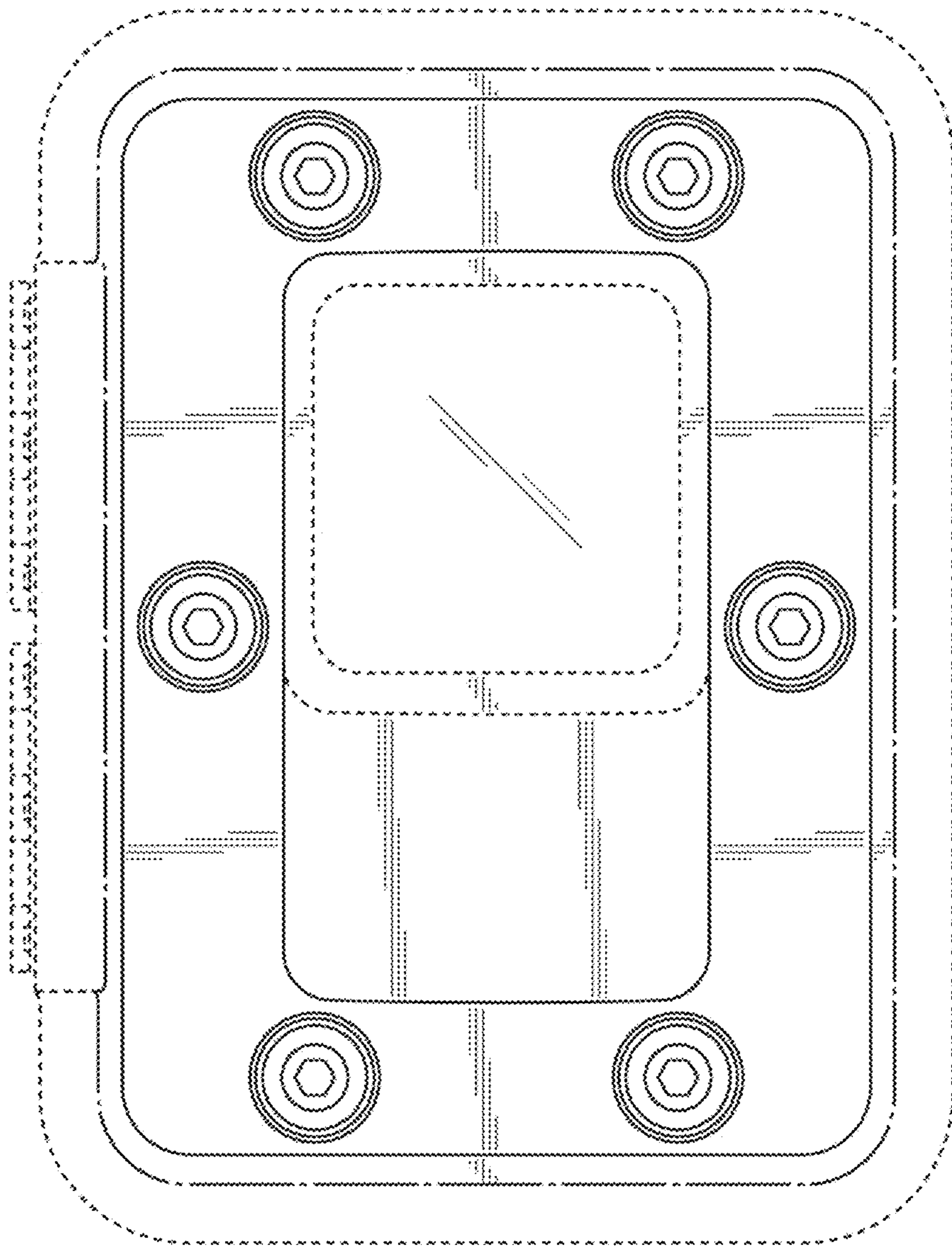

FIG. 2

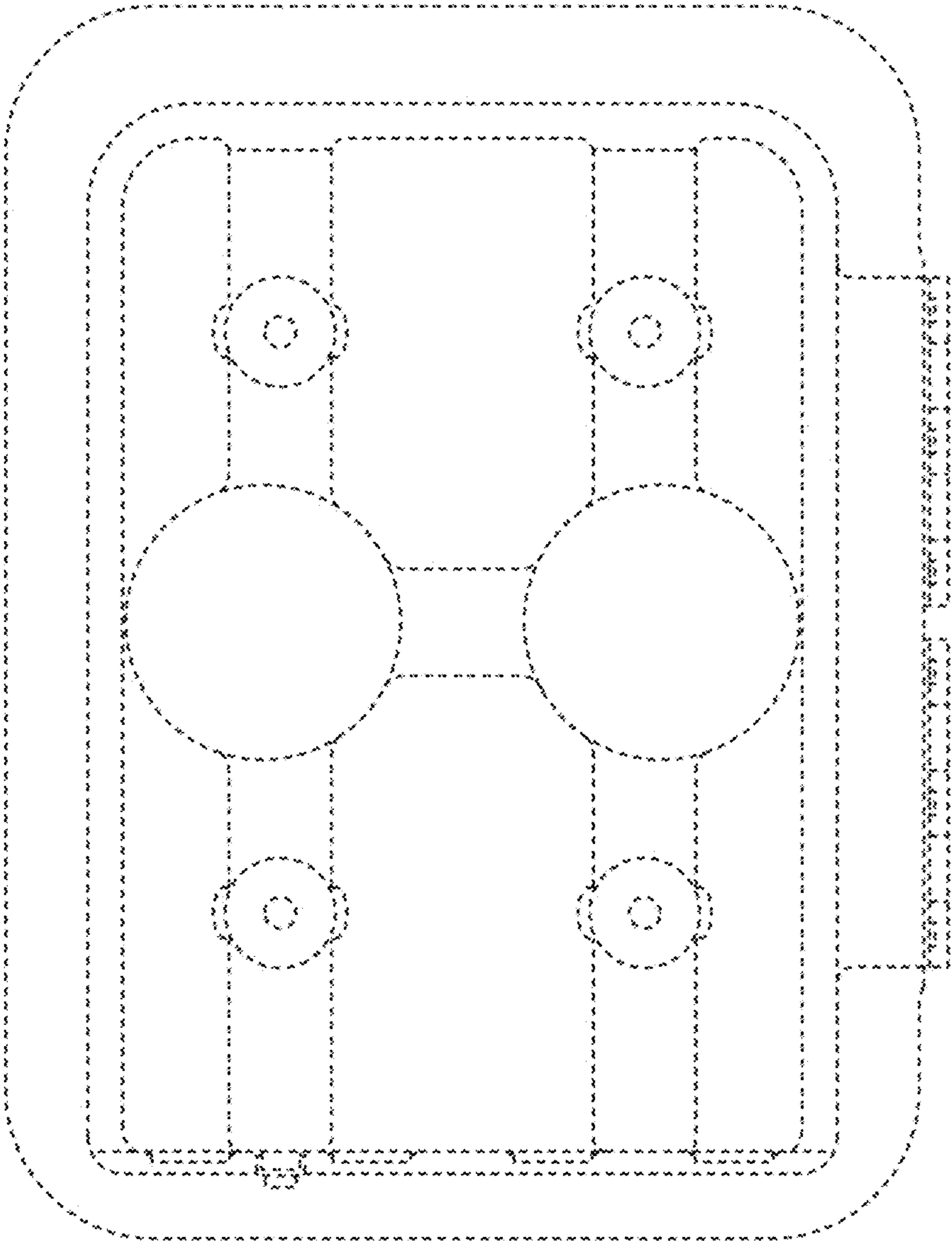

FIG. 3

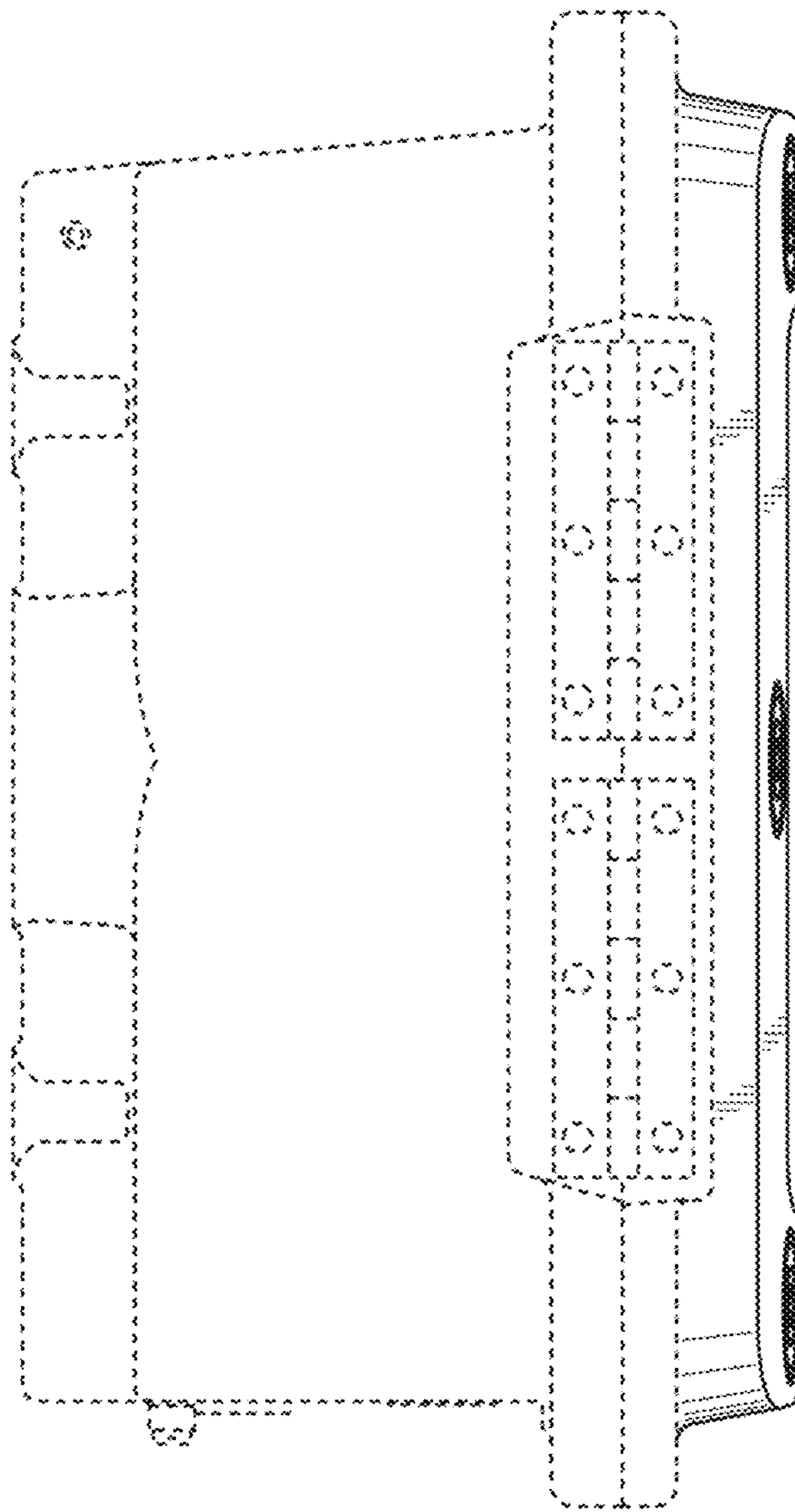

FIG. 4

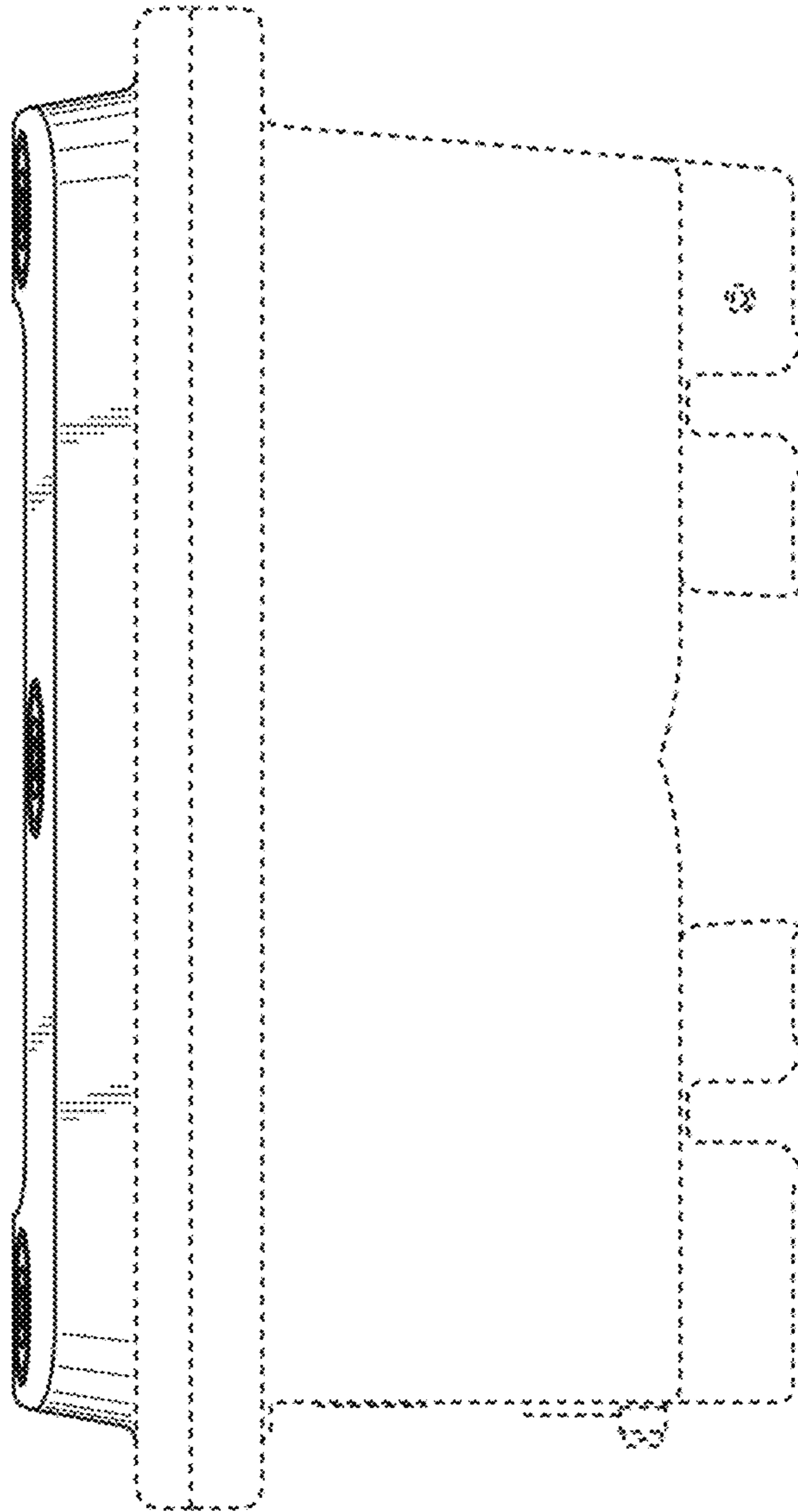

FIG. 5

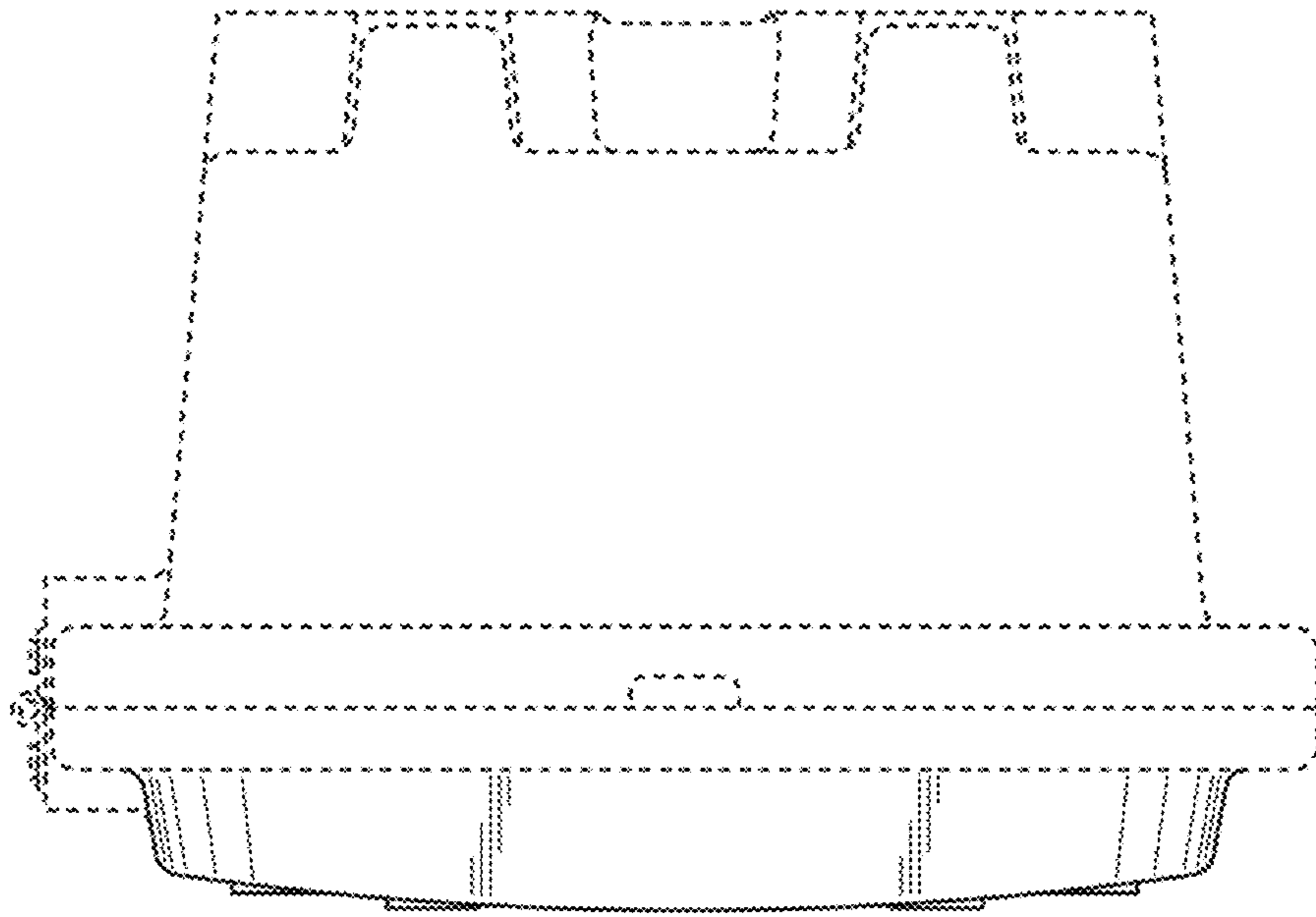

FIG. 6

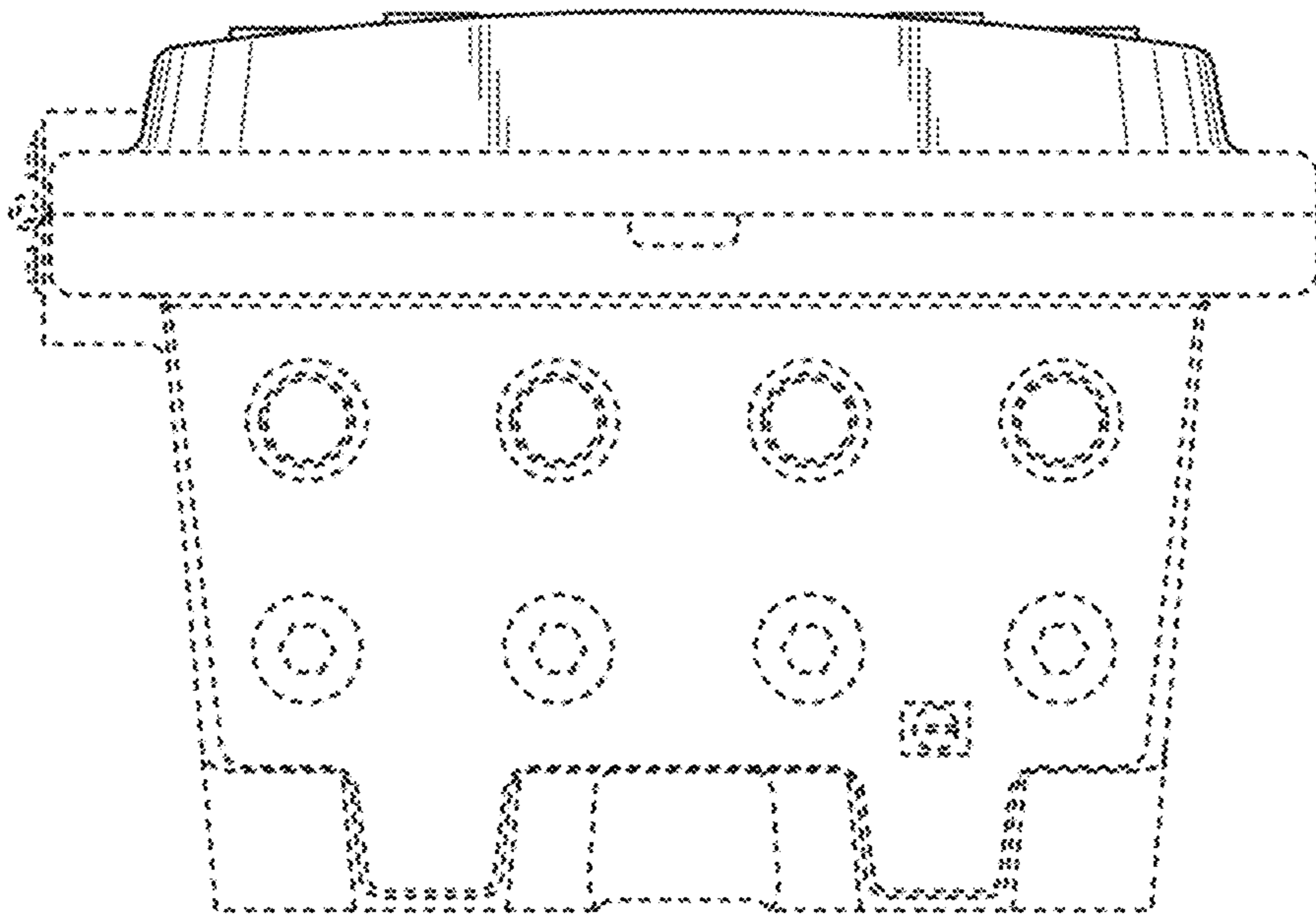

FIG. 7