



US00D987115S

(12) **United States Design Patent**  
**Chen et al.**

(10) **Patent No.:** **US D987,115 S**  
(45) **Date of Patent:** **\*\* May 23, 2023**

- (54) **PREFAB HOUSE**
- (71) Applicant: **Foshan Alpicool Technology Co., LTD.**, Foshan (CN)
- (72) Inventors: **Jingcheng Chen**, Nanning (CN);  
**Shuangyan Mei**, Foshan (CN)
- (73) Assignee: **Foshan Alpicool Technology Co., LTD.**, Foshan (CN)
- (\*\*) Term: **15 Years**
- (21) Appl. No.: **29/844,759**
- (22) Filed: **Jun. 30, 2022**
- (30) **Foreign Application Priority Data**  
Jun. 9, 2022 (CN) ..... 202230349119.5
- (51) **LOC (14) Cl.** ..... **25-03**
- (52) **U.S. Cl.**  
USPC ..... **D25/33**
- (58) **Field of Classification Search**  
USPC ..... D25/1, 3-35; D15/122; D12/102-106  
CPC ..... E04H 1/00-1277; E04H 2001/1283-1294  
See application file for complete search history.

- (56) **References Cited**  
**U.S. PATENT DOCUMENTS**  
3,905,167 A \* 9/1975 Watkins ..... E04B 1/34846  
D237,378 S \* 10/1975 Ekuan ..... D25/4  
D238,778 S \* 2/1976 Watkins ..... D25/4  
D238,943 S \* 2/1976 Curci ..... D25/33  
D261,809 S \* 11/1981 Chambers ..... D25/33  
D559,403 S \* 1/2008 Vils ..... D25/33  
D596,313 S \* 7/2009 Perrine ..... D25/1  
D650,913 S \* 12/2011 Vittori ..... D25/35  
D676,575 S \* 2/2013 Wada ..... D25/33

- D822,227 S \* 7/2018 Schmiedel ..... D25/18
- D829,925 S \* 10/2018 Labesque ..... D25/33
- D844,826 S \* 4/2019 Kwong ..... D25/18
- D862,733 S 10/2019 Kwong
- D882,115 S \* 4/2020 Stuart-Smith ..... D25/18
- D916,316 S 4/2021 Schumacher
- D932,526 S \* 10/2021 Son ..... D15/122
- D948,076 S \* 4/2022 Goetgeluk ..... D25/33
- D950,771 S \* 5/2022 Hirvesaar ..... D25/33

**OTHER PUBLICATIONS**

Walk Through Vessel the Prefabricated House, Jun. 24, 2019, Youtube, [https://www.youtube.com/watch?v=\\_SaXjwyVmb8](https://www.youtube.com/watch?v=_SaXjwyVmb8) (Year: 2019).\*

Examiner Prepared, Foreign Registrations and Patents, Various Dates 2018-2022, Questel Orbit, <https://www.orbit.com/export/QPTUJ458/pdf2/cff81f65-d0a1-45e3-8341-f4b2784e60eb-024601.pdf> (Year: 2018).\*

\* cited by examiner

*Primary Examiner* — Brett Miller  
(74) *Attorney, Agent, or Firm* — Georgi Korobanov

(57) **CLAIM**

The ornamental design for a prefab house, as shown and described.

**DESCRIPTION**

FIG. 1 is a rear, right and top perspective view of a prefab house, showing our new design;  
FIG. 2 is front, left and bottom perspective view thereof;  
FIG. 3 is a front view thereof;  
FIG. 4 is a rear view thereof;  
FIG. 5 is a left side view thereof;  
FIG. 6 is a right side view thereof;  
FIG. 7 is a top plan view thereof; and,  
FIG. 8 is a bottom plan view thereof.

**1 Claim, 8 Drawing Sheets**

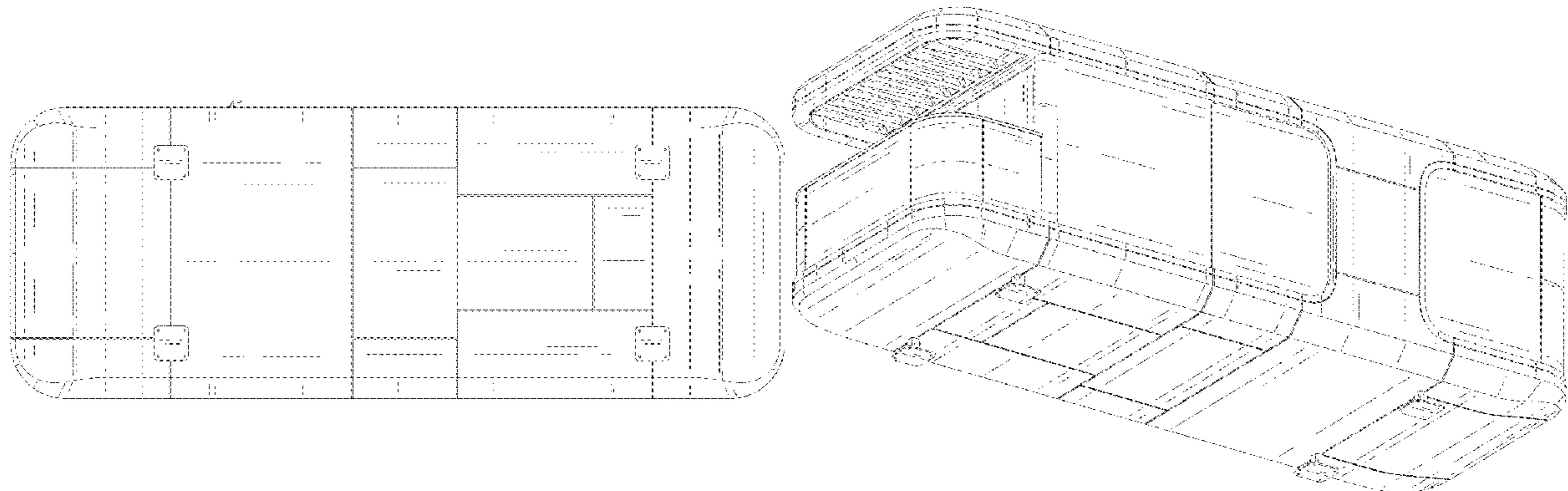

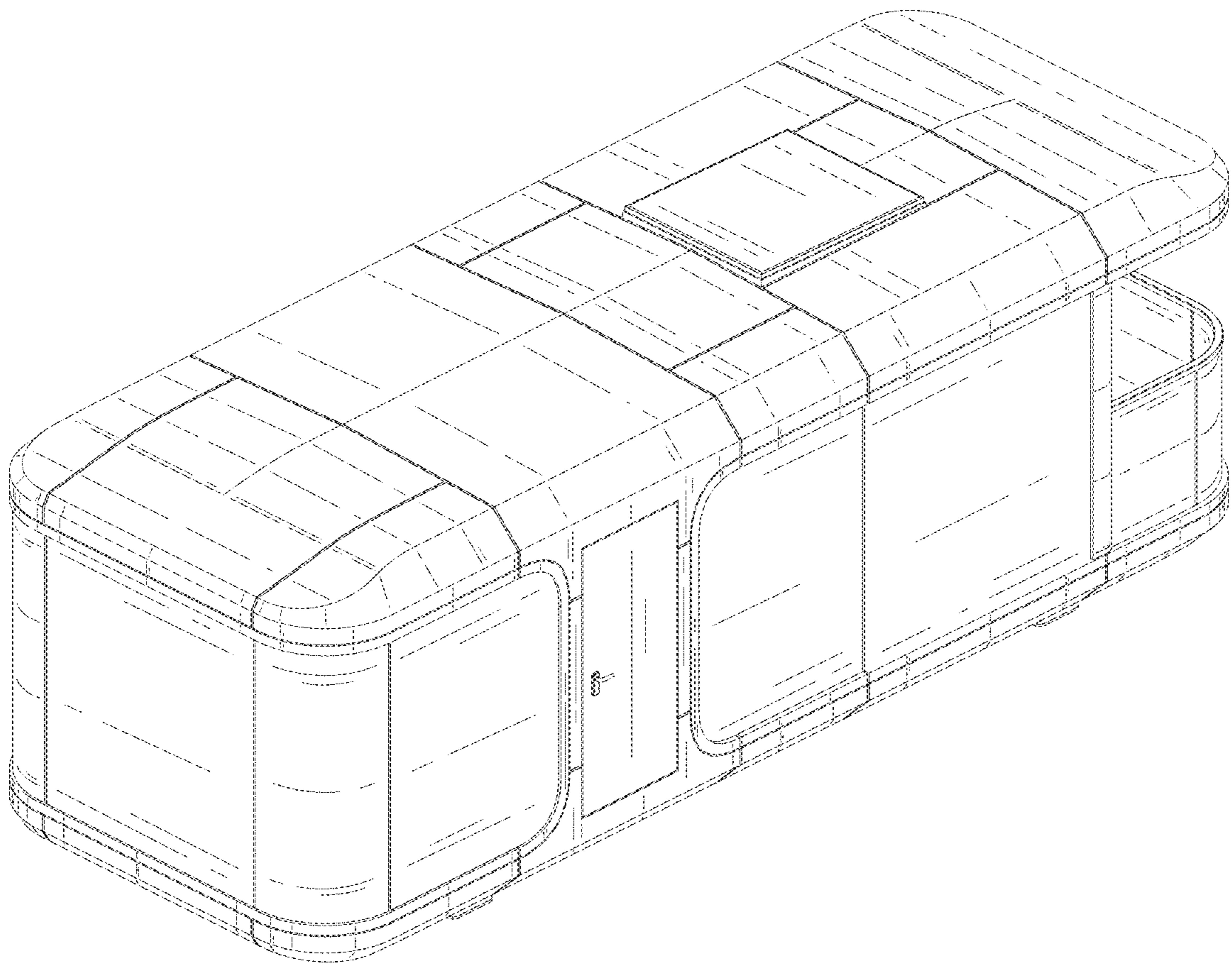

FIG. 1

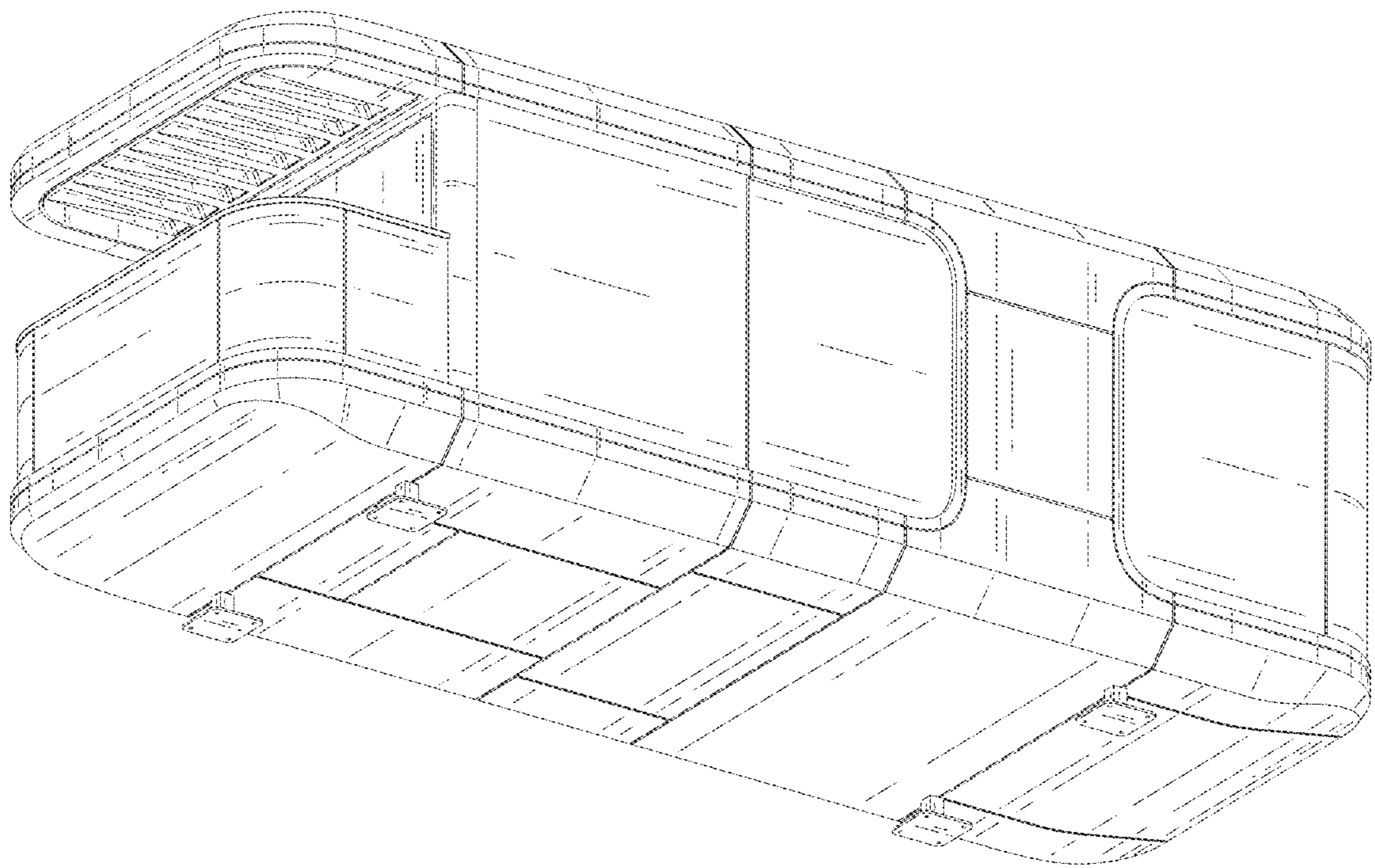

FIG. 2

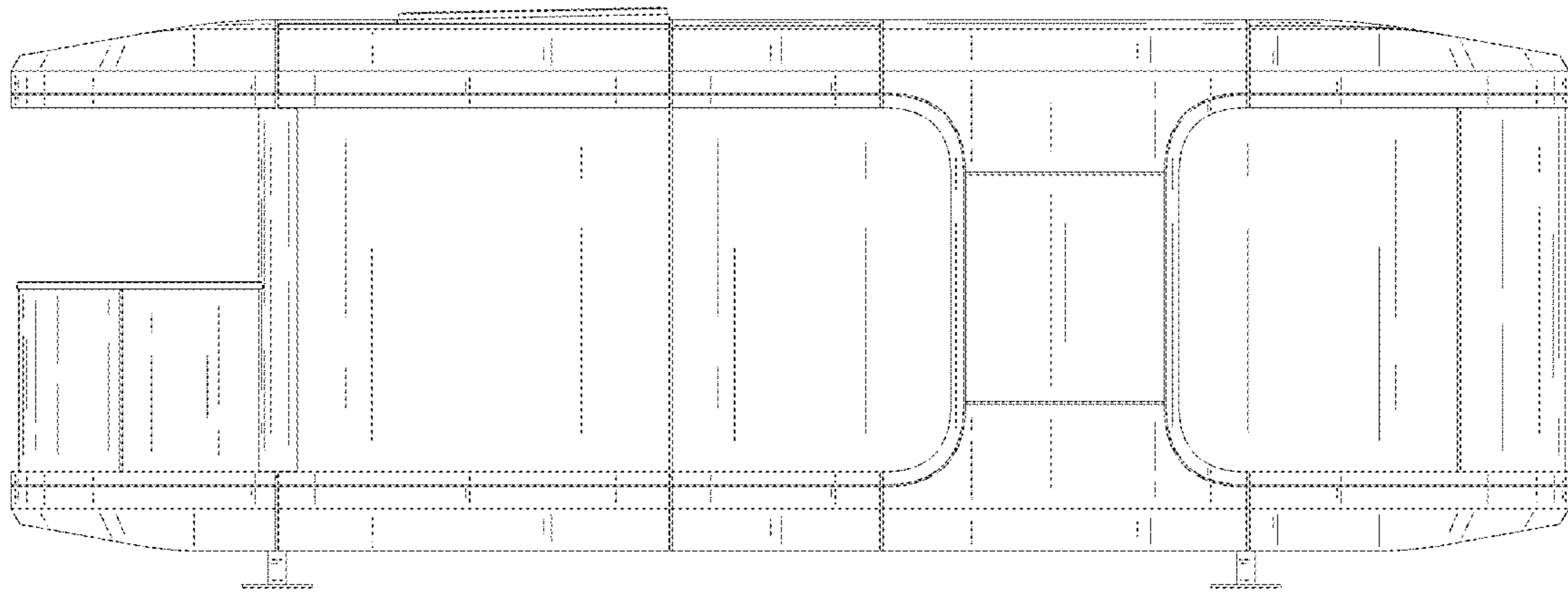

FIG. 3

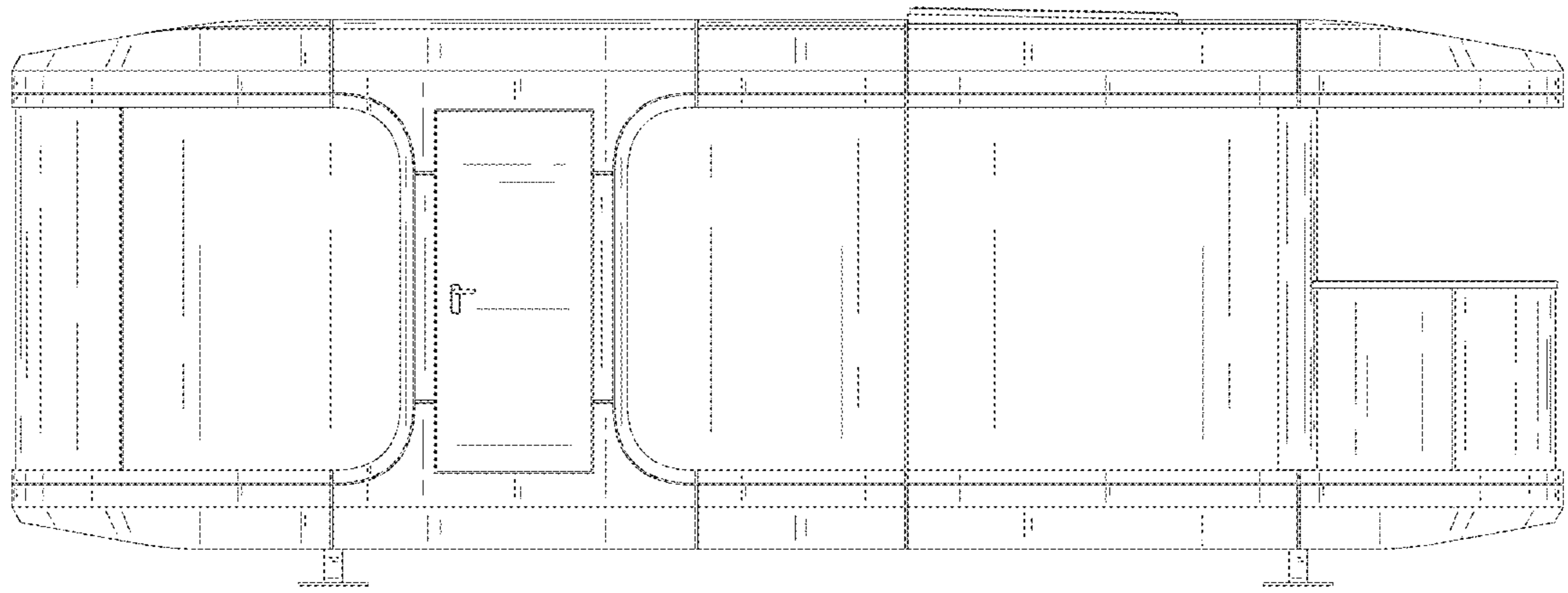

FIG. 4

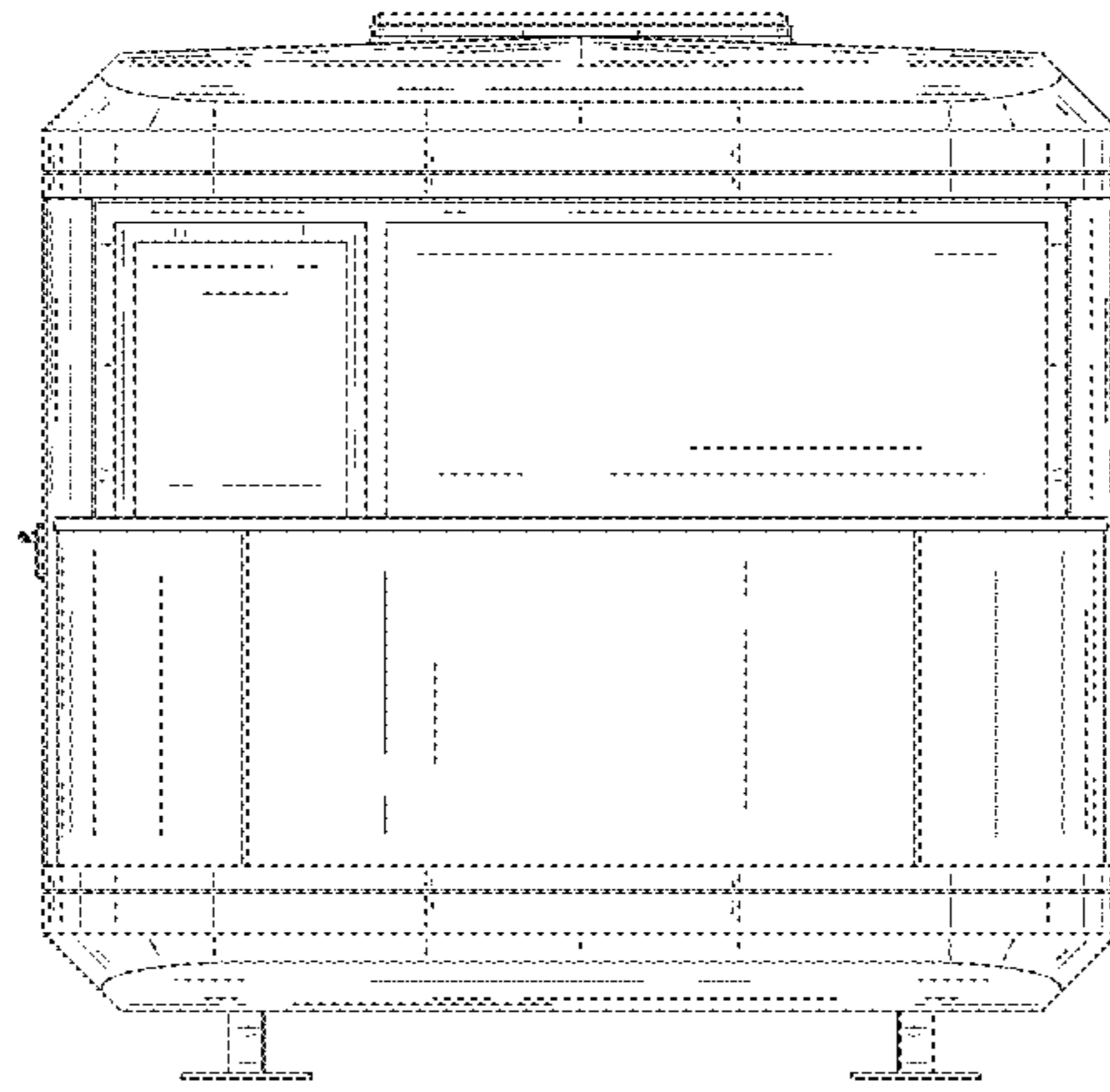

FIG. 5

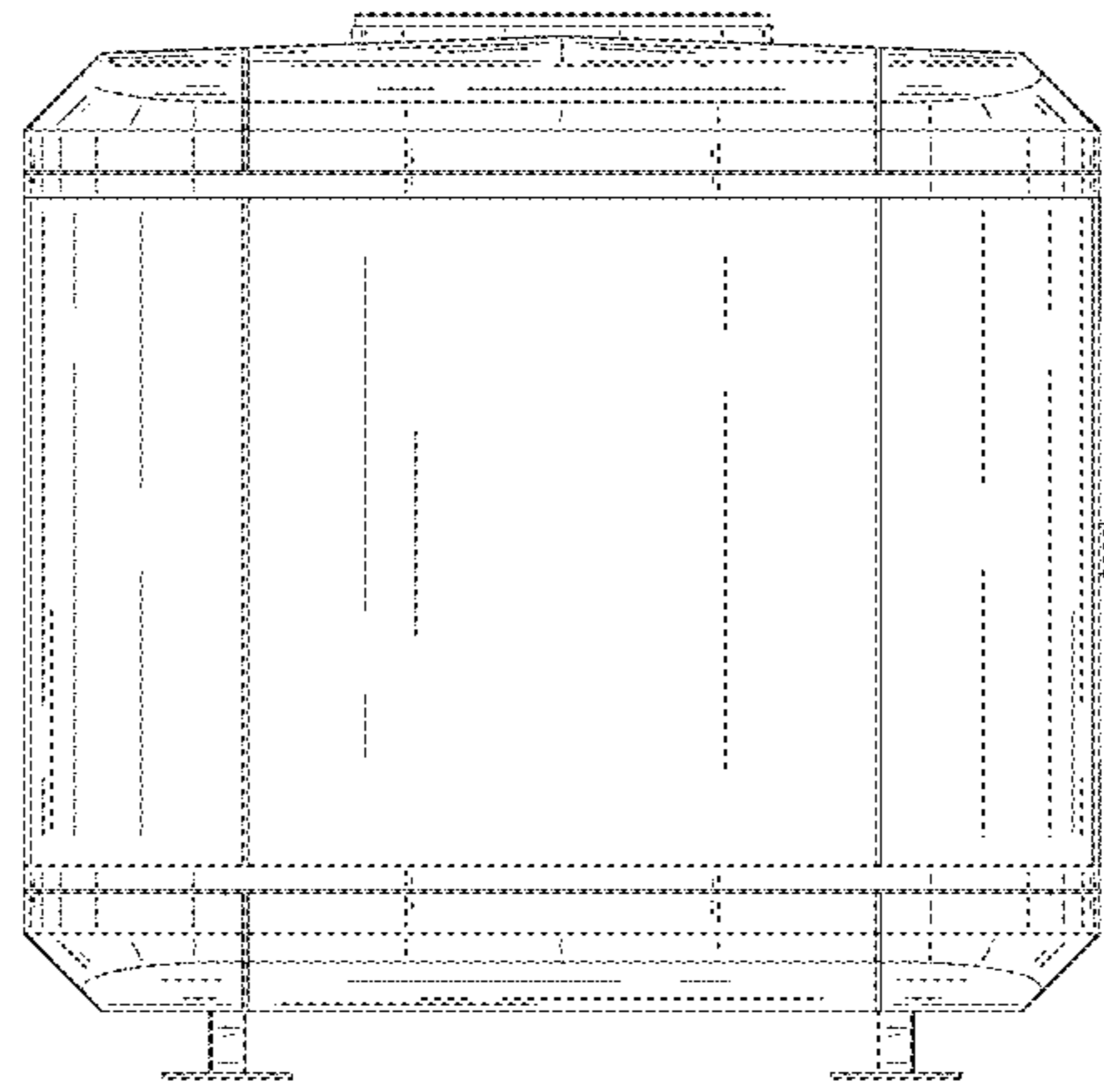

FIG. 6

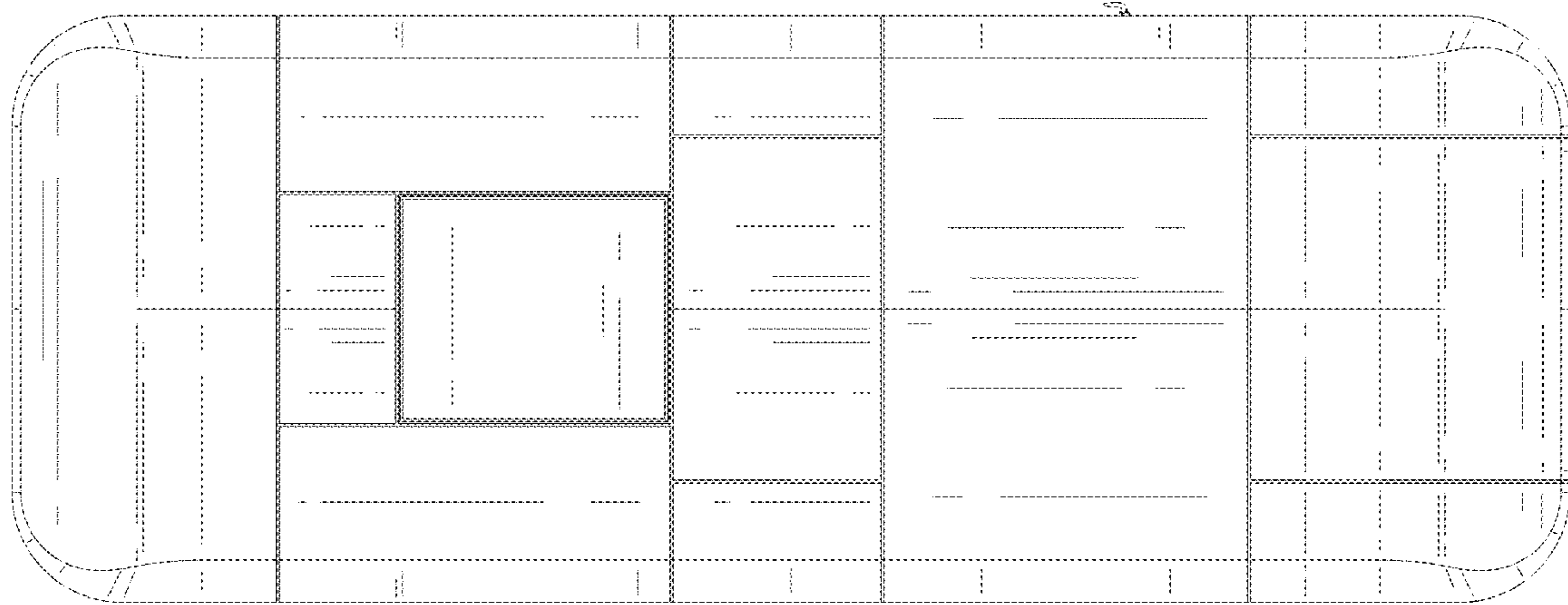

FIG. 7



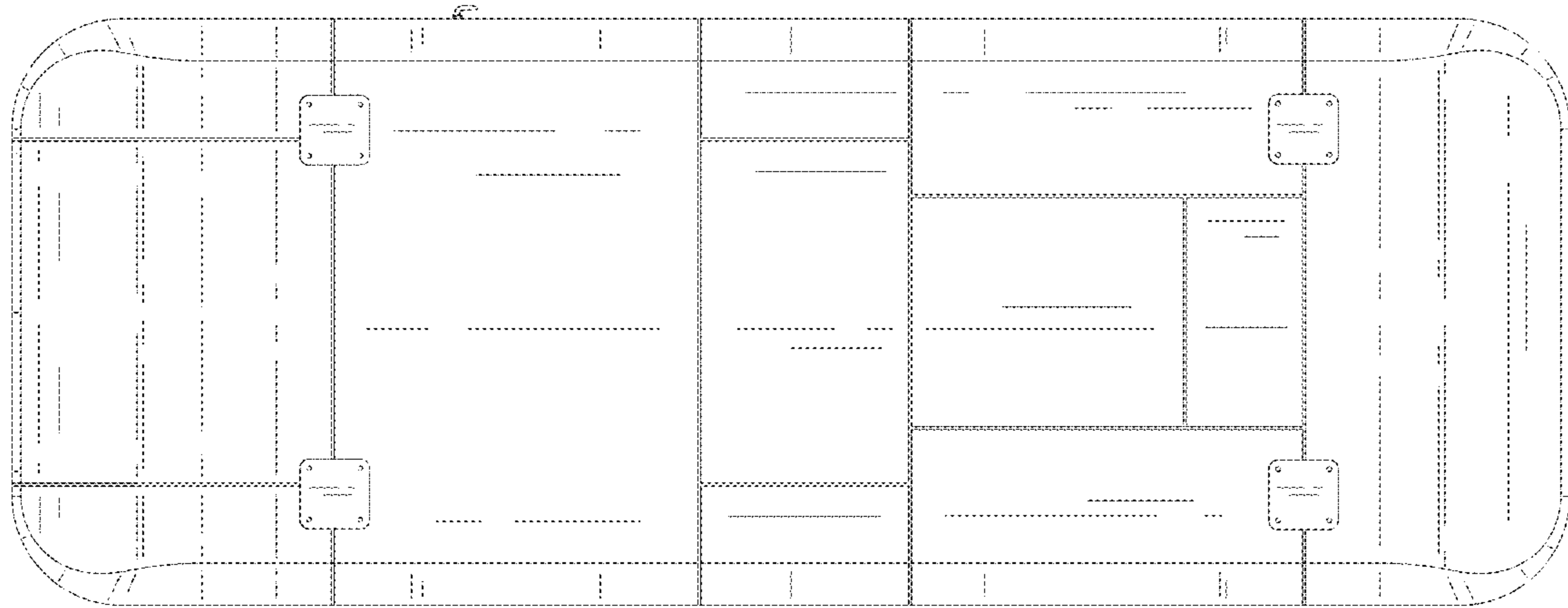

FIG. 8